

**Water Heating and
High Capacity Booster Coils**

Types HI-5 and E-F5

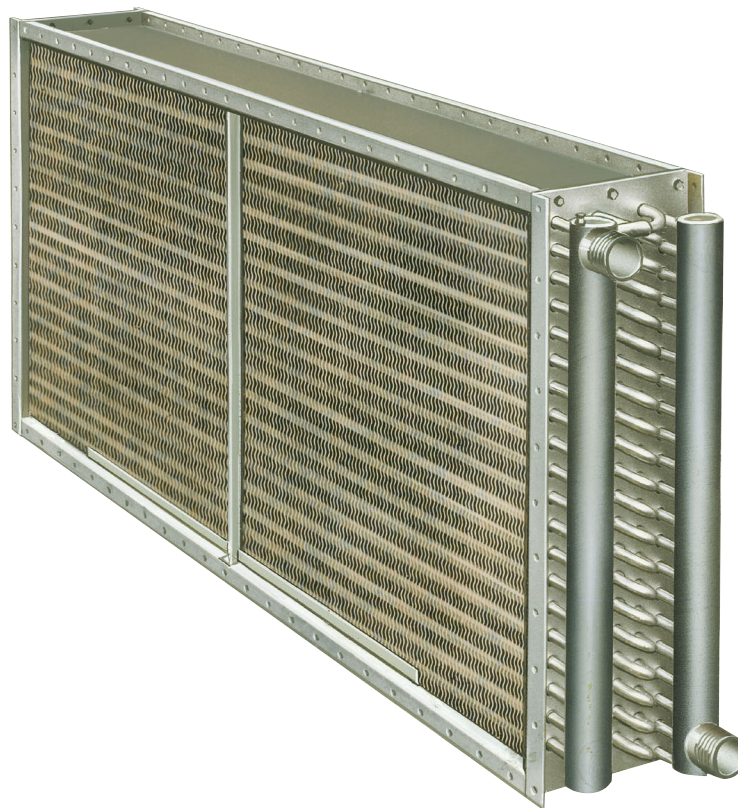

Table of Contents

Introduction	3
Hi-F5 & E-F5 Water Heating and High Capacity Booster Coils	3
A Pioneer in Corrugated Fin Development	4
Design Features	5
General Specifications – 5W and 5B Coils	6
Circuiting Arrangements	7
Flexibility	8
Coil Selection and Application	10
Application Recommendations	10
Conversion of Air Volume to Standard Air	12
General Formulas	13
Capacity Data	14
Heat Transfer Values	14
Air Pressure Drop	18
Water Pressure Drop	20
Dimensional Data	23
Booster Coils	27
Engineering Guide Specifications	30
Water Heating	30
Water Heating Booster Coils	32

©2024 Daikin Applied, Minneapolis, MN. All rights reserved throughout the world. This document contains the most current product information as of this printing. Daikin Applied Americas Inc. has the right to change the information, design, and construction of the product represented within the document without prior notice. For the most up-to-date product information, please go to www.DaikinApplied.com.
™® MicroTech, SiteLine, and Daikin Applied are trademarks or registered trademarks of Daikin Applied Americas Inc. The following are trademarks or registered trademarks of their respective companies: BACnet from American Society of Heating, Refrigerating and Air-Conditioning Engineers, Inc.; Echelon, LonWorks, LonMark, and LonTalk from Echelon Corporation; Modbus from Schneider Electric; and Windows from Microsoft Corporation..

Introduction

Hi-F5 & E-F5 Water Heating and High Capacity Booster Coils

Daikin Applied SelectTools™ for Contractor Coils

Daikin Applied offers a wide variety of standard fin spacings, row and circuiting combinations. For optimum coil selection, Daikin Applied's SelectTools for Contractor Coils selection program makes it easy to select the most economical standard or special application coil to meet your job requirements.

Contact your local Daikin Applied representative for a coil selection that meets the most exacting specification.

AHRI Certification

Daikin Applied water heating and booster coils are certified in accordance with the forced circulation air cooling and air heating coil certification program, which is based on AHRI Standard 410.



NOTE: Special application coils may be outside the scope of AHRI Standard 410.

Nomenclature

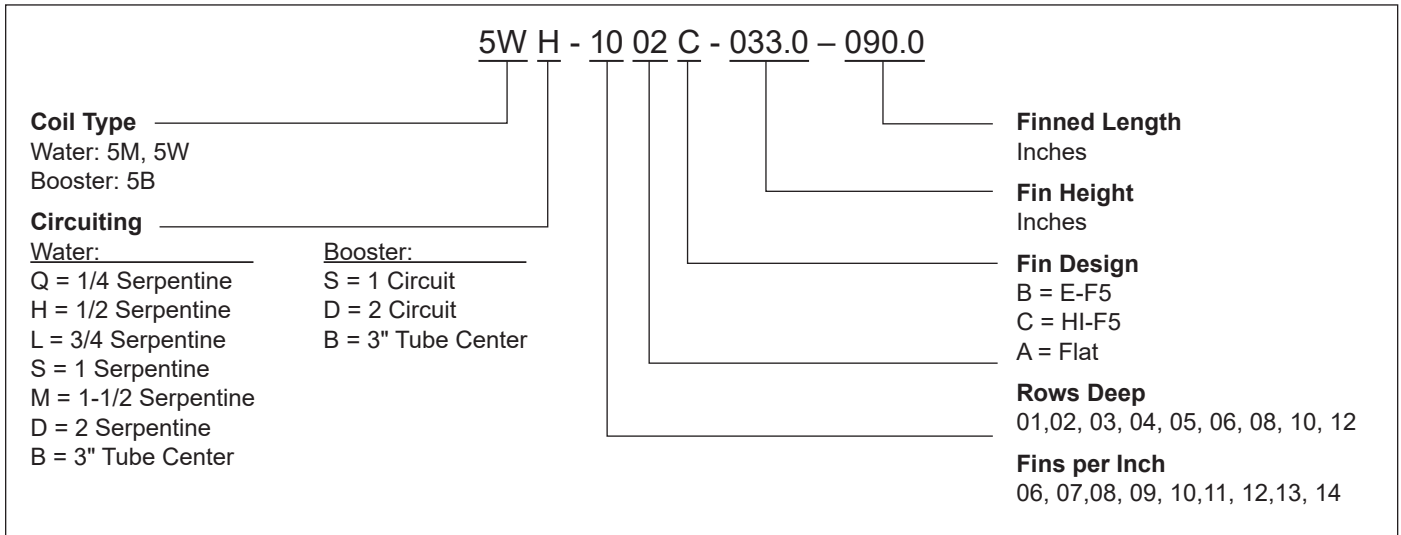

A Pioneer in Corrugated Fin Development

HI-F Means High Efficiency

A principal factor governing fin heat transfer efficiency is the boundary layer film of air adhering to any fin surface. This boundary layer insulates the fin, severely reducing the rate of heat exchange. The advanced rippled-corrugated HI-F design creates a state of continuous turbulence which effectively reduces the boundary layer formation. The exclusive rippled edge instantly deflects the incoming air to create initial turbulence. A succession of corrugations across the fin depth, in conjunction with the staggered tubes, increases the turbulating effect and eliminates the “dead spots” behind the tubes. In this manner, the HI-F design establishes a new high in heat transfer efficiency yielding sharply increased performance. The rippled fin edge also strengthens the fin edge and provides a pleasing overall appearance.

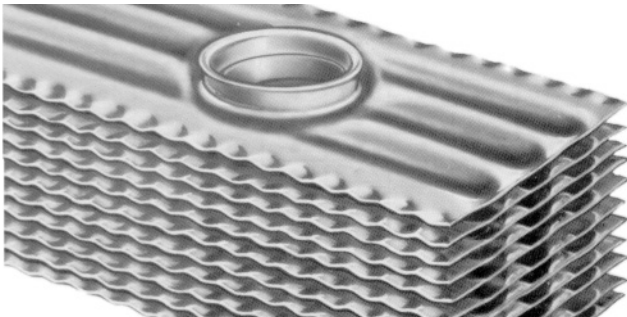

E-F Means Energy Efficient

The term “energy efficient,” which is used to describe how well a system utilizes energy, has become a common expression in the HVAC industry.

With costs of energy rising, the need for cutting operating expenses is apparent. Lowering the air pressure drop across the face of the coil will reduce the fan brake horsepower requirement and fan motor electrical demand. The need to cut operating energy expenses is met by the E-F fin surface. The smoother fin design of the E-F surface results in lower operating costs over the life of the equipment.

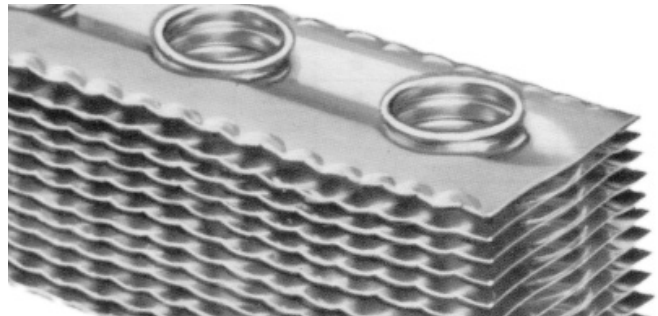

Staggered Tube Design For High Performance

The more moving air in contact with the tubes in the coil, the more performance obtained from the total available surface. The staggered tube design exposes the tubes to more moving air than the in-line design. The geometry of the staggered tube design also allows the rows to be spaced closer together. This results in a more compact coil providing higher capacities.

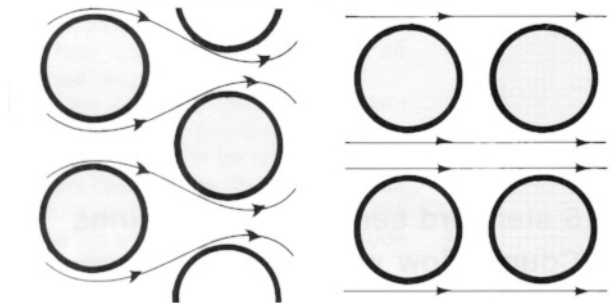

Design Features

A Variety of Fin Spacings

Standard water heating and booster coils are available with 06, 07, 08, 09, 10, 11, 12, 13 or 14 fins per inch. The wide variation in fin spacing permits accurate balancing of coil capacities with the design load.

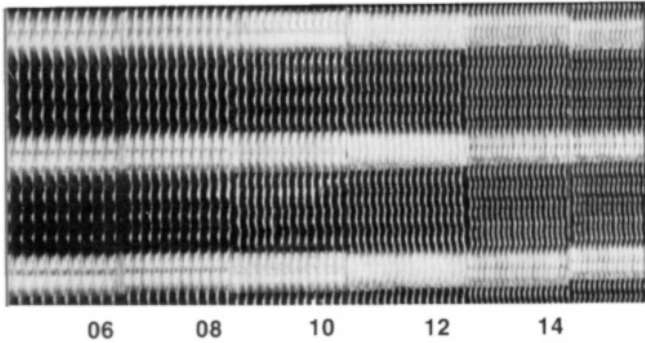

Copper Tube Headers

To provide extended coil life, 5W water heating coils are manufactured from heavy-gauge seamless drawn copper tube. Intruded tube holes provide maximum brazing surface for maximum strength. Copper tubes brazed to copper headers offer a combination of similar materials which eliminates unequal thermal expansion and greatly reduces stress in the tube-header joint.



Full-Fin Collars

Efficient fin presses perform multi-stage operations to draw full fin collars with wide, smooth surfaces that completely cover coil tubes. Our full-fin collars actually form a tube within a tube, yielding greater strength and maximum heat transfer. Lack of sharp collar edges makes our coils easier to clean; smoother fin collars retard lint and dirt accumulations.

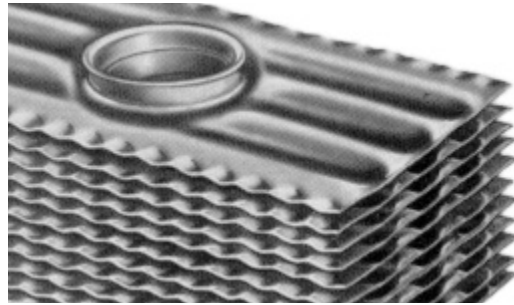

Flanged Casings

Double flanged galvanized steel casings on all water heating coils provide greater strength and better support for easier coil stacking. Moving and handling operations are simplified by the heavy coil casings. Top and bottom casing flanges are turned back to form two channel sections in a "box" shape, providing maximum strength and durability. Hot water booster coils can be furnished with flanges for slip-and-drive fasteners or full flanged casings for standard installations.



General Specifications – 5W and 5B Coils

(1) Primary Surface

Round seamless copper tubes on 1-1/2" or 3" centers. Cupronickel tubes are recommended for high pressure coils and for applications where water conditions tend to be corrosive.

(2) Secondary Surface

Rippled-corrugated aluminum or copper, die-formed plate type fins.

2A. Fin collars are fully drawn to completely cover the tubes for maximum heat transfer and to provide accurate control of fin spacing.

(3) Headers

Extra-heavy, seamless copper tubing. Tube holes are intruded to provide maximum brazing surface for added strength. Header end caps are heavy-gauge, die-formed copper. Cupronickel headers and Monel end caps are available for special applications. Headers are not used on type 5B booster coils.

(4) Connections

Unique hand connections are provided for left-hand or right-hand applications. Universal connections are also available for most coils.

Standard water coil connections:

Steel male pipe supply and return connections. Other materials available on request. (Red brass connections are recommended for coils used with non-ferrous piping.)

Booster coil connections:

Wrought copper, 1/2" NPT, supply and return connections.

(5) Brazing

All joints are brazed with copper brazing alloys.

(6) Casing

Die-formed, heavy-gauge, continuous galvanized steel with reinforced mounting flanges (other materials available on request). Intermediate tube sheets position the core assembly on the larger standard water coils to prevent damage in handling and shipment.

Vents

Furnished on all standard water coils.

Tests

Complete coil tested leak free under warm water containing special wetting agent at 315 psig air pressure.

Operating Conditions

Standard coils are suitable for use up to 250 psig and water temperatures up to 300°F for 5W and 5B, with the exception of hot water coils with a 0.020" nominal tube wall thickness. These coils are suitable for use up to 250 psig and water temperatures up to 200°F, and up to 200 psig at water temperatures between 200°F and 300°F.

Figure 1: 5W and 5B Coil Components

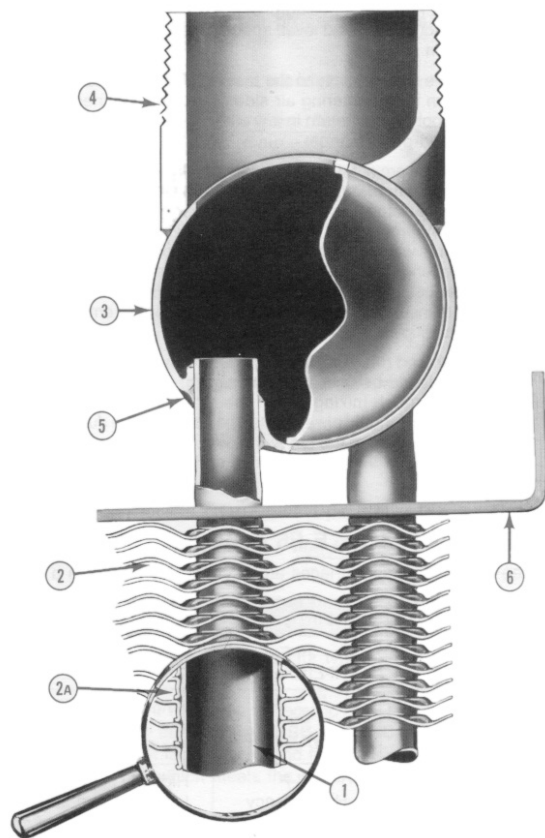

Circuiting Arrangements

Type 5WB, 5WQ, and 5WH coils (Figure 2) are designed to produce high capacity with limited water quantity. High performance is achieved by the increased water velocity obtained from the circuiting of these coil types.

Type 5WL and 5WS coils are designed and engineered to meet most applications requiring normal water quantities and normal water pressure drop.

Type 5WM and 5WD coils are designed specifically for applications that require high water quantities and low water pressure drop.

Type 5BB, 5BS and 5BD (Figure 3) hot water booster coils are designed for use in reheat applications and to produce very high capacities in a limited space. They are particularly suitable for installation in the supply duct to each room for individual room control.

Type 5BB and 5BS coils are single circuited and are available in one and two rows deep.

Type 5BD coils are double circuited and are available in two rows deep.

Figure 2: Hot Water Coil Circuitings

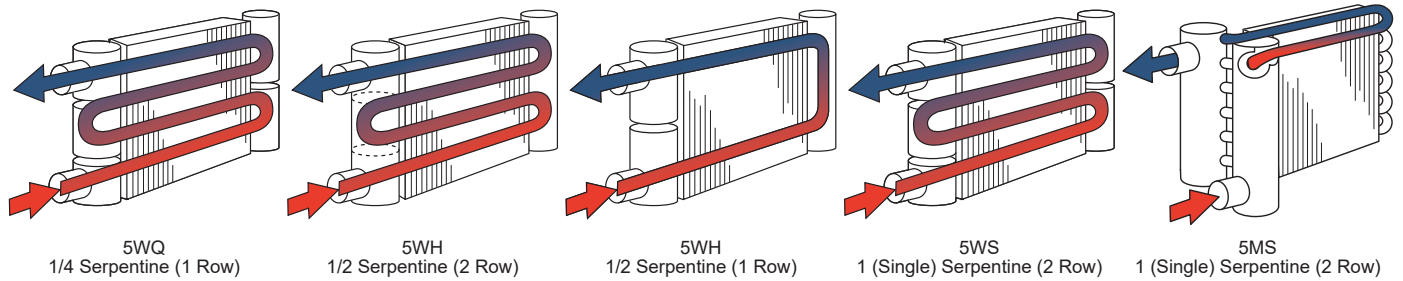
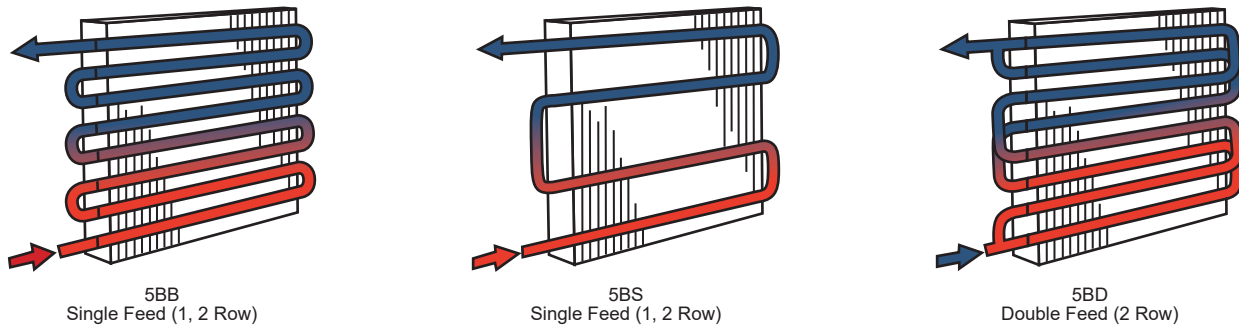

Figure 3: Hot Water (Booster) Coil Circuiting



Flexibility

Along with the standard offerings, optional materials and special configurations are provided to meet many different specifications. Extra long fin lengths, intermediate tube supports, along with a wide variety of tube wall and fin thicknesses are available. Casings can be constructed of galvanized steel, aluminum, stainless steel or copper. Optional connection materials such as steel, Monel, redbrass or copper (sweat) are offered along with butt-weld, victaulic or flange type connections. Coil coatings can be phenolic or Electro Fin.

These are just a few of the options and specials that can be provided. Consult your local Daikin Applied representative for your special coil requirements.

NOTE: Special application coils may be outside the scope of AHRI standard 410.

Table 1: Standard Availability Chart

Coil type		Hot water										Hot water (booster)			
Coil model		5MQ	5MH	5MS	5WB	5WQ	5WH	5WL	5WS	5WM	5WD	5BB	5BS	5BD	
Serpentine circuit		1/4	1/2	1	11 ¹	1/4	1/2	3/4	1	1-1/2	2	1 feed	1 feed	1 feed	
Rows		1	1,2	2	1,2	1-12	1-12	3-12	2-12	4-12	4,6-12	1,2	1,2	2	
Connection location		Same end except 5WS 3-row										Same end			
Fin height 3" increment		12" to 54"			12" to 42" (1 & 2 row) & 12-54 (3-12 row)							6" to 24"			
Fin length 0.10" increment		12" to 216"										6" to 60"			
Fin spacing (FPI)		6 to 14										6 to 14			
Fins	Fin type	HI-F	•	•	•	•	•	•	•	•	•	•	•	•	•
		E-F	•	•	•	•	•	•	•	•	•	•	•	•	•
		Flat	•	•	•	•	•	•	•	•	•	•	•	•	•
	Aluminum	0.0075	•	•	•	•	•	•	•	•	•	•	•	•	•
		0.0095	•	•	•	•	•	•	•	•	•	•	•	•	•
	Copper	0.006	•	•	•	•	•	•	•	•	•	•	•	•	•
		0.0075	•	•	•	•	•	•	•	•	•	•	•	•	•
		0.0095	•	•	•	•	•	•	•	•	•	•	•	•	•
Tubing	Copper	0.020 ¹	•	•	•	•	•	•	•	•	•	•	•	•	•
		0.025	•	•	•	•	•	•	•	•	•	•	•	•	•
		0.035	•	•	•	•	•	•	•	•	•	•	•	•	•
		0.049	•	•	•	•	•	•	•	•	•	•	•	•	•
Tubing diameter		5/8"										5/8"			
Tubing face C/C		1.5		3.0		1.5						3.0	1.5		
Headers standard mat ^{1,2}		Copper tubing										Threaded copper fittings			
Maximum std. operating limits	P	250 psig ³										250 psig ³			
	T	300°F ³										300°F ³			

• Feature available

1. 0.020 is a nominal tube thickness.

2. Optional header materials are available. Consult your local Daikin Applied Sales Representative.

3. Hot water coils with a tube wall thickness of 0.020" have a maximum pressure of 250 psig up to 200°F and 200 psig at temperatures between 200 and 300°F.

Table 2: HI-F5 versus E-F5

Type	Tube Diameter	Fin Type	Application
HI-F5	5/8"	HI-F Hi-Efficiency	Provides highest heat transfer rate for a given amount of surface.
E-F5	5/8"	E-F Energy Efficient	Smoother fin corrugation than the HI-F5 results in a lower air pressure drop and lower fan BHP requirements. The cost of additional surface can be amortized by the KW savings.

Table 3: Standard Water Coil Circulating (Number of Tubes Fed)

Type	Rows	FH Dimensions (Inches)																
		6	9	12	15	18	21	24	27	30	33	36	39	42	45	48	51	54
5BB, 5BS	1, 2	1	1	1	1	1	1	1	—	—	—	—	—	—	—	—	—	—
5BD	2	2	2	2	2	2	2	2	—	—	—	—	—	—	—	—	—	—
5MS	2	—	—	—	—	—	—	—	—	—	—	—	—	—	30	32	34	36
5MH	1, 2	—	—	4	5	6	7	8	9	10	11	12	13	14	15	16	17	18
5MQ	1	—	—	2	—	3	—	4	—	5	—	6	—	7	—	8	—	9
5WB, 5WQ	1	—	—	2	2.5	3	3.5	4	4.5	5	5.5	6	6.5	7	—	—	—	—
5WH	1, 2, 3, 4	—	—	4	5	6	7	8	9	10	11	12	13	14	15*	16*	17*	18*
5WB	2	—	—	4	4	6	7	8	9	10	11	12	13	14	—	—	—	—
5WL	3, 4	—	—	6	7	9	10	12	13	15	16	18	19	21	22	24	25	27
5WS	2	—	—	8	10	12	14	16	18	20	22	24	26	28	—	—	—	—
5WS	3, 4	—	—	8	10	12	14	16	18	20	22	24	26	28	30	32	34	36
5WM	4	—	—	12	15	18	21	24	27	30	33	36	39	42	45	48	51	54
5WD	4	—	—	16	20	24	28	32	36	40	44	48	52	56	60	64	68	72

* 3 & 4 row coil only. See 5MH for 1 & 2 rows.

Table 4: Coil Sizes (Face Area on sq. ft.)

Finned Height – FH (Inches)	Finned Length – FL (Inches)																									
	12	15	18	21	24	30	36	42	48	54	60	66	72	78	84	90	96	102	108	114	120	126	132	138	141	
*6	0.5	0.6	0.8	0.9	1.0	1.3	1.5	1.8	2.0	2.2	2.5	—	—	—	—	—	—	—	—	—	—	—	—	—	—	—
*9	0.8	0.9	1.1	1.3	4.5	1.9	2.3	2.6	3.0	3.4	3.7	—	—	—	—	—	—	—	—	—	—	—	—	—	—	—
12	1.0	1.3	1.5	1.8	2.0	2.5	3.0	3.5	4.0	4.5	5.0	5.5	6.0	6.5	7.0	7.5	8.0	8.5	9.0	9.5	10.0	—	—	—	—	—
15	—	1.6	1.9	2.19	2.5	3.1	3.8	4.9	5.0	5.6	6.2	6.9	7.5	8.1	8.7	9.4	10.0	10.6	11.2	11.9	12.5	—	—	—	—	—
18	—	—	2.3	2.62	3.0	3.8	4.5	5.3	6.0	6.7	7.5	8.2	9.0	9.7	10.5	11.2	12.0	12.7	13.5	14.2	15.0	—	—	—	—	—
21	—	—	—	3.06	3.5	4.4	5.3	6.1	7.0	7.9	8.7	9.6	10.5	11.4	12.2	13.1	14.0	14.9	15.7	16.6	17.5	—	—	—	—	—
24	—	—	—	—	40.0	5.0	6.0	7.0	8.0	9.0	10.0	11.0	12.0	13.0	14.0	15.0	16.0	17.0	18.0	19.0	20.0	—	—	—	—	—
27	—	—	—	—	—	5.6	6.8	7.9	9.0	10.1	11.2	12.4	13.5	14.6	15.7	16.9	18.0	19.1	20.2	21.4	22.5	—	—	—	—	—
30	—	—	—	—	—	6.3	7.5	8.8	10.0	11.2	12.5	13.7	15.0	16.2	17.5	18.7	20.0	21.2	22.5	23.7	25.0	—	—	—	—	—
33	—	—	—	—	—	—	8.3	9.6	11.0	12.4	13.7	15.1	16.5	17.9	19.2	20.6	22.0	23.4	24.7	26.1	27.5	—	—	—	—	—
36	—	—	—	—	—	—	9.0	10.5	12.0	13.5	15.0	16.5	18.0	19.5	21.0	22.5	24.0	25.5	27.0	28.5	30.0	—	—	—	—	—
39	—	—	—	—	—	—	—	11.4	13.0	14.6	16.2	17.9	19.5	21.0	22.7	24.4	26.0	27.6	29.2	30.9	32.5	—	—	—	—	—
42	—	—	—	—	—	—	—	12.3	14.0	15.7	17.5	19.2	21.0	22.7	24.5	26.2	28.0	29.7	31.5	33.2	35.0	—	—	—	—	—
45	—	—	—	—	—	—	—	—	15.0	16.9	18.8	20.6	22.5	24.4	26.3	28.1	30.0	31.9	33.8	35.7	37.5	39.4	41.3	43.1	44.1	44.1
48	—	—	—	—	—	—	—	—	16.0	18.0	20.0	22.0	24.0	26.0	28.0	30.0	32.0	34.0	36.0	38.0	40.0	42.0	44.0	46.0	47.0	47.0
51	—	—	—	—	—	—	—	—	—	19.1	21.3	23.4	25.5	27.6	29.8	31.9	34.0	36.1	38.3	40.4	42.5	44.6	46.8	48.9	49.9	49.9
54	—	—	—	—	—	—	—	—	—	20.3	22.5	24.8	27.0	29.3	31.5	33.8	36.0	38.3	40.5	42.8	45.0	47.3	49.5	51.8	52.9	52.9

In addition to the standard fin lengths listed above, any required length can be supplied. * Standard on Type 5B coils. Booster coil sizes in shaded areas.

Coil Selection and Application

Application Recommendations

1. Piping should be in accordance with accepted industry standards.
2. When drainable coils are desired, tubes should be installed in a horizontal position. Use a spirit level. If the tubes cannot be installed level, special drain headers are available on request.
3. Connect the water supply to the leaving air side and the water return to the entering air side of the coil. Connecting the supply and/or return in any other manner will result in a reduced performance.
4. Hot water coils are not normally recommended for use with entering air temperatures below 40°F; however, special high pressure water coils have been used very successfully on high temperature hot water jobs with low entering air temperatures when correctly controlled. No control system can be depended on to be 100% safe against freeze-up with water coils. Glycol solutions or brines are the only freeze-safe media for operation of water coils for low entering air conditions.
5. When fresh and return air are to be heated by a hot water coil, care should be used in the design of the ductwork to provide thorough mixing before the air enters the coil. The return air should always enter the bottom of the duct. Fresh air should enter the top of the duct. The greater the distance between the point of mixing and entrance to the coil, the better the application.

Temperature control elements should be located to sense the lowest temperature air that will enter the coil.

Always install gasketed fresh air dampers which are automatically controlled to close whenever the water leaving the coil is too cool, or the fan stops. Care should be used in designing fresh air intakes to prevent stack effect (or wind) from forcing cold air through the coils when the fan is shut down. Two sets of dampers are frequently required. Continuous water circulation through the coils at all times is recommended when fresh air mixtures are used.

Face and bypass dampers are recommended in preference to valves for controlling leaving air temperature from hot water coils used to heat fresh air mixtures.
6. Two-position or modulating valves can be used to control hot water coils on booster applications. Follow standard recommendations of the control manufacturer regarding sizing of valves and location of temperature controllers for these applications.
7. Pipe sizes for the system must be selected on the basis of the head (pressure) available from the circulating pump. It is recommended that the velocity should not generally exceed 8 feet per second and that the pressure drop should be approximately 3 feet of water per 100 feet of pipe.

Sample Coil Selection

Given:

SCFM (see page 10 for standard air)	6,000
Required BTUH	240,000
Entering air temperature	45°F
Entering water temperature	200°F
Gallons per minute	16.0 GPM
Coil face	24" × 72"
Maximum pressure drop	5.0 ft. H ₂ O

Solution:

- Determine coil face area:

$$\frac{24 \times 72}{144} = 12.0 \text{ sq. ft.}$$

- Determine coil face velocity:

$$\frac{\text{SCFM}}{\text{Face Area}} = \frac{6,000}{12.0} = 500 \text{ FPM}$$

- Determine air temperature rise:

$$\frac{\text{BTUH}}{1.09 \times \text{SCFM}} = \frac{240,000}{1.09 \times 6,000} = 36.7^\circ\text{F}$$

- Determine water temperature drop:

$$\frac{\text{BTUH}}{500 \times \text{GPM}} = \frac{240,000}{500 \times 16.0} = 30^\circ\text{F}$$

- Determine approximate number of feeds required:

Assume 4-GPM/feed for calculation purposes.

$$\text{No. of Feeds} = \frac{\text{GPM}}{\text{GPM/feed}} = \frac{16.0}{4} = 4$$

See Table 2, page 10, under 24 FH dimension to determine which coil type is available for the number of feeds desired (or closest to desired). Type 5WB and 5WQ 1-row coils have four feeds. Check type 5WB first because this is the most economical coil.

- Determine water pressure drop: Follow the example on page 18. Read the header side and tube side pressure drop. In this example the header side pressure drop = 1.4 ft. H₂O and the tube side pressure drop = 2.2 ft. H₂O. These pressure drops must be adjusted by using the temperature correction factors. At 185°F average water temperature this results in the following pressure drops: tube = 1.2 × 2.2 = 2.64; header = 1.48 × 1.2 = 1.77. Therefore, the total pressure drop = 2.64 + 1.77 = 4.42 ft. H₂O.

- Assuming a 1-row type 5WB coil will meet the requirements, the proper fin series must be determined as follows:

- Determine heat transfer value: M_t

$$\text{a. } \frac{\text{Air Temp. Rise}}{\text{Ent. Water Temp.} - \text{Ent. Air Temp.}} = \frac{36.7}{200 - 45} = 0.237$$

$$\text{b. } \frac{\text{Water Temp. Drop}}{\text{Air Temp. Rise}} = \frac{30}{36.7} = 0.818$$

With values from steps a. and b. above, proceed to Figure 3, page 11, and find $M_t = 0.33$

- Determine heat transfer value: R_{ft}

$$\text{Rows Deep} = R_{ft} \times M_t \times \frac{\text{FPM}}{100}$$

Since we have assumed a 1-row coil:

$$\text{Max. } R_{ft} = \frac{1}{M_t \times \frac{\text{FPM}}{100}} = \frac{1}{0.33 \times \frac{500}{100}} = \frac{1}{1.65} = 0.606$$

Proceed to the Figure 5, page 13, with 4 GPM/feed and:

$$\begin{aligned} \text{Avg. H}_2\text{O Temp.} &= \frac{\text{Ent. H}_2\text{O Temp.} + \text{Lvg. H}_2\text{O Temp.}}{2} \\ &= \frac{200 + 170}{2} = 185^\circ\text{F} \end{aligned}$$

and find $R_{f1} = 0.183$ for type 5WB coils.

R_{f2} must equal $R_{ft} - R_{f1} = (0.606 - 0.183) = 0.423$ or less for a 1-row type 5WB coil to meet the requirements. Enter R_{f2} curve for type 5BB and 5WB coils, page 14 at 500 FPM face velocity and find that $R_{f2} = 0.42$ fin series 12, which meets the requirements.

- Final coil selection:

The final selection is a 5WB-1201C-24 × 72 coil.

- Determine air pressure drop:

Follow the example on page 15. With 500 FPM, 12 fin series and a 1-row coil, the air pressure drop is 0.19 inches of water.

Conversion of Air Volume to Standard Air

Figure 4: Temperature Conversion Factor

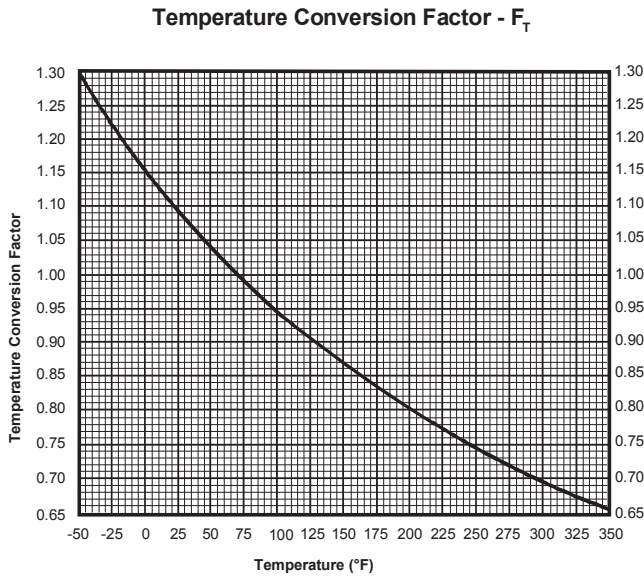
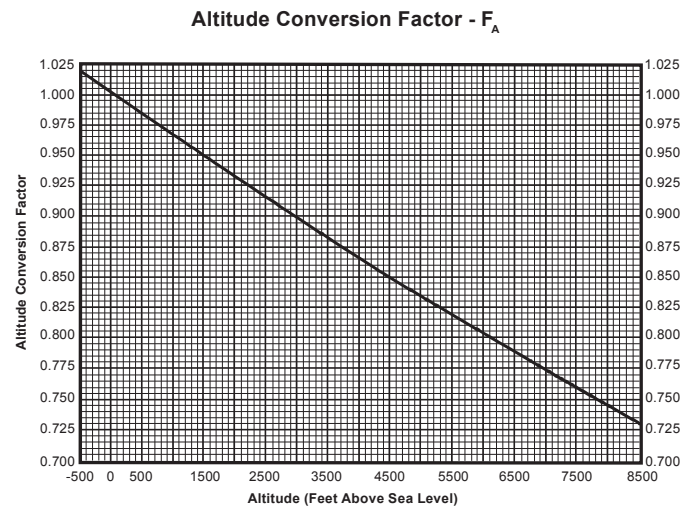

Figure 5: Altitude Conversion Factor



When the specified air volume (CFM) is given at any temperature other than 70° F or any altitude other than sea level, these charts should be used for correction before using the capacity and pressure drop tables which are based on CFM at standard air conditions.

Example:

To convert 15,900 CFM of air at 95°F and at 3,000 feet altitude to standard conditions:

$$\begin{aligned}
 \text{CFM of Standard Air} &= \text{CFM of Specified Air} \times F_T \times F_A \\
 &= 15,900 \times 0.955 \times 0.896 \\
 &= 13.6
 \end{aligned}$$

Where:

- F_T = Temperature Conversion Factor
- F_A = Altitude Conversion Factor

The CFM of standard air should be used to determine face velocity through the coil, which in turn is used to determine heat transfer values, and the air pressure drop through the coil.

The air pressure drop value taken from Figures 4 and 5 must be converted to altitude to be used for static pressure calculations. To convert the air pressure drop from standard air at sea level to the air pressure drop at altitude use the following equation:

$$\text{Pressure Drop at Altitude} = \frac{\text{Pressure Drop at Sea Level}}{F_T \times F_A}$$

General Formulas

Total BTUH — Air Side:

$$\text{Total BTUH} = 1.09 \times \text{SCFM} \times (\text{Lvg. Air Dry Bulb} - \text{Ent. Air Dry Bulb})$$

Where:

$$1.09 = (\text{Sp. Ht. of Air at } 70^\circ\text{F}) \times (\text{min./hr.}) \times \text{Density Std. Air}$$

$$0.242 = \text{Sp. Ht. of Moist Air at } 70^\circ\text{F}$$

$$60 = \text{min./hr.}$$

$$0.075 = \text{Density Std. Air in Lbs./Cu.Ft.}$$

Total BTUH — Water Side:

$$\text{Total BTUH} = 500 \times \text{GPM} \times (\text{Ent. Water Temp.} - \text{Lvg. Water Temp.})$$

Where:

$$500 = \text{lbs./gal.} \times \text{min./hr.} \times \text{specific heat water}$$

$$8.33 = \text{lbs./gal.}$$

$$60 = \text{min./hr.}$$

$$1 = \text{specific heat water}$$

Initial Temperature Difference (ITD):

$$\text{ITD} = \text{Ent. Water Temp.} - \text{Ent. Air Dry Bulb}$$

MBH per Square Foot of Face Area:

$$\text{MBH/Sq. Ft.} = \frac{\text{Total BTUH}}{\text{Face Area (Sq. Ft.)} \times 1000}$$

Leaving Air Temperature:

$$\text{Lvg. Air Dry Bulb} = \text{Ent. Air Dry Bulb} + \frac{\text{Total BTUH}}{1.09 \times \text{SCFM}}$$

Water Velocity:

$$5/8" \text{ Tubes: Water Velocity FPS} = \frac{1.07 \times \text{GPM}}{\text{No. of Tubes Fed}}$$

Face Area:

$$\text{FA} = \frac{\text{SCFM}}{\text{Face Velocity (FPM)}}$$

Face Velocity:

$$\text{FV} = \frac{\text{SCFM}}{\text{Face Area (Sq. Ft.)}}$$

ROWS DEEP:

$$\text{Rows Deep} = \frac{R_r \times M_r \times \text{Face Velocity (FPM)}}{100}$$

Capacity Data

Heat Transfer Values

Figure 6: Heat Transfer Values (M_t) – 1- and 2-Row Coils

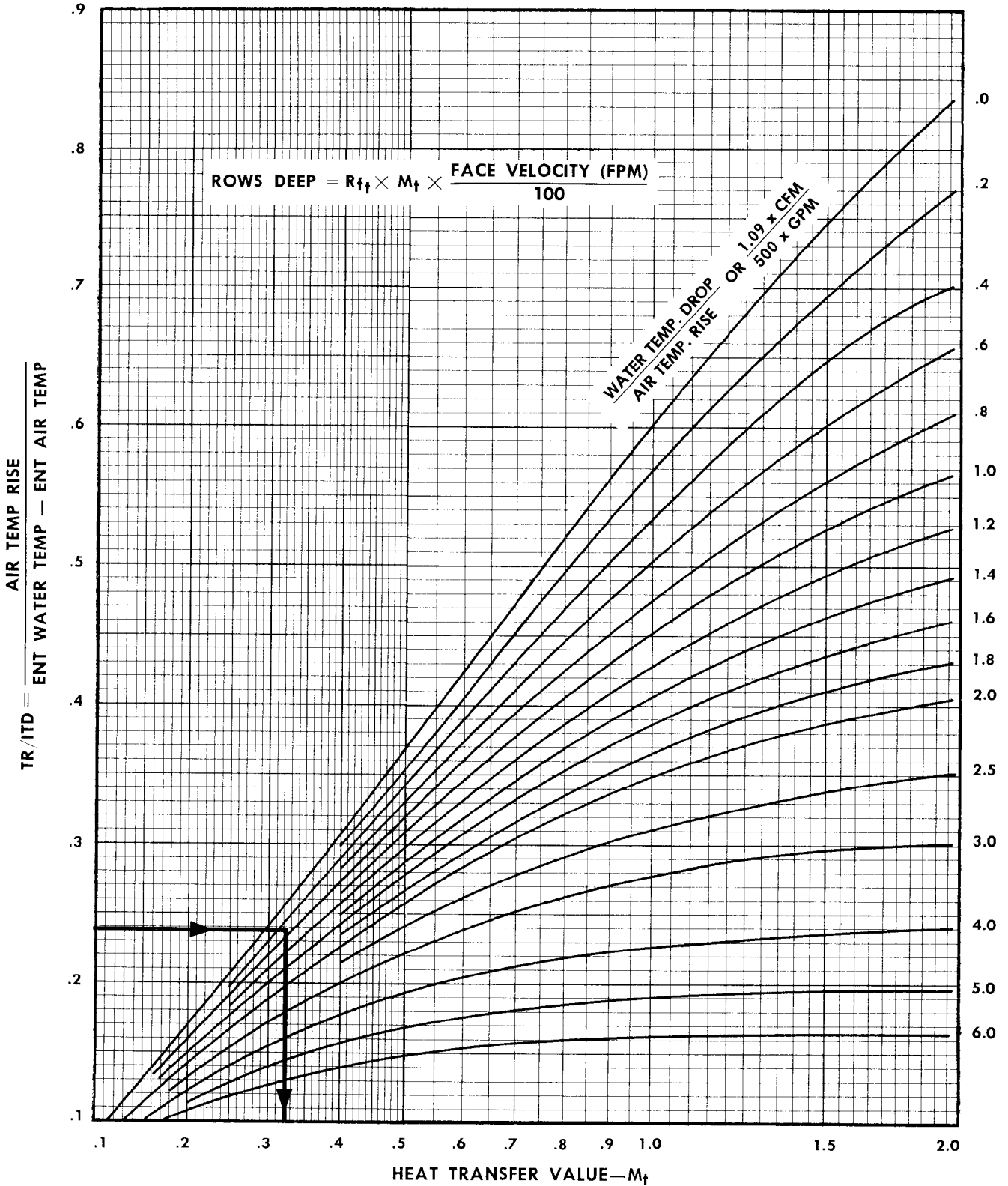

Figure 7: Heat Transfer Values (M_t) – 3- and 4-Row Coils

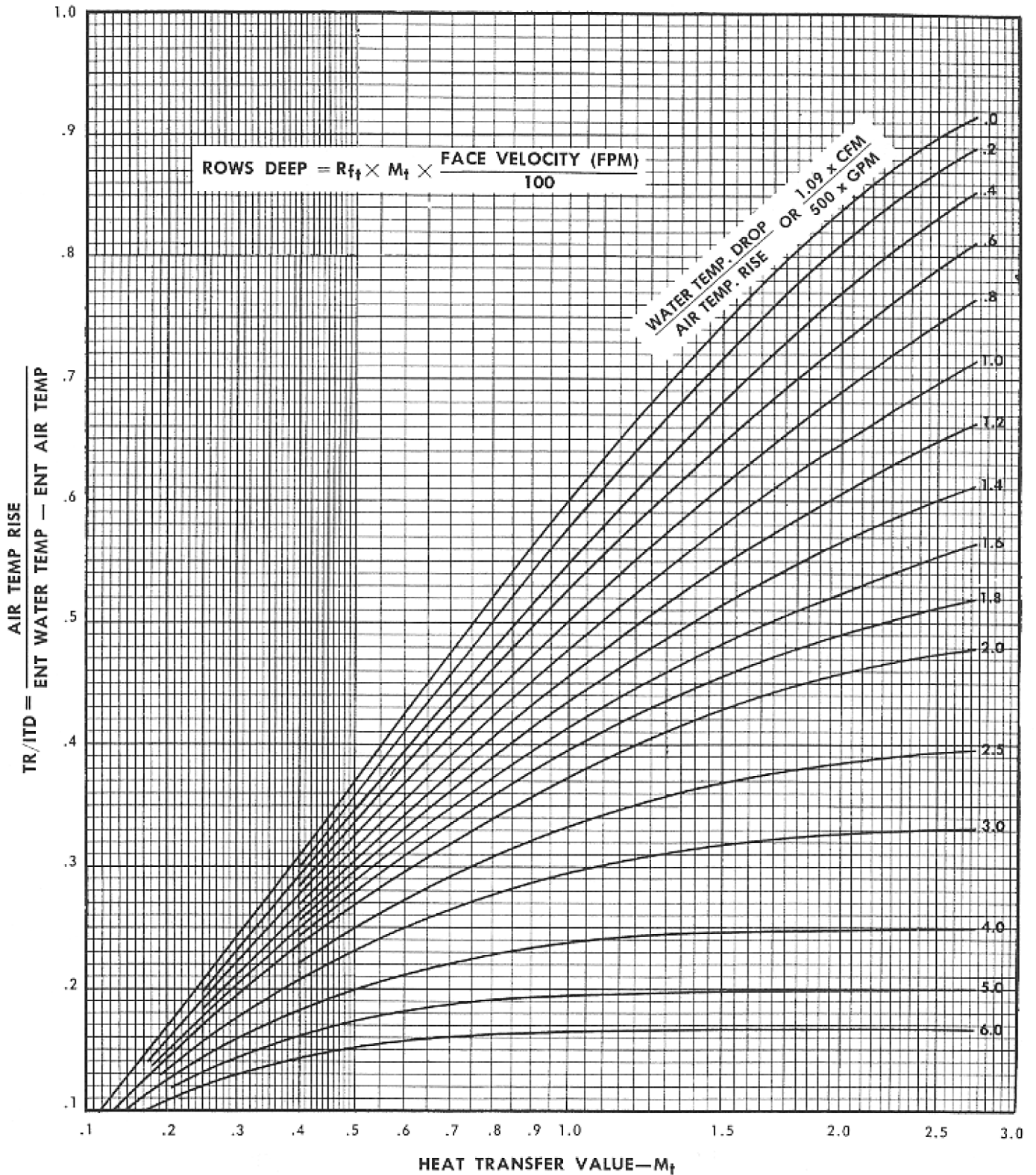
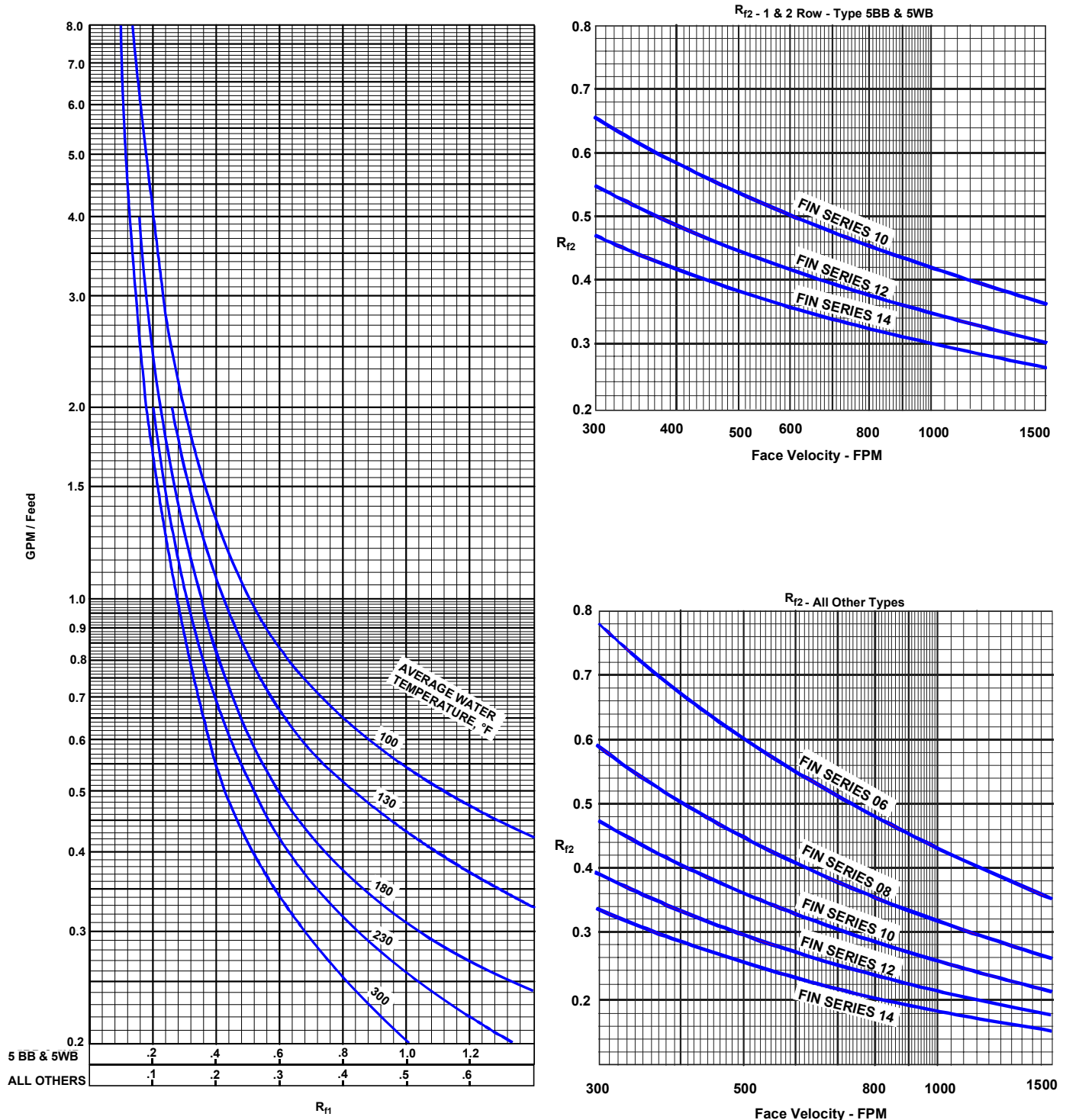
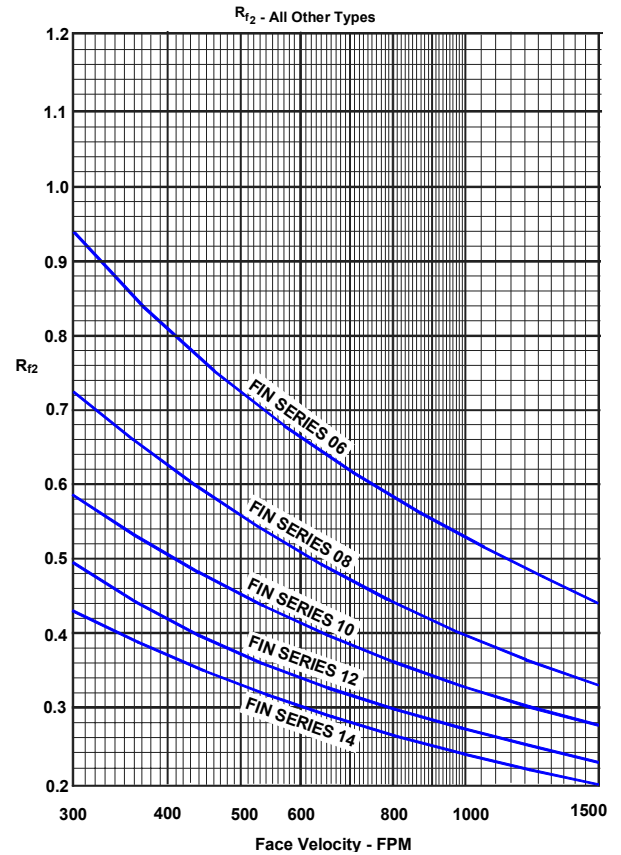
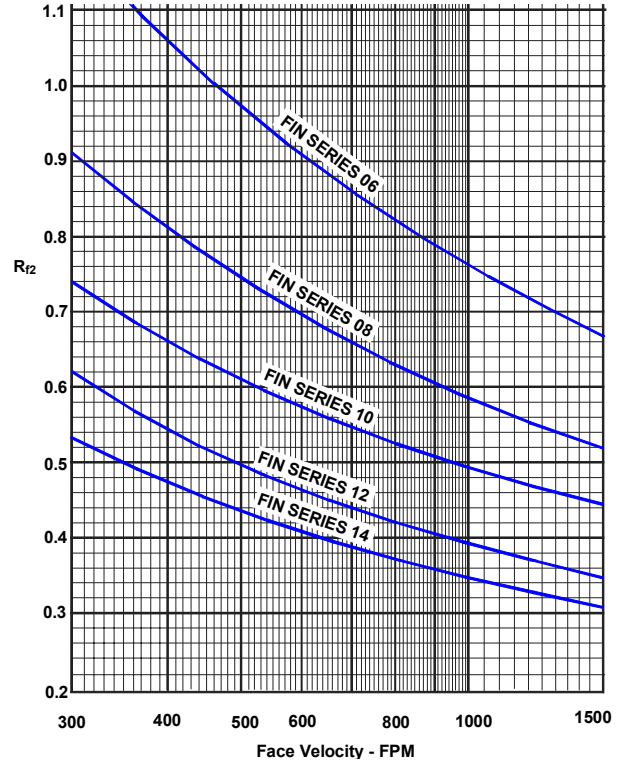
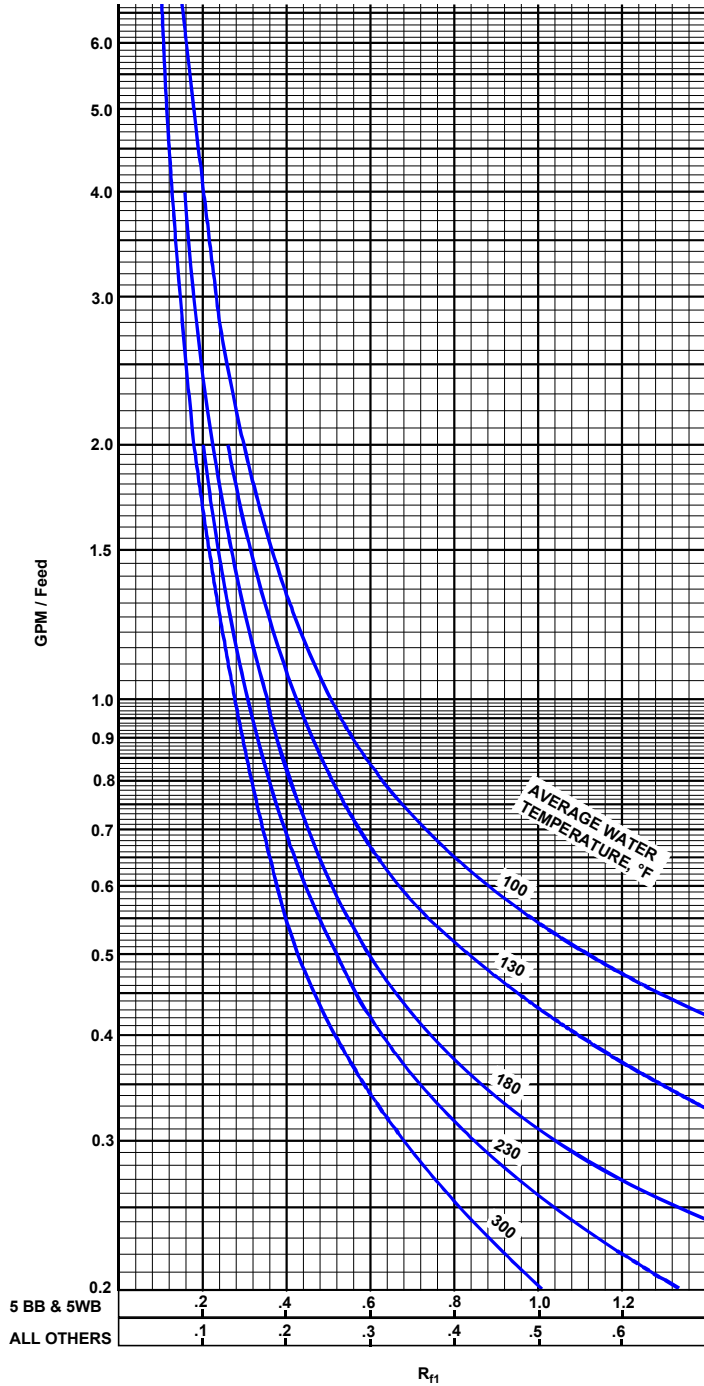

Figure 8: Heat Transfer Values (R_f) – HI-F5 Coils



NOTE: Heat transfer values for odd fin spacings may be found by interpolation.

Figure 9: Heat Transfer Values (R_1) – E-F5 Coils



NOTE: Heat transfer values for odd fin spacings may be found by interpolation.

Air Pressure Drop

Figure 10: Air Pressure Drop – HI-F5 Coils

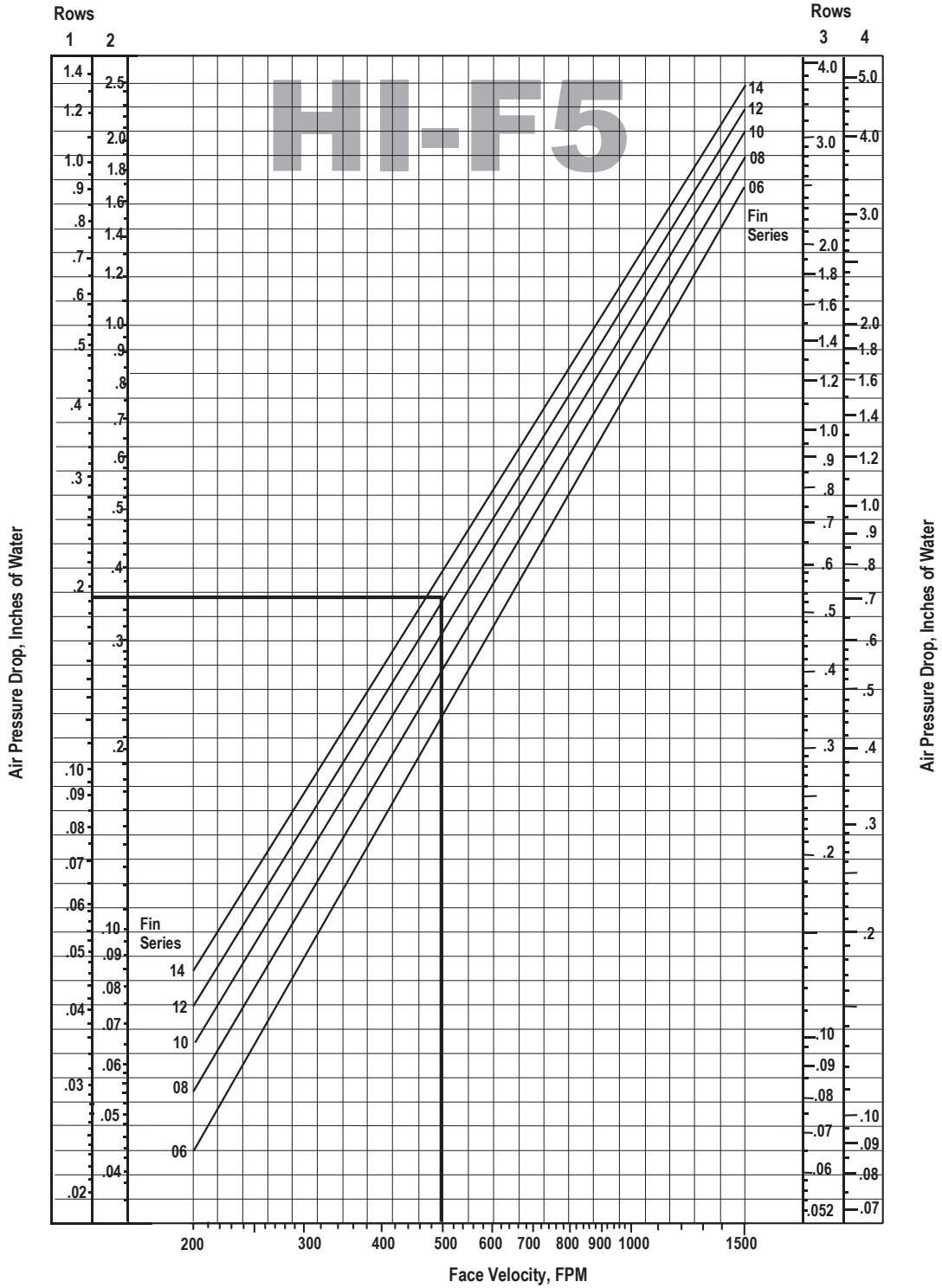

NOTE: Air pressure drop values for odd fin spacing.

Figure 11: Air Pressure Drop – E-F5 Coils

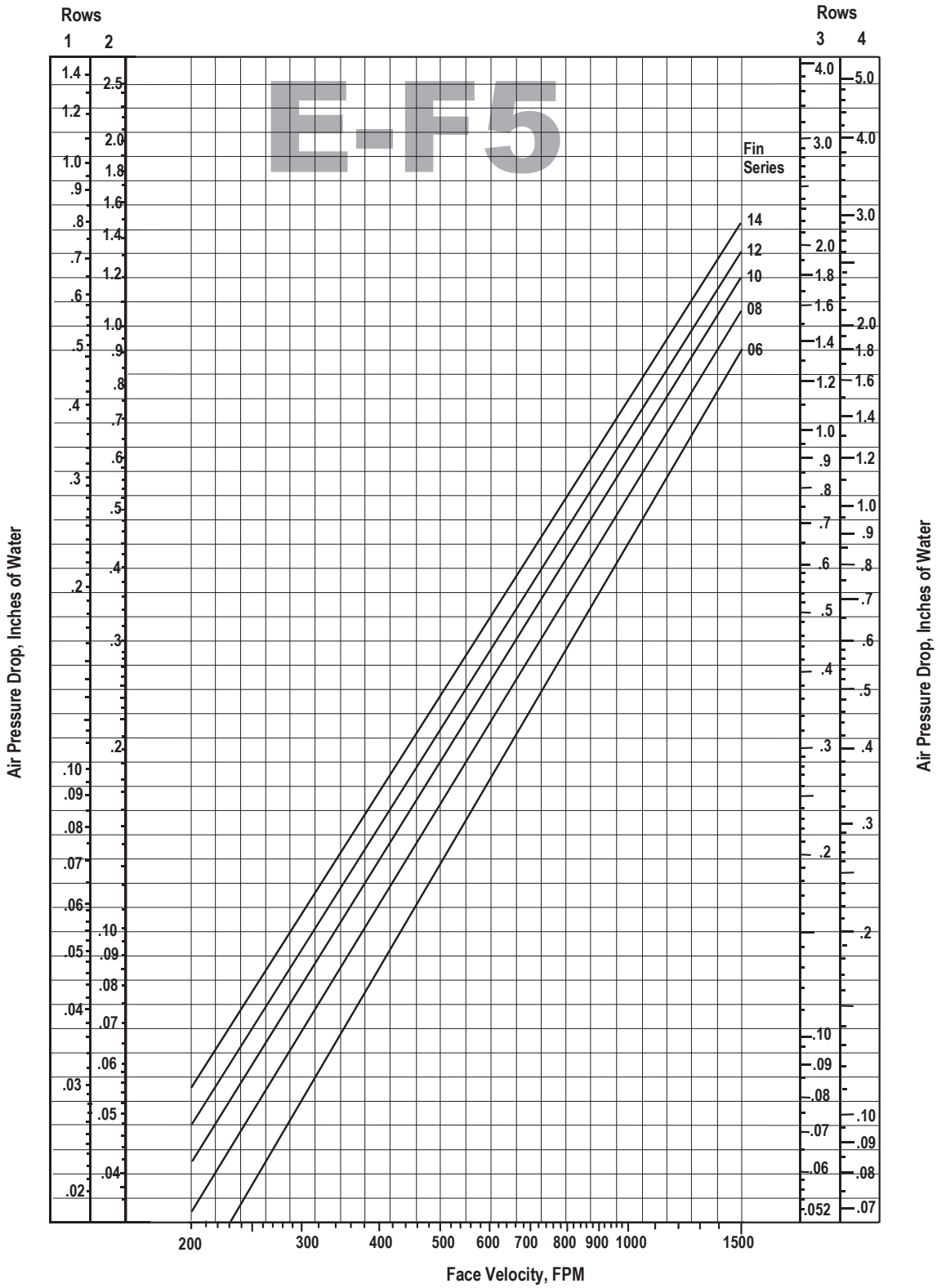

NOTE: Air pressure drop values for odd fin spacing.

Water Pressure Drop

Figure 12: Water Pressure Drop – 5B coils

AVG. WATER TEMP. (°F)	CORRECTION FACTOR
100	1.36
120	1.31
140	1.27
160	1.23
180	1.20
200	1.19
220	1.17
240	1.16
260	1.15
280	1.15
300	1.14

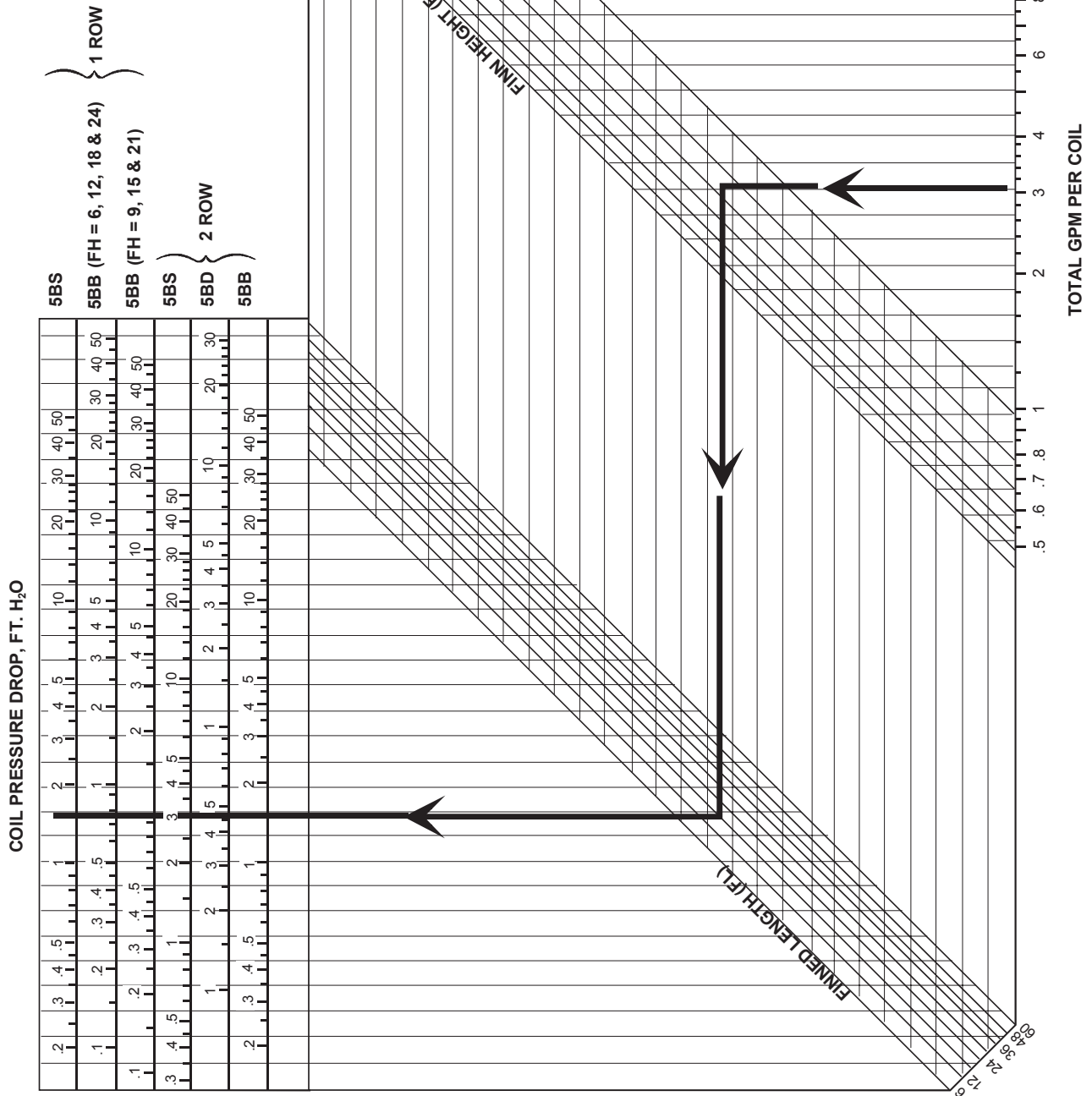

Figure 13: Water Pressure Drop – 5W and 5M Coils, 1- and 2-Row

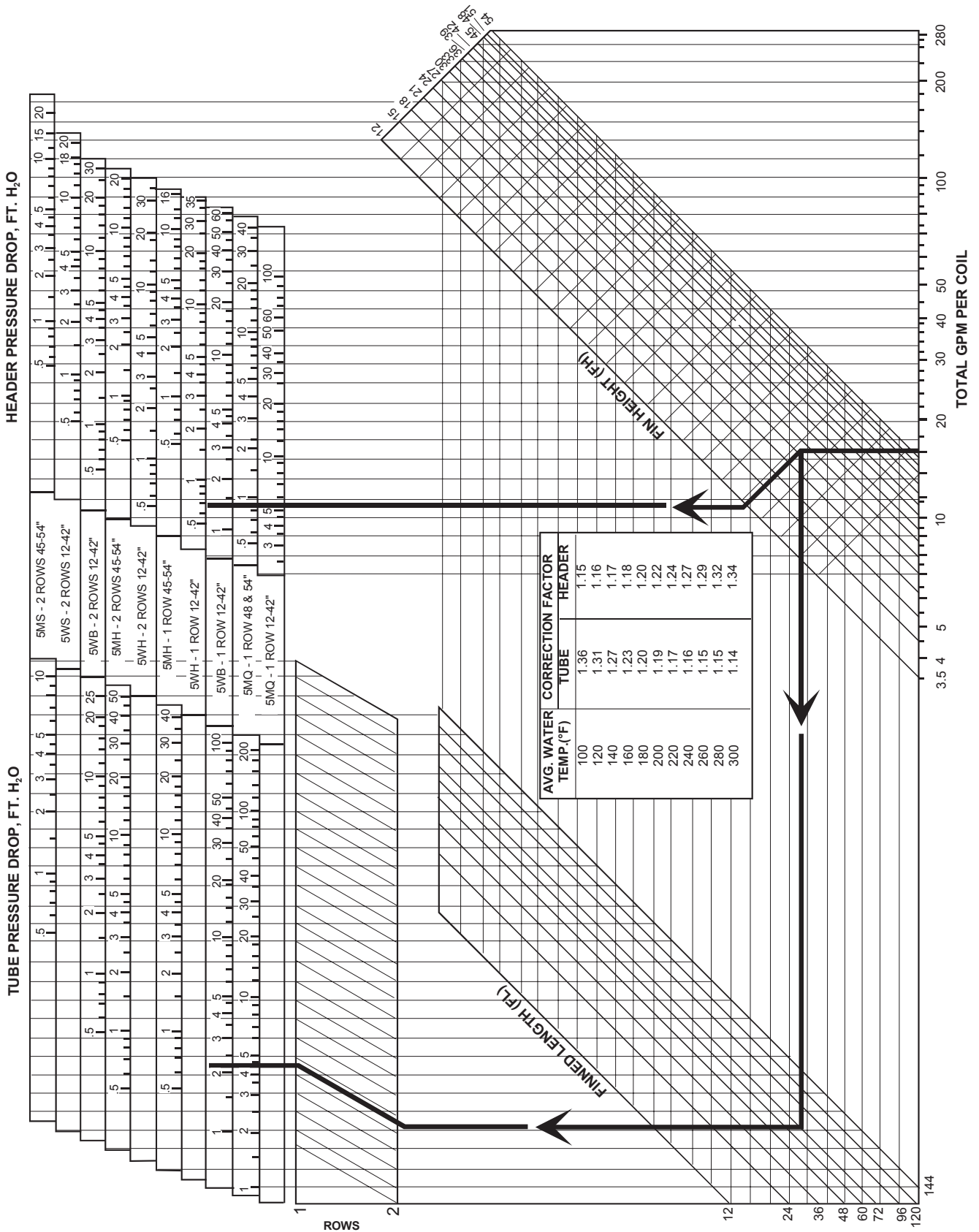
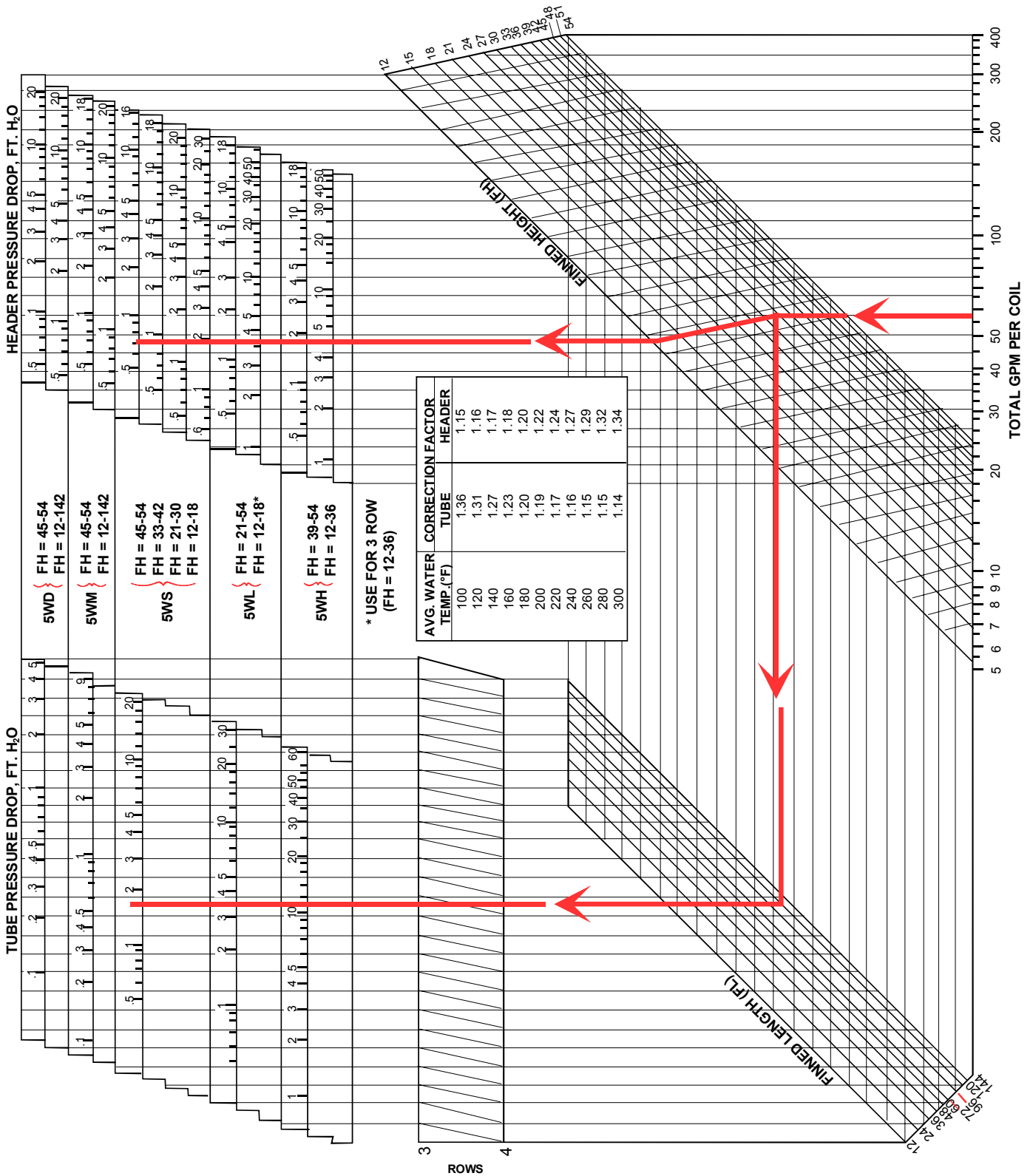

Figure 14: Water Pressure Drop – 5W Coils, 3- and 4-Row



Dimensional Data

Figure 15: 5W Coils – 1- and 2-Row (12" to 42" Fin Height)

Row	Model Type	Conn Size	A	B	E	W
1	5WH, 5WQ	1-1/2	2.75	2.67	2.67	12.00–42.00
1	5WB	1-1/2	2.75	3.42	3.42	12.00–42.00
2	5WH, 5WS	2-1/2	3.38	3.17	3.17	12.00–42.00
2	5WB	2-1/2	3.38	3.92	3.17	12.00–42.00

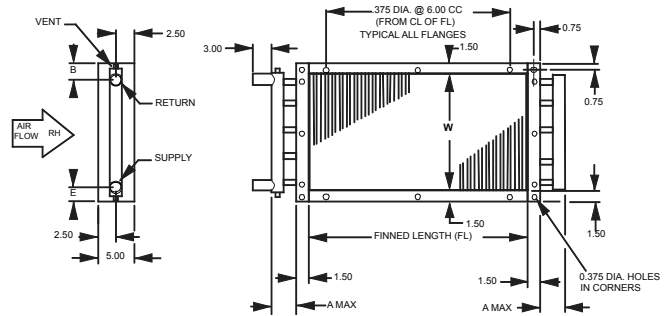

Figure 16: 5K, 5P, 5Q Cleanable Coils – 1- and 2-Row (12" to 42" Fin Height)

Row	Model Type	Conn Size	A	B	E	W
1	5PH, 5PQ	1-1/2	2.75	2.67	2.67	12.00–42.00
1	5QH, 5QQ	1-1/2	2.75	2.67	2.67	12.00–42.00
1	5KH, 5KQ	1-1/2	2.75	2.67	2.67	12.00–42.00
2	5PH, 5PS	2-1/2	3.38	3.17	3.17	12.00–42.00
2	5QH, 5QS	2-1/2	3.38	3.17	3.17	12.00–42.00
2	5KH, 5KS	2-1/2	3.38	3.17	3.17	12.00–42.00

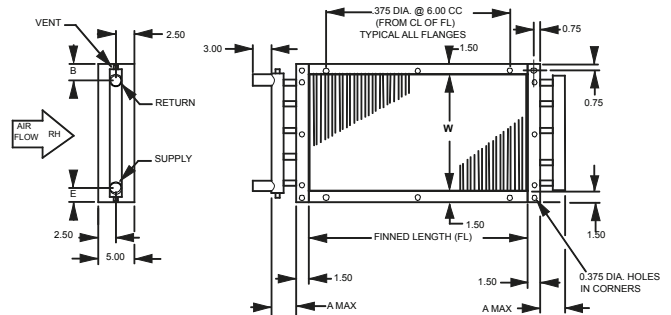
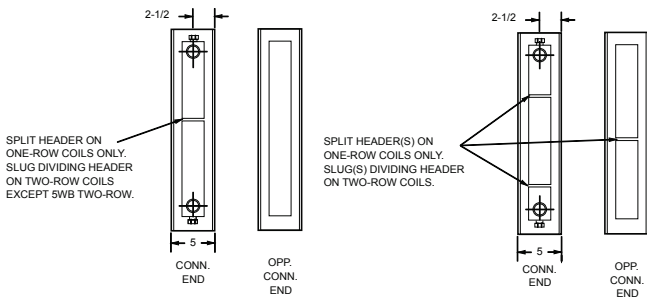

Figure 17: Header Arrangements (inches)

Type	
1-Row	2-Row
5WB	5WB
5WH	5WS
5KH	5KS
5PH	5PS
5QH	5QS

Type	
1-Row	2-Row
5WQ	5WH
5KQ	5KH
5PQ	5PH
5QQ	5QH



General Notes:

1. Vertical or horizontal airflow must be specified.
2. All coils drainable.
3. Connect coils for counterflow, i.e., Entering water conn. or leaving water conn. on leaving air side of coil.
4. Connections are pipe, NPT (ext.).
5. All dimensions are in inches.
6. Connection location ± 0.125.
7. Vent 1/4 NPT.
8. Type 5KQ, 5KH & 5KS coils have removable plugs on both ends.
9. Type 5PQ, 5PH & 5PS coils have removable plugs on connection end only.
10. Type 5QQ, 5QH & 5QS coils have removable plugs on opposite connection end only.
11. Type 5K, 5P & 5Q 1- and 2-row cleanable heating coils are outside the scope of AHRI standard 410.

Figure 18: 5W Coils – 3 and 4-Row (12" to 54" Fin Height)

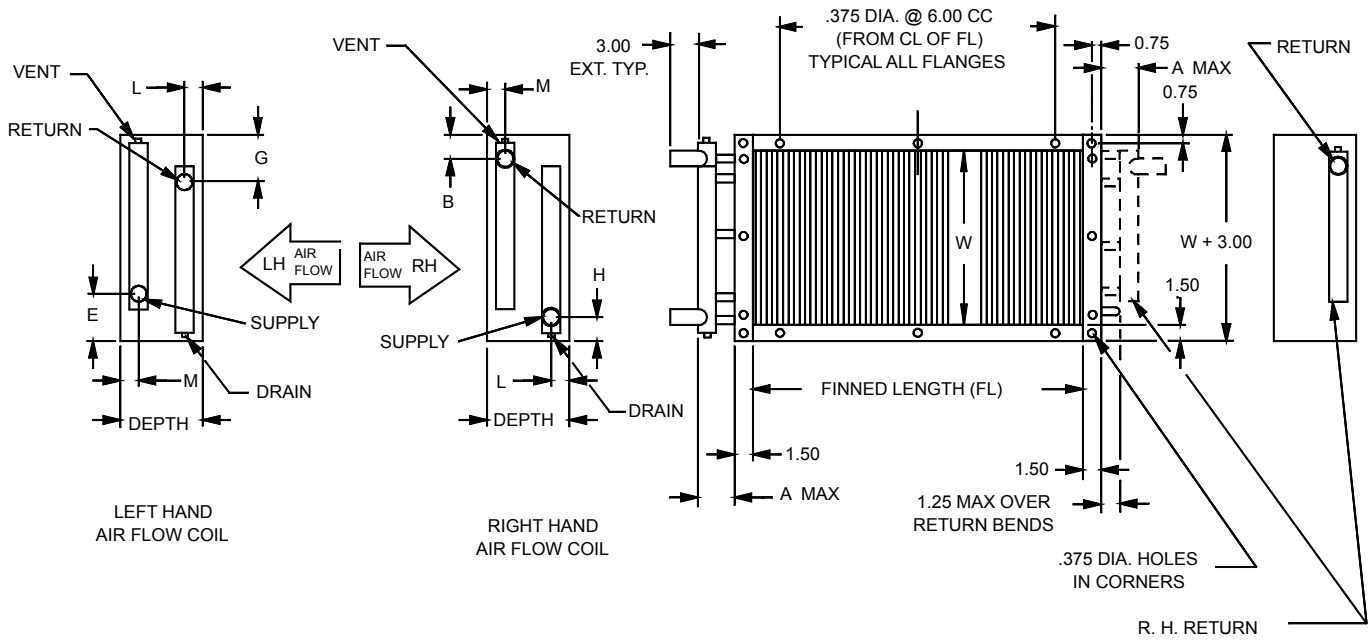

General Notes:

1. Vertical or horizontal airflow must be specified.
2. All coils drainable.
3. Connect coils for counterflow, i.e., Entering water conn. or leaving water conn. on leaving air side of coil.
4. Connections are pipe, NPT (Ext.).
5. All dimensions are in inches.
6. Connection location ± 0.125 .
7. Vent 1/4 NPT.

Table 5: 5WH Coils Variable Dimensions

Row	3	4	Air Flow	W Dimensions
Depth	6.00	7.50		
L	1.7	1.8	Horz. & Vert. Air Flow	N/A
M	1.7	1.8		
E	6.05	6.05	Horz. Air Flow	12.0–36.0
G	5.3	6.05		
E	6.3	6.3		
G	5.55	6.3		
E	6.05	6.05	Vert. Air Flow	12.0–36.0
G	5.3	6.05		
H	3.05	2.3		
E	6.3	6.3		
G	5.55	6.3		
H	3.3	2.55		

Horizontal Air Flow				
Conn Size	A	B	H	W
1-1/2	3.0*	2.3	2.3	12.0–36.0
2	3.5*	2.55	2.55	39.0–54.0

* 3 Row A = 3.50 for 1-1/2" Conn.; 4.0 for 2" Conn.

Vertical Air Flow			
Conn Size	A	B	W
1-1/2	3.00*	2.30	12.0–36.0
2	3.50*	2.55	39.0–54.0

* 3 Row A = 3.50 for 1-1/2" Conn.; 4.0 for 2" Conn.

Table 6: 5WL Coils Variable Dimensions

Row	Depth	Conn Size	A	B	E	G	H	L	M	W
3	6.0	1-1/2	3.0	2.3	4.55	3.8	2.3	1.7	1.7	12.0–36.0
	6.0	2	3.5	2.55	4.8	4.05	2.55	1.7	1.7	39.0–42.0
	7.5	2-1/2	3.63	2.8	5.05	4.3	2.8	2.2	1.8	45.0–54.0
4	7.5	1-1/2	3.0	2.3	4.55	4.55	2.3	1.8	1.8	12.0–18.0
	7.5	2	3.5	2.55	4.8	4.8	2.55	1.8	1.8	21.0–30.0
	7.5	2-1/2	3.63	2.8	5.05	5.05	2.8	1.8	1.8	33.0–54.0

Table 7: 5WS Coils Variable Dimensions

Conn Size	A	B	E	G	H	W
1-1/2	2.75	2.3	4.55	4.55	2.3	12.0–18.0
2	3.25	2.55	4.8	4.8	2.55	21.0–30.0
2-1/2	3.38	2.8	5.05	5.05	2.8	33.0–42.0
3	3.8	3.06	5.36	5.36	3.06	45.0–54.0

Row	3	4
Depth	6.0	7.5
L	1.7	1.8
M	1.7	1.8

Table 8: 5WM Coils Variable Dimensions

Fin Height	12.0–54.0
Row	4
Depth	8.5
L	1.78
M	2.3
A	4.0

Table 9: 5WD Coils Variable Dimensions

Fin Height	12.0–54.0
Row	4
Depth	8.5
L	1.78
M	2.3
A	3.75

Conn Size	A	B	E	G	H	W
2-1/2	3.38	2.8	2.8	2.8	2.8	12.0–42.0
3	3.75	3.06	3.06	3.06	3.06	45.0–54.0

Figure 19: 5M Coils — 1- and 2-Row with Splayed Headers (12" To 54" Fin Height)

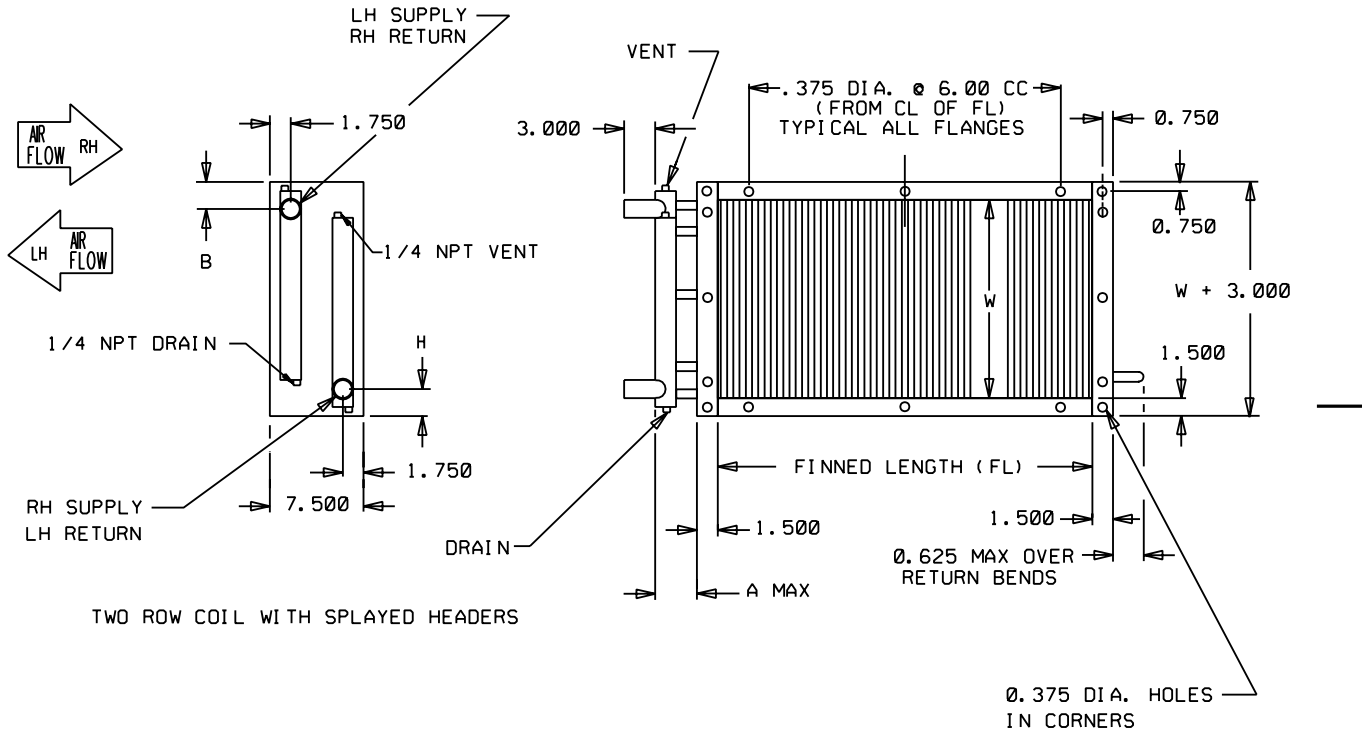

Table 10: 5M Coils — 1- and 2-Row with Splayed Headers Dimensions

Type	Row	Conn Size	A	B	H	W
5MS	2	1-1/2	3.0	2.313	2.313	12.0-18.0
	2	2	3.5	2.563	2.563	21.0-30.0
	2	2-1/2	3.63	2.813	2.813	33.0-42.0
	2	3	4.0	3.125	3.125	45.0-54.0
5MH	2	1-1/2	3.0	2.313	2.313	12.0-36.0
	2	2	3.5	2.563	2.563	39.0-54.0
5MQ	1	1-1/2	3.0	2.67	2.67	12.0-54.0 on 6.0 C/C
5MH	1	1-1/2	3.0	2.67	2.67	12.0-42.0 on 3.0 C/C
	1	2	3.5	2.92	2.92	45.0-54.0 on 3.0 C/C

Booster Coils

Figure 20: Flanged Casing without Sideplates

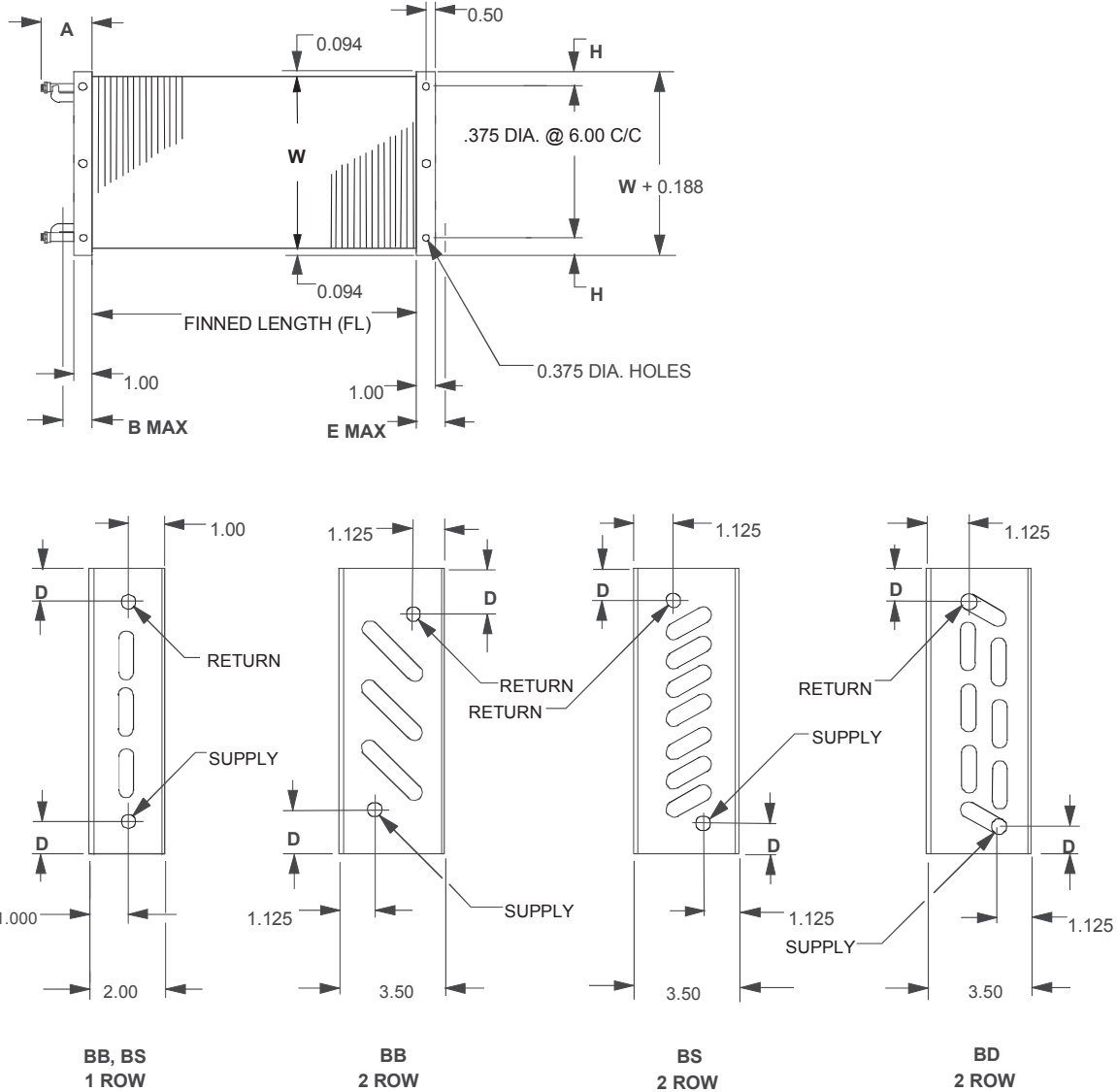

Table 11: Booster Coil Dimensions — Flanged Casing without Sideplates

Row	1			2		
Type	5BB		5BS	5BB	5BD	5BS
W DIM	6, 12, 18, 24	9, 15, 21	ALL	ALL	ALL	ALL
A	2.938	2.938	2.938	2.938	3.438	2.938
B	2.75	2.75	2.0	2.75	2.0	2.0
D	1.625	0.875	0.875	1.25	0.50	0.5
E	2.75	2.75	2.0	2.0	2.0	2.0

Table 12: Booster Coil Mounting Hole Dimensions — Flanged Casing without Sideplates

W	6	12, 18, 24	9,15, 21
H	0.844	3.094	1.594

Figure 21: Flanged Casing with Sideplates

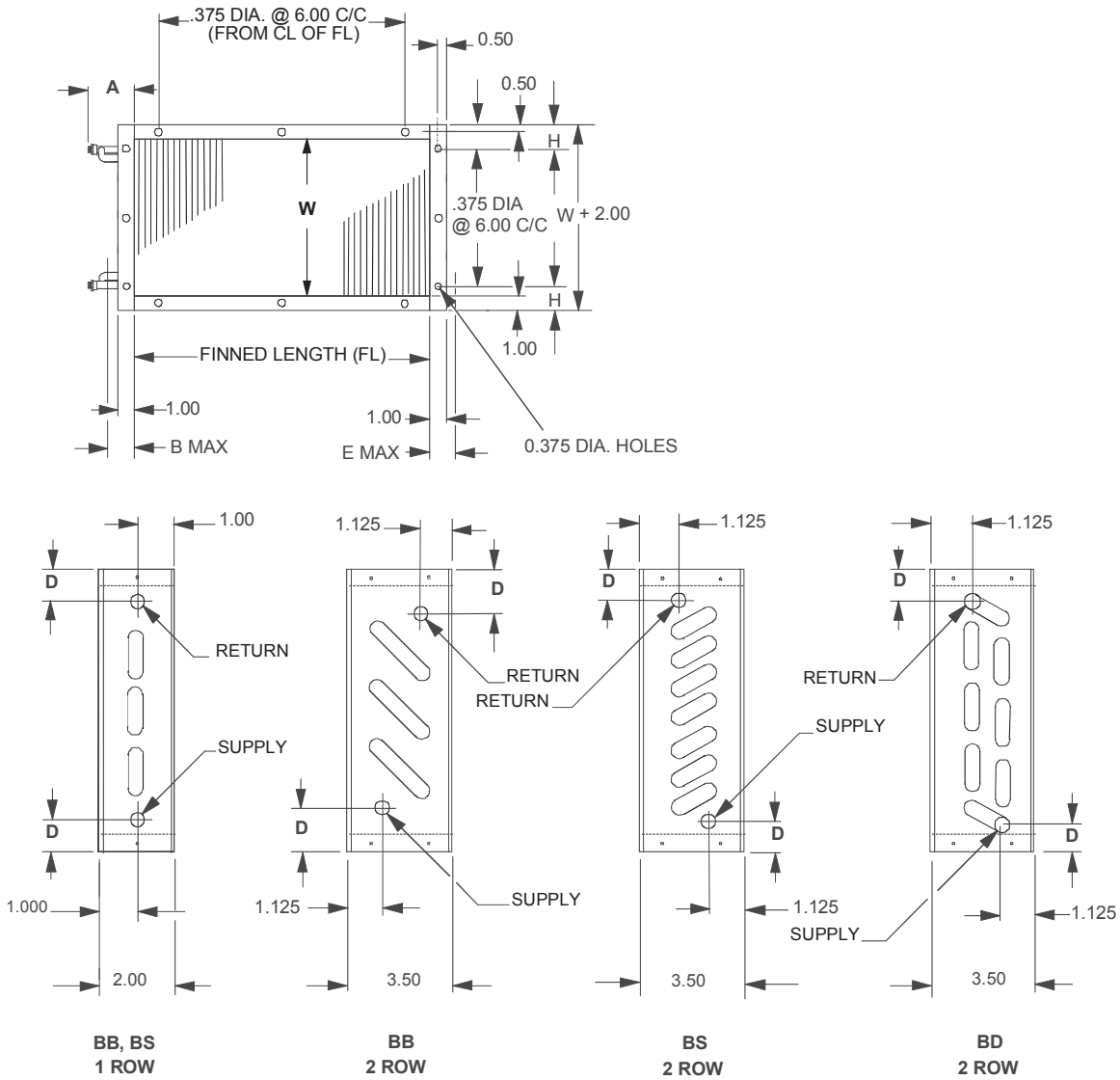

Table 13: Booster Coil Dimensions — Flanged Casing with Sideplates

Row	1			2		
	5BB		5BS	5BB	5BD	5BS
W DIM	6, 12, 18, 24	9, 15, 21	ALL	ALL	ALL	ALL
A	2.938	2.938	2.938	2.938	3.438	2.938
B	2.75	2.75	2.0	2.75	2.0	2.0
D	2.50	1.75	1.75	2.125	1.375	1.375
E	2.75	2.75	2.0	2.0	2.0	2.0

Table 14: Booster Coil Mounting Hole Dimensions — Flanged Casing with Sideplates

W	6	12, 18, 24	9, 15, 2
H	1.0	1.0	2.5

Figure 22: Slip Flange Casing

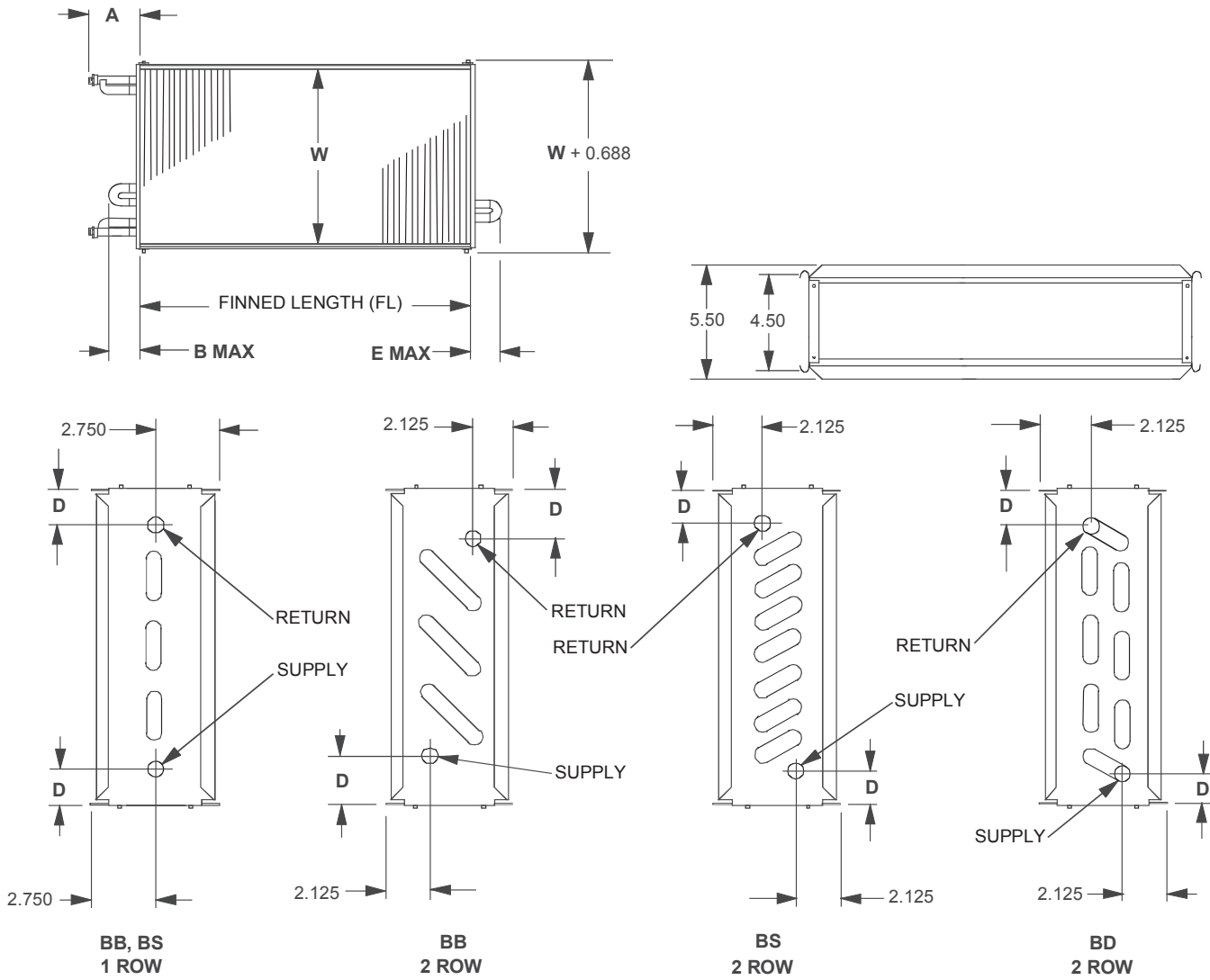

Table 15: Booster Coil Dimensions — Slip Flange Casing

Row	1			2		
	5BB		5BS	5BB	5BD	5BS
W DIM	6, 12, 18, 24	9, 15, 21	ALL	ALL	ALL	ALL
A	2.938	2.938	2.938	2.938	3.438	2.938
B	2.75	2.75	2.0	2.75	2.0	2.0
D	1.625	0.875	0.875	1.25	0.5	0.5
E	2.75	2.75	2.0	2.0	2.0	2.0

General Notes:

1. Connections are wrought copper, 1/2 NPT (Ext.).
2. All dimensions are in inches.
3. Connection location ± 0.125 .

Engineering Guide Specifications

Water Heating

PART 1: GENERAL

1.01 SECTION INCLUDES

- A. Water Heating Coil(s).
 1. 5WS, 5MS, 5WD, 5WH, 5WB, 5MH, 5MQ, 5WQ, 5WL, 5WM Coil Types.

1.02 SUBMITTALS

- A. Shop Drawings: Indicate coil fin height & length AND overall height, length and depth, connection sizes & location, flange mounting dimensions, and direction of airflow.
- B. Product Data.
 1. Certification - Acceptable coils are to be certified in accordance with ARI Standard 410 and bear the ARI label. Coils exceeding the scope of the manufacturer's certification and/or the range of ARI's standard rating conditions will be considered provided the manufacturer is a current member of the ARI Air-Cooling and Air-Heating Coils certification programs and that the coils have been rated in accordance with ARI Standard 410. Manufacturer must be ISO 9002 certified.
 2. Identify fin, tube & casing material type and thickness.
 3. Show coil weight (shipping & operating).
 4. State air and water flow amounts with its associated pressure drops.
 5. Indicate entering & leaving air and water temperatures.

1.03 QUALIFICATIONS

- A. Manufacturer: Company specializing in manufacturing water heating coils specified in this section must show a minimum five years experience and issues complete catalog data.

1.04 DELIVERY, STORAGE, AND HANDLING

- A. Deliver, store, protect and handle products to site.
- B. Accept products on site on factory-installed shipping skids. Inspect for damage.
- C. Store in a clean dry place and protect from weather and construction traffic. Handle carefully to avoid damage.

PART 2: PRODUCTS

2.01 ACCEPTABLE MANUFACTURERS

- A. Daikin Applied.
- B. Super Radiator.
- C. Trane.
- D. Carrier.
- E. York.

2.02 GENERAL DESCRIPTION

- A. Furnish as shown on plans and as described in the specification, Daikin Applied Water Heating Coils.
- B. Coils to have extended surface, staggered tube, and plate fin design.

2.03 HEADERS

- A. Made of seamless copper tubing to assure compatibility with primary surface.
- B. Headers to have intruded tube holes to provide maximum brazing surface for tube to header joint, strength, and inherent flexibility. Header diameter should vary with fluid flow requirements.
- C. Vent and drain plugs shall be provided on the coil header. For certain replacement air handler (Vision® Skyline® & some LSL models) coils the plugs will be provided on the coil connections. For replacement air handler (LSL/LHD) heating coils that are uncased, vent and drain plugs will not be provided.

2.04 CONNECTIONS

- A. Coil connection should be compatible with the piping to the coil to minimize chance of "galvanic action/electrolysis".
- B. Connections shall be a diameter adequate for specified gpm flow.
 1. The connections are located to permit [universal] [right hand] [left hand] mounting of the coil and assure equal pressure through all the circuits.
- C. Connection and material type.
 1. Connection material to be [carbon steel pipe] [copper tube] [red brass pipe]. Connection type to be [threaded] [Victaulic] [butt welded] [outside diameter female (ODS) sweat] [outside diameter male (ODM) sweat].
- D. Coils are circuited to provide maximum mean effective temperature difference for heat transfer rates.
- E. Coils, greater than 2 rows, must be arranged for counter flow.

2.05 TESTING AND PRESSURE RATINGS

- A. Completed coils are tested at a minimum of 315 PSIG air pressure while submerged in warm water.
- B. Hydronic tests alone are not acceptable.

- C. Standard coil construction is rated for [250 PSIG working pressure up to water temperatures of 300 degrees] [250 PSIG working pressure up to water temperatures of 200 degrees F and 200 PSIG working pressure at water temperatures between 200 and 300 degrees F].

2.06 CAPACITY

- A. Coil capacity shall be as outline on the project schedule and confirmed with computer generated output.
- B. Application.
 - 1. Heating.
- C. Fluid Type.
 - 1. [Water] [Ethylene Glycol] [Propylene Glycol].

2.07 PRIMARY SURFACE

- A. Tubes to be 5/8" O.D., staggered in direction of airflow, and must be on 1½" tube centers. [Note: 5WB coil is on 3.00" tube centers].
- B. Wall thickness to be [0.020"] [0.025"] [0.035"] [0.049"] nominal [copper] [admiralty copper] [cupronickel] and water pressure drop of coil selection adjusted to wall thickness specified.
- C. Tubes to be mechanically expanded in to fin collars to provide a continuous primary to secondary compression bond over entire coil length, assuring maximum heat transfer.
- D. Coil Tube Type.
 - 1. Standard [smooth bore] [smooth bore with internal brass spring turbospirals].

2.08 SECONDARY SURFACE

- A. Plate style fins shall be corrugated for high capacity and structural strength.
 - 1. Fin thickness shall be [0.0075"] [0.0095"] [0.006"] [aluminum] [copper].
- B. The fins to have collars to determine fin spacing per inch and support the heat transfer bond to primary surface. Tubing should not be visible between the fins.
 - 1. Fin Style to be a [Flat] [New Ripple] [Hi-F] fin type.

2.09 COIL TYPE & SERPENTINE

- A. [5WH - Half Serpentine] [5WS - Single Serpentine] [5MS - Single Serpentine with Splayed Headers] [5WD - Double Serpentine] [5WB - Half Serpentine with rows on 3.00" tube centers] [5MH - Half Serpentine with Splayed Headers] [5MQ - Quarter Serpentine] [5WQ - Quarter Serpentine] [5WL - Three Quarter Serpentine] [5WM - One and One Half Serpentine].
- B. Coils available from 12" to 54" fin height on 1.5" tube centers and on 3" increments.
- C. All water heating coils with standard 0.020" nominal copper tubing available from 12" to 216" fin length in two decimal point increments. For other tube material types the maximum tube length is 180".

2.10 CASINGS

- A. Casing Style
 - 1. [Contractor Coil with flanged casing] [Contractor Coil uncased] [Air Handler unit coil w/ flanged casing designed for [LSL/MSL] [Vision®/Skyline®] [Roofpak] replacement applications] [Air Handler unit coil uncased designed for [LSL/LHD] [Vision®/Skyline®] replacement applications].
- B. Casing Material.
 - 1. [Galvanized Steel] [Copper] [Aluminum] [Stainless Steel].

2.11 PROTECTIVE COATINGS

- A. [None, specified coil and casing material only] [Entire coil assembly coated with an epoxy coating. The coating shall be electrodeposited to obtain a nominal dry film thickness of 0.001" +/- 0.0002" (mils). The coating shall be free from voids, checks, cracks, and blisters. The quality and application shall be such that any portion of the coil will meet a minimum 2000 hours of 5% salt spray testing to American society for Testing and materials (ASTM) B117 under the following criteria: A) No loss of coating adhesion and no evidence of attack to the fin proper. Only 5% of the fin collars may show corrosion product. B) Complete deterioration of the sample in any location is considered failure of the part on this test, and shall be cause for rejection].

2.12 PACKAGING

- A. [Coil(s) to be fully crated in a wood enclosure with protective cardboard covering the finned area] [Coil(s) to be fully crated in a wood enclosure with protective cardboard covering the finned area. The wood enclosure shall be capable of being removed and re-used (Note: Must be used for coated coils)].

PART 3: EXECUTION

3.01 INSTALLATION

- A. Install in accordance with manufacturer's recommendations.

Water Heating Booster Coils

PART 1: GENERAL

1.01 SECTION INCLUDES

- A. Water Heating Booster Coils.

1.02 SUBMITTALS

- A. Shop Drawings: Indicate coil fin height & length AND overall height, length and depth, connection sizes & location, flange mounting dimensions, and direction of airflow.
- B. Product Data.
 1. Certification - Acceptable coils are to be certified in accordance with ARI Standard 410 and bear the ARI label. Coils exceeding the scope of the manufacturer's certification and/or the range of ARI's standard rating conditions will be considered provided the manufacturer is a current member of the ARI Air-Cooling and Air-Heating Coils certification programs and that the coils have been rated in accordance with ARI Standard 410. Manufacturer must be ISO 9002 certified.
 2. Identify fin, tube & casing material type and thickness.
 3. Show coil weight (shipping & operating).
 4. State airflow, water flow, and respective pressure drops.
 5. Indicate entering & leaving air and fluid temperatures.

1.03 QUALIFICATIONS

- A. Manufacturer: Company specializing in manufacturing Water Heating Booster Coils specified in this section must show a minimum five years experience and issues complete catalog data.

1.04 DELIVERY, STORAGE, AND HANDLING

- A. Deliver, store, protect and handle products to site.
- B. Accept products on site on factory-installed shipping skids. Inspect for damage.
- C. Store in a clean dry place and protect from weather and construction traffic. Handle carefully to avoid damage.

PART 2: PRODUCTS

2.01 ACCEPTABLE MANUFACTURERS

- A. Daikin Applied.
- B. Super Radiator.
- C. Trane.
- D. Carrier
- E. York.

2.02 GENERAL DESCRIPTION

- A. Furnish as shown on plans and as described in the specification, Daikin Applied Water Heating Booster Coils.
- B. Coils to have extended surface, staggered tube, and plate fin design.

2.03 HEADERS

- A. Water Heating Booster Coils shall be designed for low flow and headers are not required nor furnished.

2.04 CONNECTIONS

- A. Coil connection should be compatible with the piping to the coil to minimize chance of "galvanic action/ electrolysis".
- B. Connections to be copper and should be a diameter adequate for specified gpm flow.
- C. Connections to be [wrought copper male threaded 0.5" N.P.T. fittings] [male sweat 0.5" O.D.M.].
- D. Connections located to permit universal mounting of the coil and assure equal pressure through all circuits.
- E. Coils are circuited to provide maximum mean effective temperature difference for heat transfer rates.

2.05 TESTING AND PRESSURE RATINGS

- A. Completed Water Heating Booster Coils are leak tested at a minimum of 320 PSIG air pressure, allowed to settle, and monitored for pressure loss. The loss cannot exceed .050 PSI.
- B. Standard coil construction is rated for [250 PSIG working pressure up to water temperatures of 300 degrees] [250 PSIG working pressure up to water temperatures of 200 degrees F and 200 PSIG working pressure at water temperatures between 200 and 300 degrees F].

2.06 CAPACITY

- A. Coil capacity shall be as outline on the project schedule and confirmed with computer generated output.

2.07 PRIMARY SURFACE

- A. A. Tubes to be 5/8" O.D. copper, staggered in direction of airflow, and must be on 1½" tube centers (5BB on 3" centers).
- B. Wall thickness to be [0.020"] [0.025"] [0.035"] nominal and water pressure drop of coil selection adjusted to wall thickness specified.
- C. Tubes to be mechanically expanded in to fin collars to provide a continuous primary to secondary compression bond over entire coil length, assuring maximum heat transfer.

2.08 SECONDARY SURFACE

- A. Plate style fins shall be corrugated for high capacity and structural strength.
- B. Fin thickness shall be [0.0075"] [0.006"] [0.0095"] [aluminum] [copper].
- C. The fins to have collars to determine fin spacing per inch and support the heat transfer bond to primary surface. Copper tubing should not be visible between the fins.

2.09 COIL TYPE & CIRCUITING

- A. [5BB one and two row coils, single circuiting, 3" tube center-to-center from 6" to 24" fin height.] [5BD one and two row coils, double circuiting, 1.5" tube center-to-center from 6" to 24" fin height.] [5BS one and two row coils, single circuiting, 1.5" tube center-to-center from 6" to 24" fin height.]
- B. All booster coils available from 6" to 60" fin length in two decimal point increments.

2.010 CASINGS

- A. Coil casing to be galvanized steel [with slip joint flange] [flanged with side plates] [flanged without side plates] and back break to maximize casing strength.

PART 3: EXECUTION

3.01 INSTALLATION

- A. Install in accordance with manufacturer's recommendations.



Daikin Applied Training and Development

Now that you have made an investment in modern, efficient Daikin equipment, its care should be a high priority. For training information on all Daikin Applied HVAC products, please visit us at www.DaikinApplied.com and click on Training, or call 540-248-9646 and ask for the Training Department.

Warranty

All Daikin Applied equipment is sold pursuant to its standard terms and conditions of sale, including Limited Product Warranty. Consult your local Daikin Applied representative for warranty details. To find your local Daikin Applied representative, go to www.DaikinApplied.com.

Aftermarket Services

To find your local parts office, visit www.DaikinApplied.com or call 800-37PARTS (800-377-2787). To find your local service office, visit www.DaikinApplied.com or call 800-432-1342.

This document contains the most current product information as of this printing. For the most up-to-date product information, please go to www.DaikinApplied.com.

Products manufactured in an ISO Certified Facility.