



## Catalog 726-8

### **PreciseLine® Horizontal and Vertical Air Handler**

**Models BCHD, BCVD, BCAD, BCHE and BCHU (600 to 10,000 CFM)**





<b>Nomenclature</b> .....	<b>3</b>	Vertical Unit Mounting Isolation.....	21
<b>Introduction to PreciseLine</b> .....	<b>4</b>	Access Panels and Doors.....	22
<b>Overview</b> .....	<b>5</b>	Piping and Coils .....	22
Available Features Breakdown .....	5	Hydronic Coil Connections .....	22
Double-Wall Cabinet Construction .....	6	Condensate Drain Pan Traps .....	24
Mixing Box .....	6	<b>Engineering Data</b> .....	<b>25</b>
Damper Actuator.....	6	Operation Limitations .....	25
Discharge Plenum.....	7	<b>Physical Data</b> .....	<b>28</b>
Factory-installed Valve Packages.....	7	Component Weights .....	28
Slide-Out Fan Assembly and Coil Section .....	8	Fan and Motor Data .....	31
<b>Options and Accessories</b> .....	<b>9</b>	Horizontal Filter Data .....	33
Electric Heat (Option) .....	9	Vertical Filter Data .....	33
Filter Options for Horizontal Units.....	11	<b>Unit Selection</b> .....	<b>34</b>
Filter Options for Vertical Units .....	12	<b>Performance Data</b> .....	<b>37</b>
<b>Application Considerations</b> .....	<b>14</b>	<b>Dimensional Data</b> .....	<b>51</b>
MicroTech 4 Lite		Size 006-050 Horizontal Unit Dimensions .....	51
Factory-Integrated Controller .....	14	Size 006-050 Vertical Unit Dimensions.....	60
Digital-Ready Features		Size 060-100 Unit Dimensions .....	67
(for field-installed controllers) .....	16	<b>Guide Specifications</b> .....	<b>80</b>
Mounting and Access .....	17		
Horizontal Unit Mounting Isolation .....	21		

©2023 Daikin Applied, Minneapolis, MN. All rights reserved throughout the world. This document contains the most current product information as of this printing. Daikin Applied Americas Inc. has the right to change the information, design, and construction of the product represented within the document without prior notice. For the most up-to-date product information, please go to [www.DaikinApplied.com](http://www.DaikinApplied.com).  
 ™® Magnitude, MicroTech, SiteLine, RapidRestore, and Daikin Applied are trademarks or registered trademarks of Daikin Applied Americas Inc. The following are trademarks or registered trademarks of their respective companies: BACnet from American Society of Heating, Refrigerating and Air-Conditioning Engineers, Inc.; Echelon, LonWorks, LonMark, and LonTalk from Echelon Corporation; Modbus from Schneider Electric; and Windows from Microsoft Corporation..

### AHRI Certification



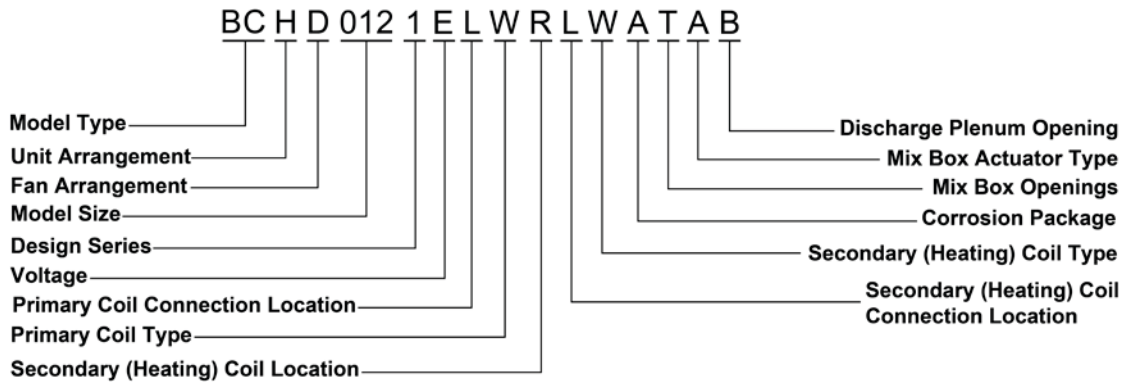
Units certified in accordance with Central Station Air-Handlers certification program, which is based on AHRI Standard 430.

### Agency Listed



All standard units  
 All Canadian units

# Nomenclature



Category	Code	Description
Model Type	BC	PreciseLine Air Handler
Unit Arrangement	H	Horizontal
	V	Vertical
Fan Arrangement	A	AVD / Compact Vertical (Sizes 006-020)
	D	Draw Thru
	E	Draw Thru Plenum Fan, End Discharge
Model Size	U	Draw Thru Plenum Fan, Up Discharge
	006	Nominal 600 CFM
	008	Nominal 800 CFM
	010	Nominal 1,000 CFM
	012	Nominal 1,200 CFM
	016	Nominal 1,600 CFM
	018	Nominal 1,800 CFM
	020	Nominal 2,000 CFM
	030	Nominal 3,000 CFM
	040	Nominal 4,000 CFM
	050	Nominal 5,000 CFM
	060	Nominal 6,000 CFM
080	Nominal 8,000 CFM	
100	Nominal 10,000 CFM	
Design Series	1	1st Vintage
Voltage	A	115/60/1
	E	208/60/1
	G	460/60/1
	K	230/60/1
	P	277/60/1
	D	208/60/3
	L	230/60/3
	T	460/60/3
Primary Coil Connection Location	W	575/60/3
	L	Left Hand (Air back of the head)
	R	Right Hand (Air back of the head)
	C	Center

Category	Code	Description
Primary Coil Type	W	Water / Glycol
	D	DX / 410A
	V	VRV
Secondary (Heating) Coil Location	P	Preheat
	R	Reheat
	Y	None
Secondary (Heating) Coil Connection Location	L	Left Hand (Air back of the head)
	R	Right Hand (Air back of the head)
	Y	None
Secondary (Heating) Coil Type	C	Center
	W	Hot Water / Glycol
	Y	None
Corrosion Package	S	Steam
	A	(Coil Casing) Stainless / (Fin Coating) None / (Drip Pan Corrosion Pkg.) Stainless
Mix Box Openings	Y	(Coil Casing) Galvanized / (Fin Coating) None / (Drip Pan Corrosion Pkg.) Galvanized
	T	Top + Rear
Mix Box Actuator Type	B	Bottom + Rear
	Y	None
	T	ON/OFF
Discharge Plenum Opening	A	0-10V M
	M	Manual
	Y	None
	B	Bottom
	T	Top
	E	End
	Y	None - No Discharge Plenum
	R	Right Hand (Air back of the heat)
L	Left Hand (Air back of the head)	
	F	Field Cut-Out (Has a Plenum)

NOTE: Not all code options shown.

## Introduction to PreciseLine

PreciseLine horizontal and vertical air handlers combine performance, versatility, and economy thanks to innovative and intentional design. The thermally-broke, double-wall cabinets allow PreciseLine units to supplement or anchor any project in the configurable/semi-custom air handler space.

### Blower Coil Cabinets (Sizes 006 – 020)

- 300-2,000 CFM
- Up to 3" of TSP
- Max height of 18" for plenum installation (for AVD)
- Dozens of coil configurations available

### Light Air Handlers (Sizes 030 – 050)

- 1,000-5,000 CFM
- Up to 5" TSP
- Forward-curved and welded aluminum airfoil plenum fans available

### Configurable Air Handlers (Sizes 060 – 100)

- 3,000-10,000 CFM
- Up to 5" TSP
- Low-leak dampers come standard; optional economizer, exhaust fans, and final filter

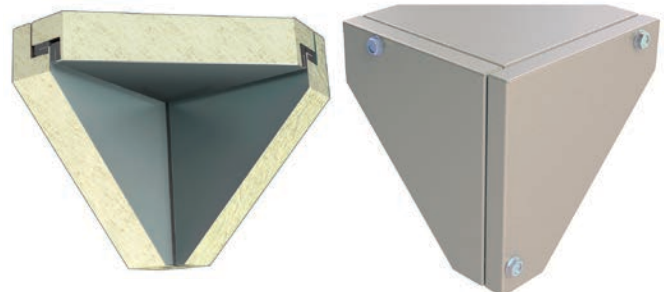


## Wall-to-Wall Innovation

Each PreciseLine air handler is designed to make the most of every inch occupied in your space with no concessions on efficiency, capacity, or performance.

### Thermal Integrity

- Thermally-broke, double-wall design means no metal-to-metal conduction between interior and exterior panels and prevents risk of mold/mildew
- Durable foam-injected panel walls for R-6.5 thermal resistance, structural reinforcement, and sound dampening
- Fully gasketed for complete air seal



1-inch thick foam-injected cabinet panel insulation

### No-Fuss Maintenance and Inspection

- Sheet metal interior for easy wipe-down
- Quarter-turn (toolless) panel door latches
- Slide-out rail for access to fan and coils (see [page 8](#))
- Single-side access available on vertical units

### Higher Capacity, Smaller Footprint

- Foam-injected panels allow for 1" panel thickness with no compromise to thermal efficiency.
- Standard unit performance from 300 CFM to 10,000 CFM

### Premium Features Available

- Mixing box with manual or modulating damper control
- High-efficiency, direct-drive EC motors
- Factory-integrated controls
- Welded aluminum airfoil plenum fans

### Certifications

- Full compliance with ASHRAE 62.1-2010 for high indoor air quality
- Units are ETL and cETL listed
- Performance is AHRI 430 certified

# Overview

## Available Features Breakdown

Cabinet	UNIT SIZES		
	006-020	030-050	060-100
1" double-wall paneling with R-6.5 rating	✓	✓	✓
Powder-coated finish	✓	✓	✓
AMCA 1 damper leakage rating			✓
Mixing box with manual, On/Off, or modulating damper control (excluding sizes 006-020 and 060-100 verticals)	✓	✓	✓
Economizer			✓
Discharge plenum with sound reduction package	✓	✓	✓
2" or 4" filters available in MERV 4, 8, or 13	✓	✓	✓
Final filter			✓
Fans and Motor	006-020	030-050	060-100
Premium efficiency direct drive EC motors	✓	✓	✓
Single-phase power	✓		
Three-phase power		✓	✓
DWDI forward-curved supply fans	✓	✓	
Welded aluminum airfoil plenum fans		✓	✓
DWDI forward-curved exhaust fans			✓
Field-adjustable 3-speed fan control	✓		
Modulating fan control	✓	✓	✓
Capable of TSP up to 3.0" w.g.	✓	✓	✓
Capable of TSP up to 5.0" w.g.		✓	✓
Cooling	006-020	030-050	060-100
2, 4, or 6-row hydronic primary coil	✓	✓	✓
8-row hydronic primary coil		✓	✓
FPT field connections	✓		
Sweat field connections	✓	✓	✓
3-row DX and VRV cooling coils	✓	✓	✓
6-row DX cooling coils	✓	✓	✓
Factory-installed valve packages	✓		
Heating	006-020	030-050	060-100
1 or 2-row hydronic secondary heating coil (preheat or reheat)	✓	✓	✓
1-row steam secondary heating coil	✓	✓	✓
Electric heat with On/Off or SCR modulating control	✓	✓	✓
Controls	006-020	030-050	060-100
Digital-ready controls	✓	✓	✓
Factory-integrated controls	✓	✓	✓
Single-point power	✓	✓	✓



Sizes 006-020  
(Vertical Model Shown)



Sizes 030-050  
(Vertical Model Shown)



Sizes 060-100

## Double-Wall Cabinet Construction

Many competitor units offer single-wall panels lined with thin, adhesive-back foam or fiberglass insulation. Daikin Applied PreciseLine units utilize a galvanized double wall, 1-inch foam injected, thermally isolated panel. This panel construction means more thermal insulation, raising the cabinet's thermal resistance to R-6.5. This thermal resistance is more effective at keeping air cold in cooling mode and hot when in heating mode. Traditional single wall fiber-faced insulation allows heat to flow in and out of the cabinet more easily, heating up cold air in cooling, and cooling down hot air in heating. PreciseLine's thermally insulated cabinetry helps keep insulation fibers from entering the air stream, reducing the chance of pathogens in the system, providing a cleanable surface, and increased panel rigidity for long-life. Foam injected insulation conforms to ASTM C1071 (including C665, UL 181 for erosion, and 25/50 rating for flame spread/smoke developed per ASTM E-84, UL 723 and NFPA 90A.

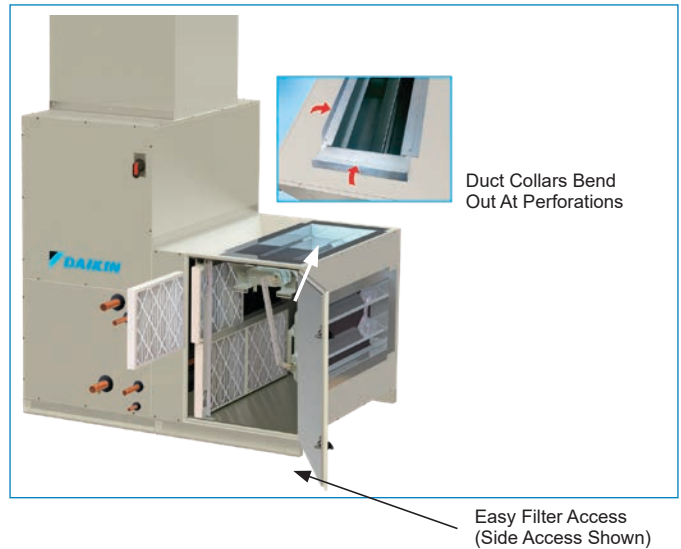
## Mixing Box

The Daikin branded air handling unit can be configured with an optional factory-installed mixing box. The mixing box is perfect for economizer operation, satisfying outdoor air requirements via mixing of indoor and outdoor air. The mix box is constructed of Daikin Applied's innovative 1-inch thick foam injected, double wall panel.

Note: Sizes 060-100 have dual actuators.



The mix box duct collar is flush with the cabinet and easily bends out along the perforations by the installer, reducing time and labor.



## Damper Actuator

Damper actuators for mixing box control are factory-installed and wired. Control styles include 24 VAC (ON/OFF) and 0-10VDC fully modulating for economizing control. The damper actuators are spring return and field-reversible. A manual damper is also available for fixed damper applications. Coil freeze protection is the responsibility of the installing party and must be carefully considered when using this unit to condition outdoor air. Actuators listed under UL 873, CE, CSA, and C22.2.

On unit sizes 06-20, the damper actuator is located on the side opposite the coils. On unit sizes 30-100, the actuator is located on the same side as the coils.



## Discharge Plenum

Daikin Applied offers an optional discharge plenum, factory mounted and shipped assembled on the discharge end of the main unit. The plenum is available in multiple discharge configurations. It can be ordered with an industry-leading sound-attenuation package, minimizing sound amplitude and improving sound quality. Competitor models require plenums or discharge sections to be field fabricated in order to turn the discharge air, adding fabrication and labor costs, with no sound dampening option.



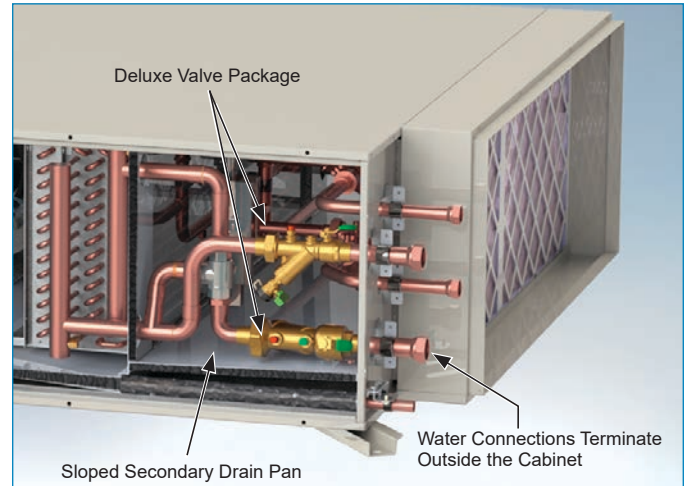
Multiple discharge configurations on horizontal plenums (Duct collars shown in bent out position)



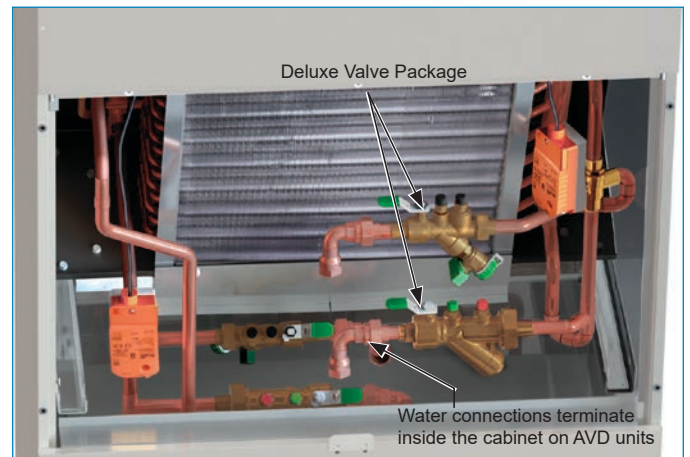
Note: Top Discharge Only

## Factory-installed Valve Packages

Factory valve and piping packages are available for both two-pipe and four pipe systems for sizes 020 and smaller. All factory assembled packages are leak tested and ship supported by an expandable foam agent. The valve packages are assembled inside the cabinet and water connections terminate outside the cabinet for quick field hook-up. Valve piping is easily accessible through a single panel, for easy service. A secondary sloped drain pan covers the span of the internal valve package making pipe insulation unnecessary for the piping package inside of the cabinet.



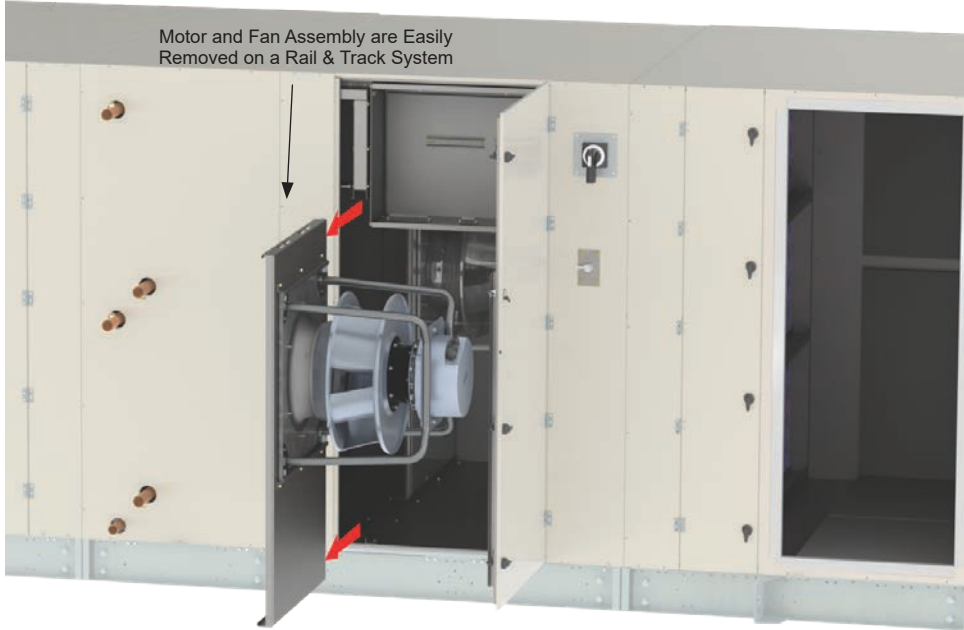
Valve packages provide added value by reducing installing contractors time. Connection points are pre-determined, allowing the building supply and return piping to be pre-installed before the arrival of the air handler.



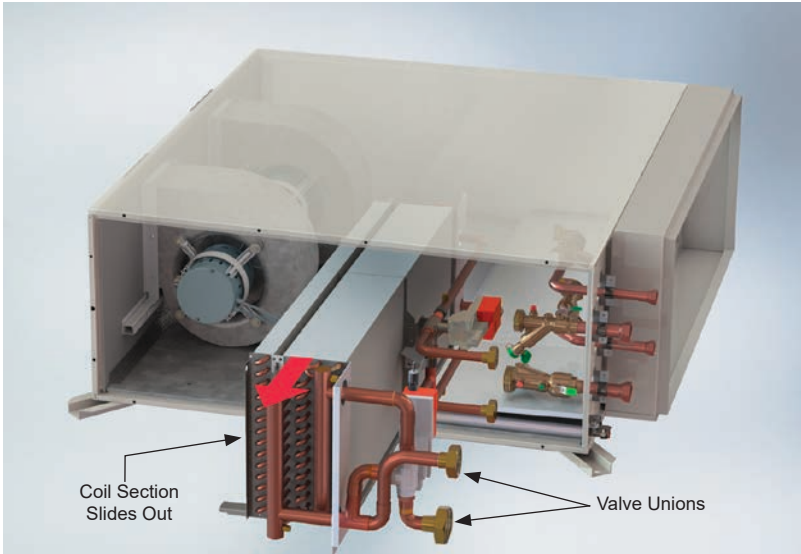


## Slide-Out Fan Assembly and Coil Section

The DWDI forward-curved and plenum fans are installed on a sub-assembly that can slide out independently on a rail and track system for easy maintenance



The coil section assembly slides out providing easy service and maintenance access. Valve package unions disconnect on the coil piping side, and the coil removed without disrupting the buildings supply and return water connections.



# Options and Accessories

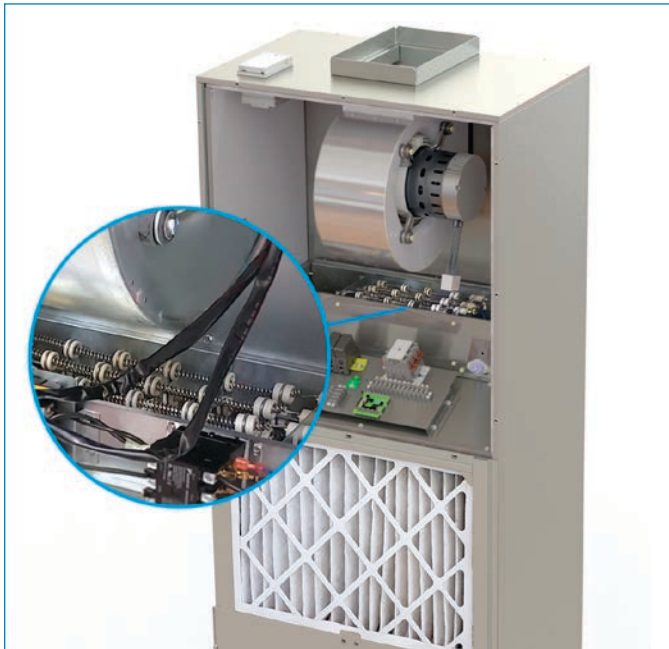
## Electric Heat (Option)

The optional factory-installed electric heat section consists of an open coil heater rack mounted to the units' primary coil. The heating coil is in the preheat position for horizontal units and the reheat position for vertical units. Electric heat is designed to operate only when the supply fan is running, heating the air as it passes through the heating elements. The electric heat section consists of the mounting rack, electric elements, contactor, optional SCR module and the manual and automatic reset thermal limits with multiple on-board control systems for safety. Electric heat comes pre-wired to the main control box for a single point power connection to the unit.

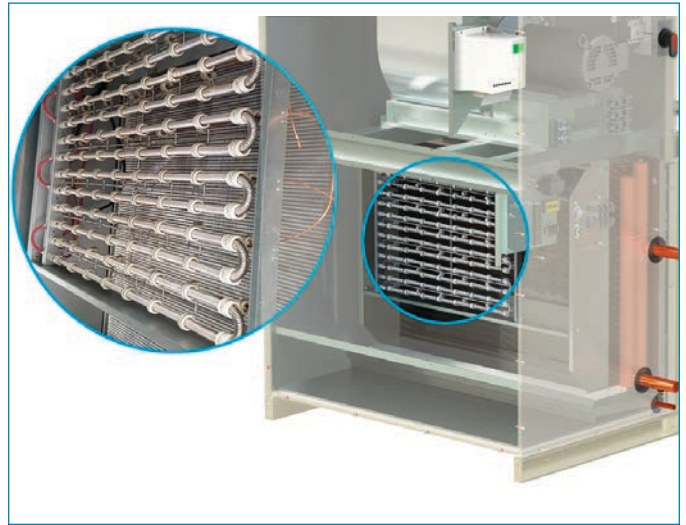
Available in a wide range from 1-133kW, these heating elements can be controlled with a 24 VAC ON/OFF signal, 4-stage ON/OFF signal (sizes 060-100), or with a 0-10VDC, fully modulating Silicone Controlled Rectifier (SCR). The SCR modulates the electric heat element which means no noisy relays clicking on and off, precise temperature control, increased thermal comfort and improved energy efficiency. Electric heat is available on 2-pipe systems only.

Size 60 to 100 units require dual-point power for electric heat.

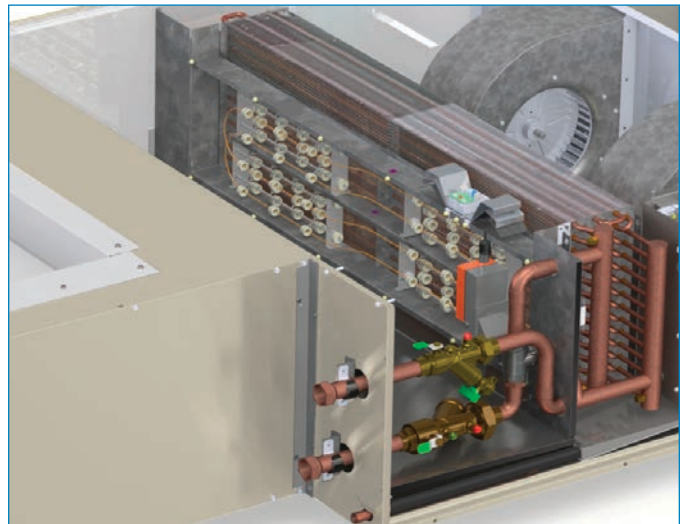
**Figure 1: Electric Heat Section (Reheat Coil Shown)**







**Figure 2: Electric Heat Section (Reheat Coil Shown)**



**Figure 3: Electric Heat Section (Preheat Coil Shown)**










Shutoff and Ball Valves			
<p>Shut-off Valve w/Y-Strainer</p> 	<p>Autoflow Shut-off Valve w/Strainer</p> 	<p>Shut-off Ball Valve</p> 	<p>Manual Circuit Setter</p> 

The deluxe factory installed piping package includes a fully modulating 0-10VDC or 24V ON/OFF control valve (2-way/3-way), a water strainer with blowout, P/T ports, unions, shut-off isolation valves, and an auto-flow circuit setter. This control scheme matched with a fully modulating fan allows for maximum space comfort and energy efficiency.

All piping packages are installed with Belimo control valves, Nexus automatic and manual circuit setters, Nexus strainers, and Nexus shut-offs. The control valve and circuit setter are located on the return side of the coil, (with the exception of size 006 and 008 vertical units) The strainer is located on the supply side of the coil. Several control valve types are available.

**Control Valves**

Two-Way On/Off (2-Position) Valves	Three-Way On/Off (2-Position) Valves	Two-Way Modulating Valves	Three-Way Fully Modulating Valves
<p>2-Way, 0.50FPT, On/Off, 24V, NO</p> 	<p>3-Way, 0.75FPT, 24Cv, On/Off, 24V, NC</p> 	<p>2-Way, 0.50FPT, 16Cv, Modulating, 0-10VDC</p> 	<p>3-Way, 0.50FPT, 16Cv, Modulating, 0-10VDC</p> 
<p>2-Way, 0.75FPT, On/Off, 24V, NC</p> 	<p>3-Way, .050FPT, On/Off, 24V, *Adjustable to NO or NC</p> 	<p>Two-way modulating valves allow for finely-tuned water flow which improves space comfort control as well as energy management. Modulating valves respond to a 0-10VDC signal from your thermostat or terminal controller. The valve body operates as an equal-percentage flow type. A method of relieving pump head pressure should be employed when selecting two-way valves.</p>	<p>Three-way modulating valves allow for finely-tuned water flow which improves space comfort control as well as energy management. Modulating valves respond to a 0-10VDC signal from your thermostat or terminal controller. The valve body operates as an equal-percentage flow type. A method of relieving pump head pressure should be employed when selecting three-way valves.</p>
<p>2-Way, 0.50FPT, On/Off, 24V, *Adjustable to NO or NC</p> 	<p>These valves will either be in a fully OPEN or fully CLOSED state in response to a 24 VAC signal from the controller. Normally Closed or Normally Open are available, both are of spring-return type. Three way valves are of the mixing type.</p>	<p><b>Selecting Correct Valve Characteristics</b> Daikin Applied Select Tools is automatically configured to match the valve body size to the selected coil. Valve Cv can be automatically selected based on the pressure drop through the coil and required GPM or user selected for more versatility.</p>	

These valves will either be in a fully OPEN or fully CLOSED state in response to a 24 VAC signal from the controller. Normally Closed or Normally Open are available, both are of spring-return type. A method of relieving pump head pressure should be employed when selecting two-way valves.

Belimo ZoneTight Valves (Size 006 and 008 vertical units) can be field-adjusted to be normally open or normally closed. By adjusting the manual clip, Cv values for the valve can be altered.

Size	Valve Model	Clip Position for Cv Adjustment (2-Way Valves)							
		1	2	3	4	5	6	N	No Clip
1/2"	Z2050Q-J	0.5	0.7	1.2	1.7	2.4	3.4	4.8	5.9



## Filter Options for Horizontal Units

Tool-less filter access on all sizes of the main unit can be ordered as side, bottom or top removal, (right or left hand). Top and bottom filter access is available on horizontal units through an easily removed sliding plate. AVD units come with side, top, or internal access to the filter. Side filter access is through the slotted end plate that removes easily from tabs along the filter frame. Units with the optional mix box have hinged access doors with tool-less 1/4-turn door latch(es) and can be ordered as side filter access (right or left hand) or bottom access (horizontal only; not available with bottom return). Filter racks are factory configurable to accept 4", 2" or 2" + 2" filter options. Merv 4, Merv 8, and Merv 13 rated filters are available from the factory. Daikin Applied's PreciseLine air handler comes standard with a 2" Merv 4 filter to prevent construction dust and debris from entering the unit upon startup, installation, and storage.

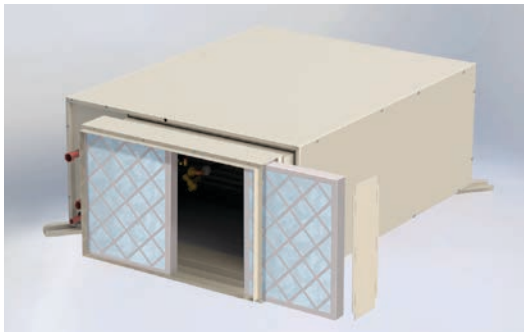
Merv Rating	Filter Depth	
	2"	4"
4	Available	–
8	Available	Available
13	Available	Available

For filter details refer to, [Table 19 on page 34](#).

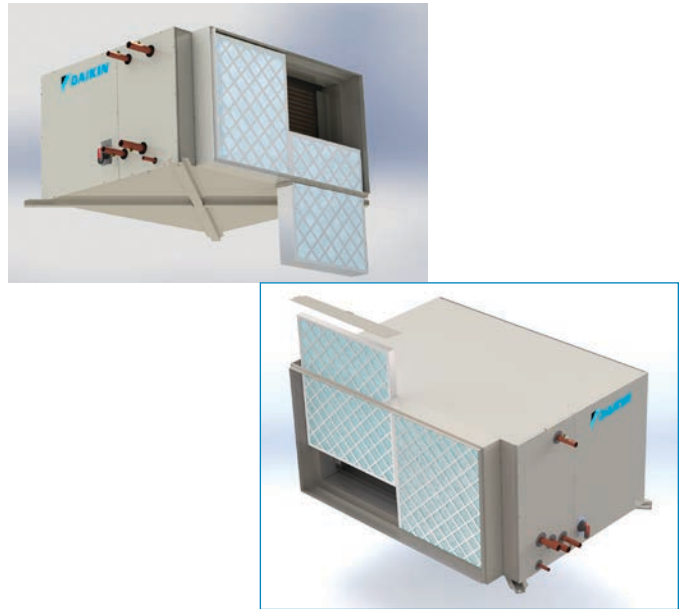
**Figure 4: Unit Size 020 Bottom or Top Filter Access**



**Figure 5: Unit Size 020 Side Filter Access**



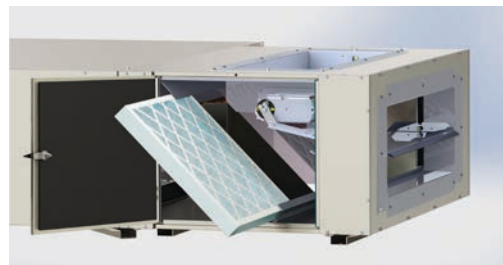
**Figure 6: Unit Size 040 Bottom or Top Filter Access**



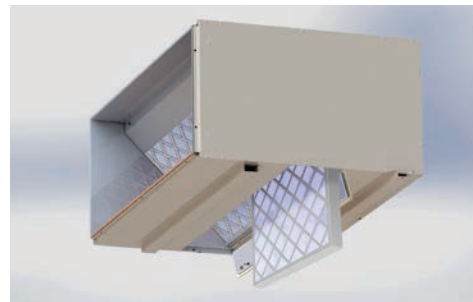
**Figure 7: Unit Size 040 Side Filter Access**



**Figure 8: Unit Size 020 Optional Mixing Box with Side Filter Access**



**Figure 9: Optional Mixing Box Bottom Filter Access**



## Filter Options for Vertical Units

Note: If the unit has an internal filter and has its inlet ducted, the ducting will need to be removed to access the filter.

Tool-less filter access on all sizes of the main unit can be ordered as side, bottom or top removal, (right or left hand). Top and bottom filter access is available on horizontal units through an easily removed sliding plate. AVD units come with side, top, or internal access to the filter. Side filter access is through the slotted end plate that removes easily from tabs along the filter frame. Units with the optional mix box have hinged access doors with tool-less 1/4-turn door latch(es) and can be ordered as side filter access (right or left hand) or bottom access (horizontal only; not available with bottom return). Filter racks are factory configurable to accept 4", 2" or 2" + 2" filter options. Merv 4, Merv 8, and Merv 13 rated filters are available from the factory. Daikin Applied's PreciseLine air handler comes standard with a 2" Merv 4 filter to prevent construction dust and debris from entering the unit upon startup, installation, and storage.

Merv Rating	Filter Depth	
	2"	4"
4	Available	—
8	Available	Available
13	Available	Available

For filter details refer to, [Table 20 on page 34](#).

**Figure 10: Unit Sizes 006 - 020 External Filter Removal on Left Side**



**Figure 11: Unit Sizes 006 - 020 External Filter Removal on Right Side**



**Figure 12: Unit Sizes 006 - 020 Internal Filter Removal**



**Figure 13: Sizes 030 - 050 Filter Access**



**Figure 14: Sizes 030 - 050 Side Filter Access**



**Figure 16: Sizes 060-100 Pre-Filter Removal**



**Figure 15: Sizes 060-100 Post / Discharge Filter Access**





# Application Considerations

## MicroTech 4 Lite Factory-Integrated Controller



The factory-integrated controller simplifies startup and reduces controls complexity by utilizing proven factory controls schemes.

- Provides standalone or BAS integrated air handler control.
- Comprehensive unit control and status information is available to the BAS via BACnet MS/TP.
- Easy monitoring and troubleshooting via the integrated thermostat, BAS, or portable interface.

### Controller Accessories Available

Controller Accessory	Installation Method	Function Affected
Damper Actuator	Factory	Damper
Freezestat	Factory	Alarm Only
Condensate Overflow Switch	Factory	Cool / Dehumidification
Outdoor Temp and Humidity Combo Sensor	Field	Economizer
Outdoor Temperature Only Sensor	Field	Economizer
Room Sensor	Field	Temp & Setpoints
Space Humidity Sensor	Field	Dehumidification / Economizer
Airflow Status	Field	Alarm Only
Discharge Air Temperature Sensor	Field	Cool / Heat / Reheat
Leaving Coil Temperature Sensor	Field	Dehumidification
Duct Static Pressure Sensor	Field	Fan Speed
Entering Water Temperature Sensor (2-Pipe)	Field	Cool / Heat

## Controller Components

### Portable Interface



The portable interface connects to units via a factory-mounted RJ45 cable to an external cabinet connection port, providing convenient access for diagnostics and controls adjustments.

Each portable interface offers the following functionalities:

- Push-and-roll navigation wheel with an 8-line by 30-character display format
- Digital display of messages in English language
- All operating conditions, system alarms, control parameters and schedules are monitored

### Integrated Thermostat



The integrated thermostat allows occupants to manage unit functions, including:

- Scheduling and setting temporary cooling/heating set points
- Adjusting fan speed for constant volume units
- Request temporary set points

## Controller Functions

### Fan Speed Control

Supply fan control to meet your building needs.

#### Supply Fan Control Methods

- Constant volume
- Duct static pressure
- Single-zone VAV

### Cooling and Heating Control

Ensure comfort and efficiency by selecting the preferred mode control and modulation that fits your application.

#### Hydronic Systems (2-pipe changeover or 4-pipe)

- Normally Open/Closed 24 VAC or 0-10 VDC modulation
- Entering water sampling (2-pipe changeover only)
  - For changeover configurations, verify entering water temperature is within range for cooling / heating request.

#### Electric Heat

- Staged or SCR modulation

### Dehumidification Control

Preciseline units with factory-integrated controllers offer two strategies for space dehumidification.

#### Strategy 1: Active Dehumidification

Active dehumidification adds a reheat component to achieve desired discharge air temperatures. After the supply air is dehumidified through the primary cooling coil, it then passes through a reheat component to deliver comfortable, dehumidified air to the space.

#### Strategy 2: Passive Dehumidification (low fan speed)

Passive dehumidification is available when a reheat component is not available to operate simultaneously with the cooling coil. The supply fan will slow down to further dehumidify the air stream while still meeting the space cooling set point.

### Economizer Control

The economizer control is available in multiple strategies to meet your space's needs, including:

- Outdoor Dry Bulb
- Outdoor Enthalpy
- Comparative Dry Bulb
- Comparative Enthalpy
- Demand-controlled ventilation

### Scheduling

- 7 daily schedules
- 1 holiday schedule (up to 10 days per year)
- Automatically run holiday schedule on set holiday dates
- Network schedule control available when BAS integrated

### Split DX / Compressor Control

All units with factory-integrated controllers are capable of automatic compressor, lead-lag control. Lead-lag control is available based on selectable compressor run-time or compressor starts. If automatic control is not desired, the operator can assign fixed lead and lag designations to the compressor circuits.

### Timed Occupant Override

When non-scheduled unit operation is desired, initiate timed occupant override by pressing the occupant override button on the integrated thermostat. The unit then starts and runs in override mode for an adjustable length of time (up to five hours). If the button is pressed again while the unit is operating, the timer resets to the full time allowance without interrupting unit operation. Override operation also can be initiated by a BAS.

### Auto/Manual Operation Selection

From the integrated thermostat keypad, there are a variety of occupancy and auto/manual control mode selections available to the operator:

Occupancy Modes	Control Modes
Occupied	Off manual
Unoccupied	Auto
Bypass (occupant override)	Heat
Standby	Cool
	Fan Only

### Additional Features and End Devices

#### Run-time Monitoring

- Fan run-time
- Dirty filter notification based on run-time or a field-installed differential pressure switch
- Compressor start count or run-time recording

#### Startup System Check (Portable Interface Only)

Verify unit operation with two available startup overrides:

- *Operational Override* - temporarily place the unit in maximum heating or cooling mode
- *Output Override* - temporarily command specific components to operate

#### Alarm History

Controller records 30 most recent alarms to help determine patterns and aid troubleshooting.

#### Duct Static Pressure Control

Duct static pressure control is maintained by a PI algorithm, which provides precise control of the supply fan. The integrated thermostat keypad programmable set point can be set between 0.20-in. W.C. and 4.00-in. W.C.

#### Internal Time Clock

An internal, battery-backed time clock is included. Current date and time can be quickly and easily set at the portable interface.

## Digital-Ready Features (for field-installed controllers)

For units without a factory-integrated controller, there are digital-ready selections available for connecting to an existing BAS and controller in the field.

### Fan Speed Control

#### 0-10 VDC Analog Control

Fan modulation control allows the space temperature to be controlled by constantly adjusting the airflow rate across the coil. Increasing and decreasing the CFM across the coil in response to changes in space temperature essentially changes the capacity of the coil to match the current load for improved comfort and reduced energy consumption and unit noise. While fan modulation is typically used with on-off valve control which allows the maximum design GPM through the coil, it may also be used with a modulating control valve to provide even greater temperature control. Fan modulation control requires a controller or thermostat capable of generating and changing the 0-10 VDC signal in response to the changes in space temperature.

#### 3-Speed Discrete Control (Sizes 006-020 only)

Three speed fan control runs the fan continuously at one of three programmed speeds. These three speeds can be changed on the factory-installed speed adjustment board. This type of control requires a 24 VAC binary signal control signal applied to one of the motors speed terminals. The motor will run at the corresponding speed for as long as the signal is maintained. This type of fan control allows the unit to be controlled with 3 position fan switch or a simple fan coil type thermostat.

### Valve Control

Valve modulation controls space temperature by constantly adjusting the water flow rate through the coil to modulate coil capacity and improve comfort.

#### 0-10 VDC Analog Control

The valve actuator responds to a 0-10 VDC input from the controller. As space demand increases and decreases, water flow rates are adjusted as well.

#### Open/Closed 24 VAC Control

The valve actuator responds to a binary 24 VAC signal. It can be configured for an "on-with-demand" (Normally Closed) or "off-with-demand" (Normally Open) control scheme. The water flow rate is designated by the auto flow valve (circuit setter).

### Electric Heat Control

Electric heat control may be binary (on-off) or modulating. With binary the full capacity of the electric heating element turns on with a 24 VAC signal from the controller and stays on until the set point is reached. Modulating control which requires a 0-10 VDC signal from the thermostat or controller uses an SCR switching module to vary the heat output of the electric element. Matching the heat output to space load increases comfort and reduces noise and energy consumption. It is the responsibility of

the controls contractor or the customer to ensure that the electric heating elements never operate without the minimum airflow as listed starting on [page 46](#). Factory provided safety limits built in to the electric heat assembly and the SCR module prevent overheating should a fan failure occur. See [Electric Heat Safety on page 36](#) for more information on the operation of the safety limits.

### Condensate Overflow

The factory installed overflow switch is a normally closed dry contact that will open when water in the primary drain pan rises to the designated level. The switch must be wired to a controller or thermostat with an appropriate alarm input that will close the cooling valve and possibly turn off the fan when the switch opens. If necessary, the normal state of the dry contact may be changed to normally open by turning the float over on the guide pin. With this change the dry contact will close when water reaches the designated level.

### Coil Freeze Protection

If entering air temperatures below 40°F is a possibility, the use of some type of freeze protection is strongly advised. Freeze protection may include adding glycol to the water in the system to prevent coil rupture or using a low temperature thermostat capillary tube mounted on the inlet side of the primary or preheat coil. If glycol is used, the type and amount of glycol should be determined by the application requirements and must be accounted for in the coil performance calculations. A low temperature thermostat capillary tube should be connected to a controller, capable of closing the outside air damper and opening the control valve to allow water flow through the coil. It should also send an alarm to the BAS or maintenance station to alert appropriate personnel.

### Damper Control

- Damper control can be factory configured for either on-off or analog control.
- On-off control requires a 24 VAC signal applied to the terminal labeled ACT 24+ to cycle the damper.
- Analog control requires a 0-10 VDC signal applied to the terminal labeled ACT 0-10V to modulate the damper.

### **Mixing Box (Optional) – Field Provided Damper Actuator**

The optional mixing box includes a fresh air and return air damper that are linked together and driven from the same actuator. It may be ordered with or without the factory mounted damper actuator. Those with the factory mounted actuator ship pre-wired to the main unit control box and do not require field adjustment of the hardware or linkage.

For the mixing box ordered without the factory mounted damper actuator one must be provided in the field that meets the following criteria.

- Maximum range of rotation = 95°
- Maximum torque = 62 in/lbs
- On-off control = spring return
- Modulating control = 0-10 VDC fail in place
- Damper shaft size = 0.5" diameter

A mounting plate is provided on the shaft side of the damper frame to accommodate a variety of actuators. However, due to the number of options, size variations, and arrangements available, some actuators may require alternate field provided mounting hardware. Proper support for the actuator is important to avoid putting excess stress on the cabinet, linkage, or damper shafts. The installing contractor is responsible for mounting, and wiring of the actuator and adjustment of the damper linkage.

### **Optional Mixing Box Damper or Discharge Plenum Loss**

For reference, losses are similar to those used in custom openings, however, their coefficients are multipliers of velocity pressure based on opening size. These are multipliers of coil velocity pressure. The intake loss assumes a fully open damper in line with the unit, based on the sudden expansion into the unit of 2× the face area and 20% drag from the blade. The discharge loss assumes the sudden expansion of the fan of 10× then a sudden contraction at the discharge of 3× the face area. Losses from a grille are not taken into account.

$$\text{Intake, intake with damper or discharge plenum loss} = \left( \frac{V \cdot C}{4005} \right)^2$$

V = velocity through the opening

- C:
- Straight intake without damper = 0.75
  - Turned intake without damper = 1.0
  - Straight intake with damper = 1.0
  - Turned intake with damper = 1.33
  - Straight discharge = 1.5
  - Turned discharge = 2

### **Example:**

For a selection at 1000 ft/min, mix box with rear intake and discharge plenum down discharge:

Intake loss is  $(1000 \cdot 1 / 4005)^2 = 0.062''$

Discharge loss is  $(1000 \cdot 1.5 / 4005)^2 = 0.140''$

## **Mounting and Access**

The air handler unit must be installed on a flat and level surface (or verify that the unit is level when hanging from the ceiling). Where surface irregularities allow the equipment to distort, shim the appropriate base rails to straighten the unit. Distorted units can cause misfit between sections, cabinet leaks, binding of the doors and access panels and prevent proper draining of drain pans.

Leave adequate space around the unit for piping, coils, and drains. Always have access to at least one side of the unit for regular service and maintenance. Refer to images on the following pages for servicing space requirements. Routine maintenance examples include filter replacement, drain pan inspection/cleaning, and motor bearing lubrication.

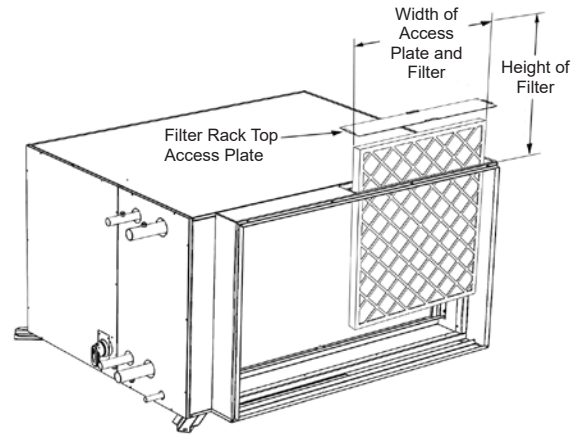
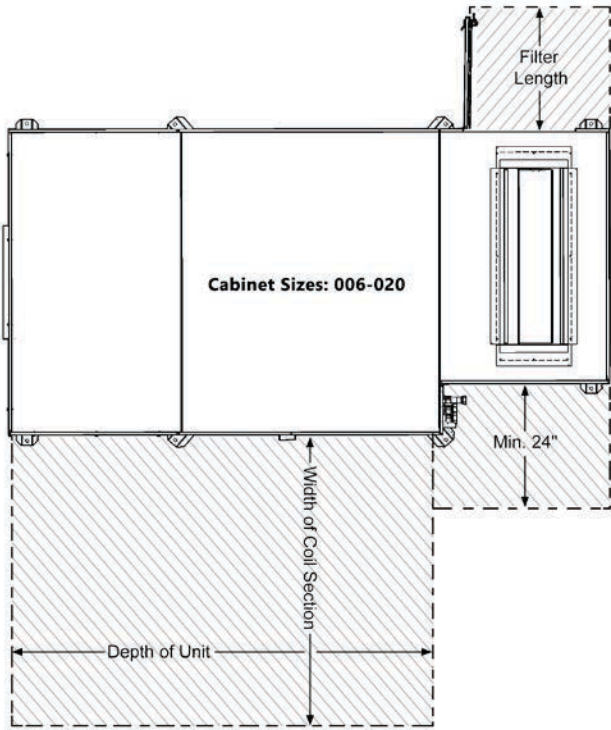
Note that compact vertical units are accessed from the front of the unit. If they are ducted, access will require removal of the duct.

Provide sufficient space on the controls access side of the unit for filter replacement, drain pan cleaning and coil removal, if necessary.

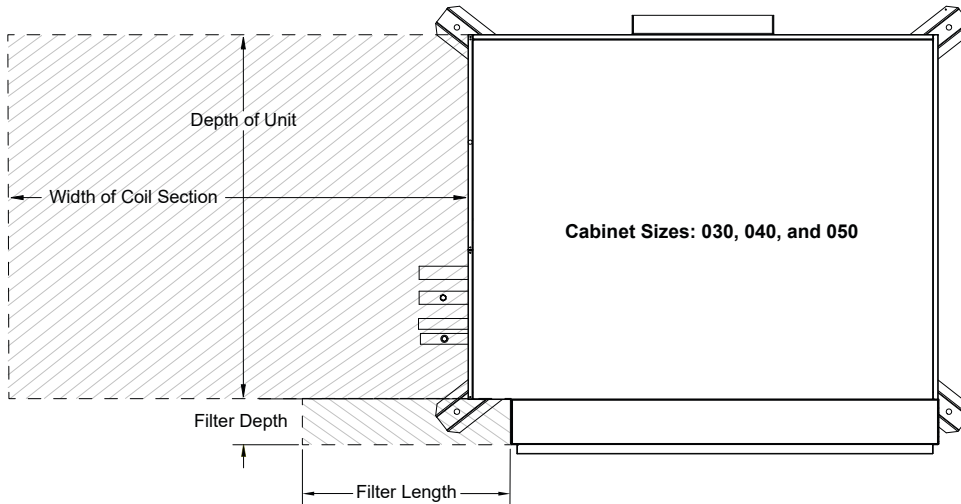
Leave at least 42" of clearance in front of electrical power devices (starters, VFDs, disconnect switches, and combination devices) mounted behind service panels.

Factory ordered spring isolators are recommended on unit sizes 030, 040 and 050.

**Figure 17: Clearance and Access Requirements for Horizontal Units (Sizes 006-050)**



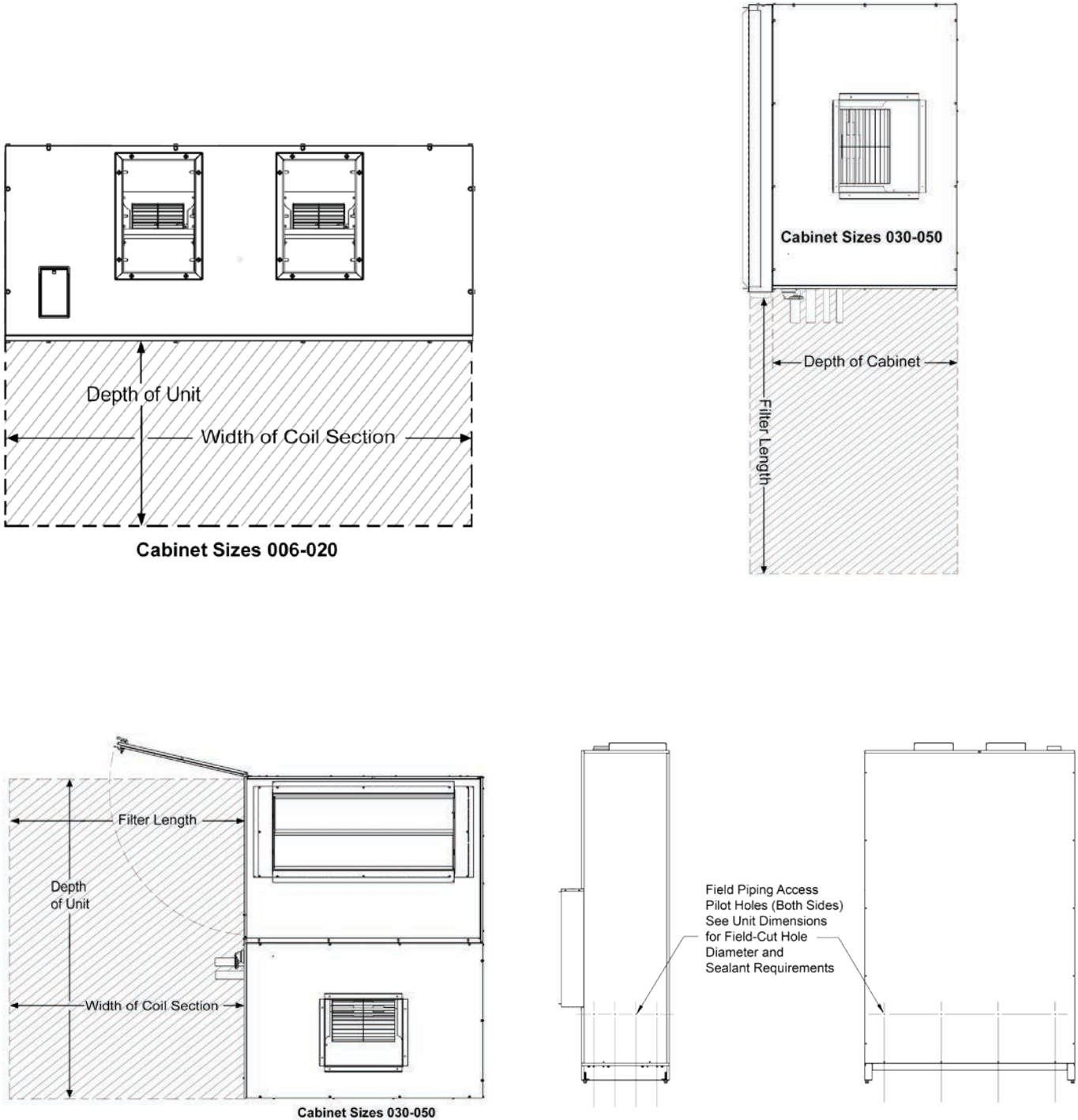
**Top Filter Access Clearance Cabinet Sizes: 030 – 050**





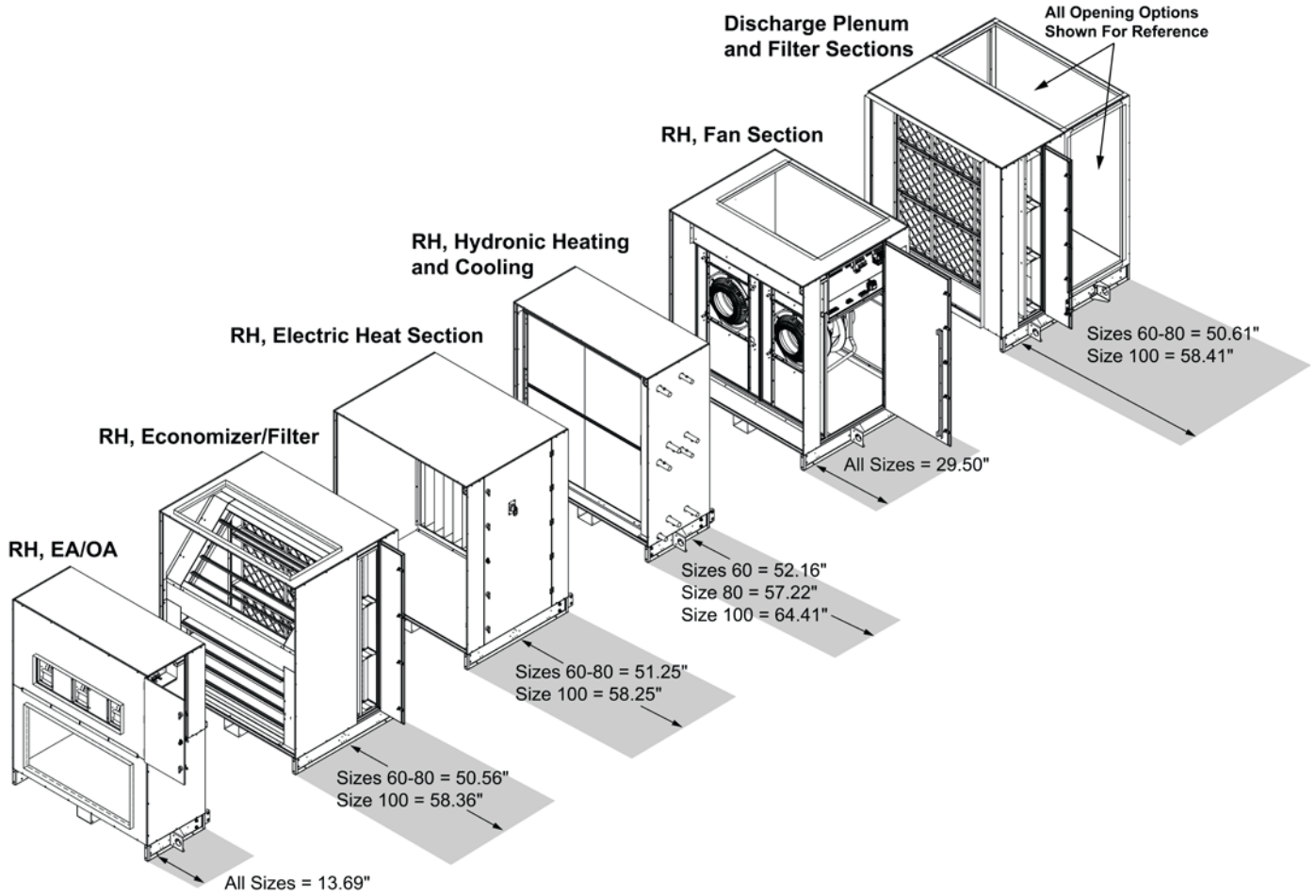
**Figure 18: Clearance and Access Requirements for Vertical Units**

Note: AVD units require field-cut holes on the sides or back, depending on piping orientation. These holes should either be drilled prior to unit installation, or a clearance of 24" should be left on the side requiring field work.



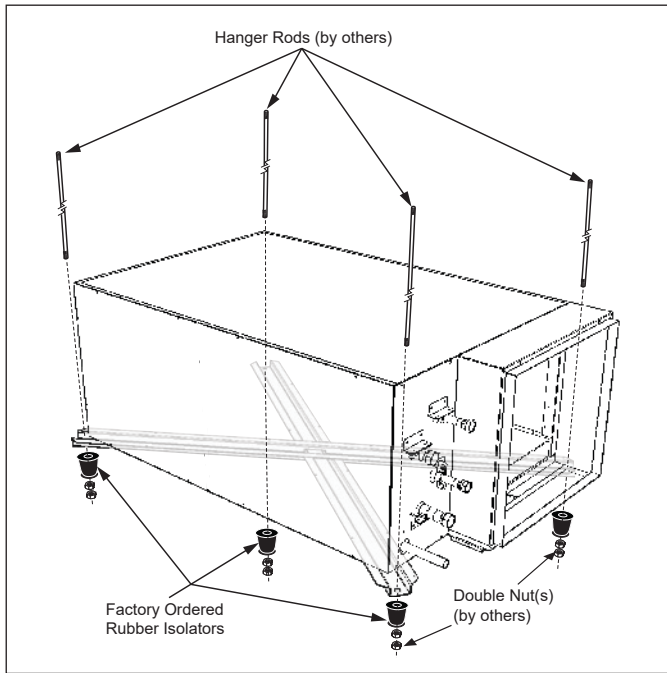


**Figure 19: Clearance and Access Requirements for Unit Sizes 060-100**



## Horizontal Unit Mounting Isolation

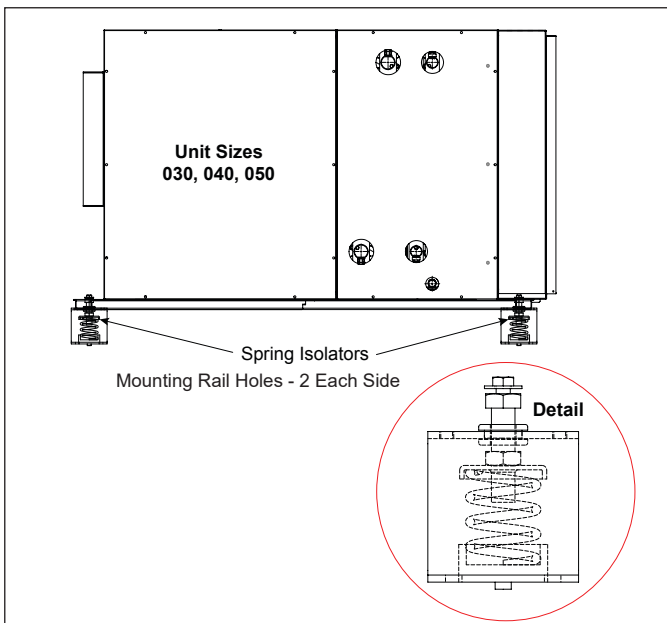
**Figure 20: Ceiling Hung with Rubber Isolators - Unit Sizes 030-050.**



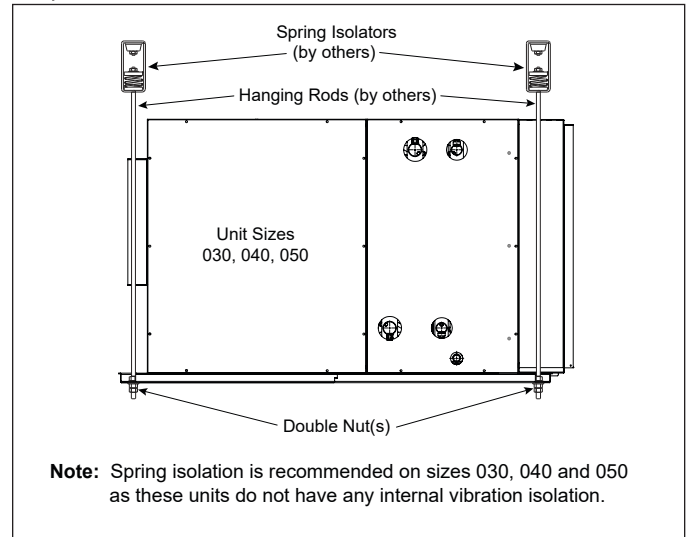
### Spring Mount—Sizes 030, 040, 050

Factory ordered spring isolators are recommended on unit sizes 030, 040 and 050. The isolators should all be at the same height opening.

**Figure 21: Floor Mounted Spring Isolation - Unit Sizes 030, 040, 050.**



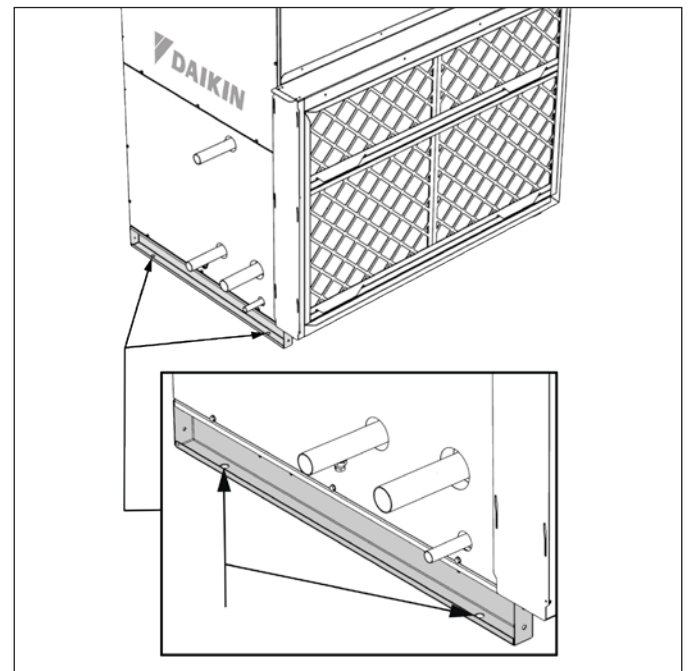
**Figure 22: Ceiling Hung Spring Isolation - Unit Sizes 030, 040, 050.**



## Vertical Unit Mounting Isolation

Neoprene pads and/or spring isolators are to be provided by others, if required.

**Figure 23: Unit Size 040 Mounting Rail Holes Detail**



## Access Panels and Doors

PreciseLine air handlers have hinged access doors or screw-on panels that can be easily removed and handled. To gain access through a side panel, remove the fasteners along the sides of the panel and lift the panel off. Allow sufficient space for service panel removal and to meet the service clearance requirement of the section it accesses. Service panels are not interchangeable with service panels on the opposite side of the unit.

Figure 24: Panel Removal

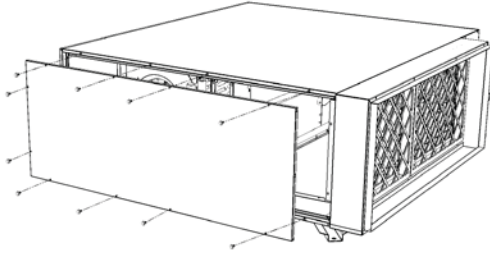


Figure 25: Filter Access Doors

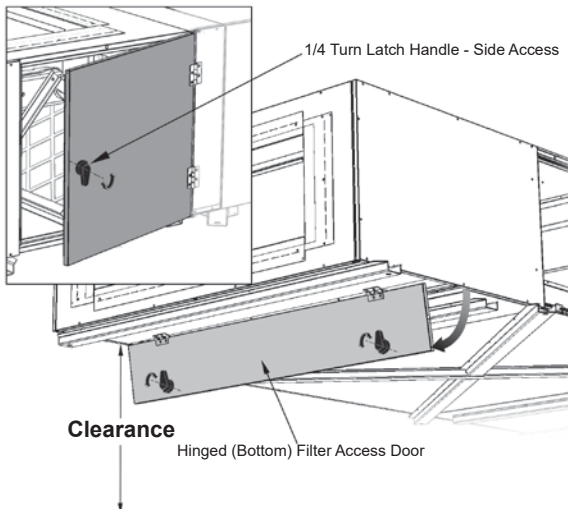
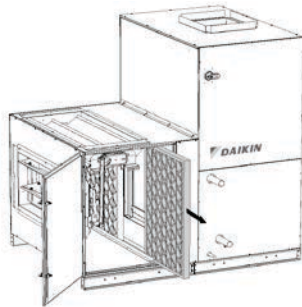


Table 1: Bottom Filter Access Clearance (inches)

Unit Size	006 – 020	030	040	050
Clearance	18.00	24.00	28.00	30.00

Figure 26: Filter Access Doors



## Piping and Coils

Follow applicable piping design, sizing, and installation information presented in ASHRAE Handbooks in the design and installation of piping. Observe all local codes and industry standards. Piping field connection locations are the same for units with and without the optional factory-installed valve package. Refer to page 26 for the connection size and type. Refer to dimensional drawings beginning on page 52 for connection locations and dimensions.

## Hydronic Coil Connections

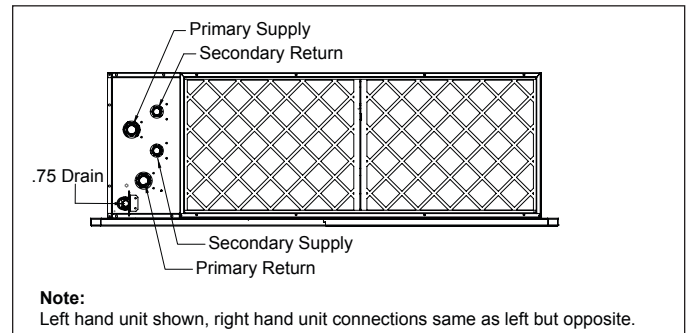
For all units Sizes 30-50; hydronic supply, return, and drain stubs extend through the end panel of the cabinet, with field connections made outside the cabinet. **All stubs are labeled on the end panel.** A "No Piping" option is available with internal coil stubs. Chilled water supply, return, and drain stubs may terminate inside or outside the cabinet on compact horizontal units, and necessarily terminate in a central location inside the cabinet on AVD units. Stub outs are labeled individually and/or on the end panel.

Hydronic supply and return connections are copper FPT on sizes 006 through 020 and copper sweat on sizes 030 through 050. Refer to page 26 for connection sizes and type.

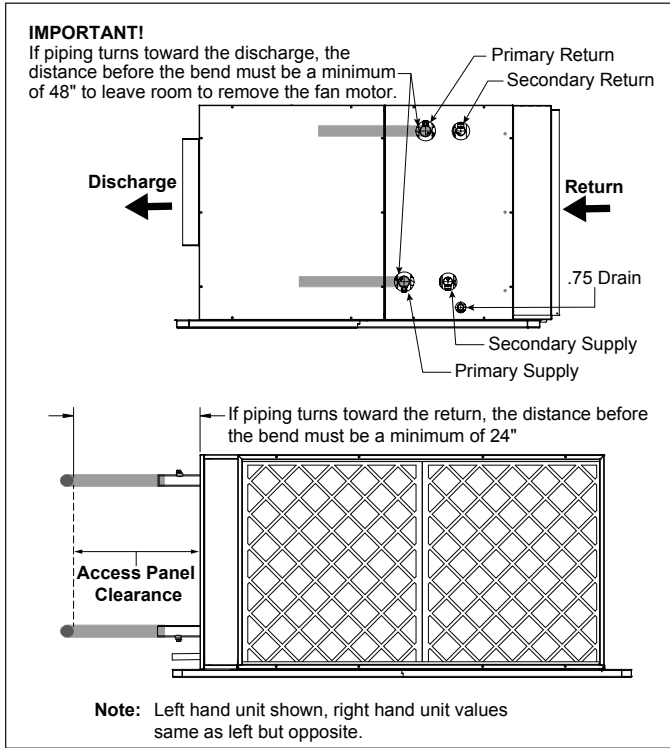
Hydronic heating coil guidelines are listed below.

1. Hot water coils are not recommended for use with entering air below 40°F.
2. If fresh air and return air are to be heated by a hot water coil, take care in the design of the system to provide thorough mixing before air enters the coil.

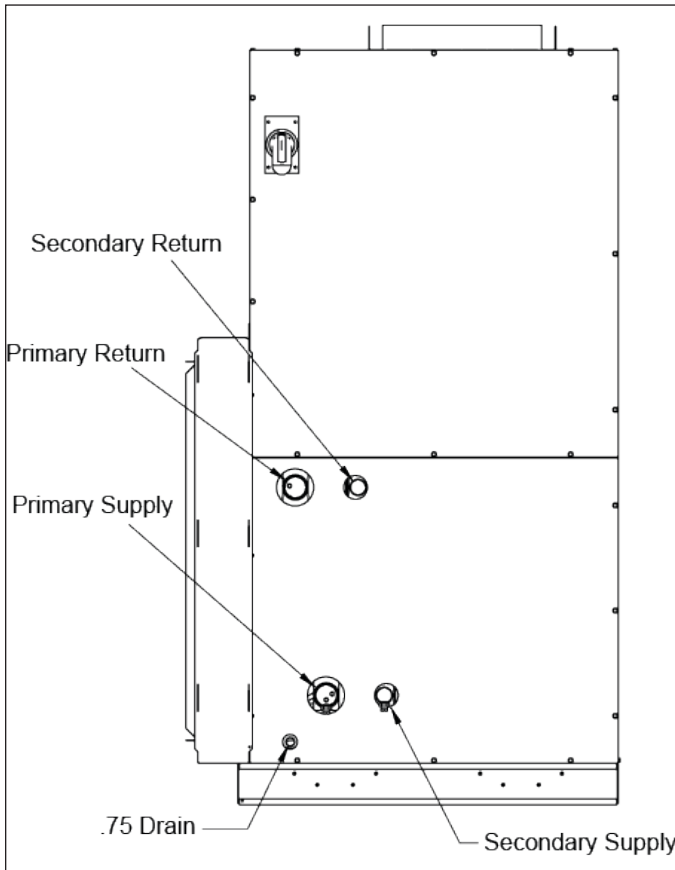
Figure 27: Coil Connections, Unit Sizes 006-020



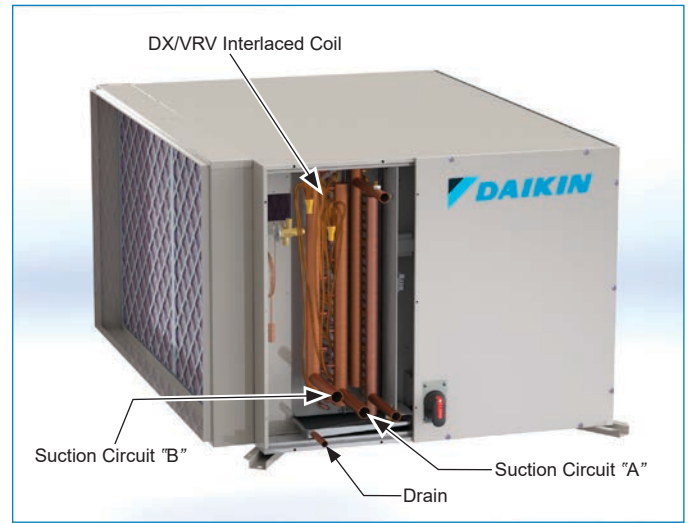
**Figure 28: Field Pipe Connections, Unit Sizes 030, 040, 050 (preheat coil option shown)**



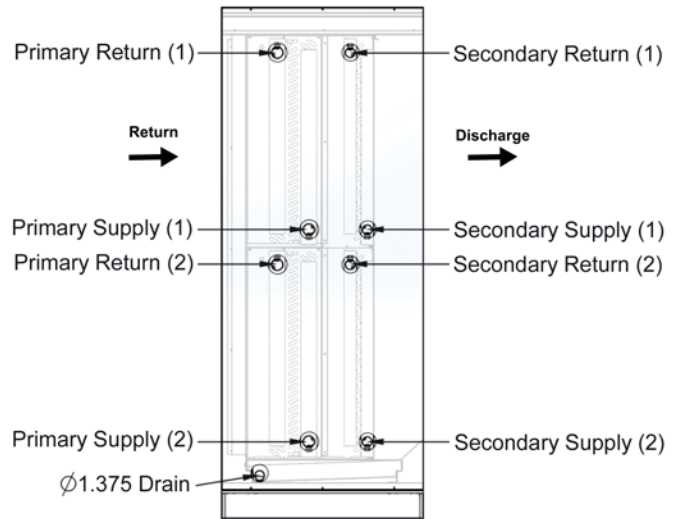
**Figure 29: Coil Connections, Unit Sizes 030 Thru 050**



**Figure 30: DX Interlaced Coil, Unit Sizes 030-050**



**Figure 31: Coil Connections, Unit Sizes 060-100**

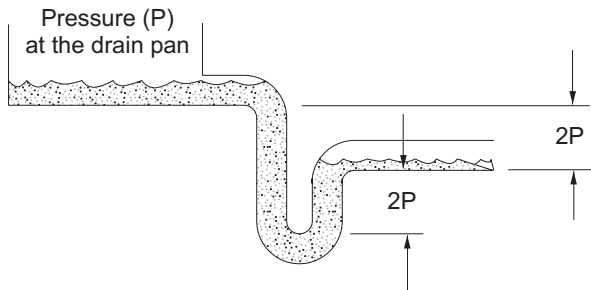


## Condensate Drain Pan Traps

Condensate drain stub is .75 O.D. for sizes 006-050 and 1.375 O.D. for sizes 060-100. Drain lines and traps should run full size from the drain pan stub. Drain pans should have traps to allow condensate from coils to drain freely. The trap depth and distance between the trap outlet and the drain pan outlet should be twice the static pressure in the drain pan section under normal operation for the trap to remain sealed. Refer to Figure 32.



**Figure 32: Allow Adequate Distance Between Trap Outlet and Drain Outlet**



# Engineering Data

## Operation Limitations

### Leaving Air Temperature

- Daikin Applied's PreciseLine is a draw thru style air handler which means the fan housing and motor assembly are in the conditioned part of the air stream. Coil leaving air temperatures over 125°F are not recommended and threaten the longevity of the unit.

### Entering Air Temperatures

- The coils used in PreciseLine are not suitable for exposure to freezing temperatures. Proper consideration must be taken to keep the air temperature seen by the coil above the freezing point of the coil's working fluid. Units with a mixing box must be especially careful because large temperature differences between return air and outdoor air can leave the coil vulnerable through air stratification.

### Entering Water Temperatures

- Entering water temperatures above 200°F are not recommended as PreciseLine's coils are tested and rated to 200°F in accordance with UL 1995.

### Voltage Variance

- To preserve longevity of electrical components supplied voltage must be within 10% of the nominal nameplate voltage.

**Table 2: Horizontal Hydronic Coil Size and Connection Type**

Unit Size	006	008	010	012	016	018	020	030	040	050	060	080	100
<b>Connection Type</b>	FPT (Nominal)					F-SWT (OD)							
2-Row Cooling	0.500	0.500	0.500	0.500	0.750	0.750	0.750	1.125	1.125	1.375	1.125	1.125	1.375
4-Row Cooling	0.500	0.500	0.750	0.750	0.750	1.000	1.000	1.375	1.625	1.625	1.375	1.625	1.625
6-Row Cooling	0.500	0.500	0.750	0.750	1.000	1.000	1.000	1.375	1.625	1.625	1.375	1.625	1.625
8-Row Cooling	—	—	—	—	—	—	—	1.375	1.625	1.625	1.375	1.625	1.625
1-Row Heating	0.500	0.500	0.500	0.500	0.500	0.500	0.500	0.625	0.875	1.125	0.625	0.875	1.125
2-Row Heating	0.500	0.500	0.500	0.500	0.750	0.750	0.750	1.125	1.125	1.375	1.125	1.125	1.375

Note: number of connections in unit sizes 060-100 are doubled (stacked)

**Table 3: Vertical Hydronic Coil Size and Connection Type**

Unit Size	006	008	012	016	020	030	040	050
<b>Connection Type</b>	FPT (Nominal)				F-SWT (OD)			
2-Row Cooling	0.500	0.500	0.500	0.750	0.750	1.125	1.375	1.375
4-Row Cooling	0.500	0.500	0.750	0.750	1.000	1.375	1.625	1.625
6-Row Cooling	0.500	0.500	0.750	1.000	1.000	1.625	1.625	2.125
8-Row Cooling	—	—	—	—	—	1.625	2.125	2.125
1-Row Heating	0.500	0.500	0.500	0.500	0.500	0.625	0.875	1.125
2-Row Heating	0.500	0.500	0.500	0.750	0.750	1.125	1.375	1.375

**Table 4: Hydronic Coil Size and Type with No Piping Option**

Unit Size	006	008	012	016	020
<b>Connection Type</b>	M-SWT (OD)				
2-Row Cooling	0.625	0.625	0.625	0.875	0.875
4-Row Cooling	0.625	0.625	0.875	0.875	1.125
6-Row Cooling	0.625	0.875	0.875	1.125	1.125
8-Row Cooling	—	—	—	—	—
1-Row Heating	0.625	0.625	0.625	0.625	0.625
2-Row Heating	0.625	0.625	0.625	0.875	0.875



**Table 5: Vertical Steam Coil Size and Type**

Unit Size	006	008	012	016	020	030	040	050
Connection Type	M-SWT (OD)							
Supply	1.125	1.125	1.125	1.125	1.125	1.125	1.125	1.375
Return	0.875	0.875	0.875	0.875	0.875	1.125	1.125	1.375

**Table 6: Horizontal Steam Coil Size and Type with Piping**

Unit Size	006	008	010	012	016	018	020	030	040	050	060	080	100
Connection Type	FPT (Nominal)							M-SWT (OD)					
Supply	0.750	0.750	0.750	0.750	0.750	0.750	0.750	1.125	1.125	1.375	1.125	1.125	1.375
Return	0.500	0.500	0.500	0.500	0.500	0.500	0.500	1.125	1.125	1.375	1.125	1.125	1.375

Note: number of connections in unit sizes 060-100 are doubled (stacked)

**Table 7: Horizontal Steam Coil Size and Type with No Piping**

Unit Size	006	008	010	012	016	018	020
Connection Type	FPT (Nominal)						
Supply	0.750	0.750	0.750	0.750	0.750	0.750	0.750
Return	0.500	0.500	0.500	0.500	0.500	0.500	0.500
Coil Size							
Finned Height	12	12	12	12	12	12	12
Finned Length	6.5	10.5	19	19	27	35.5	35.5

Note: FPI of 10 may be selected.

**Table 8: VRV Coil Size and Type**

Unit Size	Rows	Fin Height	Fin Length	FPI	Connection Size (M-SWT (OD))	
					Distributor	Suction
006	3	14	12.5	12	0.375	0.750
008	3	14	16.5	12	0.375	0.750
010	3	14	25	12	0.375	0.875
012	3	14	25	12	0.375	0.875
016	3	14	33	12	0.375	1.125
018	3	14	41.5	12	0.375	1.125
020	3	14	41.5	12	0.375	1.125
030	3	22	39.5	10	0.500	1.375
040	3	26	44.5	12	0.625	1.375
050	3	28	51.5	12	0.625	1.625
060	3	44*	39.5	10	0.5	1.375
080	3	52*	44.5	12	0.625	1.375
100	3	56*	51.5	12	0.625	1.625

Note: number of connections in unit sizes 060-100 are doubled (stacked)

\*Combined height of two vertically stacked coils

**Table 9: DX Coil Size and Type**

Unit Size	Rows	Circuits		Connection Size (M-SWT (OD))	
		Number	Type	Distributor	Suction
006	3	1	Normal	0.500	0.750
006	6	1	Normal	0.500	0.750
008	3	1	Normal	0.500	0.875
008	6	1	Normal	0.500	0.875
012	3	1	Normal	0.500	1.125
012	6	1	Normal	0.625	1.125
016	3	1	Normal	0.625	1.125
016	6	1	Normal	0.875	1.125
020	3	1	Normal	0.875	1.375
020	6	1	Normal	0.875	1.375
030	3	1	Normal	0.875	1.625
030	3	2	Interlaced	0.625	0.875
030	6	1	Normal	—	—
030	6	2	Interlaced	0.875	0.875
040	3	1	Normal	0.875	1.625
040	3	2	Interlaced	0.875	1.125
040	6	1	Normal	—	—
040	6	2	Interlaced	0.875	1.375
050	3	1	Normal	0.875	1.625
050	3	2	Interlaced	0.875	1.375
050	6	1	Normal	—	—
050	6	2	Interlaced	0.875	1.625
060	3	2	Normal	0.875	1.625
060	3	4	Interlaced	0.625	0.875
080	3	2	Normal	0.875	1.625
080	3	4	Interlaced	0.875	1.125
100	3	2	Normal	0.875	1.625
100	3	4	Interlaced	0.875	1.375

Note: FPI of 12, 14, or 16 may be selected. Number of connections in unit sizes 060-100 are doubled (stacked).

# Physical Data

## Component Weights

**Table 10: Horizontal Component Weights (sizes 006-050)**

Component	Rows	FPI	Weight — lbs (kg)									
			006	008	010	012	016	018	020	030	040	050
Coil (Wet)	1	12	6 (3)	7 (4)	9 (5)	9 (5)	10 (5)	11 (5)	11 (5)	20 (10)	26 (12)	33 (15)
Coil (Wet)	1	16	7 (4)	7 (4)	9 (5)	9 (5)	11 (5)	12 (6)	12 (6)	21 (10)	28 (13)	35 (16)
Coil (Wet)	2	12	9 (5)	10 (5)	13 (6)	13 (6)	17 (8)	19 (9)	19 (9)	33 (15)	43 (20)	53 (25)
Coil (Wet)	2	16	9 (5)	11 (5)	14 (7)	14 (7)	18 (9)	21 (10)	21 (10)	36 (17)	46 (21)	57 (26)
Coil (Wet)	4	12	13 (6)	16 (8)	23 (11)	23 (11)	28(13)	35 (16)	35 (16)	57 (26)	77 (35)	93 (43)
Coil (Wet)	4	16	14 (7)	17 (8)	24 (11)	24 (11)	30 (14)	38 (18)	38 (18)	61 (28)	84 (39)	101 (46)
Coil (Wet)	6	12	18 (9)	23 (11)	31 (15)	31 (15)	41 (19)	49 (23)	49 (23)	78 (36)	106 (49)	128 (59)
Coil (Wet)	6	16	19 (9)	25 (12)	34 (16)	34 (16)	44 (20)	54 (25)	54 (25)	85 (39)	115 (53)	140 (64)
Coil (Wet)	8	12	-	-	-	-	-	-	-	100 (46)	134 (61)	164 (75)
Coil (Wet)	8	16	-	-	-	-	-	-	-	109 (50)	147 (67)	179 (82)
Coil (Dry)	1	12	5 (3)	6 (3)	7 (4)	7 (4)	8 (4)	9(5)	9(5)	16 (8)	20 (10)	25 (12)
Coil (Dry)	1	16	5 (3)	6 (3)	7 (4)	7 (4)	8 (4)	10 (5)	10 (5)	17 (8)	22 (10)	27 (13)
Coil (Dry)	2	12	7 (4)	8 (4)	10 (5)	10 (5)	12 (6)	14 (7)	14 (7)	24 (11)	32 (15)	39 (18)
Coil (Dry)	2	16	7 (4)	8 (4)	11 (5)	11 (5)	14 (7)	16 (8)	16 (8)	27 (13)	35 (16)	43 (20)
Coil (Dry)	4	12	10 (5)	12 (6)	16 (8)	16 (8)	20 (10)	25 (12)	25 (12)	41 (19)	55 (25)	65 (30)
Coil (Dry)	4	16	11 (5)	13 (6)	18 (9)	18 (9)	23 (11)	28 (13)	28 (13)	46 (21)	61 (28)	73 (34)
Coil (Dry)	6	12	13 (6)	16 (8)	23 (11)	23 (11)	29 (14)	35 (16)	35 (16)	56 (26)	75 (35)	91 (42)
Coil (Dry)	6	16	14 (7)	18 (9)	25 (12)	25 (12)	33 (15)	40 (19)	40 (19)	63 (29)	84 (39)	102 (47)
Coil (Dry)	8	12	-	-	-	-	-	-	-	72 (33)	95 (44)	116 (53)
Coil (Dry)	8	16	-	-	-	-	-	-	-	81 (37)	107 (49)	131 (60)
DX Normal	3	12	9(5)	11 (5)	15 (7)	15 (7)	19 (9)	23 (11)	23 (11)	38 (18)	49 (23)	60 (28)
DX Interlaced	3	12	-	-	-	-	-	-	-	36 (17)	47 (22)	58 (27)
DX Normal	3	16	10 (5)	12 (6)	17 (8)	17 (8)	21 (10)	25 (12)	25 (12)	42 (20)	54 (25)	66 (30)
DX Interlaced	3	16	-	-	-	-	-	-	-	40 (19)	52 (24)	64 (30)
Standard Cabinet (FC Fans)	-	-	180 (82)	260 (118)	324 (147)	324 (147)	440 (200)	530 (241)	530 (241)	490 (223)	585 (266)	730 (332)
Standard Cabinet (Plenum Fans)	-	-	-	-	-	-	-	-	-	457 (208)	618 (281)	743 (338)
Mixing Box	-	-	22 (10)	32 (15)	40 (18)	40 (18)	54 (25)	54 (25)	65 (30)	68 (31)	72 (33)	90 (41)
Discharge Plenum	-	-	20 (9)	29 (13)	36 (16)	36 (16)	49 (22)	49 (22)	59 (27)	63 (29)	67 (30)	81 (37)
Primary Valve Package	-	-	6 (3)	6 (3)	9 (4)	9 (4)	10 (5)	12 (5)	12 (5)	-	-	-
Heating Valve Package	-	-	4 (2)	4 (2)	6 (3)	6 (3)	6 (3)	8 (4)	8 (4)	-	-	-
VRV	3	12	9 (5)	11 (5)	15 (7)	15 (7)	18 (9)	22(10)	22 (10)	-	47 (22)	58 (27)
VRV	3	10	-	-	-	-	-	-	-	36 (16)	-	-

**Table 11: Horizontal Component Weights (Sizes 060-100)**

Component	Rows	FPI	Weight — lbs (kg)		
			060	080	100
Coil (Wet)	1	12	40 (18)	52 (24)	66 (30)
Coil (Wet)	1	16	42 (19)	56 (25)	70 (32)
Coil (Wet)	2	12	66 (30)	86 (39)	106 (48)
Coil (Wet)	2	16	72 (33)	92 (42)	114 (52)
Coil (Wet)	4	12	114 (52)	154 (70)	186 (84)
Coil (Wet)	4	16	122 (55)	168 (76)	20 (9)
Coil (Wet)	6	12	156 (71)	20 (9)	24 (11)
Coil (Wet)	6	16	170 (77)	22 (10)	28 (13)
Coil (Wet)	8	12	20 (9)	26 (12)	32 (15)
Coil (Wet)	8	16	20 (9)	28 (13)	34 (15)
Coil (Dry)	1	12	32 (15)	40 (18)	50 (23)
Coil (Dry)	1	16	34 (15)	44 (20)	54 (24)
Coil (Dry)	2	12	48 (22)	64 (29)	78 (35)
Coil (Dry)	2	16	54 (24)	70 (32)	86 (39)
Coil (Dry)	4	12	82 (37)	110 (50)	130 (59)
Coil (Dry)	4	16	92 (42)	122 (55)	146 (66)
Coil (Dry)	6	12	112 (51)	150 (68)	182 (83)
Coil (Dry)	6	16	126 (57)	168 (76)	20 (9)
Coil (Dry)	8	12	144 (65)	190 (86)	22 (10)
Coil (Dry)	8	16	162 (73)	20 (9)	26 (12)
DX Normal	3	12	76 (34)	98 (44)	120 (54)
DX Interlaced	3	12	72 (33)	94 (43)	116 (53)
DX Normal	3	16	84 (38)	108 (49)	132 (60)
DX Interlaced	3	16	80 (36)	104 (47)	128 (58)
VRV	3	12	-	94 (43)	116 (53)
VRV	3	10	72 (33)	-	-
Discharge Plenum	-	-	239 (108)	250 (113)	270 (122)
Discharge Plenum W/ Post Filter	-	-	307 (139)	352 (160)	378 (171)
Fan Section	-	-	422 (191)	415 (188)	457 (207)
Single Supply Fan Weight	-	-	110 (50)	110 (50)	110 (50)
Dual Supply Fan Weight	-	-	220 (100)	220 (100)	220 (100)
Coil Section	-	-	130 (59)	140 (64)	166 (75)
Prefilter	-	-	234 (106)	263 (119)	267 (121)
Mixbox	-	-	380 (172)	439 (199)	460 (209)
Economizer	-	-	406 (184)	454 (206)	479 (217)
Electric Heat	-	-	329 (149)	332 (151)	362 (164)
Exhaust Air/Outdoor Air	-	-	333 (151)	377 (171)	422 (191)

**Table 12: Vertical Component Weights**

Component	Rows	FPI	Weight—lbs (kg)							
			006	008	012	016	020	030	040	050
Coil (Wet)	1	12	6 (3)	8 (4)	9 (5)	12 (6)	13 (6)	22 (10)	28 (13)	38 (18)
Coil (Wet)	1	14	7 (4)	8 (4)	10 (5)	12 (6)	13 (6)	22 (10)	29 (14)	39 (18)
Coil (Wet)	1	16	7 (4)	8 (4)	10 (5)	12 (6)	14 (7)	23 (11)	30 (14)	40 (19)
Coil (Wet)	2	12	10 (5)	11 (5)	14 (7)	19 (9)	21 (10)	36 (17)	47 (22)	59 (27)
Coil (Wet)	2	14	10 (5)	11 (5)	14 (7)	19 (9)	22 (10)	37 (17)	48 (22)	61 (28)
Coil (Wet)	2	16	10 (5)	11 (5)	15 (7)	20 (10)	23 (11)	39 (18)	50 (23)	63 (29)
Coil (Wet)	4	12	13 (6)	17 (8)	23 (11)	30 (14)	37 (17)	61 (28)	80 (37)	101 (46)
Coil (Wet)	4	14	14 (7)	17 (8)	24 (11)	32 (15)	39 (18)	63 (29)	83 (38)	105 (48)
Coil (Wet)	4	16	14 (7)	18 (9)	25 (12)	33 (15)	40 (19)	65 (30)	86 (40)	109 (50)
Coil (Wet)	6	12	18 (9)	23 (11)	32 (15)	44 (20)	52 (24)	87 (40)	109 (50)	138 (63)
Coil (Wet)	6	14	18 (9)	24 (11)	33 (15)	45 (21)	54 (25)	90 (41)	113 (52)	143 (65)
Coil (Wet)	6	16	19 (9)	25 (12)	34 (16)	47 (22)	56 (26)	94 (43)	118 (54)	149 (68)
Coil (Wet)	8	12	-	-	-	-	-	109 (50)	137 (63)	174 (79)
Coil (Wet)	8	14	-	-	-	-	-	114 (52)	143 (65)	181 (83)
Coil (Wet)	8	16	-	-	-	-	-	119 (54)	150 (69)	189 (86)
Coil (Dry)	1	12	5 (3)	6 (3)	7 (4)	9 (5)	10 (5)	17 (8)	22 (10)	29 (14)
Coil (Dry)	1	14	5 (3)	6 (3)	8 (4)	9 (5)	10 (5)	18 (9)	23 (11)	30 (14)
Coil (Dry)	1	16	5 (3)	6 (3)	8 (4)	10 (5)	11 (5)	19 (9)	24 (11)	31 (15)
Coil (Dry)	2	12	7 (4)	8 (4)	10 (5)	14 (7)	16 (8)	27 (13)	35 (16)	44 (20)
Coil (Dry)	2	14	8 (4)	9 (5)	11 (5)	15 (7)	17 (8)	28 (13)	36 (17)	46 (21)
Coil (Dry)	2	16	8 (4)	9 (5)	11 (5)	15 (7)	17 (8)	30 (14)	38 (18)	48 (22)
Coil (Dry)	4	12	10 (5)	12 (6)	17 (8)	22 (10)	27 (13)	44 (20)	56 (26)	71 (33)
Coil (Dry)	4	14	10 (5)	13 (6)	18 (9)	23 (11)	28 (13)	46 (21)	59 (27)	75 (35)
Coil (Dry)	4	16	11 (5)	14 (7)	19 (9)	25 (12)	30 (14)	49 (23)	63 (29)	79 (36)
Coil (Dry)	6	12	13 (6)	17 (8)	23 (11)	31 (15)	37 (17)	61 (28)	77 (35)	97 (44)
Coil (Dry)	6	14	14 (7)	18 (9)	24 (11)	33 (15)	39 (18)	65 (30)	81 (37)	103 (47)
Coil (Dry)	6	16	14 (7)	19 (9)	25 (12)	35 (16)	42 (20)	68 (31)	86 (40)	109 (50)
Coil (Dry)	8	12	-	-	-	-	-	77 (35)	97 (44)	122 (56)
Coil (Dry)	8	14	-	-	-	-	-	82 (38)	103 (47)	130 (59)
Coil (Dry)	8	16	-	-	-	-	-	86 (40)	109 (50)	138 (63)
DX Normal	3	12	9 (5)	11 (5)	15 (7)	20 (10)	24 (11)	-	-	-
DX Interlaced	3	12	-	-	-	-	-	36 (17)	48 (22)	60 (28)
DX Normal	3	14	9 (5)	12 (6)	16 (8)	21 (10)	25 (12)	-	-	-
DX Interlaced	3	14	-	-	-	-	-	38 (18)	50 (23)	63 (29)
DX Normal	3	16	9 (5)	12 (6)	17 (8)	22 (10)	26 (12)	-	-	-
DX Interlaced	3	16	-	-	-	-	-	40 (19)	52 (24)	66 (30)
DX Normal	6	12	14 (7)	19 (9)	26 (12)	35 (16)	42 (20)	67 (31)	85 (39)	107 (49)
DX Interlaced	6	12	-	-	-	-	-	64 (30)	84 (39)	107 (49)
DX Normal	6	14	15 (7)	20 (10)	27 (13)	37 (17)	44 (20)	71 (33)	90 (41)	113 (52)
DX Interlaced	6	14	-	-	-	-	-	68 (31)	89 (41)	113 (52)
DX Normal	6	16	16 (8)	21 (10)	28 (13)	39 (18)	47 (22)	74 (34)	94 (43)	119 (54)
DX Interlaced	6	16	-	-	-	-	-	71 (33)	93 (43)	119 (54)
Standard Cabinet (FC Fans)	-	-	119 (54)	119 (54)	119 (54)	170 (78)	170 (78)	315 (143)	336 (153)	373 (170)
Standard Cabinet (Plenum Fans)	-	-	-	-	-	-	-	272 (124)	332 (151)	340 (155)
Mixing Box	-	-	-	-	-	-	-	88 (40)	97 (44)	105 (48)
Discharge Plenum	-	-	20 (10)	23 (11)	25 (12)	33 (15)	35 (16)	48 (22)	52 (24)	56 (26)
Primary Valve Package	-	-	6 (3)	6 (3)	9 (4)	10 (5)	12 (5)	-	-	-
Heating Valve Package	-	-	4 (2)	4 (2)	6 (3)	6 (3)	8 (4)	-	-	-

## Fan and Motor Data

**Table 13: Horizontal Fan and Motor Data (Forward-Curved Fans)**

Forward-Curved Fan Data										
Unit Size	006	008	010	012	016	018	020	030	040	050
Fan Quantity	1	1	1	1	2	2	2	1	1	1
Fan Type	FC, DWDI	FC, DWDI	FC, DWDI	FC, DWDI	FC, DWDI	FC, DWDI	FC, DWDI	FC, DWDI	FC, DWDI	FC, DWDI
Fan Size	9.5" X 4.5"	9.5" X 4.5"	9.5" X 4.5"	9.5" X 4.5"	9.5" X 4.5"	9.5" X 4.5"	9.5" X 4.5"	10" X 10"	12" X 12"	12" X 12"
Maximum RPM	2065	2065	2065	2065	2065	2065	2065	2100	1800	1800
Class	1	1	1	1	1	1	1	2	2	2
EC Motors	1	1	1	1	2*	2*	2*	–	–	–
Poly Phase Motors	–	–	–	–	–	–	–	1	1	1
1/3 HP	X	X			X					
1/2 HP	X	X	X	X	X	X	X			
3/4 HP	X	X	X	X	X	X	X			
1 HP			X	X		X	X			
1½ HP								X		
2 HP								X	X	
3 HP								X**	X	
5 HP									X**	X
7½ HP										X**

\* Motors are the same HP  
 \*\* HP is limited by VFD size

**Table 14: Horizontal Fan and Motor Data (Plenum Supply Fans)**

Plenum Fan Data			
Unit Size	30	40	50
Fan Quantity	1	2	2
Fan Type	Plenum Fan	Plenum Fan	Plenum Fan
Fan Size	355 mm	355 mm	355 mm
Maximum RPM	3300	3300	3300
EC Motors	1	2	2
Poly Phase EC Motors	1	2	2
Motor 4.42 HP	X	X	X

**Table 16: Sizes 060-100 Fan and Motor Data (Plenum Supply Fans)**

Plenum Fan Data			
Unit Size	060	080	100
Fan Quantity	1 or 2	1 or 2	1 or 2
Fan Type	Plenum Fan	Plenum Fan	Plenum Fan
Fan Size	450 mm	450 mm	450 mm
Maximum RPM	2600	2600	2600
EC Motors	1 or 2	1 or 2	1 or 2
Poly Phase EC Motors	1 or 2	1 or 2	1 or 2
Motor 3.7 HP	x	x	x
Motor 6.63 HP	x	x	x

**Table 15: Sizes 060-100 Fan and Motor Data (Forward-Curved Fans)**

Forward-Curved Fan Data			
Unit Size	060	080	100
Fan Quantity	1 or 2	2 or 3	2 or 3
Fan Type	FC, DWDI	FC, DWDI	FC, DWDI
Fan Size	9.5" X 4.5"	9.5" X 4.5"	9.5" X 4.5"
Maximum RPM	2065	2065	2065
Class	1	1	1
EC Motors	1 or 2	2 or 3	2 or 3
Poly Phase EC Motors	1 or 2	2 or 3	2 or 3
Motor 1/2 HP	x	x	x
Motor 1 HP	x	x	x



**Table 17: Vertical Fan and Motor Data (FC)**

Forward-Curved Fan Data								
Unit Size	006	008	012	016	020	030	040	050
Fan Quantity	1	1	1	2	2	1	1	1
Fan Type	FC, DWDI	FC, DWDI	FC, DWDI	FC, DWDI	FC, DWDI	FC, DWDI	FC, DWDI	FC, DWDI
Fan Size	9.5" X 4.5"	9.5" X 4.5"	9.5" X 4.5"	9.5" X 4.5"	9.5" X 4.5"	10.5" x 10.5"	12.5" x 12.5"	12.5" x 12.5"
Maximum RPM	2065	2065	2065	2065	2065	2100	1800	1800
Class	1	1	1	1	1	2	2	2
EC Motors	1	1	1	2*	2*	-	-	-
Poly Phase Motors	-	-	-	-	-	1	1	1
Motor 1/3 HP	X	X		X				
Motor 1/2 HP	X	X	X	X	X			
Motor 3/4 HP	X	X	X	X	X			
Motor 1 HP			X		X			
Motor 1½ HP**						X		
Motor 2 HP**						X	X	
Motor 3 HP**						X	X	
Motor 5 HP							X	X
Motor 7½ HP								X

\* Motors are the same HP

\*\* HP is limited by VFD size

**Table 18: Vertical Fan and Motor Data (Plenum)**

Plenum Fan Data			
Unit Size	30	40	50
Fan Quantity	1	2	2
Fan Type	Plenum Fan	Plenum Fan	Plenum Fan
Fan Size	355 mm	355 mm	355 mm
Maximum RPM	3300	3300	3300
EC Motors	1	2	2
Poly Phase Motors	1	2	2
Motor 4.42 HP	X	X	X

## Horizontal Filter Data

**Table 19: Filter Data for Main Unit and Optional Mixing Box**

Main Unit Filters														
Unit Size	006	008	010	012	016	018	020	030	040	050	060	080	100	
Quantity	1	1	2	2	2	2	2	2	2	2	4	6	3	6
Height (inches)	17.69							25.38	29.75	28.00	24.00	18.00	20.00	20.00
Width (inches)	12.13	17.13	13.75		17.94	22.25		21.88	24.50	27.81	24.00	24.00	16.00	20.00
Nom. Face Velocity (FPM)	421	393	296	355	363	329	366	389	395	408	375	444	429	
(Optional) Mixing Box Filters														
Quantity	1	1	2	2	2	2	2	2	2	2	4	6	3	
Height (inches)	18.50							23.50	27.50	29.50	24.00	24.00	16.00	
Width (inches)	12.50	17.50	12.75		17.00	21.25		23.25	25.75	29.25	24.00	18.00	20.00	

## Vertical Filter Data

**Table 20: Filter Data for Main Unit and Optional Mixing Box**

Main Unit Filters									
External									
Unit Size	006	008	012	016	020	030	040		050
Quantity	1	1	1	2	2	2	2	2	4
Height (inches)	12	12	18	16	20	25	12	20	20
Width (inches)	24	24	24	20	20	20	24	24	24
Nom. Face Velocity (FPM)	300	400	300	360	450	432	375		375
Internal Filter Rack									
Quantity	1	1	1	2	2	-	-	-	-
Height (inches)	12	18	20	16	16	-	-	-	-
Width (inches)	20	24	24	20	20	-	-	-	-
(Optional) Mixing Box Filters									
Quantity	-	-	-	-	-	2	4	4	
Height (inches)	-	-	-	-	-	24	16	20	
Width (inches)	-	-	-	-	-	20	20	20	

**Table 21: Filter Pressure Drop**

Clean Pressure Drop	Face Velocity (Feet per minute)				
	100	200	300	400	500
2" Filter					
Merv 4	0.02	0.04	0.08	0.11	0.16
Merv 8	0.02	0.07	0.12	0.19	0.27
Merv 13	0.08	0.17	0.27	0.37	0.48
4" Filter					
Merv 8	0.01	0.03	0.06	0.1	0.14
Merv 13	0.02	0.07	0.12	0.19	0.27

## Unit Selection

A mechanical heating, ventilation, and cooling system realizes thermal comfort and high efficiency through accurate space design and thoughtful equipment selection. Variations and limitations of centralized air handler systems and de-centralized fan coil systems are not outlined in this manual but must be fully understood. Design conditions and load calculations are not discussed in detail in this catalog but can be further explored and studied in the ASHRAE Guide. This catalog includes AHRI-certified ratings which a design engineer may make use of in initial system design and equipment specification.

A mechanical system designer must select the unit types best suited to the overall system before the actual unit sizes can be determined. The factors that generally influence this decision are: intended building usage, building layout, architectural and aesthetic values, economics, geographical location, and type of maintenance service available. The general results may be a mixture of unit types within a given system. Daikin Applied manufactures fan coil units to meet many needs including ThinLine, OptiLine, and Economy models. For Daikin Applied product information, please go to [www.DaikinApplied.com](http://www.DaikinApplied.com).

### Basic Design Data

Prior to selecting individual unit sizes, a design engineer must fix or determine the following factors:

- Inside and outside wet and dry bulb design temperatures
- Total and sensible heat gains and losses of the area to be served
- Ventilation air
- Properties of the heating and cooling medium
- Available electric power service
- Any special design requirements of the building or system

### Unit Size

The capacity ratings presented in this catalog are provided for initial unit selection only. Water cooling and heating capacities, unit air flow, static pressure and glycol solutions are all incorporated into Daikin Applied Select Tools to provide the best possible selection. Consult your Daikin Applied representative for a selection tailored to specific applications. Unit sizes for the ideal system should be selected by calculating peak load requirements due to unusually high occupancy or severe climatic conditions and with fans operating at high speed. Ordinary day-to-day cooling and heating requirements are then achieved at low and medium speeds. The initial unit selection should be checked for air volume in the design system and the cooling capacities checked against actual operating conditions. While units selected on the basis of sensible load will generally meet the total cooling load, total load should be checked in all cases. The unit size is generally selected on the basis of matching the sensible cooling capacity of the unit with the calculated requirements when operating at high speed.

### Coil Types

Standard coils are designed to meet both cooling and heating requirements in a typical system. Multiple primary coil options are available to meet the total and sensible requirements of any application. Heating requirements for systems are generally met by specifying entering water temperature and leaving water temperature, allowing a water flow rate to be calculated.

Four-pipe and Two-pipe systems are available. Daikin Applied offers two coil options for preheat or reheat.

### Four-Pipe Systems

Four-Pipe systems refer to a piece of air handling equipment that utilizes two distinct coils. One of the coils only operates in a cooling mode, and the other coil only operates in a heating mode. The advantage to this system setup is the ability to let the unit choose whether to employ cooling or heating mode at any one instant. During the shoulder seasons when space loads change based on sun exposure, occupant activity, plug loads, and other factors, some thermal spaces may require cooling while others require heating. Because the unit has two distinct coils piped to the chiller and boiler systems individually, the unit can choose which system to use.

### Two-Pipe Systems

Two-Pipe systems refer to a piece of air handling equipment that utilizes a single coil. This coil can operate as a cooling only coil, a cooling and heating coil, or a heating coil. The "two-pipe" designation comes from how typically only two fluid pipes, one supply and one return, are run to each unit. The advantage to this system is first cost. Only one set of pipes (one return, one supply) to the unit is necessary. This effectively cuts the piping material cost in half.

### Four and Two-Pipe Performance Measurements

All performance data is given assuming nominal cabinet airflow, which is achievable with up to 1.5" of external static pressure.

Cooling performance is based on 80/67°F (27/19°C) entering air temperature, 45°F (7°C) entering chilled water temperature with a 10°F (5.5°C) temperature rise.

Heating performance is based on 70°F (21°C) entering air temperature, 180°F (82°C) entering hot water temperature with a 30°F (17°C) temperature drop.

For other conditions and/or unit configurations, refer to DaikinTools™ selection program or talk to your local Daikin Applied representative

## Electrical Data

Calculations to realize MCA (Maximum Circuit Ampacity) and MROPD (Maximum Rated Overcurrent Protection Device) are explained in this section. MROPD (Maximum Rated Overcurrent Protection Device), MOP (Maximum Overcurrent Protection), MFS (Maximum Fuse Size) are synonymous in this section.

The minimum circuit ampacity (MCA) is the minimum conductor size required for a field-wired product. The MROPD (Maximum Rated Overcurrent Protection Device), MOP (Maximum Overcurrent Protection), or MFS (Maximum Fuse Size) is the maximum fuse or circuit breaker size required to properly protect the equipment. The MROPD will always be greater than the MCA for any given supply circuit.

The circuit's required fusing or HACR (Heating, Air-Conditioning and Refrigeration) type circuit breaker size is determined from the circuit's MCA and calculated MROPD.

$$\text{Heater Amps} = \left( \frac{\text{Heater kW} \times 1000}{\text{Heater Voltage}} \right)$$

NOTE: Use 120V heater voltage for 115V units. Use 240V heater voltage for 230V units.

$$\text{MCA} = 1.25 \times (\text{Heater Amps} + \text{all motor FLAs})$$

$$\text{Calculated MROPD} = 2.25 \times (\text{Largest Motor FLA's} + \text{Other Motor FLA's} + \text{Electric Heater Amps})$$

The circuit's MROPD is the next standard size fuse smaller than the calculated MROPD if that standard fuse sizes is greater than the MCA.

If the MCA is greater than the next standard size fuse smaller than the calculated MROPD, the circuit's MROPD is the next standard size fuse larger than the MCA.

If the circuit's MROPD is smaller than 15A, it shall be rounded up to 15A.

The temperature of the air leaving the unit (LAT) which is dependent on the entering air temperature (EAT), electric heat capacity (kW), and the air volume (CFM), must not exceed 125°F. The minimum allowable air volume for various combinations of EAT and kW are provided in [Table 32 on page 46](#) or may be calculated using the equation below.

$$\text{LAT} = (\text{kW} \times 3145.622 \div \text{CFM}) + \text{EAT}$$

## Electric Heat Safety

### Overcurrent Protection

Optional factory provided over current protection is available on all units with a maximum operating current less than or equal to 48 amps. This protection is provided with fuses located on the unit main power circuit. Units with a maximum operating current greater than 48 amps will come with factory-installed fusing on the electric heat circuit.

### Thermal (Over Temperature) Protection

All units with electric heat are provided with at least two thermal protection devices. The primary thermal protection device is an automatic limit switch which opens when it reaches a temperature of 150°F. The switch will reset itself when the temperature drops below 110°F. The secondary thermal protection device is a manual reset thermal cutout. This switch opens when it reaches 180°F for horizontal units and 210°F for vertical units, but must be reset manually after the over temperature issue has been resolved. Units provided with the SCR type electric heat control have an additional automatic thermal protection built into the SCR controller. This switch opens the circuit when the temperature reaches 170°F.

### Valve Package Selections

All factory-installed valve packages are configurable through Daikin Applied Select Tools for GPM, Cv, and control type. Factory-installed valve packages ship with foam inserts for added support. Factory-installed valve packages include unions for easy removal of cooling and heating coils.

The optional factory-installed deluxe valve package includes a temperature control valve, a ball shut off valve with supply strainer, P/T port and clean out, and an automatic flow control valve with ball shut off and P/T ports. The temperature control valve is the Belimo B series characterized flow ball valve with SS ball and stem and is selectable as 2-way or 3-way. The valve flow coefficient and connection ports are appropriately sized for the selected flow rate. The control actuator can be configured for spring return on-off normally closed to the coil, spring return on-off normally open to the coil or non-spring return 0-10VDC modulating control. The strainer and ball shut off valve assembly is the Nexus UltraY and the automatic flow control valve and shut off assembly is the Nexus UltraMatic model UM. The piping schematic examples are shown in Figure 33 through Figure 38.

On vertical units Size 06 and 08, the control valve is a Belimo Zonetight. These valves can be selected as either 2-way or 3-way, N.O. or N.C, and have a manually adjustable Cv ranging from 0.5 to 5.9. **These valves are located on the supply side, adjacent to the coil, in contrast with other configurations being located on the return side.**

Figure 33: Basic 2-Way Valve Package

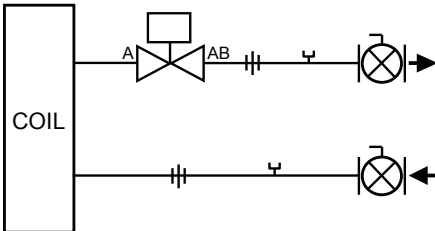


Figure 34: Basic 3-Way Valve Package

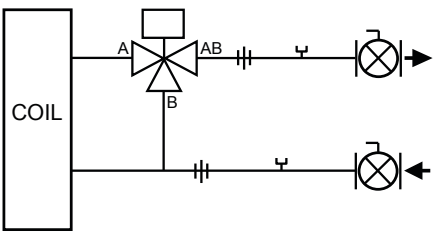


Figure 35: Deluxe 2-Way Valve Package (Auto CS)

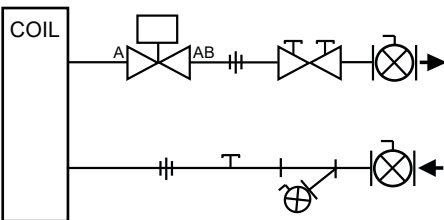


Figure 36: Deluxe 3-Way Valve Package (Auto CS)

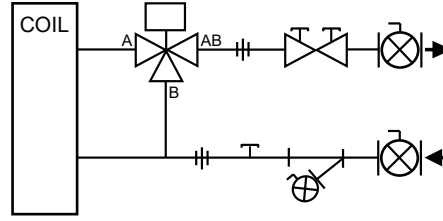


Figure 37: Deluxe 2-Way Valve Package (Manual CS)

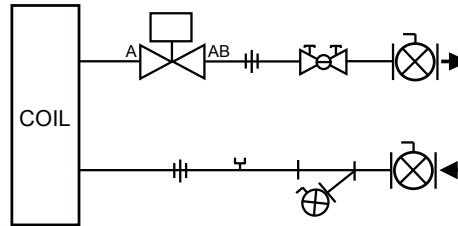


Figure 38: Deluxe 3-Way Valve Package (Manual CS)

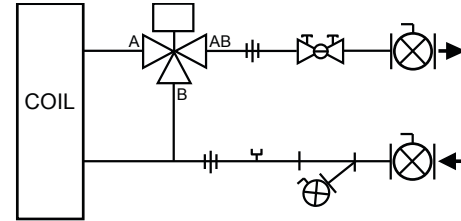


Figure 39: Components Key for Schematics

	<b>Manual Shutoff Ball Valve with Memory Stop:</b> Used on return line for limiting water flow.
	<b>2-Way, ON/OFF Valve:</b> Turn ON or OFF water flow to the coil in response to 24V or line voltage signal
	<b>3-Way, ON/OFF Valve:</b> Bypass water flow away from coil in response to 24V or line voltage signal. Includes fixed orifice for balancing.
	<b>PT Port:</b> For connecting a pressure or temperature gauge.
	<b>Y-Strainer:</b> Removable screen filters out small particles from supply line during normal system operation.
	<b>Auto Circuit Setter:</b> Pressure-compensated, automatic flow control.
	<b>Manual Circuit Setter:</b> Pressure-compensated, manual flow control.
	<b>Union:</b> For easy removal of piping from coil.

Note: Daikin Applied 3-way valves are equipped with a fixed balance orifice in the bypass line, eliminating the need for a separate balancing valve

# Performance Data

**Table 23: Horizontal Primary Coil Performance Data**

Unit Size	Nominal Air Flow SCFM	Number of Rows	Fins per Inch	Cooling Performance				Heating Performance		
				Total MBH	Sensible MBH	GPM	Pressure Drop (PSI)	Total MBH	GPM	Pressure Drop (PSI)
006	600	2	12	8285	8262	1.6	1.2	38546	3.9	4.2
	600	4	12	19780	14993	3.8	9.1	58375	6.0	15.6
	600	6	12	26520	18016	5.1	23.3	66142	6.8	28.7
	600	6	16	29069	19152	5.6	27.5	69062	7.1	31.0
008	800	2	12	13411	12686	2.5	2.9	52336	5.3	8.0
	800	4	12	28563	20882	5.5	19.5	78334	8.0	28.9
	800	6	12	32768	22938	6.3	6.1	87502	9.0	8.0
	800	6	16	36106	24405	6.9	7.1	91537	9.4	8.7
010	1000	2	12	22596	19085	4.1	8.4	71854	7.1	16.1
	1000	4	12	36476	26570	7.0	6.0	101574	10.0	8.0
	1000	6	12	47218	31347	9.1	14.1	112881	11.2	14.3
	1000	6	16	51232	33140	9.8	16.1	116798	11.5	14.9
012	1200	2	12	24882	21488	4.5	9.9	80775	8.2	20.9
	1200	4	12	41192	30655	7.9	7.5	117189	11.9	10.9
	1200	6	12	54109	36483	10.3	17.6	132547	13.5	19.9
	1200	6	16	59299	38805	11.4	21.1	138342	14.1	21.5
016	1600	2	12	28010	26033	5.1	3.1	105752	10.8	8.0
	1600	4	12	58780	42443	11.3	16.4	157291	16.1	21.6
	1600	6	12	67038	46500	13.6	4.7	175003	18.0	5.0
	1600	6	16	73468	49340	14.7	5.4	183116	18.9	5.5
018	1800	2	12	38310	33023	7.0	6.1	115294	7.8	4.8
	1800	4	12	65041	47467	12.5	8.5	172429	11.7	4.8
	1800	6	12	80327	54413	15.4	6.8	195031	13.2	3.4
	1800	6	16	87830	57733	16.8	7.9	204398	13.8	3.7
020	2000	2	12	40566	35381	7.4	6.7	134189	13.7	13.7
	2000	4	12	69725	51524	13.4	9.6	195600	20.0	12.5
	2000	6	12	87523	59682	17.0	8.1	220097	22.6	8.7
	2000	6	16	95586	63274	18.3	9.2	229920	23.6	9.4
030	3000	2	12	59500	52417	10.9	3.5	199425	19.7	10.1
	3000	4	12	103472	76822	19.9	7.0	291924	28.8	12.4
	3000	6	12	135652	91362	25.9	16.7	330663	32.7	21.3
	3000	6	16	148418	97087	28.5	19.7	345344	34.1	23.0
	3000	8	12	150537	97997	29.4	11.8	340113	23.1	5.4
	3000	8	16	160769	102575	31.4	13.2	350496	23.8	5.7
040	4000	2	12	83419	71800	15.2	5.1	267202	26.3	14.8
	4000	4	12	142700	104367	27.4	10.2	390733	38.6	18.1
	4000	6	12	176943	120156	34.1	9.1	439636	43.5	9.7
	4000	6	16	193604	127593	37.1	10.6	459471	45.4	10.5
	4000	8	12	203791	132010	39.8	16.2	454552	30.9	7.2
	4000	8	16	217118	138007	42.4	18.1	468126	31.8	7.6

Unit Size	Nominal Air Flow SCFM	Number of Rows	Fins per Inch	Cooling Performance				Heating Performance		
				Total MBH	Sensible MBH	GPM	Pressure Drop (PSI)	Total MBH	GPM	Pressure Drop (PSI)
050	5000	2	12	109441	92070	19.9	8.1	337534	34.3	23.6
	5000	4	12	172338	127969	33.1	5.5	487418	49.5	7.7
	5000	6	12	226130	152283	43.2	13.5	551645	56.1	14.8
	5000	6	16	247378	161816	47.5	15.9	576028	58.6	16.0
	5000	8	12	258465	166654	50.4	23.9	569502	38.7	10.5
	5000	8	16	275388	174312	53.7	26.7	586203	39.9	11.0
060	6000	2	12	119001	104835	21.8	3.5	398849	19.7	20.2
	6000	4	12	206944	153644	39.8	7.0	583847	28.8	24.8
	6000	6	12	271304	182724	51.8	16.7	661326	32.7	42.6
	6000	6	16	296835	194173	57.0	19.7	690689	34.1	46.0
	6000	8	12	301074	195994	58.8	26.3	680226	23.1	10.7
	6000	8	16	321538	205151	62.8	29.5	700991	23.8	11.3
080	8000	2	12	166839	143600	30.4	5.1	534403	26.3	29.5
	8000	4	12	285400	208734	54.8	10.2	781467	38.6	36.2
	8000	6	12	353885	240313	68.2	9.1	879272	43.5	19.5
	8000	6	16	387208	255186	74.2	10.6	918941	45.4	21.0
	8000	8	12	407581	264019	79.6	16.2	909105	30.9	14.5
	8000	8	16	434237	276014	84.8	18.1	936252	31.8	15.2
100	10000	2	12	218881	184140	39.8	8.1	675068	34.3	47.2
	10000	4	12	344676	255939	66.2	5.5	974836	49.5	15.5
	10000	6	12	452261	304566	86.4	13.5	1103289	56.1	29.7
	10000	6	16	494756	323633	95.0	15.9	1152055	58.6	32.0
	10000	8	12	516931	333308	100.8	23.9	1139003	38.7	20.9
	10000	8	16	550777	348624	107.4	26.7	1172406	39.9	22.1

Cooling Conditions: EAT = 80/67, EWT = 45, LWT = 55  
 Heating Conditions: EAT = 70, EWT = 180, LWT = 160

**Table 24: Horizontal Secondary Coil Performance Data**

Unit Size	Nominal Air Flow SCFM	Number of Rows	Fins per Inch	Heating Performance		
				Total MBH	GPM	Pressure Drop (PSI)
006	600	1	12	22847	1.6	11.1
	600	1	16	27674	1.9	15.0
	600	2	12	34341	2.3	1.6
	600	2	16	39822	2.7	2.2
008	800	1	12	30681	2.1	20.1
	800	1	16	37213	2.5	27.2
	800	2	12	47375	3.2	3.3
	800	2	16	54704	3.7	4.3
010	1000	1	12	39210	2.7	2.2
	1000	1	16	47120	3.2	3.0
	1000	2	12	66353	4.5	7.2
	1000	2	16	76002	5.2	9.3
012	1200	1	12	42106	2.9	2.5
	1200	1	16	51100	3.5	3.5
	1200	2	12	74395	5.1	9.0
	1200	2	16	85512	5.8	11.3



Unit Size	Nominal Air Flow SCFM	Number of Rows	Fins per Inch	Heating Performance		
				Total MBH	GPM	Pressure Drop (PSI)
016	1600	1	12	57591	3.9	4.8
	1600	1	16	70294	4.8	7.0
	1600	2	12	96106	6.5	3.2
	1600	2	16	110893	7.5	4.1
018	1800	1	12	71362	4.9	7.9
	1800	1	16	86405	5.9	11.2
	1800	2	12	115608	7.9	5.0
	1800	2	16	132455	9.0	6.4
020	2000	1	12	74335	5.1	8.5
	2000	1	16	90144	6.1	11.9
	2000	2	12	123139	8.4	5.6
	2000	2	16	141713	9.6	7.2
030	3000	1	12	111161	7.6	6.2
	3000	1	16	135183	9.2	8.7
	3000	2	12	183660	12.5	4.4
	3000	2	16	211760	14.4	5.7
040	4000	1	12	149701	10.2	9.0
	4000	1	16	181940	12.3	12.8
	4000	2	12	246953	16.8	6.5
	4000	2	16	284843	19.4	8.5
050	5000	1	12	190133	13.0	13.8
	5000	1	16	231263	15.7	19.6
	5000	2	12	311141	21.1	9.7
	5000	2	16	358946	24.4	12.7
060	6000	1	12	222322	15.2	6.2
	6000	1	16	270365	18.4	8.7
	6000	2	12	367321	25.0	4.4
	6000	2	16	423521	28.8	5.7
080	8000	1	12	299402	20.4	9.0
	8000	1	16	363881	24.6	12.8
	8000	2	12	493905	33.6	6.5
	8000	2	16	569686	38.8	8.5
100	10000	1	12	380266	26.0	13.8
	10000	1	16	462525	31.4	19.6
	10000	2	12	622283	42.2	9.7
	10000	2	16	717893	48.8	12.7

**Table 25: Vertical Primary Coil Performance Data**

Unit Size	Nominal Air Flow SCFM	Number of Rows	Fins per Inch	Cooling Performance				Heating Performance		
				Total MBH	Sensible MBH	GPM	Pressure Drop (PSI)	Total MBH	GPM	Pressure Drop (PSI)
006	600	2	12	10384	9751	2.4	2.5	38546	3.9	4.2
	600	4	12	20354	15231	4.1	10.4	58375	6	15.6
	600	6	12	22634	16412	4.5	3.0	65245	6.8	4.4
	600	6	16	25421	17613	5.1	3.8	68317	7.1	4.7
008	800	2	12	16072	14127	3.6	5.0	52427	5.3	6.7
	800	4	12	21502	17968	4.3	1.5	76399	8	3.5
	800	6	12	32078	22656	6.4	4.4	87261	9	6.1
	800	6	16	35542	24168	7.1	5.3	91329	9.4	6.6
012	1200	2	12	25258	21627	5.7	6.8	81294	10.8	14.6
	1200	4	12	36969	28873	7.4	3.6	117392	16.1	11.0
	1200	6	12	51162	35229	10.2	9.1	132683	18	18.4
	1200	6	16	56333	37525	11.3	10.9	138468	18.9	20.1
016	1600	2	12	29250	26882	7	1.7	108048	13.7	4.5
	1600	4	12	55369	41072	11.1	6.8	158908	20	14.7
	1600	6	12	65316	45795	12.9	4.5	177265	22.6	9.8
	1600	6	16	72818	49067	14.6	5.6	184737	23.6	10.6
020	2000	2	12	40853	35652	9.5	3.2	140601	23.1	12.6
	2000	4	12	63352	48917	12.7	3.4	197631	26.3	10.4
	2000	6	12	87141	59521	17.4	8.3	224423	38.6	28.4
	2000	6	16	95856	63390	19.2	9.9	233321	43.5	35.2
030	3000	2	12	65773	55660	14.7	4.1	219457	45.4	36.9
	3000	4	12	102379	76467	20.5	5.2	294492	30.9	10.8
	3000	6	12	135945	91512	27.2	12.7	332094	34.3	17.3
	3000	6	16	148481	97120	29.7	14.9	348412	49.5	10.2
	3000	8	16	159545	102028	31.9	9.3	357445	56.1	38.7
040	4000	2	12	86452	73332	18.1	5.9	289056	58.6	39.6
	4000	4	12	140068	103293	28	8.1	388985	38.7	11.3
	4000	6	12	173928	118890	34.8	6.7	438217	43.5	6.8
	4000	6	16	191140	126533	38.2	7.9	458315	45.4	7.4
	4000	8	16	214869	136996	43	16.1	466495	30.9	5.1
050	5000	2	12	111359	93297	24.2	6.8	335266	34.3	10.2
	5000	4	12	176302	129673	35.3	8.8	488710	49.5	13.0
	5000	6	12	218061	148903	43.6	9.8	549724	56.1	7.1
	5000	6	16	239613	158466	47.9	11.7	574328	58.6	7.6
	5000	8	16	269144	171496	53.9	17.4	583644	38.7	5.0

**Table 26: Vertical Secondary Coil Performance Data**

Unit Size	Nominal Air Flow SCFM	Number of Rows	Fins per Inch	Heating Performance		
				Total MBH	GPM	Pressure Drop (PSI)
006	600	1	12	20855	1.4	1.2
	600	2	12	34726	2.4	1.8
	600	2	16	39822	2.7	2.2
008	800	1	12	29043	2	2.9
	800	2	12	47804	3.3	2.9
	800	2	16	55135	3.8	3.7
012	1200	1	12	38550	2.6	0.7
	1200	2	12	71299	4.9	3.7
	1200	2	16	82196	5.6	4.7
016	1600	1	12	56894	3.9	1.6
	1600	2	12	93484	6.4	1.1
	1600	2	16	107930	7.4	1.5
020	2000	1	12	72252	4.9	2.7
	2000	2	12	119338	8.2	1.9
	2000	2	16	137497	9.4	2.5
030	3000	1	12	101901	6.9	0.6
	3000	2	12	184159	12.6	3.4
	3000	2	16	212101	14.5	4.5
040	4000	1	12	135748	9.2	0.9
	4000	2	12	244336	16.7	4.0
	4000	2	16	281953	19.3	5.2
050	5000	1	12	171113	11.6	0.9
	5000	2	12	307110	21	4.2
	5000	2	16	354011	24.2	5.4

Heating Conditions: EAT = 70, EWT = 180, LWT = 150

**Table 27: Horizontal DX Coil Performance Data**

Unit Size	Circuits		Fin Height	Finned Length	CFM	EAT		Suction Temp	FPI	Total	Sensible	LAT		APD	Connection Size	
	Number	Type				DB	WB					DB	WB		Liquid	Suction
006	1	Normal	14	12.5	600	80	67	45	12	20455	14797	57.5	56.2	0.379	0.500	0.750
									16	23060	16253	55.2	54.6	0.518	0.500	0.750
008	1	Normal	14	16.5	800	80	67	45	12	27983	20000	57.1	55.8	0.385	0.500	0.750
									16	31279	21882	55.0	54.4	0.525	0.500	0.750
010	1	Normal	14	25	1000	80	67	45	12	35464	25461	56.7	55.7	0.290	0.500	0.875
									16	40060	27887	54.5	54.0	0.400	0.500	0.875
012	1	Normal	14	25	1200	80	67	45	12	39519	29041	57.9	56.6	0.379	0.500	0.875
									16	44926	32018	55.6	55.0	0.518	0.500	0.875
016	1	Normal	14	33	1600	80	67	45	12	55588	39849	57.2	55.9	0.385	0.500	1.125
									16	62680	43813	55.0	54.3	0.525	0.500	1.125
018	1	Normal	14	41.5	1800	80	67	45	12	67101	46958	56.1	55.0	0.327	0.500	1.125
									16	74718	51177	54.0	53.5	0.449	0.500	1.125
020	1	Normal	22	41.5	2000	80	67	45	12	71003	50440	56.9	55.7	0.382	0.500	1.125
									16	79274	55156	54.8	54.2	0.521	0.500	1.125
030	1	Normal	22	39.5	3000	80	67	45	12	106172	75513	57.0	55.7	0.383	0.875	1.375
									16	118817	82688	54.8	54.2	0.523	0.875	1.375
	2	Interlaced	22	39.5	3000	80	67	45	12	106172	75513	57.0	55.7	0.383	0.500	0.875
									16	118817	82688	54.8	54.2	0.523	0.500	0.875
040	1	Normal	26	44.5	4000	80	67	45	12	141746	100750	57.0	55.7	0.384	0.875	1.375
									16	157734	109963	54.9	54.2	0.524	0.875	1.375
	2	Interlaced	26	44.5	4000	80	67	45	12	150755	105289	54.9	54.9	0.384	0.625	1.125
									16	157734	109963	54.9	54.2	0.524	0.625	1.125
050	1	Normal	28	51.5	5000	80	67	45	12	175437	125212	57.1	55.8	0.386	0.875	1.625
									16	196935	137345	54.9	54.2	0.526	0.875	1.625
	2	Interlaced	28	51.5	5000	80	67	45	12	175437	125212	57.1	55.8	0.386	0.625	1.375
									16	196935	137345	54.9	54.2	0.526	0.625	1.375
060	2	Normal	22	39.5	6000	80	67	45	12	212344	151026	57	55.7	0.383	0.875	1.375
									16	237634	165376	54.8	54.2	0.523	0.875	1.375
	4	Interlaced	22	39.5	6000	80	67	45	12	212344	151026	57	55.7	0.383	0.5	0.875
									16	237634	165376	54.8	54.2	0.523	0.5	0.875
080	2	Normal	26	44.5	8000	80	67	45	12	283492	201500	57	55.7	0.384	0.875	1.375
									16	315468	219926	54.9	54.2	0.524	0.875	1.375
	4	Interlaced	26	44.5	8000	80	67	45	12	301510	210578	54.9	54.9	0.384	0.625	1.125
									16	315468	219926	54.9	54.2	0.524	0.625	1.125
100	2	Normal	28	51.5	10000	80	67	45	12	350874	250424	57.1	55.8	0.386	0.875	1.625
									16	393870	274690	54.9	54.2	0.526	0.875	1.625
	4	Interlaced	28	51.5	10000	80	67	45	12	350874	250424	57.1	55.8	0.386	0.625	1.375
									16	393870	274690	54.9	54.2	0.526	0.625	1.375

**Table 28: Vertical DX Coil Performance Data**

Unit Size	Rows	Circuits		Fin Height	Fin Length	CFM	EAT		Suction Temp	FPI	Total	Sensible	LAT		APD	Connection Size	
		Number	Type				DB	WB					DB	WB		Liquid	Suction
006	3	1	Normal	14	12.5	600	80	67	45	12	20872.0	15099.0	57.0	55.9	0.379	0.5	0.75
										16	23530.5	16584.7	54.7	54.3	0.518	0.5	0.75
006	6	1	Normal	14	12.5	600	80	67	45	12	29309.7	19134.1	50.7	50.6	0.759	0.5	0.75
										16	30804.0	19785.5	49.7	49.6	1.036	0.5	0.75
008	3	1	Normal	16	14.5	800	80	67	45	12	27761.6	20098.1	57.0	55.9	0.383	0.5	0.875
										16	31321.4	22087.5	54.8	54.3	0.522	0.5	0.875
008	6	1	Normal	16	14.5	800	80	67	45	12	39577.5	25727.7	50.5	50.4	0.765	0.5	0.875
										16	42128.9	26848.2	49.1	49.1	1.044	0.5	0.875
012	3	1	Normal	18	18.5	1200	80	67	45	12	40690.8	29684.9	57.4	56.2	0.408	0.5	1.125
										16	44497.9	32084.5	55.5	55.1	0.556	0.5	1.125
012	6	1	Normal	18	18.5	1200	80	67	45	12	58628.8	38272.4	50.7	50.6	0.816	0.625	1.125
										16	61932.8	39714.1	49.6	49.5	1.111	0.625	1.125
016	3	1	Normal	20	23.5	1600	80	67	45	12	57671.9	41085.1	56.5	55.5	0.375	0.625	1.125
										16	63835.7	44680.7	54.5	54.1	0.513	0.625	1.125
016	6	1	Normal	20	23.5	1600	80	67	45	12	80324.8	51964.2	50.2	50.1	0.751	0.875	1.125
										16	85191.4	54112.6	48.9	48.9	1.025	0.875	1.125
020	3	1	Normal	20	29	2000	80	67	45	12	69672.3	50352.4	57.0	55.9	0.383	0.875	1.375
										16	78698.3	55379.4	54.7	54.3	0.522	0.875	1.375
020	6	1	Normal	20	29	2000	80	67	45	12	99493.2	64557.7	50.4	50.3	0.765	0.875	1.375
										16	104892.3	66929.6	49.2	49.2	1.044	0.875	1.375
030	3	1	Normal	26	34.5	3000	80	67	45	12	108667.6	77327.5	56.4	55.4	0.366	0.875	1.625
										16	122196.0	84846.8	54.1	53.7	0.500	0.875	1.625
		2	Interlaced	26	34.5	3000	80	67	45	12	108667.6	77327.5	56.4	55.4	0.366	0.625	0.875
										16	122196.0	84846.8	54.1	53.7	0.500	0.625	0.875
030	6	1	Normal	26	34.5	3000	80	67	45	12	—	—	—	—	—	—	—
										16	—	—	—	—	—	—	—
		2	Interlaced	26	34.5	3000	80	67	45	12	147704.9	96170.7	50.6	50.5	0.731	0.875	0.875
										16	154645.7	99203.1	49.6	49.6	1.000	0.875	0.875
040	3	1	Normal	30	38.5	4000	80	67	45	12	144032.4	102551.0	56.6	55.5	0.385	0.875	1.625
										16	161384.1	112377.9	54.3	53.9	0.525	0.875	1.625
		2	Interlaced	30	38.5	4000	80	67	45	12	144032.4	102551.0	56.6	55.5	0.385	0.875	1.125
										16	161384.1	112377.9	54.3	53.9	0.525	0.875	1.125
040	6	1	Normal	30	38.5	4000	80	67	45	12	—	—	—	—	—	—	—
										16	—	—	—	—	—	—	—
		2	Interlaced	30	38.5	4000	80	67	45	12	198736.5	129006.9	50.4	50.3	0.770	0.875	1.375
										16	211839.4	134773.2	49.0	49.0	1.050	0.875	1.375
050	3	1	Normal	38	38.5	5000	80	67	45	12	181160.0	128739.0	56.5	55.4	0.378	0.875	1.625
										16	202916.3	141015.6	54.2	53.8	0.515	0.875	1.625
		2	Interlaced	38	38.5	5000	80	67	45	12	181160.0	128739.0	56.5	55.4	0.378	0.875	1.375
										16	202916.3	141015.6	54.2	53.8	0.515	0.875	1.375
050	6	1	Normal	38	38.5	5000	80	67	45	12	—	—	—	—	—	—	—
										16	—	—	—	—	—	—	—
		2	Interlaced	38	38.5	5000	80	67	45	12	249252.6	161620.3	50.3	50.2	0.755	0.875	1.625
										16	265538.3	168796.1	48.9	48.9	1.031	0.875	1.625

**Table 29: VRV Coil Performance Data**

Unit Size	Rows	Fin Height	Fin Length	CFM	EAT		Suction Temp	FPI	Total	Sensible	LAT		APD	Connection Size	
					DB	WB					DB	WB		Liquid	Suction
006	3	14	12.5	600	81	66	43	12	21157	16439	55.94	54.43	0.379	0.375	0.75
008	3	14	16.5	800	81	66	43	12	28855	22178	55.65	54.14	0.385	0.375	0.75
012	3	14	25	1200	81	66	43	12	41126	32372	56.33	54.79	0.379	0.375	0.875
016	3	14	33	1600	81	66	43	12	57534	44280	55.7	54.18	0.385	0.375	1.125
020	3	14	41.5	2000	81	66	43	12	73165	55897	55.44	53.95	0.382	0.375	1.125
030	3	22	39.5	3000	81	66	43	10	109502	83728	55.48	53.98	0.382	0.500	1.375
040	3	26	44.5	4000	81	66	43	12	145887	111580	55.5	54	0.384	0.625	1.375
050	3	28	51.5	5000	81	66	43	12	180084	138499	55.67	54.16	0.386	0.625	1.375
060	3	22	39.5	6000	81	66	45	10	219004	167456	55.48	53.98	0.383	0.5	1.375
080	3	26	44.5	8000	81	66	45	12	291774	223160	55.49	53.99	0.384	0.625	1.375
100	3	28	51.5	10000	81	66	45	12	360168	276998	55.67	54.16	0.386	0.625	1.625

**Table 30: Vertical Steam Coil Performance Data**

Unit Size	Nominal Air Flow SCFM	Number of Rows	Fins per Inch	EAT		PSI	Heating Performance	
				DB			Total MBH	Pressure Drop (PSI)
006	600	1	10	55		5	30049.0	0.18
008	800	1	10	55		5	41468.0	0.16
012	1200	1	10	55		5	61975.0	0.16
016	1600	1	10	55		5	87533.0	0.14
020	2000	1	10	55		5	106985.0	0.15
030	3000	1	10	55		5	151774.0	0.15
040	4000	1	10	55		5	202671.0	0.15
050	5000	1	10	55		5	258119.0	0.15

**Table 31: Horizontal Steam Coil Performance Data**

Unit Size	Nominal Air Flow SCFM	Number of Rows	Fins per Inch	EAT		PSI	Heating Performance	
				DB			Total MBH	Pressure Drop (PSI)
006	600	1	10	55		5	22229.0	0.36
008	800	1	10	55		5	33948.0	0.26
010	1000	1	10	55		5	54590.0	0.14
012	1200	1	10	55		5	57961.0	0.19
016	1600	1	10	55		5	80691.0	0.17
018	1800	1	10	55		5	97625.0	0.14
020	2000	1	10	55		5	101153.0	0.16
030	3000	1	10	55		5	153469.0	0.16
040	4000	1	10	55		5	207617.0	0.15
050	5000	1	10	55		5	264380.0	0.14
060	6000	1	10	55		5	306938	0.16
080	8000	1	10	55		5	415234	0.15
100	10000	1	10	55		5	528760	0.14



**Table 32: Horizontal Minimum Allowable Air Volume With Electric Heat (unit sizes 006-020)**

kW	Unit Size						
	006	008	010	012	016	018	020
	Air Volume - CFM						
0.41	300	400	600	600	800	1000	1000
0.5	300	400	600	600	800	1000	1000
0.82	300	400	600	600	800	1000	1000
1	300	400	600	600	800	1000	1000
1.64	300	400	600	600	800	1000	1000
2	300	400	600	600	800	1000	1000
2.45	300	400	600	600	800	1000	1000
3	300	400	600	600	800	1000	1000
3.27	300	400	600	600	800	1000	1000
4	300	400	600	600	800	1000	1000
4.09	300	400	600	600	800	1000	1000
4.91	300	400	600	600	800	1000	1000
5	300	400	600	600	800	1000	1000
6	-	400	600	600	800	1000	1000
6.54	-	400	600	600	800	1000	1000
7.36	-	425	600	600	800	1000	1000
8	-	460	600	600	800	1000	1000
8.18	-	470	600	600	800	1000	1000
9	-	515	600	600	800	1000	1000
9.81	-	570	600	600	800	1000	1000
10	-	575	600	600	800	1000	1000
10.6	-	-	-	-	800	1000	1000
11	-	-	-	-	800	1000	1000
11.3	-	-	-	-	800	1000	1000
12	-	-	-	-	800	1000	1000
13	-	-	-	-	800	1000	1000

**Table 33: Horizontal Minimum Allowable Air Volume With Electric Heat (unit sizes 030-100)**

kW	Forward-Curved Fan Units			Plenum Fan Units					
	030	040	050	030	040	050	060	080	100
	Air Volume - CFM			Air Volume - CFM					
7.36	1500	2000	2500	1800	2400	3000	-	-	-
9	1500	2000	2500	1800	2400	3000	-	-	-
15	1500	2000	2500	1800	2400	3000	-	-	-
17	-	-	-	-	-	-	3600	-	-
18	1500	2000	2500	1800	2400	3000	-	-	-
19	-	-	-	-	-	-	3600	-	-
20	-	-	-	-	-	-	3600	-	-
21	1500	2000	2500	1800	2400	3000	-	-	-
24	1500	2000	2500	1800	2400	3000	-	-	-
25	-	-	-	-	-	-	-	4800	-
28.9	-	-	-	-	-	-	-	4800	6000
30	-	2000	2500	-	2400	3000	-	-	-
32	-	-	-	-	-	-	-	4800	6000
34.4	-	-	-	-	-	-	3600	-	-
36	-	2060	2500	-	2400	3000	-	-	-
38	-	-	-	-	-	-	3600	-	-
39	-	2250	2500	-	2400	3000	-	-	-
40	-	-	-	-	-	-	3600	-	-
43.4	-	-	-	-	-	-	-	4800	6000
48	-	-	-	-	-	-	-	4800	6000
50	-	-	-	-	-	-	-	4800	-
57	-	-	-	-	-	-	3600	4800	6000
60	-	-	-	-	-	-	3600	-	-
63	-	-	-	-	-	-	3603	4800	6000
65	-	-	-	-	-	-	-	4800	6000
75	-	-	-	-	-	-	4290	4800	-
95	-	-	-	-	-	-	5433	6000	6000
105	-	-	-	-	-	-	-	6005	-
133	-	-	-	-	-	-	-	-	7607

**Notes:** Limits are based on greater value of either:  
 1. 250 FPM face velocity across the electric heating coil  
 2. Entering Air of 70°F and a maximum of 125°F LAT

**Table 34: Vertical Minimum Allowable Air Volume With Electric Heat**

kW	Unit Size				
	006	008	012	016	020
	Air Volume - CFM				
0.82	300	-	-	-	-
1	300	400	-	-	-
1.64	-	400	600	-	-
2	300	400	600	800	1000
2.45	300	-	-	-	-
3	300	-	-	-	-
3.27	-	400	600	800	1000
4	300	400	600	800	1000
4.8	-	400	600	-	-
4.91	300	-	-	-	-
6	345	-	-	-	-
6.54	-	400	600	800	1000
8	-	460	600	800	1000
8.18	-	470	600	800	1000
9.6	-	550	600	800	1000
10	-	575	600	800	1000
12	-	-	-	800	1000
19.2	-	-	-	-	1100

kW	Forward-Curved Fan Units			Plenum Fan Units		
	030	040	050	030	040	050
	Air Volume - CFM			Air Volume - CFM		
6.8	1500	2000	2500	1800	2400	3000
9	1500	2000	2500	1800	2400	3000
11.3	1500	2000	2500	1800	2400	3000
13.5	1500	2000	2500	1800	2400	3000
15	1500	2000	2500	1800	2400	3000
18	1500	2000	2500	1800	2400	3000
21	1500	2000	2500	1800	2400	3000
24	1500	2000	2500	1800	2400	3000
39	2235	2235	2500	1800	2400	3000

**Notes:** Limits are based on greater value of either:  
 1. 250 FPM face velocity across the electric heating coil  
 2. Entering Air of 70°F and a maximum of 125°F LAT

**Table 35: Horizontal Electric Heat kW Options by Unit Size**

Unit Size	Voltage	Horizontal kW												
006	120/60/1	0.5	1.0	2.0	3.0	4.0	-	-	-	-	-	-	-	-
	208/60/1	0.4	0.8	1.6	2.5	3.3	4.1	4.9	-	-	-	-	-	-
	230/60/1	0.5	1.0	2.0	3.0	4.0	5.0	6.0	-	-	-	-	-	-
	277/60/1	-	1.0	2.0	3.0	4.0	5.0	6.0	-	-	-	-	-	-
008	120/60/1	0.5	1.0	2.0	3.0	4.0	5.0	-	-	-	-	-	-	-
	208/60/1	0.4	0.8	1.6	2.5	3.3	4.1	4.9	6.5	8.2	-	-	-	-
	230/60/1	0.5	1.0	2.0	3.0	4.0	5.0	6.0	8.0	-	10.0	-	-	-
	277/60/1	0.5	1.0	2.0	3.0	4.0	5.0	6.0	8.0	-	10.0	-	-	-
010	120/60/1	0.5	1.0	2.0	3.0	4.0	5.0	-	-	-	-	-	-	-
	208/60/1	0.4	0.8	1.6	2.5	3.3	4.1	4.9	6.5	8.2	-	-	-	-
	230/60/1	0.5	1.0	2.0	3.0	4.0	5.0	6.0	8.0	-	10.0	-	-	-
	277/60/1	0.5	1.0	2.0	3.0	4.0	5.0	6.0	8.0	-	10.0	-	-	-
012	120/60/1	0.5	1.0	2.0	3.0	4.0	5.0	-	-	-	-	-	-	-
	208/60/1	0.4	0.8	1.6	2.5	3.3	4.1	4.9	6.5	8.2	-	-	-	-
	230/60/1	0.5	1.0	2.0	3.0	4.0	5.0	6.0	8.0	-	10.0	-	-	-
	277/60/1	0.5	1.0	2.0	3.0	4.0	5.0	6.0	8.0	-	10.0	-	-	-
016	120/60/1	-	1.0	2.0	-	4.0	5.0	-	-	-	-	-	-	-
	208/60/1	-	0.8	1.6	-	3.3	-	4.9	6.5	8.2	-	-	-	-
	230/60/1	-	1.0	2.0	-	4.0	-	6.0	8.0	-	10.0	-	-	-
	277/60/1	-	1.0	2.0	-	4.0	-	6.0	8.0	-	10.0	-	12.0	13.0
018	120/60/1	-	-	-	-	4.0	-	-	8.0	-	10.0	12.0	16.0	20.0
	208/60/1	-	1.0	2.0	-	4.0	5.0	-	-	-	-	-	-	-
	230/60/1	-	0.8	1.6	-	3.3	-	4.9	6.5	8.2	9.0	-	-	-
	277/60/1	-	1.0	2.0	-	4.0	-	6.0	8.0	-	10.0	-	12.0	13.0
020	120/60/1	-	-	-	-	4.0	-	-	8.0	-	10.0	12.0	17.0	20.0
	208/60/1	-	1.0	2.0	-	4.0	5.0	-	-	-	-	-	-	-
	230/60/1	-	0.8	1.6	-	3.3	-	4.9	6.5	8.2	9.0	-	-	-
	277/60/1	-	1.0	2.0	-	4.0	-	6.0	8.0	-	10.0	-	12.0	13.0
030	208/60/3	6.8	11.3	13.5	-	-	-	-	-	-	-	-	-	-
	240/60/3	9.0	15.0	18.0	-	-	-	-	-	-	-	-	-	-
	460/60/3	9.0	15.0	18.0	21.0	24.0	-	-	-	-	-	-	-	-
	575/60/3	9.0	15.0	18.0	21.0	24.0	-	-	-	-	-	-	-	-
040	208/60/3	6.8	11.3	13.5	-	-	-	-	-	-	-	-	-	-
	240/60/3	9.0	15.0	18.0	-	-	-	-	-	-	-	-	-	-
	460/60/3	9.0	15.0	18.0	21.0	24.0	30.0	36.0	39.0	-	-	-	-	-
	575/60/3	9.0	15.0	18.0	21.0	24.0	30.0	36.0	39.0	-	-	-	-	-
050	208/60/3	6.8	11.3	13.5	-	-	-	-	-	-	-	-	-	-
	240/60/3	9.0	15.0	18.0	-	-	-	-	-	-	-	-	-	-
	460/60/3	9.0	15.0	18.0	21.0	24.0	30.0	36.0	39.0	-	-	-	-	-
	575/60/3	9.0	15.0	18.0	21.0	24.0	30.0	36.0	39.0	-	-	-	-	-
060	208/60/3	17.2	-	-	-	34.4	-	-	57	-	-	-	-	-
	240/60/3	19	-	-	-	38	-	-	63	-	-	-	-	-
	460/60/3	-	20	-	-	-	40	-	63	-	75	-	-	-
	575/60/3	-	20	-	-	-	40	-	63	-	75	-	-	-
080	208/60/3	-	-	-	28.9	-	-	43.4	57	-	-	-	-	-
	240/60/3	-	-	-	32	-	-	48	63	-	-	-	-	-
	460/60/3	-	-	25	-	-	-	50	-	-	75	-	105	-
	575/60/3	-	-	25	-	-	-	50	-	-	-	95	105	-
100	208/60/3	-	-	-	28.9	-	-	43.4	57	-	-	-	-	-
	240/60/3	-	-	-	32	-	-	48	63	-	-	-	-	-
	460/60/3	-	-	-	32	-	-	-	-	65	-	95	-	133
	575/60/3	-	-	-	32	-	-	-	-	65	-	95	-	133

**Table 36: Vertical Electric Heat kW Options by Unit Size**

Unit Size	Voltage	Vertical kW												
006	120/60/1	-	1	2	-	4	-	-	-	-	-	-	-	-
	208/60/1	-	0.8	-	2.5	3.3	-	4.9	-	-	-	-	-	-
	230/60/1	-	1.0	-	3.0	4.0	-	6.0	-	-	-	-	-	-
	277/60/1	-	1.0	-	3.0	4.0	-	6.0	-	-	-	-	-	-
	460/60/1	-	1.0	-	3.0	-	-	6.0	-	-	-	-	-	-
008	120/60/1	-	1.0	2.0	-	4.0	-	-	-	-	-	-	-	-
	208/60/1	-	-	1.6	-	3.3	-	-	6.5	8.2	-	-	-	-
	230/60/1	-	-	2.0	-	4.0	-	-	8.0	-	10.0	-	-	-
	277/60/1	-	-	2.0	-	4.0	-	-	8.0	-	10.0	-	-	-
	460/60/1	-	-	2.0	-	4.0	5.0	-	8.0	-	10.0	-	-	-
012	120/60/1	-	-	2.0	-	4.0	-	-	-	-	-	-	-	-
	208/60/1	-	-	1.6	-	3.3	-	-	6.5	8.2	-	-	-	-
	230/60/1	-	-	2.0	-	4.0	-	-	8.0	-	10.0	-	-	-
	277/60/1	-	-	2.0	-	4.0	-	-	8.0	-	10.0	-	-	-
	460/60/1	-	-	2.0	-	4.0	5.0	-	8.0	-	10.0	-	-	-
016	120/60/1	-	-	2.0	-	4.0	-	-	-	-	-	-	-	-
	208/60/1	-	-	-	-	3.3	-	-	6.5	8.2	-	-	-	-
	230/60/1	-	-	-	-	4.0	-	-	8.0	-	10.0	-	-	-
	277/60/1	-	-	-	-	4.0	-	-	8.0	-	10.0	12.0	-	-
	460/60/1	-	-	-	-	4.0	-	-	8.0	-	10.0	12.0	-	-
020	120/60/1	-	-	2.0	-	4.0	-	-	-	-	-	-	-	-
	208/60/1	-	-	-	-	3.3	-	-	6.5	8.2	-	-	-	-
	230/60/1	-	-	-	-	4.0	-	-	8.0	-	10.0	-	-	-
	277/60/1	-	-	-	-	4.0	-	-	8.0	-	10.0	12.0	-	-
	460/60/1	-	-	-	-	4.0	-	-	8.0	-	10.0	12.0	-	20.0
030	208/60/3	6.8	11.3	13.5	-	-	-	-	-	-	-	-	-	-
	240/60/3	9.0	15.0	18.0	-	-	-	-	-	-	-	-	-	-
	460/60/3	9.0	15.0	-	21.0	24.0	-	-	-	-	-	-	-	-
	575/60/3	9.0	15.0	-	21.0	24.0	-	-	-	-	-	-	-	-
040	208/60/3	6.8	11.3	13.5	-	-	-	-	-	-	-	-	-	-
	240/60/3	9.0	15.0	18.0	-	-	-	-	-	-	-	-	-	-
	460/60/3	9.0	15.0	-	21.0	24.0	-	-	39.0	-	-	-	-	-
	575/60/3	9.0	15.0	-	21.0	24.0	-	-	39.0	-	-	-	-	-
050	208/60/3	6.8	11.3	13.5	-	-	-	-	-	-	-	-	-	-
	240/60/3	9.0	15.0	18.0	-	-	-	-	-	-	-	-	-	-
	460/60/3	9.0	15.0	-	21.0	24.0	-	-	39.0	-	-	-	-	-
	575/60/3	9.0	15.0	18.0	21.0	24.0	-	-	39.0	-	-	-	-	-

**Table 37: Horizontal Unit - Heater Amps**

Horizontal Heater Amps											
kW	120V / 1Ø	230V / 1Ø	277V / 1Ø	460V / 1Ø	kW	240V / 3Ø	460V / 3Ø	575V / 3Ø	kW	208V/1Ø†	208V/3Ø†
0.5	4.17	2.17	1.81	-	0.5	1.20	0.63	0.50	0.41	1.97	-
1	8.33	4.35	3.61	2.17	1	2.41	1.26	1.00	0.82	3.94	-
2	16.67	8.70	7.22	4.35	2	4.81	2.51	2.01	1.64	7.88	-
3	25.00	13.04	10.83	6.52	3	7.22	3.77	3.01	2.45	11.78	-
4	33.33	17.39	14.44	8.70	4	9.62	5.02	4.02	3.27	15.72	-
5	41.67	21.74	18.05	10.87	5	12.03	6.28	5.02	4.09	19.66	-
6	-	26.09	21.66	13.04	6	14.43	7.53	6.02	4.91	23.61	-
8	-	34.78	28.88	17.39	8	19.25	10.04	8.03	6.54	31.44	-
10	-	43.48	-	21.74	9	21.65	11.30	9.04	6.80	-	35.38
11	-	47.83	39.71	-	10	24.06	12.55	10.04	8.18	39.33	-
12	-	-	43.32	26.09	11	26.46	13.81	11.04	9.00	43.27	-
13	-	-	46.93	-	12	28.87	15.06	12.05	9.81	47.16	-
18	-	-	-	39.13	13	31.27	16.32	13.05	10.63	51.11	-
21	-	-	-	45.65	15	36.08	18.83	15.06	11.30	-	54.33
					18	43.30	22.59	18.07	13.50	-	64.90
					19	45.70	-	-	17.2	-	47.70
					20	-	24.10	19.20	28.9	-	80.30
					21	-	26.36	21.09	34.4	-	95.40
					24	-	30.12	24.10	43.4	-	120.50
					25	-	30.10	-	57	-	158.10
					30	-	37.65	30.12			
					36	-	45.18	36.15			
					39	-	48.95	39.16			
					40	-	48.1	38.5			
					48	115.5	-	-			
					50	-	60.1	-			
					60	-	72.2	57.7			
					63	151.6	-	-			
					65	-	-	62.5			
					75	-	90.2	72.2			
					95	-	-	91.4			
					105	-	126.3	1.1			
					133	-	160	128			

**Note:** † Indicates that 208V single and three phase applications make use of a de-rated 230/240V heater.

**Table 38: Vertical Unit - Heater Amps**

Vertical Heater Amps											
kW	115V / 1Ø	230V / 1Ø	277V / 1Ø	480V / 1Ø	kW	240V / 3Ø	480V / 3Ø	600V / 3Ø	kW	208V / 1Ø†	208V / 3Ø†
1	8.7	4.3	3.6	2.1	9	21.7	10.8	8.7	0.82	3.9	-
2	17.4	8.7	7.2	4.2	15	36.1	18.0	14.4	1.64	7.9	-
3	-	13.0	10.8	6.3	18	43.3	-	-	2.45	11.8	-
4	34.8	17.4	14.4	8.3	21	-	25.3	20.2	3.27	15.7	-
5	-	-	-	10.87	24	-	28.9	23.1	4.09	19.7	-
6	-	26.1	21.7	12.5	39	-	46.9	37.5	4.91	23.6	-
8	-	34.8	28.9	16.7					6.54	31.5	-
10	-	43.5	36.1	20.83					6.80	-	18.8
12	-	-	43.3	25.0					8.18	39.3	-
19.2	-	-	-	40.0					11.3	-	31.3
									13.5	-	37.5

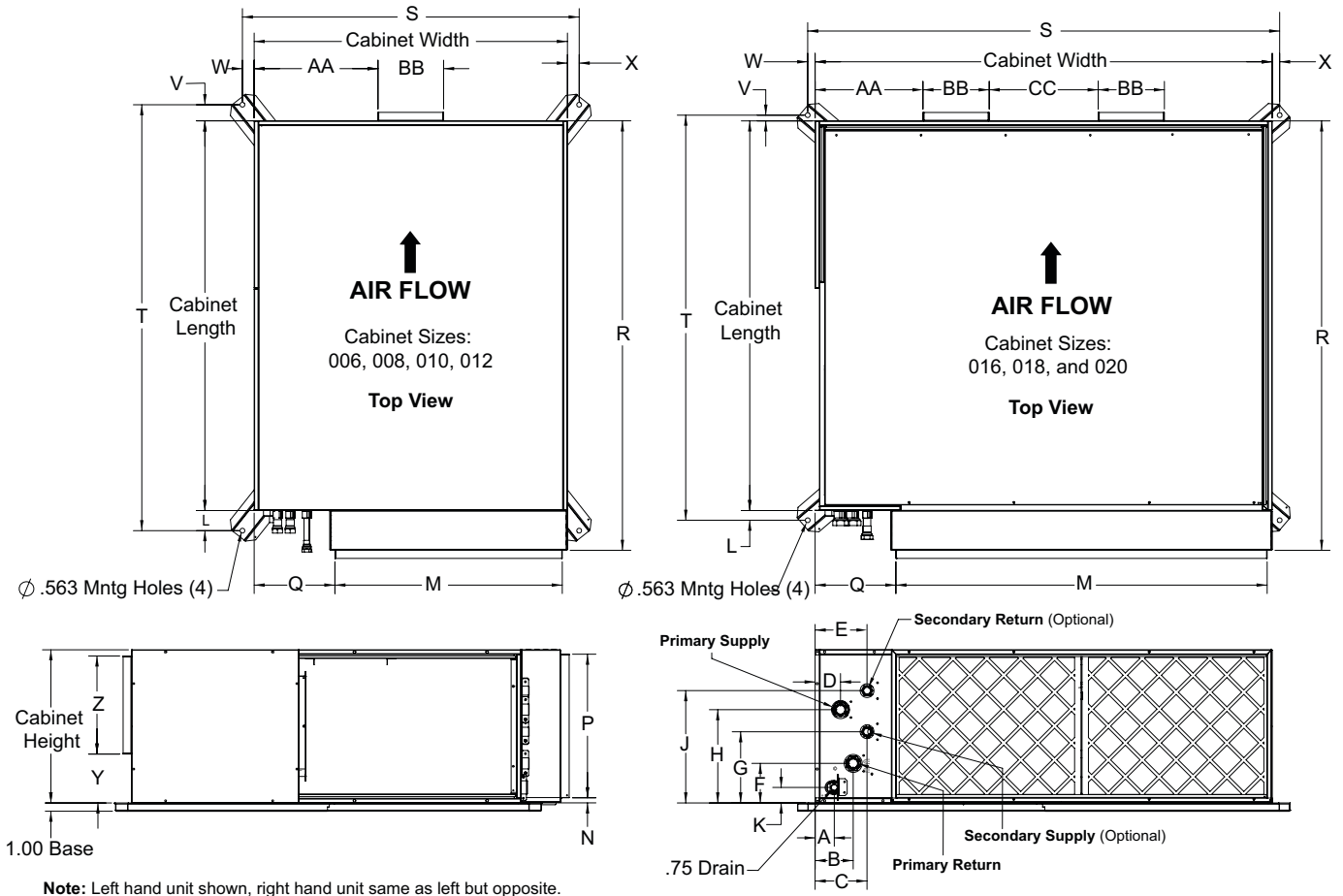
**Note:** † Indicates that 208V single and three phase applications make use of a de-rated 230/240V heater.



# Dimensional Data

## Size 006-050 Horizontal Unit Dimensions

Figure 40: Left-Hand, Single and Dual Fan (Sizes 006-020)



Note: Left hand unit shown, right hand unit same as left but opposite.

- Overall Cabinet Dimensions**
- 006 = 43L x 24W x 18H
  - 008 = 43L x 29W x 18H
  - 010 & 012 = 46L x 37W x 18H
  - 016 = 46L x 45.5W x 18H
  - 018 & 020 = 46L x 54W x 18H

**Table 39: Dimension Letter Reference for Figure 40 on page 52**

Dimension	006	008	010	012	016	018	020
<b>A</b>	2.26	2.28	2.18	2.18	2.60	2.25	2.25
<b>B</b>	4.01	4.51	4.26	4.26	4.52	4.50	4.50
<b>C</b>	5.75	6.45	6.24	6.24	6.15	6.19	6.19
<b>D</b>	2.51	3.00	2.76	2.76	3.02	3.00	3.00
<b>E</b>	5.75	6.42	6.24	6.24	6.15	6.15	6.15
<b>F</b>	5.45	5.42	4.67	4.67	4.67	4.67	4.67
<b>G</b>	7.42	7.40	8.13	8.13	8.38	8.38	8.38
<b>H</b>	11.03	10.77	11.15	11.15	11.03	11.03	11.03
<b>J</b>	13.85	13.32	13.26	13.26	13.27	13.27	13.27
<b>K</b>	1.83	1.80	1.83	1.83	1.83	1.83	1.83
<b>L</b>	1.70	1.38	2.42	2.42	1.79	1.18	1.18
<b>M</b>	11.61	16.61	26.87	26.87	35.27	43.87	43.87
<b>N</b>	0.67	0.59	0.60	0.60	0.60	0.60	0.60
<b>P</b>	16.97	16.97	16.97	16.97	16.97	16.97	16.97
<b>Q</b>	9.56	9.53	9.53	9.53	9.63	10.67	10.67
<b>R</b> Bottom Access	47.70	47.70	50.70	50.70	50.70	50.70	50.70
<b>R</b> Side Access	49.50	49.50	53.90	53.90	52.50	52.50	52.50
<b>S</b>	24.79	29.77	39.80	39.80	47.89	55.80	55.80
<b>T</b>	45.90	45.25	50.34	50.34	48.97	47.87	47.87
<b>V</b>	1.19	0.87	1.90	1.90	1.23	0.67	0.67
<b>W</b>	0.38	0.38	1.39	1.39	1.19	0.87	0.87
<b>X</b>	0.38	0.38	1.39	1.39	1.19	0.87	0.87
<b>Y</b>	5.77	5.77	5.77	5.77	5.77	5.77	5.77
<b>Z</b>	11.59	11.59	11.59	11.59	11.59	11.59	11.59
<b>AA</b>	8.13	10.63	14.63	14.63	9.24	12.74	12.74
<b>BB</b>	7.73	7.75	7.75	7.75	7.75	7.82	7.82
<b>CC</b>	0.00	0.00	0.00	0.00	11.53	12.88	12.88

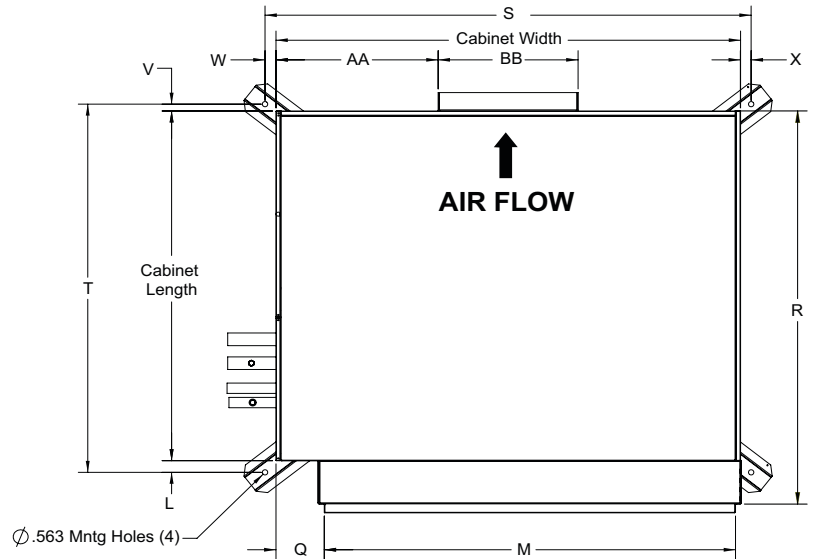
Figure 41: Left-Hand, Single Fan (Sizes 030-050)

**Notes:**

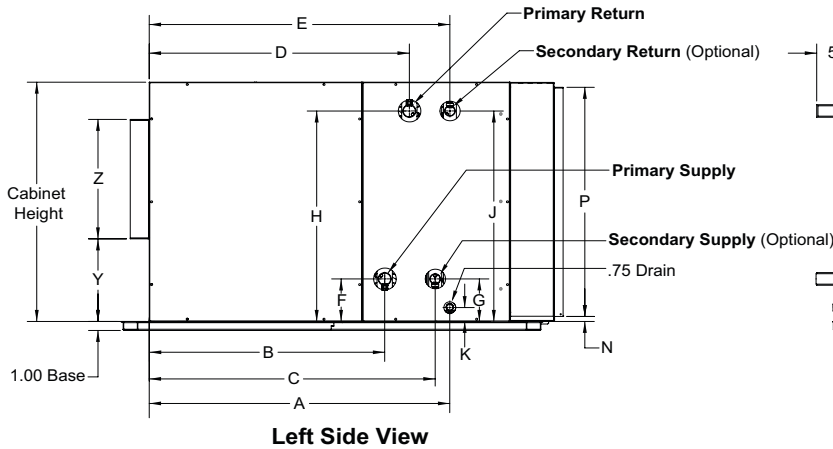
1. Refer to submittal drawings in Daikin SelectTools for piping connection dimensions.
2. Left hand unit shown, right hand unit values same as left but opposite.
3. Preheat option shown, reheat option viable.

**Overall Cabinet Dimensions**

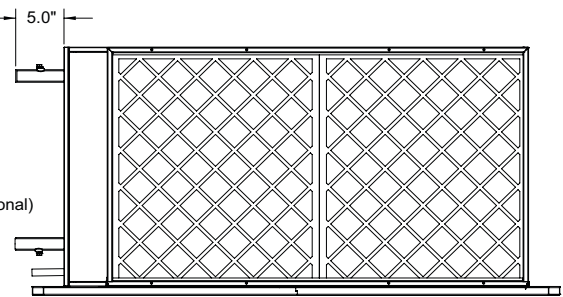
- 030 = 38L × 49W × 26H (forward-curved fan units)
- 030 = 39.5L × 49W × 26H (plenum fan units)
- 040 = 41L × 54W × 30H
- 050 = 41L × 61W × 32H



Top View



Left Side View



Front View

Table 40: Dimension Letter Reference for Hanger Brackets

Dimension	030	040	050
R Bottom Access	42.65	45.72	45.66
R Side Access	44.40	47.40	47.40
L	1.26	1.16	0.87
S	51.23	56.02	62.59
T	40.01	42.80	42.22
V	0.74	0.63	0.35
W	1.15	1.01	0.80
X	1.12	1.01	0.80

**Table 41: Hydronic Unit Dimensions - Dimension Letter Reference for Figure 41 on page 54**

Unit Size		2-Row Cooling / Primary					4-Row Cooling / Primary					6-Row Cooling / Primary					8-Row Cooling / Primary
		Preheat		Reheat			Preheat		Reheat			Preheat		Reheat			
		1-Row	2-Row	1-Row	2-Row		1-Row	2-Row	1-Row	2-Row		1-Row	2-Row	1-Row	2-Row		
030	A	32.12	32	32	32	32	32.12	32	32	32	32	32.12	32	32	32	32	32.12
	B	24	24	24	24	24	24	24	24	24	24	24.81	24.81	24.81	24	24	24.81
	C	-	30.13	30.13	28.12	28.12	-	30.13	30.13	28.12	28.12	30.13	30.13	30.13	29	29	-
	D	25.5	25.5	26.56	25.12	25.12	26.5	26.56	26.56	25.12	25.12	27.43	27.41	27.41	25.12	25.12	29.16
	E	-	31.5	31.5	29.62	29.62	-	31.5	31.5	30.69	30.69	-	31.5	31.5	31.5	31.5	-
	G	-	4.62	4.62	4.62	4.62	-	4.62	4.62	4.62	4.62	4.62	4.62	4.62	4.62	4.62	-
	J	-	22.86	22.86	22.86	22.86	-	22.86	22.86	22.86	22.86	-	22.86	22.86	22.86	22.86	-
040	A	35.12	35.12	35.12	35.12	35.12	35.12	35.12	35.12	35.12	35.12	35.12	35.12	35.12	35.12	35.12	35.12
	B	27	27	27	27	27	27.87	27.87	27.87	27	27	27.83	27.87	37.87	27	27	27.83
	C	-	33.12	33.12	31.12	33.12	-	33.12	33.12	32	31.12	33.15	33.12	33.12	32	32	-
	D	28.5	28.5	28.5	28.5	28.5	30.43	30.5	30.5	28.5	28.5	30.43	30.5	30.5	28.25	28.25	32.16
	E	-	34.5	34.5	32.67	34.5	-	34.5	34.5	34.62	32.62	-	34.5	34.5	34.62	34.62	-
	G	-	4.62	4.62	4.62	4.62	-	4.62	4.62	4.62	4.62	4.62	4.62	4.62	4.62	4.62	-
	J	-	26.87	26.87	26.87	26.87	-	26.87	26.87	26.87	26.87	-	26.87	26.87	26.87	26.87	-
050	A	35.12	35.12	35.12	35.12	35.12	35.12	35.12	35.12	35.12	35.12	35.12	35.12	35.12	35.12	35.12	35.12
	B	27	27	27	27.68	27.68	27.12	27	27	27.68	27.68	27.81	27.87	27.87	27.75	27.75	27.79
	C	-	33.87	33.87	31.12	31.12	-	33.87	33.87	31.25	31.25	33.1	33.82	33.82	33.87	33.87	-
	D	28.86	29	29	29.12	29.12	29.68	29.68	29.68	29.12	29.12	30.41	30.37	30.37	30.43	30.43	32.12
	E	-	35.44	35.44	33	33	-	35.31	35.31	33.82	33.82	-	35.25	35.25	35.31	35.31	-
	G	-	4.62	4.62	4.62	4.62	-	4.62	4.62	4.62	4.62	4.74	4.62	4.62	4.62	4.62	-
	J	-	28.87	28.87	28.87	28.87	-	28.87	28.87	28.87	28.87	-	28.87	28.87	28.87	28.87	-

**Table 42: Hydronic Unit Dimensions - Dimension Letter Reference for Figure 41 on page 54**

Dimension	Unit Size		
	030	040	050
F	4.62	4.62	4.62
H	22.86	26.87	28.87
K	1.61	1.61	1.61
M	43.34	48.45	54.96
N	0.57	0.55	0.55
P	24.9	28.92	30.94
Q	5.08	5.01	5.5
Y (FC Fans)	9.73	9.51	10.25
Y (Plenum Fans)	4.94	7.97	6.95
Z (FC Fans)	11.47	13.53	13.53
Z (Plenum Fans)	27.13	14.06	18.13
AA (FC Fans)	23.35	22.64	22.64
AA (Plenum Fans)	10.93	6.47	10.43
BB (FC Fans)	13.21	15.62	15.62
BB (Plenum Fans)	16.13	41.06	40.13

**Table 43: DX Unit Dimensions - Dimension Letter Reference for Figure 41 on page 54**

Unit Size		Single Circuit DX						Interlaced DX			
		Dimension	Preheat		Reheat		24.38	Preheat		Reheat	
			1-Row	2-Row	1-Row	2-Row		1-Row	2-Row	1-Row	2-Row
030	B	25.69	25.69	25.61	23.95	23.88	24.38	24.3	24.3	23.88	23.88
	C	-	30.16	30.07	29.83	29.76	25.7	30.07	30.07	28.45	28.45
	D	-	-	-	25.04	25.42	-	25.62	25.61	25.09	25.43
	E	-	31.24	31.61	-	-	-	31.28	31.61	29.76	29.76
	F	4.35	4.35	4.35	4.61	4.62	5.35	5.35	5.35	4.61	4.62
	G	-	4.62	4.65	4.35	4.35	9.35	4.62	4.62	5.35	5.35
	H	-	-	-	22.86	22.87	-	9.35	9.35	22.86	22.87
040	J	-	22.87	22.87	-	-	-	22.87	22.87	9.35	9.35
	B	28.71	28.69	28.7	26.97	26.97	27.27	27.26	27.26	26.97	26.97
	C	-	33.16	33.16	32.85	32.85	28.7	33.16	33.16	31.41	31.41
	D	-	-	-	28.29	28.52	-	28.7	28.7	28.29	28.52
	E	-	34.48	34.7	-	-	-	34.48	34.7	32.85	32.85
	F	4.35	4.35	4.35	5.65	4.62	5.35	5.35	5.35	5.62	4.62
	G	-	5.62	4.62	4.39	4.35	9.35	5.62	4.62	5.35	5.35
050	H	-	-	-	25.38	26.87	-	9.35	9.35	25.37	26.87
	J	-	25.37	26.87	-	-	-	25.37	26.87	9.35	9.35
	B	28.69	28.69	28.68	27.68	26.9	27.13	27.13	27.12	27.68	26.9
	C	-	33.87	33.09	32.84	32.83	30.25	33.87	33.09	31.27	31.26
	D	-	-	-	29.13	29.24	-	30.25	30.24	29.13	29.24
	E	-	35.32	35.43	-	-	-	35.32	35.43	34.4	34.39
	F	4.35	4.35	4.35	4.62	4.62	5.35	5.35	5.35	4.62	4.62
050	G	-	4.62	4.62	4.35	4.35	7.35	4.62	4.62	5.35	5.35
	H	-	-	-	28.87	28.87	-	7.35	7.35	28.87	28.87
	J	-	28.87	28.87	-	-	-	28.87	28.87	7.35	7.35

**Table 44: DX Unit Dimensions - Dimension Letter Reference for Figure 41 on page 54**

Dimension	Unit Size		
	030	040	050
A	32.1	35.1	35.1
K	1.61	1.61	1.61
M	43.34	48.45	54.96
N	0.57	0.55	0.55
P	24.9	28.92	30.94
Q	5.08	5.01	5.50
Y (FC Fans)	9.73	9.51	10.25
Y (Plenum Fans)	4.94	7.97	6.95
Z (FC Fans)	11.47	13.53	13.53
Z (Plenum Fans)	27.13	14.06	18.13
AA (FC Fans)	23.35	22.64	22.64
AA (Plenum Fans)	10.93	6.47	10.43
BB (FC Fans)	13.21	15.62	15.62
BB (Plenum Fans)	16.13	41.06	40.13

Figure 42: Horizontal Mixing Box – Top and End Damper, Left Hand Sizes 006–020 and Right Hand Sizes 030–050 – Side Filter Access

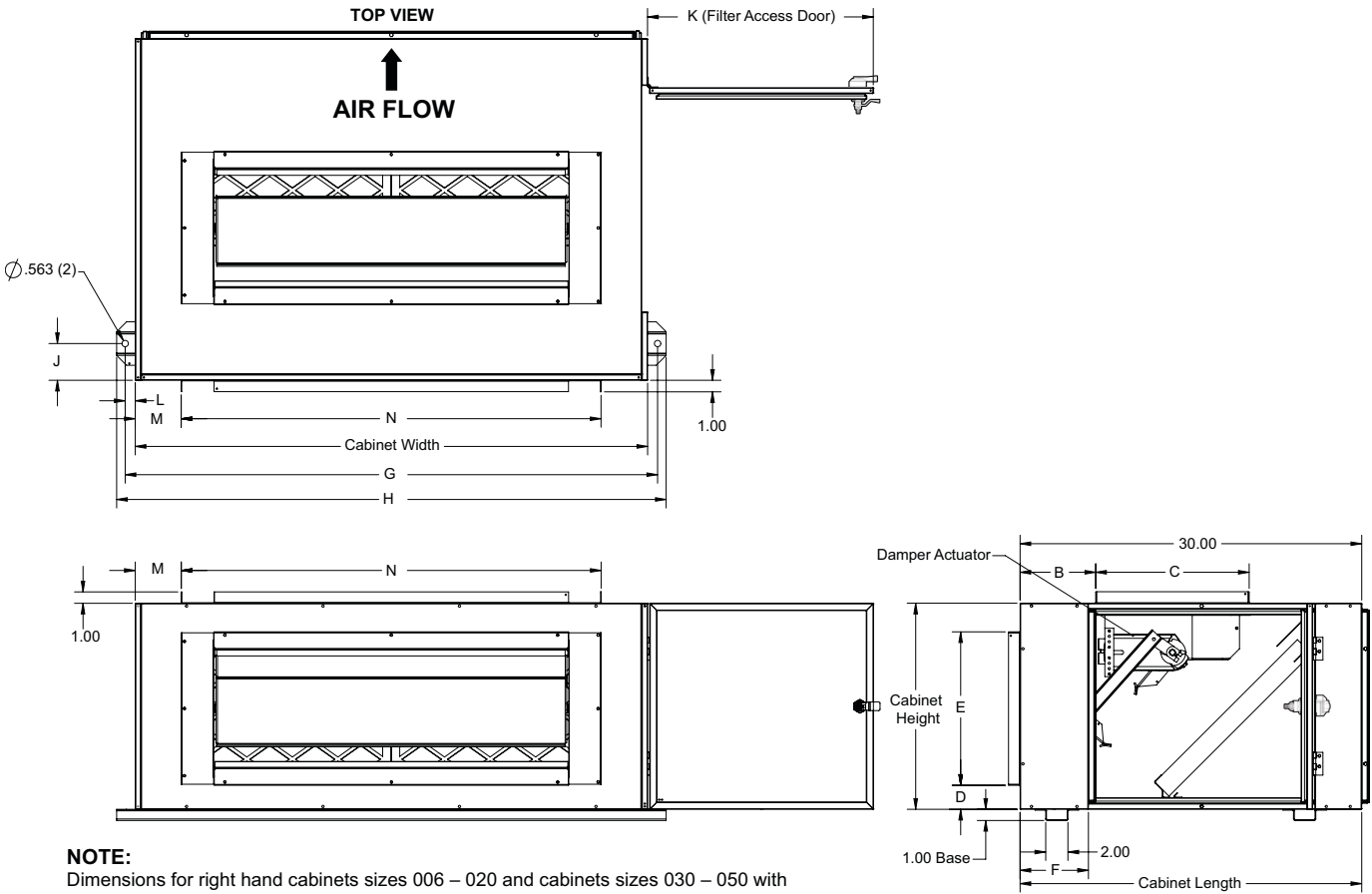


Table 45: Mixing Box Dimension Letter Reference

Cabinet	006	008	010	012	016	018	020	030	040	050
B	6.64	6.64	6.64	6.64	6.64	6.64	6.64	5.54	5.54	5.54
C	13.47	13.47	13.47	13.47	13.47	13.47	13.47	18.39	18.39	18.39
D	2.11	2.11	2.11	2.11	2.11	2.11	2.11	3.80	5.80	6.80
E	13.47	13.47	13.47	13.47	13.47	13.47	13.47	18.39	18.39	18.39
F	6.12	6.12	6.12	6.12	6.12	6.12	6.12	14.06	14.06	14.06
G	16.75	21.75	29.75	29.75	38.25	46.75	46.75	51.00	56.00	63.00
H	18.25	23.25	31.25	31.25	39.75	48.25	48.25	52.50	57.50	64.50
J	3.22	3.22	3.22	3.22	3.22	3.22	3.22	3.22	3.22	3.22
K	19.75	19.75	19.75	19.75	19.75	19.75	19.75	14.75	14.75	14.75
L	0.87	0.87	0.87	0.87	0.87	0.87	0.87	1.00	1.00	1.00
M	0.98	2.66	2.29	2.29	2.80	4.04	4.04	6.32	3.82	2.82
N	10.18	14.66	23.41	30.90	30.90	36.87	36.87	36.34	46.34	55.34



Figure 43: Horizontal Mixing Box – Bottom and End Damper, Left Hand Sizes 006–020 and Right Hand Sizes 030–050 – Side Filter Access

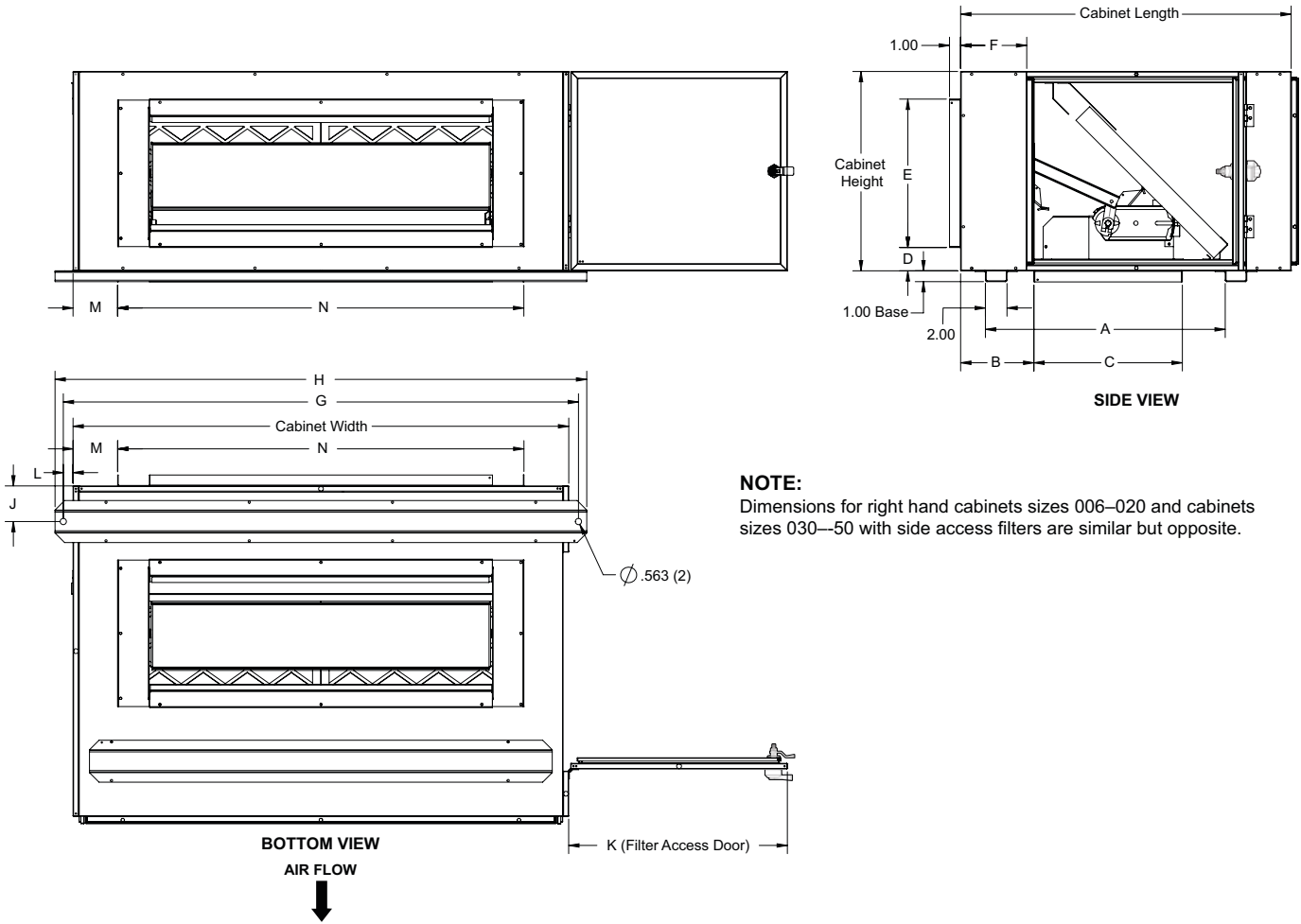


Table 46: Mixing Box Dimension Letter Reference

Cabinet	006	008	010	012	016	018	020	030	040	050
A	20.51	20.51	20.51	20.51	20.51	20.51	20.51	27.27	27.27	27.27
B	6.64	6.64	6.64	6.64	6.64	6.64	6.64	5.54	5.54	5.54
C	13.47	13.47	13.47	13.47	13.47	13.47	13.47	18.39	18.39	18.39
D	2.11	2.11	2.11	2.11	2.11	2.11	2.11	3.80	5.80	6.80
E	13.47	13.47	13.47	13.47	13.47	13.47	13.47	18.39	18.39	18.39
F	6.12	6.12	6.12	6.12	6.12	6.12	6.12	14.06	14.06	14.06
G	16.75	21.75	29.75	29.75	38.25	46.75	46.75	51.00	56.00	63.00
H	18.25	23.25	31.25	31.25	39.75	48.25	48.25	52.50	57.50	64.50
J	3.22	3.22	3.22	3.22	3.22	3.22	3.22	3.22	3.22	3.22
K	19.75	19.75	19.75	19.75	19.75	19.75	19.75	14.75	14.75	14.75
L	0.87	0.87	0.87	0.87	0.87	0.87	0.87	1.00	1.00	1.00
M	0.98	2.66	2.29	2.29	2.80	4.04	4.04	6.32	3.82	2.82
N	10.18	14.66	23.41	30.90	30.90	36.87	36.87	36.34	46.34	55.34

Figure 44: Horizontal Mixing Box Dimensions – Left Hand Sizes 006–020 and Right Hand Sizes 030–050 – Bottom Filter Access

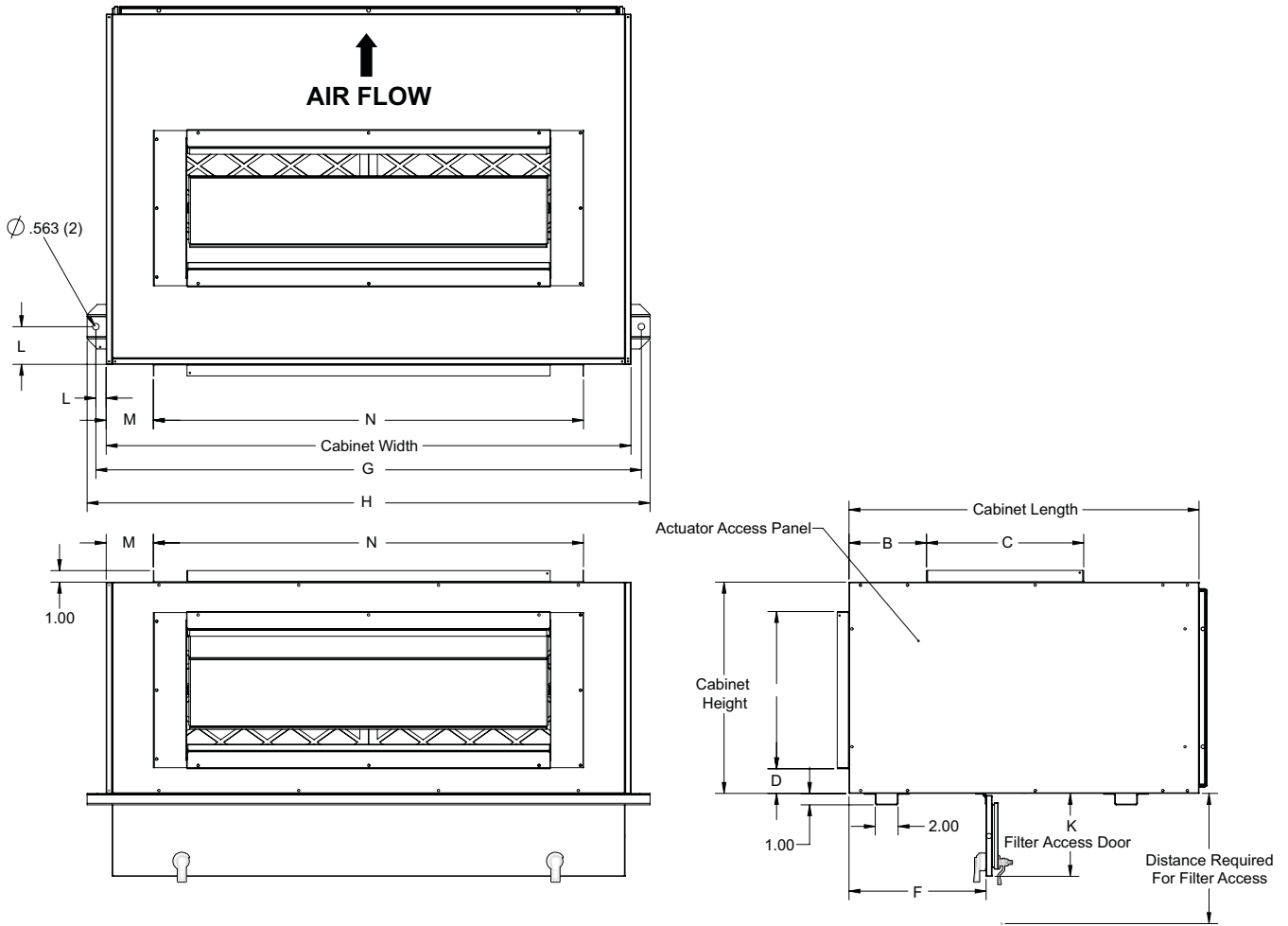


Table 47: Mixing Box Dimension Letter Reference

Cabinet	006	008	010	012	016	018	020	030	040	050
B	6.64	6.64	6.64	6.64	6.64	6.64	6.64	5.54	5.54	5.54
C	13.47	13.47	13.47	13.47	13.47	13.47	13.47	18.39	18.39	18.39
D	2.11	2.11	2.11	2.11	2.11	2.11	2.11	3.80	5.80	6.80
E	13.47	13.47	13.47	13.47	13.47	13.47	13.47	18.39	18.39	18.39
F	11.62	11.62	11.62	11.62	11.62	11.62	11.62	19.56	17.86	17.36
G	16.75	21.75	29.75	29.75	38.25	46.75	46.75	51.00	56.00	63.00
H	18.25	23.25	31.25	31.25	39.75	48.25	48.25	52.50	57.50	64.50
J	3.22	3.22	3.22	3.22	3.22	3.22	3.22	3.22	3.22	3.22
K	7.00	7.00	7.00	7.00	7.00	7.00	7.00	7.00	7.00	7.00
L	0.87	0.87	0.87	0.87	0.87	0.87	0.87	1.00	1.00	1.00
M	0.98	2.66	2.29	2.29	2.80	4.04	4.04	6.32	3.82	2.82
N	10.18	14.66	23.41	30.90	30.90	36.87	36.87	36.34	46.34	55.34

Figure 45: Horizontal Discharge Plenum (Sizes 006-050)

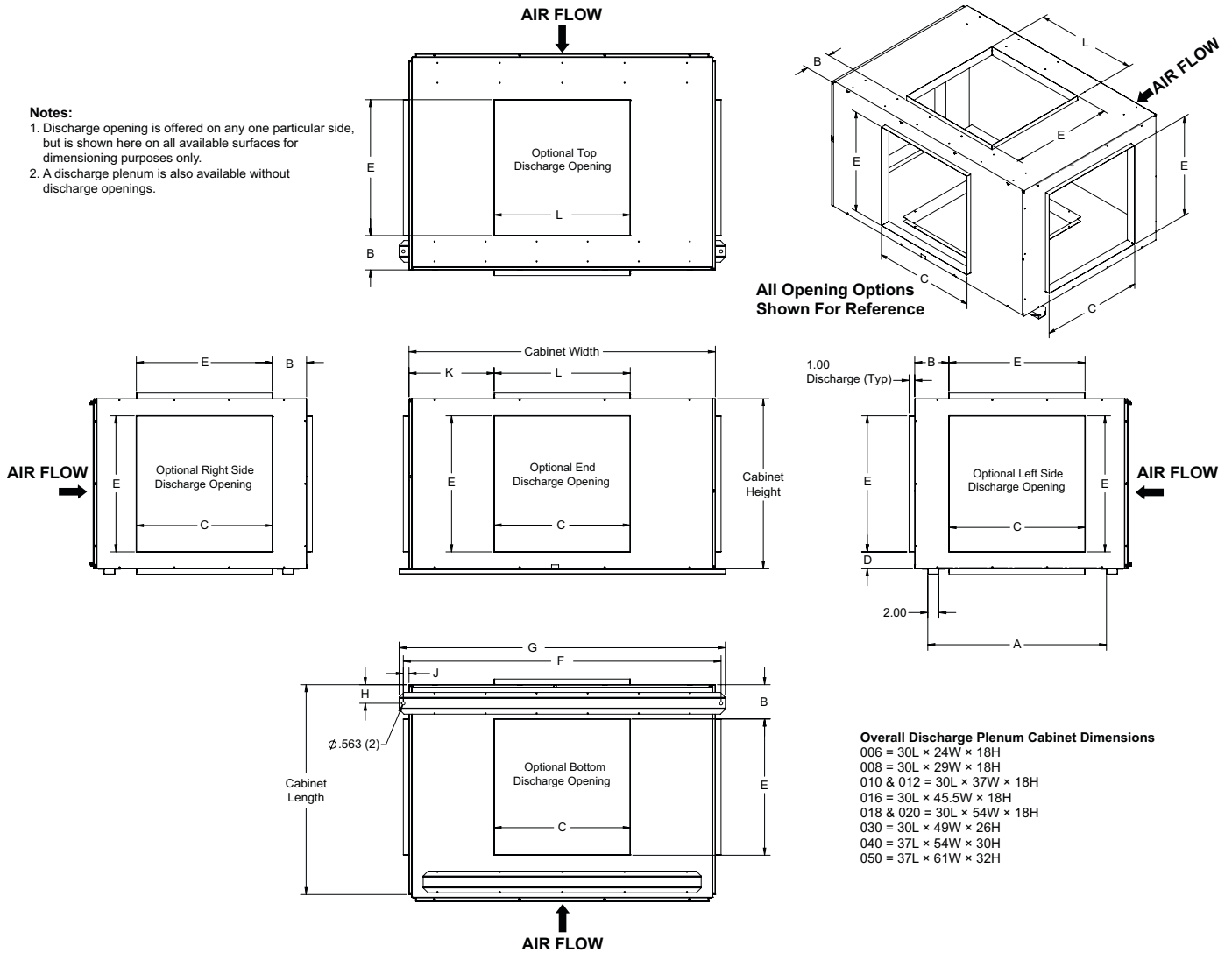


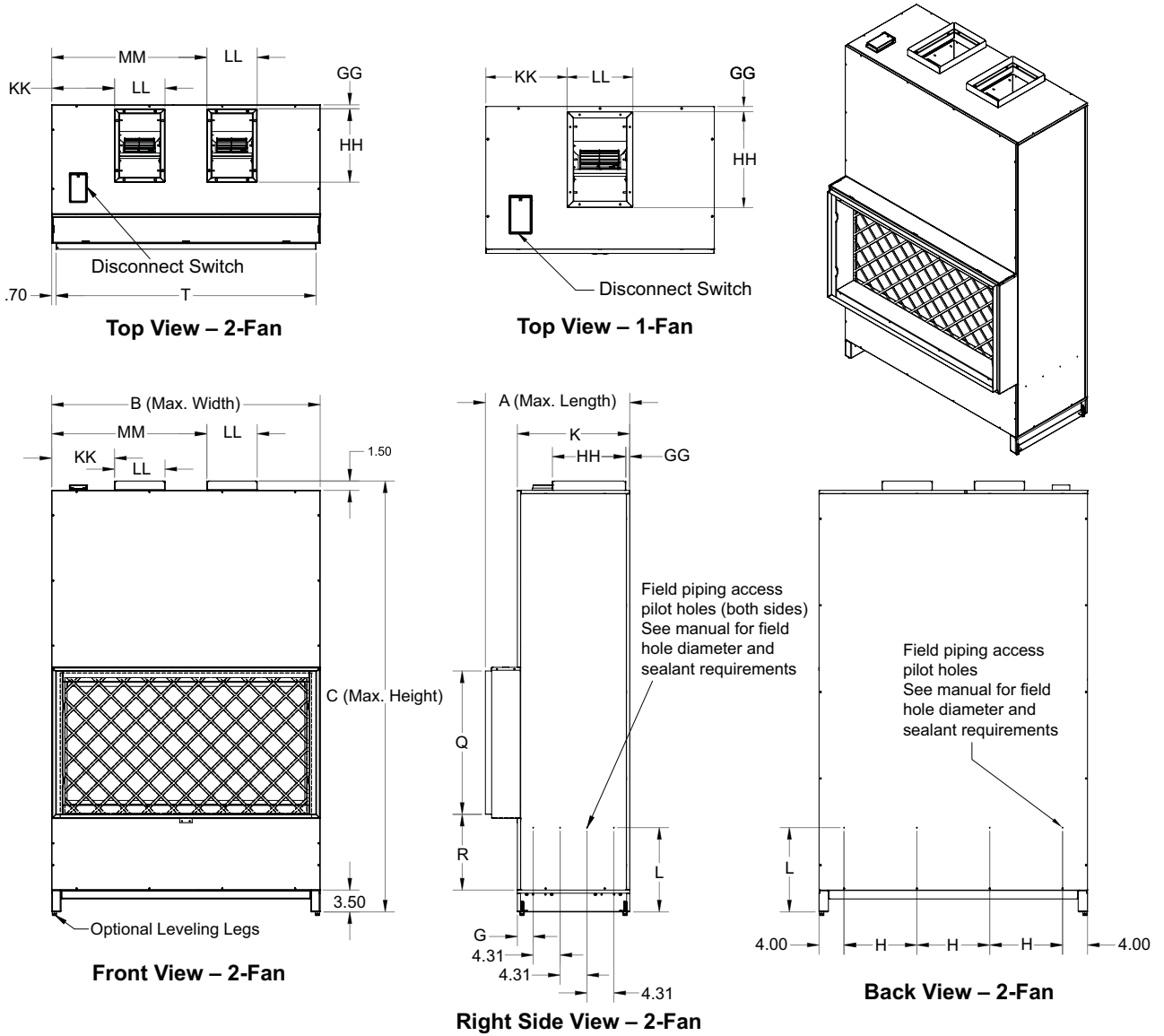
Table 48: Discharge Plenum Dimension Letter Reference

Cabinet	006	008	010	012	016	018	020	030	040	050
A	22.00	22.00	22.00	22.00	22.00	22.00	22.00	24.50	31.50	32.88
B	6.56	6.10	6.56	6.56	6.56	6.56	6.56	5.53	6.02	5.06
C	12.00	12.00	14.00	14.00	16.00	20.00	20.00	24.00	24.00	28.00
D	5.00	3.00	2.00	2.00	2.00	2.00	2.00	3.00	3.00	2.00
E	8.00	12.00	14.00	14.00	14.00	14.00	14.00	20.00	24.00	28.00
F	26.00	30.00	39.00	39.00	48.00	56.00	56.00	50.50	56.00	62.50
G	27.50	31.50	40.50	40.50	49.50	57.50	57.50	52.00	57.50	64.00
H	3.25	3.25	3.25	3.25	3.25	3.25	3.25	3.25	3.25	2.63
J	1.00	0.50	1.00	1.00	1.25	1.00	1.00	0.75	1.00	0.75
K	6.00	8.50	11.50	11.50	14.75	17.00	17.00	12.50	15.00	16.50
L	12.00	12.00	14.00	14.00	16.00	20.00	20.00	24.00	24.00	28.00

NOTE: Discharge opening is offered on any one particular side, but is shown here on all available surfaces for dimensioning purposes only. A discharge plenum is also available without discharge openings.

# Size 006-050 Vertical Unit Dimensions

Figure 46: Left-Hand, Single and Dual Fan (Sizes 006-020)

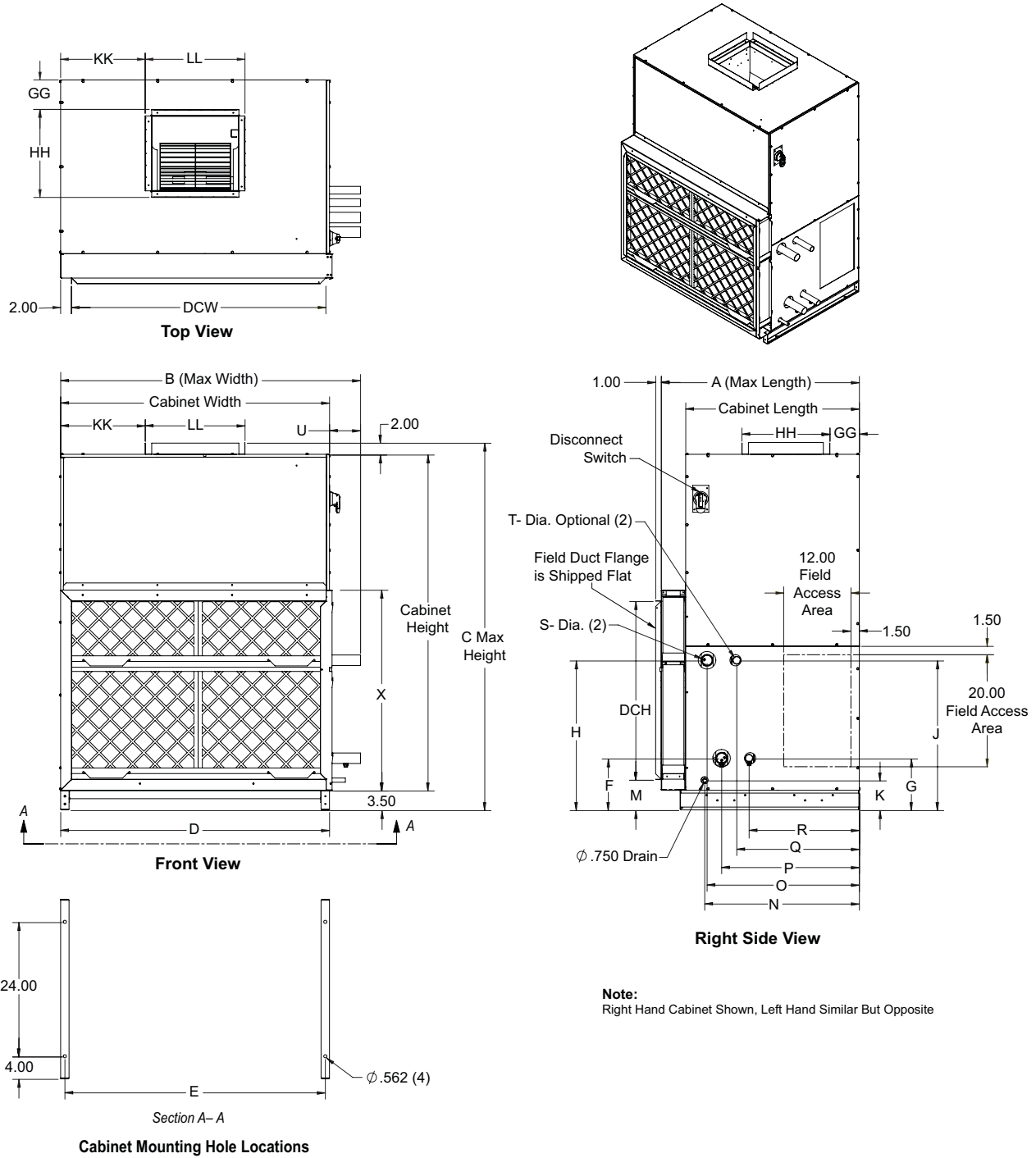


Note: Sizes 006 - 012 have 1 outlet while sizes 016-020 have 2

Table 49: Dimension Letter Reference

Size	Internal Filter																			
	A	B	C	G	H	K	L	Q	R	S	U	V	W	X	MM	KK	LL	GG	HH	
006	18.00	25.00	60.00	2.54	5.65	N/A	13.50	15.88	11.50	3.50	10.86	4.76	2.81	2.85	N/A	8.47	8.06	0.63	11.75	
008	18.00	28.00	65.00	2.54	6.65	N/A	13.50	19.04	11.50	3.50	10.86	4.76	2.81	2.85	N/A	9.97	8.06	0.63	11.75	
012	18.00	31.50	67.00	2.54	7.83	N/A	13.50	21.75	11.50	3.50	10.86	4.76	2.81	2.85	N/A	11.72	8.06	0.63	11.75	
016	18.00	38.00	68.5	2.54	10.00	N/A	13.50	24.19	11.50	3.50	10.86	4.76	2.81	2.85	24.86	9.45	8.06	0.63	11.75	
020	18.00	43.00	69.00	2.54	11.65	N/A	13.50	24.19	11.50	3.50	10.86	4.76	2.81	2.85	24.86	10.08	8.06	0.63	11.75	
Size	External Filter																			
	A	B	C	G	H	K	L	Q	R	S	T	U	V	W	X	MM	KK	LL	GG	HH
006	23.07	25.00	60.00	2.54	5.65	18.00	13.50	14.78	12.09	3.50	23.63	10.86	4.76	2.81	2.85	N/A	8.47	8.06	0.63	11.75
008	23.07	28.00	65.00	2.54	6.65	18.00	13.50	17.85	12.09	3.50	26.63	10.86	4.76	2.81	2.85	N/A	9.97	8.06	0.63	11.75
012	23.07	31.50	67.00	2.54	7.83	18.00	13.50	20.63	12.09	3.50	30.18	10.86	4.76	2.81	2.85	N/A	11.72	8.06	0.63	11.75
016	23.07	38.00	68.5	2.54	10.00	18.00	13.50	23.00	12.09	3.50	36.63	10.86	4.76	2.81	2.85	24.86	9.45	8.06	0.63	11.75
020	23.07	43.00	69.00	2.54	11.65	18.00	13.50	23.00	12.09	3.50	41.63	10.86	4.76	2.81	2.85	24.86	10.08	8.06	0.63	11.75

Figure 47: Vertical Unit Dimensions (Sizes 030-050)



**Table 50: General Vertical Unit Dimensions for Figure 47 on page 62**

Units with Forward-Curved Fans													
	A	B	C	D	E	U	X	KK	LL	GG	HH	DCH	DCold Water
<b>SIZE 30</b>	35.36	49.5	61.5	44	42.5	5.54	30.49	12.3	15.32	5.29	13.66	24.5	38
<b>SIZE 40</b>	35.36	53.5	65.5	48	46.5	6	34.49	15.09	17.82	5.25	15.72	31.88	45.44
<b>SIZE 50</b>	35.36	53.5	73.5	48	46.5	6	42.49	15.09	17.82	5.25	15.72	39.88	45.44
Units with Plenum Fans													
	A	B	C	D	E	U	X	KK	LL	GG	HH	DCH	DCold Water
<b>SIZE 30</b>	35.36	49.5	61.5	44	42.5	5.54	30.49	8.67	27.20	3.96	16.20	24.5	38
<b>SIZE 40</b>	35.36	53.5	65.5	48	46.5	6	34.49	3.67	41.20	3.96	14.20	31.88	45.44
<b>SIZE 50</b>	35.36	53.5	73.5	48	46.5	6	42.49	4.17	40.20	3.96	18.20	39.88	45.44

**Table 52: Vertical Coil Dimensions for Figure 47 on page 62**

8 Row Coil RH (Cooling)													
	K	F	H	G	J	M	N	O	P	Q	R	S	T
<b>SIZE 30</b>	5.3	9.22	22.72	-	-	7.74	27.6	25.99	21.65	-	-	1.625	-
<b>SIZE 40</b>	5.3	9.22	26.72	-	-	5.42	27.59	25.98	21.65	-	-	1.875	-
<b>SIZE 50</b>	5.31	9.22	34.72	-	-	5.42	27.59	25.98	21.65	-	-	2.125	-
6 Row Coil RH (Cooling)													
	K	F	H	G	J	M	N	O	P	Q	R	S	T
<b>SIZE 30</b>	5.3	9.22	22.72	-	-	7.74	27.6	27.12	24.57	-	-	1.625	-
<b>SIZE 40</b>	5.3	9.22	26.72	-	-	5.42	27.59	27.17	24.57	-	-	1.625	-
<b>SIZE 50</b>	5.31	9.22	34.72	-	-	5.42	27.59	27.17	24.57	-	-	2.125	-
4 Row Coil RH (Cooling)													
	K	F	H	G	J	M	N	O	P	Q	R	S	T
<b>SIZE 30</b>	5.3	9.22	22.72	-	-	7.74	27.6	27.12	24.57	-	-	1.375	-
<b>SIZE 40</b>	5.3	9.22	26.72	-	-	5.42	27.59	27.17	24.57	-	-	1.625	-
<b>SIZE 50</b>	5.31	9.22	34.72	-	-	5.42	27.59	27.17	24.57	-	-	2.125	-
2 Row Coil RH (Cooling)													
	K	F	H	G	J	M	N	O	P	Q	R	S	T
<b>SIZE 30</b>	5.3	9.22	22.72	-	-	7.74	27.59	27.12	24.63	-	-	1.125	-
<b>SIZE 40</b>	5.3	9.22	26.72	-	-	5.42	27.59	27.17	24.57	-	-	1.375	-
<b>SIZE 50</b>	5.3	9.22	34.72	-	-	5.42	27.59	27.17	24.57	-	-	2.125	-
6 + 1 Rows Coil RH (Re-heat)													
	K	F	H	G	J	M	N	O	P	Q	R	S	T
<b>SIZE 30</b>	5.3	9.22	22.72	9.22	22.72	7.74	27.6	27.12	24.57	21.89	19.68	1.625	0.625
<b>SIZE 40</b>	5.3	9.22	26.72	9.22	26.72	5.42	27.59	27.17	24.57	21.89	19.68	1.625	0.875
<b>SIZE 50</b>	5.31	9.22	34.72	9.22	34.72	5.42	27.59	27.17	24.57	21.89	19.69	2.125	1.375
4 + 1 Rows Coil RH (Re-heat)													
	K	F	H	G	J	M	N	O	P	Q	R	S	T
<b>SIZE 30</b>	5.3	9.22	22.72	9.22	22.72	7.74	27.6	27.12	24.57	21.89	19.68	1.375	0.625
<b>SIZE 40</b>	5.3	9.22	26.72	9.22	26.72	5.42	27.59	27.17	24.57	21.89	19.68	1.625	0.875
<b>SIZE 50</b>	5.31	9.22	34.72	9.22	34.72	5.42	27.59	27.17	24.57	21.89	19.69	2.125	1.375
2 + 1 Rows Coil RH (Re-heat)													
	K	F	H	G	J	M	N	O	P	Q	R	S	T
<b>SIZE 30</b>	5.3	9.22	22.72	9.22	22.72	7.74	27.6	27.1	24.63	21.89	19.68	1.125	0.625
<b>SIZE 40</b>	5.3	9.22	26.72	9.22	26.72	5.42	27.59	27.17	24.57	21.89	19.68	1.375	0.875
<b>SIZE 50</b>	5.3	9.22	34.72	9.22	34.72	5.42	27.59	27.17	24.57	21.89	19.69	2.125	1.375
6 + 2 Rows Coil RH (Re-heat)													
	K	F	H	G	J	M	N	O	P	Q	R	S	T
<b>SIZE 30</b>	5.3	9.22	22.72	9.22	22.72	7.74	27.6	27.12	24.57	22.02	19.55	1.625	1.125
<b>SIZE 40</b>	5.3	9.22	26.72	9.22	26.72	5.42	27.59	27.17	24.57	22.09	19.49	1.625	1.375
<b>SIZE 50</b>	5.31	9.22	34.72	9.22	34.72	5.42	27.59	27.17	24.57	22.09	19.5	2.125	1.375
4 + 2 Rows Coil RH (Re-heat)													
	K	F	H	G	J	M	N	O	P	Q	R	S	T
<b>SIZE 30</b>	5.3	9.22	22.72	9.22	22.72	7.74	27.6	27.12	24.57	22.02	19.55	1.375	1.125
<b>SIZE 40</b>	5.3	9.22	26.72	9.22	26.72	5.42	27.59	27.17	24.57	22.09	19.49	1.625	1.375
<b>SIZE 50</b>	5.31	9.22	34.72	9.22	34.72	5.42	27.59	27.17	24.57	22.09	19.5	2.125	1.375



**Table 53: Vertical Coil Dimensions for Figure 47 on page 62 (continued)**

<b>2 + 2 Rows Coil RH (Re-heat)</b>													
	K	F	H	G	J	M	N	O	P	Q	R	S	T
<b>SIZE 30</b>	5.3	9.22	22.72	9.22	22.72	7.74	27.6	27.1	24.63	22.02	19.55	1.125	1.125
<b>SIZE 40</b>	5.3	9.22	26.72	9.22	26.72	5.42	27.59	27.17	24.57	22.09	19.49	1.375	1.375
<b>SIZE 50</b>	5.3	9.22	34.72	9.22	34.72	5.42	27.59	27.17	24.57	22.09	19.5	2.125	1.125
<b>1 + 6 Rows Coil RH (Pre-heat)</b>													
	K	F	H	G	J	M	N	O	P	Q	R	S	T
<b>SIZE 30</b>	5.3	9.22	22.72	9.22	22.72	7.74	27.6	27.95	25.75	23.07	20.47	1.625	0.625
<b>SIZE 40</b>	5.3	9.22	26.72	9.22	26.72	5.42	27.59	27.95	25.75	23.07	20.47	1.625	0.875
<b>SIZE 50</b>	5.3	9.22	34.72	9.22	34.72	5.42	27.95	27.59	25.75	23.07	20.47	2.125	1.375
<b>1 + 4 Rows Coil RH (Pre-heat)</b>													
	K	F	H	G	J	M	N	O	P	Q	R	S	T
<b>SIZE 30</b>	5.3	9.22	22.72	9.22	22.72	7.74	27.6	27.95	25.75	23.07	20.47	1.375	0.625
<b>SIZE 40</b>	5.3	9.22	26.72	9.22	26.72	5.42	27.59	27.95	25.75	23.07	20.47	1.625	0.875
<b>SIZE 50</b>	5.3	9.22	34.72	9.22	34.72	5.42	28.15	27.59	25.56	23.07	20.47	2.125	1.375
<b>1 + 2 Rows Coil RH (Pre-heat)</b>													
	K	F	H	G	J	M	N	O	P	Q	R	S	T
<b>SIZE 30</b>	5.3	9.22	22.72	9.22	22.72	7.74	27.6	27.95	25.75	23	20.53	1.125	0.625
<b>SIZE 40</b>	5.3	9.22	26.72	9.22	26.72	5.42	27.59	27.95	25.75	23.07	20.47	1.375	0.875
<b>SIZE 50</b>		9.22	34.72	9.22	34.72	5.42	28.15	27.59	25.56	23.07	20.47	2.125	1.375
<b>2 + 6 Rows Coil RH (Pre-heat)</b>													
	K	F	H	G	J	M	N	O	P	Q	R	S	T
<b>SIZE 30</b>	5.3	9.22	22.72	9.22	22.72	7.74	27.6	28.09	25.61	23.07	20.47	1.625	1.125
<b>SIZE 40</b>	5.3	9.22	26.72	9.22	26.72	5.42	27.59	28.15	25.55	23.07	20.47	1.625	1.375
<b>SIZE 50</b>	5.3	9.22	34.72	9.22	34.72	5.42	28.15	27.59	25.56	23.07	20.47	2.125	1.375
<b>2 + 4 Rows Coil RH (Pre-heat)</b>													
	K	F	H	G	J	M	N	O	P	Q	R	S	T
<b>SIZE 30</b>	5.3	9.22	22.72	9.22	22.72	7.74	27.6	28.09	25.61	23.07	20.47	1.375	1.125
<b>SIZE 40</b>	5.3	9.22	26.72	9.22	26.72	5.42	27.59	28.15	25.55	23.07	20.47	1.625	1.375
<b>SIZE 50</b>	5.3	9.22	34.72	9.22	34.72	5.42	28.15	27.59	25.56	23.07	20.47	2.125	1.375
<b>2 + 2 Rows Coil RH (Pre-heat)</b>													
	K	F	H	G	J	M	N	O	P	Q	R	S	T
<b>SIZE 30</b>	5.3	9.22	22.72	9.22	22.72	7.74	27.6	28.09	25.61	23	20.53	1.125	1.125
<b>SIZE 40</b>	5.3	9.22	26.72	9.22	26.72	5.42	27.59	28.15	25.55	23.07	20.47	1.375	1.375
<b>SIZE 50</b>	5.3	9.22	34.72	9.22	34.72	5.42	28.15	27.59	25.56	23.07	20.47	2.125	1.375
<b>1 + DX SINGLE 3 ROWS COIL RH (RE-HEAT)</b>													
	K	F	H	G	J	M	N	O	P	Q	R	S	T
<b>SIZE 30</b>	5.3	9.84	-	9.22	22.72	7.74	27.59	-	26.73	21.89	19.68	1.625	-
<b>SIZE 40</b>	5.3	9.84	-	9.22	26.72	5.42	27.59	-	26.73	21.89	19.68	1.625	-
<b>SIZE 50</b>	5.3	9.84	-	9.22	34.72	5.42	27.59	-	26.73	21.89	19.69	1.625	-
<b>2 + DX SINGLE 3 ROWS COIL RH (RE-HEAT)</b>													
	K	F	H	G	J	M	N	O	P	Q	R	S	T
<b>SIZE 30</b>	5.3	9.84	-	9.22	22.72	7.74	27.59	-	26.73	22.02	19.55	1.625	-
<b>SIZE 40</b>	5.3	9.84	-	9.22	26.72	5.42	27.59	-	26.73	22.09	19.49	1.625	-
<b>SIZE 50</b>	5.3	9.84	-	9.22	34.72	5.42	27.59	-	26.73	22.09	19.5	1.625	-
<b>1 + DX INTERLACE 3 ROWS COIL RH (RE-HEAT)</b>													
	K	F	H	G	J	M	N	O	P	Q	R	S	T
<b>SIZE 30</b>	5.3	9.84	14.47	9.22	22.72	7.74	27.59	27.56	25.42	21.89	19.68	0.875	-
<b>SIZE 40</b>	5.3	10.47	11.84	9.22	26.72	5.42	27.59	27.69	25.14	21.89	19.68	1.375	-
<b>SIZE 50</b>	5.3	10.47	11.84	9.22	34.72	5.42	27.59	27.72	25.17	21.89	19.69	1.375	-

**Table 54: Vertical Coil Dimensions for Figure 47 on page 62 (continued)**

<b>2 + DX INTERLACE 3 ROWS COIL RH (RE-HEAT)</b>													
	K	F	H	G	J	M	N	O	P	Q	R	S	T
<b>SIZE 30</b>	5.3	9.84	14.47	9.22	22.72	7.74	27.59	27.56	25.42	22.02	19.55	0.875	-
<b>SIZE 40</b>	5.3	10.47	11.84	9.22	26.72	5.42	27.59	27.69	25.14	22.09	19.49	1.375	-
<b>SIZE 50</b>	5.3	10.47	11.84	9.22	34.72	5.42	27.59	27.72	25.17	22.09	19.5	1.375	-
<b>1 + DX INTERLACE 6 ROWS COIL RH (RE-HEAT)</b>													
	K	F	H	G	J	M	N	O	P	Q	R	S	T
<b>SIZE 30</b>	5.3	10.47	14.22	9.22	22.72	7.74	27.59	27.12	24.97	21.89	19.68	1.125	-
<b>SIZE 40</b>	5.3	8.84	10.47	9.22	26.72	5.42	27.59	27.03	24.85	21.89	19.68	1.325	-
<b>SIZE 50</b>	5.3	10.47	10.47	9.22	34.72	5.42	27.59	26.73	24.61	21.89	19.69	1.625	-
<b>2 + DX INTERLACE 6 ROWS COIL RH (RE-HEAT)</b>													
	K	F	H	G	J	M	N	O	P	Q	R	S	T
<b>SIZE 30</b>	5.3	10.47	14.22	9.22	22.72	7.74	27.59	27.12	24.97	22.02	19.55	1.125	-
<b>SIZE 40</b>	5.3	8.84	10.47	9.22	26.72	5.42	27.59	27.03	24.85	22.09	19.49	1.325	-
<b>SIZE 50</b>	5.3	10.47	10.47	9.22	34.72	5.42	27.59	26.73	24.61	22.09	19.5	1.625	-
<b>1 + DX SINGLE 3 ROWS COIL RH (PRE-HEAT)</b>													
	K	F	H	G	J	M	N	O	P	Q	R	S	T
<b>SIZE 30</b>	5.3	9.22	22.72	-	9.84	7.74	27.59	27.95	25.75	22.64	-	1.125	-
<b>SIZE 40</b>	5.3	9.22	26.72	-	9.84	5.42	27.59	27.95	25.75	22.64	-	0.875	-
<b>SIZE 50</b>	5.3	9.22	34.72	-	9.84	5.42	27.59	27.59	25.75	22.64	-	1.375	-
<b>2 + DX SINGLE 3 ROWS COIL RH (PRE-HEAT)</b>													
	K	F	H	G	J	M	N	O	P	Q	R	S	T
<b>SIZE 30</b>	5.3	9.22	22.72	-	9.84	7.74	27.59	28.09	25.61	22.64	-	1.125	-
<b>SIZE 40</b>	5.3	9.22	26.72	-	9.84	5.42	27.59	28.15	25.55	22.64	-	0.875	-
<b>SIZE 50</b>	5.3	9.22	34.72	-	9.84	5.42	27.59	27.59	25.56	22.64	-	1.375	-
<b>1 + DX INTERLACE 3 ROWS COIL RH (PRE-HEAT)</b>													
	K	F	H	G	J	M	N	O	P	Q	R	S	T
<b>SIZE 30</b>	5.31	9.22	22.72	9.84	14.47	7.74	27.59	27.95	25.75	23.46	21.32	0.625	0.875
<b>SIZE 40</b>	5.31	9.22	26.72	11.84	10.47	5.42	27.59	27.95	25.75	23.62	21.07	0.875	1.375
<b>SIZE 50</b>	5.31	9.22	34.72	11.84	10.47	5.42	27.59	27.59	25.75	23.62	21.07	1.375	1.375
<b>2 + DX INTERLACE 3 ROWS COIL RH (PRE-HEAT)</b>													
	K	F	H	G	J	M	N	O	P	Q	R	S	T
<b>SIZE 30</b>	5.31	9.22	22.72	9.84	14.47	7.74	27.59	28.09	25.61	23.46	21.32	0.625	0.875
<b>SIZE 40</b>	5.31	9.22	26.72	11.84	10.47	5.42	27.59	28.15	25.55	23.62	21.07	0.875	1.375
<b>SIZE 50</b>	5.31	9.22	34.72	11.84	10.47	5.42	27.59	27.59	25.56	23.62	21.07	1.375	1.375
<b>1 + DX INTERLACE 6 ROWS COIL RH (PRE-HEAT)</b>													
	K	F	H	G	J	M	N	O	P	Q	R	S	T
<b>SIZE 30</b>	5.31	9.22	22.72	9.84	14.47	7.74	27.59	27.95	25.75	23.46	21.32	0.625	0.875
<b>SIZE 40</b>	5.31	9.22	26.72	11.84	10.47	5.42	27.59	27.95	25.75	23.62	21.07	0.875	1.375
<b>SIZE 50</b>	5.31	9.22	34.72	11.84	10.47	5.42	27.59	27.59	25.75	23.62	21.07	1.375	1.375
<b>2 + DX INTERLACE 6 ROWS COIL RH (PRE-HEAT)</b>													
	K	F	H	G	J	M	N	O	P	Q	R	S	T
<b>SIZE 30</b>	5.31	9.22	22.72	9.84	14.47	7.74	27.59	28.09	25.61	23.46	21.32	0.625	0.875
<b>SIZE 40</b>	5.31	9.22	26.72	11.84	10.47	5.42	27.59	28.15	25.55	23.62	21.07	0.875	1.375
<b>SIZE 50</b>	5.31	9.22	34.72	11.84	10.47	5.42	27.59	27.59	25.56	23.62	21.07	1.375	1.375
<b>Steam Coils</b>													
	K	F	H	G	J	M	N	O	P	Q	R		T
<b>SIZE 30</b>	5.31	-	-	9.67	21.71	-	-	-	-	25.72	28.03		1.125
<b>SIZE 40</b>	5.31	-	-	9.58	23.71	-	-	-	-	25.72	28.03		1.125
<b>SIZE 50</b>	5.31	-	-	9.84	27.71	-	-	-	-	25.82	27.97		1.375

Figure 48: Vertical Mixing Box - Top and End Damper. Sizes 030-050 - Side Filter Access.

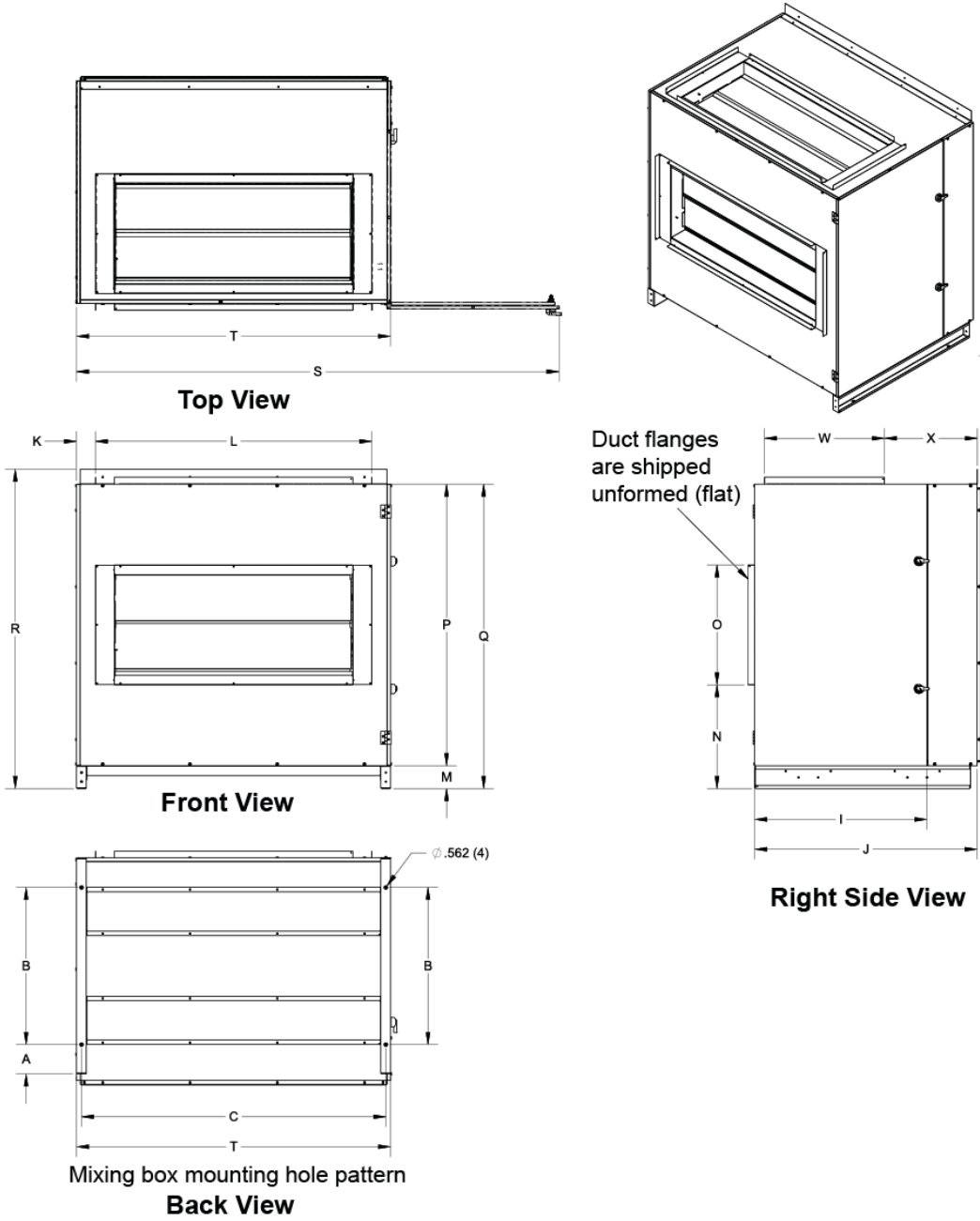


Table 55: Mixing Box Dimension Letter Reference

Mixing Box	Vertical Mixing Box																		
	A	B	C	D	I	J	K	L	M	N	O	P	Q	R	S	T	W	X	
910298850																			
SIZE 30	5.5	24	42.5	44	26.31	33	2.87	38.27	3.5	9.82	18.37	31	34.5	36.76	70.12	34	18.37	14.19	
SIZE 40	5.5	24	46.5	48	26.31	33	2.87	42.31	3.5	11.82	18.37	35	38.5	40.76	74.12	34	18.37	14.19	
SIZE 50	5.5	24	46.5	48	26.31	33	2.87	42.31	3.5	15.82	18.37	43	46.5	48.76	74.12	34	18.37	14.19	

Figure 49: Vertical Discharge Plenum (Sizes 030-050)

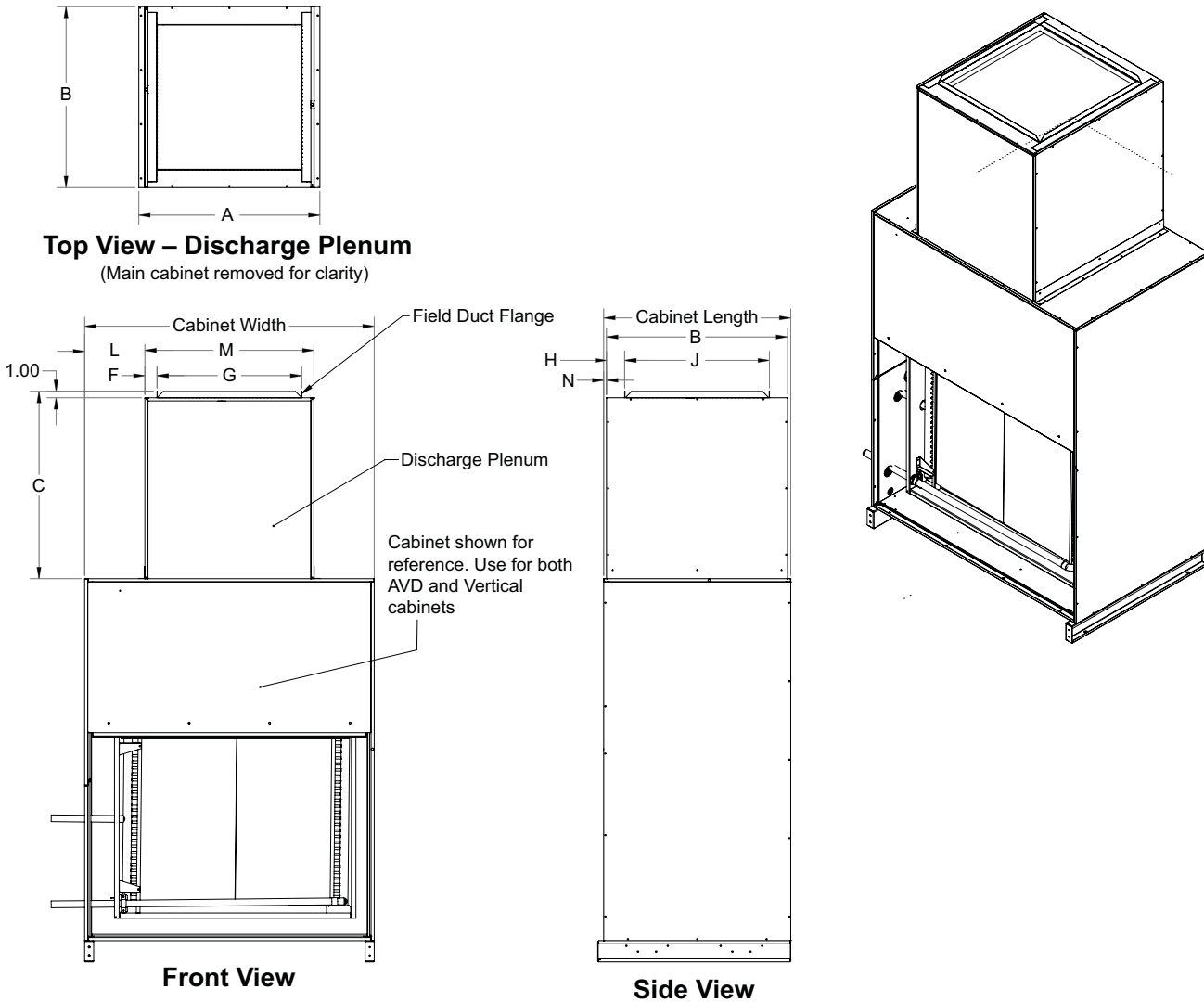


Table 56: Discharge Plenum Dimension Letter Reference

AVD										Cabinet Length	Cabinet Width	Cabinet Height
A	B	C	F	G	H	J	L	M	N			
14.00	17.50	25.00	2.00	8.06	2.75	12.00	6.50	12.00	0.25	18.00	25.00	58.00
18.00	17.50	25.00	2.00	12.00	2.75	12.00	6.00	16.00	0.25	18.00	28.00	60.00
20.00	17.50	25.00	2.00	14.00	2.75	12.00	6.75	18.00	0.25	18.00	31.50	62.00
31.00	17.50	25.00	5.47	20.00	1.75	14.00	6.75	29.00	0.25	18.00	38.00	63.50
33.00	17.50	25.00	2.47	20.00	1.75	14.00	6.00	31.00	0.25	18.00	43.00	64.00
Vertical										Cabinet Length	Cabinet Width	Cabinet Height
A	B	C	F	G	H	J	L	M	N			
26.00	30.00	31.00	2.00	20.00	5.00	20.00	10.00	24.00	0.50	31.00	44.00	56.00
30.00	30.00	31.00	2.00	24.00	3.00	24.00	10.00	28.00	0.50	31.00	48.00	60.00
30.00	30.00	31.00	2.00	24.00	3.00	24.00	10.00	28.00	0.50	31.00	48.00	68.00

# Size 060-100 Unit Dimensions

Figure 50: Coil Section Dimensions (Sizes 060-100)

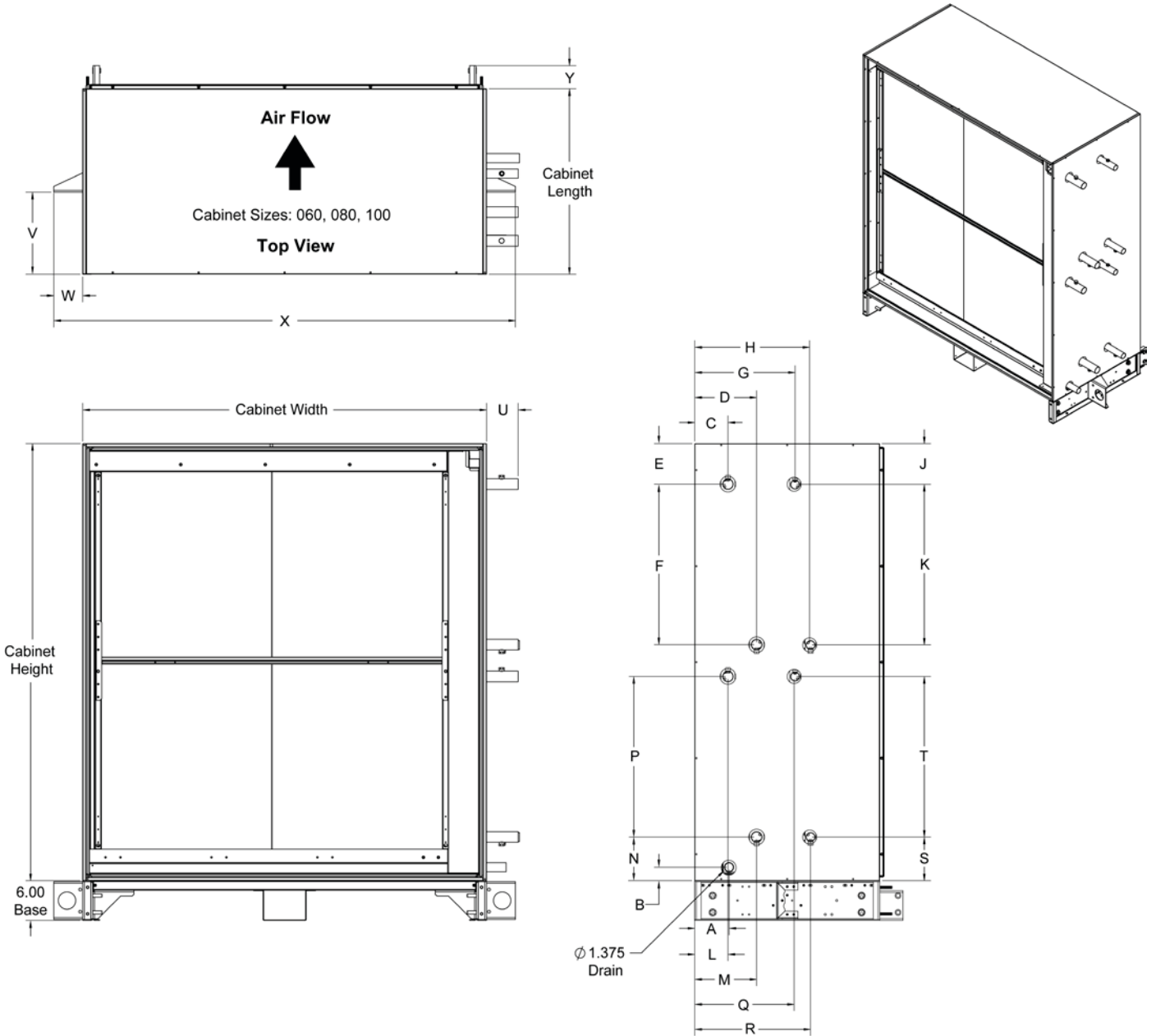


Table 57: General Unit Dimensions (Sizes 060-100)

	Length	Width	Height	U	V	W	X	Y
<b>SIZE 60</b>	28.00	54.00	54.00	4.19	12.39	4.38	62.75	3.50
<b>SIZE 80</b>	28.00	54.00	62.00	5.45	12.39	4.38	62.75	3.50
<b>SIZE 100</b>	28.00	61.00	66.00	4.79	12.39	4.38	69.75	3.50

**Table 58: Hydronic Coil Unit Dimensions (Sizes 060-100) for Figure 50 on page 68**

8-Row Cold Water + 2-Row Hot Water																		
	A	B	C	D	E	F	G	H	J	K	L	M	N	P	Q	R	S	T
SIZE 60	-	-	5.01	9.37	6.11	18.25	15.75	17.29	6.11	18.25	5.01	9.37	6.59	18.25	15.75	17.29	6.59	18.25
SIZE 80	-	-	5.03	9.36	6.11	22.25	15.75	17.29	6.11	22.25	5.03	9.36	6.59	22.25	15.75	17.29	6.59	22.25
SIZE 100	5.20	2.03	5.03	9.36	6.11	24.25	15.17	17.50	6.11	24.25	5.03	9.36	6.59	24.25	15.17	17.50	6.59	24.25
6-Row Cold Water + 2-Row Hot Water																		
	A	B	C	D	E	F	G	H	J	K	L	M	N	P	Q	R	S	T
SIZE 60	-	-	6.24	8.84	6.11	18.25	15.75	17.29	6.11	18.25	6.24	8.84	6.59	18.25	15.75	17.29	6.59	18.25
SIZE 80	-	-	6.24	8.83	6.11	22.25	15.75	17.29	6.11	22.25	6.24	8.83	6.59	22.25	15.75	17.29	6.59	22.25
SIZE 100	5.20	2.03	6.23	8.84	6.11	24.25	15.17	17.50	6.11	24.25	6.23	8.84	6.59	24.25	15.17	17.50	6.59	24.25
4-Row Cold Water + 2-Row Hot Water																		
	A	B	C	D	E	F	G	H	J	K	L	M	N	P	Q	R	S	T
SIZE 60	-	-	6.24	8.83	6.11	18.25	15.75	17.29	6.11	18.25	6.24	8.83	6.59	18.25	15.75	17.29	6.59	18.25
SIZE 80	-	-	5.36	7.96	6.11	22.25	15.75	17.29	6.11	22.25	5.36	7.96	6.59	22.25	15.75	17.29	6.59	22.25
SIZE 100	5.20	2.03	6.24	8.83	6.11	24.25	15.17	17.50	6.11	24.25	6.24	8.83	6.59	24.25	15.17	17.50	6.59	24.25
2-Row Cold Water + 2-Row Hot Water																		
	A	B	C	D	E	F	G	H	J	K	L	M	N	P	Q	R	S	T
SIZE 60	-	-	6.42	7.97	6.11	18.25	15.75	17.29	6.11	18.25	6.42	7.97	6.59	18.25	15.75	17.29	6.59	18.25
SIZE 80	-	-	6.42	7.97	6.11	22.25	15.75	17.29	6.11	22.25	6.42	7.97	6.59	22.25	15.75	17.29	6.59	22.25
SIZE 100	5.20	2.03	5.96	7.97	6.11	24.25	15.17	17.50	6.11	24.25	5.96	7.97	6.59	24.25	15.17	17.50	6.59	24.25
8-Row Cold Water + 1-Row Hot Water																		
	A	B	C	D	E	F	G	H	J	K	L	M	N	P	Q	R	S	T
SIZE 60	-	-	5.01	9.37	6.11	18.25	15.63	16.84	6.11	18.39	5.01	9.37	6.59	18.25	15.63	16.84	6.45	18.39
SIZE 80	-	-	5.03	9.36	6.11	22.25	15.49	16.84	7.61	19.75	5.03	9.36	6.59	22.25	15.49	16.84	7.59	19.75
SIZE 100	5.20	2.03	5.03	9.36	6.11	24.25	15.39	16.84	6.11	24.25	5.03	9.36	6.59	24.25	15.39	16.84	6.59	24.25
6-Row Cold Water + 1-Row Hot Water																		
	A	B	C	D	E	F	G	H	J	K	L	M	N	P	Q	R	S	T
SIZE 60	-	-	6.24	8.84	6.11	18.25	15.63	16.84	6.11	18.39	6.24	8.84	6.59	18.25	15.63	16.84	6.45	18.39
SIZE 80	-	-	6.24	8.83	6.11	22.25	15.48	16.83	7.61	19.75	6.24	8.83	6.59	22.25	15.48	16.83	7.59	19.75
SIZE 100	5.20	2.03	6.23	8.84	6.11	24.25	15.39	16.84	6.11	24.25	6.23	8.84	6.59	24.25	15.39	16.84	6.59	24.25
4-Row Cold Water + 1-Row Hot Water																		
	A	B	C	D	E	F	G	H	J	K	L	M	N	P	Q	R	S	T
SIZE 60	-	-	6.24	8.83	6.11	18.25	15.63	16.84	6.11	18.39	6.24	8.83	6.59	18.25	15.63	16.84	6.45	18.39
SIZE 80	-	-	5.36	7.96	6.11	22.25	15.48	16.83	7.61	19.75	5.36	7.96	6.59	22.25	15.48	16.83	7.59	19.75
SIZE 100	5.20	2.03	6.24	8.83	6.11	24.25	15.39	16.84	6.11	24.25	6.24	8.83	6.59	24.25	15.39	16.84	6.59	24.25
2-Row Cold Water + 1-Row Hot Water																		
	A	B	C	D	E	F	G	H	J	K	L	M	N	P	Q	R	S	T
SIZE 60	-	-	6.42	7.97	6.11	18.25	15.63	16.84	6.11	18.39	6.42	7.97	6.59	18.25	15.63	16.84	6.45	18.39
SIZE 80	-	-	6.42	7.97	6.11	22.25	15.48	16.83	7.61	19.75	6.42	7.97	6.59	22.25	15.48	16.83	7.59	19.75
SIZE 100	5.20	2.03	5.96	7.97	6.11	24.25	15.39	16.84	6.11	24.25	5.96	7.97	6.59	24.25	15.39	16.84	6.59	24.25
2-Row Hot Water + 8-Row Cold Water																		
	A	B	C	D	E	F	G	H	J	K	L	M	N	P	Q	R	S	T
SIZE 60	-	-	7.45	9.00	6.11	18.25	12.22	16.58	6.11	18.25	7.45	9.00	6.59	18.25	12.22	16.58	6.59	18.25
SIZE 80	-	-	7.50	9.04	6.11	22.25	12.28	16.61	6.11	22.25	7.50	9.04	6.59	22.25	12.28	16.61	6.59	22.25
SIZE 100	5.20	2.03	6.92	9.25	6.11	24.25	12.28	16.61	6.11	24.25	6.92	9.25	6.59	24.25	12.28	16.61	6.59	24.25
2-Row Hot Water + 6-Row Cold Water																		
	A	B	C	D	E	F	G	H	J	K	L	M	N	P	Q	R	S	T
SIZE 60	-	-	7.45	9.00	6.11	18.25	13.45	16.05	6.11	18.25	7.45	9.00	6.59	18.25	13.45	16.05	6.59	18.25
SIZE 80	-	-	7.50	9.04	6.11	22.25	13.49	16.08	6.11	22.25	7.50	9.04	6.59	22.25	13.49	16.08	6.59	22.25
SIZE 100	5.20	2.03	6.92	9.25	6.11	24.25	13.48	16.09	6.11	24.25	6.92	9.25	6.59	24.25	13.48	16.09	6.59	24.25
2-Row Hot Water + 4-Row Cold Water																		
	A	B	C	D	E	F	G	H	J	K	L	M	N	P	Q	R	S	T
SIZE 60	-	-	7.45	9.00	6.11	18.25	13.45	16.04	6.11	18.25	7.45	9.00	6.59	18.25	13.45	16.04	6.59	18.25
SIZE 80	-	-	7.50	9.04	6.11	22.25	12.61	15.21	6.11	22.25	7.50	9.04	6.59	22.25	12.61	15.21	6.59	22.25
SIZE 100	5.20	2.03	6.92	9.25	6.11	24.25	13.49	16.08	6.11	24.25	6.92	9.25	6.59	24.25	13.49	16.08	6.59	24.25
2-Row Hot Water + 2-Row Cold Water																		
	A	B	C	D	E	F	G	H	J	K	L	M	N	P	Q	R	S	T
SIZE 60	-	-	7.45	9.00	6.11	18.25	13.63	15.18	6.11	18.25	7.45	9.00	6.59	18.25	13.63	15.18	6.59	18.25
SIZE 80	-	-	7.50	9.04	6.11	22.25	13.67	15.22	6.11	22.25	7.50	9.04	6.59	22.25	13.67	15.22	6.59	22.25
SIZE 100	5.20	2.03	6.92	9.25	6.11	24.25	13.21	15.22	6.11	24.25	6.92	9.25	6.59	24.25	13.21	15.22	6.59	24.25

1-Row Hot Water + 8-Row Cold Water																		
	A	B	C	D	E	F	G	H	J	K	L	M	N	P	Q	R	S	T
SIZE 60	-	-	7.34	8.55	6.11	18.39	12.22	16.58	6.11	18.25	7.34	8.55	6.45	18.39	12.22	16.58	6.59	18.25
SIZE 80	-	-	7.23	8.58	7.61	19.75	12.28	16.61	6.11	22.25	7.23	8.58	7.59	19.75	12.28	16.61	6.59	22.25
SIZE 100	5.20	2.03	7.14	8.59	6.11	24.25	12.28	16.61	6.11	24.25	7.14	8.59	6.59	24.25	12.28	16.61	6.59	24.25
1-Row Hot Water + 6-Row Cold Water																		
	A	B	C	D	E	F	G	H	J	K	L	M	N	P	Q	R	S	T
SIZE 60	-	-	7.34	8.55	6.11	18.39	13.45	16.05	6.11	18.25	7.34	8.55	6.45	18.39	13.45	16.05	6.59	18.25
SIZE 80	-	-	7.23	8.58	7.61	19.75	13.49	16.08	6.11	22.25	7.23	8.58	7.59	19.75	13.49	16.08	6.59	22.25
SIZE 100	5.20	2.03	7.14	8.59	6.11	24.25	13.48	16.09	6.11	24.25	7.14	8.59	6.59	24.25	13.48	16.09	6.59	24.25
1-Row Hot Water + 4-Row Cold Water																		
	A	B	C	D	E	F	G	H	J	K	L	M	N	P	Q	R	S	T
SIZE 60	-	-	7.34	8.55	6.11	18.39	13.45	16.04	6.11	18.25	7.34	8.55	6.45	18.39	13.45	16.04	6.59	18.25
SIZE 80	-	-	7.23	8.58	7.61	19.75	12.61	15.21	6.11	22.25	7.23	8.58	7.59	19.75	12.61	15.21	6.59	22.25
SIZE 100	5.20	2.03	7.14	8.59	6.11	24.25	13.49	16.08	6.11	24.25	7.14	8.59	6.59	24.25	13.49	16.08	6.59	24.25
1-Row Hot Water + 2-Row Cold Water																		
	A	B	C	D	E	F	G	H	J	K	L	M	N	P	Q	R	S	T
SIZE 60	-	-	7.34	8.55	6.11	18.39	13.63	15.18	6.11	18.25	7.34	8.55	6.45	18.39	13.63	15.18	6.59	18.25
SIZE 80	-	-	7.23	8.58	7.61	19.75	13.67	15.22	6.11	22.25	7.23	8.58	7.61	19.75	13.67	15.22	6.59	22.25
SIZE 100	5.20	2.03	7.14	8.59	6.11	24.25	13.21	15.22	6.11	24.25	7.14	8.59	6.59	24.25	13.21	15.22	6.59	24.25
8-Row																		
	A	B	C	D	E	F	G	H	J	K	L	M	N	P	Q	R	S	T
SIZE 60	-	-	5.01	9.37	6.11	18.25	-	-	-	-	5.01	9.37	6.59	18.25	-	-	-	-
SIZE 80	-	-	5.03	9.36	6.11	22.25	-	-	-	-	5.03	9.36	6.59	22.25	-	-	-	-
SIZE 100	5.20	2.03	5.03	9.36	6.11	24.25	-	-	-	-	5.03	9.36	6.59	24.25	-	-	-	-
6-Row																		
	A	B	C	D	E	F	G	H	J	K	L	M	N	P	Q	R	S	T
SIZE 60	-	-	6.24	8.84	6.11	18.25	-	-	-	-	6.24	8.84	6.59	18.25	-	-	-	-
SIZE 80	-	-	6.24	8.83	6.11	22.25	-	-	-	-	6.24	8.83	6.59	22.25	-	-	-	-
SIZE 100	5.20	2.03	6.23	8.84	6.11	24.25	-	-	-	-	6.23	8.84	6.59	24.25	-	-	-	-
4-Row																		
	A	B	C	D	E	F	G	H	J	K	L	M	N	P	Q	R	S	T
SIZE 60	-	-	6.24	8.83	6.11	18.25	-	-	-	-	6.24	8.83	6.59	18.25	-	-	-	-
SIZE 80	-	-	5.36	7.96	6.11	22.25	-	-	-	-	5.36	7.96	6.59	22.25	-	-	-	-
SIZE 100	5.20	2.03	6.24	8.83	6.11	24.25	-	-	-	-	6.24	8.83	6.59	24.25	-	-	-	-
2-Row																		
	A	B	C	D	E	F	G	H	J	K	L	M	N	P	Q	R	S	T
SIZE 60	-	-	6.42	7.97	6.11	18.25	-	-	-	-	6.42	7.97	6.59	18.25	-	-	-	-
SIZE 80	-	-	6.42	7.97	6.11	22.25	-	-	-	-	6.42	7.97	6.59	22.25	-	-	-	-
SIZE 100	5.20	2.03	5.96	7.97	6.11	24.25	-	-	-	-	5.96	7.97	6.59	24.25	-	-	-	-



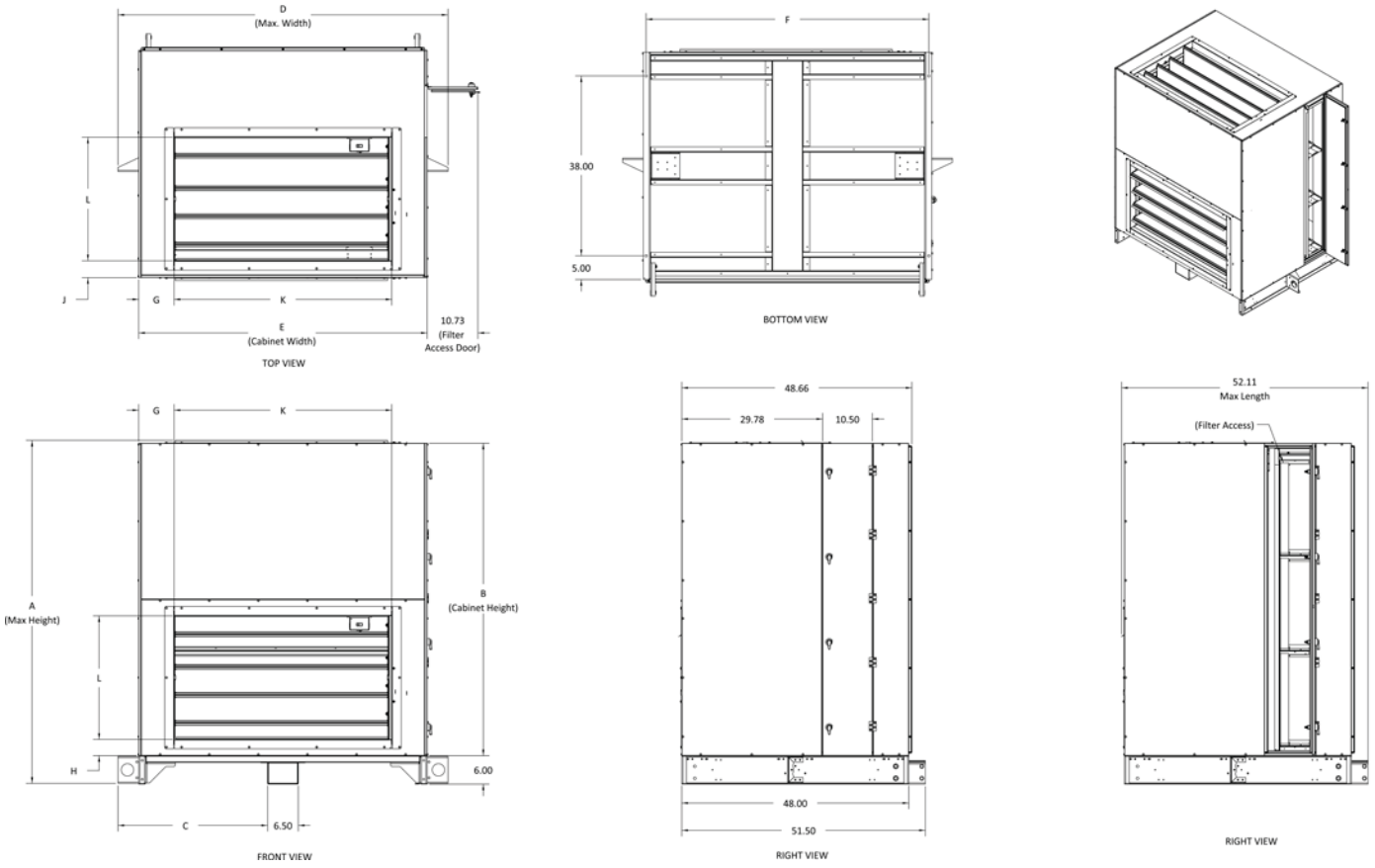
**Table 59: DX Unit Dimensions (Sizes 060-100) for Figure 50 on page 68**

DX SINGLE + 2-Row Hot Water																		
	A	B	C	D	E	F	G	H	J	K	L	M	N	P	Q	R	S	T
SIZE 60	-	-	6.67	-	24.63	-	15.75	17.29	6.11	18.25	6.67	-	6.33	-	15.75	17.29	6.59	18.25
SIZE 80	-	-	6.67	-	28.63	-	15.75	17.29	6.11	22.25	6.67	-	6.33	-	15.75	17.29	6.59	22.25
SIZE 100	5.20	2.03	6.67	-	30.61	-	15.17	17.50	6.11	24.25	6.67	-	6.33	-	15.17	17.50	6.59	24.25
DX SINGLE + 1-Row Hot Water																		
	A	B	C	D	E	F	G	H	J	K	L	M	N	P	Q	R	S	T
SIZE 60	-	-	6.67	-	24.63	-	15.63	16.84	6.11	18.39	6.67	-	6.33	-	15.63	16.84	6.45	18.39
SIZE 80	-	-	6.67	-	28.63	-	15.48	16.83	7.61	19.75	6.67	-	6.33	-	15.48	16.83	7.59	19.75
SIZE 100	5.20	2.03	6.67	-	30.61	-	15.39	16.84	6.11	24.25	6.67	-	6.33	-	15.39	16.84	6.59	24.25
DX INTERLACED + 2-Row Hot Water																		
	A	B	C	D	E	F	G	H	J	K	L	M	N	P	Q	R	S	T
SIZE 60	-	-	6.67	7.98	19.63	4.00	15.75	17.29	6.11	18.25	6.67	7.98	7.33	4.00	15.75	17.29	6.59	18.25
SIZE 80	-	-	6.66	8.10	23.63	4.00	15.75	17.29	6.11	22.25	6.66	8.10	7.33	4.00	15.75	17.29	6.59	22.25
SIZE 100	5.20	2.03	5.11	8.23	27.61	2.00	15.17	17.50	6.11	24.25	5.11	8.23	9.33	2.00	15.17	17.50	7.33	24.25
DX INTERLACED + 1-Row Hot Water																		
	A	B	C	D	E	F	G	H	J	K	L	M	N	P	Q	R	S	T
SIZE 60	-	-	6.67	7.98	19.63	4.00	15.63	16.84	6.11	18.39	6.67	7.98	7.33	4.00	15.63	16.84	6.45	18.39
SIZE 80	-	-	6.66	8.10	23.63	4.00	15.48	16.83	7.61	19.75	6.66	8.10	7.33	4.00	15.48	16.83	7.59	19.75
SIZE 100	5.20	2.03	5.11	8.23	27.61	2.00	15.39	16.84	6.11	24.25	5.11	8.23	9.33	2.00	15.39	16.84	7.33	24.25
2-Row Hot Water + DX SINGLE																		
	A	B	C	D	E	F	G	H	J	K	L	M	N	P	Q	R	S	T
SIZE 60	-	-	7.45	9.00	6.11	18.25	-	13.88	-	24.63	7.45	9.00	6.59	18.25	-	13.88	6.33	-
SIZE 80	-	-	7.50	9.04	6.11	22.25	13.92	-	28.63	-	7.50	9.04	6.59	22.25	13.92	-	6.33	-
SIZE 100	5.20	2.03	6.92	9.25	6.11	24.25	13.92	-	30.63	-	6.92	9.25	6.59	24.25	13.92	-	6.33	-
1-Row Hot Water + DX SINGLE																		
	A	B	C	D	E	F	G	H	J	K	L	M	N	P	Q	R	S	T
SIZE 60	-	-	7.34	8.55	6.11	18.39	-	13.88	-	24.63	7.34	8.55	6.45	18.39	-	13.88	6.33	-
SIZE 80	-	-	7.23	8.58	7.61	19.75	13.92	-	28.63	-	7.23	8.58	7.59	19.75	13.92	-	6.33	-
SIZE 100	5.20	2.03	7.14	8.59	6.11	24.25	13.92	-	30.63	-	7.14	8.59	6.59	24.25	13.92	-	6.33	-
2-Row Hot Water + DX INTERLACED																		
	A	B	C	D	E	F	G	H	J	K	L	M	N	P	Q	R	S	T
SIZE 60	-	-	7.45	9.00	6.11	18.25	13.88	15.19	19.63	4.00	7.45	9.00	6.59	18.25	13.88	15.19	7.33	4.00
SIZE 80	-	-	7.50	9.04	6.11	22.25	13.91	15.35	23.63	4.00	7.50	9.04	6.59	22.25	13.91	15.35	7.33	4.00
SIZE 100	5.20	2.03	6.92	9.25	6.11	24.25	12.35	15.48	27.61	2.00	6.92	9.25	9.33	24.25	12.35	15.48	7.33	2.00
1-Row Hot Water + DX INTERLACED																		
	A	B	C	D	E	F	G	H	J	K	L	M	N	P	Q	R	S	T
SIZE 60	-	-	7.34	8.55	6.11	18.39	13.88	15.19	19.63	4.00	7.34	8.55	6.45	18.39	13.88	15.19	7.33	4.00
SIZE 80	-	-	7.23	8.58	7.61	19.75	13.91	15.35	23.63	4.00	7.23	8.58	7.59	19.75	13.91	15.35	7.33	4.00
SIZE 100	5.20	2.03	7.14	8.59	6.11	24.25	12.35	15.48	27.61	2.00	7.14	8.59	9.33	24.25	12.35	15.48	7.33	2.00
DX SINGLE																		
	A	B	C	D	E	F	G	H	J	K	L	M	N	P	Q	R	S	T
SIZE 60	-	-	6.67	-	24.63	-	-	-	-	-	6.67	-	6.33	-	-	-	-	-
SIZE 80	-	-	6.67	-	28.63	-	-	-	-	-	6.69	-	6.33	-	-	-	-	-
SIZE 100	5.20	2.03	6.67	-	30.61	-	-	-	-	-	6.67	-	6.33	-	-	-	-	-
DX INTERLACED																		
	A	B	C	D	E	F	G	H	J	K	L	M	N	P	Q	R	S	T
SIZE 60	-	-	6.67	7.98	19.63	4.00	-	-	-	-	6.67	7.98	7.33	4.00	-	-	-	-
SIZE 80	-	-	6.66	8.10	23.63	4.00	-	-	-	-	6.66	8.10	7.33	4.00	-	-	-	-
SIZE 100	5.20	2.03	5.11	8.23	27.61	2.00	-	-	-	-	5.11	8.23	9.33	2.00	-	-	-	-

**Table 60: Steam Unit Dimensions (Sizes 060-100) for Figure 50 on page 68**

Steam + 8-Row Cold Water																		
	A	B	C	D	E	F	G	H	J	K	L	M	N	P	Q	R	S	T
<b>SIZE 60</b>	-	-	7.68	5.35	14.27	11.24	12.22	16.58	6.11	18.25	7.68	5.35	5.44	11.24	12.22	16.58	6.59	18.25
<b>SIZE 80</b>	-	-	7.80	5.49	16.07	13.38	12.28	16.61	6.11	22.25	7.80	5.49	5.50	13.38	12.28	16.61	6.59	22.25
<b>SIZE 100</b>	5.20	2.03	7.80	5.48	17.06	14.65	12.28	16.61	6.11	24.25	7.80	5.48	5.25	14.65	12.28	16.61	6.59	24.25
Steam + 6-Row Cold Water																		
	A	B	C	D	E	F	G	H	J	K	L	M	N	P	Q	R	S	T
<b>SIZE 60</b>	-	-	7.68	5.35	14.27	11.24	13.45	16.05	6.11	18.25	7.68	5.35	5.44	11.24	13.45	16.05	6.59	18.25
<b>SIZE 80</b>	-	-	7.80	5.49	16.07	13.38	13.49	16.08	6.11	22.25	7.80	5.49	5.50	13.38	13.49	16.08	6.59	22.25
<b>SIZE 100</b>	5.20	2.03	7.80	5.48	17.06	14.65	13.48	16.09	6.11	24.25	7.80	5.48	5.25	14.65	13.48	16.09	6.59	24.25
Steam + 4-Row Cold Water																		
	A	B	C	D	E	F	G	H	J	K	L	M	N	P	Q	R	S	T
<b>SIZE 60</b>	-	-	7.68	5.35	14.27	11.24	13.45	16.04	6.11	18.25	7.68	5.35	5.44	11.24	13.45	16.04	6.59	18.25
<b>SIZE 80</b>	-	-	7.80	5.49	16.07	13.38	12.61	15.21	6.11	22.25	7.80	5.49	5.50	13.38	12.61	15.21	6.59	22.25
<b>SIZE 100</b>	5.20	2.03	7.80	5.48	17.06	14.65	13.49	16.08	6.11	24.25	7.80	5.48	5.25	14.65	13.49	16.08	6.59	24.25
Steam + 2-Row Cold Water																		
	A	B	C	D	E	F	G	H	J	K	L	M	N	P	Q	R	S	T
<b>SIZE 60</b>	-	-	7.68	5.35	14.27	11.24	13.63	15.18	6.11	18.25	7.68	5.35	5.44	11.24	13.63	15.18	6.59	18.25
<b>SIZE 80</b>	-	-	7.80	5.49	16.07	13.38	13.67	15.22	6.11	22.25	7.80	5.49	5.50	13.38	13.67	15.22	6.59	22.25
<b>SIZE 100</b>	5.20	2.03	7.80	5.48	17.06	14.65	13.21	15.22	6.11	24.25	7.80	5.48	5.25	14.65	13.21	15.22	6.59	24.25
Steam + DX Single																		
	A	B	C	D	E	F	G	H	J	K	L	M	N	P	Q	R	S	T
<b>SIZE 60</b>	-	-	7.68	5.35	14.27	11.24	13.92	-	24.63	-	7.68	5.35	5.44	11.24	13.92	-	6.33	-
<b>SIZE 80</b>	-	-	7.80	5.49	16.07	13.38	13.92	-	28.63	-	7.80	5.49	5.50	13.38	13.92	-	6.33	-
<b>SIZE 100</b>	5.20	2.03	7.80	5.48	17.06	14.65	13.92	-	30.63	-	7.80	5.48	5.25	14.65	13.92	-	6.33	-
Steam + DX Interlaced																		
	A	B	C	D	E	F	G	H	J	K	L	M	N	P	Q	R	S	T
<b>SIZE 60</b>	-	-	7.68	5.35	14.27	11.24	13.92	15.23	19.63	4.00	7.68	5.35	5.44	11.24	13.92	15.23	7.33	4.00
<b>SIZE 80</b>	-	-	7.80	5.49	16.07	13.38	13.91	15.35	23.63	4.00	7.80	5.49	5.50	13.38	13.91	15.35	7.33	4.00
<b>SIZE 100</b>	5.20	2.03	7.80	5.48	17.06	14.65	12.35	15.48	27.61	2.00	7.80	5.48	5.25	14.65	12.35	15.48	7.33	2.00

**Figure 51: Mixing Box Dimensions (Sizes 060-100)**



**Table 61: Mixing Box Dimension Letter Reference**

Dimension	060	080	100
A	60.00	68.00	72.00
B	54.00	62.00	66.00
C	28.13	28.13	31.63
D	62.75	62.75	69.75
E	54.00	54.00	61.00
F	52.76	52.76	59.76
G	10.19	4.94	7.49
H	2.45	2.45	3.43
J	3.16	3.16	3.53
K	33.63	44.13	46.03
L	22.07	22.07	26.11

Figure 52: Discharge Plenum Without Filter (Sizes 060-100)

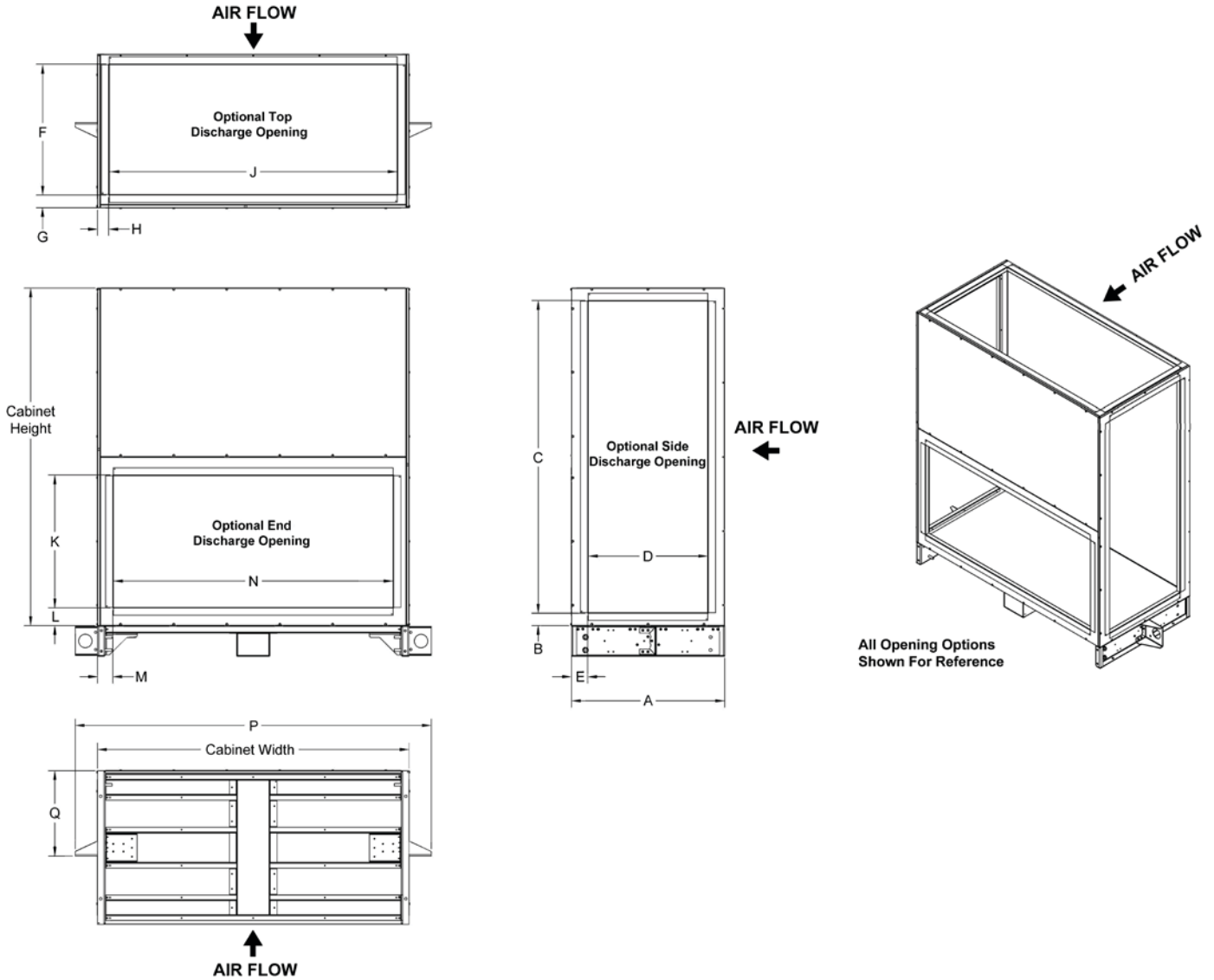
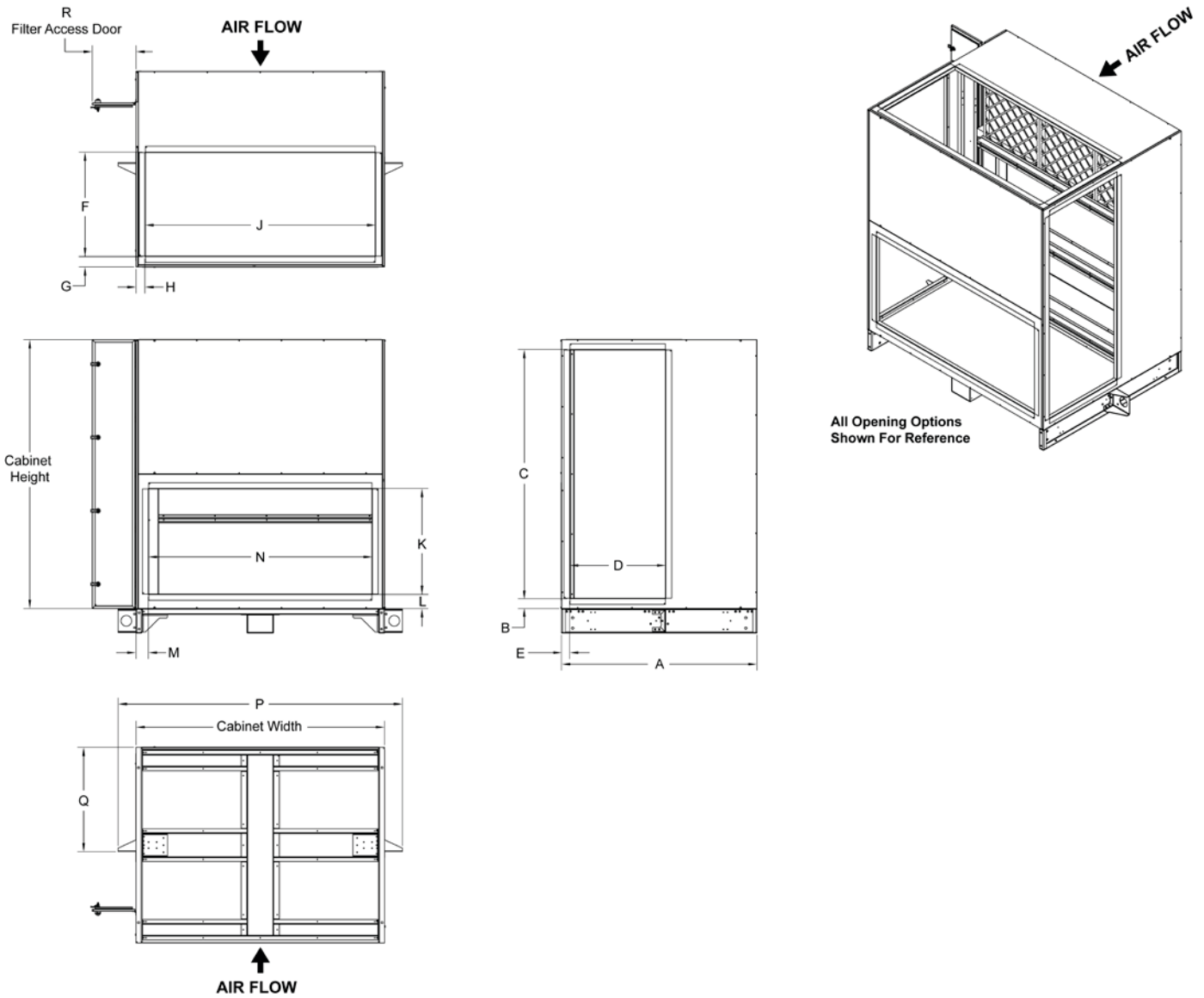


Table 62: Discharge Plenum Without Filter Dimension Letter Reference

Dimension	060	080	100
A	30.00	30.00	30.00
B	3.00	7.00	2.50
C	48.00	48.00	61.00
D	18.00	24.00	23.50
E	7.16	2.99	3.23
F	20.00	24.00	26.00
G	2.60	3.25	2.50
H	7.50	3.00	2.25
J	43.00	48.00	55.00
K	20.00	24.00	26.00
L	3.49	3.49	3.46
M	5.50	3.00	3.00
N	43.00	48.00	55.00
P	62.75	62.75	69.75
Q	16.61	16.61	16.61

Dimension	060	080	100
Length	30	30	30
Width	54	54	61
Height	54	62	66

**Figure 53: Discharge Plenum With Filter (Sizes 060-100)**



**Table 63: Discharge Plenum With Filter Dimension Letter Reference**

Dimension	060	080	100
A	48.00	48.00	48.00
B	3.00	7.00	2.50
C	48.00	48.00	61.00
D	18.00	24.00	23.50
E	4.81	3.06	2.06
F	20.00	24.00	26.00
G	2.60	2.60	2.06
H	7.50	3.00	2.25
J	43.00	48.00	55.00
K	20.00	24.00	26.00
L	3.49	3.49	3.46
M	5.50	3.00	3.00
N	43.00	48.00	55.00
P	62.75	62.75	69.75
Q	25.61	25.61	25.61
R	10.73	10.73	10.73

Dimension	060	080	100
Length	48	48	48
Width	54	54	61
Height	54	62	66

Figure 54: Exhaust Air / Outdoor Air Dimensions (Sizes 060-100)

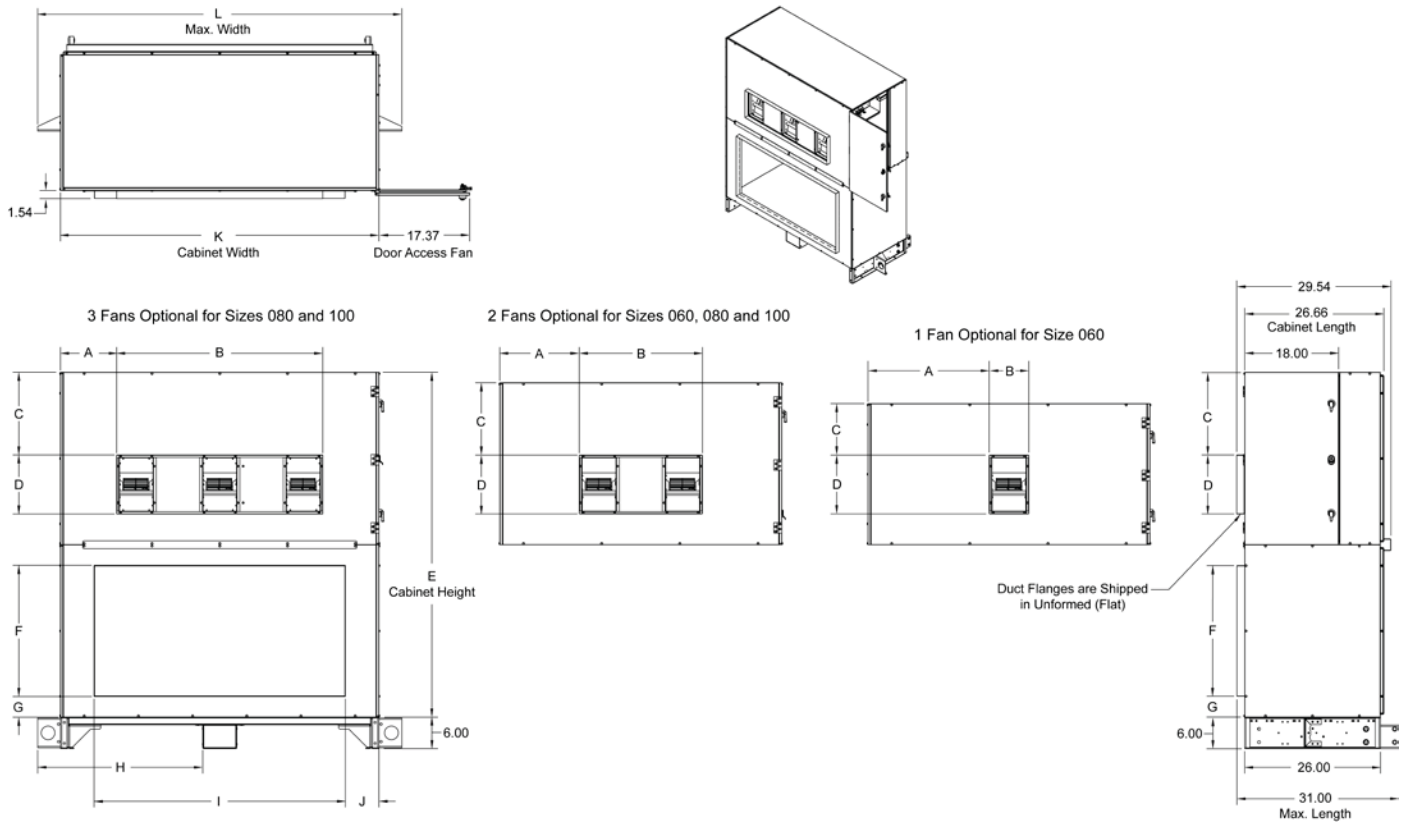


Table 64: Exhaust Air / Outdoor Air Section Dimension Letter Reference

Dimension	060		080		100	
	1 Fan	2 Fans	2 Fans	3 Fans	2 Fans	3 Fans
A	23.20	15.20	15.20	7.20	18.75	10.75
B	7.60	23.60	23.60	39.61	23.50	39.61
C	9.84	9.84	13.84	13.81	15.84	15.81
D	11.26	11.26	11.26	11.26	11.26	11.26
E	54.00		62.00		66.00	
F	20.00		24.00		25.00	
G	3.50		3.50		4.00	
H	23.75		23.75		31.63	
I	36.00		40.00		48.00	
J	9.00		7.00		6.50	
K	54.00		54.00		61.00	
L	62.75		62.75		69.75	

Figure 55: Economizer Dimensions (Sizes 060-100)

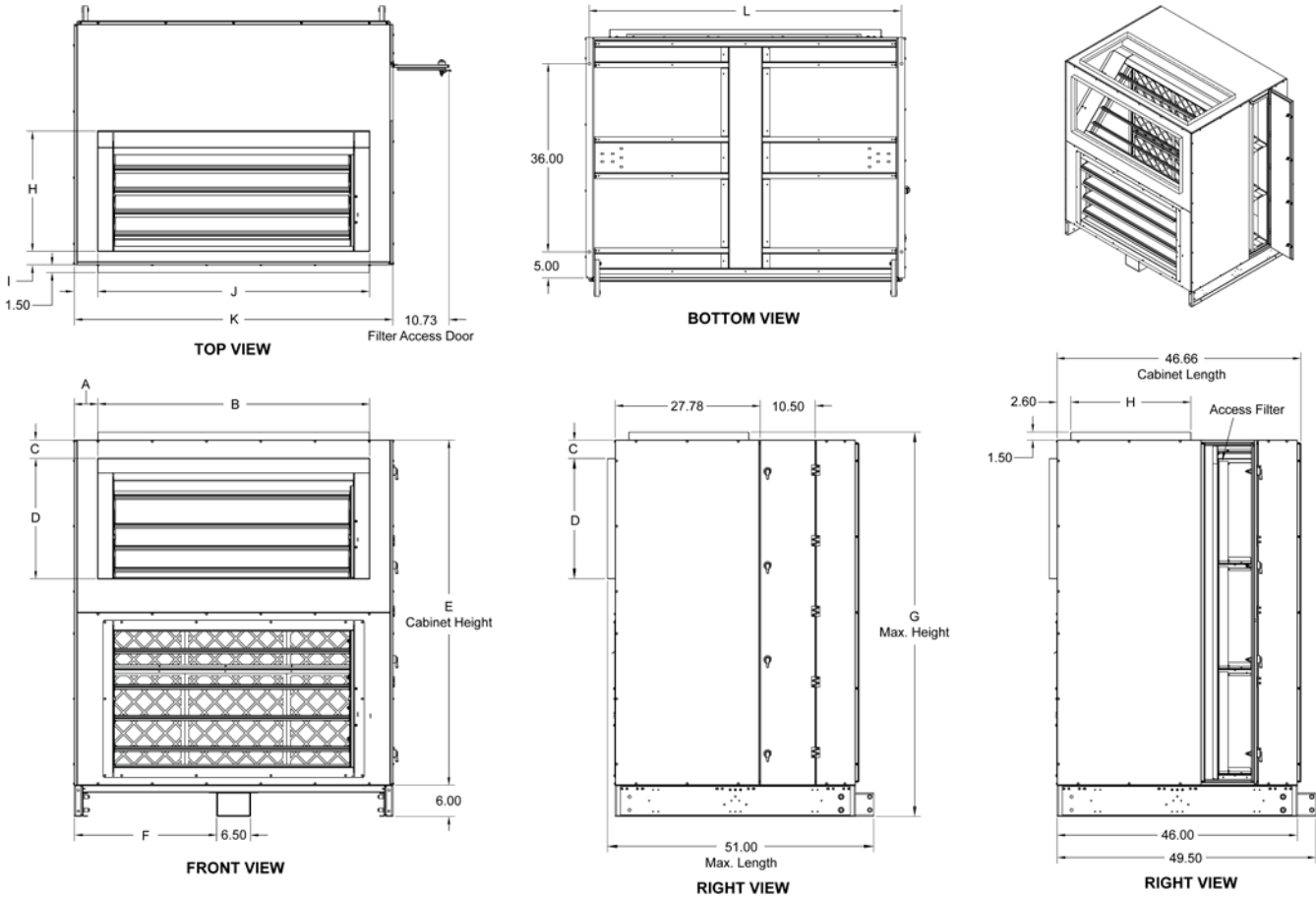


Table 65: Economizer Section Dimension Letter Reference

Dimension	060	080	100
A	7.00	5.00	4.50
B	40.00	44.00	52.00
C	54.00	62.00	66.00
D	23.75	23.75	27.25
E	61.50	69.50	73.50
F	18.00	22.00	23.19
G	54.00	54.00	61.00
H	52.76	52.76	59.76
I	6.50	4.00	4.50
J	40.00	46.00	52.00
K	54.00	54.00	61.00
L	52.76	52.76	59.76



Figure 56: Return Filter Dimensions (Sizes 060-100)

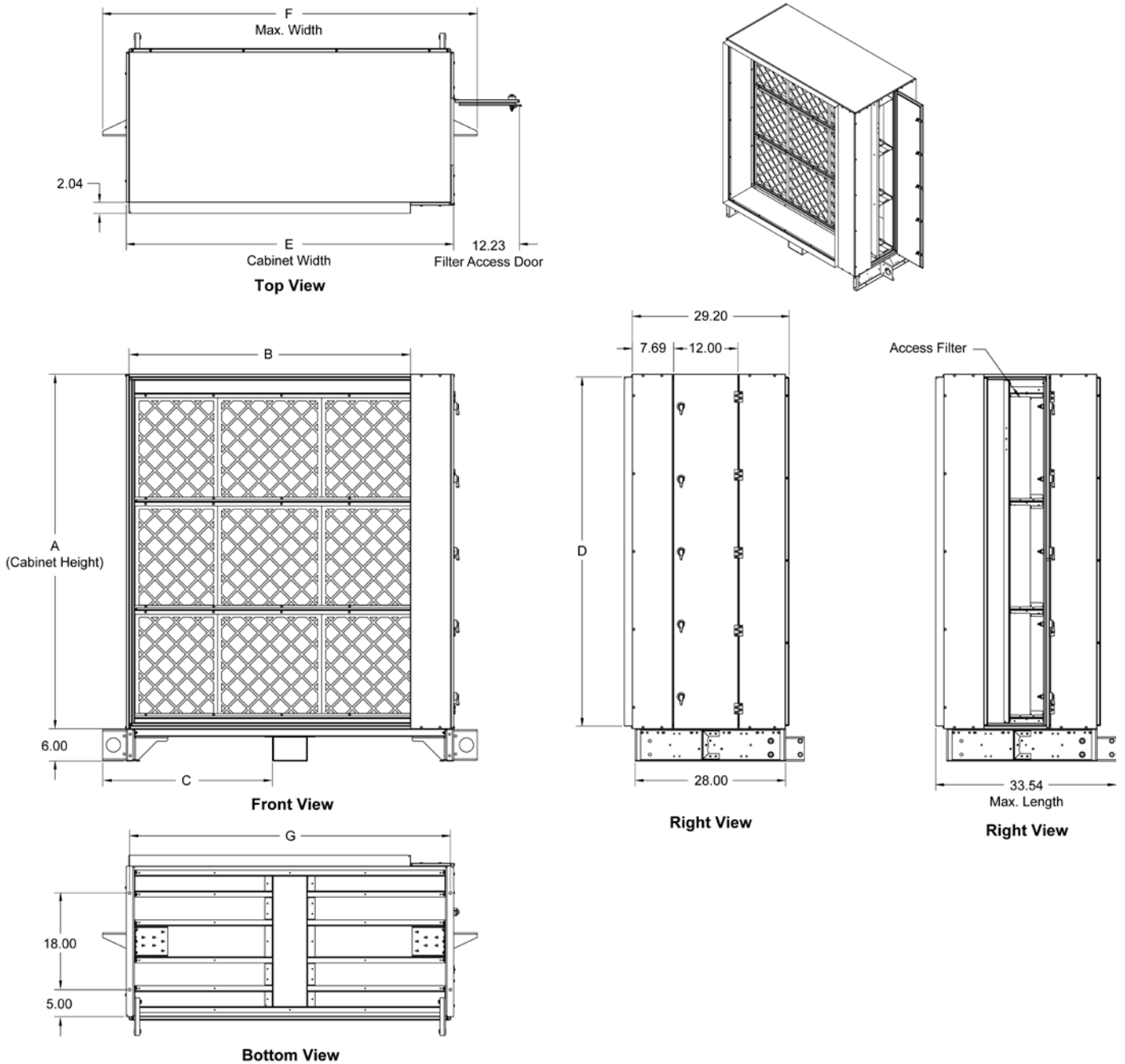


Table 66: Return Filter Section Dimension Letter Reference

Dimension	060	080	100
A	54.00	62.00	66.00
B	45.36	45.36	52.36
C	28.13	28.13	31.63
D	52.88	60.88	64.88
E	54.00	54.00	61.00
F	62.75	62.75	69.75
G	52.76	52.76	59.76

Figure 57: Electric Heat Section Dimensions (Sizes 060-100)

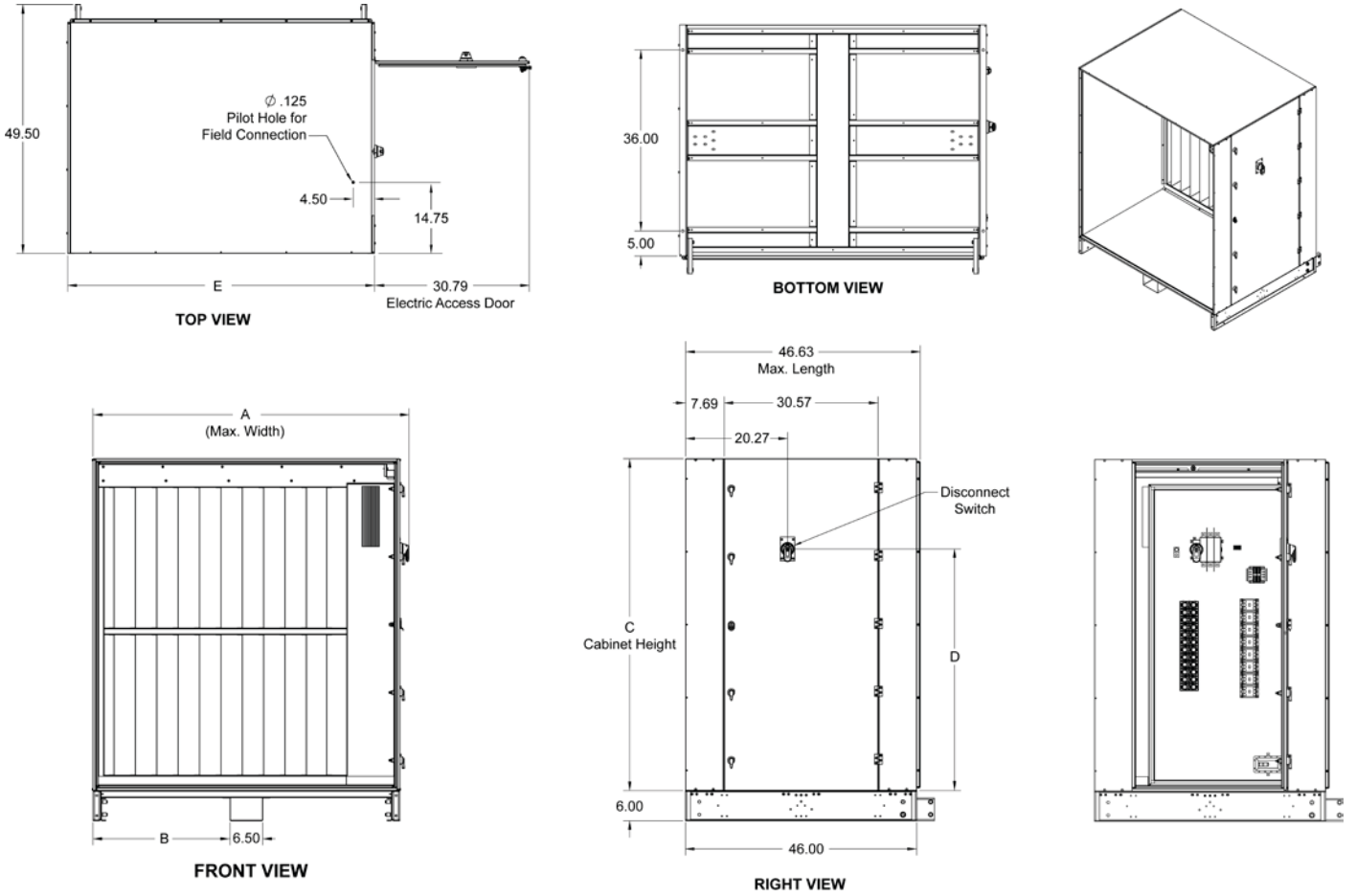


Table 67: Electric Heat Section Dimension Letter Reference

Dimension	060	080	100
A	55.82	55.82	62.82
B	23.75	23.75	27.25
C	54.00	62.00	66.00
D	36.04	44.04	46.73
E	54.00	54.00	61.00

Figure 58: Supply Air Fan Section Dimensions (Sizes 060-100)

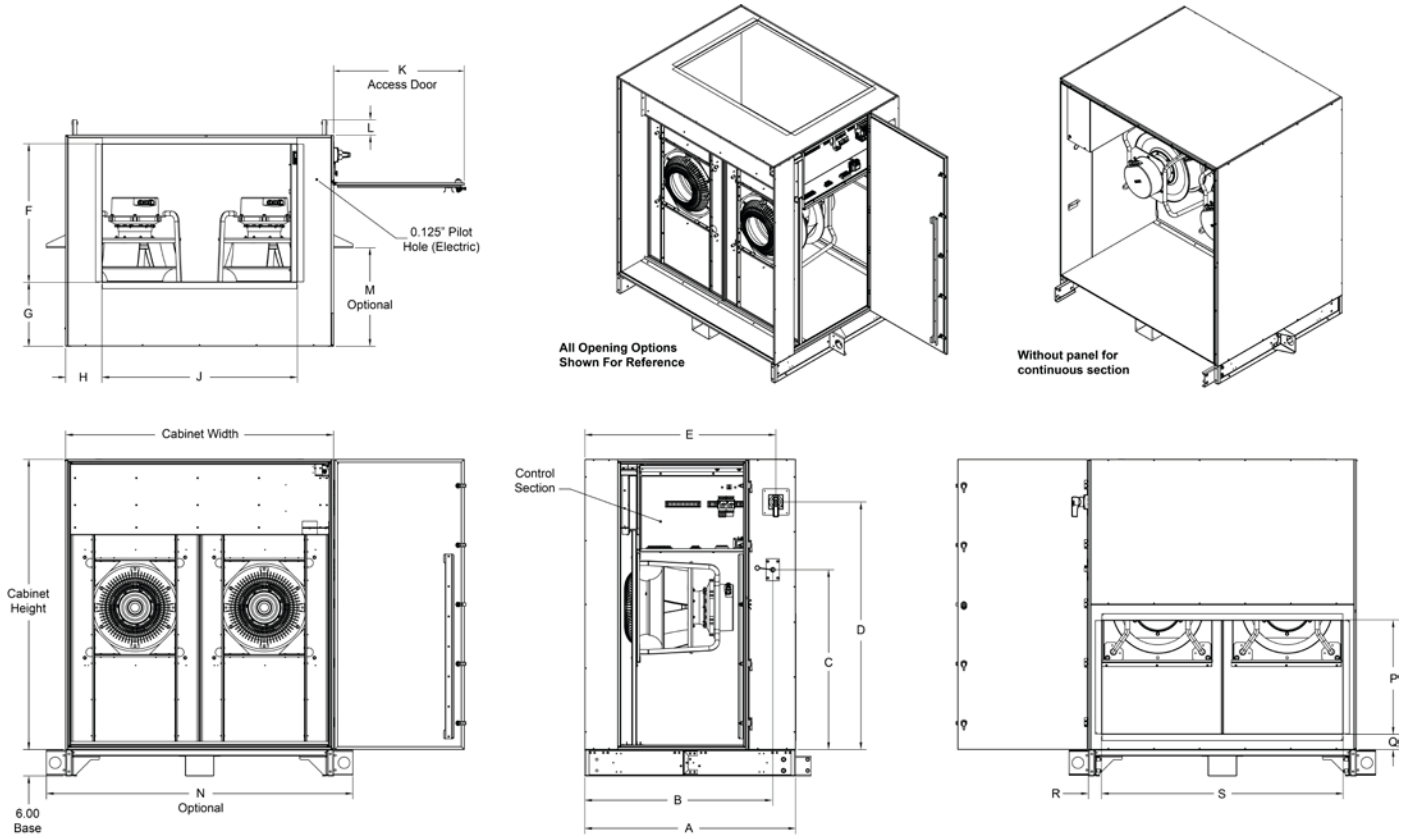


Table 68: Supply Air Fan Section Dimension Letter Reference

Dimension	060	080	100
A	48.00	48.00	48.00
B	43.65	43.65	43.65
C	36.65	44.64	48.64
D	44.08	52.08	56.07
E	43.65	43.65	43.65
F	29.50	31.00	31.38
G	15.87	14.37	14.57
H	12.25	8.50	8.31
J	29.50	37.00	44.38
K	29.73	29.73	29.73
L	3.50	3.50	3.50
M	22.39	22.39	22.39
N	62.75	62.75	69.75
P	20.00	26.00	26.00
Q	3.49	2.49	3.46
R	5.50	5.00	3.00
S	43.00	44.00	55.00

# Guide Specifications

## Part 1: General

### 1.01 Section Includes

- A. Horizontal Air Handler
- B. Vertical Air Handler

### 1.02 References

- A. Load ratings and fatigue life for ball bearings.
- B. Standards handbook.
- C. Laboratory methods of testing fans for rating purposes.
- D. Test code for sound rating air moving devices.
- E. Test methods for louver, dampers, and shutters.
- F. Room fan coil unit.
- G. Standard practice for operating salt spray apparatus.
- H. Motors and generators.
- I. National electrical code.
- J. HVAC duct construction standards - metal and flexible
- K. Test for surface burning characteristics of building materials.
- L. Test performance of air filter units.
- M. Standard for heating and cooling equipment.
- N. Test for flammability of plastic materials for parts in devices and appliances.

### 1.03 Submittals

- A. Shop Drawings: Indicate assembly, unit dimensions, weight loading, required clearances, construction details, field connection details, and electrical characteristics and connection requirements.
- B. Product Data:
  - 1. Provide literature that indicates dimensions, weights, capacities, ratings, fan performance, gauges and finishes of materials, and electrical characteristics and connection requirements.

### 1.04 Operation and Maintenance Data

- A. Maintenance Data: Include instructions for filter replacement.

### 1.05 Qualifications

- A. Manufacturer: Company specializing in manufacturing Air Handler products specified in this section must show a minimum five years documented experience and complete catalog data on total product.

### 1.06 Delivery, Storage, and Handling

- A. Deliver, store, protect and handle products to site.
- B. Accept products on site wrapped in protective [cardboard wrap] [weather-resistant wrap]. Inspect for damage.

- C. Store in a clean dry place and protect from weather and construction traffic. Handle carefully to avoid damage.

### 1.07 Environmental Requirements

- A. Do not operate units for any purpose, temporary or permanent, until ductwork is clean, filters are in place, and fan has been test run under observation.

## Part 2: Products

### 2.01 Manufacturers

- A. The following manufacturers are approved for use. No substitutions will be permitted.
  1. Daikin Applied – “PreciseLine” air handler is the basis of design, including standard product features and all special features required per plans and specifications.

### 2.02 Fan Coil Type And Arrangement

- A. The unit shall be furnished as a draw-through style air handler.
- B. A Primary hydronic cooling coil shall be furnished and factory-installed.
- C. [DX][VRV] cooling coils shall be factory-installed. Maximum operating pressure should not exceed 500 psig (3447 kPa).
- D. A Secondary electric-resistive heater shall be factory-furnished [upstream][downstream] of the primary coil. Automatic and manual-style thermal cut-out switches shall be furnished and installed by the manufacturer. The switches will disconnect the electric heater at air temperatures unsafe for the unit’s continued operation.
- E. A Secondary [preheat][reheat] hydronic coil located [upstream][downstream] of the primary coil shall be factory-furnished. Entering water conditions are not to exceed 200°F.
- F. A Secondary preheat steam coil located upstream of the primary coil shall be factory-furnished. Operating pressure should not exceed 25 psig (172 kPa).

### 2.03 General Construction

- A. The air handling unit shall include a blower, fan housing, coil, and drain-pan enclosed within and mounted to a rigid cabinet. Steel parts exposed to moisture shall be galvanized and insulated to prevent condensation. The complete fan assembly shall be wired via quick connect electrical contacts and easily removable for service and maintenance.
- B. The air handling unit shall include a blower, fan housing, coil, and drain-pan enclosed within and mounted to a rigid cabinet. Steel parts exposed to moisture shall be galvanized and insulated to prevent condensation.
- C. Cabinet
  1. Unit will be supplied with 1-inch, double-wall panels. The cabinet is to be thermally isolated through injected foam insulation inside each cabinet. Single wall cabinets with fiberglass insulation exposed in the airstream are not acceptable. Frame channels which allow heat conductance between the inside and outside of the cabinet are not acceptable. Base rails used for unit mounting/hanging are acceptable. Panel shall have a minimum thermal insulation of R-6.5. Foam injected insulation conforms to:
    - a. ASTM C1071 (including C665)
    - b. UL 181 for erosion

- c. 25/50 rating for flame spread/smoke developed per ASTM E-84, UL 723 and NFPA 90A

### 2.04 Supply Fan(s)

- A. Supply fans shall be a [DWDI forward-curved type] [welded aluminum airfoil plenum type] fan. Fan assemblies shall be balance tested dynamically by the manufacturer. Manufacturer must ensure maximum fan RPM is below the first critical speed.
- B. The complete fan assembly, including motor and main drain pan shall be easily removable.
- C. Fan motor(s) assembly shall be direct-drive style and not include belts, pulleys, or sheaves.
- D. Fan motor(s) shall be of Direct Current Brushless type or minimum motor efficiency of 85 percent when rated in accordance of NEMA Standard MG 1-2016 at full load conditions.
- E. Manufacturer’s supply fan motor must have means to adjust motor speed for field balancing.
- F. Units shall be certified in accordance with the Central Station Air Handler certification program that is based on AHRI Standard 430.
- G. [Forward-curved fan must be capable of delivering 1.5" w.g. external static pressure and 3.0" w.g. total static pressure at nominal cabinet CFM.]
- H. [Welded aluminum airfoil plenum fan must be capable of delivering 5.0" w.g. total static pressure at nominal cabinet CFM.]

### 2.05 Exhaust Fan(s)

- A. [1][2][3] exhaust fans shall be a DWDI forward-curved type. Fan assemblies shall be balance tested dynamically by the manufacturer. Manufacturer must ensure maximum fan RPM is below the first critical speed.
- B. The complete fan assembly, including motor, shall be easily removable.
- C. Fan motor(s) assembly shall be direct-drive style and not include belts, pulleys, or sheaves.
- D. Fan motor(s) shall be of Direct Current Brushless type or minimum motor efficiency of 85 percent when rated in accordance of NEMA Standard MG 1-2016 at full load conditions.
- E. Manufacturer’s supply fan motor must have means to adjust motor speed for field balancing.
- F. Exhaust fan must be capable of delivering 0.5" w.g. external static pressure at 50% nominal unit airflow.

### 2.06 Filters

- A. Draw-through filter section shall be a [2"] [4"] [flat] [angle] type furnished with [MERV 8] [MERV 11] [MERV 13] deep -pleated panel filters.
- B. Final filter section shall be a 4" flat type furnished with [MERV 8][MERV13] deep-pleated panel filters.
- C. Filter media shall be UL 900 listed, Class I or Class II.
- D. Filters shall be easily accessible via a door or panel located on the [side][top][front][bottom] of the unit.

- E. The [draw-through][final] filter shall be of disposable type and rating of MERV [8][13].

## 2.07 Electrical

- A. Supply fans shall be driven by Electrically Commutated motors that are run-tested in the assembled unit and permanently lubricated. All motors shall have integral thermal overload protection with a maximum ambient operating temperature of 55°C. Motors shall be capable operating at 90 percent of rated voltage on all speed settings. Motors can operate up to 10 percent overvoltage.
- B. Supply fans shall be driven by NEMA Premium Efficiency motors that are run-tested in the assembled unit and permanently lubricated. All motors shall have integral thermal overload protection with a maximum ambient operating temperature of 40°C. Motors shall be capable of operating 90 percent of rated voltage on all speed settings. Motors can operate up to 10 percent overvoltage.
- C. Motor wires shall include a quick-disconnect motor plug.
- D. All controls equipment including ECM control module, low voltage transformers, safety switches, disconnects, fusing, and terminal strips must be located inside the main unit cabinet.

## 2.08 Cooling and Heating

- A. Cooling Coil
  - 1. Cooling performance shall be as specified on the unit schedule.
  - 2. [Water coil][Direct expansion][VRV] fins shall have full drawn collars to provide a continuous surface cover over the entire tube for maximum heat transfer. Seamless copper tubes shall be mechanically expanded into the fins to provide a continuous primary-to-secondary compression bond over the entire finned length for maximum heat transfer rates. Bare copper tubes shall not be visible between fins. Coil casing shall be constructed of [galvanized][stainless] steel.
  - 3. Water coils shall be provided with headers of seamless copper tubing with intruded tube holes to permit expansion and contraction without creating undue stress or strain. Coil connections shall be [female pipe thread] [sweat] with connection size to be determined by manufacturer based upon the most efficient coil circuiting. Vent and drain connections shall be furnished on the coil connection, easily accessible inside the cabinet. Vent connections to be provided at the highest point to assure proper venting. Drain connections shall be provided at the lowest point.
  - 4. Direct Expansion coils shall be provided with a distributor. The return coil connection shall be a sweat connection with size to be determined by

manufacturer based upon the most efficient coil circuiting.

- 5. All steel parts exposed to moisture shall be galvanized.
- 6. Unit shall include a stainless steel primary drain pan and a [galvanized][stainless] steel secondary drain pan. The primary drain pan shall be positively sloped in every plane. Primary and secondary drain pans to be insulated with anti-microbial closed-cell insulation. The drain pan shall be designed to ensure no pooling of condensate water per ASHRAE 62.2.
- 7. Coils shall have stub-outs off of the headers extending through the unit paneling.
- 8. Coils shall have stub-outs off the headers that end within the internal cabinet.
- B. Heating Coil
  - 1. Heating performance shall be as specified on the unit schedule.
  - 2. [Hot water coil][Steam coil] fins shall have full drawn collars to provide a continuous surface cover over the entire tube for maximum heat transfer. Seamless copper tubes shall be mechanically expanded into the fins to provide a continuous primary-to-secondary compression bond over the entire finned length for maximum heat transfer rates. Bare copper tubes shall not be visible between fins.
  - 3. Coils shall be provided with headers of seamless copper tubing with intruded tube holes to permit expansion and contraction without creating undue stress or strain. Coil connections shall be [female pipe thread][sweat] connections with connection size to be determined by manufacturer based upon the most efficient coil circuiting. Vent and drain connections shall be furnished on the coil connection, external to the cabinet. Vent connections shall be provided at the highest point to ensure proper venting. Drain connections shall be provided at the lowest point.

## 2.09 Discharge Plenum

- A. A factory-installed discharge plenum is to be furnished attached to the main unit. This component must be constructed of a similar cabinet paneling to the main unit.
- B. A factory-provided discharge plenum is to be furnished for attachment to the main unit (Vertical units Size 30+). This component must be constructed of a similar cabinet paneling to the main unit.
- C. Sound-absorbing material will be affixed to the internal walls of the discharge plenum.



## 2.10 Economizer / Mixing Box

- A. A factory-installed mixing box for mixing two separate airstreams is to be furnished attached to the main unit. This component must be constructed of a similar cabinet that the main unit is constructed of.
- B. An economizer section shall be provided, controlling return, exhaust, and outdoor air.
- C. Dampers intended for modulating each airstream are to be furnished to cover the openings of the supplied mixing box. Return and outdoor air dampers shall be controlled independently (sizes 060-100).
- D. Damper blades shall be of airfoil construction. Dampers shall be AMCA Class 1-A leakage rated (sizes 060-100).
- E. Damper blades shall be interoperable via linkage shaft. Gear linkage dampers shall not be acceptable.
- F. Damper actuators are to be furnished factory-installed on the mixing box. These actuators are to be controlled via [24 VAC ON/OFF signal][0-10V modulating signal] and factory-wired back to the control area within the main cabinet.

## 2.11 Valve Packages

- A. Coils
  - 1. Fan coil units shall be provided with factory-installed valve / piping package(s) available for the [primary coil][primary and secondary coils]. All piping packages shall be factory assembled and tested at 400 psig (2760 kPa) and re-tested for leak when factory soldered to the coil(s) at 300 psig (2100 kPa) Maximum Working Pressure of the piping package shall be 300 psig (2100 kPa).
  - 2. The valve package(s) shall be designed so that any condensation is directed into the secondary drain pan. With the secondary drain pan provided, insulation of the piping package is not required.
- B. Type and Components
  - 1. The valve package(s) shall be [Basic, Deluxe] type and provided with:
    - a. Interconnecting copper piping and shut-off ball valves.
    - b. Connecting supply and return lines to the unit. Four-pipe packages shall include a venting valve for the secondary coil.
    - c. (Deluxe package only) An automatic circuit setter. The circuit setter includes a cartridge within the valve body that is sized to allow a specific flow rate through the coil. This valve sets flow through the coil without any action required by a system piping balancer.
    - d. P/T ports to measure the temperature or pressure drop across the valve. This pressure drop can be compared to factory-supplied curves that relate the pressure drop to a

specific flow rate.

- e. Unions on the valve package that allow the coil and valve package to be separated and removed from the unit.
  - f. A 20 mesh strainer on the supply side that is easily removed for cleaning, with a blow-off valve. The strainer shall have a pressure rating of up to 400 psig (2,700 kPa).
  - g. Isolating ball valve on the supply side.
  - h. Two-Way valve body(s) positioned on the return side of the coil. A method to relieve pump head pressure to be employed when two-way systems are selected.
  - i. Three-Way, mixing-style valve body(s) to be positioned on the return side of the coil.
- C. Control
    - 1. The valve package is to be furnished with two-position On/Off valve actuators.
    - 2. The furnished actuators are to be controlled via 24 VAC control signal.
  - D. Control
    - 1. The valve package is to be furnished with proportional modulating actuators.
    - 2. The furnished actuators are to be controlled via 0-10 VDC control signal.

## 2.12 Controls

- A. Unit shall be supplied with a digital controls ready interface. This interface is to be located inside the control box internal to the main unit. This interface shall include a 24 VAC transformer and terminal blocks for connections to fan motor control, sensor control, safety switches, valve actuators, and damper control if applicable. (Code 43 = "D")
  - a. [Fan motor control to be furnished as 0-10VDC. (Code 46 = "M")] [(Only available on sizes 006-020) Fan Motor Control to be furnished as three speed. These three speeds are field adjustable for precise air flow scheduling. (Code 46 = "T")]
- B. [Unit shall be supplied with factory-installed and configured integrated controls.
  - a. The controller shall control discharge air temperature based on return air temperature, space temperature, or an average of the two.
  - b. The controller shall allow separate setpoints based on cooling, heating, and dehumidification setpoints for occupied, unoccupied, and standby modes.
  - c. Controller shall allow for active dehumidification via reheat coil or passive dehumidification via reduced-speed fan operation. Dehumidification shall control via relative humidity or dewpoint setpoint.
  - d. Sensors shall be provided for space



- temperature, discharge air temperature, entering water OR discharge coil temperature, outdoor air temperature, space humidity, duct static pressure, outdoor air humidity, condensate overflow, freeze protection, airflow proving switch, return air temperature, return air humidity, and dirty filter switch.
- e. Supply fan shall be controlled to [constant speed] [duct static pressure] [single-zone VAV operation].
  - f. The controller shall be configurable to operate with a CO<sub>2</sub> sensor provided as an accessory, to provide CO<sub>2</sub>-based demand control ventilation (unit sizes 060-100 only). The supply fan shall cycle with demand or operate continuously.
  - g. Exhaust fan shall control to [an offset of supply fan tracking] [a constant speed].
  - h. Outdoor air damper shall have a programmable minimum opening position.
  - i. [The economizer shall be equipped with Title-24 compliant fault detection and diagnostics. Economizer shall be controlled via [outdoor air temperature] [outdoor enthalpy] [comparative indoor/outdoor temperature] [comparative indoor/outdoor enthalpy].] The controller can be field-programmed for optional outdoor air temperature economizer lock-out.]
  - j. The controller shall be factory configured to control 2-pipe/4-pipe heating or cooling, reverse pipe or direct acting via 24 VAC On/Off or [0][2]-10 modulating valve control. Entering water temperature sampling for 2-pipe changeover configurations.
  - k. The controller shall be factory configured to control [1-stage][4-stage][SCR] electric heat.
  - l. The controller shall feature a startup test operation mode in which setpoints may be set outside of standard operation to confirm component operation.
  - m. The controller shall provide run-time totalization for filter, supply fan, exhaust fan, compressor startup totalization and runtime, and compressor runtime control.
  - n. Controller shall provide dirty filter notification based on fan time or differential filter pressure switch.
  - o. Controller shall have a 30-event alarm history available to support field troubleshooting.
  - p. The controller shall have an internal time clock with 7-day programmable schedule.
  - q. Controller shall allow [Configurable compressor on/off times as well as configurable controller interstage time and PID loop for 4-stage compressors and discharge air temperature control.]
  - r. Network communication shall enable read/write functionality of control points, including space temperature, CO<sub>2</sub> value, space relative humidity, entering water, fan speed, outdoor air temp, OA relative humidity, network enabling/disabling of economizer/cooling/heating/dehumidification.
- B. Unit shall be furnished with a disconnect switch. The disconnect switch shall be operable from the outside of the cabinet to reduce hazards during field service and commissioning. (Code 42 = "D")
  - C. Unit shall be furnished with a disconnect switch and inline fusing to protect vital electrical components. The disconnect switch shall be operable from the outside of the cabinet to reduce hazards during field service and commissioning. (Code 42 = "F")

## Part 3: Execution

### 3.01 Installation

- A. The air handling unit shall be installed per manufacturer's Installation & Maintenance Manual.
  - 1. Selected field mounted kits shall be specified on the unit schedule and installed per manufacturer's instruction.





### ***Daikin Applied Training and Development***

Now that you have made an investment in modern, efficient Daikin branded equipment, its care should be a high priority. For training information on all Daikin HVAC products, please visit us at [www.DaikinApplied.com](http://www.DaikinApplied.com) and click on Training, or call 540-248-9646 and ask for the Training Department.

### ***Warranty***

All Daikin branded equipment is sold pursuant to its standard terms and conditions of sale, including Limited Product Warranty. Consult your local Daikin Applied representative for warranty details. To find your local Daikin Applied representative, go to [www.DaikinApplied.com](http://www.DaikinApplied.com).

### ***Aftermarket Services***

To find your local parts office, visit [www.DaikinApplied.com](http://www.DaikinApplied.com) or call 800-37PARTS (800-377-2787). To find your local service office, visit [www.DaikinApplied.com](http://www.DaikinApplied.com) or call 800-432-1342.

This document contains the most current product information as of this printing. For the most up-to-date product information, please go to [www.DaikinApplied.com](http://www.DaikinApplied.com).

Products manufactured in an ISO Certified Facility.