



Catalog 1112-18

Enfinity™ Large Capacity Horizontal Water Source Heat Pumps

CCH Standard Range & CCW Geothermal Range

Unit Sizes 072 – 120 (6 to 10 Tons) • R-410A Refrigerant



Model Nomenclature	4	Typical hot gas reheat refrigeration cycle – dual compressors	21
AHRI Performance Data	5	Systems	22
Introduction	6	Capacity Data	24
Large capacity horizontal water source heat pumps - models CCH & CCW sizes 072-120 (6 to 10 tons)	6	Size 072 (2400 SCFM)	24
Design Features & Options	7	Size 096 (3000 SCFM)	26
Cabinet construction	8	Size 120 (4000 SCFM)	28
Refrigeration system	8	Engineering Data	31
Thermal expansion valve	8	Physical data	32
Fan section	8	Electrical data	32
Factory installed options	8	Operating limits	33
Hot gas reheat coil	9	Airflow correction factors	34
Hot gas bypass	9	Antifreeze correction factors	34
Boilerless heat control (field installed)	9	Fan performance curves	35
Controls Features & Options	10	Dimensional Data	37
MicroTech® III controller with LONWORKS® or BACnet® communication module	16	CCH/CCW large horizontal – 072 & 096	37
MicroTech III LONWORKS communication module	16	CCH/CCW large horizontal – 120	38
MicroTech III BACnet communication module	16	Hanger brackets	39
Accessories	17	Typical WSE field provided and installed jumper piping routing details	40
Supply and return water hoses	17	Typical Wiring Diagrams	41
Condensate hose kit	17	Control Accessories	45
Combination balancing and shutoff (ball) valves	17	Thermostats and Remote Indoor Sensor	45
Motorized valve	17	Room Temperature Sensors	46
Applications	18	Engineering Specifications	47
Typical horizontal installation	18		
Piping	18		
Condensate drain piping	18		
Ductwork and attenuation	19		
Typical cooling and heating refrigeration cycles – dual compressors	20		

©2024 Daikin Applied, Minneapolis, MN. All rights reserved throughout the world. This document contains the most current product information as of this printing. Daikin Applied Americas Inc. has the right to change the information, design, and construction of the product represented within the document without prior notice. For the most up-to-date product information, please go to www.DaikinApplied.com.

™ MicroTech and Daikin Applied are trademarks or registered trademarks of Daikin Applied Americas Inc. The following are trademarks or registered trademarks of their respective companies: BACnet from American Society of Heating, Refrigerating and Air-Conditioning Engineers, Inc.; Echelon, LonWorks, LonMark, and LonTalk from Echelon Corporation; Modbus from Schneider Electric; and Windows from Microsoft Corporation.

Category	Code Item	Code Position	Code Designation & Description
Product Category	01	1	W = Water Source Heat Pump
Product Identifier	02	2-4	CCH = Large Horizontal, Standard Range CCW = Large Horizontal, Geothermal Range
Design Series (Vintage)	03	5	2 = Design Series 2
Nominal Capacity	04	6-8	072 = 72,000 Btuh Nominal Cooling 096 = 96,000 Btuh Nominal Cooling 120 = 120,000 Btuh Nominal Cooling
Control Board Option	05	9	B = MicroTech® III Unit Controller A = DDC-Less Board (Alerton Rep Option)
Network Module Option	06	10	L = LON Module B = BACnet Y = None
Condensate Overflow Protection	07	11	S = Standard Overflow Sensor
Current Sensing Switches	08	12	Y = None
Freeze Fault Protection	09	13	F = Freeze Fault Protection
Voltage	11	15	F = 208/230-60-3 K = 460-60-3 L = 575-60-3
Options	12	16	Y = None P = Phase Monitor
Return Air	13	17	L = Left Hand Return Air
Discharge Air	14	18	E = End Discharge S = Straight Discharge
Blower Motor	15	19-20	01 = Belt Drive – Integral HP Motor 02 = High Static 03 = Ultra High Static 11 = Standard with VFD 12 = High Static with VFD 13 = Ultra High Static with VFD
Construction Type	17	23	A = Standard 1/2" Fiberglass Insulation B = Closed Cell Foam Insulation F = Standard 1/2" Fiberglass Insulation w/Compressor Sound Blankets G = Closed Cell Foam Insulation w/Compressor Sound Blankets
Water To Refrigerant Heat Exchanger Construction	18	24	C = Copper Inner Tube - Steel Outer Tube S = Cupro-Nickel Inner Tube - Steel Outer Tube
Options	20	26-27	AA = Hot Gas Reheat (<i>Not to be combined with WSE</i>) AB = Hot Gas Bypass YY = None
Piping Hand	21	28	R = Right Side Pipe Connections
Filter Options	23	32-34	SD2 = Standard 2" Disposable filter M08 = Merv 8 in 2" frame M13 = Merv 13 in 4" frame N02 = No Filter with 2" Filter Rack (Low Leak) N00 = No Filter-No Filter Rack
Refrigerant	26	40	A = R-410A
Condensate Drain Pan	27	41-42	GL = Galvanized Steel SS = Stainless Steel
Control Transformer Option	29	44-46	075 = 75VA Control Transformer
Waterside Economizer	35	59	1 = Water Side Economizer w/Motorized Valve Control (<i>Not to be combined with HGRH</i>)



Table 1: Water loop (rated in accordance with AHRI/ASHRAE/ISO 13256-1)

In English (IP) Units				Cooling		Heating	
Large Horizontal				EWT 86°F		EWT 68°F	
Unit Size	Airflow CFM	Fluid Flow Rate GPM	Voltages	Capacity Btuh/hr	EER	Capacity Btuh/hr	COP
072	2400	20.1	208/230-60-3	80,000	15.5	83,000	4.6
			460-60-3				
			575-60-3				
096	3000	23.6	208/230-60-3	94,900	15.3	100,700	4.6
			460-60-3				
			575-60-3				
120	4000	30.1	208/230-60-3	123,000	15.0	136,000	4.9
			460-60-3				
			575-60-3				

Notes: 1. Cooling capacity is based on 80.6°F db, 66.2°F wb (27/19°C) EAT and 86°F (30°C) EWT.
 2. Heating capacity is based on 68°F db, 59.0°F wb (20/15°C) EAT and 68°F (20°C) EWT.

Table 2: Ground loop (rated in accordance with AHRI/ASHRAE/ISO 13256-1)

In English (IP) Units				Cooling		Heating	
Large Horizontal				EWT 68°F		EWT 32°F	
Unit Size	Airflow CFM	Fluid Flow Rate GPM	Voltages	Capacity Btuh/hr	EER	Capacity Btuh/hr	COP
072	2400	20.1	208/230-60-3	80,100	17.1	58,700	3.8
			460-60-3				
			575-60-3				
096	3000	23.6	208/230-60-3	97,300	17.1	70,800	3.6
			460-60-3				
			575-60-3				
120	4000	30.1	208/230-60-3	125,800	16.7	94,100	3.9
			460-60-3				
			575-60-3				

Notes: 1. Cooling capacity is based on 80.6°F db, 66.2°F wb (27/19°C) EAT and 77°F (25°C) EWT at full load or 68°F (20°C) at part load.
 2. Heating capacity is based on 68°F db, 59.0°F wb (20/15°C) EAT and 32°F (0°C) EWT at full load or 41°F (5°C) at part load.

Large capacity horizontal water source heat pumps - models CCH & CCW sizes 072-120 (6 to 10 tons)

- Model CCH (standard range: 55°F to 110°F)
- Model CCW (geothermal range: 30°F to 110°F)



Daikin 6- to 10-ton horizontal units have a common cabinet size and common water, condensate, and duct connection locations for easier and more efficient installation. The cabinet is constructed of unpainted, G-60 galvanized steel. Large panels provide access to the fan/motor compartment and the compressor/control compartment. The interiors of the top and side panels and the bottom of the unit are covered with 1/2" thick, 1½ lb. dual-density fiberglass insulation. The filter is supported by a factory-mounted combination filter rack and return air duct collar, eliminating the need for field-mounted brackets. The water and condensate connections protrude through the outside of the cabinet. The water connections are FPT type for easy connection to flexible stainless steel hoses. The large condensate connection provides effective condensate removal. The electrical components are located in the compressor section of the unit. Holes are provided on the cabinet to facilitate main power and low voltage control wiring through separate holes. All wiring connections are made internal to the cabinet for maximum safety. Each unit is rated to accept time delay fuses for branch circuit and is protected by a resettable circuit breaker. The standard control for all large capacity units is the MicroTech® III unit controller. The unit controller receives its power from the 75VA control transformer. A LonWorks® or BACnet® communication module is available as an option.

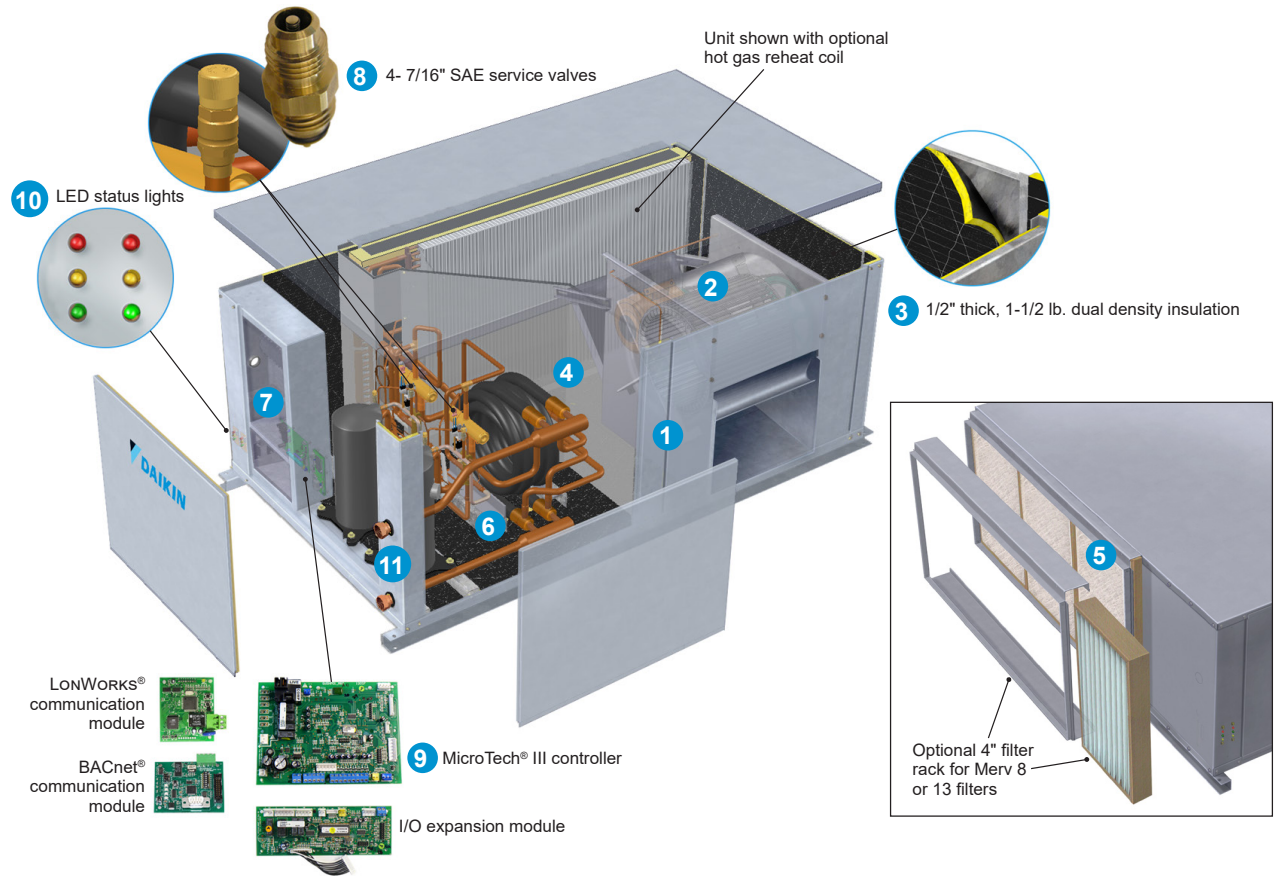

1 Cabinet

- Robust heavy gauge G-60 galvanized steel for long term equipment protection and superior sound attenuation

2 Fan section

- A forward curved, DWDI fan, solid steel shaft mounted in ball bearings. Motor to be three phase, Open- Drip Proof (ODP) type with variable pitch sheave and adjustable base

3 Insulation

- All interior framework and panels are lined with 1/2" thick, 1½ lb. dual-density fiberglass insulation. Optional (IAQ) closed-cell foam insulation

4 Drain pan

- Heavy-gauge, insulated, galvanized steel or optional stainless steel

5 Filters

- Standard 2" factory-installed filter rack with 2" disposable filters. Filter rack outfitted with duct collar. Optional 4", filter rack for Merv 8 or 13 filters

6 Refrigerant circuit

- All units have a dual refrigerant circuit with scroll compressors, thermal expansion valve, coaxial heat exchanger, finned tube airside coil, reversing valve and service valves

7 Electrical

- The control enclosure includes components necessary for proper unit operation. These components include, but not limited to: fan relay, compressor contactors, 24 VAC control transformer and control circuit boards

8 Service valves connections

- Four service valves are located inside the end access panel – one on the low side and one on the high side of the refrigeration circuit – for charging and servicing. All valves are 7/16" SAE fittings

9 MicroTech® III controller

- Designed for flexibility, the control board is used in standalone applications in conjunction with the I/O expansion module for control of the second refrigerant circuit. A separate LONWORKS or BACnet communication module can be easily snapped onto the Microtech III board to allow communication with a building automation system. The control system accommodates the use of a two-stage heat/two-stage cool 7-day programmable or non-programmable wall-mounted thermostat, offered as a field-installed option. Sensors are available for building automation system applications

10 LED annunciators

- External LED status lights display fault conditions to provide easy troubleshooting and diagnosis, visible without removing the access panel

11 External pipe connections

- Supply and return pipe connections located outside the cabinet make pipe connections easy without removing access panels

Cabinet construction

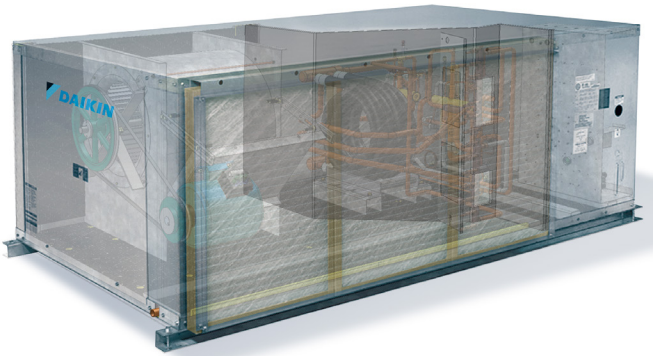

Daikin 6- to 10-ton horizontal units have a common cabinet size and common water, condensate, and duct connection locations for easier and more efficient installation. The cabinet is constructed of heavy-gauge G-60 galvanized steel. Large panels provide access to the fan/motor compartment and the compressor/control compartment. The interiors of the top and side panels and the bottom of the unit are covered with 1/2" thick, 1½ lb. dual-density fiberglass insulation. Closed-cell foam (IAQ) insulation is available as a selectable option, suitable for fiberglass-free applications. The filter is supported by a factory-mounted combination filter rack and return air duct collar, eliminating the need for field-mounted brackets. The water and condensate connections protrude through the outside of the cabinet. The water connections are FPT type for easy connection to flexible hoses. The large condensate connection provides effective condensate removal. The electrical components are located in the compressor section of the unit. Holes are provided on the cabinet to facilitate main power and low voltage control wiring through separate holes. All wiring connections are made internal to the cabinet for maximum safety. Each unit is rated to accept time delay fuses for branch circuit and is protected by a resettable circuit breaker.

Refrigeration system

Units have a dual circuit design and the two circuits operate independently to enable load shedding when conditions allow. Each circuit employs a random start feature to prevent both compressors from energizing simultaneously after an "unoccupied" cycle. Units contain two of each refrigerant system component, including high efficiency compressors, coaxial heat exchanger with a copper inner tube and steel outer tube, reversing valves, expansion valves, high/low side refrigerant service valves, and required safety controls. Large access panels are provided for easy service access to any of these components. The reversing valves are energized in the heating mode and will "fail-safe" to the cooling mode, which is the predominant mode of operation.

The air-to-refrigerant coil is a dual circuit coil on one slab. The fins are lanced and the tubes have finned edges on the inside to enhance heat transfer capabilities. Geothermal range units include coil and piping insulation to protect against condensation in low temperature geothermal applications.

Safety controls include low suction temperature (freeze-stat) and high pressure switches to lock out compressor operation at extreme conditions. The safety controls can only be reset from the main disconnect switch - not from the wall thermostat.

For additional safety, each unit has a low pressure switch to protect the compressor from low refrigerant charge. The low setting prevents nuisance trips while providing adequate protection.

Thermal expansion valve

Units include a Thermal Expansion Valve (TXV) for refrigerant metering. The TXV allows the unit to operate at optimum efficiency with fluid temperatures ranging from 30°F to 110°F (geothermal capable units only) and entering air temperatures ranging from 55°F to 90°F. The TXV precisely meters the exact amount of refrigerant flow through the system to meet the load and deliver rated heating and cooling capacity.

Fan section

The fan section includes the fan housing, fan wheel, fan motor, adjustable sheave, high strength V-belt, and drain pan. The standard drain pan is made of G-60 galvanized steel and is insulated from the cabinet. A stainless steel drain pan is available as an option. The pan has ample height to allow self-priming of the condensate trap. The fan motor is belt driven with an adjustable sheave for field adjustment. The motor is isolated from the fan housing to minimize vibration transmission to the cabinet. The fan housing protrudes through the cabinet to provide adequate material to connect to a field-provided flexible duct collar. The fan discharge can exit from the end or the side of the unit and must be configured at the factory.

Factory installed options

Geothermal range units are available for applications requiring heating operation at reduced entering conditions. The geothermal range unit will operate at 25°F (5°C) minimum entering water temperature, 40°F (5°C) minimum entering air temperature.

The optional Variable Frequency Drive (VFD) provides adjustable speed control of a single fan motor. Factory installed internally in the cabinet fan section, the VFD provides not only a lower cost compared to field installation, but also an optimal installation location. The VFD is preprogrammed and includes a keypad for local or remote control.

Hot gas reheat coil

For improved indoor climate control, Daikin Applied offers accurate and cost effective dehumidification control using a hot gas reheat coil. The hot gas reheat coil option is an excellent solution for applications where maintaining low humidity in a space is crucial. Once the space temperature is satisfied, the humidistat signal diverts the high temperature refrigerant gas to the reheat coil located downstream of the cooling coil. The conditioned and reheated air prevents over cooling of the space and maximizes moisture removal for improved indoor comfort. Under humid conditions (60%RH) and typical loop water temperatures, the latent capacity is optimized for approximately 90% of the sensible capacity. With loop water conditions of 85°F, the leaving air temperature is approximately the same as the entering air temperature, resulting in effective dehumidification without over cooling the space.

Figure 1: CCH unit with hot gas reheat (HGRH)

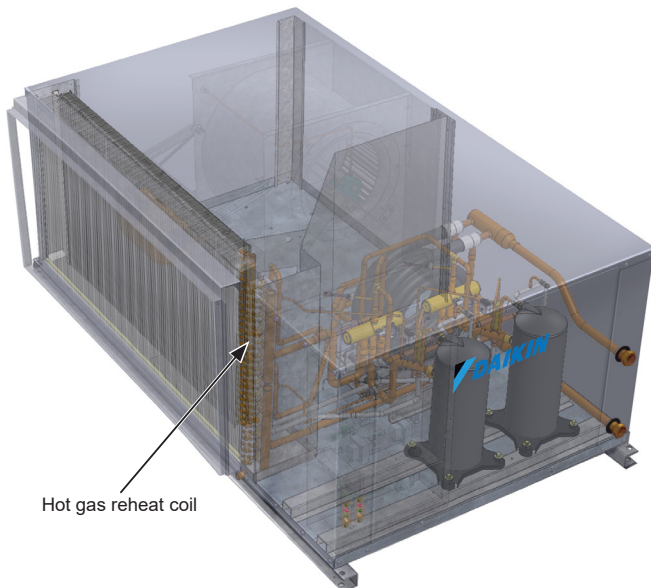

Waterside economizer

The waterside economizer option helps to reduce energy consumption by using cool loop water temperatures to condition a space without energizing mechanical cooling. Even in the coldest weather a space can experience a build-up of ambient heat from people, equipment, lighting and the sun. Buildings with temperature controlled computer rooms, media/resource rooms or medical equipment rooms, benefit from the waterside economizer when the geothermal loop field or cooling tower temperatures are cool enough to provide air conditioning.

The waterside economizer includes a hydronic cooling coil located upstream of the unit's evaporator coil and after the filter. When entering water temperatures are between 35° to 70°F, a multi-stage thermostat or room temperature sensor in conjunction with a factory-installed entering water temperature sensor and a 2-position 3-way diverting valve, determines when loop water can be diverted to the hydronic coil for economizer cooling. The MicroTech III controller determines if the economizer or mechanical cooling will be utilized. The controller also provides low temperature protection to avoid economizer operation when entering water temperatures are below 35°F.

Figure 2: CCH with waterside economizer coil option



Hot gas bypass

During cooling operation an external equalizer senses the suction pressure at the evaporator outlet. If the suction pressure drops below 115 psig the Hot Gas Bypass valve will begin to open and bypass hot discharge gas to the evaporator inlet, helping to prevent evaporator coil icing due to low suction pressure. The valve will continue to open as required to full capacity. As suction pressure rises to normal levels the HGBP valve will begin to close until normal cooling operation resumes.

Boilerless heat control (field installed)

When the entering water temperature is below setpoint, the compressors will not be allowed to operate. On an initial call for heating, the fan and electric heat will start. When the room setpoint conditions are satisfied, electric heat will be de-energized and the fan will continue to operate at its "fan only" setting when enabled, for continuous fan operation. If fan cycling is enabled, the fan will turn off after 30 seconds once room setpoint conditions are satisfied.

Control choices and added functionality

The control enclosure houses the major operating electrical controls including the MicroTech® III controller and I/O expansion module, control transformer, compressor relays and fan relay. Each component is accessible for service or replacement.



Three unique control choices are offered with the MicroTech III control system:

- Standalone operation using a MicroTech III controller and I/O expansion module

- MicroTech III controller and I/O expansion module with a LONWORKS® communication module
- MicroTech III controller and I/O expansion module with a BACnet® communication module

Each option features direct quick-connect wiring to all unit-controlled components for “clean” wiring inside the control box. Each control circuit board receives power from a 75VA transformer.

Table 3: Control options

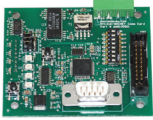
Control	Description	Application	Protocol
<p>MicroTech III</p>  <p>(Standalone) Unit Controller with I/O Expansion Module</p> 	<p>The MicroTech III controller is a standalone microprocessor-based control board conveniently located in the unit control enclosure for easy accessibility. The board is designed to provide thermostat control of a Water Source Heat Pump using a two-stage wall thermostat. The unit controller provides unit-wide control of the WSHP and control of the first refrigerant circuit.</p>	<p>Each unit controller is factory programmed, wired, and tested for complete control of single zone, standalone operation of your Daikin Water Source Heat Pump.</p>	<p>Unit-mounted or wall-mounted thermostat or room sensor</p>
	<p>The I/O Expansion Module is an extension of the Microtech III controller and provides control of the second refrigerant circuit. External LED status lights display fault conditions to provide easy troubleshooting and diagnosis of the second circuit.</p>	<p>Allows for:</p> <p>Control of second refrigeration circuit, secondary heating options and cooling/dehumidification options.</p>	
<p>LONWORKS</p>  <p>Communication Module</p>	<p>The MicroTech III control system accepts a plug-in LONWORKS communication module to provide network communications and added functionality to easily integrate with an existing BAS. The communication module can be factory- or field-installed and is tested with all logic required to monitor and control the unit.</p>	<p>LONTALK application protocol is designed for units that are integrated into a LONWORKS communication network for centralized scheduling and management of multiple heat pumps.</p>	<p>LONMARK 3.4 Certified</p>
<p>BACnet</p>  <p>Communication Module</p>	<p>The MicroTech III controller accepts a plug-in BACnet communication module to provide network communications and added functionality to easily integrate with an existing BAS. The communication module can be factory- or field-installed and is tested with all logic required to monitor and control the unit.</p>	<p>Designed to be linked with a centralized building automation system (BAS) through a BACnet communications network for centralized scheduling and management of multiple heat pumps.</p>	<p>BACnet MS/TP</p>

MicroTech® III controller

General use and information

All Microtech III controller inputs must be operated by dry contacts powered by the control board's power terminals. No solid state devices (Triacs) may be used to operate the Microtech III controller inputs. No outside power source may be used to operate the Microtech III controller inputs.

The MicroTech III control system includes two microprocessor-based control boards conveniently located in the unit control box for easy access through a removable access panel. The standalone controls are a hard wired interface and provides all the necessary field connections. The board can be wired for 24-volt AC output to the wall thermostat by using terminals R & C. Two sets of LED annunciators are located on the front of the unit chassis to allow quick check of the unit operating status.

Standard sequence of operation

Assumes cycle fan operation-not continuous fan operation:

- **Cooling mode** – On an initial call for stage 1 cooling, the fan will energize and the 45 second flow timer will start. When the compressor minimum off, and random startup timers are expired, the unit will start in stage 1 cooling. If additional capacity is needed, the unit will initiate stage 2 cooling. When the room setpoint conditions are satisfied, the stage 2 compressor will shut off first followed by the stage 1 compressor. If fan cycling is enabled, the fan will turn off once room setpoint conditions are satisfied.
- **Heating mode** – On an initial call for heating, the fan will energize, the pump request will energize, the 45 second flow timer will start. After the flow, compressor minimum off, and random startup timers are expired, the lead compressor will start at stage 1 heating settings; the reversing valve shall energize 5 seconds after the lead compressor turns on. If room setpoint conditions are not satisfied, the lag compressor will operate at stage 2 heating settings. When the room setpoint conditions are satisfied, the compressor will shut off. If fan cycling is enabled, the fan will turn off, once room setpoint conditions are satisfied.
- **Hot gas reheat with temperature control** – If the space temperature setpoint is satisfied, but the space humidity is above the humidity setpoint, the hot gas reheat mode is activated. The fan will energize, the pump request will energize, the 45 second flow timer will start, the compressor minimum off, and random startup timers expire, the hot gas reheat valve opens sending hot gas to the reheat coil, the stage 1 compressor energizes, and after 180 seconds the stage 2 compressor energizes. Return air is cooled and reheated to near space temperature. A call for cooling will close the hot gas reheat valve and the unit will resume normal cooling operation. If the space cooling and heating temperature setpoints are satisfied, but the humidity falls below the space humidity setpoint, the dehumidification mode is suspended.
- **Waterside economizer** – This mode requires the optional factory-installed waterside economizer. A hydronic economizer coil, 3-way water valve and temperature sensor are added to the unit. The purpose of this mode is to satisfy some or all of the cooling demand by using the loop water, which is often reduced to 50°F or less via the cooling tower to achieve sufficient cooling performance. When a call for 1st stage cooling is engaged, with the entering loop water below the economizer changeover temperature, the H8 output on the MicroTech III board is activated to open the motorized valve allowing water flow to the equipment. The compressor is locked out, the 3-way water valve opens to allow cool loop water to flow through the economizer coil. The fan starts after 30 seconds (unless it is already on thru activation of the G terminal by the thermostat fan switch "on"). On a further demand for cooling, stage 2; the 1st compressor will start in the cooling mode. On a further demand for cooling the second compressor will energize. The waterside economizer mode will not be activated if the entering water temperature is below 35°F and an alarm (fault) signal will be generated. When the room setpoint conditions are satisfied, the compressor will shut off, the 3-way valve will close and the fan will either shut off (fan switch "auto") or continue to run (fan switch "on"). The minimum off timer of 360 seconds starts. If the loop temperature increases above the changeover temperature, waterside economizer mode will be suspended and the unit will resume normal mechanical cooling mode with stage 1 of the thermostat now starting the compressor.

Available operating modes

- **Unoccupied mode** – A simple “grounded” signal between terminals U and C (no power source required), puts the unit into the unoccupied mode for night setback operation.

Secondary heating modes (field installed)

- **Supplementary electric heat control** – The supplemental electric heating option provides an additional stages of heating that can be used in conjunction with compressor heating, or exclusively if the compressor is not available for heating.
- **Boilerless electric heat mode** – When the entering water temperature is below setpoint, the compressors will not be allowed to operate. On an initial call for heating, the fan and electric heat will start. When the room setpoint conditions are satisfied, electric heat will be de-energized and the fan will continue to operate at its “fan only” setting when enabled, for continuous fan operation. If fan cycling is enabled, the fan will turn off after 30 seconds once room setpoint conditions are satisfied.

MicroTech III unit protections & LED fault status annunciation

- **Short cycle protection & random start** – After power cycle or deactivation of certain alarms, or when leaving the unoccupied mode, a new random compressor start-delay time between 300 and 360 seconds is generated. The random start timer prevents compressors in different units from starting simultaneously. Compressor minimum OFF 360 sec) and compressor minimum ON (180 sec) timers prevent compressor short cycling.
- **Interstaging timer** – A default value of 5 minutes between staging of compressors, this feature minimizes short cycling of compressors and improves comfort.
- **Motorized valve/pump restart** – The IV/PR (H8) terminals on the The MicroTech III unit controller are used to energize (open) a motorized valve or start a water pump to get water circulating prior to starting the compressor on call for heating or cooling. Lead compressor operation shall be delayed a minimum of 45 seconds, after the motorized valve/isolation valve output energizes to allow for supply water flow.
- **Brownout protection** – The MicroTech III unit controller measures the input voltage and will suspend compressor and fan operation if the voltage falls below 80% of the unit nameplate rated value. Two external LED status are generated and an output is available to a “fault” LED at the thermostat.

- **Emergency unit shutdown** – A simple grounded signal puts the unit into the shutdown mode. Remote shutdown is provided so that when properly connected to a water loop controller or remote switch, the emergency shutdown input can be used to shut down the water source heat pump. Compressor and fan operations are suspended, and an a unique two external LED status is generated.
- **Condensate overflow protection (cooling & dehumidification modes only)** – The MicroTech III unit controller incorporates a liquid sensor at the top of the drain pan. When the unit senses a high condensate water level for 60 consecutive seconds while in the cooling or dehumidification modes the unit enters the “Off Alarm” machine state. The dehumidification or cooling mode operation will immediately be de-energized as well as the pump output.
- **Thermostat fault reset (preferred method)** – A feature to reset some lockouts like high pressure and/or low temperature remote from the unit is available. When the cause of the fault condition has been fixed, repaired or resolved, the unit can be reset from the thermostat. To reset the fault, move the system switch on the thermostat from its current position (Heat/Auto/Cool) to the Off position and back to its original position two times within 30 seconds. The unit will now be reset. The intelligent reset counter and the 24 hour timer are cleared.

CAUTION

Some thermostats have internal timers greater than 30 seconds that delay their switching capabilities. Defeating their internal timers may be required to reset the fault using the thermostat.

Alternatively, thermostats have an optional “reset” feature, by activating the reset feature and adding a wire from terminal O to terminal TB1, pin 4, on the MicroTech III board.

- **Reset of automatic lockouts (alternate method)** - A feature to reset some lockouts like high pressure and/or low temperature at the unit is available. When the cause of the fault condition has been fixed, repaired or resolved, the unit can be reset at the unit. Apply a grounded signal to the tenant override input (screw terminal connection at TB1, pin 4) for a minimum of 10 seconds. The unit will now be reset. Alternatively, dropping power to the unit from the disconnect switch and re-applying power will reset the unit.

- **Intelligent alarm reset** – The Intelligent Reset feature helps to minimize nuisance trips of automatic lockouts caused by low-temperature faults. This feature clears faults the first two times they occur within a 24-hour period and triggers an automatic lockout on the 3rd fault. The fault remains active until the alarm is manually cleared. At the end of the 24 hour period, all counts for that specific intelligent reset alarm are cleared to zero only if the occurrence counter is presently less than the value of three. The 24-hour period and alarm counts are stored in memory that is cleared when power is cycled.
- **Selectable lead compressor** – The lead compressor selection provides a method to utilize circuit 2 if repairs are required on circuit 1. This is not intended for normal equipment operation. The jumper setting JP8 in the I/O expansion board is used to configure the “Lead Compressor” settings.

MicroTech III unit protections & LED fault status annunciation (continued)

- **Lead compressor fail replacement** – Upon detection of a lead compressor fault and the lag compressor is available, the selected lead compressor will be “failed replaced” by the lag compressor. Lead compressor will immediately be de-energized by ignoring the compressor minimum ON timer. Lag compressor will energize in place of the failed lead compressor, when the lag compressor minimum OFF timer has expired. Reversing valve for the lag compressor will be positioned, if necessary, 5 seconds after the lag compressor starts up.
- **Equipment protection control** – The MicroTech III controller receives separate input signals from the refrigerant high-pressure switch and the low suction line temperature sensor. In a high-pressure situation, compressor operation is suspended. In a low temperature situation, the unit goes into a defrost cycle where the unit is put into cooling operation for 60 seconds until the coaxial heat exchanger is free of ice. Each switch generates its own unique LED status.
- **Freeze fault protection option** – This factory-mounted option adds a leaving water temp, LWT, sensor to shut down compressor operation if the LWT gets too cold. It's a dual setting sensor, set for 35°F on boiler/tower and ground water applications (those with no anti-freeze) in the cooling & heating modes and geothermal applications in the cooling mode, or 13.5°F LWT on geothermal applications in the heating mode (those with anti-freeze). **Caution:** If you move the jumper to the lower (geothermal) setting, there is a risk of freeze-up if there is no anti-freeze in the loop.
- **Phase monitor option** – The factory-installed phase monitor helps to protect against phase loss, phase reversal and phase unbalance, and ideally suited for protection against reverse rotation of scroll and screw compressors.

Note: The settings of the hardware configuration jumpers are read when the controller is powered. Any changes to the jumper settings require cycling power to the controller or sending a controller a reboot command through the network communications.

Table 4: MicroTech III controller configuration jumper settings

Baseboard Description	Jumper(s)	Jumper Setting	Function
Normal / Test Mode	JP1	Open	Normal Operation
		Shorted	Service / Test Mode
Fan Operation	JP2	Open	Continuous Fan Operation (On), when not operating in the unoccupied mode.
		Shorted	Cycling Fan Operation (Auto)
Loop Fluid	JP3 (see warning)	Open	Water Loop Fluid - Water freeze protection (factory default setting)
		Shorted	Glycol Loop Fluid - Systems with anti-freeze protection
Freeze Fault Protection	JP4	Open	None
		Shorted	Freeze fault protection enabled
Room Sensor Setpoint Potentiometer Range	JP5	Open	Short Range: -5 to +5 °F (-2.78 to +2.78 °C)
		Shorted	Long Range: 55 to 95°F (12.78 to 35°C)
Thermostat / Room Sensor	JP6	Open	Thermostat Control
		Shorted	Room Sensor Control
Compressor Availability	JP7 & JP8	JP7 Open	Both Compressors Available (default)
		JP8 Open	
		JP7 Shorted	One Compressor Available
		JP8 Open	
		JP7 Open	No Compressors Available
		JP8 Shorted	

⚠ WARNING

Jumper JP3 is factory provided in the open position. Geothermal range units require freeze protection down to 15 degrees. Jumper JP3 must be field configured.

Table 5: MicroTech III controller status LED's

Description	Type*	Yellow	Green	Red
I/O Expansion Communication Fail	Fault	ON	Flash	Flash
Invalid Configuration	Fault	Flash	Flash	OFF
Low Voltage Brownout	Fault	OFF	Flash	OFF
Emergency Shutdown	Mode	OFF	Flash	OFF
Compressor #1 High Pressure (HP1)	Fault	OFF	OFF	Flash
Compressor #1 Low Pressure (LP1)	Fault	OFF	OFF	ON
Compressor #1 Suction Temp Sensor Fail	Fault	Flash	Flash	ON
Freeze Fault Detect (Freeze Fault Protection Only)	Fault	Flash	OFF	Flash
Compressor #1 Low Suction Temp (LT1)	Fault	Flash	OFF	OFF
Room Temp Sensor Fail (with Room Sensor Control Only)	Fault	Flash	Flash	ON
Leaving Water Temp Sensor Fail (Freeze Fault Protection Only)	Fault	Flash	Flash	ON
Condensate Overflow (Cooling & Dehumidification Modes Only)	Fault	ON	OFF	OFF
Serial EEPROM Corrupted	Fault	ON	ON	ON
Service Test Mode Enabled	Mode	Flash	Flash	Flash
Unoccupied Mode	Mode	ON	ON	OFF
Occupied, Bypass, Standby, or Tenant Override Modes	Mode	OFF	ON	OFF

Note: * The MicroTech III baseboard LED's mode / faults are listed in order of priority.

I/O expansion module

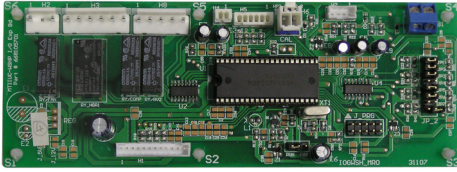

The I/O expansion module is factory-installed for control of the second refrigeration circuit.

The I/O Expansion Module has an independent LED annunciator to identify operational fault conditions for all the codes listed below.

Figure 3: I/O expansion module configuration jumper terminals

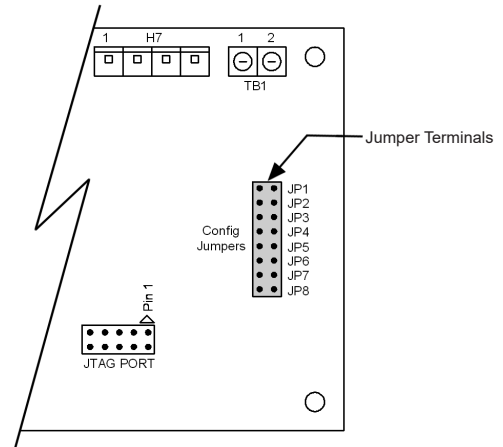

Note: The settings of the hardware configuration jumpers are read when the controller is powered. Any changes to the jumper settings require cycling power to the controller or sending a controller a reboot command through the network communications.

Table 6: I/O expansion module jumper settings

I/O Expansion Description	Jumper(s)	Jumper Setting		Model
Not Used	JP1	JP1	Open	–
Not Used	JP2	JP2	Open	–
Secondary Heating Options	JP3 & JP4	JP3	Open	None
		JP4	Open	
		JP3	Shorted	Supplemental Electric Heat
		JP4	Open	
		JP3	Open	Boilerless Electric Heat
		JP4	Shorted	
Cooling / Dehumidification Options	JP5 & JP6	JP5	Shorted	Without Hydronic Cooling
		JP6	Open	
		JP5	Open	Hydronic Cooling (Waterside Economizer)
		JP6	Shorted	
Not Used	JP7	JP7	Open	–
Lead Compressor Option	JP8	JP8	Open	Compressor #1 is Lead (factory default setting)
		JP8	Shorted	Compressor #2 is Lead

Table 7: I/O expansion module LED & fault outputs

Description	Type	Yellow	Green	Red
Baseboard Communication Fail	Fault	OFF	Flash	Flash
Compressor #2 High Pressure (HP2)	Fault	OFF	OFF	Flash
Compressor #2 Low Pressure (LP2)	Fault	OFF	OFF	ON
Compressor #2 Low Suction Temp (LT2) Sensor Fail	Fault	Flash	Flash	ON
Compressor #2 Low Suction Temp (LT2)	Fault	Flash	OFF	OFF
Entering Water Temp Sensor Fail (with Boilerless Electric Heat and Waterside Economizer)	Fault	ON	OFF	Flash
Low Entering Water Temperature (No Display with Boilerless Electric Heat)	Fault	OFF	ON	Flash
Fan is OFF	Mode	OFF	ON	OFF
Fan is ON	Mode	OFF	Flash	OFF

Note: Mode / Faults are listed in order of priority.

MicroTech® III controller with LONWORKS® or BACnet® communication module

The Large Horizontal Water Source Heat Pump can be equipped with a LONWORKS or BACnet communication module. The LONWORKS module is LONMARK 3.4 certified and designed to communicate over a LONWORKS communications network to a Building Automation System (BAS). The BACnet module is designed to communicate over a BACnet MS/TP communications network to a building automation system. Both controllers are micro-processor-based and can be factory or field-installed. The control modules are programmed and tested with all the logic required to monitor and control the unit. Optional wall sensors may be used with the communication modules to provide limited local control of the Horizontal Water Source Heat Pump. The MicroTech III controller monitors water and air temperatures and passes information to the communication module. The module communicates with the BAS, to provide network control of the Water Source Heat Pump.

MicroTech III LONWORKS communication module

The LONWORKS communication module is designed for units that are integrated into a LONWORKS communication network for centralized scheduling and management of multiple heat pumps.

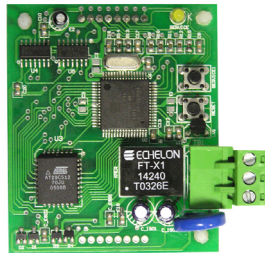

MicroTech III BACnet communication module

Designed to be linked with a centralized building automation system (BAS) through a BACnet communications network for centralized scheduling and management of multiple heat pumps.

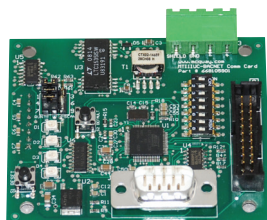

MicroTech III controller with communication modules features

The MicroTech III Controller with LONWORKS or BACnet Communication Module orchestrates the following unit operations:

- Enable heating and cooling to maintain space temperature setpoint based on a room sensor setting
- Enable fan and compressor operation
- Monitors all equipment protection controls
- Monitors room and discharge air temperatures
- Monitors leaving water temperature
- Relays status of all vital unit functions

An on-board status LED indicates the status of the MicroTech III LONWORKS or BACnet module.

The MicroTech III unit controller with communication module includes:

- Return Air Temperature sensor (RAT) (field-installed)
- Discharge Air Temperature sensor (DAT) (field-installed)
- Leaving Water Temperature sensor (LWT) (field-installed)

CAUTION

When an optional wall-mounted room temperature sensor is connected to the unit controller, the Return Air Temperature (RAT) sensor must not be installed. A wall-mounted room temperature sensor and the return air temperature sensor must not be connected simultaneously or the unit will not operate properly.

The communication modules provide network access to setpoints for operational control

Available wall sensors include:

- Room sensor
- Room sensor with LED status and tenant override button
- Temperature sensor with LED status, timed-override button; $\pm 5^{\circ}\text{F}$ setpoint adjustment
- Room sensor with LED status, timed-override button, 55° to 95°F setpoint adjustment
- Room sensor with digital display, timed override button, occupancy button; $\pm 5^{\circ}\text{F}$ setpoint adjustment or 55 to 95°F temperature setpoint and dehumidification control

Supply and return water hoses

Available as fire rated construction in 2 or 3 foot (610 mm or 914 mm) lengths. Fire rated hoses have a synthetic polymer core with an outer rated covering of stainless steel. Fittings are steel. Assembly is “fire rated” and tested according to UL 94 with a VO rating and ASTM 84. Each hose has MPT connections. Hoses have a swivel connection at one end and are available in 1¼” (32 mm) to match the FPT fittings on unit sizes 072 through 120. See catalog 1196 for the complete hose and hose kit offering.

Figure 4: Flexible, steel braided supply and return hoses



Hose specifications

Inner tube:

Fire retardant TRP (Thermoplastic Rubber) tested to UL-94 with V-O rating.

Outer braid:

Stainless steel wire (ANSI 302/304)

Temperature range:

40°F to 200°F

Condensate hose kit

Available as a long clear plastic hose with the necessary clamps and a MPT hose fitting for connection to the FPT field piping.

Figure 5: Condensate hose kit



Combination balancing and shutoff (ball) valves

Constructed of brass and rated at 400 psig (2758 kPa) maximum working pressure. Valves have a built-in adjustable memory stop to eliminate rebalancing. Valves have FPT connections on both ends for connection to the water hose and to the field piping.

Figure 6: Shut off ball valve

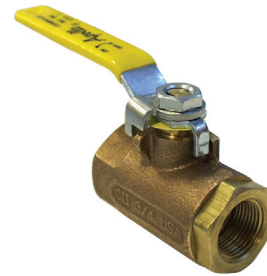

Motorized valve

Used in variable pumping type applications, the valve actuator is wired and typically piped in the return water line. The 2-way motorized water valve kit includes the valve body, actuator and wire harness. The 24VAC valve actuator must be wired directly to terminal block H8 on the MicroTech III controller. The valve will only energize on a call for heating or cooling. The 1-1/4" valve is rated for 300 psig (2068 kPa) and the 1-1/2" valve is rated for 150 psig (1034 kPa).

Figure 7: 2-way motorized valve

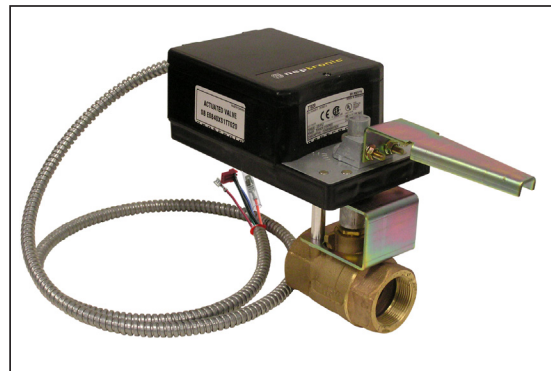

Typical horizontal installation

Unit location

It is important to leave enough space for service personnel to perform maintenance or repair. Locate the horizontal unit to allow for easy removal of the filter and access panels. Allow a minimum of 18" (46 cm) clearance on each side of the unit for service and maintenance access and do not install the unit above any piping. Always be sure to leave at least one side of the filter rack unobstructed so that the service personnel will be able to slide the filter out. Each unit is suspended from the ceiling by four 3/8" threaded rods fastened to the unit by a hanger bracket and rubber isolator. The design should place the unit directly below the structural members so that it is securely anchored.

Figure 8: Unit clearances

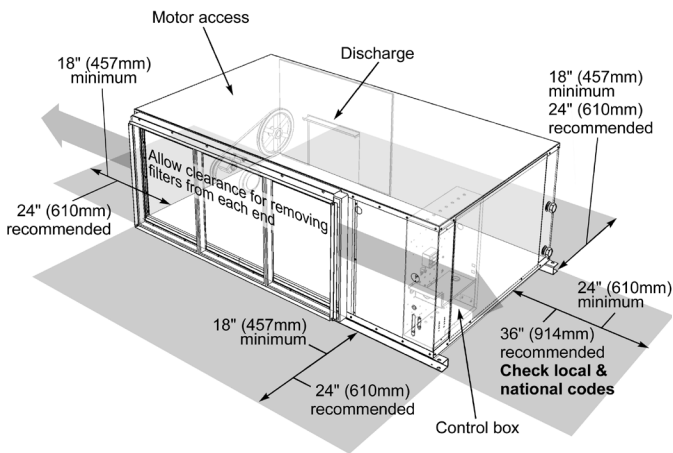

Avoid installing units directly above spaces where building occupants will reside (e.g. above office desks or classrooms) to reduce the requirement for noise attenuation. Do not place units above high traffic areas because service access may be limited during occupied hours. For example, units are typically installed above the hallway drop ceiling in Schools and the supply and return air is routed directly into classrooms. Local code may require fire dampers to be used with this application.

Piping

The WSHP unit is typically connected to the supply/return piping using a "reverse return" piping system which includes a flow control device so that flow requirements are met for each zone. A short, high pressure "flexible hose" is used to connect the unit to the building's hard piping and acts as a sound attenuator for both the unit operating noise and hydraulic pumping noise. One end of the hose has a swivel fitting to facilitate removal of the unit for replacement or service. Include supply and return shutoff valves in the design to allow removal of a unit without the need to shut down the entire heat pump system. The return valve may be used for balancing and will typically have a "memory stop" so that it can be reopened to the proper position for the flow required.

Figure 9: Typical ceiling installation

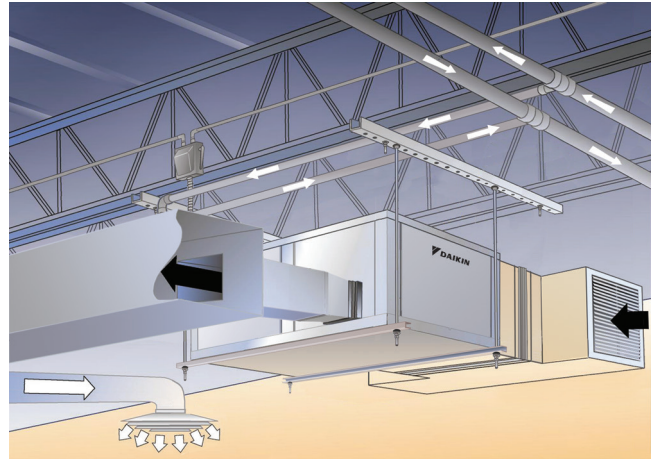

Fixed flow devices are commercially available and can be installed to eliminate the need for memory stop shut off valves. Include Pressure / Temperature ports to allow the service technician to measure water flow and unit operation.

Condensate drain piping

Condensate piping can be made of steel, copper or PVC pipe. In most cases, PVC pipe eliminates the need to wrap insulation around the pipe to prevent sweating. A threaded, factory supplied condensate fitting allows the connection of PVC, flexible vinyl hose or steel braided hose.

The condensate piping must be trapped at the unit and pitched away from the unit not less than 1/4" per foot. A vent is required after the trap so that the condensate will drain away from the unit. The vent can also act as a clean out if the trap becomes clogged. To avoid having waste gases entering the building, the condensate drain should not be directly piped to a drain/waste/vent stack. See local codes for the correct application of condensate piping to drains.

Figure 10: Typical condensate piping

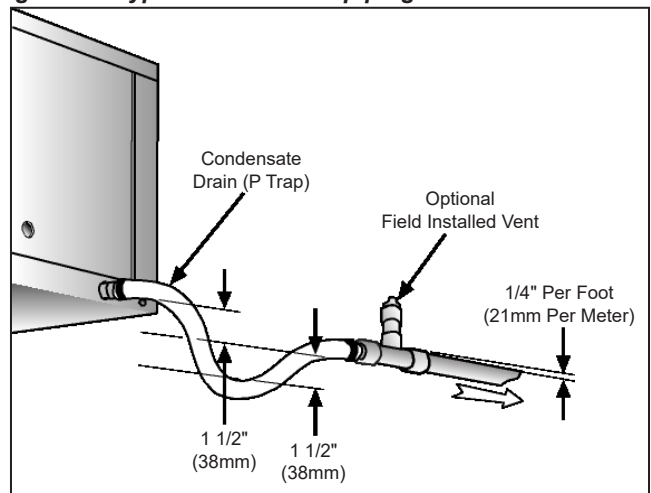

Ductwork and attenuation

Ductwork is normally applied to ceiling-mounted heat pumps on the discharge side of the unit. A discharge collar is provided on all horizontal unit models for fastening the ductwork. Use a flexible connector between the discharge collar and the duct transformation to help reduce vibration transmission from the cabinet and to simplify disconnection of the unit from the ceiling ductwork. If return ductwork is to be used, attach a flexible connector to the filter rack collar to help reduce vibration transmission and removal of the unit. Return plenum ducting should be at least 12 inches away from the coil so that the coil is evenly loaded with return air.

As a general recommendation, duct interiors should have an acoustic / thermal lining at least 1/2 inch thick over the entire duct run. For better sound attenuation, line the last five diameters of duct before each register with a one-inch thick sound blanket. Elbows, tees and dampers can create turbulence or distortion in the

airflow. Place a straight length of duct, 5 to 10 times the duct width, before the next fitting to smooth out airflow. Diffusers that are located in the bottom of a trunk duct can also produce noise. For this same reason, volume control dampers should be located several duct widths upstream from an air outlet.

For Hotel, Motel, Dormitory or Nursing Home applications that use a single duct discharge, a velocity of 500 to 600 fpm is suggested. These applications typically have static pressures as low as 0.05 inches of water and duct lengths approximately six feet in length. The discharge duct must be fully lined and have a square elbow without turning vanes. Return air for these applications should enter through a “low” sidewall filter grille and route up the stud space to a ceiling plenum. For horizontal heat pumps mounted from the ceiling, an insulated return plenum is sometimes placed at the return air opening to further attenuate line-of-sight sound transmission through return openings.

Figure 11: Suggested supply ducting per ASHRAE and SMACNA publications

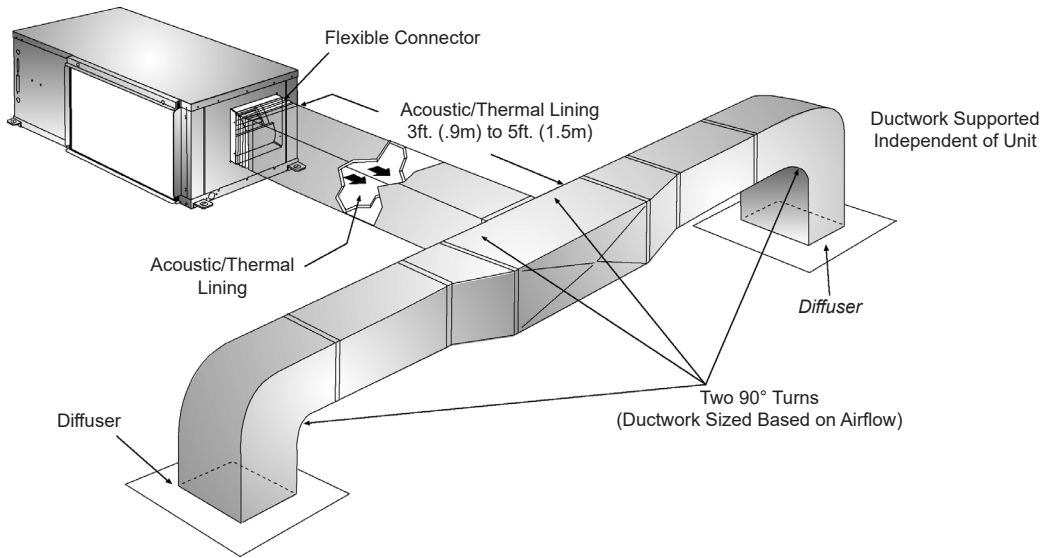
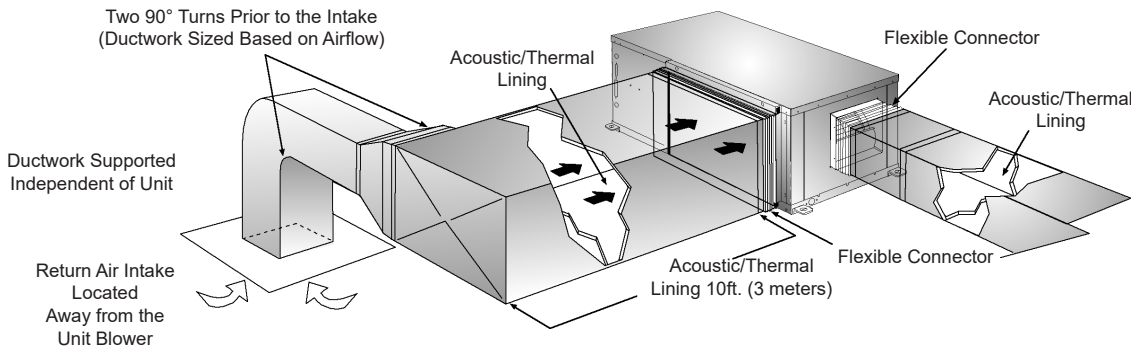
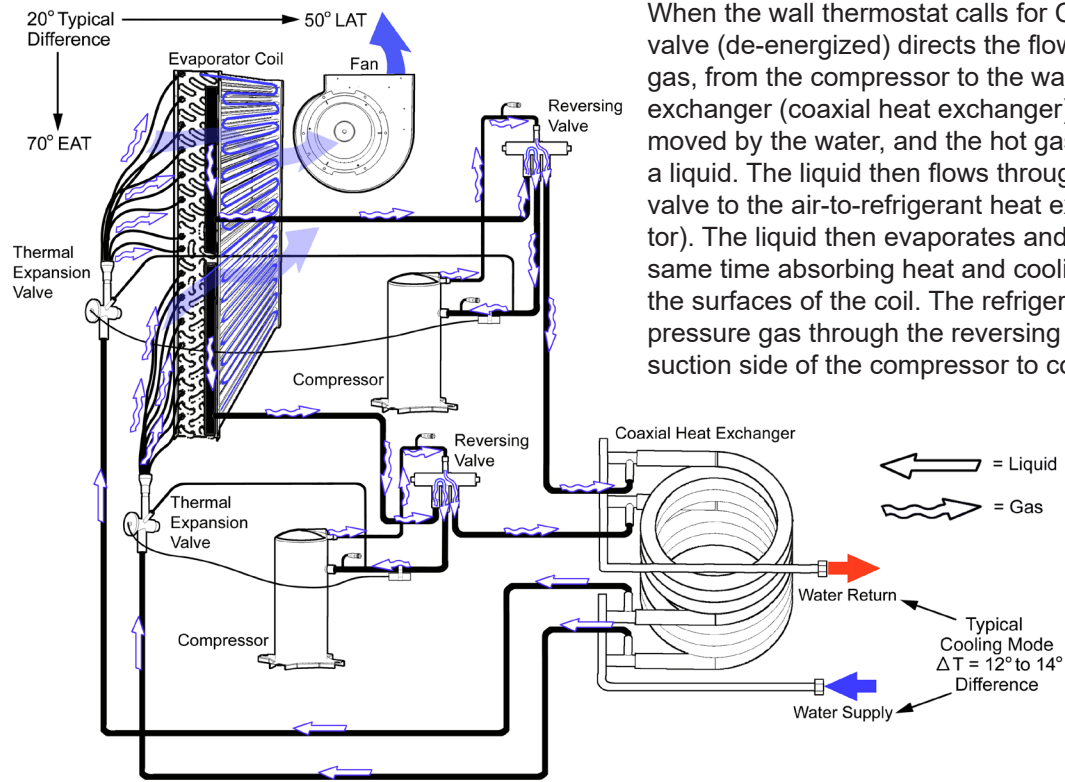

Figure 12: Suggested return ducting per ASHRAE and SMACNA publications



Typical cooling and heating refrigeration cycles – dual compressors

Figure 13: Cooling refrigeration cycle



When the wall thermostat calls for COOLING, the reversing valve (de-energized) directs the flow of the refrigerant, a hot gas, from the compressor to the water-to-refrigerant heat exchanger (coaxial heat exchanger). There, the heat is removed by the water, and the hot gas condenses to become a liquid. The liquid then flows through a thermal expansion valve to the air-to-refrigerant heat exchanger coil (evaporator). The liquid then evaporates and becomes a gas, at the same time absorbing heat and cooling the air passing over the surfaces of the coil. The refrigerant then flows as a low pressure gas through the reversing valve and back to the suction side of the compressor to complete the cycle.

Figure 14: Heating refrigeration cycle

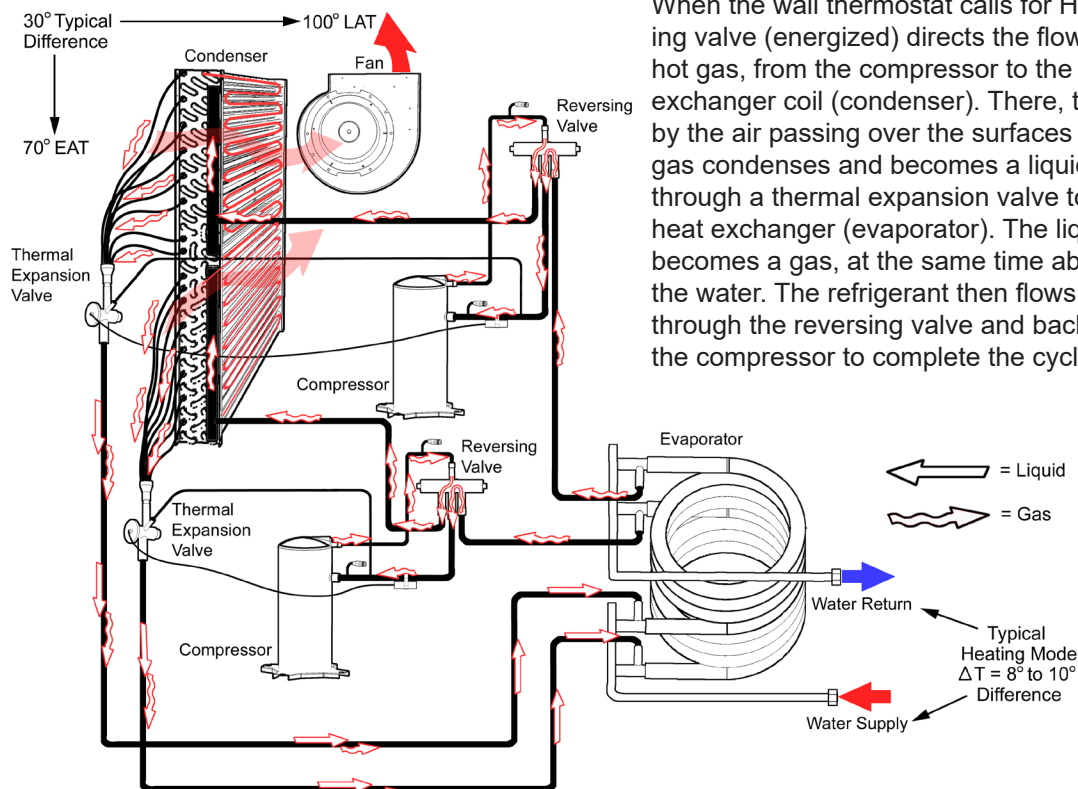

When the wall thermostat calls for HEATING, the reversing valve (energized) directs the flow of the refrigerant, a hot gas, from the compressor to the air-to-refrigerant heat exchanger coil (condenser). There, the heat is removed by the air passing over the surfaces of the coil and the hot gas condenses and becomes a liquid. The liquid then flows through a thermal expansion valve to the water-to-refrigerant heat exchanger (evaporator). The liquid then evaporates and becomes a gas, at the same time absorbing heat and cooling the water. The refrigerant then flows as a low pressure gas through the reversing valve and back to the suction side of the compressor to complete the cycle.

Note: Typical temperature readings are at full load conditions at ISO-13256 for boiler-tower applications.

Typical hot gas reheat refrigeration cycle – dual compressors

When the DEHUMID setting is not satisfied and COOLING has been satisfied the reversing valve remains (de-energized) but the hot gas reheat (HGRH) valve is (energized). This directs the flow of the refrigerant, a hot gas, from the compressor through the hot gas reheat (HGRH) coil thus heat is removed from the refrigerant gas to reheating the cooled air from the evaporator coil. Then the refrigerant flows to the water-to-

refrigerant heat exchanger (coaxial heat exchanger). There, the heat is removed by the water, and the hot gas condenses to become a liquid. The liquid then flows through a thermal expansion valve to the air-to-refrigerant heat exchanger coil (evaporator). The liquid then evaporates and becomes a gas, at the same time absorbing heat and cooling the air passing over the surfaces of the coil. The refrigerant then flows as a low pressure gas through the reversing valve and back to the suction side of the compressor to complete the cycle.

Figure 15: Hot gas reheat refrigeration cycle

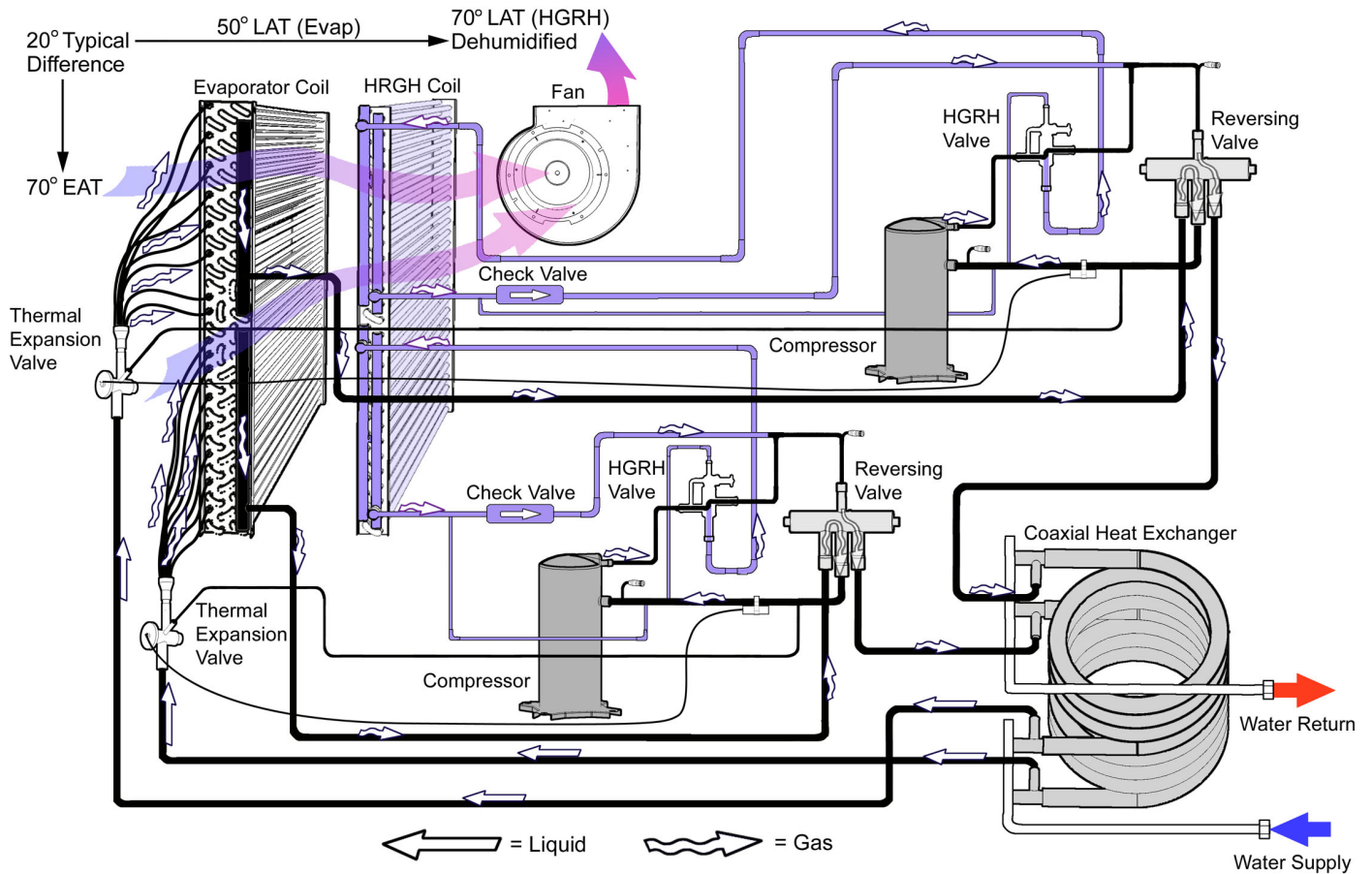

Systems

Water source heat pump systems are one of the most efficient, environmentally friendly systems available for heating and cooling buildings. High-efficiency, self contained units (sizes 7,000 btuh to 290,000 btuh) can be placed in virtually any location within a building. Each unit responds only to the heating or cooling load of the individual zone it serves. This permits an excellent comfort level for occupants, better control of energy use for building owners and lower seasonal operating costs. The Air-Conditioning Refrigeration Institute (ARI) and the International Standards Organization (ISO) publish standards so that water source heat pumps are rated for specific applications. The ARI/ISO loop options shown in this catalog are typical water source heat pump loop choices available in today's market. These systems offer benefits ranging from low cost installation to the highest energy efficiency available in the market today.

Boiler / tower applications: AHRI 320 / ISO 13256-1

A "Boiler/Tower" application uses a simple two-pipe water circulating system that adds heat, removes heat or transfers rejected heat to other units throughout the building. The water temperature for heating is generally maintained between 65°F – 70°F and is usually provided by a natural gas or electric boiler located in a mechanical room. The condensing water temperature, during cooling months, is maintained between 85°F and 95°F and requires the use of a cooling tower to dissipate waste heat. Cooling towers can be located on the roof, or inside or adjacent to the building. This application can be the lowest cost of the loop options available.

Note: ASHRAE 90.1 standards require that circulating pumps over 10 HP will require use of "variable frequency drive" equipment and pipe insulation to be used whenever water temperatures are below 60 degrees and above 105 degrees. See ASHRAE 90.1 Standards for details.

Figure 16: Boiler/tower application

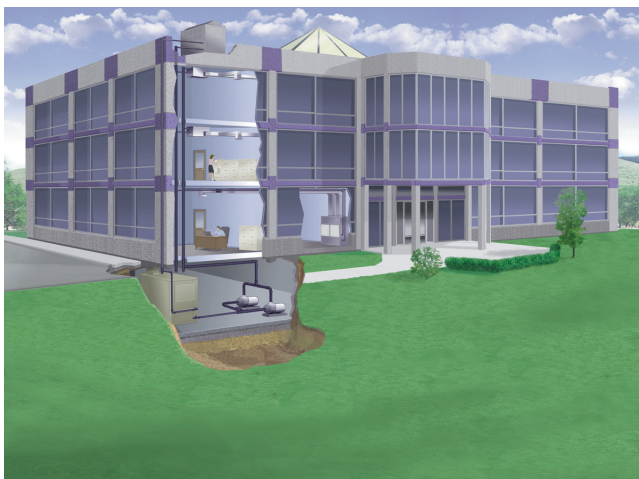

Open loop well water applications: AHRI 325 / ISO 13256-1

"Open Loop" well water systems use ground water to remove or add heat to the interior water loop. The key benefit of an open loop system is the constant water temperature, usually 50°F to 60°F, which provides efficient operation at a low first cost. Most commercial designers incorporate a heat exchanger to isolate the building loop from the well water. Using heat exchangers can reduce maintenance issues while still allowing the transfer of heat from unit to unit as with the "Boiler/Tower System". A successful design provides an ample amount of groundwater (approximately 2 GPM per ton) and adequate provisions for discharging water back to the aquifer or surface. Open Loop applications are commonly used in coastal areas where soil characteristics allow reinjection wells to return the water back to the aquifer. Note that some states have requirements on the depths of return water reinjection wells, and such wells must be approved by the United States Environmental Protection Agency. Also, bad water quality can increase problems with heat exchanger scaling. Suspended solids can erode the heat exchanger. Strainers can be used to contain suspended solids.

Figure 17: Open loop well application

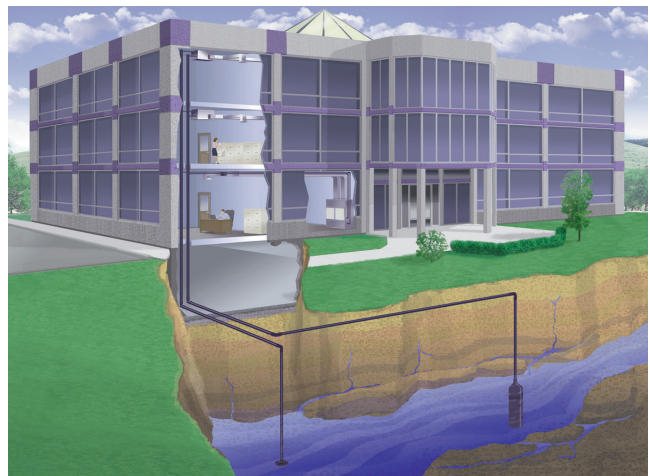

**Closed loop geothermal applications:
AHRI 330/ISO 13256-1**

“Vertical Closed Loop” applications are installed by drilling vertical bore holes into the earth and inserting a plastic polyethylene supply/return pipe into the holes. The vertical wells are connected in parallel reverse return fashion to allow the water from the building to circulate evenly throughout the bore field. The circulating fluid dissipates heat to the ground in a similar manner as a “tower” and adds heat back to the loop like a boiler. If properly designed, the loop field can maintain the loop temperatures necessary to condition the building without the use of a boiler or a tower. Loop temperatures usually range from 37°F to 95°F in Northern climates. Southern applications can see temperatures ranging from 40°F to 100°F. The number of bore holes and their depth should be determined by using commercial software that is specifically designed for vertical geothermal applications. Typical bore depths of a vertical loop range from 150 to 400 feet and generally require about 250 feet of surface area per ton of cooling.

Figure 18: Vertical loop application

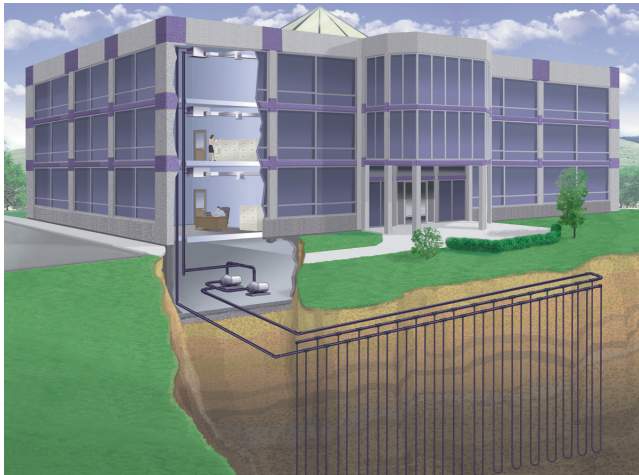

A closed loop “Horizontal” geothermal application is similar to a vertical loop application with the exception that the loops are installed in trenches approximately 5 feet below the ground surface. The piping may be installed using a “four-pipe” or “six-pipe” design and could require 1,500 to 2,000 square feet of surface area per ton of cooling. Loop temperatures for a commercial application can range from 35°F to 95°F in Northern climates. Southern climates can see temperatures ranging from 40°F to 100°F. Horizontal loops are generally not applied in urban areas because land use and costs can be prohibitive. New advances in installation procedures have improved the assembly time of horizontal loops while keeping the first cost lower than a vertical loop.

Figure 19: Horizontal loop application

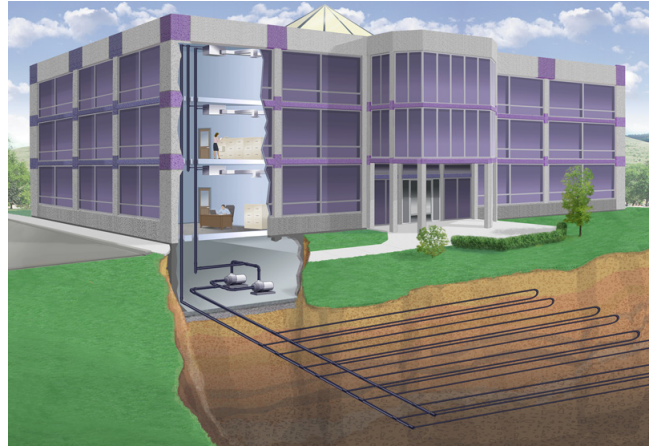

A “Surface Water” or “Lake” closed loop system is a geothermal loop that is directly installed in a lake or body of water that is near the building. In many cases, the body of water is constructed on the building site to meet drainage or aesthetic requirements. Surface loops use bundled polyethylene coils that are connected in the same manner as a vertical or horizontal loop using a parallel reverse return design. The size and the depth of the lake is critical. Commercial design services should be used to certify that a given body of water is sufficient to withstand the building loads. Loop temperatures usually range from 35°F to 90°F and prove to be the best cooling performer and lowest cost loop option of the three geothermal loops. Some applications may not be good candidates due to public access or debris problems from flooding.

Figure 20: Surface water loop application



Size 072 (2400 SCFM)

EWT (°F)	GPM	WPD		EAT (°F)	Cooling					Heating									
		PSI	FT of W.C.		Total (Btu/hr)	Sensible (Btu/hr)	Power Input (kW)	THR (Btu/hr)	EER	Total (Btu/hr)	Power Input (kW)	THA (Btu/hr)	LAT (°F)	COP					
20	12.0	1.7	3.9	65/55	Tint = Operation Not Recommended (See page 29 for Capacity Table Legend)					46200	4.445	31000	83	3.04					
		1.7	3.9	70/59						45900	4.680	29900	88	2.87					
		1.7	3.9	75/63						45500	4.916	28700	92	2.71					
		1.7	3.9	80/67						45100	5.151	27500	97	2.56					
		1.7	3.9	85/71															
	18.0	3.6	8.3	65/55											51400	4.546	35900	85	3.31
		3.6	8.3	70/59											51000	4.781	34700	90	3.12
		3.6	8.3	75/63											50600	5.017	33500	94	2.95
		3.6	8.3	80/67											50300	5.252	32400	99	2.80
	24.0	6.3	14.3	65/55											56600	4.646	40700	87	3.57
		6.3	14.3	70/59											56200	4.882	39500	92	3.37
		6.3	14.3	75/63											55800	5.117	38300	96	3.19
6.3		14.3	80/67						55400	5.353	37100	101	3.03						
6.3		14.3	85/71																
30	12.0	1.6	3.7	65/55						52900	4.683	36900	85	3.31					
		1.6	3.7	70/59	64700	47500	3.471	76500	18.6	52500	4.919	35700	90	3.13					
		1.6	3.7	75/63	68700	48800	3.513	80700	19.6	52100	5.154	34500	95	2.96					
		1.6	3.7	80/67	72600	50200	3.555	84700	20.4	51800	5.390	33400	100	2.81					
		1.6	3.7	85/71	76600	51500	3.598	88900	21.3										
	18.0	3.5	8.0	65/55	61300	46400	3.359	72800	18.2	58100	4.784	41800	87	3.56					
		3.5	8.0	70/59	65300	47700	3.401	76900	19.2	57700	5.020	40600	92	3.37					
		3.5	8.0	75/63	69300	49100	3.443	81100	20.1	57300	5.255	39400	97	3.19					
		3.5	8.0	80/67	73200	50400	3.485	85100	21.0	56900	5.491	38200	102	3.03					
	24.0	6.1	13.9	65/55	61900	46600	3.289	73100	18.8	63200	4.885	46500	89	3.79					
		6.1	13.9	70/59	65900	48000	3.331	77300	19.8	62900	5.121	45400	94	3.60					
		6.1	13.9	75/63	69900	49300	3.373	81400	20.7	62500	5.356	44200	99	3.42					
6.1		13.9	80/67	73800	50600	3.416	85500	21.6	62100	5.592	43000	104	3.25						
6.1		13.9	85/71	77800	52000	3.458	89600	22.5											
40	12.0	1.6	3.6	65/55	64900	49000	3.664	77400	17.7	59600	4.922	42800	88	3.55					
		1.6	3.6	70/59	68900	50300	3.706	81500	18.6	59200	5.158	41600	93	3.36					
		1.6	3.6	75/63	72800	51600	3.749	85600	19.4	58800	5.393	40400	98	3.19					
		1.6	3.6	80/67	76800	53000	3.791	89700	20.3	58400	5.629	39200	102	3.04					
		1.6	3.6	85/71	80800	54300	3.833	93900	21.1										
	18.0	3.4	7.8	65/55	65500	49200	3.594	77800	18.2	64700	5.023	47600	90	3.77					
		3.4	7.8	70/59	69500	50500	3.636	81900	19.1	64400	5.258	46500	95	3.59					
		3.4	7.8	75/63	73400	51900	3.679	86000	20.0	64000	5.494	45200	100	3.41					
		3.4	7.8	80/67	77400	53200	3.721	90100	20.8	63600	5.729	44000	104	3.25					
	24.0	5.9	13.5	65/55	66100	49400	3.524	78100	18.8	69900	5.124	52400	92	3.99					
		5.9	13.5	70/59	70100	50800	3.567	82300	19.7	69500	5.359	51200	97	3.80					
		5.9	13.5	75/63	74000	52100	3.609	86300	20.5	69100	5.595	50000	102	3.62					
5.9		13.5	80/67	78000	53400	3.651	90500	21.4	68800	5.830	48900	106	3.46						
5.9		13.5	85/71	82000	54800	3.694	94600	22.2											
50	12.0	1.5	3.5	65/55	66900	50700	3.892	80200	17.2	66200	5.161	48600	90	3.76					
		1.5	3.5	70/59	70900	52000	3.934	84300	18.0	65900	5.396	47500	95	3.58					
		1.5	3.5	75/63	74900	53400	3.977	88500	18.8	65500	5.632	46300	100	3.41					
		1.5	3.5	80/67	78800	54700	4.019	92500	19.6	65100	5.867	45100	105	3.25					
		1.5	3.5	85/71	82800	56100	4.061	96700	20.4										
	18.0	3.3	7.6	65/55	67500	50900	3.822	80500	17.7	71400	5.261	53400	92	3.97					
		3.3	7.6	70/59	71500	52300	3.865	84700	18.5	71000	5.497	52200	97	3.78					
		3.3	7.6	75/63	75500	53600	3.907	88800	19.3	70600	5.732	51000	102	3.61					
		3.3	7.6	80/67	79400	55000	3.949	92900	20.1	70300	5.968	49900	107	3.45					
	24.0	5.7	13.1	65/55	68100	51200	3.752	80900	18.2	76600	5.362	58300	94	4.18					
		5.7	13.1	70/59	72100	52500	3.795	85100	19.0	76200	5.598	57100	99	3.99					
		5.7	13.1	75/63	76100	53900	3.837	89200	19.8	75800	5.833	55900	104	3.81					
5.7		13.1	80/67	80000	55200	3.879	93200	20.6	75400	6.069	54700	109	3.64						
5.7		13.1	85/71	84000	56500	3.922	97400	21.4											
60	12.0	1.5	3.4	65/55	67400	51700	4.208	81800	16.0	72900	5.399	54500	93	3.95					
		1.5	3.4	70/59	71400	53000	4.250	85900	16.8	72500	5.635	53300	98	3.77					
		1.5	3.4	75/63	75300	54300	4.293	90000	17.5	72100	5.870	52100	103	3.60					
		1.5	3.4	80/67	79300	55700	4.335	94100	18.3	71800	6.106	51000	108	3.44					
		1.5	3.4	85/71	83300	57000	4.377	98200	19.0										
	18.0	3.3	7.4	65/55	68000	51900	4.138	82100	16.4	78100	5.500	59300	95	4.16					
		3.3	7.4	70/59	72000	53200	4.180	86300	17.2	77700	5.735	58100	100	3.97					
		3.3	7.4	75/63	75900	54600	4.223	90300	18.0	77300	5.971	56900	105	3.79					
		3.3	7.4	80/67	79900	55900	4.265	94500	18.7	76900	6.207	55700	110	3.63					
	24.0	5.6	12.8	65/55	68600	52100	4.068	82500	16.9	83200	5.601	64100	97	4.35					
		5.6	12.8	70/59	72600	53500	4.111	86600	17.7	82900	5.836	63000	102	4.16					
		5.6	12.8	75/63	76500	54800	4.153	90700	18.4	82500	6.072	61800	107	3.98					
5.6		12.8	80/67	80500	56100	4.195	94800	19.2	82100	6.307	60600	111	3.81						
5.6		12.8	85/71	84500	57500	4.238	99000	19.9											

Size 072 (2400 SCFM) (Continued)

EWT (°F)	GPM	WPD		EAT (°F)	Cooling					Heating					
		PSI	FT of W.C.		Total (Btu/hr)	Sensible (Btu/hr)	Power Input (kW)	THR (Btu/hr)	EER	Total (Btu/hr)	Power Input (kW)	THA (Btu/hr)	LAT (°F)	COP	
70	12.0	1.5	3.4	65/55	66500	51800	4.707	82600	14.1	79600	5.638	60400	96	4.13	
		1.5	3.4	70/59	70500	53100	4.749	86700	14.8	79200	5.873	59200	100	3.95	
		1.5	3.4	75/63	74500	54400	4.792	90900	15.5	78800	6.109	57900	105	3.78	
		1.5	3.4	80/67	78500	55800	4.834	95000	16.2	78400	6.344	56700	110	3.62	
	18.0	1.5	3.4	85/71	82400	57100	4.876	99000	16.9						
		3.2	7.3	65/55	67100	52000	4.637	82900	14.5	84700	5.739	65100	97	4.32	
		3.2	7.3	70/59	71100	53300	4.680	87100	15.2	84400	5.974	64000	102	4.14	
		3.2	7.3	75/63	75100	54700	4.722	91200	15.9	84000	6.210	62800	107	3.96	
	24.0	3.2	7.3	80/67	79100	56000	4.764	95400	16.6	83600	6.445	61600	112	3.80	
		3.2	7.3	85/71	83000	57400	4.807	99400	17.3						
		5.5	12.5	65/55	67700	52200	4.567	83300	14.8	89900	5.839	70000	99	4.51	
		5.5	12.5	70/59	71700	53600	4.610	87400	15.6	89500	6.075	68800	104	4.31	
80	12.0	5.5	12.5	75/63	75700	54900	4.652	91600	16.3	89100	6.310	67600	109	4.13	
		5.5	12.5	80/67	79600	56300	4.694	95600	17.0	88800	6.546	66500	114	3.97	
		5.5	12.5	85/71	83600	57600	4.737	99800	17.6						
		1.4	3.3	65/55	64500	51000	5.485	83200	11.8	86200	5.876	66100	98	4.30	
90	12.0	1.4	3.3	70/59	68500	52300	5.527	87400	12.4	85900	6.112	65000	103	4.12	
		1.4	3.3	75/63	72400	53700	5.570	91400	13.0	85500	6.347	63800	108	3.94	
		1.4	3.3	80/67	76400	55000	5.612	95600	13.6	85100	6.583	62600	113	3.79	
		1.4	3.3	85/71	80400	56300	5.654	99700	14.2						
	18.0	3.1	7.1	65/55	65100	51200	5.415	83600	12.0	91400	5.977	71000	100	4.48	
		3.1	7.1	70/59	69100	52600	5.457	87700	12.7	91000	6.213	69800	105	4.29	
		3.1	7.1	75/63	73000	53900	5.500	91800	13.3	90600	6.448	68600	110	4.11	
		3.1	7.1	80/67	77000	55200	5.542	95900	13.9	90300	6.684	67500	115	3.96	
	24.0	3.1	7.1	85/71	81000	56600	5.584	100100	14.5						
		5.4	12.3	65/55	65700	51500	5.345	83900	12.3	96600	6.078	75900	102	4.65	
		5.4	12.3	70/59	69700	52800	5.388	88100	12.9	96200	6.313	74700	107	4.46	
		5.4	12.3	75/63	73600	54100	5.430	92100	13.6	95800	6.549	73400	112	4.28	
100	12.0	5.4	12.3	80/67	77600	55500	5.472	96300	14.2	95400	6.785	72200	117	4.12	
		5.4	12.3	85/71	81600	56800	5.514	100400	14.8						
		1.4	3.3	65/55	61200	49400	6.637	83900	9.2	92900	6.115	72000	101	4.45	
		1.4	3.3	70/59	65200	50700	6.679	88000	9.8	92500	6.350	70800	105	4.27	
	18.0	1.4	3.3	75/63	69200	52000	6.721	92100	10.3	92100	6.586	69600	110	4.09	
		1.4	3.3	80/67	73100	53400	6.764	96200	10.8	91800	6.822	68500	115	3.94	
		1.4	3.3	85/71	77100	54700	6.806	100300	11.3						
		3.1	7.0	65/55	61800	49600	6.567	84200	9.4	98100	6.216	76900	103	4.62	
	24.0	3.1	7.0	70/59	65800	51000	6.609	88400	10.0	97700	6.451	75700	107	4.43	
		3.1	7.0	75/63	69800	52300	6.651	92500	10.5	97300	6.687	74500	112	4.26	
		3.1	7.0	80/67	73700	53600	6.694	96500	11.0	96900	6.922	73300	117	4.10	
		3.1	7.0	85/71	77700	55000	6.736	100700	11.5						
110	12.0	5.3	12.1	65/55	62400	49900	6.497	84600	9.6	103200	6.317	81600	105	4.78	
		5.3	12.1	70/59	66400	51200	6.539	88700	10.2	102900	6.552	80500	109	4.60	
		5.3	12.1	75/63	70300	52500	6.582	92800	10.7	102500	6.788	79300	114	4.42	
		5.3	12.1	80/67	74300	53900	6.624	96900	11.2	102100	7.023	78100	119	4.26	
	18.0	5.3	12.1	85/71	78300	55200	6.666	101100	11.7						
		1.4	3.2	65/55	56700	47300	8.258	84900	6.9						
		1.4	3.2	70/59	60700	48600	8.300	89000	7.3						
		1.4	3.2	75/63	64700	49900	8.342	93200	7.8						
	24.0	1.4	3.2	80/67	68600	51300	8.385	97200	8.2						
		1.4	3.2	85/71	72600	52600	8.427	101400	8.6						
		3.0	6.9	65/55	57300	47500	8.188	85200	7.0						
		3.0	6.9	70/59	61300	48800	8.230	89400	7.4						
110	18.0	3.0	6.9	75/63	65300	50200	8.273	93500	7.9						
		3.0	6.9	80/67	69200	51500	8.315	97600	8.3						
		3.0	6.9	85/71	73200	52900	8.357	101700	8.8						
		5.2	11.9	65/55	57900	47800	8.118	85600	7.1						
	24.0	5.2	11.9	70/59	61900	49100	8.160	89800	7.6						
		5.2	11.9	75/63	65900	50400	8.203	93900	8.0						
		5.2	11.9	80/67	69800	51800	8.245	97900	8.5						
		5.2	11.9	85/71	73800	53100	8.287	102100	8.9						
	110	12.0	1.4	3.2	65/55	51100	45600	10.444	86700	4.9					
			1.4	3.2	70/59	55100	46900	10.486	90900	5.3					
			1.4	3.2	75/63	59100	48200	10.528	95000	5.6					
			1.4	3.2	80/67	63000	49600	10.571	99100	6.0					
18.0		1.4	3.2	85/71	67000	50900	10.613	103200	6.3						
		3.0	6.8	65/55	51700	45800	10.374	87100	5.0						
		3.0	6.8	70/59	55700	47100	10.416	91200	5.3						
		3.0	6.8	75/63	59700	48500	10.459	95400	5.7						
24.0		3.0	6.8	80/67	63600	49800	10.501	99400	6.1						
		3.0	6.8	85/71	67600	51100	10.543	103600	6.4						
		5.2	11.8	65/55	52300	46000	10.304	87500	5.1						
		5.2	11.8	70/59	56300	47400	10.347	91600	5.4						
110	24.0	5.2	11.8	75/63	60200	48700	10.389	95700	5.8						
		5.2	11.8	80/67	64200	50000	10.431	99800	6.2						
		5.2	11.8	85/71	68200	51400	10.473	103900	6.5						

Tint = Operation Not Recommended

Notes:

1. Operation below 40°F EWT is based upon a 15% methanol antifreeze solution.
2. Performance stated is at the rated power supply; performance may vary as the power supply varies from the rated.
3. See performance correction tables for operating conditions other than those listed.
4. Interpolation is permissible; extrapolation is not.
5. For performance data outside the EAT listed, refer to the Daikin SelectTools selection program
6. Table does not reflect fan or pump power corrections for AHR/ISO conditions.
7. Data is base on unit at full load operation..

Size 096 (3000 SCFM)

EWT (°F)	GPM	WPD		EAT (°F)	Cooling					Heating				
		PSI	FT of W.C.		Total (Btu/hr)	Sensible (Btu/hr)	Power Input (kW)	THR (Btu/hr)	EER	Total (Btu/hr)	Power Input (kW)	THA (Btu/hr)	LAT (°F)	COP
20	16.0	2.9	6.6	65/55	Tint = Operation Not Recommended (See page 29 for Capacity Table Legend)					49900	5.407	31400	80	2.70
		2.9	6.6	70/59						49200	5.748	29600	85	2.51
		2.9	6.6	75/63						48400	6.089	27600	90	2.33
		2.9	6.6	80/67						47700	6.431	25800	95	2.17
		2.9	6.6	85/71										
	24.0	6.3	14.3	65/55						59100	5.586	40000	83	3.10
		6.3	14.3	70/59						58300	5.927	38100	88	2.88
		6.3	14.3	75/63						57600	6.268	36200	93	2.69
		6.3	14.3	80/67						56900	6.610	34300	97	2.52
		6.3	14.3	85/71										
	32.0	10.8	24.7	65/55						68200	5.765	48500	86	3.46
		10.8	24.7	70/59						67500	6.106	46700	91	3.24
		10.8	24.7	75/63						66800	6.448	44800	96	3.03
		10.8	24.7	80/67						66100	6.789	42900	100	2.85
		10.8	24.7	85/71										
	30	16.0	2.8	6.4						65/55	82600	59900	3.404	94200
2.8			6.4	70/59	88000	62100	3.462	99800	25.4	57000	5.903	36900	87	2.83
2.8			6.4	75/63	93500	64300	3.521	105500	26.6	56300	6.244	35000	92	2.64
2.8			6.4	80/67	99000	66500	3.580	111200	27.7	55600	6.585	33100	97	2.47
2.8			6.4	85/71										
24.0		6.1	13.9	65/55	78200	58100	3.221	89200	24.3	66900	5.741	47300	86	3.41
		6.1	13.9	70/59	83600	60300	3.280	94800	25.5	66200	6.082	45400	90	3.19
		6.1	13.9	75/63	89100	62500	3.338	100500	26.7	65500	6.423	43600	95	2.99
		6.1	13.9	80/67	94600	64700	3.397	106200	27.8	64700	6.764	41600	100	2.80
		6.1	13.9	85/71	100000	67000	3.456	111800	28.9					
32.0		10.5	23.9	65/55	79200	58500	3.097	89800	25.6	76100	5.920	55900	88	3.76
		10.5	23.9	70/59	84700	60700	3.155	95500	26.8	75400	6.261	54000	93	3.53
		10.5	23.9	75/63	90200	63000	3.214	101200	28.1	74600	6.602	52100	98	3.31
		10.5	23.9	80/67	95600	65200	3.273	106800	29.2	73900	6.944	50200	103	3.12
		10.5	23.9	85/71	101100	67400	3.332	112500	30.3					
40		16.0	2.7	6.2	65/55	82400	61200	3.849	95500	21.4	65500	5.716	46000	85
	2.7		6.2	70/59	87800	63400	3.908	101100	22.5	64800	6.057	44100	90	3.13
	2.7		6.2	75/63	93300	65600	3.967	106800	23.5	64100	6.399	42300	95	2.93
	2.7		6.2	80/67	98800	67900	4.026	112500	24.5	63400	6.740	40400	99	2.75
	2.7		6.2	85/71	104200	70100	4.084	118100	25.5					
	24.0	5.9	13.5	65/55	83400	61600	3.725	96100	22.4	74700	5.895	54600	88	3.71
		5.9	13.5	70/59	88900	63800	3.784	101800	23.5	74000	6.237	52700	93	3.47
		5.9	13.5	75/63	94400	66100	3.843	107500	24.6	73300	6.578	50800	97	3.26
		5.9	13.5	80/67	99800	68300	3.901	113100	25.6	72600	6.919	49000	102	3.07
		5.9	13.5	85/71	105300	70500	3.960	118800	26.6					
	32.0	10.2	23.2	65/55	84500	62000	3.601	96800	23.5	83900	6.074	63200	91	4.04
		10.2	23.2	70/59	90000	64300	3.660	102500	24.6	83200	6.416	61300	96	3.80
		10.2	23.2	75/63	95400	66500	3.718	108100	25.7	82500	6.757	59400	100	3.58
		10.2	23.2	80/67	100900	68700	3.777	113800	26.7	81800	7.098	57600	105	3.37
		10.2	23.2	85/71	106400	70900	3.836	119500	27.7					
	50	16.0	2.7	6.1	65/55	84700	63000	4.352	99600	19.5	73400	5.871	53400	88
2.7			6.1	70/59	90200	65300	4.411	105300	20.4	72700	6.212	51500	92	3.43
2.7			6.1	75/63	95600	67500	4.470	110900	21.4	71900	6.553	49500	97	3.21
2.7			6.1	80/67	101100	69700	4.528	116600	22.3	71200	6.895	47700	102	3.02
2.7			6.1	85/71	106600	71900	4.587	122300	23.2					
24.0		5.7	13.1	65/55	85700	63500	4.228	100100	20.3	82600	6.050	62000	90	4.00
		5.7	13.1	70/59	91200	65700	4.287	105800	21.3	81800	6.391	60000	95	3.75
		5.7	13.1	75/63	96700	67900	4.345	111500	22.3	81100	6.733	58100	100	3.53
		5.7	13.1	80/67	102200	70100	4.404	117200	23.2	80400	7.074	56300	105	3.33
		5.7	13.1	85/71	107600	72300	4.463	122800	24.1					
32.0		9.9	22.6	65/55	86800	63900	4.104	100800	21.2	91700	6.229	70400	93	4.31
		9.9	22.6	70/59	92300	66100	4.163	106500	22.2	91000	6.570	68600	98	4.06
		9.9	22.6	75/63	97700	68300	4.221	112100	23.1	90300	6.912	66700	103	3.83
		9.9	22.6	80/67	103200	70500	4.280	117800	24.1	89600	7.253	64800	108	3.62
		9.9	22.6	85/71	108700	72800	4.339	123500	25.1					
60		16.0	2.6	5.9	65/55	84600	63500	4.873	101200	17.4	81200	6.025	60600	90
	2.6		5.9	70/59	90000	65700	4.931	106800	18.3	80500	6.367	58800	95	3.70
	2.6		5.9	75/63	95500	67900	4.990	112500	19.1	79800	6.708	56900	99	3.48
	2.6		5.9	80/67	101000	70200	5.049	118200	20.0	79100	7.049	55000	104	3.29
	2.6		5.9	85/71	106500	72400	5.108	123900	20.8					
	24.0	5.6	12.8	65/55	85600	63900	4.749	101800	18.0	90400	6.205	69200	93	4.27
		5.6	12.8	70/59	91100	66100	4.807	107500	19.0	89700	6.546	67400	98	4.01
		5.6	12.8	75/63	96600	68400	4.866	113200	19.9	89000	6.887	65500	102	3.78
		5.6	12.8	80/67	102000	70600	4.925	118800	20.7	88200	7.229	63500	107	3.57
		5.6	12.8	85/71	107500	72800	4.984	124500	21.6					
	32.0	9.7	22.1	65/55	86700	64300	4.624	102500	18.8	99600	6.384	77800	96	4.57
		9.7	22.1	70/59	92200	66600	4.683	108200	19.7	98900	6.725	75900	100	4.31
		9.7	22.1	75/63	97600	68800	4.742	113800	20.6	98100	7.066	74000	105	4.07
		9.7	22.1	80/67	103100	71000	4.801	119500	21.5	97400	7.408	72100	110	3.85
		9.7	22.1	85/71	108600	73200	4.859	125200	22.4					

Size 096 (3000 SCFM) (Continued)

EWT (°F)	GPM	WPD		EAT (°F)	Cooling					Heating					
		PSI	FT of W.C.		Total (Btu/hr)	Sensible (Btu/hr)	Power Input (kW)	THR (Btu/hr)	EER	Total (Btu/hr)	Power Input (kW)	THA (Btu/hr)	LAT (°F)	COP	
70	16.0	2.5	5.8	65/55	82500	62900	5.430	101000	15.2	89000	6.180	67900	92	4.22	
		2.5	5.8	70/59	88000	65100	5.489	106700	16.0	88300	6.521	66000	97	3.96	
		2.5	5.8	75/63	93400	67300	5.548	112300	16.8	87600	6.863	64200	102	3.74	
		2.5	5.8	80/67	98900	69500	5.606	118000	17.6	86900	7.204	62300	107	3.53	
	24.0	2.5	5.8	85/71	104400	71800	5.665	123700	18.4						
		5.5	12.5	65/55	83600	63300	5.306	101700	15.8	98200	6.359	76500	95	4.52	
		5.5	12.5	70/59	89000	65500	5.365	107300	16.6	97500	6.701	74600	100	4.26	
		5.5	12.5	75/63	94500	67800	5.423	113000	17.4	96800	7.042	72800	105	4.02	
		5.5	12.5	80/67	100000	70000	5.482	118700	18.2	96100	7.383	70900	109	3.81	
		5.5	12.5	85/71	105500	72200	5.541	124400	19.0						
		9.5	21.6	65/55	84600	63700	5.182	102300	16.3	107400	6.538	85100	98	4.81	
		9.5	21.6	70/59	90100	66000	5.241	108000	17.2	106700	6.880	83200	103	4.54	
	32.0	9.5	21.6	75/63	95600	68200	5.299	113700	18.0	106000	7.221	81400	108	4.30	
		9.5	21.6	80/67	101000	70400	5.358	119300	18.9	105300	7.562	79500	112	4.08	
		9.5	21.6	85/71	106500	72600	5.417	125000	19.7						
		9.5	21.6	85/71	106500	72600	5.417	125000	19.7						
80	16.0	2.5	5.7	65/55	79000	61500	6.044	99600	13.1	96900	6.335	75300	95	4.48	
		2.5	5.7	70/59	84500	63800	6.102	105300	13.8	96200	6.676	73400	100	4.22	
		2.5	5.7	75/63	90000	66000	6.161	111000	14.6	95400	7.017	71500	104	3.98	
		2.5	5.7	80/67	95400	68200	6.220	116600	15.3	94700	7.359	69600	109	3.77	
		2.5	5.7	85/71	100900	70400	6.279	122300	16.1						
	24.0	5.4	12.3	65/55	80100	62000	5.920	100300	13.5	106100	6.514	83900	98	4.77	
		5.4	12.3	70/59	85500	64200	5.978	105900	14.3	105300	6.855	81900	102	4.50	
		5.4	12.3	75/63	91000	66400	6.037	111600	15.1	104600	7.197	80000	107	4.26	
		5.4	12.3	80/67	96500	68600	6.096	117300	15.8	103900	7.538	78200	112	4.04	
		5.4	12.3	85/71	102000	70800	6.155	123000	16.6						
	32.0	9.3	21.2	65/55	81100	62400	5.795	100900	14.0	115200	6.693	92400	100	5.04	
		9.3	21.2	70/59	86600	64600	5.854	106600	14.8	114500	7.034	90500	105	4.77	
		9.3	21.2	75/63	92100	66800	5.913	112300	15.6	113800	7.376	88600	110	4.52	
		9.3	21.2	80/67	97600	69000	5.972	118000	16.3	113100	7.717	86800	115	4.29	
		9.3	21.2	85/71	103000	71200	6.030	123600	17.1						
	90	16.0	2.5	5.6	65/55	74600	59700	6.733	97600	11.1	104700	6.489	82600	97	4.72
			2.5	5.6	70/59	80000	61900	6.791	103200	11.8	104000	6.831	80700	102	4.46
			2.5	5.6	75/63	85500	64200	6.850	108900	12.5	103300	7.172	78800	107	4.22
			2.5	5.6	80/67	91000	66400	6.909	114600	13.2	102600	7.513	77000	111	4.00
			2.5	5.6	85/71	96500	68600	6.968	120300	13.8					
24.0		5.3	12.1	65/55	75600	60200	6.608	98200	11.4	113900	6.669	91100	100	5.00	
		5.3	12.1	70/59	81100	62400	6.667	103900	12.2	113200	7.010	89300	105	4.73	
		5.3	12.1	75/63	86600	64600	6.726	109600	12.9	112500	7.351	87400	110	4.48	
		5.3	12.1	80/67	92100	66800	6.785	115300	13.6	111700	7.693	85400	114	4.25	
		5.3	12.1	85/71	97500	69000	6.843	120900	14.2						
32.0		9.1	20.9	65/55	76700	60600	6.484	98800	11.8	123100	6.848	99700	103	5.26	
		9.1	20.9	70/59	82200	62800	6.543	104500	12.6	122400	7.189	97900	108	4.99	
		9.1	20.9	75/63	87600	65000	6.602	110100	13.3	121600	7.530	95900	112	4.73	
		9.1	20.9	80/67	93100	67200	6.660	115800	14.0	120900	7.872	94000	117	4.50	
		9.1	20.9	85/71	98600	69400	6.719	121500	14.7						
100		16.0	2.4	5.5	65/55	69700	57800	7.516	95400	9.3					
			2.4	5.5	70/59	75200	60000	7.575	101100	9.9					
			2.4	5.5	75/63	80700	62200	7.633	106800	10.6					
			2.4	5.5	80/67	86100	64400	7.692	112400	11.2					
	2.4		5.5	85/71	91600	66700	7.751	118100	11.8						
	24.0	5.2	11.9	65/55	70800	58200	7.392	96000	9.6						
		5.2	11.9	70/59	76200	60400	7.451	101600	10.2						
		5.2	11.9	75/63	81700	62600	7.509	107300	10.9						
		5.2	11.9	80/67	87200	64900	7.568	113000	11.5						
		5.2	11.9	85/71	92700	67100	7.627	118700	12.2						
	32.0	9.0	20.6	65/55	71800	58600	7.268	96600	9.9						
		9.0	20.6	70/59	77300	60900	7.326	102300	10.6						
		9.0	20.6	75/63	82800	63100	7.385	108000	11.2						
9.0		20.6	80/67	88300	65300	7.444	113700	11.9							
110	16.0	2.4	5.5	65/55	64900	56000	8.413	93600	7.7						
		2.4	5.5	70/59	70400	58200	8.472	99300	8.3						
		2.4	5.5	75/63	75900	60500	8.530	105000	8.9						
		2.4	5.5	80/67	81300	62700	8.589	110600	9.5						
		2.4	5.5	85/71	86800	64900	8.648	116300	10.0						
	24.0	5.2	11.8	65/55	66000	56500	8.289	94300	8.0						
		5.2	11.8	70/59	71400	58700	8.348	99900	8.6						
		5.2	11.8	75/63	76900	60900	8.406	105600	9.1						
		5.2	11.8	80/67	82400	63100	8.465	111300	9.7						
		5.2	11.8	85/71	87900	65300	8.524	117000	10.3						
	32.0	8.9	20.3	65/55	67000	56900	8.165	94900	8.2						
		8.9	20.3	70/59	72500	59100	8.223	100600	8.8						
		8.9	20.3	75/63	78000	61300	8.282	106300	9.4						
8.9		20.3	80/67	83500	63500	8.341	112000	10.0							
8.9	20.3	85/71	88900	65700	8.400	117600	10.6								

Tint = Operation Not Recommended

Notes:

1. Operation below 40°F EWT is based upon a 15% methanol antifreeze solution.
2. Performance stated is at the rated power supply; performance may vary as the power supply varies from the rated.
3. See performance correction tables for operating conditions other than those listed.
4. Interpolation is permissible; extrapolation is not.
5. For performance data outside the EAT listed, refer to the Daikin SelectTools selection program
6. Table does not reflect fan or pump power corrections for AHR/ISO conditions.
7. Data is base on unit at full load operation..

Size 120 (4000 SCFM)

EWT (°F)	GPM	WPD		EAT (°F)	Cooling					Heating						
		PSI	FT of W.C.		Total (Btu/hr)	Sensible (Btu/hr)	Power Input (kW)	THR (Btu/hr)	EER	Total (Btu/hr)	Power Input (kW)	THA (Btu/hr)	LAT (°F)	COP		
20	20.0	4.4	10.1	65/55	Tint = Operation Not Recommended (See page 29 for Capacity Table Legend)						65200	7.315	40200	80	2.61	
		4.4	10.1	70/59							64300	7.748	37900	85	2.43	
		4.4	10.1	75/63							63400	8.180	35500	90	2.27	
		4.4	10.1	80/67							62500	8.613	33100	94	2.12	
		4.4	10.1	85/71												
	30.0	9.6	21.9	65/55							79500	7.595	53600	83	3.06	
		9.6	21.9	70/59							78600	8.028	51200	88	2.87	
		9.6	21.9	75/63							77700	8.460	48800	93	2.69	
		9.6	21.9	80/67							76800	8.893	46400	98	2.53	
		9.6	21.9	85/71												
	40.0	16.5	37.7	65/55							93900	7.875	67000	87	3.49	
		16.5	37.7	70/59							93000	8.308	64600	91	3.28	
		16.5	37.7	75/63							92100	8.740	62300	96	3.09	
		16.5	37.7	80/67							91200	9.173	59900	101	2.91	
		16.5	37.7	85/71												
30	20.0	4.3	9.8	65/55						80400	7.558	54600	84	3.11		
		4.3	9.8	70/59	104100	75400	5.334	122300	19.5	79500	7.991	52200	88	2.91		
		4.3	9.8	75/63	110900	78300	5.407	129400	20.5	78600	8.423	49900	93	2.73		
		4.3	9.8	80/67	117700	81200	5.479	136400	21.5	77700	8.856	47500	98	2.57		
		4.3	9.8	85/71	124400	84100	5.552	143300	22.4							
	30.0	9.3	21.2	65/55	99000	73200	5.068	116300	19.5	94800	7.838	68000	87	3.54		
		9.3	21.2	70/59	105800	76100	5.140	123300	20.6	93900	8.271	65700	92	3.32		
		9.3	21.2	75/63	112600	78900	5.213	130400	21.6	93000	8.703	63300	96	3.13		
		9.3	21.2	80/67	119300	81800	5.285	137300	22.6	92100	9.136	60900	101	2.95		
		9.3	21.2	85/71	126100	84700	5.358	144400	23.5							
	40.0	16.0	36.5	65/55	100700	73800	4.874	117300	20.7	109100	8.118	81400	90	3.94		
		16.0	36.5	70/59	107500	76700	4.946	124400	21.7	108200	8.551	79000	95	3.71		
		16.0	36.5	75/63	114200	79600	5.019	131300	22.8	107300	8.983	76600	100	3.50		
		16.0	36.5	80/67	121000	82500	5.091	138400	23.8	106400	9.416	74300	104	3.31		
		16.0	36.5	85/71	127700	85400	5.164	145300	24.7							
40	20.0	4.2	9.5	65/55	104000	76900	5.870	124000	17.7	94500	7.801	67900	87	3.55		
		4.2	9.5	70/59	110700	79800	5.943	131000	18.6	93600	8.234	65500	92	3.33		
		4.2	9.5	75/63	117500	82700	6.015	138000	19.5	92700	8.667	63100	96	3.13		
		4.2	9.5	80/67	124300	85600	6.088	145100	20.4	91800	9.099	60700	101	2.95		
		4.2	9.5	85/71	131000	88500	6.161	152000	21.3							
	30.0	9.0	20.6	65/55	105600	77600	5.676	125000	18.6	108900	8.081	81300	90	3.95		
		9.0	20.6	70/59	112400	80500	5.749	132000	19.6	108000	8.514	78900	95	3.71		
		9.0	20.6	75/63	119200	83400	5.821	139100	20.5	107100	8.947	76600	100	3.51		
		9.0	20.6	80/67	125900	86300	5.894	146000	21.4	106200	9.379	74200	104	3.32		
		9.0	20.6	85/71	132700	89200	5.967	153100	22.2							
	40.0	15.5	35.5	65/55	107300	78300	5.482	126000	19.6	123200	8.361	94700	93	4.31		
		15.5	35.5	70/59	114100	81100	5.555	133100	20.5	122300	8.794	92300	98	4.07		
		15.5	35.5	75/63	120800	84000	5.627	140000	21.5	121400	9.227	89900	103	3.85		
		15.5	35.5	80/67	127600	86900	5.700	147100	22.4	120500	9.659	87500	108	3.65		
		15.5	35.5	85/71	134300	89800	5.773	154000	23.3							
50	20.0	4.1	9.3	65/55	106900	79200	6.478	129000	16.5	105800	8.045	78300	89	3.85		
		4.1	9.3	70/59	113700	82100	6.550	136100	17.4	104900	8.477	76000	94	3.62		
		4.1	9.3	75/63	120400	85000	6.623	143000	18.2	104000	8.910	73600	99	3.42		
		4.1	9.3	80/67	127200	87900	6.696	150100	19.0	103100	9.342	71200	104	3.23		
		4.1	9.3	85/71	133900	90800	6.768	157000	19.8							
	30.0	8.8	20.0	65/55	108600	79900	6.284	130000	17.3	120200	8.325	91800	93	4.23		
		8.8	20.0	70/59	115300	82800	6.356	137000	18.1	119300	8.757	89400	97	3.99		
		8.8	20.0	75/63	122100	85700	6.429	144000	19.0	118400	9.190	87000	102	3.77		
		8.8	20.0	80/67	128800	88600	6.502	151000	19.8	117500	9.622	84700	107	3.58		
		8.8	20.0	85/71	135600	91500	6.574	158000	20.6							
	40.0	15.1	34.5	65/55	110200	80600	6.090	131000	18.1	134500	8.605	105100	96	4.58		
		15.1	34.5	70/59	117000	83500	6.162	138000	19.0	133600	9.037	102800	101	4.33		
		15.1	34.5	75/63	123700	86300	6.235	145000	19.8	132700	9.470	100400	106	4.10		
		15.1	34.5	80/67	130500	89200	6.308	152000	20.7	131800	9.902	98000	110	3.90		
		15.1	34.5	85/71	137300	92100	6.380	159100	21.5							
60	20.0	4.0	9.1	65/55	106700	79800	7.112	131000	15.0	113600	8.288	85300	91	4.01		
		4.0	9.1	70/59	113500	82700	7.185	138000	15.8	112700	8.720	82900	96	3.78		
		4.0	9.1	75/63	120300	85600	7.257	145100	16.6	111800	9.153	80600	101	3.58		
		4.0	9.1	80/67	127000	88500	7.330	152000	17.3	110900	9.586	78200	106	3.39		
		4.0	9.1	85/71	133800	91400	7.402	159100	18.1							
	30.0	8.6	19.5	65/55	108400	80500	6.918	132000	15.7	127900	8.568	98700	94	4.37		
		8.6	19.5	70/59	115200	83400	6.991	139100	16.5	127000	9.000	96300	99	4.13		
		8.6	19.5	75/63	121900	86300	7.063	146000	17.3	126100	9.433	93900	104	3.91		
		8.6	19.5	80/67	128700	89200	7.136	153100	18.0	125200	9.866	91500	109	3.72		
		8.6	19.5	85/71	135400	92000	7.208	160000	18.8							
	40.0	14.8	33.7	65/55	110100	81100	6.724	133000	16.4	142300	8.848	112100	98	4.71		
		14.8	33.7	70/59	116800	84000	6.797	140000	17.2	141400	9.280	109700	103	4.46		
		14.8	33.7	75/63	123600	86900	6.869	147000	18.0	140500	9.713	107300	107	4.24		
		14.8	33.7	80/67	130300	89800	6.942	154000	18.8	139600	10.146	105000	112	4.03		
		14.8	33.7	85/71	137100	92700	7.014	161000	19.5							

Size 120 (4000 SCFM) (Continued)

EWT (°F)	GPM	WPD		EAT (°F)	Cooling					Heating					
		PSI	FT of W.C.		Total (Btu/hr)	Sensible (Btu/hr)	Power Input (kW)	THR (Btu/hr)	EER	Total (Btu/hr)	Power Input (kW)	THA (Btu/hr)	LAT (°F)	COP	
70	20.0	3.9	8.9	65/55	104200	79100	7.801	130800	13.4	118100	8.531	89000	92	4.05	
		3.9	8.9	70/59	110900	82000	7.873	137800	14.1	117200	8.964	86600	97	3.83	
		3.9	8.9	75/63	117700	84800	7.946	144800	14.8	116300	9.396	84200	102	3.62	
		3.9	8.9	80/67	124400	87700	8.018	151800	15.5	115400	9.829	81900	107	3.44	
	30.0	3.9	8.9	85/71	131200	90600	8.091	158800	16.2						
		8.4	19.1	65/55	105800	79700	7.607	131800	13.9	132500	8.811	102400	96	4.40	
		8.4	19.1	70/59	112600	82600	7.679	138800	14.7	131600	9.244	100100	100	4.17	
		8.4	19.1	75/63	119300	85500	7.752	145800	15.4	130700	9.676	97700	105	3.96	
		8.4	19.1	80/67	126100	88400	7.824	152800	16.1	129800	10.109	95300	110	3.76	
		8.4	19.1	85/71	132900	91300	7.897	159900	16.8						
		14.5	33.0	65/55	107500	80400	7.413	132800	14.5	146800	9.091	115800	99	4.73	
		14.5	33.0	70/59	114200	83300	7.485	139700	15.3	145900	9.524	113400	104	4.49	
	40.0	14.5	33.0	75/63	121000	86200	7.558	146800	16.0	145000	9.956	111000	108	4.26	
		14.5	33.0	80/67	127800	89100	7.630	153800	16.7	144100	10.389	108600	113	4.06	
14.5		33.0	85/71	134500	91900	7.703	160800	17.5							
3.8		8.7	65/55	99800	77400	8.571	129100	11.6	120700	8.774	90800	93	4.03		
80	20.0	3.8	8.7	70/59	106500	80300	8.644	136000	12.3	119800	9.207	88400	98	3.81	
		3.8	8.7	75/63	113300	83100	8.716	143000	13.0	118900	9.639	86000	102	3.61	
		3.8	8.7	80/67	120000	86000	8.789	150000	13.7	118000	10.072	83600	107	3.43	
		3.8	8.7	85/71	126800	88900	8.861	157000	14.3						
		8.2	18.8	65/55	101400	78000	8.377	130000	12.1	135000	9.054	104100	96	4.37	
	30.0	8.2	18.8	70/59	108200	80900	8.450	137000	12.8	134100	9.487	101700	101	4.14	
		8.2	18.8	75/63	114900	83800	8.522	144000	13.5	133200	9.919	99300	106	3.93	
		8.2	18.8	80/67	121700	86700	8.595	151000	14.2	132300	10.352	97000	110	3.74	
		8.2	18.8	85/71	128500	89600	8.667	158100	14.8						
	40.0	14.2	32.4	65/55	103100	78700	8.183	131000	12.6	149400	9.334	117500	99	4.69	
		14.2	32.4	70/59	109800	81600	8.256	138000	13.3	148500	9.767	115200	104	4.45	
		14.2	32.4	75/63	116600	84500	8.328	145000	14.0	147600	10.199	112800	109	4.24	
		14.2	32.4	80/67	123400	87400	8.401	152100	14.7	146700	10.632	110400	114	4.04	
		14.2	32.4	85/71	130100	90200	8.473	159000	15.4						
90	20.0	3.8	8.6	65/55	94200	75100	9.451	126500	10.0	123600	9.017	92800	93	4.01	
		3.8	8.6	70/59	101000	78000	9.523	133500	10.6	122700	9.450	90400	98	3.80	
		3.8	8.6	75/63	107700	80900	9.596	140500	11.2	121800	9.883	88100	103	3.61	
		3.8	8.6	80/67	114500	83800	9.669	147500	11.8	120900	10.315	85700	108	3.43	
		3.8	8.6	85/71	121200	86700	9.741	154400	12.4						
	30.0	8.1	18.5	65/55	95900	75800	9.257	127500	10.4	138000	9.297	106300	97	4.35	
		8.1	18.5	70/59	102600	78600	9.329	134400	11.0	137100	9.730	103900	102	4.13	
		8.1	18.5	75/63	109400	81500	9.402	141500	11.6	136200	10.163	101500	106	3.92	
		8.1	18.5	80/67	116100	84400	9.475	148400	12.3	135300	10.595	99100	111	3.74	
		8.1	18.5	85/71	122900	87300	9.547	155500	12.9						
	40.0	14.0	31.8	65/55	97500	76400	9.063	128400	10.8	152300	9.577	119600	100	4.66	
		14.0	31.8	70/59	104300	79300	9.135	135500	11.4	151400	10.010	117200	105	4.43	
		14.0	31.8	75/63	111000	82200	9.208	142400	12.1	150500	10.443	114900	110	4.22	
		14.0	31.8	80/67	117800	85100	9.281	149500	12.7	149600	10.875	112500	114	4.03	
14.0		31.8	85/71	124600	88000	9.353	156500	13.3							
100	20.0	3.7	8.4	65/55	88100	72700	10.468	123800	8.4						
		3.7	8.4	70/59	94800	75600	10.540	130800	9.0						
		3.7	8.4	75/63	101600	78500	10.613	137800	9.6						
		3.7	8.4	80/67	108400	81300	10.685	144900	10.1						
		3.7	8.4	85/71	115100	84200	10.758	151800	10.7						
	30.0	8.0	18.2	65/55	89800	73300	10.274	124900	8.7						
		8.0	18.2	70/59	96500	76200	10.346	131800	9.3						
		8.0	18.2	75/63	103300	79100	10.419	138900	9.9						
		8.0	18.2	80/67	110000	82000	10.491	145800	10.5						
	40.0	8.0	18.2	85/71	116800	84900	10.564	152900	11.1						
		13.8	31.4	65/55	91400	74000	10.080	125800	9.1						
		13.8	31.4	70/59	98200	76900	10.152	132800	9.7						
		13.8	31.4	75/63	104900	79800	10.225	139800	10.3						
		13.8	31.4	80/67	111700	82700	10.297	146800	10.8						
110	20.0	3.7	8.4	65/55	82100	70500	11.649	121900	7.0						
		3.7	8.4	70/59	88800	73400	11.722	128800	7.6						
		3.7	8.4	75/63	95600	76300	11.794	135900	8.1						
		3.7	8.4	80/67	102300	79100	11.867	142800	8.6						
		3.7	8.4	85/71	109100	82000	11.939	149800	9.1						
	30.0	7.9	18.0	65/55	83700	71100	11.455	122800	7.3						
		7.9	18.0	70/59	90500	74000	11.528	129800	7.9						
		7.9	18.0	75/63	97200	76900	11.600	136800	8.4						
		7.9	18.0	80/67	104000	79800	11.673	143800	8.9						
	40.0	7.9	18.0	85/71	110800	82700	11.745	150900	9.4						
		13.6	31.1	65/55	85400	71800	11.261	123800	7.6						
		13.6	31.1	70/59	92100	74700	11.334	130800	8.1						
		13.6	31.1	75/63	98900	77600	11.406	137800	8.7						
		13.6	31.1	80/67	105700	80500	11.479	144900	9.2						
			13.6	31.1	85/71	112400	83400	11.551	151800	9.7					

Tint = Operation Not Recommended

Notes:

- Operation below 40°F EWT is based upon a 15% methanol antifreeze solution.*
- Performance stated is at the rated power supply; performance may vary as the power supply varies from the rated.*
- See performance correction tables for operating conditions other than those listed.*
- Interpolation is permissible; extrapolation is not.*
- For performance data outside the EAT listed, refer to the Daikin SelectTools selection program*
- Table does not reflect fan or pump power corrections for AHR/ISO conditions.*
- Data is base on unit at full load operation..*

Capacity table legend:

Btu/hr = British Thermal Units per Hour

CFM = Airflow Rate, Cubic Feet per Minute

COP = Coefficient of Performance

EAT = Entering Air Temperature

EER = Energy Efficiency Ratio

EWT = Entering Water Temperature

Ft of W.C. = Feet of Water Column

GPM = Gallons per Minute

kW = Kilowatts

LAT = Leaving Air Temperature

PSI = Pounds per Square Inch

THA = Total Heat of Absorption

THR = Total Heat of Rejection

WPD = Waterside Pressure Drop

Waterside economizer cooling capacity data

Table 8: Waterside economizer cooling capacity

Unit Size	GPM	1800 CFM		2400 CFM		3200 CFM		4000 CFM		5000 CFM		WSE Water side dP (ft. of wc.)		
		Total	Sensible	Total	Sensible	Total	Sensible	Total	Sensible	Total	Sensible	Coil Only	Pipes, valve in by-pass	Pipes, valve thru WSE coil
072	12	42.3	37.8	46.8	45.1	51.9	51.9					1.7	8.1	9.0
	18	52.2	41.7	58.8	51.2	65.1	60.9					3.7	18.2	20.1
	24	59.4	45.0	67.5	54.1	75.9	66.4					6.5	32.4	35.5
	² PD (" wc.)	0.08		0.12		0.17								
096	16			55.3	49.4	61.0	58.7	66.0	65.2			3.0	14.4	15.9
	24			67.5	54.1	75.9	66.4	82.2	75.8			6.5	32.4	35.5
	32			76.4	58.3	86.4	69.8	94.6	82.2			11.5	57.5	62.7
	² PD (" wc.)			0.12		0.17		0.24						
120	20					69.2	63.0	74.5	71.7	80.7	79.5	4.6	22.5	24.8
	30					84.3	68.8	91.9	80.9	99.4	92.1	10.1	50.6	55.2
	32					94.9	74.0	103.9	84.6	113.5	99.6	17.8	89.9	97.4
	² PD (" wc.)					0.20		0.26		0.34				

Notes: ¹ Capacity is based on 80/67°F entering air and 45°F entering water temperatures. Total and sensible capacities are Mbtuh.

² Air PD is air pressure drop in inches of water column wet coil.

Physical data

Table 9: Large horizontal size 072 - 120

Unit Size		072	096	120
Fan Wheel - D x W (In.)		13 × 12	13 × 12	16 × 15
Fan Motor Horsepower		1.5 / 3.0	1.5 / 3.0	3.0 / 5.0
Coil Face Area (Sq. Ft.)		9.0	9.0	10.5
Coil Rows		3	3	3
Refrigerant Charge (Oz.)	Compressor 1	67	67	74
	Compressor 2	67	67	74
Filter, (Qty.) Size (In.)		(3) 28" × 19" × 2	(3) 28" × 19" × 2	(3) 28" × 19" × 2
Water Connections		1¼" FPT	1¼" FPT	1¼" FPT
Condensate Connections		7/8" ODM	7/8" ODM	7/8" ODM
Weight Based on Motor HP		1.5 / 3.0	1.5 / 3.0	3.0 / 5.0
Weight, Operating (Lbs.)		642 / 657	692 / 707	704 / 724
Weight, Shipping (Lbs.)		720 / 735	770 / 785	792 / 812
Weight, Operating (Lbs.) with Economizer		742 / 757	792 / 807	804 / 824
Weight, Shipping (Lbs.) with Economizer		840 / 855	890 / 905	912 / 932

Electrical data

Table 10: Large horizontal unit

Unit Size	Voltage/Hz/Phase	Fan Motor (HP)	Compressor 1		Compressor 2		Fan Motor FLA	Total Unit FLA	Min. Volts	Min. Circuit Ampacity	Max. Fuse Size
	Volt		RLA	LRA	RLA	LRA					
072	208/230-60-3	1.5	13.2	88.0	13.2	88.0	5.0	31.4	187	34.7	45
	460-60-3	1.5	6.0	44.0	6.0	44.0	2.4	14.4	416	15.9	20
	575-60-3	1.5	4.2	30.0	4.2	30.0	2.0	10.4	520	11.5	15
	208/230-60-3	3.0	13.2	88.0	13.2	88.0	8.3	34.7	187	38.0	45
	460-60-3	3.0	6.0	44.0	6.0	44.0	3.8	15.8	416	17.3	20
	575-60-3	3.0	4.2	30.0	4.2	30.0	3.1	11.5	520	12.6	15
096	208/230-60-3	1.5	13.7	83.1	13.7	83.1	5.0	32.4	187	35.8	45
	460-60-3	1.5	6.2	41.0	6.2	41.0	2.4	14.8	416	16.4	20
	575-60-3	1.5	4.8	33.0	4.8	33.0	2.0	11.6	520	12.8	15
	208/230-60-3	3.0	13.7	83.1	13.7	83.1	8.3	35.7	187	39.1	45
	460-60-3	3.0	6.2	41.0	6.2	41.0	3.8	16.2	416	17.8	20
	575-60-3	3.0	4.8	33.0	4.8	33.0	3.1	12.6	520	13.8	15
120	208/230-60-3	3.0	15.6	110.0	15.6	110.0	8.3	39.5	187	43.4	50
	460-60-3	3.0	7.8	52.0	7.8	52.0	3.8	19.4	416	21.4	25
	575-60-3	3.0	5.8	38.9	5.8	38.9	3.1	14.7	520	16.2	20
	208/230-60-3	5.0	15.6	110.0	15.6	110.0	13.7	44.9	187	48.8	50
	460-60-3	5.0	7.8	52.0	7.8	52.0	6.2	21.8	416	23.8	25
	575-60-3	5.0	5.8	38.9	5.8	38.9	4.9	16.5	520	18.0	20

Operating limits

Table 11: Typical water source heat pump common design temperatures

Operating Mode	Entering Air °F				Entering Water °F			
	Minimum		Maximum		Standard Range		Geothermal Range	
	DB	WB	DB	WB	Minimum	Maximum	Minimum	Maximum
Cooling	75	63	80	67	85	100	85	100
Heating	60	–	70	–	60	70	40	70

Table 12: Water source heat pump operating temperature limits (for continuous duty)

Operating Mode	Entering Air °F				Entering Water °F			
	Minimum		Maximum		Standard Range		Geothermal Range	
	DB	WB	DB	WB	Minimum	Maximum	Minimum	Maximum
Cooling	65	55	85	71	55	110	50	110
Ambient	50	–	100	–	–	–	–	–
Heating	50	–	80	–	55	90	20	90
Ambient	50	–	85	–	–	–	–	–

Notes: 1. In the heating mode, the sum of the entering air + entering water must be $\geq 100^{\circ}\text{F}$.

2. MINIMUM WATER FLOW = 1.5 GPM/Ton.

3. Maximum and minimum values may not be combined. If one value is at maximum or minimum, the other two conditions may not exceed the normal condition for standard units. Geothermal range units may combine any two maximum conditions, but not more than two, with all other conditions being normal conditions.

Table 13: Water source heat pump operating temperature limits at start-up (not for continuous duty)

Operating Mode	Entering Air °F				Entering Water °F			
	Minimum		Maximum		Standard Range		Geothermal Range	
	DB	WB	DB	WB	Minimum	Maximum	Minimum	Maximum
Cooling	50	40	105	87	45	120	30	120
Ambient	45	–	110	–	–	–	–	–
Heating	40	–	85	–	40	95	20	100
Ambient	40	–	85	–	–	–	–	–

Standard range units:

Units are designed to start in an ambient of 50°F (10°C) with entering air at 50°F (10°C), with entering water at 50°F (10°C), with nominal air flow and water flow (3.0 GPM/Ton), for initial start-up in heating.

Note: This is not a normal or continuous operating condition. It is assumed that such start-up is for the purpose of bringing the building space up to occupancy temperature.

Geothermal range units:

Units are designed to start in an ambient of 40°F (5°C) with entering air at 40°F (5°C), with entering water at 20°F (-7°C), with nominal air flow and water flow (3.0 GPM/Ton), for initial start-up in heating.

Note: This is not a normal or continuous operating condition. It is assumed that such start-up is for the purpose of bringing the building space up to occupancy temperature.

Environment

This equipment is designed for indoor installation only. Sheltered locations such as attics, garages, etc., generally will not provide sufficient protection against extremes in temperature and/or humidity, and equipment performance, reliability, and service life may be adversely affected.

Power supply

A voltage variation of +/-10% of nameplate voltage is acceptable. Three-phase system imbalance shall not exceed 2%.

Airflow correction factors

Table 14: Airflow correction factors

	Percent of Nominal Airflow									
	55	60	65	70	75	80	85	90	95	100
Total Cooling Capacity	0.935	0.942	0.948	0.955	0.962	0.969	0.976	0.983	0.990	1.000
Sensible Cooling Capacity	0.779	0.803	0.828	0.852	0.877	0.901	0.926	0.950	0.975	1.000
kW - Cooling	0.925	0.933	0.942	0.950	0.959	0.967	0.976	0.984	0.993	1.000
Total Heat of Rejection	0.931	0.939	0.946	0.954	0.961	0.969	0.976	0.984	0.991	1.000
Total Heating Capacity	0.912	0.921	0.931	0.940	0.950	0.960	0.969	0.979	0.988	1.000
kW - Heating	1.025	1.022	1.019	1.017	1.014	1.011	1.009	1.006	1.003	1.000
Total Heat of Absorption	0.908	0.918	0.928	0.938	0.948	0.958	0.968	0.978	0.988	1.000

	Percent of Nominal Airflow									
	105	110	115	120	125	130	135	140	145	150
Total Cooling Capacity	1.004	1.011	1.017	1.024	1.031	1.038	1.045	1.052	1.059	1.066
Sensible Cooling Capacity	1.024	1.048	1.073	1.098	1.122	1.147	1.171	1.196	1.220	1.245
kW - Cooling	1.010	1.019	1.027	1.036	1.044	1.053	1.061	1.070	1.078	1.087
Total Heat of Rejection	1.006	1.014	1.021	1.029	1.036	1.044	1.051	1.059	1.066	1.074
Total Heating Capacity	1.007	1.017	1.027	1.036	1.046	1.055	1.065	1.074	1.084	1.094
kW - Heating	0.998	0.995	0.992	0.990	0.987	0.984	0.981	0.979	0.976	0.973
Total Heat of Absorption	1.008	1.018	1.028	1.038	1.048	1.058	1.068	1.078	1.088	1.098

	Percent of Nominal Airflow								
	155	160	165	170	175	180	185	190	195
Total Cooling Capacity	1.073	1.079	1.086	1.093	1.100	1.107	1.114	1.121	1.128
Sensible Cooling Capacity	1.269	1.294	1.318	1.343	1.367	1.392	1.417	1.441	1.466
kW - Cooling	1.095	1.104	1.113	1.121	1.130	1.138	1.147	1.155	1.164
Total Heat of Rejection	1.081	1.089	1.096	1.104	1.111	1.119	1.126	1.134	1.141
Total Heating Capacity	1.103	1.113	1.122	1.132	1.141	1.151	1.161	1.170	1.180
kW - Heating	0.971	0.968	0.965	0.962	0.960	0.957	0.954	0.952	0.949
Total Heat of Absorption	1.108	1.118	1.128	1.138	1.149	1.159	1.169	1.179	1.189

Antifreeze correction factors

Table 15: Ethylene glycol

	10%	20%	30%	40%	50%
Cooling Capacity	0.9950	0.9920	0.9870	0.9830	0.9790
Heating Capacity	0.9910	0.9820	0.9770	0.9690	0.9610
Pressure Drop	1.0700	1.1300	1.1800	1.2600	1.2800

Table 16: Propylene glycol

	10%	20%	30%	40%	50%
Cooling Capacity	0.9900	0.9800	0.9700	0.9600	0.9500
Heating Capacity	0.9870	0.9750	0.9620	0.9420	0.9300
Pressure Drop	1.0700	1.1500	1.2500	1.3700	1.4200

Table 17: Methanol

	10%	20%	30%	40%	50%
Cooling Capacity	0.9980	0.9720	–	–	–
Heating Capacity	0.9950	0.9700	–	–	–
Pressure Drop	1.0230	1.0570	–	–	–

Table 18: Ethanol

	10%	20%	30%	40%	50%
Cooling Capacity	0.9910	0.9510	–	–	–
Heating Capacity	0.9950	0.9600	–	–	–
Pressure Drop	1.0350	0.9600	–	–	–

Fan performance curves

Figure 21: Large horizontal – size 072

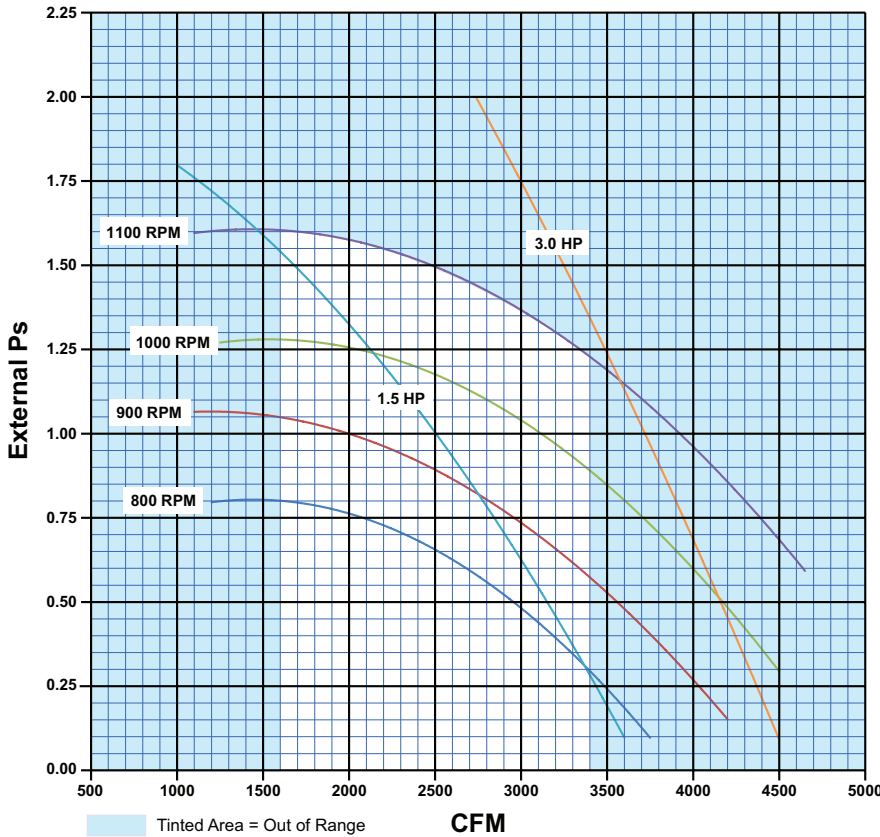

cfm = 0.472 = L/s
 hp × 0.746 = kW
 inches × 25.4 = mm

Table 19: Size 072 and 096 fan data

Unit Size	Motor HP	RPM Range	Factory Setting (RPM)	Motor Sheave Position
072	1.5	671-817	788	1 Turn Open
	3.0	910-1085	910	5 Turns Open
096	1.5	758-904	860	1½ Turns Open
	3.0	910-1085	910	5 Turns Open

Figure 22: Large horizontal – size 096

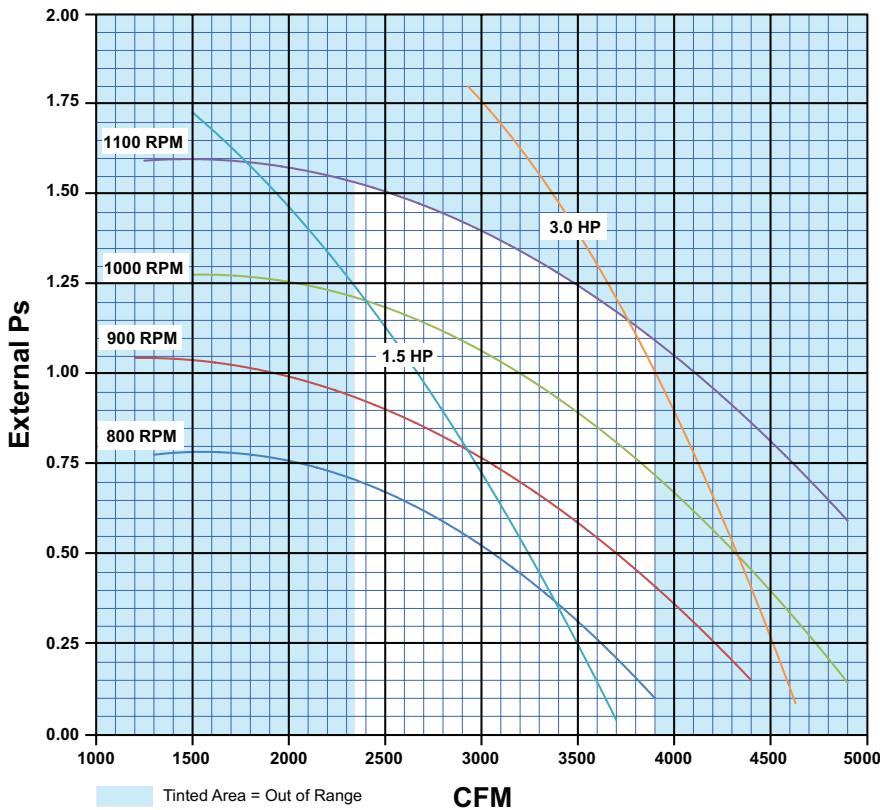

Note: For wet coil, calculate face velocity (cfm ÷ coil face area). Add the following external static pressure for the corresponding face velocity

English units
 300 fpm = .20"
 400 fpm = .31"
 500 fpm = .44"

Note: Re-enter curve at the increased static pressure to determine final cfm.

Figure 23: Large horizontal – size 120

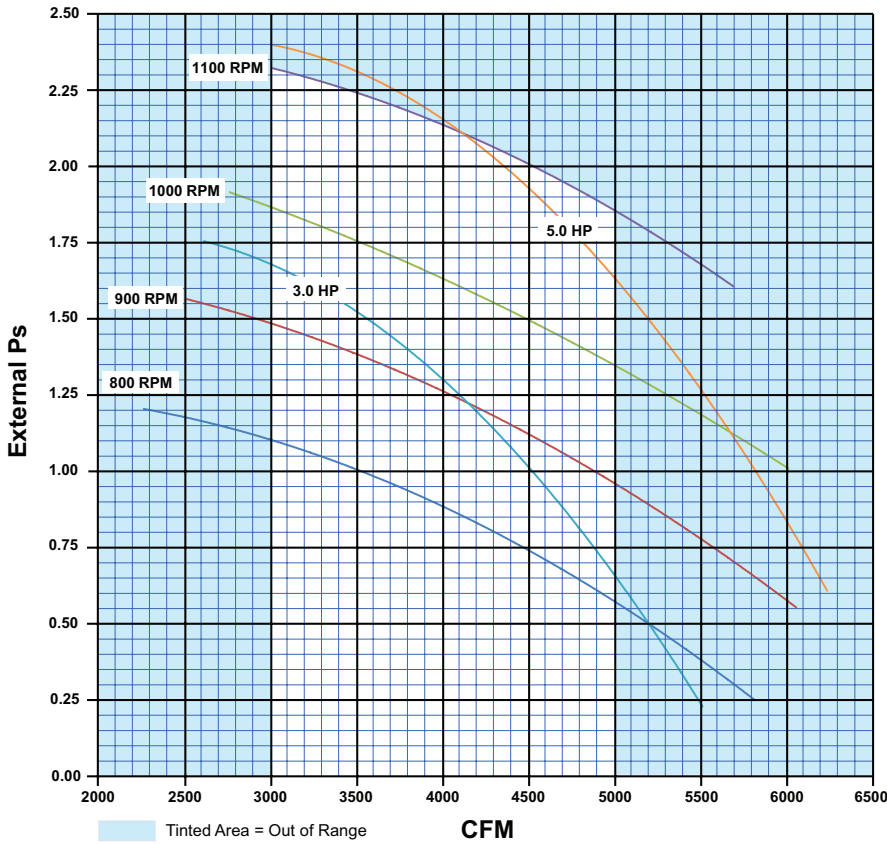

cfm = 0.472 = L/s

hp × 0.746 = kW

inches × 249 Pa = mm

Table 20: Size 120 fan data

Unit Size	Motor HP	RPM Range	Factory Setting (RPM)	Motor Sheave Position
120	3.0	677-824	735	3 Turns Open
	5.0	912-1111	912	5 Turns Open

Note: For wet coil, calculate face velocity (cfm ÷ coil face area). Add the following external static pressure for the corresponding face velocity

English units

300 fpm = .20"

400 fpm = .31"

500 fpm = .44"

Note: Re-enter curve at the increased static pressure to determine final cfm.

CCH/CCW large horizontal – 072 & 096

Figure 24: Large horizontal – size 072 & 096

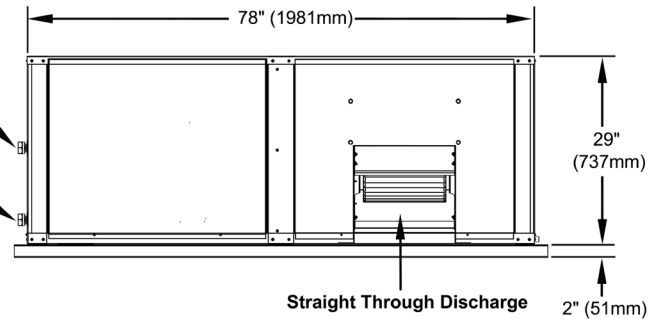
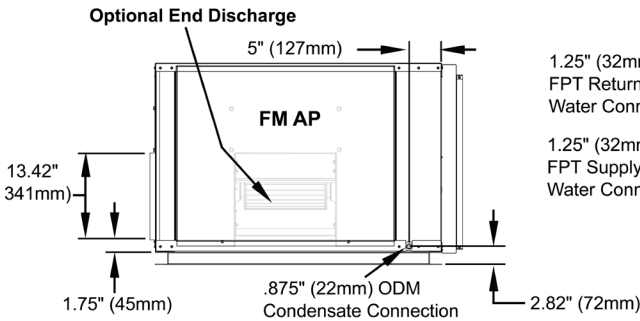
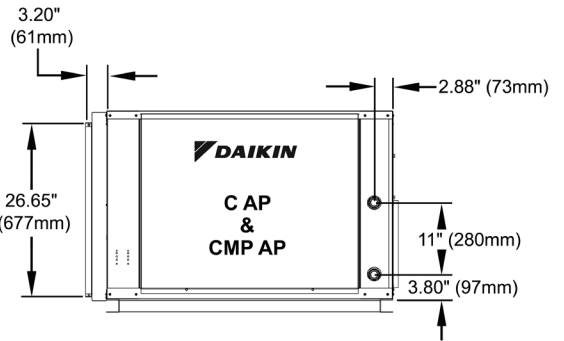
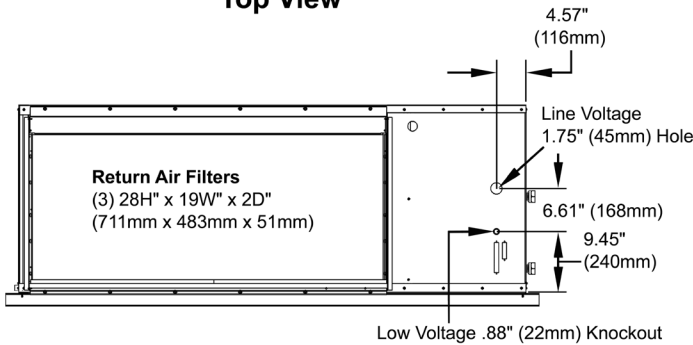
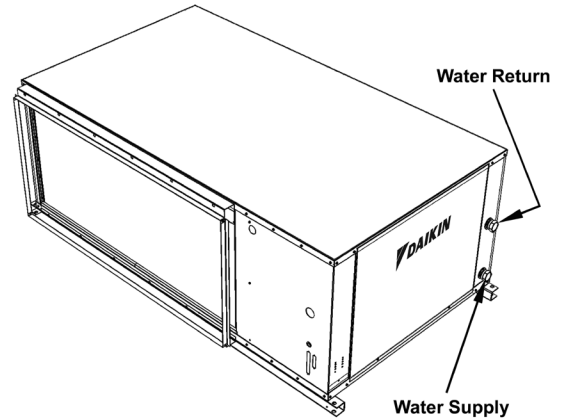
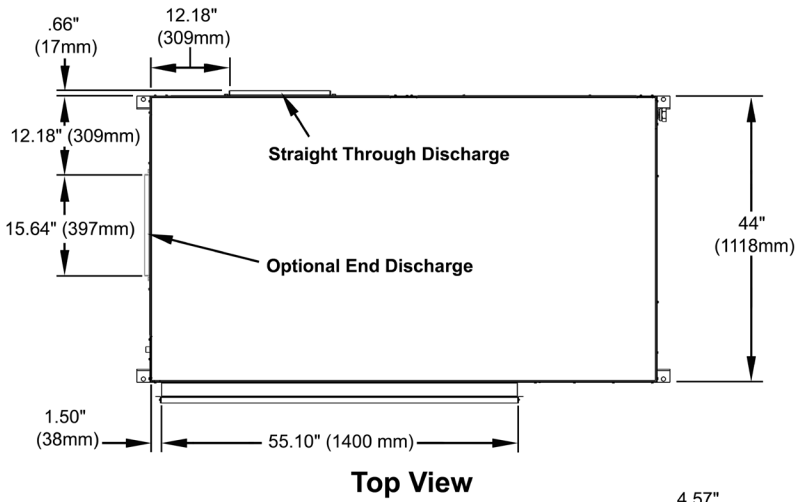

C AP = Control Access Panel CMP AP = Compressor Access Panel FM AP = Fan Motor Access Panel

Overall unit dimensions: 78"L x 44"W x 29"H (add 2" for hanger bracket)

CCH/CCW large horizontal – 120

Figure 25: Large horizontal – size 120

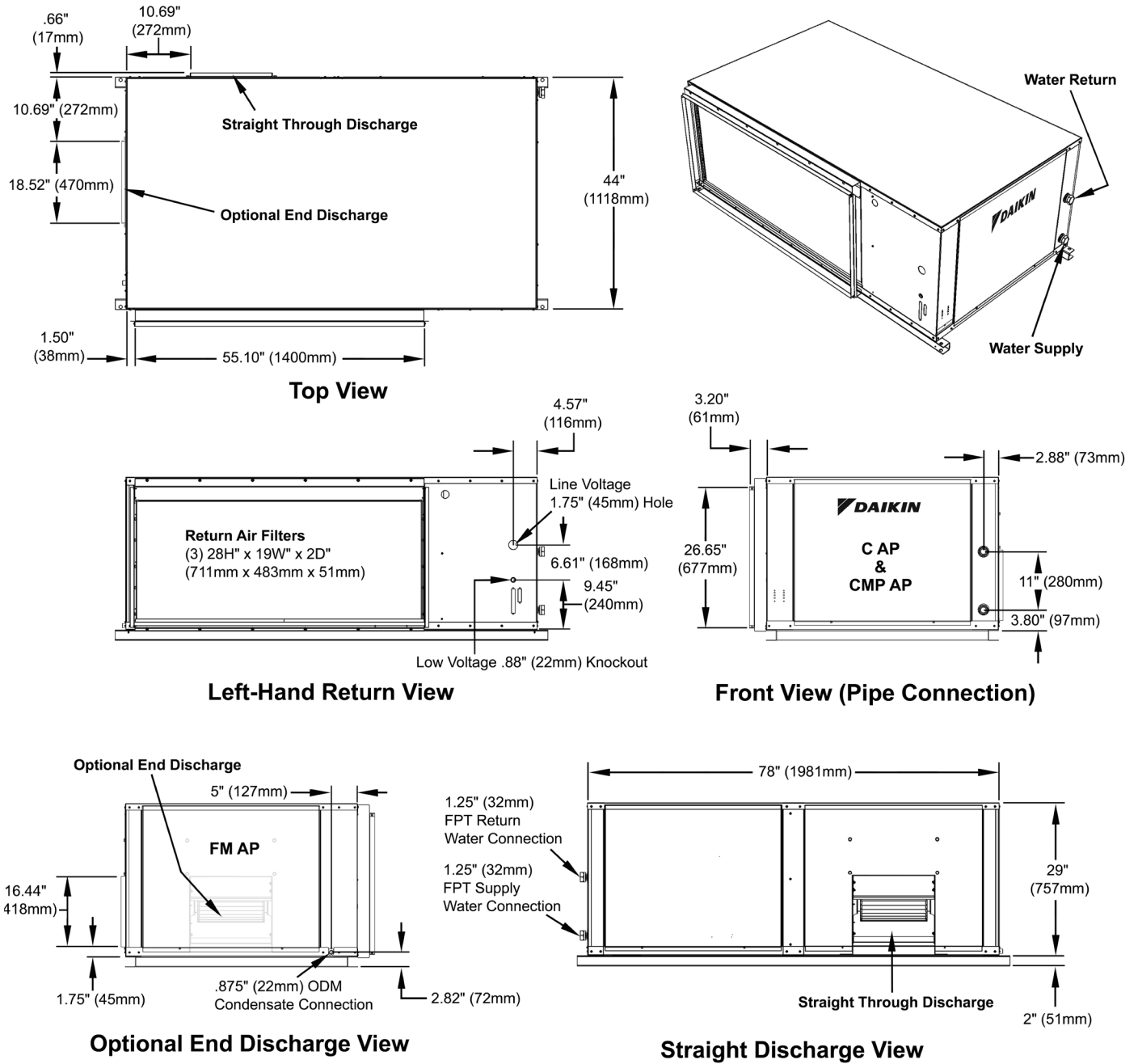

C AP = Control Access Panel CMP AP = Compressor Access Panel FM AP = Fan Motor Access Panel

Overall unit dimensions: 78"L x 44"W x 29"H (add 2" for hanger bracket)

Figure 26: Filter rack with return air duct flange dimensions

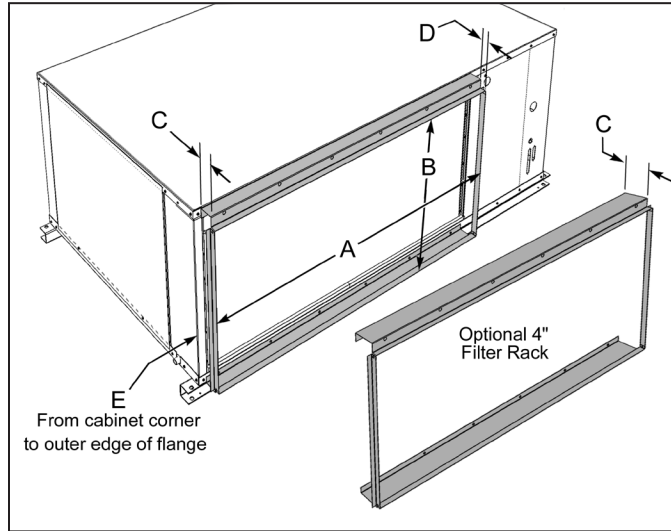

Table 21: Filter rack dimensions

Unit Size	A	B	C	D	E
072-120	55.10" (1400mm)	26.78" (680mm)	2.20" (56mm)	1.00" (25mm)	3.30" (84mm)
			Optional 4" Filter Rack		
			4.20" (107mm)		

Note: Dimensions are to the outside edge of the filter rack flanges.

Hanger brackets

Figure 27: Large horizontal - hanger brackets – sizes 072 thru 120

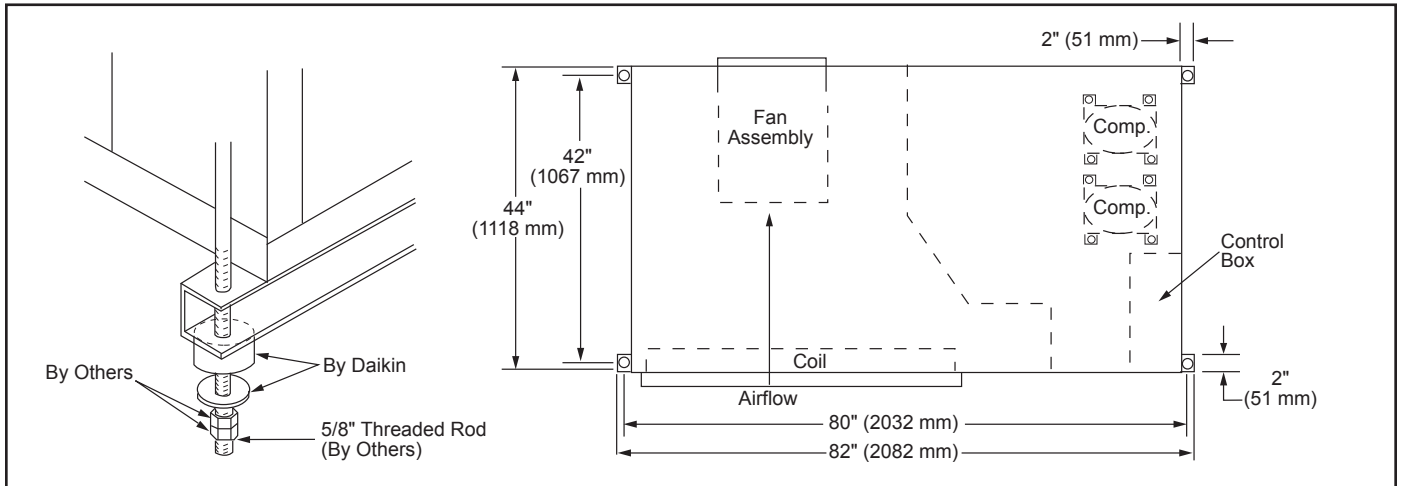

Typical WSE field provided and installed jumper piping routing details

Large horizontal unit – sizes 072-120, left-hand

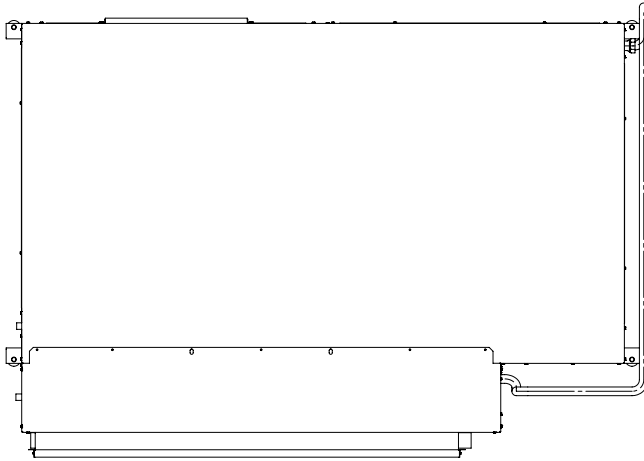

TOP VIEW

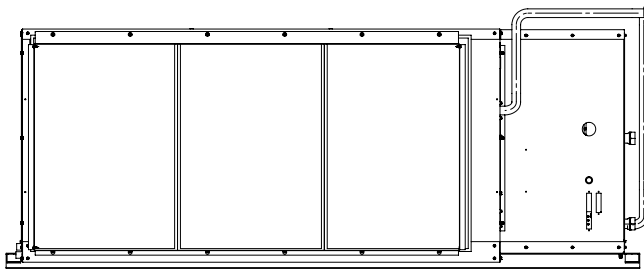

SIDE VIEW

IMPORTANT

Do not block access to removable access panels.

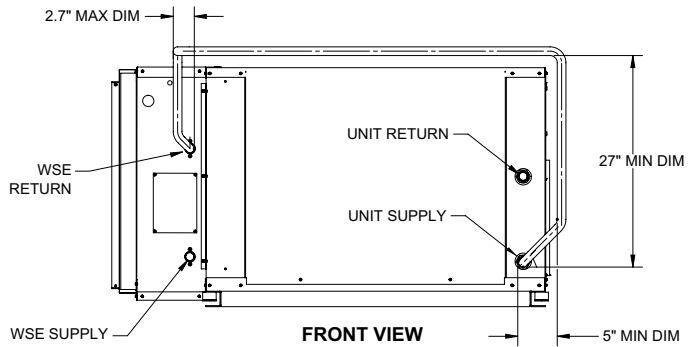

MicroTech III controller with I/O expansion module with HGRH 208/230, 460, 575-60-3 (1.5 hp or less)

Note: Wiring diagrams are typical. For the latest drawing version refer to the wiring diagram located on the inside of the controls access panel of the unit.

Gray tinted areas in the wiring diagram: Units with factory installed communication module include Discharge Air Temperature (DAT) and Return Air Temperature (RAT) sensors shipped loose and are field installed. The Leaving Water Temperature (LWT) sensor is factory installed.

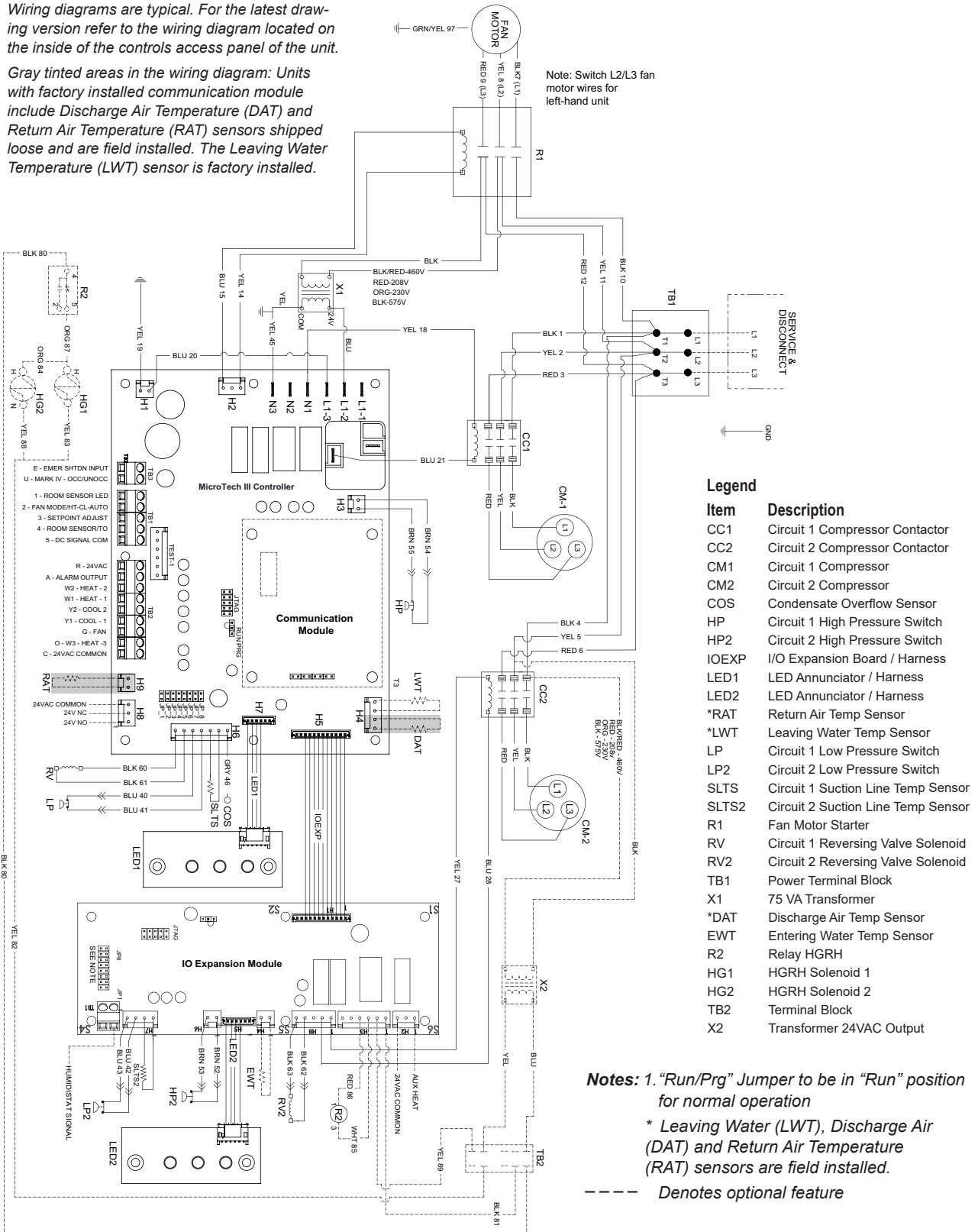

MicroTech III controller with I/O expansion module with hot gas reheat (HGRH) 208/230, 460, 575-60-3 (greater than 1.5 hp)

Note: Wiring diagrams are typical. For the latest drawing version refer to the wiring diagram located on the inside of the controls access panel of the unit.

Gray tinted areas in the wiring diagram: Units with factory installed communication module include Discharge Air Temperature (DAT) and Return Air Temperature (RAT) sensors shipped loose and are field installed. The Leaving Water Temperature (LWT) sensor is factory installed.

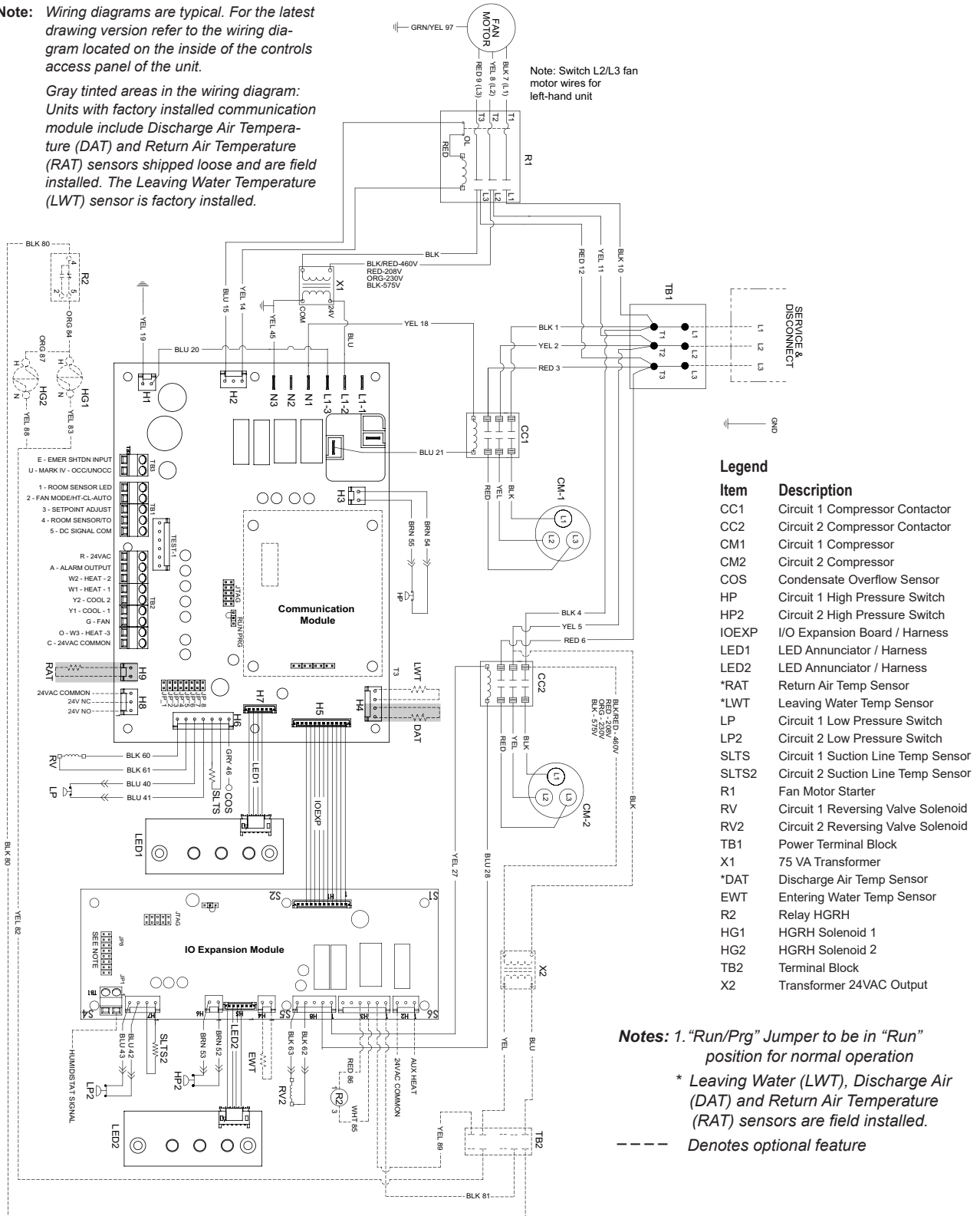

Legend

Item	Description
CC1	Circuit 1 Compressor Contactor
CC2	Circuit 2 Compressor Contactor
CM1	Circuit 1 Compressor
CM2	Circuit 2 Compressor
COS	Condensate Overflow Sensor
HP	Circuit 1 High Pressure Switch
HP2	Circuit 2 High Pressure Switch
IOEXP	I/O Expansion Board / Harness
LED1	LED Annunciator / Harness
LED2	LED Annunciator / Harness
*RAT	Return Air Temp Sensor
*LWT	Leaving Water Temp Sensor
LP	Circuit 1 Low Pressure Switch
LP2	Circuit 2 Low Pressure Switch
SLTS	Circuit 1 Suction Line Temp Sensor
SLTS2	Circuit 2 Suction Line Temp Sensor
R1	Fan Motor Starter
RV	Circuit 1 Reversing Valve Solenoid
RV2	Circuit 2 Reversing Valve Solenoid
TB1	Power Terminal Block
X1	75 VA Transformer
*DAT	Discharge Air Temp Sensor
EWT	Entering Water Temp Sensor
R2	Relay HGRH
HG1	HGRH Solenoid 1
HG2	HGRH Solenoid 2
TB2	Terminal Block
X2	Transformer 24VAC Output

Notes: 1. "Run/Prg" Jumper to be in "Run" position for normal operation
 * Leaving Water (LWT), Discharge Air (DAT) and Return Air Temperature (RAT) sensors are field installed.
 --- Denotes optional feature

MicroTech III controller with I/O expansion module – with waterside economizer 208/230, 460, 575-60-3

Note: Wiring diagrams are typical. For the latest drawing version refer to the wiring diagram located on the inside of the controls access panel of the unit.

Gray tinted areas in the wiring diagram: Units with factory installed communication module include Discharge Air Temperature (DAT) and Return Air Temperature (RAT) sensors shipped loose and are field installed. The Leaving Water Temperature (LWT) sensor is factory installed.

Note: Switch L2/L3 fan motor wires for left-hand unit

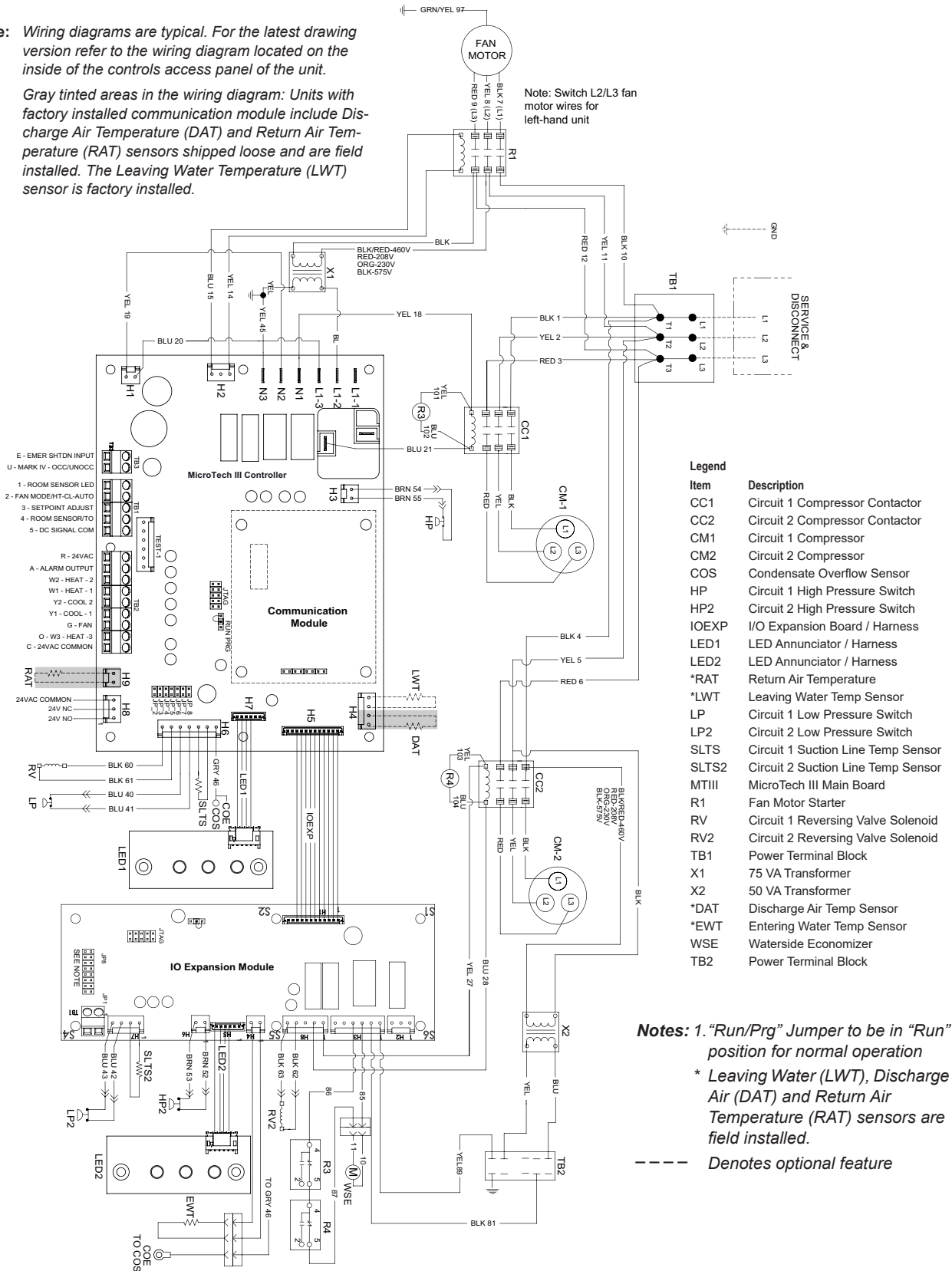

Item	Description
CC1	Circuit 1 Compressor Contactor
CC2	Circuit 2 Compressor Contactor
CM1	Circuit 1 Compressor
CM2	Circuit 2 Compressor
COS	Condensate Overflow Sensor
HP	Circuit 1 High Pressure Switch
HP2	Circuit 2 High Pressure Switch
IOEXP	I/O Expansion Board / Harness
LED1	LED Annunciator / Harness
LED2	LED Annunciator / Harness
*RAT	Return Air Temperature
*LWT	Leaving Water Temp Sensor
LP	Circuit 1 Low Pressure Switch
LP2	Circuit 2 Low Pressure Switch
SLTS	Circuit 1 Suction Line Temp Sensor
SLTS2	Circuit 2 Suction Line Temp Sensor
MTIII	MicroTech III Main Board
R1	Fan Motor Starter
RV	Circuit 1 Reversing Valve Solenoid
RV2	Circuit 2 Reversing Valve Solenoid
TB1	Power Terminal Block
X1	75 VA Transformer
X2	50 VA Transformer
*DAT	Discharge Air Temp Sensor
*EWT	Entering Water Temp Sensor
WSE	Waterside Economizer
TB2	Power Terminal Block

Notes: 1. "Run/Prg" Jumper to be in "Run" position for normal operation
 * Leaving Water (LWT), Discharge Air (DAT) and Return Air Temperature (RAT) sensors are field installed.
 --- Denotes optional feature

MicroTech III controller with I/O expansion module – with waterside economizer 208/230, 460, 575-60-3



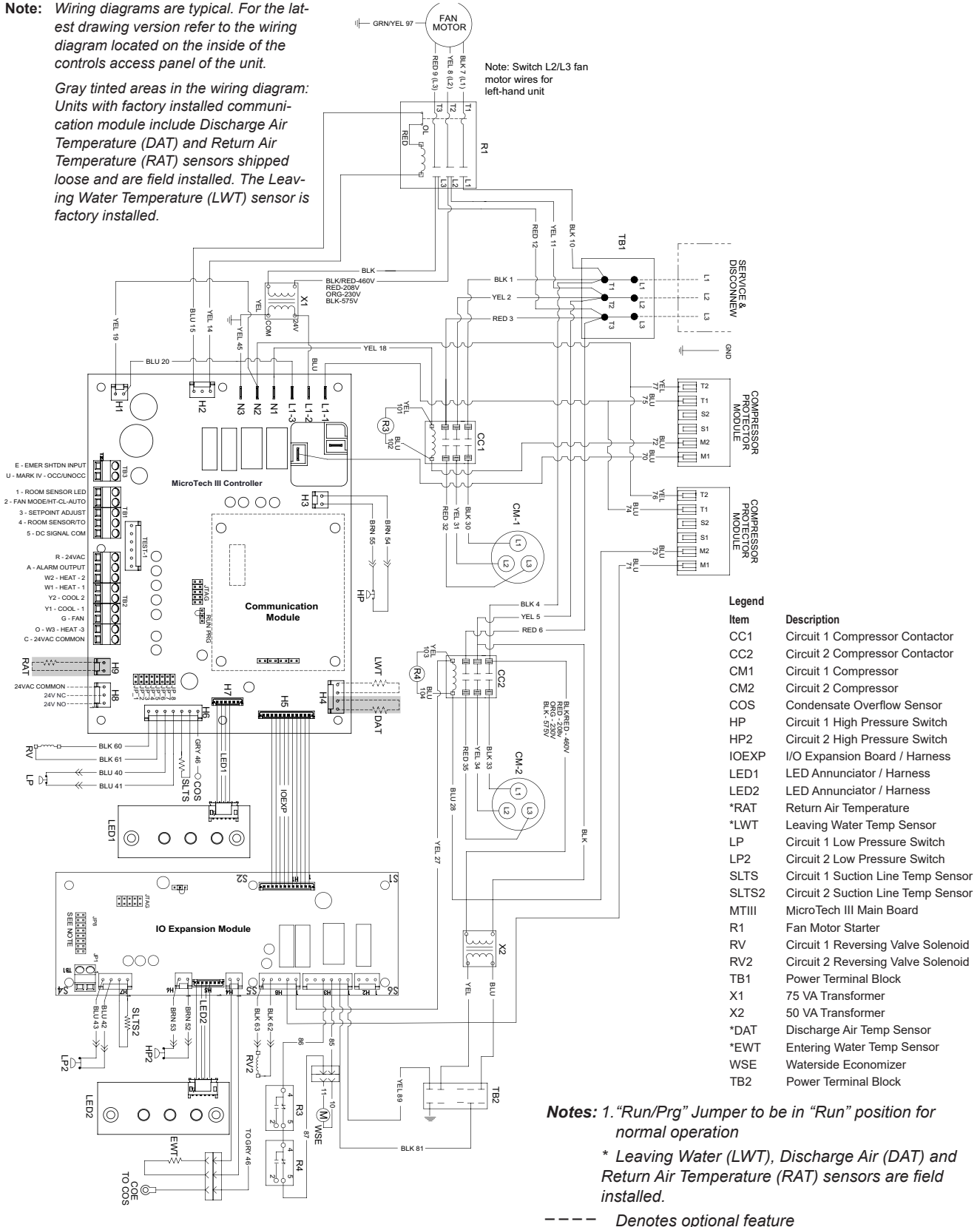

Note: Wiring diagrams are typical. For the latest drawing version refer to the wiring diagram located on the inside of the controls access panel of the unit.

Gray tinted areas in the wiring diagram: Units with factory installed communication module include Discharge Air Temperature (DAT) and Return Air Temperature (RAT) sensors shipped loose and are field installed. The Leaving Water Temperature (LWT) sensor is factory installed.





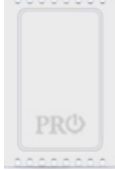

Thermostats and Remote Indoor Sensor

Table 22: Thermostat Selections

Wall Mounted Thermostats & Remote Sensor for use with all WSHP units: Console, V-Stack, Enfinity & SmartSource models		Thermostats				Remote Sensor
		Non-Programmable	Programmable (7 Day or 5+1+1) Non-Programmable		7 Day Programmable Non-Programmable	Remote Indoor Thermostat Sensor
		2H/2C	2H/2C	2H/3C Humidity Control	2H/3C Humidity Control WIFI	
						
Daikin Part Number		910411879	910411880	910417943	910417944	910420874
Feature						
LCD Display	Room Temperature & Setpoint	•	•	•	•	Allows Remote Temperature Sensing
	Room Humidity %			•	•	
Glow in the dark Display light		•	•	•	•	
Operating Modes	System	Heat-Off-Cool-Auto	Heat-Off-Cool-Auto	Heat-Off-Cool-Auto	Heat-Off-Cool-Auto	
	Fan	On-Auto	On-Auto	On-Auto-IAQ	On-Auto-IAQ	
Changeover	Manual	•	•	•	•	Use up to 16 sensors for temperature averaging
	Auto	•	•	•	•	
Temperature Control Range		44° F to 90° F (7° C to 32° C)	44° F to 90° F (7° C to 32° C)	44° F to 90° F (7° C to 32° C)	44° F to 90° F (7° C to 32° C)	
Adjustable Setpoint Limits		•	•	•	•	
Keypad Lockout				•	•	
Filter Change Reminder			•	•	•	
Programmable Fan		•	•	•	•	
Power Type	Battery	2 AA Alkaline Batteries				
	Hardwire (Common Wire)	18 to 30 VAC	18 to 30 VAC	18 to 30 VAC	18 to 30 VAC	
Permanent Memory Retention		•	•	•	•	
Remote Indoor Sensor Capable (Requires Daikin P/N: 910420874)			•	•	•	
Terminals		Rh, RC, G, Y, Y2, C, O, B, W/E, W2	Rh, RC, C, Y, Y2, W/E, W2, G, B, O, S1, S2	Rh, RC, C, Y, Y2, W/E, W2, G, B, O, S1, S2, H, D	Rh, RC, C, Y, Y2, W/E, W2, G, B, O, S1, S2, H, D	
Application						
Dehumidification	Smart Dehumidification			•	•	
	Simplified	•	•	•	•	
	Humidistat Controlled			•	•	
Electric Heat	Boilerless	•	•	•	•	
	Supplemental	•	•	•	•	
	Primary	•	•	•	•	
Waterside Economizer		•	•	•	•	
Hydronic Heat		•	•	•	•	

Room Temperature Sensors

Table 23: Room Temperature Sensors for BAS Operation

Room Sensors for use with all WSHP units with a BACnet or LonWorks Communication Module: Console, V-Stack, Enfinity & Smart-Source models		Room Temperature Sensors			
		Basic Room Sensor	Cool to Warm Adjust	Digitally Adjustable Display Sensor	
					
		Temperature Sensing, LED Status Indication, Override/Reset Button	Cool/Warm Temperature Sensing Adjustment, LED Status Indication, Override/Reset Button	Temperature, Occupancy, Alarm, Setpoint and Status display, Override/Reset and Occupied/Unoccupied Buttons	Temperature, Humidity, Occupancy, Alarm, Setpoint and Status display, Override/Reset and Occupied/Unoccupied Buttons
Daikin Part Number		910152149	910171464	910152147	910121754
Feature					
Setpoint Adjustment		None	Cool to Warm	Digitally Adjustable	Digitally Adjustable
Display	Room Temperature & Setpoint			•	•
	Room Humidity & Setpoint				•
Stages	Heating	4	4	4	4
	Cooling	3	3	3	3
Operating Modes	System				Heat-Off-Cool-Auto Dehumidify
	Fan				On-Auto
	Occupancy			LCD Display of Occupied-Unoccupied Icon	LCD Display of Occupied-Unoccupied Icon
Annunciation	Status LED	•	•	LCD Display of Unit Status	LCD Display of Unit Status
	LCD Alarm Display			•	•
Reset	Alarm	•	•	•	•
	Setback Override	•	•	•	•
Application					
Dehumidification	Smart Dehumidification				•
Electric Heat	Boilerless	•	•	•	•
	Supplemental	•	•	•	•
	Primary	•	•	•	•
Waterside Economizer		•	•	•	•
Hydronic Heat		•	•	•	•

General

Contractor shall furnish and install Water Source Heat Pumps as indicated on plans. Each unit shall be CETL Listed. Units less than 135,000 Btu/hr. total cooling capacity shall be ISO rated per Standard 13256-1. Each unit shall be fully run tested at the factory. Each unit shall be shipped on a wooden skid and covered with plastic.

Casing and cabinet

The casing shall be constructed of heavy-gauge G-60 galvanized steel corner posts and steel panel construction with heavy gauge steel base pan. The base pan shall have holes to accept field installation of rubber or spring isolators. The interior shall be lined with 1/2" thick, 1½ lb. density glass fiber. Multiple panels on front, back and sides shall provide access to compressor, control box, fan motor and fan assembly. Unit shall have a galvanized steel painted drain pan with a drain connection extending through the unit casing. Insulated drain pan shall act as a divider panel between the compressor and fan sections. Units shall have as standard a factory installed 2" thick filter brackets for side filter removal. Unit shall have multiple 2" thick throwaway filters. Cabinets shall have knockouts for entrance of line voltage and low voltage control wiring. Supply return water and condensate connections shall be copper FPT fittings and protrude through the casing.

R-410A refrigerant circuit

Units shall be dual circuit design containing scroll compressors, electronic expansion valve, water-to-refrigerant braze plate heat exchanger, reversing valve, finned tube heat exchanger (air coil), and safety controls. Non-ozone depleting R-410A refrigerant must be used. Compressor(s) shall be scroll type with thermal overload protection and external rubber vibration isolation mounts. Air coil shall be aluminum fins bonded to copper tubes. The coaxial heat exchanger shall be copper inner tube and steel outer tube with a U.L. listing and a 500 psig water side rating and a 600 psig refrigerant side rating. Optional Cupro-nickel coax coil/steel outer tube is available for geothermal units. High and low side service valves shall be provided on each refrigerant circuit for measuring and charging of the refrigerant circuit. Safety controls shall include a low suction temperature (freezestat), high refrigerant pressure and low refrigerant pressure switches. Units shall be capable of being reset only by interrupting the power supply to the unit and not from the wall thermostat. Unit shall be capable of starting in an ambient of 40° F with entering water at 55° F standard range, 20° F geothermal range, with both air and water flow rates at the ISO rating conditions.

Hot gas bypass

The optional factory-installed hot gas bypass option shall limit the minimum suction pressure during cooling operation to protect the air coil from freezing.

Electrical

A control enclosure shall be located within the unit and shall contain controls for compressor(s), reversing valves(s) and fan motor operation. A terminal block shall facilitate main power wiring connection. A 75 VA transformer shall supply the low voltage control circuit. Unit shall be nameplated to accept time delay fuses for branch over-current protection of the power conductors. Unit control system shall provide one or two stage cooling and heating as required by the setpoints of the wall thermostat. The unit shall be capable of providing an output signal to a unit-mounted LED annunciator to indicate a "fault" condition.

The control system shall be microprocessor based and provide the following:

- Stand-alone operation
- LONWORKS communication capabilities (Must be LON-MARK 3.4 certified)
- BACnet communication capabilities (BACnet MS/TP Network)

Fan and motor assembly

Units shall have a belt driven centrifugal fan. A high efficiency TEFC blower motor shall be provided on 72,000 BTUH through 120,000 BTUH units. Factory adjustable sheaves shall be set for optimum fan performance. Field adjustment of sheaves and belt tension shall be required for airflow balancing. The fan housing shall protrude through the cabinet to facilitate field duct connection. (Option):Unit shall have a Variable Frequency Drive (VFD) capable of soft start and programmable for air balance, controlled by an external signal by others.

Filter rack and filters

Unit shall come standard with a 2-inch disposable filter and a 2-inch 2-sided factory-installed combination filter rack. The filters shall be removable from either side of the unit.

As selectable options, unit shall have a 2-inch thick MERV 8 or 4 inch MERV 13 filter, factory-installed with a 2-inch or 4-inch factory-installed filter rack.

As factory installed options, units shall be available with no filter and filter rack, or no filter.

Solid-state control system

MicroTech III control system - Unit shall have a microprocessor- based control system. The unit control logic shall provide heating and cooling operation as required by the wall thermostat set point. The control system shall provide the following for stand-alone operation:

1. The use of standard non-programmable or programmable wall thermostats.
2. Fan operation simultaneous with the compressor (fan interlock) regardless of thermostat logic.
3. Anti-short cycle time delay for compressor operation.
4. Random start up on power up mode.
5. Single grounded connection to the "E" terminal will place the unit in the remote shutdown mode.
6. Ground signal to the "U" terminal will put the unit in night setback mode.
7. Night setback override function is available with the MicroTech III control system. The thermostat must have an override feature/capability.
8. Brownout protection to suspend unit operation if the supply voltage drops below 80% of normal. This is low voltage protection.
9. Condensate overflow protection to suspend cooling operation or dehumidification, in an event of a full drain pan.
10. Unit protection during high or low refrigerant pressure conditions.
11. Water coil low temperature protection.
12. Method of defeating compressor, time delays for fast service diagnostics.
13. Option to reset unit at thermostat (remote reset) - Provides means to remotely reset automatic lock-outs generated by high/low pressure faults and/or low temperature faults.
14. Intelligent alarm reset - clears re-settable faults the 1st two times they occur within a 24-hour period and triggers automatic lock-out on 3rd fault.
15. Freeze fault protection is based on the leaving water temperature (LWT) input, and is used to help protect the unit from excessively low water and air coil temperature.
16. 24V output to cycle a motorized water valve when water flow is required
17. The low-pressure switch condition may exist for 30 seconds at compressor start up to avoid nuisance low pressure trips.
18. Light emitting diode (LED) for the MicroTech III and I/O expansion control boards indicate high pressure, low pressure, low voltage, low water/air temperature

cut out, condensate overflow, and freeze fault.

19. Optional phase monitor shall monitor quality of all phases of supplied power and if irregularity is detected unit shall be disabled.

MicroTech® III control with I/O expansion module

– I/O Expansion Module connects directly to the main MicroTech III controller to provide control of the second refrigeration circuit. The I/O module provides a 24v output for control of a field installed electric heater.

MicroTech III control with LONWORKS® communication module

– Unit shall have a microprocessor-based control system. The unit control logic shall communicate over a LONMARK communications network. The unit controller is factory programmed [LONMARK ® 3.4 certified Application Code the current standard for new applications] and tested with all the logic required to monitor and control heating and cooling operation. The controller sets the unit mode of operation, monitors water and air temperatures, and can communicate fault conditions via a LONMARK communications network. Units with the MicroTech III and LONWORKS communication module include return air, discharge air and leaving water temperature sensors. Space temperature sensor options include a set-point adjustment, tenant override button, and the capability of substituting the return air sensor with a wall-mounted room sensor.

Microtech III control w/ BACnet® communication

Module – Unit shall have a microprocessor-based control system. The unit control logic shall communicate over a BACnet communications network. The BACnet communication module shall incorporate an Atmel ARM7 Thumb series MCU and be capable of supporting a full MSTP BACnet implementation. The microprocessor shall also support SPI compatible communications with the MCU of the Microtech III controller. The physical interface to a BACnet BAS network shall be through an industry standard RS-485 transceiver capable of existing on an RS-485 network of up to 64 nodes. The unit controller is factory programmed and tested with all the logic required to monitor and control heating and cooling operation. The controller sets the unit mode of operation, monitors water and air temperatures, and can communicate fault conditions via a BACnet communications network. Units outfitted with Microtech III and BACnet Communication modules include return air, discharge air and leaving water temperature sensors. Space temperature sensor options include a set-point adjustment, tenant override button, and the capability of substituting the return air sensor with a wall-mounted room temperature sensor.

Each communicating unit controller performs the following unit operations:

- Enable heating and cooling to maintain space temperature set point at the room sensor
- Enable fan and compressor operation
- Monitor all safety controls
- Monitor discharge and return air temperature
- Monitor leaving water temperature
- Relay status of all vital unit functions
- Support optional control outputs

Unit mounted LED annunciators aid in diagnosing unit operation by indicating the water source heat pump operating mode and alarm conditions. If there are no current alarm conditions, a green LED on the annunciator board will indicate normal unit operating mode. If an alarm condition exists, the Microtech III controller will send the fault condition to the LED annunciator, which will assist in troubleshooting the unit. LED Annunciator shall be visible without removing access panel. Heat pumps with the MicroTech III Controller with a LONWORKS Communication Module is designed to be linked with a centralized Building Automation System (BAS) through a LONMARK communications network for centralized scheduling and management of multiple heat pumps.

Warranty

- An optional 1-year extended compressor warranty covers the compressor for 2 years from the date at which the unit ships from the factory.
- An optional 1-year extended refrigeration circuit warranty covers the entire refrigeration circuit and related components for 2 years
- An optional 1-year extended complete parts warranty covers all parts components for 2 years.
- An optional 4-year extended compressor warranty covers the compressor for 5 years from the date at which the unit ships from the factory.
- An optional 4-year extended refrigeration circuit warranty covers the entire refrigeration circuit and related components for 5 years
- An optional 4-year extended complete parts warranty covers all parts components for 5 years.

In addition to the above warranties an optional 1st year labor allowance is available.

Field installed accessories

Wall mounted thermostats

- Programmable Electronic Thermostat Two-stage heat/Two-stage cool, 7-day programmable. Subbase shall have system "Mode/Prog" and fan "Auto/On" switches. Thermostat shall have the option of an Optional Remote Sensor.
- Non-programmable, auto or manual changeover Two-stage heat/Two-stage cool, night setback override. Subbase shall have system "Cool/Off/Heat/Auto" and fan "Auto/On switches. Thermostat shall have the option of an Optional Remote Sensor.
- Programmable Touch Screen Thermostat, offers precise temperature and humidity sensing and control. When combined with a multiple-stage heat pump and electric heat control this thermostat provides the ultimate in thermostatic control with a +/- 1°F accuracy.

Wall mounted room temperature sensors for BACnet and LONWORKS communications:

- Wall Sensor with timed-override button.
- Wall Sensor with timed-override button and set point adjustment (55 to 95 deg F), fan mode switch (auto/on), operational mode button (Heat/Cool/Auto) and status LED to display fault condition.
- Wall Sensor with timed-override button and set point adjustment (-3 to +3 deg F), fan mode switch (auto/on), operational mode button (Heat/Cool/Auto) and status LED to display fault condition.
- Wall Sensor with timed-override button and set point adjustment (-5°F to + 5°F), fan mode switch (auto/on), operational mode button (Heat/Cool/Auto) and status LED to display fault condition.

Humidistat

- To be used in conjunction with one of the dehumidification options. Humidistat to be wall mounted and capable of providing solid state input to unit controls to enable/disable dehumidification features.

Hose kits:

Hose kits with standard flexible supply and return hoses are recommended between the water source heat pump unit and building's hard piping system. This is to control possible noise and transmission of vibration from the unit in the space.

Standard supply and return fire-rated hoses have Thermoplastic Rubber (EPTF) with braided covering of stainless steel. The supply and return hoses have a swivel fitting at one end to facilitate removal of the unit for replacement or service. Fittings are either plated steel or brass. The maximum working pressure for both the shut-off ball valve and shut-off ball valve with strainer is 400 psig. The maximum operating temperature is -4°F (-20°C) to 250°F (121°C).

A summary of various hose kits are listed below. See Catalog 1196 for more detailed hose kit features.

Hose kit # 1: Condensate hose kits – one flexible fire rated condensate hose with fixed male NPT x female JIC swivel with male NPT adapter.

Hose kit # 2: Supply and return hose kits – two flexible supply and return hoses with fixed male NPT x female JIC swivel with male NPT adapter.

Hose kit # 4: Supply and return hose kits with shut-off ball valves - valves have pressure and temperature (P/T) ports to allow pressure and temperature readings during commissioning.

Hose kit # 5: Supply and return hose kits with shut-off ball valves, Y-strainer and blowdown valve – the supply hose assembly includes a shut-off ball valve with one pressure/temperature test port, Y-strainer with blowdown valve. The return assembly includes a shut-off ball valve with pressure/temperature test port and drain valve for servicing.

Hose kit # 6: Supply and return hose kits with ball valve and autoflow control valve – the supply hose assembly includes a shut-off ball valve with one pressure/temperature test port. The return assembly includes a shut-off ball valve with two pressure/temperature test ports and autoflow control valve.

Hose kit # 7: Supply and return hose kits with ball valve and autoflow control valve, Y-strainer and blowdown valve – the supply hose assembly includes a shut-off ball valve with one pressure/temperature test port Y-strainer with blowdown valve. The return assembly includes a shut-off ball valve with two pressure/temperature test ports and autoflow control valve.

Valve options:

- Combination water balancing and shutoff valve with adjustable memory stop.
- Optional 2-way, Normally Open (N.O.) or Normally Closed (N.C.) motorized water valves.



Daikin Applied Training and Development

Now that you have made an investment in modern, efficient Daikin equipment, its care should be a high priority. For training information on all Daikin HVAC products, please visit us at www.DaikinApplied.com and click on Training, or call 540-248-9646 and ask for the Training Department.

Warranty

All Daikin equipment is sold pursuant to its standard terms and conditions of sale, including Limited Product Warranty. Consult your local Daikin Applied representative for warranty details. Refer to Form 933-430285Y. To find your local Daikin Applied representative, go to www.DaikinApplied.com.

Aftermarket Services

To find your local parts office, visit www.DaikinApplied.com or call 800-37PARTS (800-377-2787). To find your local service office, visit www.DaikinApplied.com or call 800-432-1342.

This document contains the most current product information as of this printing. For the most up-to-date product information, please go to www.DaikinApplied.com.

Products manufactured in an ISO Certified Facility.