



Catalog 635-3

**Trailblazer®
Air-Cooled Scroll Compressor Chillers
With High Efficiency Variable Speed Fan Technology**

**Model AGZ-F
030 to 230 Tons (105 to 809 kW)
R-32 Refrigerant
60/50 Hz**

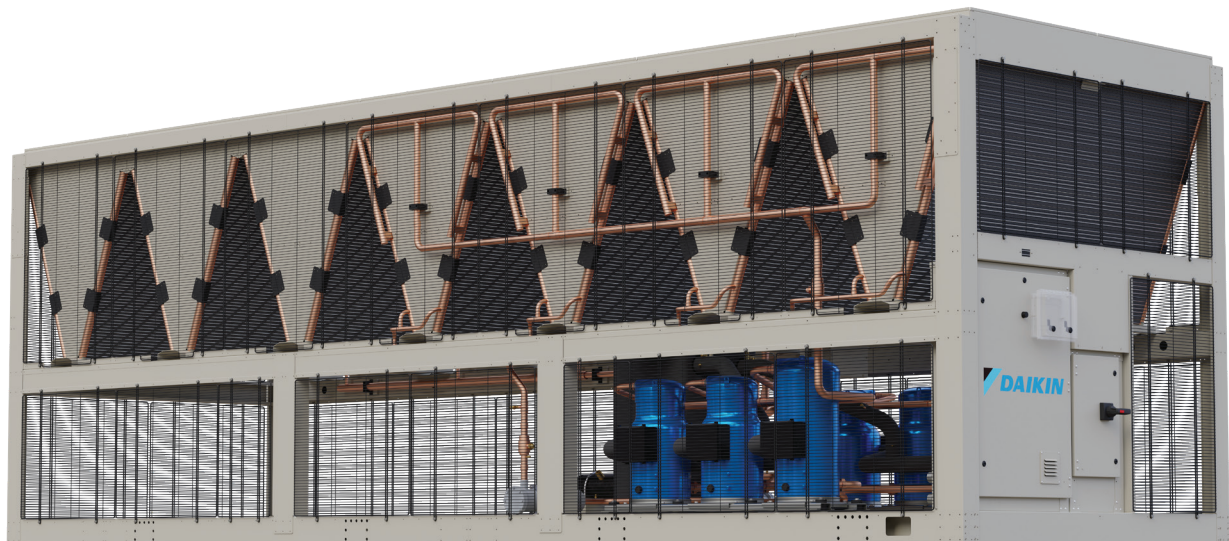

Table of Contents

Introduction	3
Features and Benefits	4
Nomenclature	4
Unit Design Features	4
Application Considerations	7
Operating and Standby Limits	7
Unit Placement	7
Service Clearance	7
Operational Spacing Requirements	7
Chilled Water Piping	7
Inlet Strainer Guidelines	8
Water Flow Limitations	9
System Water Volume Considerations	9
Evaporator Freeze Protection	9
Condenser Coils	10
Epoxy coil coating	10
Water Flow Switch	11
Electronic Expansion Valve	11
Options and Accessories	12
Electrical Options and Accessories	12
Unit Options and Accessories	13
Engineering Specifications	14
Limited Warranty	18

Manufactured in an ISO 9001 & ISO 14001 certified facility



©2024 Daikin Applied, Minneapolis, MN. All rights reserved throughout the world. This document contains the most current product information as of this printing. Daikin Applied Americas Inc. has the right to change the information, design, and construction of the product represented within the document without prior notice. For the most up-to-date product information, please go to www.DaikinApplied.com.™® Trailblazer, SiteLine, MicroTech, RapidRestore, and Daikin Applied are trademarks or registered trademarks of Daikin Applied Americas Inc. The following are trademarks or registered trademarks of their respective companies: BACnet from American Society of Heating, Refrigerating and Air-Conditioning Engineers, Inc.; Echelon, LonWorks, LonMark, and LonTalk from Echelon Corporation; Modbus from Schneider Electric; and Windows from Microsoft Corporation..

Introduction

The Trailblazer® family of air-cooled scroll chillers continues the Daikin Applied legacy of high quality, high efficiency, latest technology and quiet operation. These features make the Trailblazer family the best overall value in air-cooled packaged chillers available today.

Air-Cooled Chiller Products

Trailblazer® Air-to-Water Scroll Heat Pump
EWYQ/EWYT • 25 RT

Trailblazer® Air-Cooled Scroll Compressor Chiller
AGZ-F • 30 - 230 RT
High-efficiency, remote evaporator, and pump package options available

Pathfinder® Air-Cooled Screw Compressor Chiller
AWV VFD • 100 - 565 RT
*100% configurable with Variable Volume Ratio (VVR) technology
Remote evaporator, pump package, and integrated water-side economizer options available*

SITESLINE
DAIKIN BUILDING CONTROLS

2021 AWARD WINNER

Efficient Operation

The Trailblazer units utilize environmentally acceptable R-32 refrigerant and meet the performance requirements of ASHRAE Standard 90.1 for efficiency. Excellent part-load performance is achieved with four or six scroll compressors. A variable speed condenser fan option is also available to provide even higher part load efficiency. High overall efficiency = lower annual energy costs.

RapidRestore® and Fast Loading

When power has been interrupted, the Trailblazer has the capability to restore cooling quickly by using RapidRestore and Fast Loading. These options make Trailblazer ideal for mission critical buildings, data centers, healthcare facilities, and manufacturing processes. Once power is restored after a power loss, the chiller will load approximately four times faster with RapidRestore than during normal operation.

Quiet Operation

The Trailblazer units live up to the Daikin Applied reputation for low operating sound levels and make these chillers “neighborhood friendly.” Full load sound pressure levels as low as 60 dB without insulation.

LEED® Points

For building owners who wish to pursue Leadership in Energy and Environmental Design (LEED®) Green Building Certification, points earned for Optimize Energy Performance (formerly EA Credit 1) are awarded based on overall building efficiency. The high efficiency of the AGZ-F will contribute to the total points earned for this credit. Trailblazer chillers can also contribute to Enhanced Refrigerant Management (formerly EA Credit 4) qualification which is partially determined by tonnage and refrigerant quantity. Consult with your Daikin Applied sales representative for more information.

Features and Benefits

Nomenclature

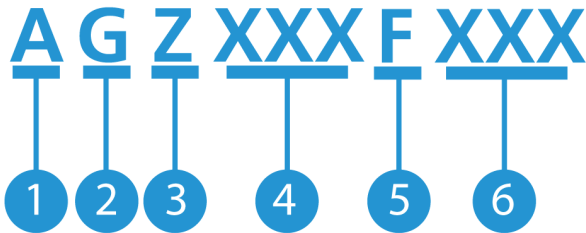

No.	Description
1	A = Air-Cooled
2	G = Global
3	Z = Scroll Compressor
4	Number of Fans
5	Design Vintage
6	Compressor Code

Unit Design Features

Daikin Trailblazer air-cooled chillers are a product of our commitment to offer quiet, reliable, energy efficient equipment, incorporating high quality compressors, and innovative packaging.

Construction

Trailblazer chillers are factory-assembled and mounted on a heavy-gauge steel base. The base distributes the unit weight for roof loading. Their small footprint allows smaller mounting pads or support structures and is a plus for retrofit or replacement applications.

Protective Coil and Base Guards

Factory-installed wire grille guards surround the coils and base to provide protection for ground-level installations as standard.

Compressors

Reliable hermetic scroll compressors with cast iron scrolls and three Teflon® impregnated bearings are used on the Trailblazer chillers to promote longevity.

Each model has the ability to modulate its capacity. Models with four compressors will have four steps of capacity modulation while models with six compressors will have six steps. Compressors stage on depending on the load of the system. This results in excellent part-load efficiency and reduced annual operating costs.

Figure 1: Scroll Compressors

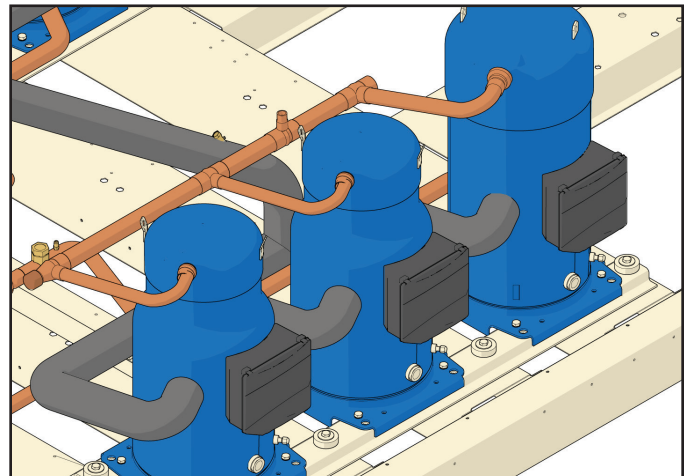

Evaporator

Trailblazer units are designed to maximize efficiency in the smallest possible footprint. The evaporator is a compact, high efficiency, dual circuit, brazed plate-to-plate type heat exchanger consisting of parallel stainless steel plates. These heat exchangers provide excellent heat exchange efficiency in a compact footprint and are especially attractive for smaller capacity units. Evaporators are designed and constructed according to, and listed by, Underwriters Laboratories (UL).

Figure 2: Brazed-Plate Evaporator

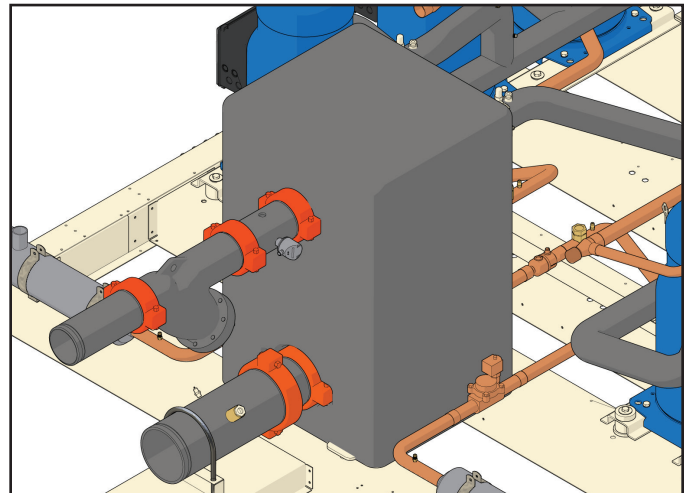

Condenser Coils

Condenser coils are all aluminum alloy microchannel design with a series of flat tubes containing multiple, parallel flow microchannels layered between the refrigerant manifold piping. See “Condenser Coils” on page 10 for discussion of environmental factors related to material and coating options.

Figure 3: Microchannel Coil

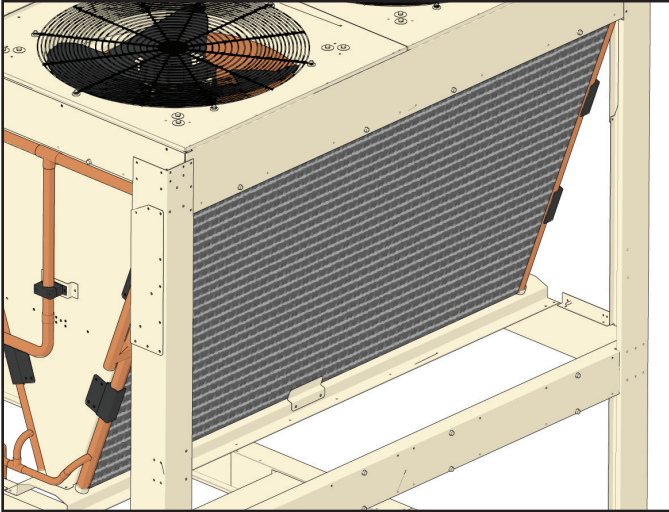

Optional High Efficiency Variable Speed Condenser Fans

The MicroTech® chiller controller uses ECM fan technology with an integrated inverter to optimize chiller efficiency and maintain proper head pressure. This feature improves part load efficiency substantially and offers the ability to operate in low ambient conditions down to -4°F.

All High Efficiency Trailblazer models also include a sound reduction mode to allow for reduced-sound operation.

Figure 4: High Efficiency Variable Speed Condenser Fans

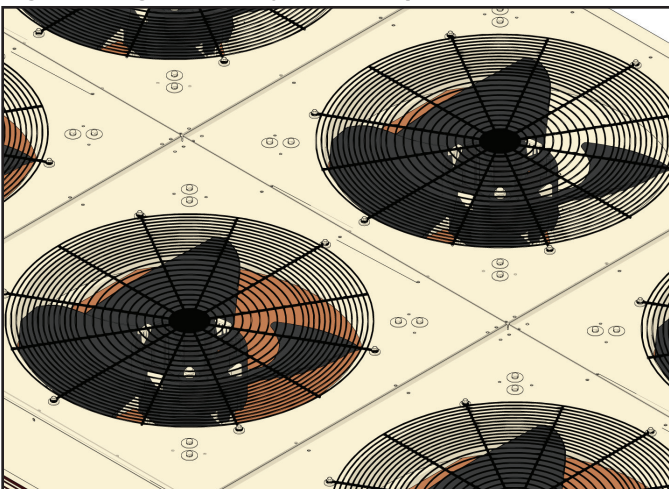

Control System

The MicroTech advanced chiller controller surpasses all other microprocessor-based chiller control systems available today. This powerful, user-friendly control system provides the flexibility and performance needed for either stand-alone unit operation or the controller can be easily tied into the building automation system of choice using the Daikin open protocol feature.

Figure 5: MicroTech Unit Controller

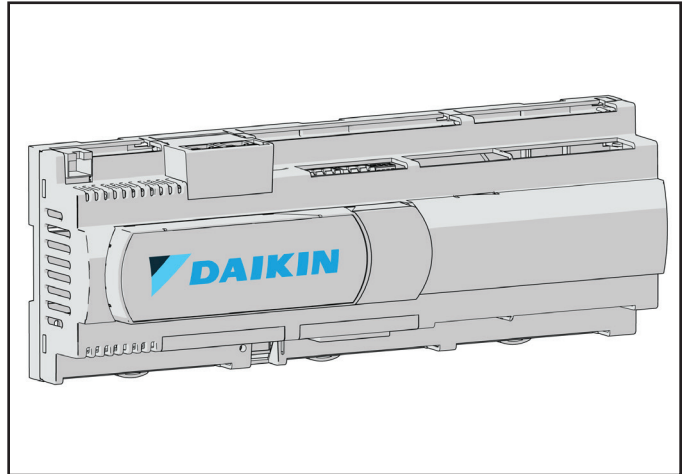

The open protocol platform allows you to choose from open standard protocols, such as BACnet® and Modbus® to communicate easily with the building automation system that best meets the facility requirements. These optional communications modules are available factory installed or can be easily field installed.

The MicroTech controller’s design will not only permit the chiller to run more efficiently, but will also simplify troubleshooting if a system failure occurs. Every MicroTech® chiller controller is programmed and tested prior to shipment to help provide a trouble-free start-up.

Replaceable Core Filter Drier

Factory-installed filter drier with a replaceable core allows for fast replacement of filter element and easier serviceability.

Optional Remote Evaporators

Units with the optional remote evaporator will have the evaporator shipped separately for field mounting and piping to the outdoor unit.

Optional Pump Package

The on-board, integrated chilled water pump package provides important benefits:

- Simplifies the chilled water system design and installation
- Provides installation savings by reducing field piping, wiring and control costs
- Saves valuable floor space inside the building.
- Reduces project engineering content
- Greatly reduces pump operating costs with the variable flow pump VFD

Figure 6: Optional Pumps Package Components

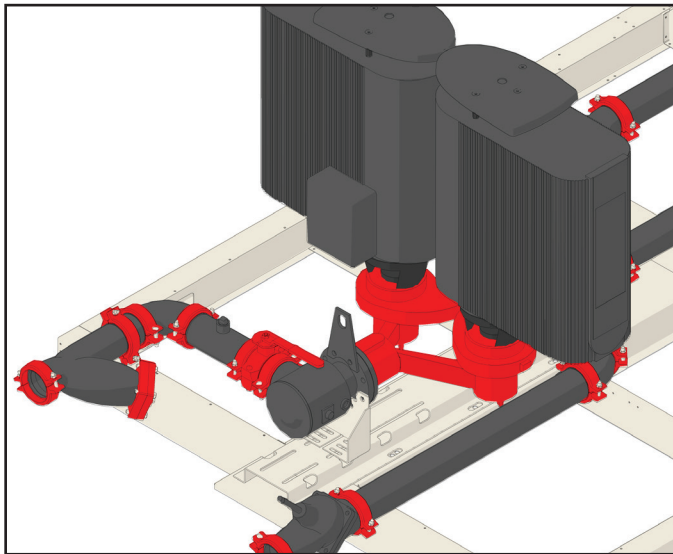

Standard Components

Single Pump: Single spring inside seal, vertical, in-line, radially split-case pump, serviceable without breaking pipe connections. The motor and pump rotating assembly can be serviced without removing the pump casing from the line.

Dual Pumps in a Single Casting: Single spring inside-seal vertical, in-line, radially split-case pumps, mounted in a common casing with a common inlet connection and outlet connection and including a flapper valve to prevent recirculation when only one pump is operating. The pumps are designed for duty/standby, not parallel operation. All information and performance curves for the single pump arrangement (Model 4380) can be used for the dual pump arrangement (Model 4372 and 4362).

The package is also equipped with:

- “Y” type inlet strainer
- combination triple-duty outlet valve containing:
 - discharge shutoff valve
 - check valve
 - flow throttling valve
- combination suction guide with flow stabilizing outlet vanes and stainless steel strainer with a disposable fine-mesh start-up strainer
- mounted and wired flow switch
- factory power and control wiring
- interconnecting piping and insulation of all cold surfaces

Various tank and connection options are available for field mounting. Refer to the schematic in [Figure 6](#) for more information.

Variable Flow VFD

The operating cost savings resulting from using variable chilled water flow via a pump VFD is well known. In the past, however, its usage has been somewhat limited by the cost and uncertainty of field installing the required system pressure differential sensors.

Daikin Applied can now offer flow control through the pump VFD without the need for external pressure sensors. In addition to the sensorless operation, there are three other selectable operating modes:

BAS Input: The pump speed and system flow will be controlled from a customer-supplied BAS input signal.

Remote Sensor Control: The VFD is wired to a pressure sensor mounted in the chilled water piping system. This is the standard VFD control when a sensorless VFD is not used.

Locally Selected Constant Speed Control: Provides manual control of the pump speed, overriding any current automatic speed control.

Consult the current version of the installation manual for additional detailed information, which is available from your local Daikin Applied sales office or on www.DaikinApplied.com.

Application Considerations

Operating and Standby Limits

Table 1: Operating Limits

Maximum standby ambient temperature	130°F (54°C)
Maximum operating ambient temperature	105°F (41°C)
-with optional high ambient package	125°F (52°C)
Minimum operating ambient temperature (standard control)	32°F (0°C)
-with optional low ambient control (see "Low Ambient Operation" on page 10)	-4°F (-20°C)
Leaving chilled water temperature	40°F to 65°F (4°C to 18°C)
Leaving chilled fluid temperatures (with anti-freeze) - Note that in cases of high ambient temperature, the lowest leaving water temperature settings may be outside of the chiller operating envelope; consult Daikin Tools® to ensure chiller is capable of the required lift.	15°F to 65°F (-9°C to 18°C)
Operating chilled water delta-T range	6°F to 20°F (3.3°C to -6.6°C)
Maximum evaporator operating inlet fluid temperature	81°F (27°C)
Maximum evaporator non-operating inlet fluid temperature	100°F (38°C)

Unit Placement

Trailblazer units are for outdoor applications and can be mounted either on a roof or at ground level. For roof mounted applications, install the unit on a steel channel or I-beam frame to support the unit above the roof. For ground level applications, install the unit on a substantial base that will not settle. Use a one-piece concrete slab with footings extended below the frost line. Be sure the foundation is level within 0.5" (13 mm) over its length and width. The foundation must be strong enough to support the unit weight.

Service Clearance

Figure 7: Service Clearance

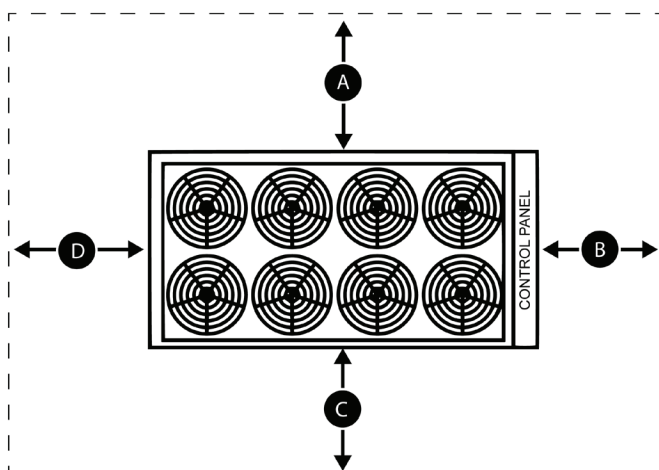

Table 2: Service Clearance

Side	Minimum Clearance	Notes
A	8 ft (2.4 m)	Sides: It is highly recommended to provide a minimum of 8 feet (2.4 meters) on one side to allow for coil replacement. A minimum of 4 feet (1.2 meters) of side clearance is required; however, the unit performance may be derated.
B	4 ft (1.2 m)	Control Panel Side: Minimum of 4 feet (1.2 meters)
C	4 ft (1.2 m) if all other requirements are met	Sides: It is highly recommended to provide a minimum of 8 feet (2.4 meters) on one side to allow for coil replacement. A minimum of 4 feet (1.2 meters) of side clearance is required; however, the unit performance may be derated.
D	4 ft (1.2 m)	Opposite Control Panel End: Minimum of 4 feet (1.2 meters)

Operational Spacing Requirements

Sufficient clearance must be maintained between the unit and adjacent walls or other units to allow the required unit air flow to reach the coils. Failure to do so will result in a capacity reduction and an increase in power consumption. No obstructions are allowed above the unit at any height. The clearance requirements shown are a general guideline and cannot account for all scenarios. Such factors as prevailing winds, additional equipment within the space, design outdoor air temperature, and numerous other factors may require more clearance than what is shown. Additional clearances may be required under certain circumstances.

Chilled Water Piping

All evaporators and condensers have OGS-type grooved water connections (adhering to Standard AWWA C606). The installing contractor must provide matching mechanical connections. Be sure that water inlet and outlet connections match certified drawings and nozzle markings.

NOTICE
PVC piping should not be used.

WARNING
Polyolester Oil, commonly known as POE oil is a synthetic oil used in many refrigeration systems, and is present in this Daikin product. POE oil, if ever in contact with PVC/CPVC, will coat the inside wall of PVC/CPVC pipe causing environmental stress fractures. Although there is no PVC/CPVC piping in this product, please keep this in mind when selecting piping materials for your application, as system failure and property damage could result. Refer to the pipe manufacturer's recommendations to determine suitable applications of the pipe.

CAUTION

To prevent damage to the evaporator and potential chiller failure, a supply strainer is required in the inlet water piping which connects to this evaporator. This strainer must be installed prior to operation of the chilled liquid pumps.

Field installed water piping to the chiller **must** include:

- A cleanable strainer installed at the water inlet to the evaporator to remove debris and impurities before they reach the evaporator. Install cleanable strainer within 5 feet (1500 mm) of pipe length from the evaporator inlet connection and downstream of any welded connections (no welded connections between strainer and evaporator).
- Adequate piping support to eliminate weight and strain on the fittings and connections.
- A water flow switch must be installed in the horizontal piping of the supply (evaporator inlet) water line to avoid evaporator freeze-up under low or no flow conditions. The flow switch is supplied by the factory as an installed component or a field-installed kit shipped along with the unit. (See page 11 for more information.)

NOTICE

Units with the optional pump package include the strainer and flow switch.

- Piping for units with brazed-plate evaporators must have a drain and vent connection provided in the bottom of the lower connection pipe and to the top of the upper connection pipe respectively, see Figure 8. These evaporators do not have drain or vent connections due to their construction.
- Water pressure gauge connection taps and gauges at the inlet and outlet connections of the evaporator for measuring water pressure drop.

It is **recommended** that the field-installed water piping to the chiller include:

- Thermometers at the inlet and outlet connections of the evaporator.
- Vibration eliminators in both the supply and return water lines.
- Insulated chilled water piping to reduce heat loss and prevent condensation. For information on freeze protection, see “Evaporator Insulation” on page 13.
- Isolation valves installed in the incoming and outgoing water piping to the evaporator.

NOTICE

Failure to follow these measures may result in performance and reliability issues.

Figure 8: Typical Piping, Brazed-Plate Evaporator

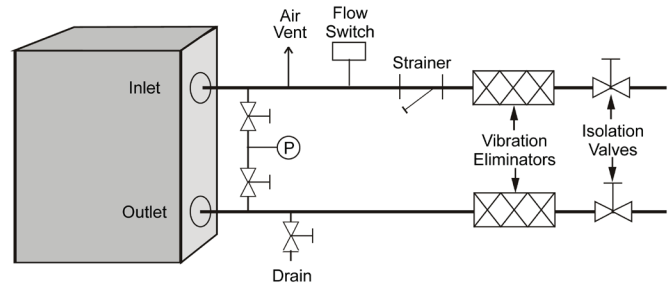

NOTICE

Welded pipe connections are not allowed between the strainer and evaporator due to the chance of slag entering the evaporator. Evaporator may be oriented with connections on a different side than shown.

Inlet Strainer Guidelines

An inlet water strainer kit **must** be installed in the chilled water piping before the evaporator inlet. Several paths are available to meet this requirement:

1. A factory installed option.
2. A field-installed kit shipped-loose with the unit that consists of:
 - Y-type area strainer with 304 stainless steel perforated basket, Victaulic pipe connections and strainer cap.
 - Extension pipe with two Schrader fittings that can be used for a pressure gauge and thermal dispersion flow switch. The pipe provides sufficient clearance from the evaporator for strainer basket removal.
 - 0.5-inch blowdown valve
 - Two grooved clamps
3. A field-supplied strainer that meets specification and installation requirements of the current Installation, Operation and Maintenance Manual available at www.DaikinApplied.com.

Both are sized and with the pressure drop shown in Figure 9.

Figure 9: Strainer Pressure Drop

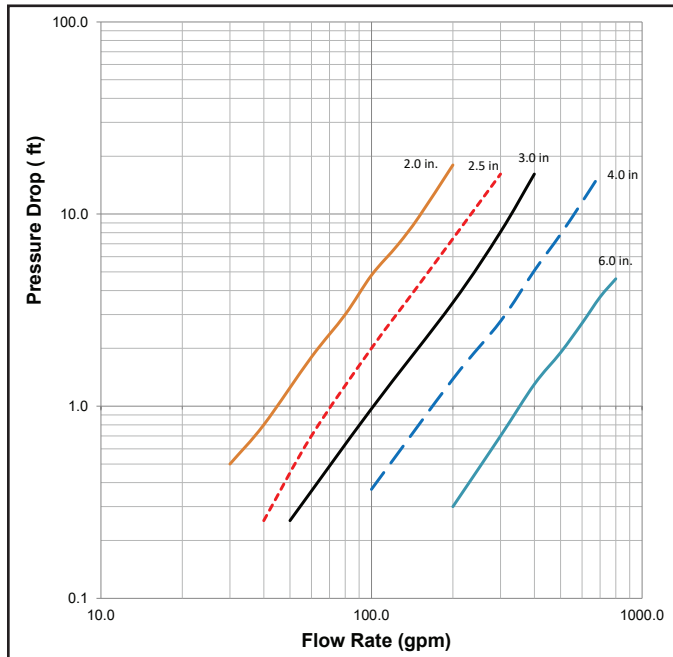
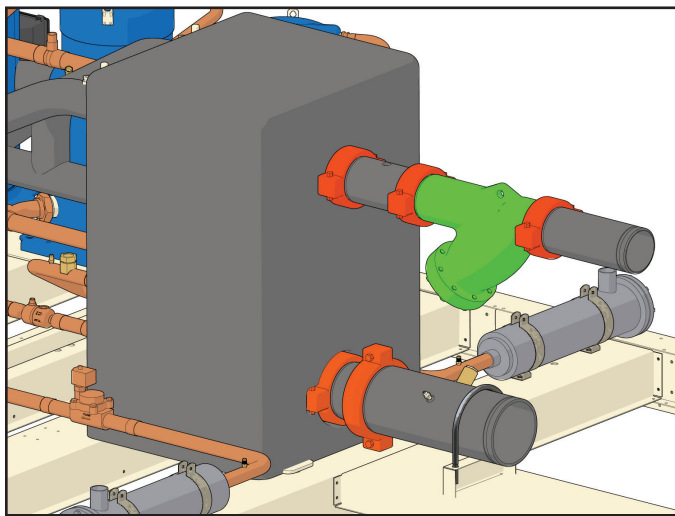

Figure 10: Factory Installed Strainer



Water Flow Limitations

Constant Flow

The evaporator flow rates and pressure drops shown in Figure 9 are for full load design purposes. The maximum flow rate and pressure drop is based on a 6°F temperature drop. Flow rates above the maximum values will result in unacceptable temperature and pressure drops and can cause excessive erosion, potentially leading to failure.

The minimum flow and pressure drop is based on a full load evaporator temperature drop of 16°F. Evaporator flow rates below the minimum values can result in laminar flow causing freeze-up problems, scaling and poor control.

Variable Flow

Reducing evaporator flow in proportion to load can reduce system power consumption. The rate of flow change should be a maximum of 10 percent of the flow per minute. For example, if the maximum design flow is 200 gpm and it will be reduced to a flow of 140 gpm, the change in flow is 60 gpm. Ten percent of 200 gpm equals 20 gpm change per minute, or a minimum of three minutes to go from maximum to desired flow. The water flow through the evaporator must remain between the minimum and maximum values. If flow drops below the minimum allowable, large reductions in heat transfer can occur. If the flow exceeds the maximum rate, excessive pressure drop and tube erosion can occur.

System Water Volume Considerations

All chilled water systems need adequate time to recognize a load change, respond to the change and stabilize to avoid undesirable short cycling of the compressors or loss of temperature control. In air conditioning systems, the potential for short cycling usually exists when the building load falls below the minimum chiller plant capacity or on close-coupled systems with very small water volumes. Some of the things the designer should consider when looking at water volume are the minimum cooling load, the minimum chiller plant capacity during the low load period and the desired cycle time for the compressors. Assuming that there are no sudden load changes and that the chiller plant has reasonable turndown, a rule of thumb of “gallons of water volume equal to two to three times the chilled water gpm flow rate” is often used. A storage tank may have to be added to the system to reach the recommended system volume.

Evaporator Freeze Protection

Evaporator freeze-up can be a concern in the application of air-cooled water chillers in areas experiencing below freezing temperatures. To protect against freeze-up, insulation and an electric heater are furnished with the evaporator. AGZ-F chillers have an external plate heater and thermostat that helps protect the evaporator down to -20°F (-29°C) ambient air temperature. Although the evaporator is equipped with freeze protection, it does not protect water piping external to the unit or the evaporator itself if there is a power failure or heater burnout, or if the chiller does not directly control the chilled water pumps. Use one of the following recommendations for additional protection:

1. If the unit will not be operated during the winter, drain evaporator and chilled water piping and flush with glycol.
2. Add a year-round glycol solution to the chilled water system to provide freeze protection. Freeze point should be approximately 10°F (5.6°C) below minimum design ambient temperature or 10°F below the lowest design leaving water temperature, whichever is lower. The use of glycol anti-freeze is generally considered the safest

protection against freeze-up, however, it will reduce the performance of the unit, depending the concentration. Take this into consideration during initial system design and selection. On glycol applications, a minimum fluid concentration should be based on Burst Protection limits.

3. The field installation of thermostatically controlled heat tracing and insulation to exposed piping. Factory insulation will have to be removed and replaced after installation of the tracing.
4. Continuous circulation of water through the chilled water piping and evaporator. (Dependent on power availability).

The evaporator heater cable or immersion heater is factory wired to the 115 volt circuit in the control box. This power should be supplied from a separate source to maximize unit protection, but it can be supplied from the control circuit. Operation of the heaters is automatic through the ambient sensing thermostat that energizes the evaporator heaters for protection against freezing. Unless the evaporator is drained in the winter or contains an adequate concentration of anti-freeze, the disconnect switch to the evaporator heater must be closed. Conversely, do not apply heat to the evaporator if it is drained.

High Ambient Operation

Trailblazer units for high ambient operation (104°F to 125°F, 40°C to 52°C) require the addition of the optional high ambient package.

Low Ambient Operation

Compressor staging is adaptively determined by system load, ambient air temperature, and other inputs to the MicroTech® chiller control. The standard minimum ambient temperature is 32°F (0°C). A low ambient option allows operation down to -4°F (-20°C). The minimum ambient temperature is based on still conditions where the wind is not greater than 5 mph. Greater wind velocities will result in reduced discharge pressure, increasing the minimum operating ambient temperature. Field-installed louvers are available and recommended to help allow the chiller to operate effectively down to the ambient temperature for which it was designed.

Condenser Coils

The standard coils on the Trailblazer chiller are an all aluminum alloy microchannel design with a series of flat tubes containing multiple, parallel flow microchannels layered between the refrigerant manifolds. The microchannel coils are designed to withstand 1000+ hour acidified synthetic sea water fog (SWAAT) test (ASTM G85-02) at 120°F (49°C) with 0% fin loss and develop no leaks. The all-aluminum microchannel coils provide superior longevity and durability for non-corrosive applications.

Table 3: Coil/Coating Selection Matrix

Coil Option	Non-Corrosive ¹	Unpolluted Marine ²	Industrial ³	Combined Marine-Industrial ⁴
Standard Microchannel	+++	-	-	-
Epoxy-coated	+++	+++	+++	++

NOTE:

1. Non-corrosive environments may be estimated by the appearance of existing equipment in the immediate area where the chiller is to be placed.
2. Marine environments should take into consideration proximity to shore as well as prevailing wind direction.
3. Industrial contaminants may be general or localized, based on the immediate source of contamination (i.e. diesel fumes due to proximity to a loading dock).
4. Combined marine-industrial are influenced by proximity to shore, prevailing winds, general and local sources of contamination.

Epoxy coil coating

Epoxy coil coating is a water-based, extremely flexible and durable epoxy polymer coating uniformly applied to all coil surfaces through a multi-step, submerged electrostatic coating process. Epoxy-coated condenser coils provide a 10,000+ hour salt spray resistance per ASTM B117-90. The epoxy-coated coils also receive a UV-resistant urethane top-coat to provide superior resistance to degradation from direct sunlight. This coil coating option provides the best overall protection against corrosive marine, industrial or combined atmospheric contamination.

Water Flow Switch

A factory-included thermal dispersion flow switch is necessary to avoid evaporator freeze-up under low or no flow conditions. A thermal dispersion flow switch will be factory-installed on package models.

On remote evaporator models, the flow switch will be shipped loose with the unit for field installation.

Figure 11: Flow Switch

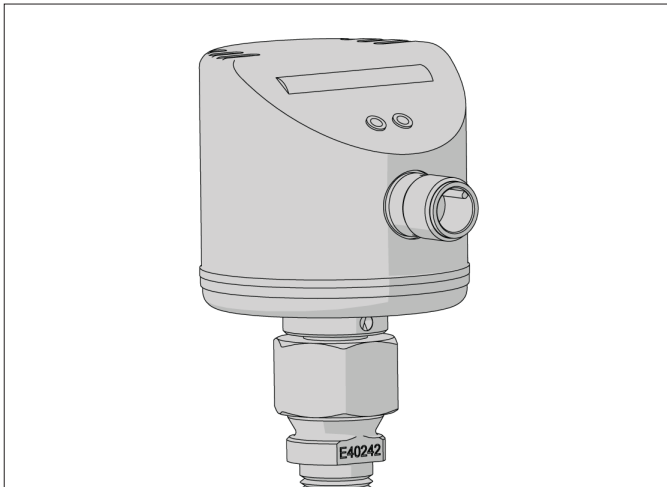

Electronic Expansion Valve

An electronic expansion valve comes standard on all models.

Options and Accessories

RapidRestore and Fast Loading

Allows the unit to restart and to reach full load more quickly than standard in case of a power interruption.

RapidRestore operation will allow for a faster time to full capacity while maintaining stable operation within each circuit. Assuming both circuits are able to run, the effective unit stage up delay will be 30 to 35 seconds, so it will load about four times faster during RapidRestore than the fastest it possibly can during normal operation.

Fast Loading Stand-By Chiller

Gives the system greater response time by starting a stand-by chiller and reaching full load capacity in 120 seconds (assumes conditions require full load capacity).

High Efficiency Fans

As part of the fully configurable Trailblazer model AGZ-F chiller architecture, condenser fan motors can further enhance unit performance by adding three different options for variable speed control:

- Standard: All AC fans, Fixed speed on/off
- Lead fan ECM on each circuit (Required for ambient lower than 32° F)
- All ECM 2hp fans (Required for ambient lower than 32° F)

Units with ECM/DC fan motors also include a sound reduction mode to allow for lower sound operation.

Low Ambient Control (Factory Installed)

Optional fan ECM fans allows unit operation down to -4°F (-20°C). Not available on 380 volt (60 Hz) units.

High Ambient Control Panel

Includes an exhaust fan with rain hood, two inlet screens with filters, necessary controls and wiring. Required for operation from 104°F to 125°F (40°C to 52°C) ambient temperature. This panel is included on units with Low Ambient Control, regardless of ambient temperature, to dissipate additional heat.

BAS Interface (Field Installed)

The preferred module is shipped loose for field installation on the Microtech® chiller controller to provide the interface to the following standard protocols:

- BACnet®/IP
- Modbus®
- BACnet® Ethernet

Electrical Options and Accessories

Single-Point Electrical Connection

Provides a single power connection to the unit power block with compressor circuit breakers or to a disconnect switch with compressor circuit breakers. Either option also available without circuit breakers.

Multi-Point with Disconnect Switch

Provides a disconnect switch mounted inside the power section of the control box with a through-the-door handle for each circuit and no compressor circuit breakers. Requires field-installed circuit protection.

Convenience Outlet

10.0 amp, 115 volt Ground Fault Circuit Interruption (GFCI) outlet in control panel for servicing unit.

Ground Fault Protection

Protects equipment from damage from line-to-ground fault currents less than those required for conductor protection.

High Short Circuit Current Rating (HSCCR)

Provides control panel with high short circuit current rating with a single-point disconnect breaker switch.

Table 4: Standard and HSCCR Panel Ratings

Disconnect Switch Size	Field Wiring Configuration	HSCCR
100	(1) 4-2 AWG	65kA
200	(1) 2 AWG to 3/0	65kA
400	(1) 3/0 to 500 MCM	65kA
600	(1) 4/0 to (2) 300 MCM	65kA @ 240V
		65kA @ 480V
		35kA @ 600V
800	(2) 300 MCM to (2) 400 MCM	65kA @ 240V
		65kA @ 480V
		35kA @ 600V
1200	(4) 250 MCM to (4) 400 MCM	65kA @ 240V
		65kA @ 480V
		35kA @ 600V

Unit Options and Accessories

Remote Evaporators

Trailblazer® models have an evaporator shipped separately for field installation and piping to the outdoor unit. Refrigerant piping information on models with remote evaporators can be found in the current product Installation and Operation Manual, available at www.DaikinApplied.com.

Pump Packages

The on-board, integrated chilled water pump package is available with single or dual pump configurations. See page 6 for general information, and refer to the current product Installation and Operation Manual, available on www.DaikinApplied.com, for detailed information.

Louvers (Base and/or Coil)

Available for the upper portion or both the upper and lower portions of unit. Selecting both will completely enclose the unit with louvers. The louvers protect the coils from hail damage. All AGZ-F models come equipped with base and coil grills as standard.

Epoxy Coated Fins

Microchannel coils coated with baked epoxy protective coating with 10,000+ hour salt spray resistance (ASTM B117-90).

Evaporator Insulation

Double insulation thickness (total of 1.5 inches) for high humidity areas or low fluid temperatures.

Sound Reduction

Acoustical blankets are factory installed on each compressor. They are also available for retrofit field installation.

Shut-off Valves

Suction valves (one per circuit), liquid line shutoff valves, and discharge shutoff valves can be factory mounted.

Evaporator Inlet Strainer

Field-installed evaporator water strainer kit consisting of Y-type strainer, blowdown valve, pipe extension with two Schrader fittings and two grooved couplings.

Hot Gas Bypass

Hot gas bypass permits unit operation down to 10% of full load capacity. This option includes a factory-mounted hot gas bypass valve, solenoid valve, and manual shutoff valve for each circuit.

Engineering Specifications

TRAILBLAZER AIR-COOLED SCROLL COMPRESSOR CHILLERS

PART 1--GENERAL

1.01 SUMMARY

A. A. Section includes design, performance criteria, refrigerants, controls, and installation requirements for air-cooled scroll compressor chillers.

1.02 REFERENCES

A. Comply with applicable Standards/Codes of AHRI 550/590, ANSI/ASHRAE 15, ETL, cETL, NEC, and OSHA as adopted by the State.

B. Units shall meet the efficiency standards of the current version of ASHRAE Standard 90.1, and FEMP standard 2012.

1.03 SUBMITTALS

A. Submit shop drawings and product data in accordance with the specifications.

B. Submittals shall include the following:

1. Dimensioned plan and elevation view drawings, required clearances, and location of all field connections
2. Summary of all auxiliary utility requirements such as electricity, water, etc. Summary shall indicate quality and quantity of each required utility
3. Single line schematic drawing of the field power hookup requirements, indicating all items that are furnished.
4. Schematic diagram of control system indicating points for field interface/connection.
5. Diagram shall fully delineate field and factory wiring.
6. Installation and operating manuals.

1.04 QUALITY ASSURANCE

A. Qualifications: Equipment manufacturer must specialize in the manufacture of the products specified and have five years experience with the type of equipment and refrigerant offered.

B. Regulatory Requirements: Comply with the codes and standards specified.

C. Chiller manufacturer's plant must be ISO registered.

1.05 DELIVERY AND HANDLING

A. Chiller shall be delivered to the job site completely assembled and charged with refrigerant and oil by the manufacturer.

B. Comply with the manufacturer's instructions for rigging and handling equipment.

1.06 WARRANTY

A. Standard Warranty (Domestic): The refrigeration equipment manufacturer's guarantee shall be for a period of one year from date of equipment start-up but not more than 18 months from shipment. The guarantee shall provide for repair or replacement due to failure by material and workmanship that prove defective within the above period, excluding refrigerant.

B. 1st Year Labor Warranty: None included

C. Extended Compressor Warranty: None

D. Extended Unit Warranty: None.

E. Refrigerant Warranty: None.

F. Delay Warranty Start: None.

1.07 MAINTENANCE

A. Maintenance of the chillers shall be the responsibility of the owner and performed in accordance with the manufacturer's instructions.

PART 2--PRODUCTS

2.01 ACCEPTABLE MANUFACTURERS

A. Daikin Applied

B. (Approved Equal)

2.02 UNIT DESCRIPTION

A. Provide and install as shown on the plans factory-assembled, factory-charged air-cooled scroll compressor packaged chillers in the quantity specified. Each chiller shall consist of hermetic tandem scroll compressor sets, brazed plate evaporator, air-cooled condenser section, microprocessor-based control system and all components necessary for controlled unit operation.

B. Chiller shall be functionally tested at the factory to ensure trouble free field operation

2.03 DESIGN REQUIREMENTS

A. Flow Range: The chiller shall have the ability to support variable flow range down to 40% of nominal design (based on AHRI conditions).

B. Operating Range: The chiller shall have the ability to control leaving chilled fluid temperature from 15F to 65F.

C. General: Provide a complete scroll compressor

packaged chiller as specified herein and as shown on the drawings. The unit shall be in accordance with the standards referenced in section 1.02 and any local codes in effect.

D. Performance: Refer to the schedule of performance on the drawings. The chiller shall be capable of stable operation to a minimum percentage of full load (without hot gas bypass) of 25%. Performance shall be in accordance with AHRI Standard 550/590.

E. Acoustics: Sound pressure levels for the unit shall not exceed the following specified levels. All manufacturers shall provide the necessary sound treatment (parts and labor) to meet these levels if required. Sound data shall be provided with the quotation. Test shall be in accordance with AHRI Standard 370.

Sound Pressure (at 30 feet)											
63 Hz	125 Hz	250 Hz	500 Hz	1000 Hz	2000 Hz	4000 Hz	8000 Hz	Overall dBA	75% Load dBA	50% Load dBA	25% Load dBA
Sound Power											
63 Hz	125 Hz	250 Hz	500 Hz	1000 Hz	2000 Hz	4000 Hz	8000 Hz	Overall dBA	75% Load dBA	50% Load dBA	25% Load dBA

2.04 CHILLER COMPONENTS

A. Compressor

1. The compressors shall be sealed hermetic, scroll type with crankcase oil heater and suction strainer. The compressor motor shall be refrigerant gas cooled, high torque, hermetic induction type, two-pole, with inherent thermal protection on all three phases and shall be mounted on RIS vibration isolator pads. The compressors shall be equipped with an internal module providing compressor protection and communication capability.

B. Evaporator

1. The evaporator shall be a compact, high efficiency, dual circuit, brazed plate-to-plate type heat exchanger consisting of parallel stainless steel plates. Vent and drain connections shall be provided in the inlet and outlet chilled water piping by the installing contractor.
2. The evaporator shall be protected with an external, electric resistance heater plate. The evaporator and suction piping to the compressors shall be insulated with 3/4" (19 mm) thick CFC and HCFC-free closed-cell flexible elastomeric foam insulation material with 100% adhesive coverage. The insulation shall have an additional outer protective layer of 3mm thick PE embossed film to provide superior damage resistance. Insulation without the protective outer film shall not be acceptable. UV resistance level shall meet or exceed a rating of 'Good' in accordance with the UNI ISO 4892 - 2/94 testing method. This combination of a heater plate and insulation shall provide freeze protection down to -20°F

(-29°C) ambient air temperature.

3. The water-side maximum design pressure shall be rated at a minimum of 469 psig (3235 kPa). Evaporators shall be designed and constructed according to, and listed by, Underwriters Laboratories (UL).

C. Condenser

1. Condenser fans shall be propeller type arranged for vertical air discharge and individually driven by direct-drive fan motors. The fans shall be equipped with a heavy-gauge vinyl-coated fan guard. Fan motors shall be TEAO type with permanently lubricated ball bearings, inherent overload protection, three-phase, direct-drive, 1140 rpm. Each fan section shall be partitioned to avoid cross circulation.
2. Coil shall be microchannel design and shall have a series of flat tubes containing multiple, parallel flow microchannels layered between the refrigerant manifolds. Tubes shall be 9153 aluminum alloy. Tubes made of 3102 alloy or other alloys of lower corrosion resistance shall not be accepted. Coils shall consist of a two-pass arrangement. Each condenser coil shall be factory leak tested with high-pressure air under water. Coils shall withstand 1000+ hour acidified synthetic sea water fog (SWAAT) test (ASTM G85-02) at 120°F (49°C) with 0% fin loss and develop no leaks.

D. Refrigerant Circuit

1. Each of the two refrigerant circuits shall include a replaceable-core refrigerant filter-drier, sight glass with moisture indicator, liquid line solenoid valve (no exceptions), expansion valve, and insulated suction line.

E. Construction

1. Unit formed sheet metal components shall be painted using a corrosion resistant paint system, for aesthetics and long-term durability. Paint system will include a base primer with a high-quality polyester resin topcoat. Painted galvanized parts shall be G60 or greater and finished, unabraded panel surfaces shall be capable to be exposed to an ASTM B117 salt spray environment and exhibit no visible red rust at a minimum of 3,000 hours exposure. Finished, abraded surfaces shall be tested per ASTM D1654, having a mean scribe creepage not exceeding 1/16" at 1,000 hours minimum exposure to an ASTM B117 salt spray environment.
2. Upper condenser coil and base section of unit shall have protective, 12 GA, PVC-coated, wire grille guards and have painted steel wraps enclosing the coil end sections and piping.

F. Control System

1. A centrally located weatherproof control panel shall contain the field power connection points, control interlock terminals, and control system. Box shall be designed in accordance with NEMA 3R rating. Power and starting components shall

include factory circuit breaker for fan motors and control circuit, individual contactors for each fan motor, solid-state compressor three-phase motor overload protection, inherent fan motor overload protection and two power blocks (one per circuit) for connection to remote, contractor supplied disconnect switches. Hinged access doors shall be lockable. Barrier panels or separate enclosures are required to protect against accidental contact with line voltage when accessing the control system. Shall include optional single-point connection to a non-fused disconnect switch with through-the-door handle and compressor circuit breakers.

2. Shall include high short circuit current rating of 65,000 amps with single-point disconnect switch

G. Unit Controller

1. An advanced DDC microprocessor unit controller with a 5-line by 22-character liquid crystal display provides the operating and protection functions. The controller shall take preemptive limiting action in case of high discharge pressure or low evaporator pressure. The controller shall contain the following features as a minimum:
 2. The unit shall be protected in two ways: (1) by alarms that shut the unit down and require manual reset to restore unit operation and (2) by limit alarms that reduce unit operation in response to some out-of-limit condition. Shut down alarms shall activate an alarm signal.
3. Shutdown Alarms:
 - a. No evaporator water flow
 - b. Sensor failures
 - c. Low evaporator pressure
 - d. Evaporator freeze protection
 - e. High condenser pressure
 - f. Outside ambient temperature (auto-restart)
 - g. Motor protection system
 - h. Phase voltage protection (Optional)
4. Limit Alarms
 - a. Condenser pressure stage down, unloads unit at high discharge pressure.
 - b. Low ambient lockout, shuts off unit at low ambient temperatures
 - c. Low evaporator pressure hold, holds stage #1 until pressure rises
 - d. Low evaporator pressure unload, shuts off one compressor
5. Unit Enable Selection
 - a. Enables unit operation from either local keypad, digital input, or BAS

6. Unit Mode Selection
 - a. Selects standard cooling, Ice, Glycol, or test operation mode.
7. Analog Inputs:
 - a. Reset of leaving water temperature, 4-20 mA
 - b. Current Limit
8. Digital Inputs
 - a. Unit off switch
 - b. Remote start/stop
 - c. Flow switch
 - d. Ice mode switch, converts operation and setpoints for ice production
 - e. Motor protection
9. Digital Outputs
 - a. Shutdown alarm; field wired, activates on an alarm condition, off when alarm is cleared
 - b. Evaporator pump; field wired, starts pump when unit is set to start
10. Condenser fan control - The unit controller shall provide control of condenser fans based on compressor discharge pressure.
11. Building Automation System (BAS) Interface
 - a. Factory mounted DDC controller(s) shall support operation on a BACnet® or Modbus® network via one of the data link / physical layers listed below as specified by the successful Building Automation System (BAS) supplier.
 - b. BACnet MS/TP master (Clause 9)
 - c. BACnet IP, (Annex J)
 - d. BACnet ISO 8802-3, (Ethernet)
 - e. The information communicated between the BAS and the factory mounted unit controllers shall include the reading and writing of data to allow unit monitoring, control and alarm notification as specified in the unit sequence of operation and the unit points list.
 - f. All communication from the chiller unit controller as specified in the points list shall be via standard BACnet objects. Proprietary BACnet objects shall not be allowed. BACnet communications shall conform to the BACnet protocol (ANSI/ASHRAE135-2001). A BACnet Protocol Implementation Conformance Statement (PICS) shall be provided along with the unit submittal.
12. Factory-mounted thermal dispersion type flow switch

2.05 OPTIONS AND ACCESSORIES

A. The following options are to be included:

1. Low Ambient Control: Provide fan cycling control to allow unit operation down to 32°F
2. Phase loss with under/over voltage protection and with LED indication of the fault type to guard against compressor motor burnout.
3. The following accessories, if selected, are to be included:
 - a. Spring vibration isolators for field installation
 - b. Rubber-in-shear vibration isolators for field installation
 - c. Factory-mounted thermal dispersion type flow switch
 - d. Field-mounted, paddle type, chilled water flow switch field wired to the control panel
 - e. Wye strainer, to be installed at the evaporator inlet and sized for the design flow rate, with perforation diameter of 0.063" with blowdown valve and Victaulic couplings (factory mounted or field installed)
 - f. 115V GFI convenience outlet

B. Optional Factory-Installed Pump Package: The pump package shall be factory mounted and wired on the chiller. The chiller controller shall provide a pump start/stop signal when operation is required. On dual pump systems, the chiller shall provide also automatic alternating of pump starts and duty/standby functionality. The package shall be equipped with:

1. Single Pump Model 4380: single spring inside seal, vertical, in-line, radially split-case pump, serviceable without breaking pipe connections. The motor and pump rotating assembly shall be serviceable without removing the pump casing from the line - OR
2. Dual Pumps in a Single Casting Models 4372 and 4362: single-spring inside-seal vertical, in-line, radially split-case pumps, mounted in a common casing with a common inlet connection and outlet connection and including a flapper valve to prevent recirculation when only one pump is operating. The pumps shall be designed for duty/standby, not parallel operation. Pump package shall also be equipped with:
 - a. "Y" type inlet strainer
 - b. Pump VFD for variable chilled water flow capability
 - c. Water pressure gauges (suction and discharge) shall be factory installed.
 - d. Combination triple-duty outlet valve having a drip-tight discharge shutoff valve, non-slam check valve, and flow throttling valve
 - e. Combination suction guide with flow stabilizing outlet vanes and stainless steel

strainer with a disposable fine-mesh strainer for start-up

- f. Factory power and control wiring from the chiller to the pump package control panel
- g. Flow switch mounted and wired
- h. Interconnecting schedule 40 piping with Victaulic couplings
- i. Insulation of all cold surfaces
3. These pump package accessories, if selected, will also be included:
 - a. Expansion tank with size increments from 4.4 to 90 gallons, field installed (14 gallon can be factory mounted)
 - b. Air separator with air vent, field installed
 - c. Storage tanks, vertical, insulated, 150, 300, 600, 1000 gallon sizes with optional immersion heater, field installed.

PART 3--EXECUTION

3.01 INSTALLATION

- A. Install in strict accordance with manufacturer's requirements, shop drawings, and contract documents.
- B. Adjust and level chiller in alignment on supports.
- C. Coordinate electrical installation with electrical contractor.
- D. Coordinate controls with control contractor.
- E. Install a field-supplied or optional manufacturer-supplied strainer in the chilled water return line at the evaporator inlet that meets manufacturer perforation size specifications.

3.02 START-UP

- A. Provide testing and starting of machine, and instruct the Owner in its proper operation and maintenance.

Limited Warranty

DAIKIN APPLIED AMERICAS INC.
LIMITED PRODUCT WARRANTY
(United States and Canada)

WARRANTY

Daikin Applied Americas Inc. dba Daikin Applied (“Company”) warrants to contractor, purchaser and any owner of the product (collectively “Owner”) that, subject to the exclusions set forth below Company, at its option, will repair or replace defective parts in the event any product manufactured by Company, including products sold under the brand name Daikin and used in the United States or Canada, proves defective in material or workmanship within twelve (12) months from initial startup or eighteen (18) months from the date shipped by Company, whichever occurs first. Authorized replacement parts are warranted for the remainder of the original warranty. All shipments of such parts will be made FOB factory, freight prepaid and allowed. Company reserves the right to select carrier and method of shipment. In addition, Company provides labor to repair or replace warranty parts during Company normal working hours on products with rotary screw compressors or centrifugal compressors. Warranty labor is not provided for any other products.

Company must receive the Registration and Startup Forms for products containing motor compressors and/or furnaces within ten (10) days of original product startup, or the ship date and the startup date will be deemed the same for determining the commencement of the warranty period and this warranty shall expire twelve (12) months from that date. For additional consideration, Company will provide an extended warranty(ies) on certain products or components thereof. The terms of the extended warranty(ies) are shown on a separate extended warranty statement.

No person (including any agent, sales representative, dealer or distributor) has the authority to expand the Company’s obligation beyond the terms of this express warranty or to state that the performance of the product is other than that published by Company.

EXCLUSIONS

1. If free warranty labor is available as set forth above, such free labor does not include diagnostic visits, inspections, travel time and related expenses, or unusual access time or costs required by product location.
2. Refrigerants, fluids, oils and expendable items such as filters are not covered by this warranty.
3. This warranty shall not apply to products or parts : (a) that have been opened, disassembled, repaired, or altered, in each case by anyone other than Company or its authorized service representative; (b) that have been subjected to misuse, abuse, negligence, accidents, damage, or abnormal use or service; (c) that have not been properly maintained; (d) that have been operated or installed, or have had startup performed, in each case in a manner contrary to Company’s printed instructions; (e) that have been exposed, directly or indirectly, to a corrosive atmosphere or material such as, but not limited to, chlorine, fluorine, fertilizers, waste water, urine, rust, salt, sulfur, ozone, or other chemicals, contaminants, minerals, or corrosive agents; (f) that were manufactured or furnished by others and/or are not an integral part of a product manufactured by Company; or (g) for which Company has not been paid in full.
4. This warranty shall not apply to products with rotary screw compressors or centrifugal compressors if such products have not been started, or if such startup has not been performed, by a Daikin Applied or Company authorized service representative.

SOLE REMEDY AND LIMITATION OF LIABILITY

THIS WARRANTY CONSTITUTES THE SOLE WARRANTY MADE BY COMPANY. COMPANY’S LIABILITY TO OWNER AND OWNER’S SOLE REMEDY UNDER THIS WARRANTY SHALL NOT EXCEED THE LESSER OF: (i) THE COST OF REPAIRING OR REPLACING DEFECTIVE PRODUCTS; AND (ii) THE ORIGINAL PURCHASE PRICE ACTUALLY PAID FOR THE PRODUCTS. COMPANY MAKES NO REPRESENTATION OR WARRANTY, EXPRESS OR IMPLIED, REGARDING PREVENTION OF MOLD/MOULD, FUNGUS, BACTERIA, MICROBIAL GROWTH, OR ANY OTHER CONTAMINATES. THIS WARRANTY IS GIVEN IN LIEU OF ALL OTHER WARRANTIES, INCLUDING, WITHOUT LIMITATION, THE IMPLIED WARRANTIES OF MERCHANTABILITY, FITNESS FOR A PARTICULAR PURPOSE, AND NON-INFRINGEMENT, WHICH ARE HEREBY DISCLAIMED. IN NO EVENT AND UNDER NO CIRCUMSTANCE SHALL COMPANY BE LIABLE TO OWNER OR ANY THIRD PARTY FOR INCIDENTAL, INDIRECT, SPECIAL, CONTINGENT, CONSEQUENTIAL, DELAY OR LIQUIDATED DAMAGES FOR ANY REASON, ARISING FROM ANY CAUSE WHATSOEVER, WHETHER THE THEORY FOR RECOVERY IS BASED IN LAW OR IN EQUITY, OR IS UNDER A THEORY OF BREACH CONTRACT OR WARRANTY, NEGLIGENCE, STRICT LIABILITY, OR OTHERWISE. THE TERM “CONSEQUENTIAL DAMAGE” INCLUDES, WITHOUT LIMITATION, THOSE DAMAGES ARISING FROM BUSINESS INTERRUPTION OR ECONOMIC LOSS, SUCH AS LOSS OF ANTICIPATED PROFITS, REVENUE, PRODUCTION, USE, REPUTATION, DATA OR CROPS.

ASSISTANCE

To obtain assistance or information regarding this warranty, please contact your local sales representative or a Daikin Applied office.



Daikin Applied Training and Development

Now that you have made an investment in modern, efficient Daikin Applied equipment, its care should be a high priority. For training information on all Daikin Applied HVAC products, please visit us at www.DaikinApplied.com and click on Training, or call 540-248-9646 and ask for the Training Department.

Warranty

All Daikin Applied equipment is sold pursuant to its standard terms and conditions of sale, including Limited Product Warranty. Consult your local Daikin Applied representative for warranty details. To find your local Daikin Applied representative, go to www.DaikinApplied.com.

Aftermarket Services

To find your local parts office, visit www.DaikinApplied.com or call 800-37PARTS (800-377-2787). To find your local service office, visit www.DaikinApplied.com or call 800-432-1342.

This document contains the most current product information as of this printing. For the most up-to-date product information, please go to www.DaikinApplied.com.

Products manufactured in an ISO Certified Facility.