



Catalog 1103-16

Enfinity™ Vertical Water Source Heat Pumps

Floor Model VFC & VFW

Unit Sizes 009 – 070 (3/4 to 6 Tons) • R-410A Refrigerant



Model Nomenclature	3	Fan Performance	31
AHRI Performance Data	4	PSC Motor CFM - Sizes 009 - 070	31
Water Loop	4	EC Constant Torque Motor CFM Values - Sizes 009 - 012	31
Ground Loop	5	Constant CFM motor CFM values - Sizes 015 - 070	32
Introduction	6	Physical Data	33
Enfinity™ Water Source Heat Pumps	6	Dimensional Data	34
Features and Options	7	Sizes 009 & 012 – Left Hand and Right Hand Return	34
Flexible Configurations	8	Sizes 015, 019, 024 – Left Hand and Right Hand Return	35
Control Options	13	Sizes 030, 036 – Left Hand and Right Hand Return	36
MicroTech® III Unit Controller with LONWORKS® or BACnet®		Sizes 042, 048 – Left Hand and Right Hand Return	37
Communication Module	14	Sizes 060, 070 – Left Hand and Right Hand Return	38
MicroTech III Unit Controller with Communication Modules		Control Accessories	39
Features	14	Thermostats For Use with MicroTech III Standalone –	
MicroTech® III Unit Controller	15	Wiring	42
I/O Expansion Module	18	Sensors Used with MicroTech III Control – Building	
Applications	19	Automated System Operation – Wiring	43
Typical Cooling and Heating Refrigeration Cycles	19	Accessories	45
Systems	20	Supply and Return Water Hoses	45
Application Considerations	22	Combination Balancing and Shutoff (Ball) Valves	45
Ductwork and Attenuation	23	Field Installed Controls	45
Piping	23	Two-Inch Filter Rack	45
Condensate Drain	23	Typical Wiring Diagrams	46
Unit Selection	24	MicroTech III Unit Controller (Standalone)	46
Operating Limits	25	MicroTech III Controller with EC Motor and Optional I/O	
Air Limits	25	Expansion Module	47
Fluid Limits	25	MicroTech III Controller with EC Motor, Electric Heat Coil	
Additional Information for Initial Start-Up Only	25	with Optional I/O Expansion Module	48
Correction Factors	26	MicroTech III Controller with EC Motor, HGRH and Optional	
Airflow Correction Factors – Units with PSC Motor	26	I/O Expansion Module	49
Antifreeze Correction Factors	26	MicroTech III Controller with PSC Motor, and I/O Expansion	
Electrical Data	27	Module for Hot Gas Reheat Control (Unit Sizes 019-070)	50
Unit with PSC Motor – without Options	27	Engineering Guide Specifications	51
Unit with EC Motor – without Options	28	Appendix A:	54
Unit with PSC Motor – 10kW Electric Heat Coil	29		
Unit with PSC Motor – 5kW Electric Heat Coil	29		
Unit with EC Motor – 10kW Electric Heat Coil	30		
Unit with EC Motor – 5kW Electric Heat Coil	30		

Category	Code Item	Code Position	Code	Designation & Description
Product Category	01	1	W =	Water Source Heat Pump
Product Identifier	02	2-4	VFC = VFW =	R410A, Floor Mounted, Standard Range R410A, Floor Mounted, Geothermal Range
Design Series (Vintage)	03	5	1 = 2 = 3 = 4 =	A Design B Design C Design D Design
Nominal Capacity	04	6-8	009 = 012 = 015 = 019 = 024 = 030 = 036 = 042 = 048 = 060 = 070 =	9,000 Btuh Nominal Cooling 12,000 Btuh Nominal Cooling 15,000 Btuh Nominal Cooling 19,000 Btuh Nominal Cooling 24,000 Btuh Nominal Cooling 30,000 Btuh Nominal Cooling 36,000 Btuh Nominal Cooling 42,000 Btuh Nominal Cooling 48,000 Btuh Nominal Cooling 60,000 Btuh Nominal Cooling 70,000 Btuh Nominal Cooling
Controls	05	9	S = H = J =	MicroTech® III Unit Controller MicroTech III Controller w/LONWORKS Comm Module MicroTech III Controller w/BACnet Comm Module
Voltage	06	10	A = E = J = F = K = L =	115-60-1 (Sizes 007-012 only) 208-230/60/1 265/277-60-1 208-230/60/3 460/60/3* 575/60/3
Return Air	08	12	L = R =	Left Right
Discharge Air	09	13	T =	Top
Blower Motor	10	14-15	01 = 03 = 14 =	Standard PSC Low Static ECM
Construction Type	12	18	A = B = C = D = E = F = G = H = J = K = L = M = N = Q = R =	Standard Standard with 2" Filter Rack Standard with Compressor Sound Blanket Standard with Compressor Sound Blanket and 2" Filter Rack Indoor Air Quality (IAQ) Indoor Air Quality (IAQ) with 2" Filter Rack Indoor Air Quality (IAQ) with Compressor Sound Blanket Indoor Air Quality (IAQ) with Compressor Sound Blanket and 2" Filter Rack Sound Package Sound Package with 2" Filter Rack Standard w/4" Merv 13 Filter Rack Standard w/Compressor Sound Blanket and 4" Merv 13 Filter Rack Indoor Air Quality (IAQ) w/4" Merv 13 Filter Rack Indoor Air Quality (IAQ) w/Compressor Sound Blanket and 4" Merv 13 Filter Rack Sound Package w/4" Merv 13 Filter Rack
Heating Options	14	20	A = B =	5.0 kW Electric Heat 10.0 kW Electric Heat
Dehumidification	15	21-22	AA =	Hot Gas Reheat Coil
Refrigerant	20	33	A =	R410A
Cabinet Electrical	22	35-37	75V =	75VA Control Transformer
Water Flow Control	23	38	C = V = H = D = K = J =	2-Way Motorized 1/2" Isolation Valve, General Close-Off Pressure N.C. 2-Way Motorized 1/2" Isolation Valve, General Close-Off Pressure N.O. 2-Way Motorized 1/2" Isolation Valve, High Close-Off Pressure N.C. 2-Way Motorized 3/4" Isolation Valve, General Close-Off Pressure N.C. 2-Way Motorized 3/4" Isolation Valve, General Close-Off Pressure N.O. 2-Way Motorized 3/4" Isolation Valve, High Close-Off Pressure N.C.
Color			Y =	Galvanized

Notes: * A 460 volt, 3-phase unit that utilize an EC fan motor will need a 4-wire WYE voltage supply with 3 hot leads and a neutral wire to power the EC motor with neutral and one hot for 277/60/1 voltage to the EC motor.

Water Loop

Rated in accordance with ISO standard 13256-1

PSC & EC Motor

In English (IP) Units				PSC Fan Motor				ECM Fan Motor			
Enfinity Vertical				Cooling		Heating		Cooling		Heating	
				EWT 86°F		EWT 68°F		EWT 86°F		EWT 68°F	
Unit Size	Airflow CFM	Fluid Flow Rate GPM	Voltages	Capacity Btuh	EER Btuh/W	Capacity Btuh	COP	Capacity Btuh	EER Btuh/W	Capacity Btuh	COP
009	300	2.3	115-60-1	9060	14.0	10600	4.7	9060	14.0	10600	4.7
			208/230-60-1								
			265/277-60-1								
012	400	3.0	208/230-60-1	12000	14.4	14000	4.8	12000	14.4	14000	4.8
			265/277-60-1								
015	500	3.6	208/230-60-1	14700	16.0	16100	5.1	14700	16.0	16100	5.1
			265/277-60-1								
019	600	4.7	208/230-60-1	18000	15.2	19200	4.4	18000	16.6	19200	4.6
			265/277-60-1								
024	800	5.8	208/230-60-1	23800	15.1	26700	4.9	24100	16.3	26300	5.2
			208/230-60-3								
			265/277-60-1								
030	1000	7.3	208/230-60-1	30000	17.0	33400	5.2	29900	17.0	33400	5.4
			265/277-60-1								
			208/230-60-3								
036	1300	9.5	208/230-60-1	39500	14.8	45000	4.6	39900	15.0	44500	4.6
			208/230-60-3								
			460-60-3								
042	1400	11.0	208/230-60-1	43900	15.0	52500	4.8	44200	16.2	52300	5.1
			208/230-60-3								
			460-60-3								
			575-60-3								
048	1600	12.0	208/230-60-1	48100	14.7	56800	4.8	48700	16.0	56400	5.1
			208/230-60-3								
			460-60-3								
			575-60-3								
060	2000	15.5	208/230-60-1	63200	15.1	68300	4.7	63600	15.7	67700	4.4
			208/230-60-3								
			460-60-3								
			575-60-3								
070	2160	19.0	208/230-60-3	75400	13.5	87300	4.4	76200	14.0	86300	4.5
			460-60-3								
			575-60-3								

1. Cooling capacity is based on 80.6°F db, 66.2°F wb (27/19°C) EAT and 86°F (30°C) EWT.

2. Heating capacity is based on 68°F db, 59.0°F wb (20/15°C) EAT and 68°F (20°C) EWT.

Note: All published flow rates are evaluated in accordance with ANSI/ASHRAE Standard 51-1999/AMCA Standard 210-1999, Laboratory Methods of Testing Fans for Aerodynamic Performance Rating. The tested values are then corrected to standard air which may differ from measured or actual based on barometer, dry bulb and wet bulb temperatures. The Constant CFM technology is a motor programming technique that predicts motor speed changes due to fan pressure variations to help maintain consistent CFM for a given speed setting. Although this technology makes significant improvements to equipment airflow, variations in field conditions and measurements must be considered during test and balance of specified CFM requirements. As a result, flow rates may differ from those in the catalog tables and selection software.

Ground Loop

Rated in accordance with ISO standard 13256-1

PSC & EC Motor

In English (IP) Units				PSC Fan Motor				ECM Fan Motor			
Enfinity Vertical				Cooling		Heating		Cooling		Heating	
				EWT 77°F		EWT 32°F		EWT 77°F		EWT 32°F	
Unit Size	Airflow CFM	Fluid Flow Rate GPM	Voltages	Capacity Btuh	EER Btuh/W	Capacity Btuh	COP	Capacity Btuh	EER Btuh/W	Capacity Btuh	COP
009	300	2.3	115-60-1	9720	16.7	7020	3.3	9720	16.7	7020	3.3
			208/230-60-1								
			265/277-60-1								
012	400	3.0	208/230-60-1	12700	16.9	9300	3.5	12700	16.9	9300	3.5
			265/277-60-1		16.6		3.5		16.6		3.5
015	500	3.6	208/230-60-1	15700	19.6	10000	3.5	15700	19.6	10000	3.5
			265/277-60-1	15200	19.6	10000	3.3	15200	19.6	10000	3.3
019	600	4.7	208/230-60-1	19400	17.3	13700	3.5	19700	19.0	13400	3.7
			265/277-60-1								
024	800	5.8	208/230-60-1	24800	14.9	17800	3.1	25100	19.2	17500	3.8
			208/230-60-3								
			265/277-60-1								
030	1000	7.3	208/230-60-1	30700	19.1	22300	3.9	30600	19.3	22300	4.0
			265/277-60-1								
			208/230-60-3								
036	1300	9.5	208/230-60-1	40300	17.3	30300	3.4	40500	16.6	30000	3.3
			208/230-60-3								
			460-60-3								
042	1400	11.0	208/230-60-1	45400	17.0	35100	3.6	46100	18.9	34400	3.8
			208/230-60-3								
			460-60-3								
			575-60-3								
048	1600	12.0	208/230-60-1	51600	15.8	40300	3.4	50200	18.2	37600	3.8
			208/230-60-3								
			460-60-3								
			575-60-3								
060	2000	15.5	208/230-60-1	65100	16.3	47000	3.5	66000	18.0	46000	3.8
			208/230-60-3								
			460-60-3								
			575-60-3								
070	2160	19.0	208/230-60-3	76500	13.7	58900	3.1	78400	16.2	56800	3.6
			460-60-3								
			575-60-3								

1. Cooling capacity is based on 80.6°F DB, 66.2°F WB entering air temperature (EAT) and 77°F (25°C) EWT.

2. Heating Capacity is based on 68.0°F db, 59.0°F wb entering air temperature (EAT) and 32°F (0°C) EWT.

Note: All published flow rates are evaluated in accordance with ANSI/ASHRAE Standard 51-1999/AMCA Standard 210-1999, Laboratory Methods of Testing Fans for Aerodynamic Performance Rating. The tested values are then corrected to standard air which may differ from measured or actual based on barometer, dry bulb and wet bulb temperatures. The Constant CFM technology is a motor programming technique that predicts motor speed changes due to fan pressure variations to help maintain consistent CFM for a given speed setting. Although this technology makes significant improvements to equipment airflow, variations in field conditions and measurements must be considered during test and balance of specified CFM requirements. As a result, flow rates may differ from those in the catalog tables and selection software.

Enfinity™ Water Source Heat Pumps

More than 30 years ago, McQuay designed the first complete line of water source heat pumps for high efficiency, individually-zoned comfort control in offices, schools, assisted living facilities, manufacturing facilities and other commercial buildings. Our reputation for outstanding reliability and quiet operation has been reinforced in thousands of successful installations.

Enfinity water source heat pumps incorporate the best of our past and the best of what's new. Using feedback from building owners, consulting engineers, contractors and service engineers, we designed Enfinity products to give you maximum flexibility to design, install, operate and maintain the ideal water source heat pump system for your building project. And we incorporated non-ozone depleting R-410A refrigerant, which—along with high Energy Efficiency Ratios (EER's)—helps preserve our environment and precious energy resources.

With Enfinity Water Source Heat Pumps, you benefit from:

High efficiency that minimizes environmental impact and lowers operating costs

- Units exceed ASHRAE Standard 90.1 minimum requirements
- High efficiency standard range or geothermal application flexibility

Easy, low-cost design and installation

- Two configurations for each unit size (left or right return) allow you to specify units to fit space requirements and to design the system using minimum ductwork and piping
- Four cabinet sizes, each with Daikin's small footprint design, make it easy to meet the space requirements of your new construction or replacement application
- Flush FPT water fittings allow easy, one-wrench tightening of hose kits and help reduce delays caused by shipping damage
- Open Choices™ controls feature allows easy, low cost integration with a Building control Automation System of your choice
- Factory-installed filter rack saves time and expense to field-install a filter rack
- Factory-installed electric heat and EC motor options help you meet more specific application requirements with minimum design or installation time and expense

Easy, low-cost maintenance

- Easy access to the unit compressor (2-sides), fan section (1-side), motor (1-side) and unit controls (front access)
- A removable orifice ring allows the blower and motor to be removed without removing the blower housing or disconnecting the unit from the ductwork

Quiet operation

- Large fan wheel allows the fan motor to operate at lower speed for quieter operation
- Two quiet compressor selections (depending on voltage and size variations) including rotary (sizes 009 to 015), and scroll compressors (sizes 019 to 070)

Superior Indoor Air Quality (IAQ)

- Double-sloped, corrosion resistant polypropylene drain pan promotes positive condensate drainage
- Optional closed-cell foam insulation (no glass fibers in air stream)
- Optional Hot Gas Reheat Coil provides superior humidity control

R-410A refrigerant with zero ozone depletion potential or phase-out date

- R-410A is classified as A1/A1 – lower toxicity, no flame propagation – per ASHRAE Standard 31.

Exceeds ASHRAE 90.1 Minimum Efficiencies

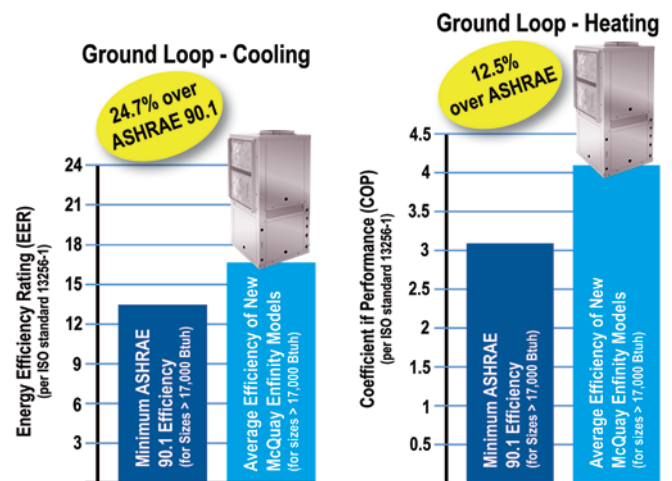

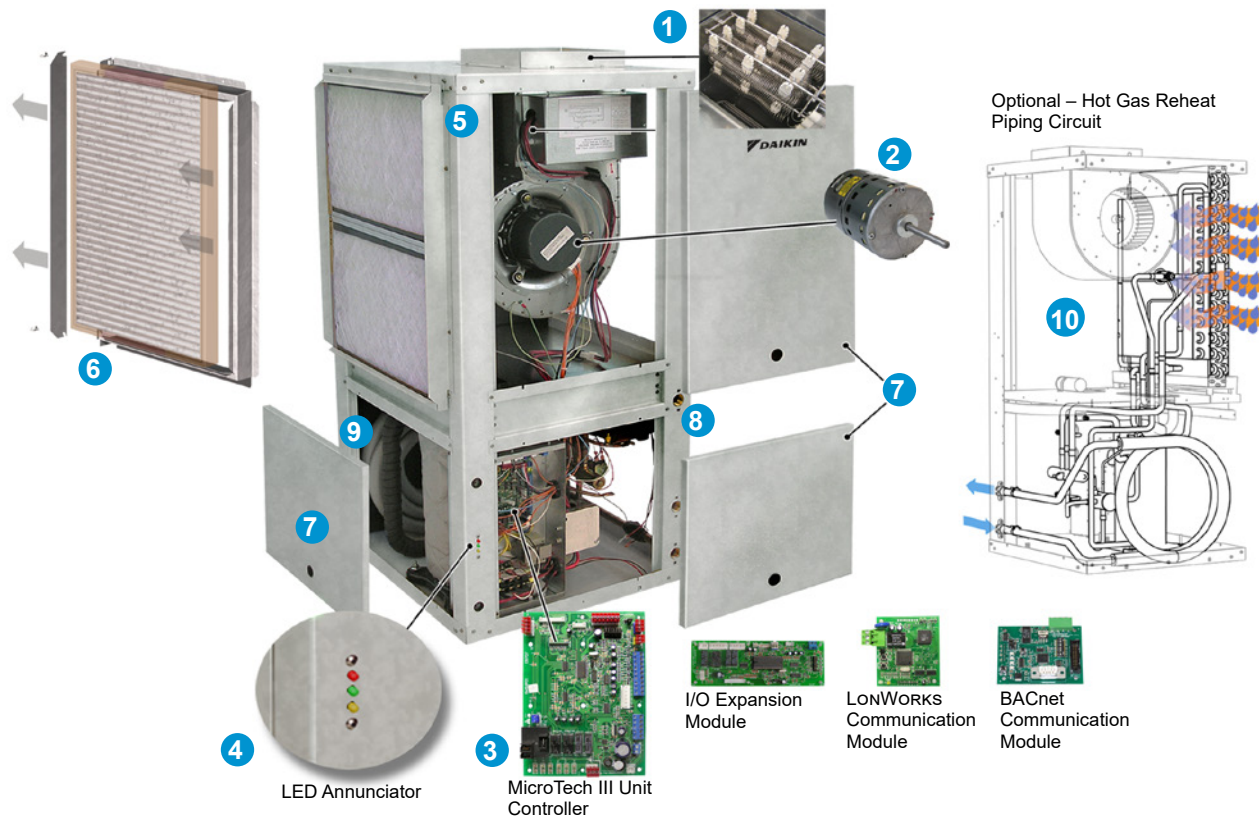

1 Electric heat (optional)

- Integral electric heat coil provides emergency heat when conditions require.

2 Smart ECM fan control with 4-position switch (option)

- EC motor provides quiet, efficient operation while maintaining constant CFM over its static operating range.

3 MicroTech® III unit controller

- Designed for flexibility, the main control board is used in standalone applications. An optional I/O expansion module can be used to control optional electric heat. A separate LONWORKS® or BACnet® communication module can be easily snapped onto the board to accommodate the building automation system of your choice.

4 LED annunciator

- External LED status lights display fault conditions to provide easy troubleshooting and diagnosis.

5 Compact cabinet

- The standard unit is constructed of unpainted G-60 galvanized steel, with the smallest possible footprint.

6 Filter & filter rack

- Units come standard with a 1" (25.4 mm) thick throwaway filter mounted in a 4-sided combination filter rack and return air duct collar. This eliminates the added labor and cost to field-mount brackets. Filters can be easily removed from either side. As a factory-installed selectable option units will have a 2" throwaway filter in a 4-sided filter rack with duct collar, or a 4" thick, high efficiency Merv 13 filter in a 4-sided filter rack with duct collar. The filter rack will have a removable access door on the side to accommodate filter removal.

7 Removable access panels

- Two front panels provide easy access to the blower motor and unit controls. Two rear panels provide easy access to the fan housing and compressor section.

8 Piping connections

- Water connections are FPT water fittings, flush with the outside of the cabinet for easy one-wrench connection to units. A large condensate connection provides proper condensate removal.

9 Coaxial heat exchanger

- Designed for maximum heat transfer at normal and low water flow rates with minimum pressure drop. The inside tube is deeply fluted to enhance heat transfer and minimize fouling. A cupro-nickel heat exchanger is available as a selectable option.

10 Hot gas reheat coil (optional)

- For improved indoor climate control, Daikin Applied offers accurate and cost effective dehumidification control using a hot gas reheat option known as smart dehumidification. Hot gas reheat with smart dehumidification is an excellent solution for applications where maintaining low humidity in a space is crucial.

Flexible Configurations

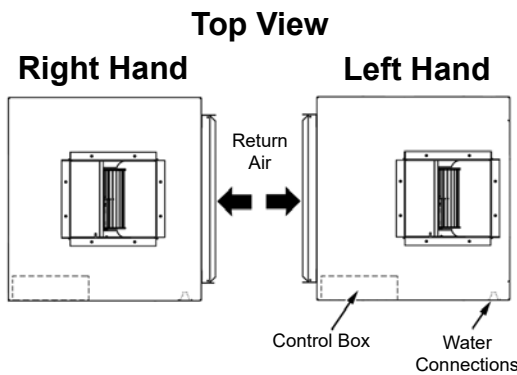

Cabinet

The Enfinity Vertical Water Source Heat Pump is factory assembled and tested for reliability. Five unique cabinet sizes make up our 3/4 through 6 ton (1.8 through 21.2 kW) vertical heat pump product line. The consistent shape makes layout simple. Water, condensate and duct connections are all in similar locations to simplify installation. The fan section is separated from the compressor section with an insulated divider panel for maximum sound attenuation. A large removable panel provides easy service access to the blower and motor.

The cabinet is constructed of unpainted, G-60 galvanized steel. The interiors of the top and side panels are covered with 1/2" thick (13 mm), 1-1/2 lb. (681 g) density coated glass fiber as standard. An optional closed cell insulation is available for applications with more stringent IAQ requirements.

Cabinet Configurations

For maximum flexibility, each vertical unit is available in either a left-hand or right-hand return air arrangement to provide the optimum piping location and service access. The mirror image design of the units lets you configure the system using minimum ductwork and piping. This helps reduce design, material and installation costs.

Filter Rack

The filter is supported by factory-mounted brackets that allow for face removal. Units come standard with a 1" (25.4 mm) thick throwaway filter mounted in a combination filter rack and return air duct collar, thus eliminating field mounted brackets. The filter can be removed from the right or left side.

- As a factory-installed selectable option units will have a 2" throwaway filter in a 4-sided filter rack with duct collar. Where high indoor air quality is required units will have a 4" thick, high efficiency Merv 13 filter in a 4-sided filter rack with duct collar. The filter rack can be mounted for left hand or right hand filter removal by rotating it 180 degrees. Two thumb screws allow easy removal of the access door for quick filter changes without using a tool.

Figure 1: Optional 2" or 4" filter rack

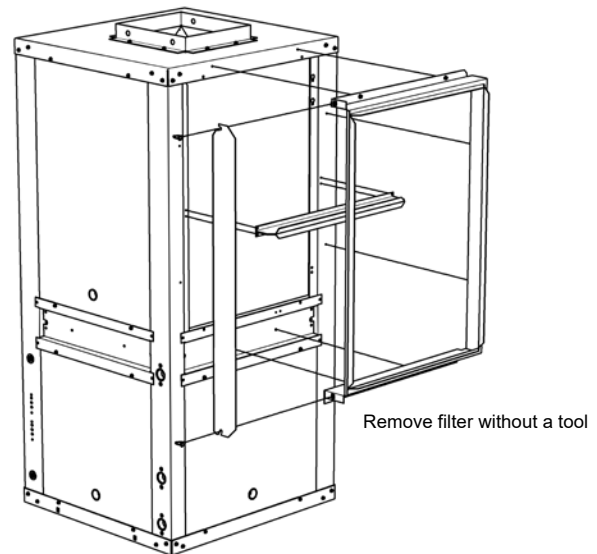

Blower Housing

The blower housing protrudes through the cabinet top allowing adequate material for connection to a flexible duct.

Figure 2: Fan housing protrudes through the cabinet top for connection of flexible duct



Electrical

The electrical components are located in the compressor section of the unit. Separate holes are provided on the cabinet to facilitate main power and low voltage control wiring. All wiring connections are made internal to the cabinet to reduce the risk of accidental contact. Each unit is rated to accept time-delay fuses for branch circuit overcurrent protection. Single phase units are also rated for use with HACR circuit breakers.

The control box houses the major operating electrical controls including the MicroTech III unit controller, transformer, compressor relay and fan relay. Each component can be accessed easily for service or replacement.

Figure 3: Easy access to the vertical unit control panel

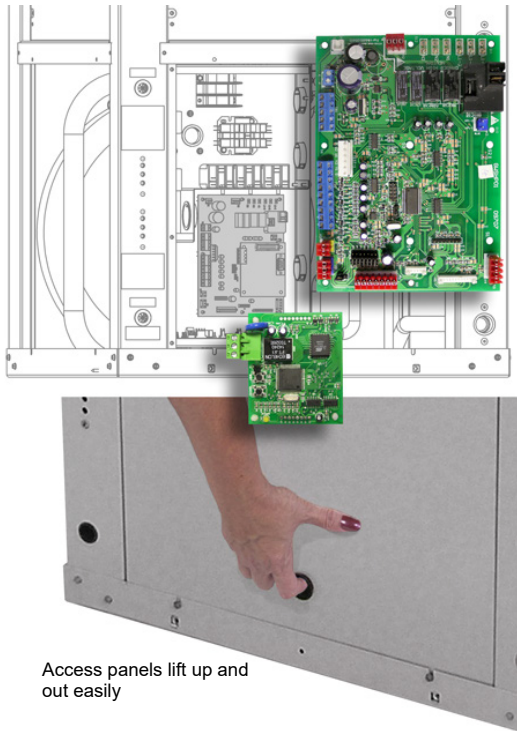

Water Connections

The water and condensate connections are FPT fittings, securely mounted flush to the corner post to allow for connection to a flexible hose without the use of a back-up wrench. This helps reduce the time required to connect the unit and helps prevent delays due to shipping damage. All vertical units are internally trapped with clear vinyl tubing, to allow inspection of condensate drain.

Figure 4: Flush FPT water fittings

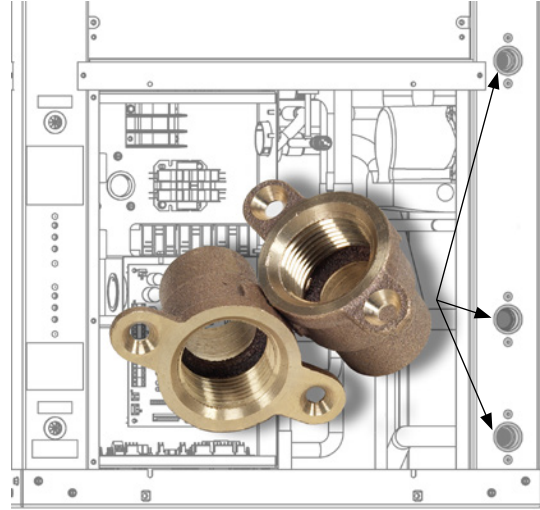

Drain Pan

Daikin vertical Enfinity heat pumps come standard with a Polypropylene (PP), corrosion-resistant plastic drain pan to promote good indoor air quality. The pan is double sloped for positive draining to reduce the occurrence of standing water and microbial growth. The drain pan also includes an internal condensate trap.

Figure 5: Internally trapped, double-sloped drain pan

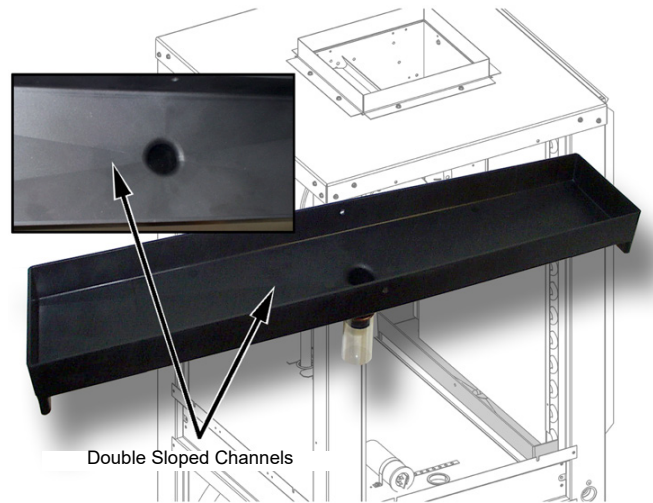

R-410A Refrigerant

- R-410A refrigerant has zero ozone depletion potential, no scheduled phase-out and is classified in ASHRAE Standard 31 as A1/A1 – lower toxicity, no flame propagation.

Compressors

Enfinity water source heat pumps are designed around the most advanced compressors in the industry. A wide variety of compressor types are used to offer the best system design for the dedicated refrigerants and tonnage. This allows Enfinity water source heat pumps to deliver rated capacity with low noise levels. Rotary compressor with R-410A is used in vertical units size 009 to 015. R-410A, non-CFC refrigerant is used in all unit sizes 009 to 070. Unit sizes 019 to 070 use a scroll compressor.

Figure 6: Compressors



Reversing Valve

A 4-way reversing valve is included with all Enfinity water source heat pumps. The valve is energized in the heating mode and will “fail-safe” to the cooling mode which is the predominant mode of operation for commercial applications.

Figure 7: 4-way reversing valve

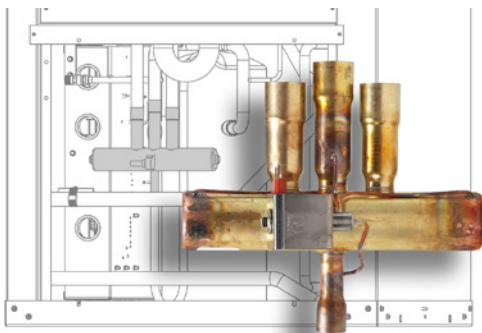

Thermal Expansion Valve

All Enfinity water source heat pump units include a thermal expansion valve for refrigerant metering. The Thermal Expansion Valve (TXV) allows the unit to operate at optimum efficiency with fluid temperatures ranging from 30°F to 110°F, and entering air temperatures ranging from 40°F to 90°F. The TXV precisely meters the exact amount of refrigerant flow through the system to meet the load and deliver rated heating and cooling capacity.

Figure 8: Thermal expansion valve (TXV)

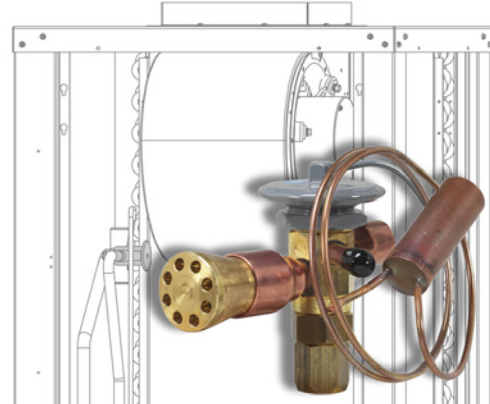

Fluid-to-Refrigerant Coil

The copper or cupronickel (optional) tube-in-tube coaxial heat exchanger used in Enfinity water source heat pumps are designed for maximum heat transfer at normal and low water flow rates with minimum pressure drop. The inner tube is deeply fluted to enhance heat transfer and minimize fouling. All coaxial coils are tested to 500 psig on the water side and 600 psig on the refrigerant side.

Geothermal range (VFW) units include coil and piping insulation to protect against condensation in low-temperature geothermal applications.

Figure 9: Coaxial heat exchanger

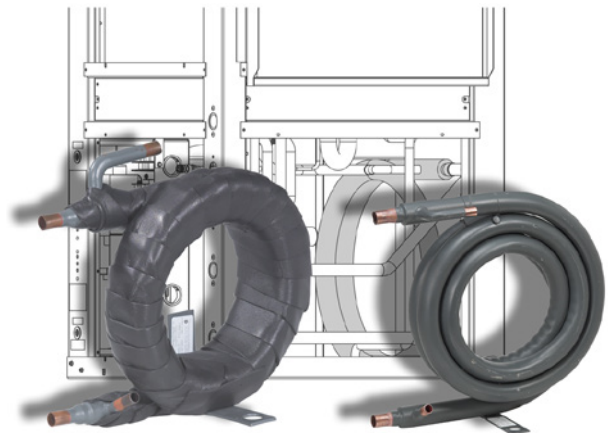

Noise Reduction

Enfinity Water Source Heat Pumps include multiple features and options to reduce unwanted noise generation including scroll and rotary compression, viscoelastic acoustic mass plate, vibration isolated fan mounts, optional compressor sound blankets and soft starting EC motors. While good design and installation practices are always required to prevent objectionable noise, Daikin, as a leader in engineered products can also provide many other customized solutions to meet your applications requirements.

CorMax® Connections

Two CorMax valves are located inside the end access panel – one on the low side and one on the high side of the refrigeration circuit – for charging and servicing. All valves are 7/16" SAE fittings.

Figure 10: CorMax valve

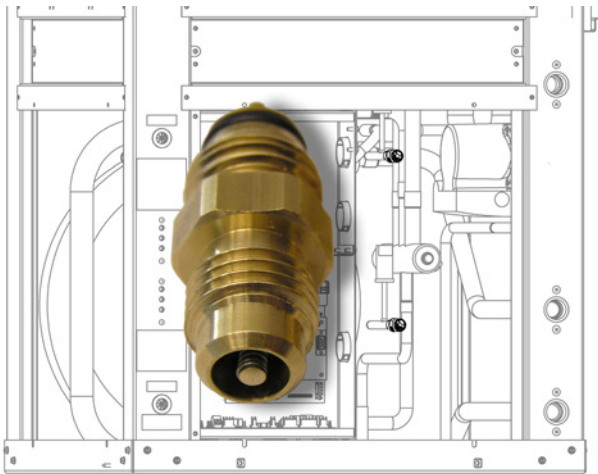

Air-to-Refrigerant Coil

The air-to-refrigerant heat exchanger is a large face area coil with copper tubes and aluminum fins. The fins are lanced and mechanically bonded to the tubes using finned edges on the inside which expand during assembly to enhance heat transfer capabilities. The maximum working pressure of the heat exchanger is 500 psig (3447 kPa). The coil is designed for optimal performance in both heating and cooling while maintaining the benefit of a compact size. Coils can be provided with an optional E-coating.

Refrigeration System

Units have a coaxial heat exchanger with a copper inner tube and a steel outer tube. The air coil is a large face area coil with copper tubes and aluminum fins. Safety controls include a high-pressure switch and low-temperature sensor to lock out compressor operation at extreme conditions. For additional protection, units have a 7 psi (48 kPa) low-pressure switch to protect the compressor from low refrigerant charge. The low setting prevents nuisance trips while providing additional protection.

Blower Section

The blower section includes the blower housing, wheel, motor and drain pan. It is separated from the compressor section by an insulated divider panel for maximum sound attenuation. The large size of the blower wheel allows it to rotate more slowly, reducing motor work to improve efficiency and provide for quiet operation. A large panel provides service access to the blower and motor. All blower/motor assemblies have a removable orifice ring on the housing to accommodate motor and blower removal without disconnecting the unit from the ductwork.

Blower Motors

The standard blower motor is a multi-speed, Permanent Split Capacitor (PSC) type with thermal overload protection. It is permanently lubricated. The motor is factory wired to maximize performance and efficiency. Unit sizes 019 and larger have a terminal strip on the motor for simple motor speed change without going back to the control box. The motor is isolated from the fan housing using rubber isolators to minimize vibration transmission. All blower/motor assemblies have a removable orifice ring on the housing to accommodate motor and blower removal without disconnecting the unit from the ductwork.

Figure 11: High efficiency blower motor options

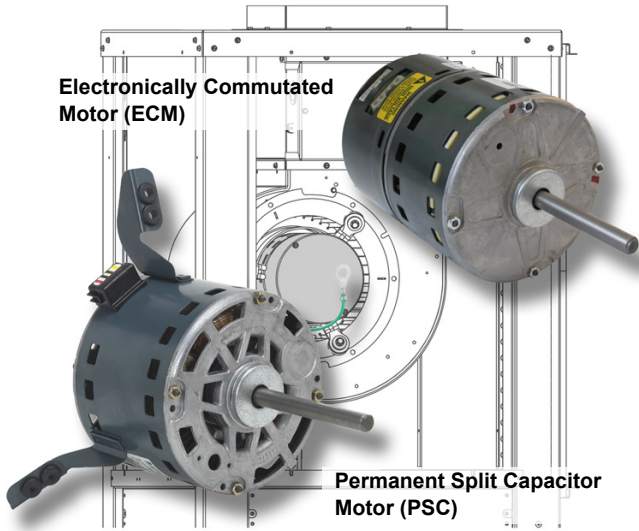

EC Constant Torque Fan Motor (Option)

The optional constant torque EC blower motor offers increased efficiencies. This motor is similar in function to a PSC, but will deliver airflow at higher external static pressures. These motors are available for sizes 009 to 012 and include a field adjustable 4-position fan speed selector switch.



Constant Torque EC Motor Sizes 009-012

EC Constant CFM Fan Motor (Option)

For unit sizes 015 – 070, the high efficiency EC constant airflow motor option provides constant airflow and economical performance over a wide static pressure range. This motor is an ideal option for high filtration applications that utilize the optional MERV-13 air filter. One of the many benefits of the EC motor is a soft start/stop feature for quiet operation. The 4-speed fan selector switch allows for quick fan speed adjustment to optimize unit performance. **NOTE:** These motors require a neutral wire for units with 460/3 electrical.

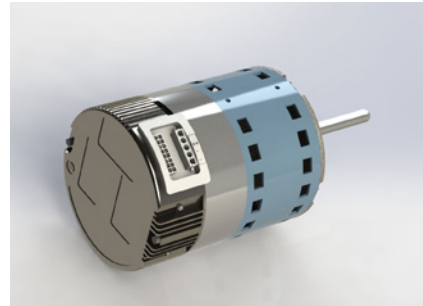

Control Choices And Added Functionality

The control box is accessible through the left or right end corner panel. It houses the major operating electrical controls including the MicroTech® III unit controller, transformer, compressor relay and fan relay. Each component is accessible for service or replacement.





Four unique control choices are offered with the MicroTech III unit controller:

- Standalone operation using a MicroTech III unit controller

- MicroTech III unit controller with I/O Expansion module
- MicroTech III unit controller with a LONWORKS® communication module
- MicroTech III unit controller with a BACnet® communication module

Each option features direct quick-connect wiring to all unit-controlled components for “clean” wiring inside the control box. Each control circuit board receives power from a 50 VA transformer.

Table 1: Control options

Control	Description	Application	Protocol
 <p>(Standalone) Unit Controller.</p>	<p>The MicroTech III unit controller is a standalone microprocessor-based control board conveniently located in the unit control box for accessibility. The board is designed to provide standalone control of a Water Source Heat Pump using a wall thermostat or a wall mounted temperature sensor. Each unit controller is factory programmed, wired, and tested.</p>	<p>Each unit controller is factory programmed, wired, and tested for complete control of single zone, standalone operation of your Daikin Water Source Heat Pump.</p>	<p>Unit-mounted or wall-mounted thermostat</p>
 <p>I/O Expansion Module</p>	<p>The I/O Expansion Module is an extension of the Microtech III unit controller and provides additional functionality to the Microtech III control system. The interconnect cable from the I/O expansion module to the MicroTech III unit controller provides two-stage operation of the water source heat pump.</p>	<p>Allows for:</p> <ul style="list-style-type: none"> • Monitoring of entering water temperature for boilerless electric heat control. • Outputs for optional electric heat • Independent LED annunciator to easily identify operation fault conditions for two-stage units. 	<p>Unit-mounted or wall-mounted thermostat</p>
 <p>LONWORKS Communication Module</p>	<p>The MicroTech III unit controller can accept a plug-in LONWORKS communication module to provide network communications and added functionality to easily integrate with an existing BAS. The communication module can be factory- or field-installed and is tested with all logic required to monitor and control the unit.</p>	<p>LONTALK application protocol is designed for units that are integrated into a LONWORKS communication network for centralized scheduling and management of multiple heat pumps.</p>	<p>LONMARK 3.4 Certified</p>
 <p>BACnet Communication Module</p>	<p>The MicroTech III unit controller can accept a plug-in BACnet communication module to provide network communications and added functionality to easily integrate with an existing BAS. The communication module can be factory- or field-installed and is tested with all logic required to monitor and control the unit.</p>	<p>Designed to be linked with a centralized building automation system (BAS) through a BACnet communications network for centralized scheduling and management of multiple heat pumps.</p>	<p>BACnet MS/TP</p>

MicroTech® III Unit Controller with LONWORKS® or BACnet® Communication Module

Each Enfinity Horizontal Water Source Heat Pump can be equipped with a LONWORKS or BACnet communication module. The LONWORKS module is LONMARK 3.4 certified and designed to communicate over a LONWORKS communications network to a Building Automation System (BAS). The BACnet module is designed to communicate over a BACnet MS/TP communications network to a building automation system. Both controllers are micro-processor-based and can be factory or field-installed. The control modules are programmed and tested with all the logic required to monitor and control the unit. Optional wall sensors may be used with the communication modules to provide limited local control of the Horizontal Water Source Heat Pump. The MicroTech III unit controller monitors water and air temperatures and passes information to the communication module. The module communicates with the BAS, to provide network control of the Water Source Heat Pump.

MicroTech III LONWORKS Communication Module

The LONWORKS communication module is designed for units that are integrated into a LONWORKS communication network for centralized scheduling and management of multiple heat pumps.

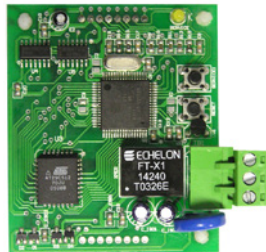

MicroTech III BACnet Communication Module

Designed to be linked with a centralized building automation system (BAS) through a BACnet communications network for centralized scheduling and management of multiple heat pumps.

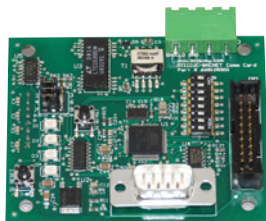

MicroTech III Unit Controller with Communication Modules Features

The MicroTech III Unit Controller with LONWORKS or BACnet Communication Module orchestrates the following unit operations:

- Enable heating and cooling to maintain space temperature setpoint based on a room sensor setting
- Enable fan and compressor operation
- Monitors all equipment protection controls
- Monitors room and discharge air temperatures
- Monitors leaving water temperature
- Relays status of all vital unit functions

An on-board status LED indicates the status of the MicroTech III LONWORKS or BACnet module.

The MicroTech III unit controller with communication module includes:

- Return Air Temperature sensor (RAT) (field-installed)
- Discharge Air Temperature sensor (DAT) (field-installed)
- Leaving Water Temperature sensor (LWT) (factory-installed)

CAUTION

When an optional wall-mounted room temperature sensor is connected to the unit controller, the Return Air Temperature (RAT) sensor must not be installed. A wall-mounted room temperature sensor and the return air temperature sensor must not be connected simultaneously or the unit will not operate properly.

The communication modules provide network access to setpoints for operational control

Available wall sensors include:

- Room sensor
- Room sensor with LED status and tenant override button
- Temperature sensor with LED status, timed-override button, and $\pm 5^{\circ}\text{F}$ setpoint adjustment
- Room sensor with LED status, timed-override button, 55° to 95°F setpoint adjustment

MicroTech® III Unit Controller

The MicroTech III Unit Controller is a microprocessor-based control board conveniently located in the unit control box for easy access through a removable access panel. The standalone unit controller is a hard wired interface and provides all the necessary field connections. The board can be wired for 24-volt AC output to the wall thermostat by using terminals R & C. An LED annunciator is located on the front corner of the unit chassis to quickly check the operating status of the unit.

MicroTech III Unit Protections & LED Fault Status Annunciation

Assumes cycle fan operation-not continuous fan operation:

- **Start-up** – The unit will not operate until all the inputs and safety controls are checked for normal conditions.
- **Cooling mode** – On a call for cooling, the compressor and fan will start after the various control timers have expired. If the reversing valve output is energized, the reversing valve output will be de-energized 5 seconds after the compressor has been energized. When the load is satisfied, the compressor and fan shut off.
- **Heating Mode** – On a call for heating, the compressor and fan start after the various control timers have expired. If the reversing valve output is de-energized, the reversing valve output will be energized 5 seconds after the compressor has been energized. When the load is satisfied, the compressor and fan shut off. The reversing valve remains energized.
- **Short Cycle Protection & Random Start** – After power cycle or deactivation of certain alarms, or when leaving the unoccupied mode, a new random compressor start-delay time between 300 and 360 seconds is generated. The random start timer prevents compressors in different units from starting simultaneously. Compressor minimum OFF 360 sec) and compressor minimum ON (180 sec) timers prevent compressor short cycling.
- **Unoccupied Mode** – A simple “grounded” signal between terminals U and C (no power source required), puts the unit into the unoccupied mode for night setback operation.
- **Override Mode** – A switch on the deluxe automatic changeover thermostat can be activated during the unoccupied mode to put the unit back into the occupied mode for two hours for after-hours heating or cooling.
- **Motorized Valve/Pump Restart** – The IV/PR (H8) terminals on the The MicroTech III unit controller are used to energize (open) a motorized valve or start a water pump to get water circulating prior to starting the compressor on call for heating or cooling. The IV/PR (H8) terminal may be “daisy chained” between 200 units.
- **Brownout Protection** – The MicroTech III unit controller measures the input voltage and will suspend compressor and fan operation if the voltage falls below 80% of the unit nameplate rated value. A unique LED status is generated and an output is available to a “fault” LED at the thermostat.
- **Unit Shutdown** – A simple grounded signal puts the unit into the shutdown mode. Compressor and fan operations are suspended. A unique LED status is generated and an output signal is made available for connection to a “fault” LED at the thermostat.
- **Condensate Overflow Protection** – The MicroTech III unit controller incorporates a liquid sensor at the top of the drain pan. Upon sensing water, cooling and dehumidification operations are suspended and an LED status is generated.
- **Remote Reset of Automatic Lockouts** – The Remote Reset feature provides the means to remotely reset some lockouts generated by high-pressure and/or low-temperature faults. When the MicroTech III unit controller is locked out due to one of these faults, and the cause of the fault condition has been cleared, energizing the O-terminal for 11 seconds or more forces the MicroTech III unit controller to clear the lockout. Cycling unit power also clears a lockout if the conditions causing the fault have been alleviated.
- **Intelligent Alarm Reset** – The Intelligent Reset feature helps to minimize nuisance trips of automatic lockouts caused by low-temperature faults in heating mode. This feature clears faults the first two times they occur within a 24-hour period and triggers an automatic lockout on the 3rd fault. The retry count is reset to zero every 24 hours.
- **Equipment Protection Control** – The MicroTech III unit controller receives separate input signals from the refrigerant high-pressure switch and the low suction line temperature sensor. In a high-pressure situation, compressor operation is suspended. In a low temperature situation during heating operation, the unit goes into a defrost cycle where the unit is put into cooling operation for 60 seconds until the coaxial heat exchanger is free of ice. Each switch generates its own unique LED status and output is available to a “fault” LED at the thermostat if either situation exists.

Note: *Most unit fault conditions are the result of operating the equipment outside the unit specifications.*

Table 2: MicroTech III controller configuration jumper settings

Baseboard Description	Jumper(s)	Setting	Model
Normal / Test Mode	JP1	JP1 = Open	Normal Operation
		JP1 = Shorted	Service / Test Mode
Fan Operation	JP2	JP2 = Open	Continuous Fan Operation (On)
		JP2 = Shorted	Cycling Fan Operation (Auto)
Loop Fluid	JP3	JP3 = Open	Water Loop Fluid
		JP3 = Shorted	Glycol Loop Fluid
Freeze Fault Protection	JP4	JP4 = Open JP4 = Shorted	Not Used
Room Sensor Setpoint Potentiometer Range	JP5	JP5 = Open	Short Range: -5 to +5 °F (-2.78 to +2.78 °C)
		JP5 = Shorted	Long Range: 55 to 95 °F (12.78 to 35 °C)
Thermostat / Room Sensor	JP6	JP6 = Open	Thermostat Control
		JP6 = Shorted	Room Sensor Control
Compressor Heating Source	JP7	JP7 = Open	Allow Compressor Heating Mode Operation
		JP7 = Shorted	Disable Compressor Heating Mode Operation
I/O Expansion Module	JP8	JP8 = Open	I/O Expansion Board Not Present
		JP8 = Shorted	I/O Expansion Board Is Required

⚠ WARNING

Proper antifreeze/water solution is required to minimize the potential of fluid freeze-up. Jumper JP3 is factory set for water freeze protection with the jumper open. Operation at fluid temperatures below 32°F with anti-freeze protection requires JP3 to be field configured for the jumper closed. If unit is employing a fresh water system (no anti-freeze protection), it is extremely important that JP3 jumper setting remains in the open position (factory default setting) in order to shut down the unit at the appropriate water temperature to protect your heat pump from freezing. Failure to do so can result in unit damage, property damage and will void unit warranty.

Table 3: I/O expansion module jumper settings

I/O Expansion Description	Jumper(s)	Setting	Model
Fan Row Select for Operating Modes: • Fan Only (with Optional ECM)	JP1 & JP2	JP1 = Open JP2 = Open	Fan Row "A" Selected
		JP1 = Shorted JP2 = Open	Fan Row "B" Selected
		JP1 = Open JP2 = Shorted	Fan Row "C" Selected
		JP1 = Shorted JP2 = Shorted	Fan Row "D" Selected
Secondary Heating Options	JP3 & JP4	JP3 = Open JP4 = Open	None
		JP3 = Shorted JP4 = Open	Supplemental Electric Heat
		JP3 = Open JP4 = Shorted	Boilerless Electric Heat
		JP3 = Shorted JP4 = Shorted	Not Used
Dehumidification Options	JP5 & JP6	JP5 = Open JP6 = Open	None
		JP5 = Shorted JP6 = Open	Hot Gas Reheat (HGR)
		JP5 = Open JP6 = Shorted	Not Used
Not Used	JP7	JP7 = Open	-
Compressor Capacity Option	JP8	JP8 = Open JP8 = Shorted	Not Used

Table 4: MicroTech III controller status LED's

Description	Type	Yellow	Green	Red
I/O Expansion Communication Fail	Fault	ON	Flash	Flash
Invalid Configuration	Fault	Flash	Flash	OFF
Low Voltage Brownout	Fault	OFF	Flash	OFF
Emergency Shutdown	Mode	OFF	Flash	OFF
Compressor High Pressure	Fault	OFF	OFF	Flash
Compressor Low Pressure	Fault	OFF	OFF	ON
Compressor Suction Temp Sensor Fail	Fault	Flash	Flash	ON
Compressor Low Suction Temp	Fault	Flash	OFF	OFF
Freeze Fault Detect	Fault	Flash	OFF	Flash
Room Temp Sensor Fail (Room Sensor Control Only)	Fault	Flash	Flash	ON
Leaving Water Temp Sensor Fail	Fault	Flash	Flash	ON
Condensate Overflow	Fault	ON	OFF	OFF
Serial EEPROM Corrupted	Fault	ON	ON	ON
Service Test Mode Enabled	Mode	Flash	Flash	Flash
Unoccupied Mode	Mode	ON	ON	OFF
Occupied, Bypass, Standby, or Tenant Override Modes	Mode	OFF	ON	OFF

Table 5: I/O expansion module fault & status LED's

Description	Type	Yellow	Green	Red
Baseboard Communication Fail	Fault	Flash	OFF	Flash
Entering Water Temp Sensor Fail (Boilerless Electric Heat)	Fault	ON	OFF	Flash
Low Entering Water Temperature (No Display On Boilerless Electric Heat)	Fault	OFF	ON	Flash
Fan is OFF	Mode	OFF	ON	OFF
Fan Running at Low Speed (0 to 33%) Duty Cycle	Mode	OFF	Flash	OFF
Fan Running at Medium Speed (34 to 66%) Duty Cycle	Mode	ON	Flash	OFF
Fan Running at High Speed (67 to 100%) Duty Cycle	Mode	Flash	Flash	OFF

Notes: 1. Mode / faults are listed in order of priority.

2. I/O expansion module supplied with boilerless and supplemental electric heat options.

I/O Expansion Module

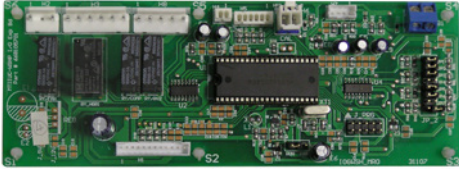

The I/O Expansion Module is a factory installed option. It is an extension of the MicroTech III unit controller and provides extra functionality.

The I/O Expansion Module has 4 main purposes:

- The I/O Expansion Module has outputs to control boilerless electric or secondary heating option on a standard Water Source Heat Pump.
- The I/O Expansion Module has outputs for multi-speed fans on a standard Water Source Heat Pump.
- The I/O Expansion Module has an independent LED annunciator to identify operational fault conditions on dual-circuit equipment.

Figure 12: I/O expansion module configuration jumper terminals

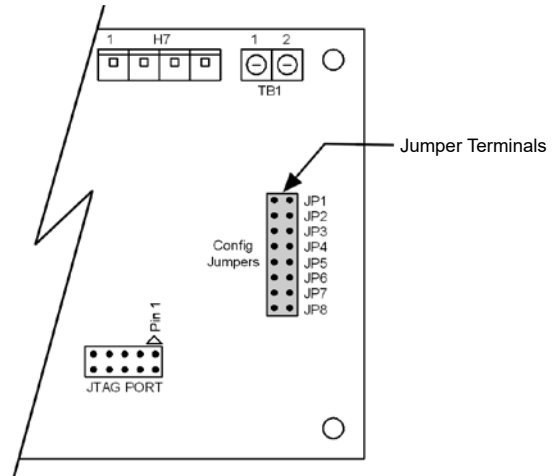

Features

Standard Heat Pumps / Single Circuit Units

- Monitors entering water temperature for boilerless electric heat control
- Outputs for medium and high speed fan controls.

Typical Cooling and Heating Refrigeration Cycles

(For standard heat pump operation only)

Figure 13: Cooling refrigeration cycle

When the wall thermostat calls for COOLING, the reversing valve directs the flow of the refrigerant, a hot gas, from the compressor to the water-to-refrigerant heat exchanger. There, the heat is removed by the water, and the hot gas condenses to become a liquid. The liquid then flows through a thermal expansion valve to the air-to-refrigerant heat exchanger coil. The liquid then evaporates and becomes a gas, at the same time absorbing heat and cooling the air passing over the surfaces of the coil. The refrigerant then flows as a low pressure gas through the reversing valve and back to the suction side of the compressor to complete the cycle.

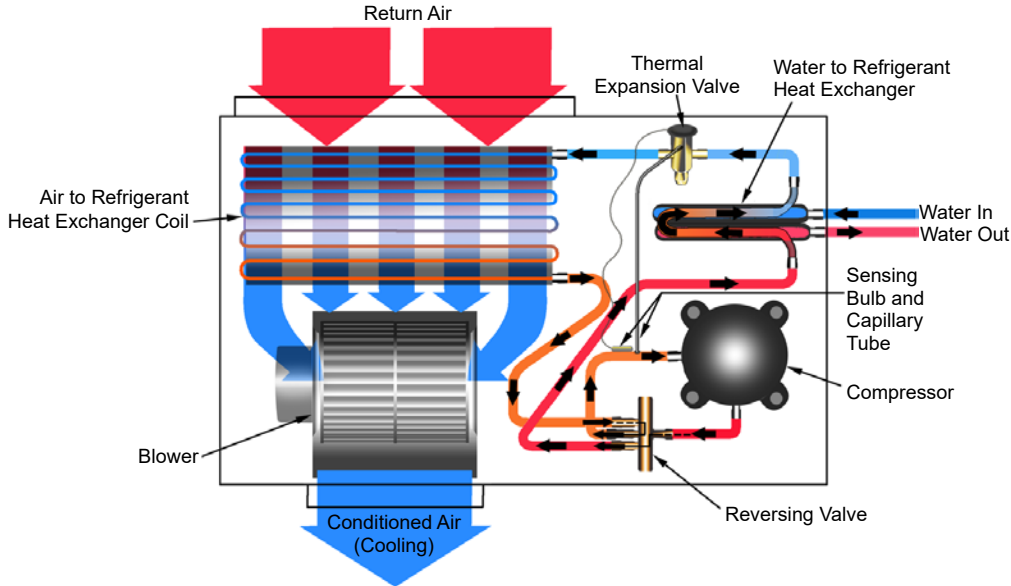
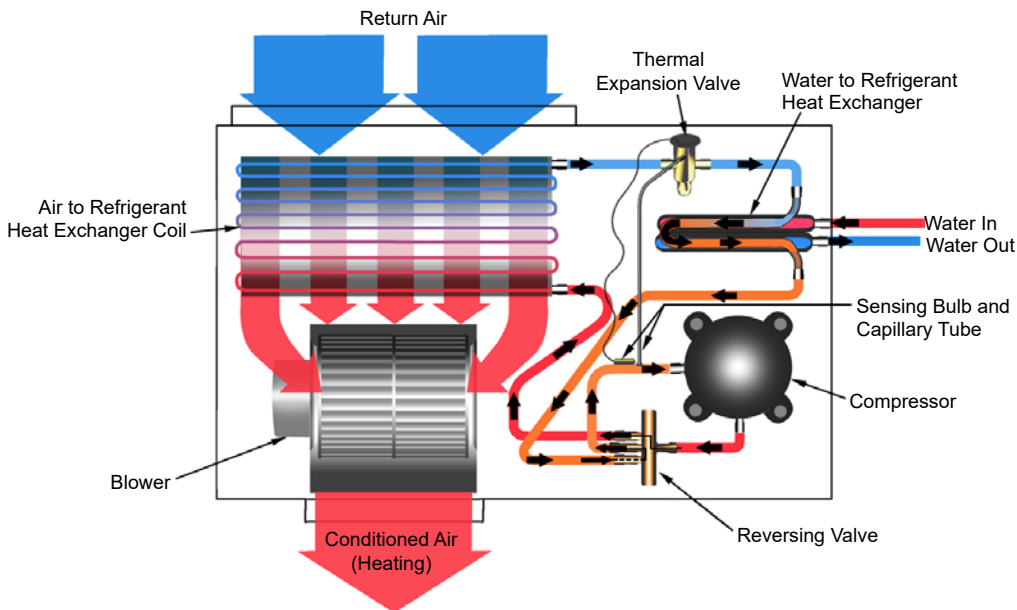

Figure 14: Heating refrigeration cycle

When the wall thermostat calls for HEATING, the reversing valve directs the flow of the refrigerant, a hot gas, from the compressor to the air-to-refrigerant heat exchanger coil. There, the heat is removed by the air passing over the surfaces of the coil and the hot gas condenses and becomes a liquid. The liquid then flows through a thermal expansion valve to the water-to-refrigerant heat exchanger. The liquid then evaporates and becomes a gas, at the same time absorbing heat and cooling the water. The refrigerant then flows as a low pressure gas through the reversing valve and back to the suction side of the compressor to complete the cycle.



Systems

Water source heat pump systems are one of the most efficient, environmentally friendly systems available for heating and cooling buildings. High-efficiency, self contained units (sizes 7,000 btuh to 420,000 btuh) can be placed in virtually any location within a building. Each unit responds only to the heating or cooling load of the individual zone it serves. This permits an excellent comfort level for occupants, better control of energy use for building owners and lower seasonal operating costs. The Air-Conditioning Refrigeration Institute (ARI) and the International Standards Organization (ISO) publish standards so that water source heat pumps are rated for specific applications. The ARI/ISO loop options shown in this catalog are typical water source heat pump loop choices available in today's market. These systems offer benefits ranging from low cost installation to the highest energy efficiency available in the market today.

Boiler / Tower Applications: ISO 13256-1

A "Boiler/Tower" application uses a simple two-pipe water circulating system that adds heat, removes heat or transfers rejected heat to other units throughout the building. The water temperature for heating is generally maintained between 65°F – 70°F and is usually provided by a natural gas or electric boiler located in a mechanical room. The condensing water temperature, during cooling months, is maintained between 85°F and 95°F and requires the use of a cooling tower to dissipate waste heat. Cooling towers can be located on the roof, or inside or adjacent to the building. This application can be the lowest cost of the loop options available.

Note: ASHRAE 90.1 standards require that circulating pumps over 10 HP will require use of "variable frequency drive" equipment and pipe insulation to be used whenever water temperatures are below 60 degrees and above 105 degrees. See ASHRAE 90.1 Standards for details.

Figure 15: Boiler/tower application

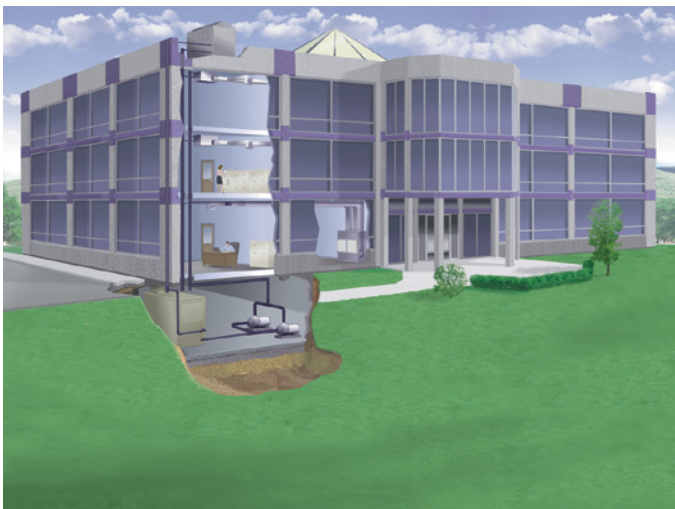

Open Loop Well Water Applications: ISO 13256-1

"Open Loop" well water systems use ground water to remove or add heat to the interior water loop. The key benefit of an open loop system is the constant water temperature, usually 50°F to 60°F, which provides efficient operation at a low first cost. Most commercial designers incorporate a heat exchanger to isolate the building loop from the well water. Using heat exchangers can reduce maintenance issues while still allowing the transfer of heat from unit to unit as with the "Boiler/Tower System". A successful design provides an ample amount of groundwater (approximately 2 GPM per ton) and adequate provisions for discharging water back to the aquifer or surface. Open Loop applications are commonly used in coastal areas where soil characteristics allow reinjection wells to return the water back to the aquifer. Note that some states have requirements on the depths of return water reinjection wells, and such wells must be approved by the United States Environmental Protection Agency. Also, bad water quality can increase problems with heat exchanger scaling. Suspended solids can erode the heat exchanger. Strainers can be used to contain suspended solids.

Figure 16: Open loop well application

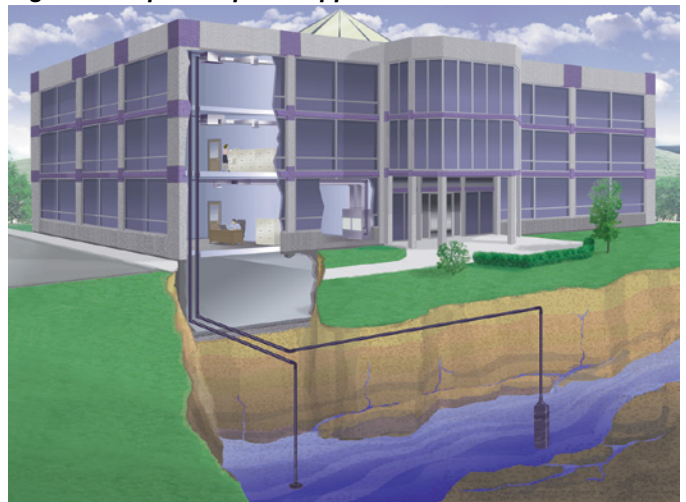

Closed Loop Geothermal Applications AHRI ISO 13256-1

“Vertical Closed Loop” applications are installed by drilling vertical bore holes into the earth and inserting a plastic polyethylene supply/return pipe into the holes. The vertical wells are connected in parallel reverse return fashion to allow the water from the building to circulate evenly throughout the borefield. The circulating fluid dissipates heat to the ground in a similar manner as a “tower” and adds heat back to the loop like a boiler. If properly designed, the loop field can maintain the loop temperatures necessary to condition the building without the use of a boiler or a tower. Loop temperatures usually range from 37°F to 95°F in Northern climates. Southern applications can see temperatures ranging from 40°F to 100°F. The number of bore holes and their depth should be determined by using commercial software that is specifically designed for vertical geothermal applications. Typical bore depths of a vertical loop range from 150 to 400 feet and generally require about 250 feet of surface area per ton of cooling.

Figure 17: Vertical loop application



A closed loop “Horizontal” geothermal application is similar to a vertical loop application with the exception that the loops are installed in trenches approximately 5 feet below the ground surface. The piping may be installed using a “four-pipe” or “six-pipe” design and could require 1,500 to 2,000 square feet of surface area per ton of cooling. Loop temperatures for a commercial application can range from 35°F to 95°F in Northern climates. Southern climates can see temperatures ranging from 40°F to 100°F. Horizontal loops are generally not applied in urban areas because land use and costs can be prohibitive. New advances in installation procedures have improved the assembly time of horizontal loops while keeping the first cost lower than a vertical loop.

Figure 18: Horizontal loop application

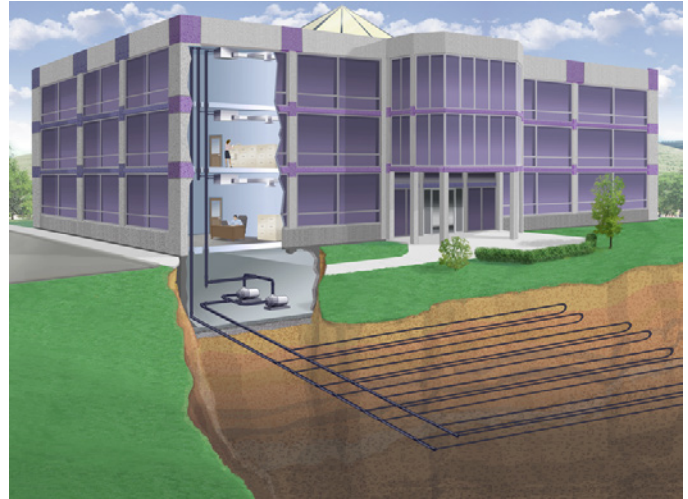

A “Surface Water” or “Lake” closed loop system is a geothermal loop that is directly installed in a lake or body of water that is near the building. In many cases, the body of water is constructed on the building site to meet drainage or aesthetic requirements. Surface loops use bundled polyethylene coils that are connected in the same manner as a vertical or horizontal loop using a parallel reverse return design. The size and the depth of the lake is critical. Commercial design services should be used to certify that a given body of water is sufficient to withstand the building loads. Loop temperatures usually range from 35°F to 90°F and prove to be the best cooling performer and lowest cost loop option of the three geothermal loops. Some applications may not be good candidates due to public access or debris problems from flooding.

Figure 19: Surface water loop application



Application Considerations

Unit Location

The VFC, VFW water source heat pump can be installed “free standing” in an equipment room; however, closet installations are more common for the small vertical type units. Generally, the unit is located in the corner of a closet with the non-ducted return air facing 90 degrees to the door and the major access panels facing the door as shown in the illustration at right. Alternatively, the unit can have a ducted return air with the opening facing the door and the major access panels facing 90 degrees to the door.

Locate a vertical unit to allow for easy removal of the filter and access panels. Allow a minimum of 18" (46 cm) clearance on each side of the unit for service and maintenance access. Always be sure to leave at least one side of the filter rack unobstructed so that the service personnel will be able to slide the filter out.

Install a field supplied line voltage disconnect for branch circuit protection.

To reduce noise emissions, install a field-provided 1/2 inch thick, isolator pad below the entire base of the vertical unit. The pad should be equal to the overall foot-print size of the unit to provide sound dampening of the unit while in operation.

Figure 20: Typical closet installation - non-ducted application

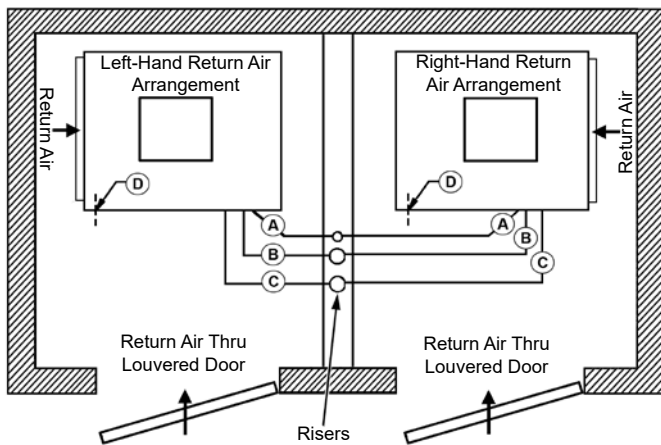

- A** Condensate
- B** Water Return
- C** Water Supply
- D** Low Voltage Control Wiring (Electric Entrance)

Figure 21: Typical VFC installation – closet, non-ducted return

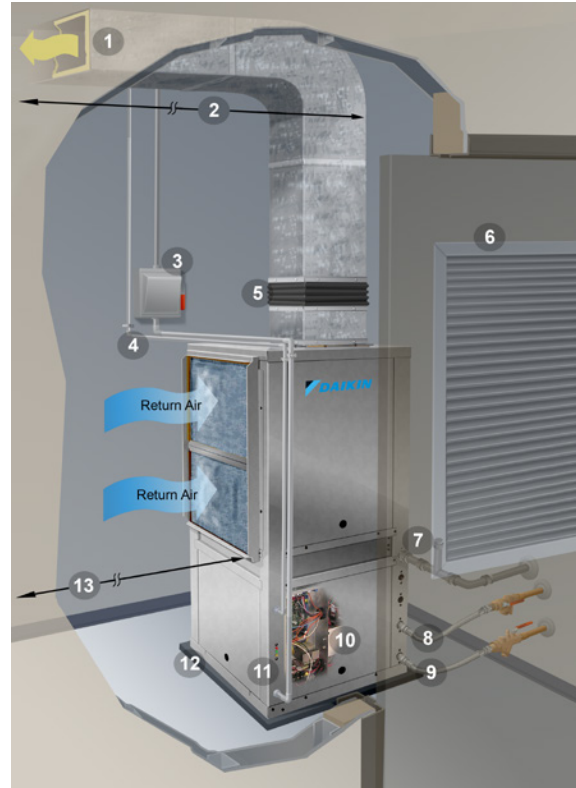

1. Discharge air
2. Acoustic thermal duct lining - 10 feet
3. Low voltage wiring to unit control box
4. Line voltage disconnect
5. Flexible duct collar
6. Louvered closet door
7. Condensate drain
8. Flexible, braided, stainless steel return hose with flow controller/ball valve with port
9. Flexible, braided, stainless steel supply hose with Y-strainer/ball valve with port
10. Access to unit control box
11. LED annunciator lights indicate unit operation status and faults
12. Full vibration isolation pad between unit and floor
13. Minimum distance between return air duct collar and wall for non-ducted return applications
 - Size 009-012 – 5 inches
 - Size 015-024 – 5 inches
 - Size 030-036 – 6 inches
 - Size 042-048 – 8 inches
 - Size 060-070 – 10 inches

Ductwork and Attenuation

All ductwork should conform to industry standards of good practice as described in ASHRAE Systems Guide. The discharge duct system will normally consist of a flexible connector at the unit, a non-insulated transition piece to the full duct size, a short run of duct, an elbow without vanes, and a trunk duct teeing into a branch circuit with discharge diffusers as illustrated below. Return air ducts can be brought in through a wall grille and then to the unit. The return duct system will normally consist of a flexible connector at the unit and a trunk duct to the return air grille. With metal duct material, the return air duct should be internally lined with acoustic insulation for sound attenuation. Return air ductwork to the unit requires the optional return air duct collar/2" (51mm) filter rack kit.

Figure 22: Suggested discharge air ducting

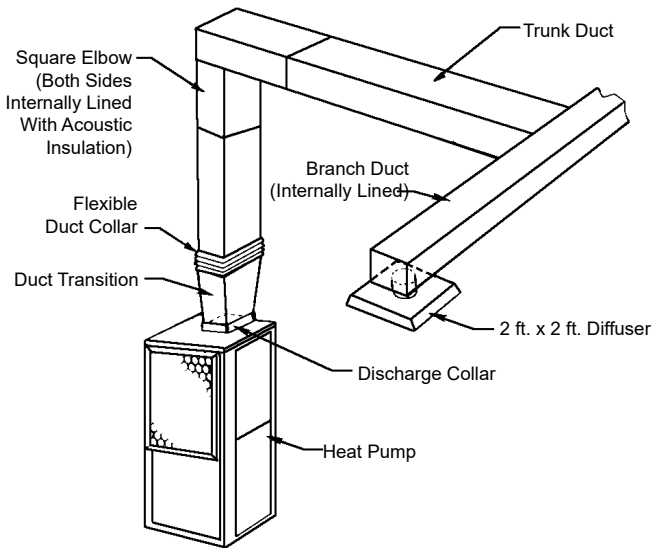

Piping

The water source heat pump unit is typically connected to the supply / return piping using a "reverse return" piping system which includes a flow control device so that flow requirements are met for each zone. A short, high pressure "flexible hose" is used to connect the unit to the building's hard piping and acts as a sound attenuator for both the unit operating noise and hydronic pumping noise. One end of the hose has a swivel fitting to facilitate removal of the unit for replacement or service. Include supply and return shutoff valves in the design to allow removal of a unit without the need to shut down the entire heat pump system. The return valve may be used for balancing and will typically have a "memory stop" so that it can be reopened to the proper position for the flow required. Fixed flow devices are commercially available and can be installed to eliminate the need for memory stop shut off valves. Include Pressure / Temperature ports to allow the service technician to measure water flow and unit operation.

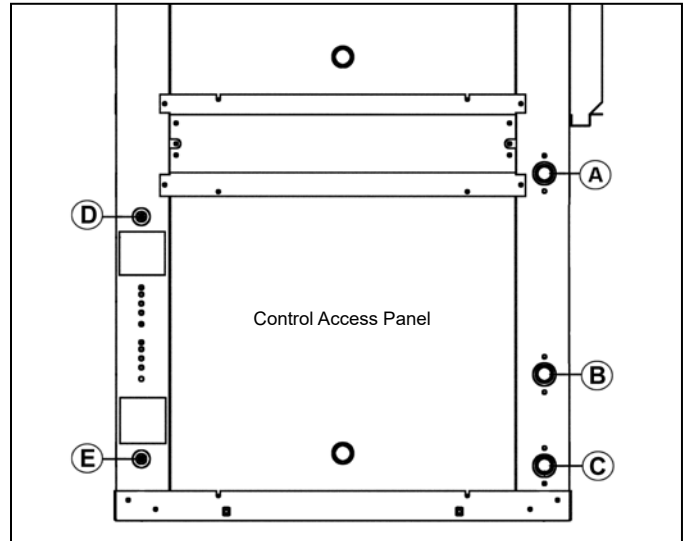

- A Condensate
- B Water Return
- C Water Supply
- D Line Voltage Unit Power (Electric Entrance)
- E Low Voltage Control Wiring (Electric Entrance)

Daikin has available optional hose kit combinations to better facilitate system flow balancing. These flexible hoses reduce vibration between the unit and the rigid piping system.

Figure 23: Fire rated supply or return hoses

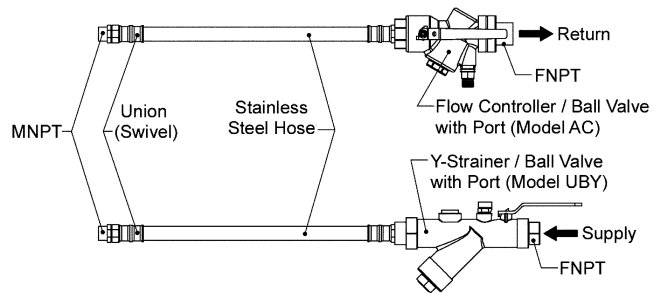

Condensate Drain

Units include a double-sloped drain pan with an internal condensate trap. Condensate removal piping must be pitched away from the unit not less than 1/4" per foot. A vent is required after the trap so that the condensate will drain away from the unit. The vent can also act as a clean out if the trap becomes clogged. To avoid having waste gases entering the building, the condensate drain should not be directly piped to a drain/waste/vent stack. See local codes for the correct application of condensate piping to drains.

Unit Selection

Achieving optimal performance with water source heat pump systems requires both accurate system design and proper equipment selection. Use a building load program to determine the heating and cooling loads of each zone prior to making equipment selections. With this information, the Daikin SelectTools™ software selection program for Water Source Heat Pumps can be used to provide fast, accurate and complete selections of all Daikin water source heat pump products. SelectTools software is available by contacting your local Daikin Representative. While we recommend that you use Daikin SelectTools software for all unit selections, manual selections can be accomplished using the same zone load information and the capacity tables available in this catalog.

Boiler / Tower Application Manual Selections:

The following example illustrates a typical selection for a zone in a boiler/tower system for a commercial building. A building load program determines that this zone needs 38,255 Btuh of total cooling, 31,832 Btuh of sensible cooling and 36,988 Btuh of total heating. The water temperatures for the boiler/tower system are 90°F for cooling and 70°F for heating. The return air temperature is 80°F dry bulb with 67°F wet bulb for cooling and 70°F for heating.

Zone Requirements:

Total Cooling Load	=	38,255 BTUH
Sensible Cooling Load	=	31,832 BTUH
Total Heating Load	=	36,988 BTUH
Air Flow Required	=	1510 CFM
Return Air Cooling	=	80°FDB/ 67°FWB
Return Air - Heating	=	70°FDB

Since a Model VFC 036 produces approximately 36,000 Btuh of cooling, it is not sufficient for this zone and a model VFC 042 should be considered. Model VFC is chosen because it is specifically designed for a boiler/ tower application. Typical water flow rates for boiler/ tower applications are 2.0 to 2.5 GPM per ton and in this example no antifreeze is used.

Selection:

ModelVFC 042 (Boiler / Tower model)

Total Cooling Capacity @ 90 EWT = 40,816 Btuh
 Sensible cooling capacity @ 90 EWT = 32,704 Btuh
 Total Heating Capacity @ 70 EWT = 52,019 Btuh
 CFM = 1510 @ .5 ESP (Wet Coil)
 Water Flow required to meet capacity = 8 GPM
 Water Pressure drop = 6.9 (FT. H2O)

Final SelectionVFC 042

Geothermal Applications:

The following example illustrates the same zone in a geothermal application.

The load requirements for the zone are the same as the above example – 38,255 Btuh of total cooling and 31,832 Btuh of sensible cooling and 36,988 Btuh of heating.

Geothermal loop software programs are available to help determine the size of the loop field based on:

- Desired entering water temperatures for the system.
- Specific acreage available for the loop which produces specific min./max loop temps for the unit selection.

Entering water temperatures for geothermal systems can be as high as 90° to 100°F and as low as 30°F based on the geographical location of the building. Water flow rates are typically 2.5 to 3 GPM per ton and the use of antifreeze is required in most northern applications.

Zone Requirements:

Total Cooling Load	=	38,255 Btuh
Sensible Cooling Load	=	31,832 Btuh
Total Heating Load	=	36,988 Btuh
Air Flow Required	=	1510 CFM
Return Air Cooling	=	80 DB / 67 WB
Return Air - Heating	=	70 DB

A Model VFW is chosen for this geothermal application. Model VFW offers insulated water piping for condensation considerations and a different freezestat setting to allow entering water temperatures lower than 40°F (with antifreeze). Output capacities should be recalculated using the "Antifreeze Correction Factors" tables shown on page 26. The Model VFW 042 is first considered but may not meet the heating load because of the reduced entering water temperatures (35°F) and an antifreeze solution of 21% propylene (see page 26).

Selection:

Model.....VFW 042 (Geothermal model)

Total cooling capacity @ 100 EWT = 40,434 Btuh x .980 = 39,625
 Sensible cooling capacity @ 100 EWT = 32,164 Btuh x .980 = 31,520

Total heating capacity @ 35 EWT = 38,335 Btuh x .975 = 37,377
 CFM = 1510 @ .6 ESP (Dry Coil)

Water Flow required to meet capacity = 10.8 GPM

Water Pressure drop = 12.7 x 1.5 = 14.61 (FT. H2O)

Final SelectionVFW 042

Notes: In applications where the zone may be a corner office or have excessive glass area, the heating load could be greater than the heating output capacity of the VFW 042 model (say 41,985 Btuh). The choices are to up-size the unit to the next model available (048), or add an electric duct heater to supplement the output of the 042 unit.

Water Loop Performance Data – Rated in Accordance with ISO Standard 13256-1 Boiler/Tower.

Air Limits

Table 6: Air limits in °F (°C)

Air Limits	Standard Range Units		Geothermal Range Units	
	Cooling	Heating	Cooling	Heating
Minimum Ambient Air ¹	50°F (10°C)	50°F (10°C)	40°F (4°C)	40°F (4°C)
Maximum Ambient Air ²	100°F/77°F (38°C/25°C)	85°F (29°C)	100°F/77°F (38°C/25°C)	85°F (29°C)
Minimum Entering Air ¹	65°F/55°F (18°C/13°C)	50°F (10°C)	65°F/55°F (18°C/13°C)	50°F (10°C)
Common Design Entering Air	75°F/63°F (24°C/17°C)	70°F (21°C)	75°F/63°F (24°C/17°C)	70°F (21°C)
Maximum Entering Air ²	85°F/71°C (29°C/22°C)	80°F (27°C)	85°F/71°C (29°C/22°C)	80°F (27°C)

Fluid Limits

Table 7: Fluid limits

Fluid Limits	Standard Range Units		Geothermal Range Units	
	Cooling	Heating	Cooling	Heating
Minimum Entering Fluid	55°F (13°C)	55°F (13°C)	30°F (-1°C)	20°F (-6°C)
Common Design Entering Fluid	85-90°F (29-32°C)	70°F (21°C)	90°F (32°C)	35-60°F (1.5-16°C)
Maximum Entering Fluid	110°F (43°C)	90°F (32°C)	110°F (43°C)	90°F (32°C)
Minimum GPM/Ton	1.5			
Nominal GPM/Ton	3.0			
Maximum GPM/Ton	4.0			

Notes: 1. Maximum and minimum values may not be combined. If one value is at maximum or minimum, the other two conditions may not exceed the normal condition for standard units. Geothermal range units may combine any two maximum conditions, but not more than two, with all other conditions being normal conditions.

2. This is not a normal or continuous operating condition. It is assumed that such a start-up is for the purpose of bringing the building space up to occupancy temperature.

Environment

This equipment is designed for indoor installation only. Sheltered locations such as attics, garages, etc., generally will not provide sufficient protection against extremes in temperature and/or humidity, and equipment performance, reliability, and service life may be adversely affected.

Power Supply

A voltage variation of +/-10% of nameplate voltage is acceptable. Three-phase system imbalance shall not exceed 2%.

Additional Information for Initial Start-Up Only

Standard Range Units:

Units are designed to start in an ambient of 50°F (10°C), with entering air at 50°F (10°C), with entering water at 70°F (21°C), with both air and water at the flow rates used in the ISO 13256-1 rating test, for initial start-up in winter.

Note: This is not a normal or continuous operating condition. It is assumed that such a start-up is for the purpose of bringing the building space up to occupancy temperature.

Geothermal Range Units:

Geothermal range heat pump conditioners are designed to start in an ambient of 40°F (5°C), with entering air at 40°F (5°C), with entering water at 40°F (5°C), with both air and water at the flow rates used in the ISO 13256-1 rating test, for initial start-up in winter.

Note: This is not a normal or continuous operating condition. It is assumed that such a start-up is for the purpose of bringing the building space up to occupancy temperature.

Airflow Correction Factors – Units with PSC Motor

Table 8: Airflow correction factors

	Percent of Nominla Airflow						
	85%	90%	95%	100%	105%	110%	115%
Total Cooling Capacity	0.981	0.987	0.994	1.000	1.006	1.013	1.019
Sensible Cooling Capacity	0.924	0.948	0.973	1.000	1.028	1.058	1.090
kW - Cooling	0.964	0.976	0.988	1.000	1.013	1.026	1.039
Total Heat of Rejection	0.980	0.987	0.993	1.000	1.007	1.014	1.021
Total Heating Capacity	0.991	0.994	0.997	1.000	1.003	1.006	1.009
kW - Heating	1.004	1.003	1.001	1.000	0.999	0.998	0.997
Total Heat of Absorption	0.991	0.994	0.997	1.000	1.003	1.006	1.009

Antifreeze Correction Factors

Table 9: Ethylene glycol

	10%	20%	30%	40%	50%
Cooling Capacity	0.9950	0.9920	0.9870	0.9830	0.9790
Heating Capacity	0.9910	0.9820	0.9770	0.9690	0.9610
Pressure Drop	1.0700	1.1300	1.1800	1.2600	1.2800

Table 10: Propylene glycol

	10%	20%	30%	40%	50%
Cooling Capacity	0.9900	0.9800	0.9700	0.9600	0.9500
Heating Capacity	0.9870	0.9750	0.9620	0.9420	0.9300
Pressure Drop	1.0700	1.1500	1.2500	1.3700	1.4200

Table 11: Methanol

	10%	20%	30%	40%	50%
Cooling Capacity	0.9980	0.9720	–	–	–
Heating Capacity	0.9950	0.9700	–	–	–
Pressure Drop	1.0230	1.0570	–	–	–

Table 12: Ethanol

	10%	20%	30%	40%	50%
Cooling Capacity	0.9910	0.9510	–	–	–
Heating Capacity	0.9950	0.9600	–	–	–
Pressure Drop	1.0350	0.9600	–	–	–

Unit with PSC Motor – without Options

Table 13: 009 - 070

Unit Size	Voltage/Hz/ Phase	Compressor		PSC Fan Motor FLA	Total Unit FLA	Minimum Voltage	Minimum Circuit Amps	Maximum Fuse or HACR Breaker Size
		RLA	LRA					
009	115/60-1	8.0	50.0	2.1	10.1	104	12.1	20
	208/230-60-1	3.7	22.0	1.0	4.7	197	5.6	15
	265/277-60-1	3.5	22.0	0.7	4.2	240	5.1	15
012	115/60-1	9.5	50.0	2.1	11.6	104	14.0	20
	208/230-60-1	4.7	25.0	1.0	5.7	197	6.9	15
	265/277-60-1	4.2	22.0	0.7	4.9	240	6.0	15
015	208/230-60-1	5.6	29.0	1.0	6.6	197	8.0	15
	265/277-60-1	5.0	28.0	1.0	6.0	240	7.2	15
019	208/230-60-1	9.0	48.0	1.0	10.0	197	12.3	20
	265/277-60-1	7.1	43.0	1.0	8.1	240	9.8	15
024	208/230-60-1	13.5	58.3	1.0	14.5	197	17.9	30
	208/230/-60-3	7.1	55.4	1.0	8.1	197	9.9	15
	265/277-60-1	9.0	54.0	1.0	10.0	240	12.2	20
	460-60-3	3.5	28.0	0.8	4.3	416	5.2	15
030	208/230-60-1	14.1	73.0	3.0	17.1	197	20.6	30
	208/230-60-3	8.9	58.0	3.0	11.9	197	14.1	20
	265/277-60-1	11.2	60.0	2.6	13.8	240	16.6	25
	460-60-3	4.2	28.0	1.5	5.7	416	6.8	15
036	208/230-60-1	17.9	112.0	3.0	20.9	197	25.4	40
	208/230-60-3	13.2	88.0	3.0	16.2	197	19.5	30
	460-60-3	6.0	44.0	1.5	7.5	416	9.0	15
042	208/230-60-1	19.9	109.0	3.8	23.7	197	28.7	45
	208/230-60-3	13.6	83.1	3.8	17.4	197	20.8	30
	460-60-3	6.1	41.0	2.4	8.5	416	10.0	15
	575-60-3	4.2	33.0	1.7	5.9	520	7.0	15
048	208/230-60-1	21.8	117.0	3.8	25.6	197	31.1	50
	208/230-60-3	13.7	83.1	3.8	17.5	197	20.9	30
	460-60-3	6.2	41.0	2.4	8.6	416	10.1	15
	575-60-3	4.8	33.0	1.7	6.5	520	7.7	15
060	208/230-60-1	26.3	134.0	3.8	30.1	197	36.7	60
	208/230-60-3	15.6	110.0	3.8	19.4	197	23.3	35
	460-60-3	7.8	52.0	2.4	10.2	416	12.1	15
	575-60-3	5.8	38.9	1.7	7.5	520	9.0	15
070	208/230-60-3	22.4	149.0	3.8	26.2	197	31.8	50
	460-60-3	10.6	75.0	2.4	13.0	416	15.6	25
	575-60-3	7.7	54.0	1.7	9.4	520	11.4	15

Unit with EC Motor – without Options

Table 14: 009 - 070

Unit Size	Voltage/Hz/ Phase	Compressor		ECM Fan Motor FLA	Total Unit FLA	Minimum Voltage	Minimum Circuit Amps	Maximum Fuse or HACR Breaker Size
		RLA	LRA					
009	115/60-1	8.0	50.0	1.75	9.8	197	11.8	15
	208/230-60-1	3.7	22.0	0.94	4.6	197	5.6	15
012	115/60-1	9.5	50.0	1.75	11.3	197	13.6	20
	208/230-60-1	4.7	25.0	0.94	5.6	197	6.8	15
015	208/230-60-1	5.6	29.0	2.8	8.4	197	9.8	15
	265/277-60-1	5.0	28.0	2.4	7.4	197	8.7	15
019	208/230-60-1	9.0	48.0	2.8	11.8	197	14.1	20
	265/277-60-1	7.1	43.0	2.4	9.5	240	11.3	15
024	208/230-60-1	13.5	58.3	2.8	16.3	197	19.7	30
	208/230-60-3	7.1	55.5	2.8	9.9	197	11.7	15
	265/277-60-1	9.0	54.0	2.4	11.4	240	13.7	20
	460-60-3	3.5	28.0	2.6	6.1	416	7.0	15
030	208/230-60-1	14.1	73.0	4.3	18.4	197	21.9	35
	208/230-60-3	8.9	58.0	4.3	13.2	197	15.4	20
	265/277-60-1	11.2	60.0	4.1	15.3	240	18.1	25
	460-60-3	4.2	28.0	4.1	8.3	416	9.4	15
036	208/230-60-1	17.9	112.0	4.3	22.2	197	26.7	40
	208/230-60-3	13.2	88.0	4.3	17.5	197	20.8	30
	460-60-3	6.0	44.0	4.1	10.1	416	11.6	15
042	208/230-60-1	19.9	109.0	6.8	26.7	197	31.7	50
	208/230-60-3	13.6	83.1	6.8	20.4	197	23.8	35
	460-60-3	6.1	41.0	5.5	11.6	416	13.1	15
048	208/230-60-1	21.8	117.0	6.8	28.6	197	34.1	50
	208/230-60-3	13.7	83.1	6.8	20.5	197	23.9	35
	460-60-3	6.2	41.0	5.5	11.7	416	13.3	15
060	208/230-60-1	26.3	134.0	9.1	35.4	197	42.0	60
	208/230-60-3	15.6	110.0	9.1	24.7	197	28.6	40
	460-60-3	7.8	52.0	6.9	14.7	416	16.7	20
070	208/230-60-3	22.4	149.0	9.1	31.5	197	37.1	50
	460-60-3	10.6	75.0	6.9	17.5	416	20.2	30

Notes: EC motors on 460/60/3 volt units require a 265 volt power supply. Both a hot AND a neutral wire are required to obtain proper fan motor voltage. Therefore, 4-wires with a wye type wiring arrangement is required.

Unit with PSC Motor – 10kW Electric Heat Coil

Table 15: 019 - 070

Unit Size	Voltage/Hz/ Phase	Compressor		PSC Fan Motor FLA	Electric Heater RLA	Total Unit FLA	Minimum Voltage	Minimum Circuit Amps	Maximum Fuse or HACR Breaker Size
		RLA	LRA						
019	208/230-60-1	9.0	48.0	1.0	40.0	41.0	197	51.3	60
	265/277-60-1	7.1	43.0	1.0	34.7	35.7	240	44.6	45
024	208/230-60-1	13.5	58.3	1.0	40.0	41.0	197	51.3	60
	208/230/-60-3	7.1	55.4	1.0	23.1	24.1	197	30.1	35
	265/277-60-1	9.0	54.0	1.0	34.7	35.7	240	44.6	45
030	208/230-60-1	14.1	73.0	3.0	40.0	43.0	197	53.8	60
	208/230-60-3	8.9	58.0	3.0	23.1	26.1	197	32.6	35
	265/277-60-1	11.2	60.0	2.6	34.7	37.3	240	46.6	50
036	208/230-60-1	17.9	112.0	3.0	40.0	43.0	197	53.8	60
	208/230-60-3	13.2	88.0	3.0	23.1	26.1	197	32.6	35
	460-60-3	6.0	44.0	1.5	11.6	13.1	416	16.4	20
042	208/230-60-1	19.9	109.0	3.8	41.7	45.5	197	56.9	60
	208/230-60-3	13.6	83.1	3.8	24.1	27.9	197	34.9	35
	460-60-3	6.1	41.0	2.4	12.0	14.4	416	18.0	20
	575-60-3	4.2	33.0	1.7	9.6	11.3	520	14.2	15
048	208/230-60-1	21.8	117.0	3.8	41.7	45.5	197	56.9	60
	208/230-60-3	13.7	83.1	3.8	24.1	27.9	197	34.9	35
	460-60-3	6.2	41.0	2.4	12.0	14.4	416	18.0	20
	575-60-3	4.8	33.0	1.7	9.6	11.3	520	14.2	15
060	208/230-60-1	26.3	134.0	3.8	41.7	45.5	197	56.9	60
	208/230-60-3	15.6	110.0	3.8	24.1	27.9	197	34.9	35
	460-60-3	7.8	52.0	2.4	12.0	14.4	416	18.0	20
	575-60-3	5.8	38.9	1.7	9.6	11.3	520	14.2	15
070	208/230-60-3	22.4	149.0	3.8	24.1	27.9	197	34.9	50
	460-60-3	10.6	75.0	2.4	12.0	14.4	416	18.0	25
	575-60-3	7.7	54.0	1.7	9.6	11.3	520	14.2	15

Note: Electric heat not available in unit sizes 009, 012 & 015.

Unit with PSC Motor – 5kW Electric Heat Coil

Table 16: 019 - 070

Unit Size	Voltage/Hz/ Phase	Compressor		PSC Fan Motor FLA	Electric Heater RLA	Total Unit FLA	Minimum Voltage	Minimum Circuit Amps	Maximum Fuse or HACR Breaker Size
		RLA	LRA						
019	208/230-60-1	9.0	48.0	1.0	22.5	23.5	197	29.4	30
	265/277-60-1	7.1	43.0	1.0	19.5	20.5	240	25.6	30
024	208/230-60-1	13.5	58.3	1.0	22.5	23.5	197	29.4	30
	265/277-60-1	9.0	54.0	1.0	19.5	20.5	240	25.6	30
030	208/230-60-1	14.1	73.0	3.0	22.5	25.5	197	31.9	35
	265/277-60-1	11.2	60.0	2.6	19.5	22.1	240	27.6	30
036	208/230-60-1	17.9	112.0	3.0	22.5	25.5	197	31.9	40

Note: Electric heat not available in unit sizes 009, 012 & 015.

Unit with EC Motor – 10kW Electric Heat Coil

Table 17: 019 - 070

Unit Size	Voltage/Hz/ Phase	Compressor		ECM Fan Motor FLA	Electric Heater RLA	Total Unit FLA	Minimum Voltage	Minimum Circuit Amps	Maximum Fuse or HACR Breaker Size
		RLA	LRA						
019	208/230-60-1	9.0	48.0	2.8	40.0	42.8	197	53.5	60
	265/277-60-1	7.1	43.0	2.4	34.7	37.1	240	46.4	50
024	208/230-60-1	13.5	58.3	2.8	40.0	42.8	197	53.5	60
	208/230-60-3	7.1	55.5	2.8	23.1	25.9	197	32.4	35
	265/277-60-1	9.0	54.0	2.4	34.7	37.1	240	46.4	50
030	208/230-60-1	14.1	73.0	4.3	40.0	44.3	197	55.4	60
	208/230-60-3	8.9	58.0	4.3	23.1	27.4	197	34.3	35
	265/277-60-1	11.2	60.0	4.1	34.7	38.8	240	48.5	50
036	208/230-60-1	17.9	112.0	4.3	40.0	44.3	197	55.4	60
	208/230-60-3	13.2	88.0	4.3	23.1	27.4	197	34.3	35
	460-60-3	6.0	44.0	4.1	11.6	15.7	416	19.6	20
042	208/230-60-1	19.9	109.0	6.8	41.7	48.5	197	60.6	70
	208/230-60-3	13.6	83.1	6.8	24.1	30.9	197	38.6	40
	460-60-3	6.1	41.0	5.5	12.0	17.5	416	21.9	25
048	208/230-60-1	21.8	117.0	6.8	41.7	48.5	197	60.6	70
	208/230-60-3	13.7	83.1	6.8	24.1	30.9	197	38.6	40
	460-60-3	6.2	41.0	5.5	12.0	17.5	416	21.9	25
060	208/230-60-1	26.3	134.0	9.1	41.7	50.8	197	63.5	70
	208/230-60-3	15.6	110.0	9.1	24.1	33.2	197	41.5	45
	460-60-3	7.8	52.0	6.9	12.0	18.9	416	23.6	25
070	208/230-60-3	22.4	149.0	9.1	24.1	33.2	197	41.5	50
	460-60-3	10.6	75.0	6.9	12.0	18.9	416	23.6	30

Note: Electric heat not available in unit sizes 009, 012 & 015.

EC motors on 460/60/3 volt units require a 265 volt power supply. Both a hot AND a neutral wire are required to obtain proper fan motor voltage. Therefore, 4-wires with a wye type wiring arrangement is required.

Unit with EC Motor – 5kW Electric Heat Coil

Table 18: 019- 070

Unit Size	Voltage/Hz/ Phase	Compressor		ECM Fan Motor FLA	Electric Heater RLA	Total Unit FLA	Minimum Voltage	Minimum Circuit Amps	Maximum Fuse or HACR Breaker Size
		RLA	LRA						
019	208/230-60-1	9.0	48.0	2.8	22.5	25.3	197	31.6	35
	265/277-60-1	7.1	43.0	2.4	19.5	21.9	240	27.4	30
024	208/230-60-1	13.5	58.3	2.8	22.5	25.3	197	31.6	35
	265/277-60-1	9.0	54.0	2.4	19.5	21.9	240	27.4	30
030	208/230-60-1	14.1	73.0	4.3	22.5	26.8	197	33.5	35
	265/277-60-1	11.2	60.0	4.1	19.5	23.6	240	29.5	30
036	208/230-60-1	17.9	112.0	4.3	22.5	26.8	197	33.5	40

Note: Electric heat not available in unit sizes 009, 012 & 015.

PSC Motor CFM - Sizes 009 - 070

Unit Size	Speed	Nominal	Factory Wired	External Static Pressure (inches of water column)													
				0.10	0.15	0.20	0.25	0.30	0.35	0.40	0.45	0.50	0.55	0.60	0.65	0.70	0.75
009	High	300	Yes	604	594	582	568	551	533	513	491	467	440	412	382	349	315
	Low		No	482	473	463	452	439	424	407	389	370	348	326	301	275	248
012	High	400	Yes	604	594	582	568	551	533	513	491	467	440	412	382	349	315
	Low		No	482	473	463	452	439	424	407	389	370	348	326	301	-	-
015	High	500	Yes	957	927	902	880	858	833	804	767	722	665	596	512	413	-
	Low		No	724	705	687	667	645	617	582	540	489	428	-	-	-	-
019	High	600	Yes	957	927	902	880	858	833	804	767	722	665	596	512	-	-
	Low		No	724	705	687	667	645	617	582	540	489	-	-	-	-	-
024	High	800	Yes	957	927	902	880	858	833	804	767	722	665	596	-	-	-
	Low		No	724	705	687	667	645	617	-	-	-	-	-	-	-	-
030	High	1000	Yes	1540	1532	1524	1514	1499	1478	1451	1417	1375	1327	1273	1216	1155	1095
	Low		No	1006	927	853	848	800	763	-	-	-	-	-	-	-	-
036	High	1300	Yes	1540	1532	1524	1514	1499	1478	1451	1417	1375	1327	1273	1216	1155	1095
	Low		No	1006	927	-	-	-	-	-	-	-	-	-	-	-	-
042	High	1400	Yes	2119	2086	2040	1988	1931	1872	1810	1743	1666	1574	1459	1310	1116	-
	Medium		No	-	-	-	-	-	-	1468	1436	1403	1290	1177	1080	-	-
	Low		No	-	-	-	-	-	-	-	-	-	-	-	-	-	-
048	High	1600	Yes	2119	2086	2040	1988	1931	1872	1810	1743	1666	1574	1459	1310	-	-
	Medium		No	-	-	-	-	-	-	1468	1436	1403	1290	-	-	-	-
	Low		No	-	-	-	-	-	-	-	-	-	-	-	-	-	-
060	High	2000	Yes	2303	2298	2302	2310	2313	2304	2280	2234	2165	2068	1942	1786	1601	-
	Medium		No	-	-	-	-	-	-	-	-	-	-	1554	-	-	-
	Low		No	-	-	-	-	-	-	-	-	-	-	-	-	-	-
070	High	2160	Yes	2303	2298	2302	2310	2313	2304	2280	2234	2165	2068	1942	1786	-	-
	Medium		No	-	-	-	-	-	-	-	-	-	-	-	-	-	-
	Low		No	-	-	-	-	-	-	-	-	-	-	-	-	-	-

EC Constant Torque Motor CFM Values - Sizes 009 - 012

Unit Size	Setting	Function	External Static Pressure (inches of water column)													
			.05	.10	.15	.20	.25	.30	.35	.40	.45	.50	.55	.60	.65	.70
009	Setting 4 (High)	Stage 1	458	445	434	420	405	385	374	362	350	339	331	316	301	282
	Setting 3 (Standard)		427	415	400	385	368	352	344	326	316	308	294	275	252	234
	Setting 2 (Medium)		391	375	360	342	324	310	299	290	274	257	239	229	199	185
	Setting 1 (Low)		391	375	360	342	324	310	299	290	274	257	239	229	199	185
	Setting 4 (High)	Stage 2	487	475	463	449	437	419	405	393	383	371	361	352	344	321
	Setting 3 (Standard)		458	445	434	420	405	385	374	362	350	339	331	316	301	282
	Setting 2 (Medium)		427	415	400	385	368	352	344	326	316	308	294	275	252	234
	Setting 1 (Low)		391	375	360	342	324	310	299	290	274	257	239	229	199	185
	A	Fan Only	458	445	434	420	405	385	374	362	350	339	331	316	301	282
	B		427	415	400	385	368	352	344	326	316	308	294	275	252	234
	C		391	375	360	342	324	310	299	290	274	257	239	229	199	185
	D		340	323	302	285	270	259	241	219	198	177	161	147	131	123
012	Setting 4 (High)	Stage 1	458	445	434	420	405	385	374	362	350	339	331	316	301	282
	Setting 3 (Standard)		427	415	400	385	368	352	344	326	316	308	294	275	252	234
	Setting 2 (Medium)		391	375	360	342	324	310	299	290	274	257	239	229	199	-
	Setting 1 (Low)		391	375	360	342	324	310	299	290	274	257	239	229	199	-
	Setting 4 (High)	Stage 2	487	475	463	449	437	419	405	393	383	371	361	352	344	321
	Setting 3 (Standard)		458	445	434	420	405	385	374	362	350	339	331	316	301	282
	Setting 2 (Medium)		427	415	400	385	368	352	344	326	316	308	294	275	252	234
	Setting 1 (Low)		391	375	360	342	324	310	299	290	274	257	239	229	199	185
	A	Fan Only	458	445	434	420	405	385	374	362	350	339	331	316	301	282
	B		427	415	400	385	368	352	344	326	316	308	294	275	252	234
	C		391	375	360	342	324	310	299	290	274	257	239	229	199	185
	D		340	323	302	285	270	259	241	219	198	177	161	147	131	123

Constant CFM motor CFM values - Sizes 015 - 070

Table 19: Single stage units with constant CFM type EC motor

Unit Size	MicroTech III Unit Controller								I/O Expansion Module	
	Setting	Maximum ESP (in. wg.) ²	¹ Low CFM Heat	¹ High CFM Heat	¹ Low CFM Cool	¹ High CFM Cool	Dehumidification	Electric Heat	Setting	Fan Only
015	4 (High)	0.7	450	500	450	500	430	500	A	450
	3 (Standard)		410	450	410	450	390	500	B	410
	2 (Medium)		370	410	370	410	370	500	C	370
	1 (Low)		370	370	370	370	370	500	D	300
019	4 (High)	0.7	570	620	570	620	540	620	A	570
	3 (Standard)		520	570	520	570	490	620	B	520
	2 (Medium)		460	520	460	520	460	620	C	460
	1 (Low)		460	460	460	460	460	620	D	390
024	4 (High)	0.7	750	800	750	800	730	800	A	750
	3 (Standard)		710	750	710	750	690	800	B	710
	2 (Medium)		670	710	670	710	670	800	C	670
	1 (Low)		670	670	670	670	670	800	D	600
030	4 (High)	0.7	900	1000	900	1000	844	1000	A	900
	3 (Standard)		790	900	790	900	740	1000	B	790
	2 (Medium)		690	790	690	790	690	1000	C	690
	1 (Low)		690	690	690	690	690	1000	D	530
036	4 (High)	0.7	1180	1300	1180	1300	1120	1300	A	1180
	3 (Standard)		1060	1180	1060	1180	100	1300	B	1060
	2 (Medium)		940	1060	940	1060	940	1300	C	940
	1 (Low)		940	940	940	940	940	1300	D	760
042	4 (High)	0.7	1220	1400	1220	1400	1130	1400	A	1220
	3 (Standard)		1040	1220	1040	1220	950	1400	B	1040
	2 (Medium)		860	1040	860	1040	860	1400	C	860
	1 (Low)		860	860	860	860	860	1400	D	590
048	4 (High)	0.7	1490	1660	1490	1660	1400	1660	A	1490
	3 (Standard)		1320	1490	1320	1490	1240	1660	B	1320
	2 (Medium)		1160	1320	1160	1320	1160	1660	C	1160
	1 (Low)		1160	1160	1160	1160	1160	1660	D	900
060	4 (High)	0.7	1860	2000	1860	2000	1800	2000	A	1860
	3 (Standard)		1730	1860	1730	1860	1660	2000	B	1730
	2 (Medium)		1590	1730	1590	1730	1590	2000	C	1590
	1 (Low)		1590	1590	1590	1590	1590	2000	D	1390
070	4 (High)	0.7	2010	2160	2010	2160	1940	2160	A	2010
	3 (Standard)		1860	2010	1860	2010	1790	2160	B	1860
	2 (Medium)		1720	1860	1720	1860	1720	2160	C	1720
	1 (Low)		1720	1720	1720	1720	1720	2160	D	1500

Notes: ¹ The unit is capable of high-low fan performance through the use of a 2-stage thermostat wired to specific terminals for High-Low CFM fan performance. Standard operation with a 1-stage thermostat is indicated as High CFM fan performance.

Table 20: Physical data

Unit Size		009	012	015	019	024	030	036
Fan Wheel - D x W (In.)		6¼ x 8	6¼ x 8	7 x 7½	7 x 7½	7 x 7½	7 x 7½	7 x 7½
Fan Motor Horsepower	PSC	1/8	1/8	1/6	1/6	1/6	1/3	1/2
	ECM	1/10	1/10	1/3	1/3	1/3	1/2	1/2
Coil Face Area (Sq. Ft.)		2.22	2.22	3.00	3.00	3.00	3.50	3.50
Coil Rows		3	3	3	3	3	3	3
Refrigerant Charge (Oz.)	Standard Unit	28.5	29	43	46	44	51.5	54.5
	Hot Gas Reheat	n/a	n/a	n/a	50	52	60	63
Filter, (Qty.) Size (In.)		(2) 20W x 10H x 1		(1) 20W x 24W x 1			(2) 20W x 14H x 1	
		(2) 20W x 10H x 2		(1) 20W x 24W x 2			(2) 20W x 14H x 2	
		(2) 20W x 10H x 4 Merv 13		(1) 20W x 24W x 4 Merv 13			(2) 20W x 14H x 4 Merv 13	
Water Connections, Female NPT (In.)		1/2	1/2	1/2	1/2	1/2	3/4	3/4
Condensate Connections, Female NPT (In.)		3/4	3/4	3/4	3/4	3/4	3/4	3/4
Water Volume (U.S. Gallons)		0.24	0.24	0.49	0.49	0.49	0.73	0.73
¹ Weight, Operating (Lbs.) / Hot Gas Reheat		n/a	n/a	n/a	221 / 253	224 / 255	244 / 280	247 / 283
¹ Weight, Shipping (Lbs.) / Hot Gas Reheat		n/a	n/a	n/a	243 / 275	245 / 277	266 / 302	269 / 305
Shipping Dimensions		27L x 27W x 38H		30L x 30W x 49H	30L x 30W x 53H	30L x 30W x 54H	30L x 30W x 58H	

Unit Size		042	048	060	070
Fan Wheel - D x W (In.)		11 x 10%	11 x 10%	11 x 10%	11 x 10%
Fan Motor Horsepower	PSC	1/2	3/4	3/4	3/4
	ECM	3/4	3/4	1.0	1.0
Coil Face Area (Sq. Ft.)		6.30	6.30	6.63	6.63
Coil Rows		3	3	3	3
Refrigerant Charge (Oz.)	Standard Unit	68	66	86.6	102
	Hot Gas Reheat	77.5	72.5	102.5	108.5
Filter, (Qty.) Size (In.)		(1) 30W x 24H x 1		(2) 30W x 18H x 1	
		(1) 30W x 24H x 2		(2) 30W x 18H x 2	
		(1) 30W x 24H x 4 Merv 13		(2) 30W x 18H x 4 Merv 13	
Water Connections, Female NPT (In.)		3/4	3/4	3/4	3/4
Condensate Connections, Female NPT (In.)		3/4	3/4	3/4	3/4
Water Volume (U.S. Gallons)		0.95	0.95	1.15	1.15
¹ Weight, Operating (Lbs.) / Hot Gas Reheat		318 / 356	321 / 361	387 / 430	389 / 432
¹ Weight, Shipping (Lbs.) / Hot Gas Reheat		340 / 378	345 / 383	412 / 452	414 / 454
Shipping Dimensions		38L x 31W x 53H			38L x 31W x 65H

Notes: ¹ Add 8 lbs. to weights shown for units configured with electric heat.

n/a = Hot Gas Reheat option not available for unit sizes 009, 012 & 015.

Sizes 009 & 012 – Left Hand and Right Hand Return

Notes: Left and right hand return determined by facing the water connection side of the unit.

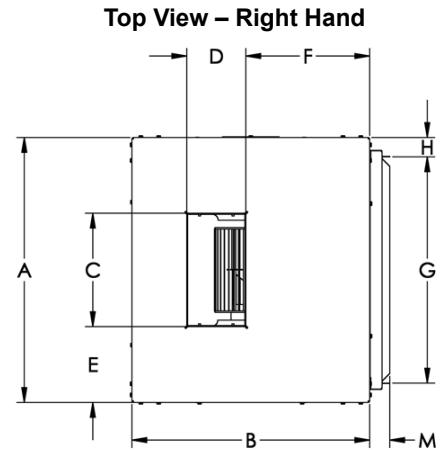
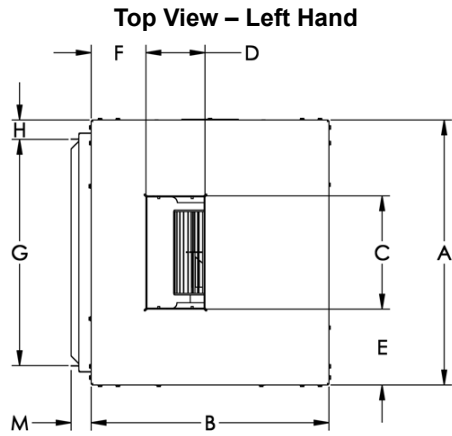

Overall Unit Dimensions = 22 1/4" D x 20" W x 37" H

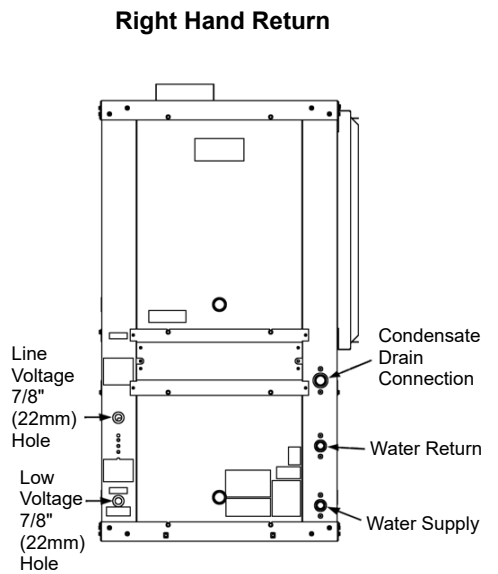
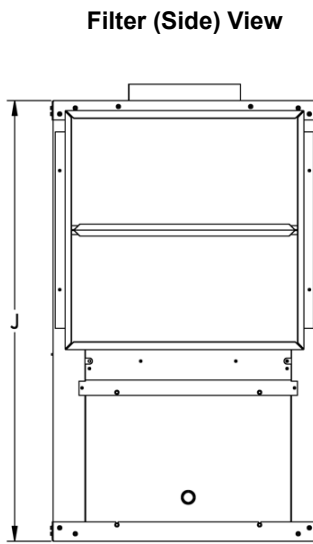
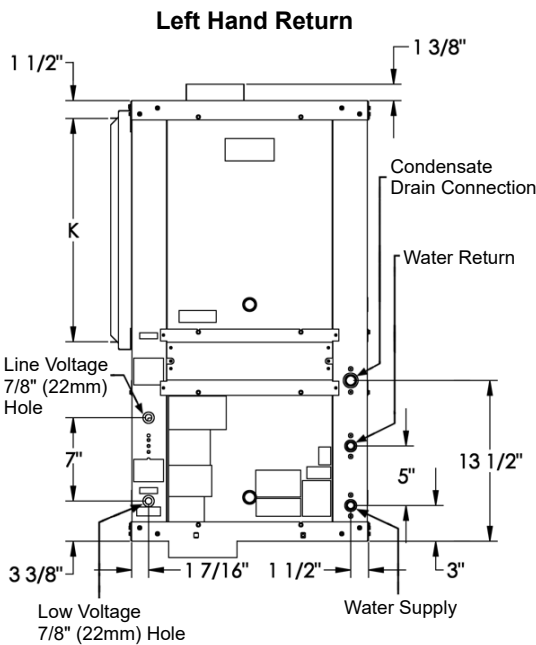

Dimensions

Unit Size	A	B	C	D	E	F (Lft Hand)	F (Rht Hand)	G	H	J	K	M
009-012	22 1/4" (565mm)	20" (508mm)	9 1/2" (241mm)	5" (127mm)	6 3/8" (162mm)	4 5/8" (118mm)	10 7/16" (265mm)	19" (483mm)	1 5/8" (41mm)	37" (940mm)	18 3/4" (476mm)	1 1/16" (43mm) 2 1/16" (68mm)

Note: Dimensions are approximate. "M" dimension includes duct flange.

Standard 1" Filter Dimensions

Unit Size	O	P	N	Quantity
009 – 012	1" (25mm)	20" (508mm)	10" (254mm)	2

Optional Filters Dimensions

Unit Size	O	P	N	Quantity
009 – 012	2" (51mm)	20" (508mm)	10" (254mm)	2
	4" (102mm)			

Note: Nominal filter thickness is 3/4" (± 1/16") or 1-3/4" (±1/16")

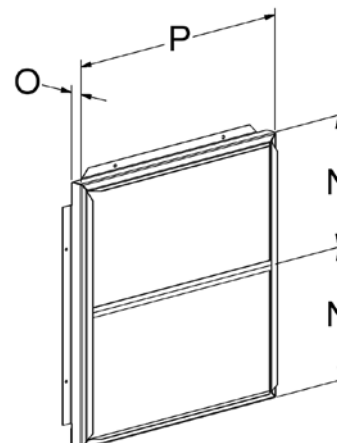

Sizes 015, 019, 024 – Left Hand and Right Hand Return

Note: Left and right hand return determined by facing the water connection side of the unit.

Top View – Left Hand

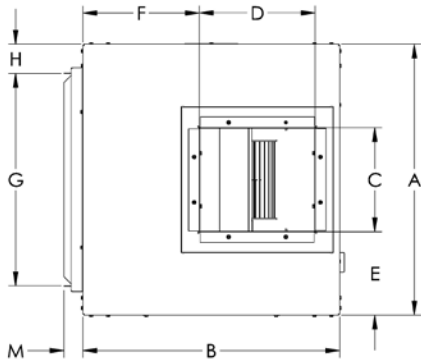

Top View – Right Hand

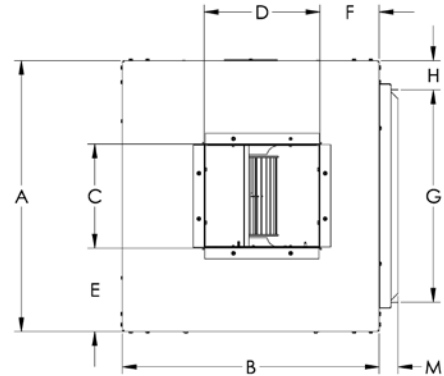

Overall Unit Dimensions =
24¼"D x 23"W x 46½"H

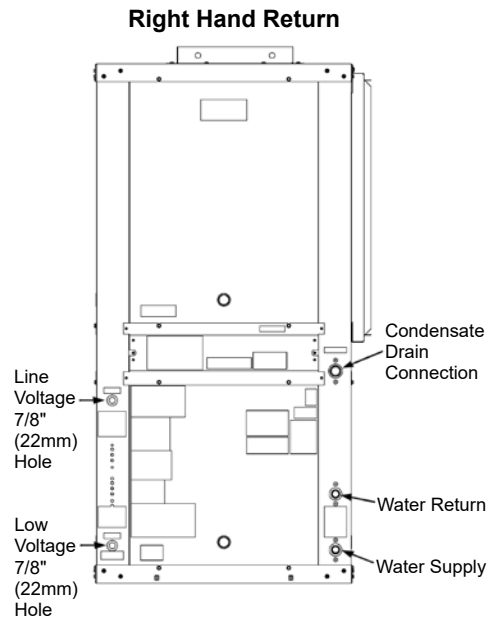
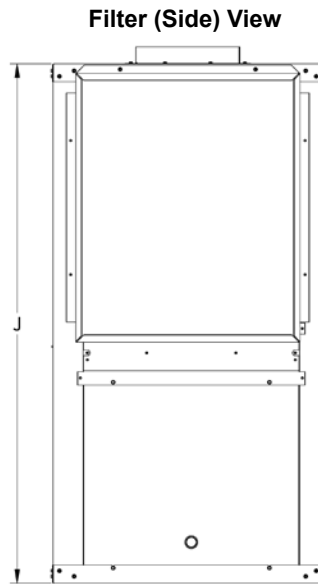
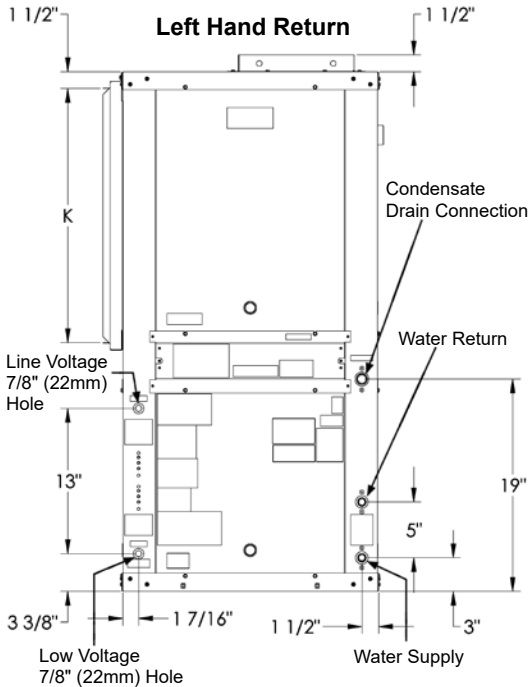

Dimensions

Unit Size	A	B	C	D	E	F (Lft Hand)	F (Rht Hand)	G	H	J	K	M
015– 024	24¼" (616mm)	23" (584mm)	9⅝" (238mm)	10⅜" (264mm)	7⅞" (189mm)	10⅞" (265mm)	5⅝" (135mm)	19" (483mm)	2⅝" (67mm)	46½" (1181mm)	22¾" (578mm)	1⅞" (43mm)
												2⅞" (68mm)

Note: Dimensions are approximate. "M" dimension includes duct flange.

Standard 1" Filter Dimensions

Unit Size	O	P	N	Quantity
015– 024	1" (25mm)	20" (508mm)	24" (254mm)	1

Optional Filters Dimensions

Unit Size	O	P	N	Quantity
015– 024	2" (51mm)	20" (508mm)	24" (254mm)	1
	4" (102mm)			

Note: Nominal filter thickness is 3/4" (± 1/16") or 1-3/4" (± 1/16")

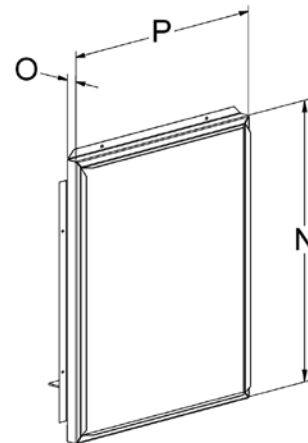

Sizes 030, 036 – Left Hand and Right Hand Return

Note: Left and right hand return determined by facing the water connection side of the unit.

Top View – Left Hand

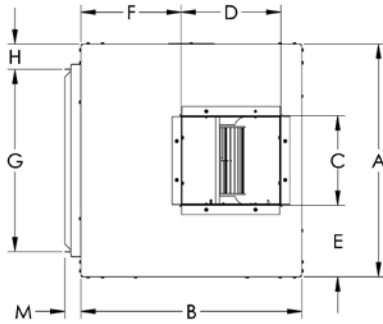

Top View – Right Hand

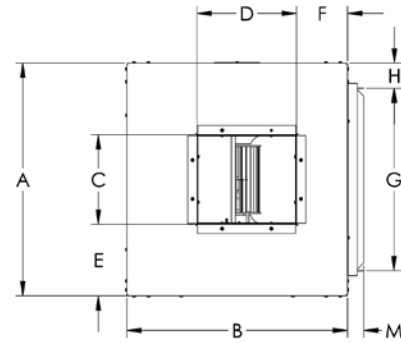

Overall Unit Dimensions =
24 1/4"D x 23"W x 50 1/2"H

Left Hand Return

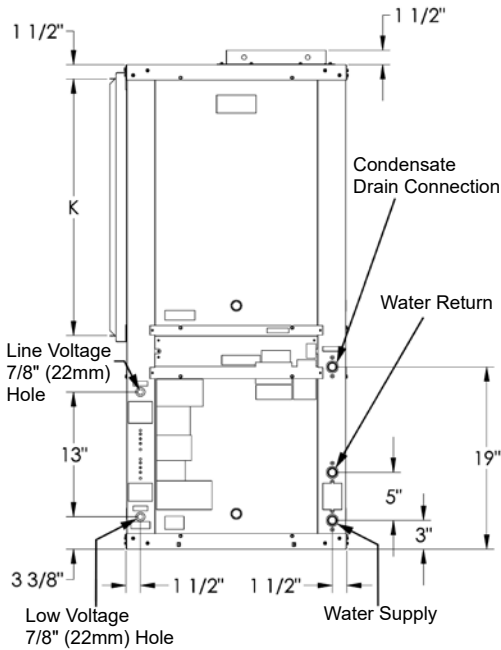

Filter (Side) View

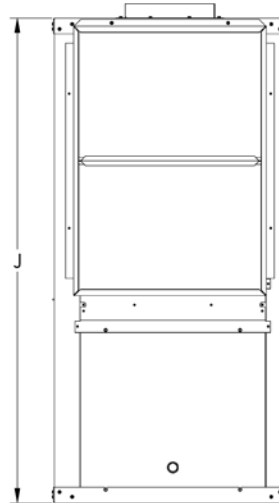

Right Hand Return

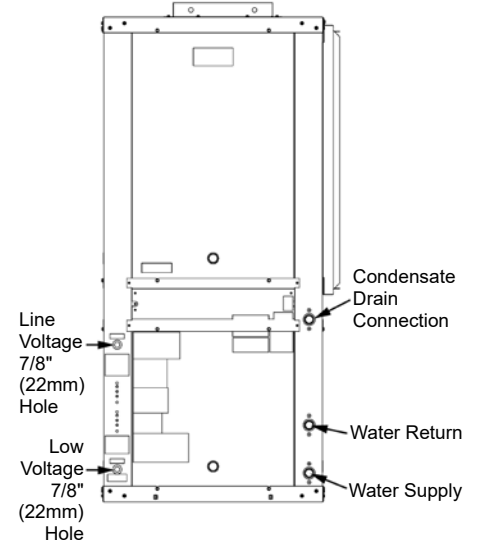

Dimensions

Unit Size	A	B	C	D	E	F (Lft Hand)	F (Rht Hand)	G	H	J	K	M
030-036	24 1/4" (616mm)	23" (584mm)	9 3/8" (238mm)	10 3/8" (264mm)	7 1/16" (189mm)	10 7/16" (265mm)	5 5/16" (135mm)	19" (483mm)	2 5/8" (67mm)	50 1/2" (1283mm)	26 3/4" (680mm)	1 1/16" (43mm) 2 1/16" (68mm)

Note: Dimensions are approximate. "M" dimension includes duct flange.

Standard 1" Filter Dimensions

Unit Size	O	P	N	Quantity
030-036	1" (25mm)	20" (508mm)	14" (356mm)	2

Optional Filter Dimensions

Unit Size	O	P	N	Quantity
030-036	2" (51mm)	20" (508mm)	14" (356mm)	2
	4" (102mm)			

Note: Nominal filter thickness is 3/4" (± 1/16") or 1-3/4" (± 1/16")

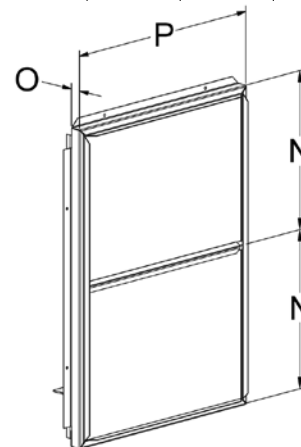

Sizes 042, 048 – Left Hand and Right Hand Return

Note: Left and right hand return determined by facing the water connection side of the unit.

Top View – Left Hand

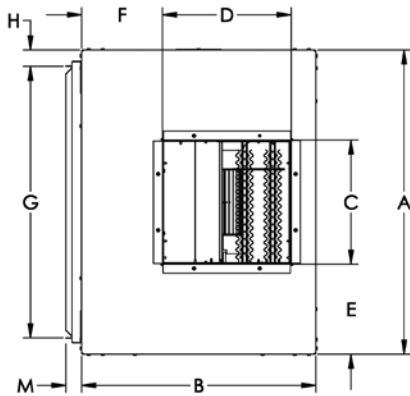

Top View – Right Hand

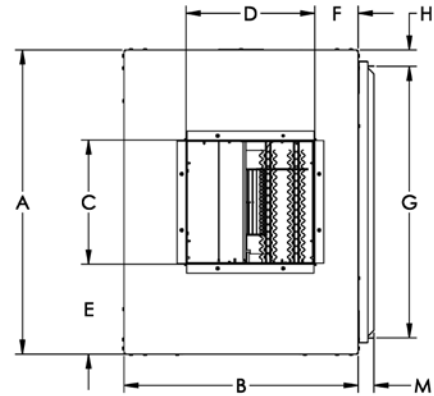

Overall Unit Dimensions =
32½"D x 25"W x 46½"H

Left Hand Return

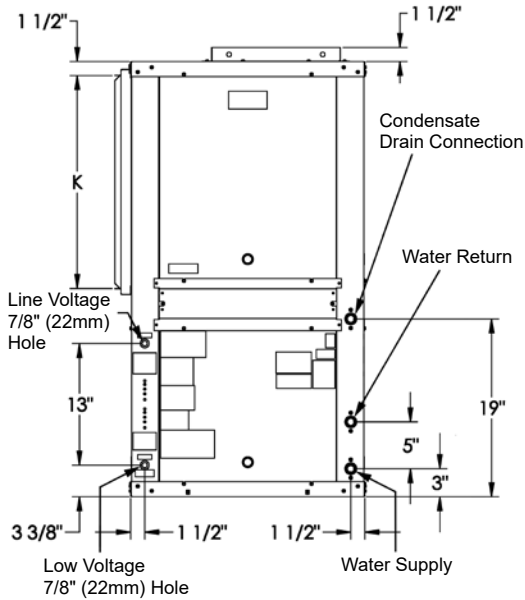

Filter (Side) View

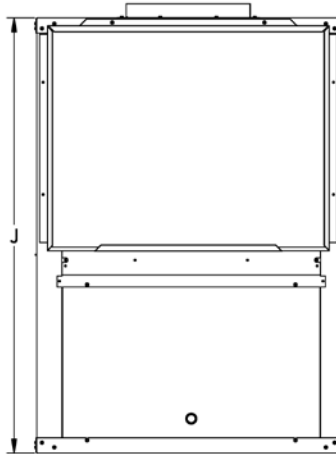

Right Hand Return

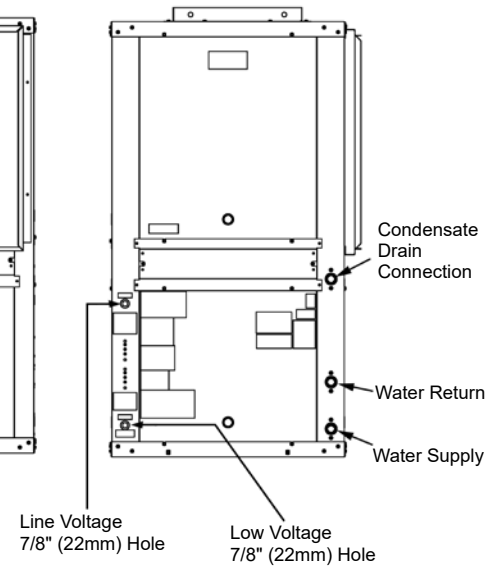

Dimensions

Unit Size	A	B	C	D	E	F (Lft Hand)	F (Rht Hand)	G	H	J	K	M
042-048	32½" (826mm)	25" (635mm)	13¼" (337mm)	13¼" (349mm)	9⅝" (245mm)	9⅝" (245mm)	5⅝" (143mm)	29" (737mm)	1¾" (45mm)	46½" (1181mm)	22¾" (578mm)	1⅞" (43mm) 2⅞" (68mm)

Note: Dimensions are approximate. "M" dimension includes duct flange.

Standard 1" Filter Dimensions

Unit Size	O	P	N	Quantity
042-048	1" (25mm)	30" (762mm)	24" (610mm)	1

Optional Filters Dimensions

Unit Size	O	P	N	Quantity
042-048	2" (51mm)	30" (762mm)	24" (610mm)	1
	4" (102mm)			

Note: Nominal filter thickness is 3/4" (± 1/16") or 1-3/4" (± 1/16")

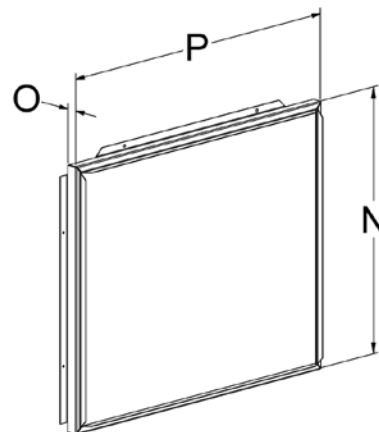

Sizes 060, 070 – Left Hand and Right Hand Return

Note: Left and right hand return determined by facing the water connection side of the unit.

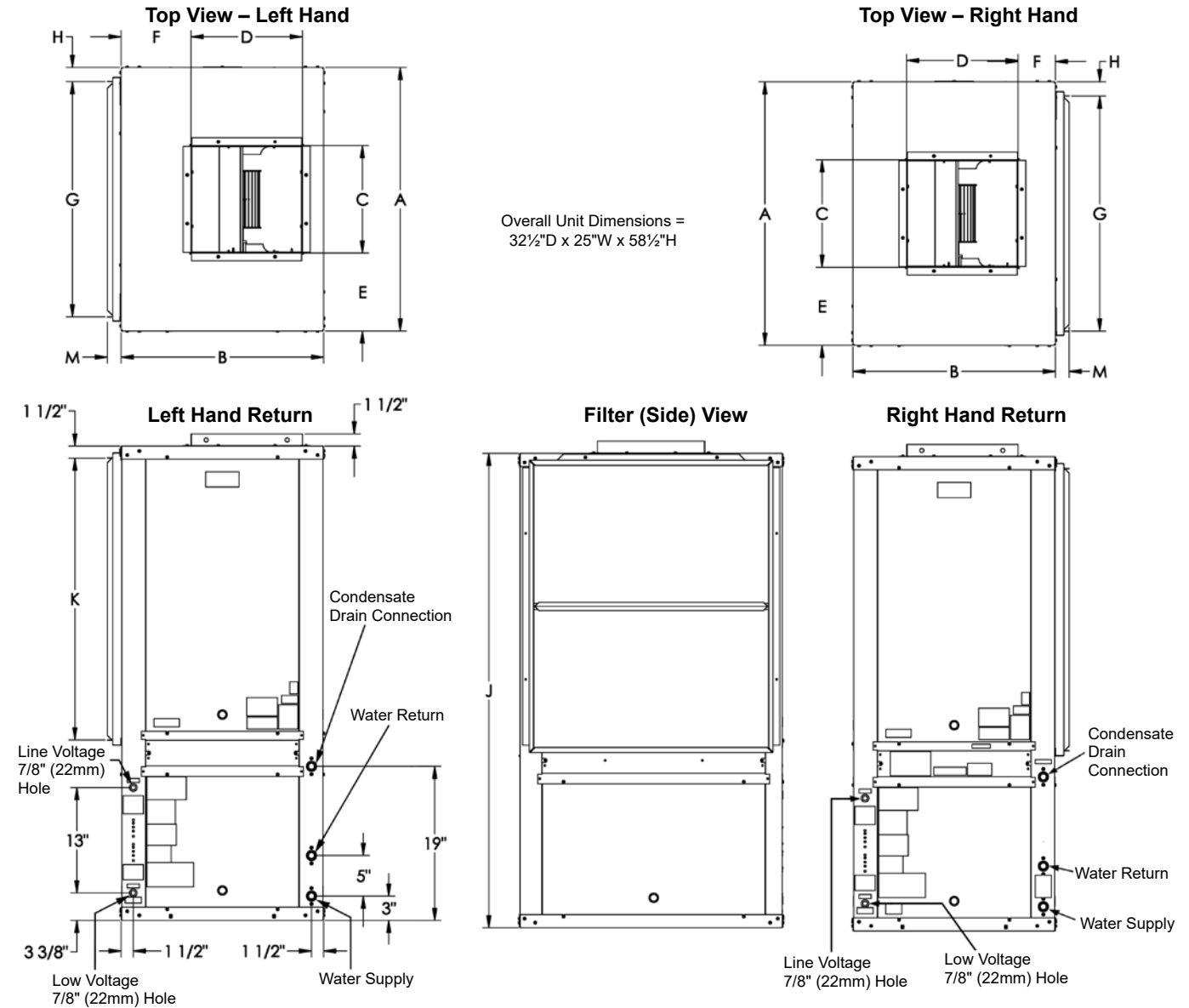

Dimensions

Unit Size	A	B	C	D	E	F (Lft Hand)	F (Rht Hand)	G	H	J	K	M
060– 070	32½" (826mm)	25" (635mm)	13¼" (337mm)	13¼" (349mm)	9⁄₈" (245mm)	9⁄₈" (245mm)	5⁄₈" (143mm)	29" (737mm)	1¾" (45mm)	58½" (1486mm)	34¾" (883mm)	1¹¹⁄₁₆" (43mm) 2¹¹⁄₁₆" (68mm)

Note: Dimensions are approximate. "M" dimension includes duct flange.

Standard 1" Filter Dimensions

Unit Size	O	P	N	Quantity
060– 070	1" (25mm)	30" (762mm)	18" (457mm)	2

Optional Filters Dimensions

Unit Size	O	P	N	Quantity
060– 070	2" (51mm)	30" (762mm)	18" (457mm)	2
	4" (102mm)			

Note: Nominal filter thickness is 3/4" (± 1/16") or 1-3/4" (± 1/16")

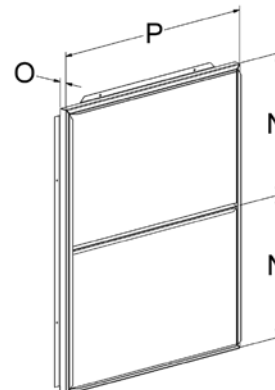





Table 21: Thermostats & remote room sensors for standalone operation





Thermostats & Remote Sensors Used with MicroTech III – Standalone Operation		Thermostats						Remote Room Sensor		
		Programmable / Non-Programmable				Non-Programmable	Programmable	Part #:	Part #:	Part #:
Standard										
Wi-Fi										
Feature										
Display	Room Temp. & Setpoint	•	•	•	•	•	•			
	Room Humidity & Setpoint					•				
Changeover	Manual	•	•	•	•	•	•			
	Automatic	•	•	•	•	•	•			
Stages	Heating	2	2	3	2	2	2			
	Cooling	2	3	2	2	2	2			
Operating Modes	System	Cool-Off-Heat-Auto	Cool-Off-Heat-Auto	Cool-Off-Heat-Auto	Cool-Off-Heat-Auto	Cool-Off-Heat-Auto	Cool-Off-Heat-Auto			
	Fan	On-Auto-Hourly	On-Auto-Hourly	On-Auto-Hourly	On-Auto-Hourly	On-Auto	On-Auto			
Annunciation	Status LED 5VDC					•	•			
	Alarm Fault LED 24 VAC	•	•	•	•	•	•			
Reset	Alarm	•	•	•	•	•	•			
	Override	•	•	•	•	•	•			
Remote Sensors	Indoor	•	•	•	•	•	•			
	Application									
Dehumidification	Smart Dehumid.				•					
	Simplified		•							
	Humidistat Controlled				•					
Electric Heat	Dehumid. Only				•					
	Boilerless	•	•	•	•	•	•			
	Supplemental	•	•	•	•	•	•			
Waterside Economizer	Primary	•	•	•	•	•	•			
	Emergency	•	•	•	•	•	•			
Hydronic Heat	–	•	•	•	•	•	•			
	–	•	•	•	•	•	•			
910193126 910193127 910193128 910193129 910193131 910193132 910193133 910193134										
910121746 & 910121748										

Table 22: Room temperature sensors for BAS operation

Sensors Used with MicroTech III Control – Building Automated System (BAS) Operation		Room Temperature Sensors			
		Digitally Adjustable	Digitally Adjustable Display Sensor	Basic Room Sensor With Cool to Warm Adjust	Basic Room Sensor
					
		With Temperature & Humidity Display for Smart Dehumidification or Waterside Economizer Operation	With Temperature Display, Indicates, ALARM, Override and Occupancy.	Senses Temperature, With Temperature Adjust Cool to Warm, LED Status Indication, Override Reset Button	Senses Temperature, LED Status Indication, Override Reset Button
	Part # 910121754	Part # 910152147	Part # 910171464	Part # 910152149	
Feature					
Setpoint Adjustment		Digitally Adjustable	Digitally Adjustable	Cool to Warm	None
Display	Room Temperature & Setpoint	●	●		
	Room Humidity & Setpoint	●			
Stages	Heating	4	4	4	4
	Cooling	3	3	3	3
Operating Modes	System	Heat-Cool-Auto-Off-Dehum			
	Fan	Auto-On			
	Occupancy	LCD Display of Occupied-Unoccupied Icon	LCD Display of Occupied-Unoccupied Icon		
Annunciation	Status LED	LCD Display of Unit Status	LCD Display of Unit Status	●	●
	LCD Alarm Display	●	●		
Reset	Alarm	●	●	●	●
	Setback Override	●	●	●	●
Application					
Dehumidification		●			
Electric Heat	Boilerless	●	●	●	●
	Supplemental	●	●	●	●
	Primary	●	●	●	●
Waterside Economizer	-	●	●	●	●
Hydronic Heat	-	●	●	●	●

Notes: For complete specification and wiring information refer to ED 19107_WSHP-Tstats_Specs.

Table 23: Room temperature sensors for BAS operation

Sensors Used with MicroTech III Control – Building Automated System (BAS) Operation		Room Temperature Sensors			
		Adjustable Cool/Warm with Occupancy Switch	Adjustable 55°F to 95°F	Adjustable +/- 3°F (+/- 1.5°C)	Basic Sensor
					
		Part # 910121753	Part # 669529101	Part # 669529201	Part # 669529001
Feature					
Setpoint Adjustment		Cool to Warm	55°F to 95°F (13° to 35°C)	-3° to +3°F (-1.5° to +1.5°C)	None
Display	Room Temperature & Setpoint				
	Room Humidity & Setpoint				
Stages	Heating	4	4	4	4
	Cooling	3	3	3	3
Operating Modes	System	Cool-Auto-Heat	Cool-Auto-Heat	Cool-Auto-Heat	
	Fan	Auto-On	Auto-On	Auto-On	
	Occupancy	Occ-Unoc-Off			
Annunciation	Status LED	●	●	●	●
	LCD Alarm Display				
Reset	Alarm	●	●	●	●
	Setback Override	●	●	●	●
Application					
Dehumidification					
Waterside Economizer	–	●	●	●	●
Electric Heat	Boilerless	●	●	●	●
	Supplemental	●	●	●	●
	Primary	●	●	●	●
Hydronic Heat	–	●	●	●	●

Thermostats For Use with MicroTech III Standalone – Wiring

Programmable Electronic Thermostat 2 Heat/2 Cool, 7-Day Programmable, Auto Changeover, Hardwired – P/N 910193126 & Wi-Fi P/N 910193131

MicroTech III Controller Terminals TB2

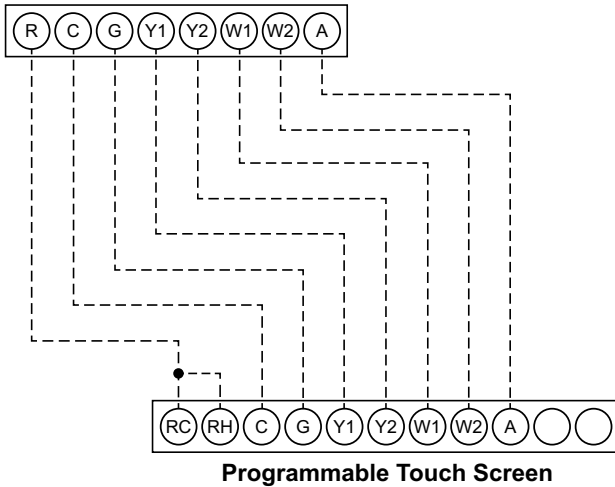

Notes: Includes thermostat and wall plate Refer to IO manual 910193126

Programmable Electronic Thermostat 2 Heat/3 Cool, 7-Day Programmable, Auto Changeover, Hardwired – P/N 910193127 & Wi-Fi P/N 910193132

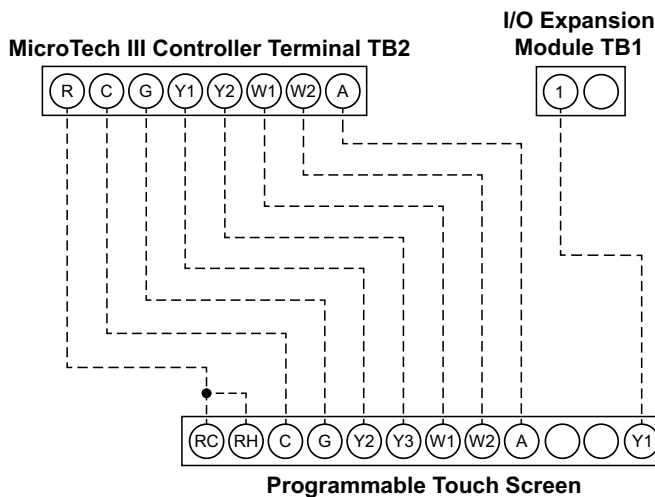

Notes: Includes thermostat and wall plate Refer to IO manual 910193127

Programmable Electronic Thermostat 3 Heat/2 Cool, 7-Day Programmable, Auto Changeover, Hardwired – P/N 910193128 & Wi-Fi P/N 910193133

MicroTech III Controller Terminals TB2

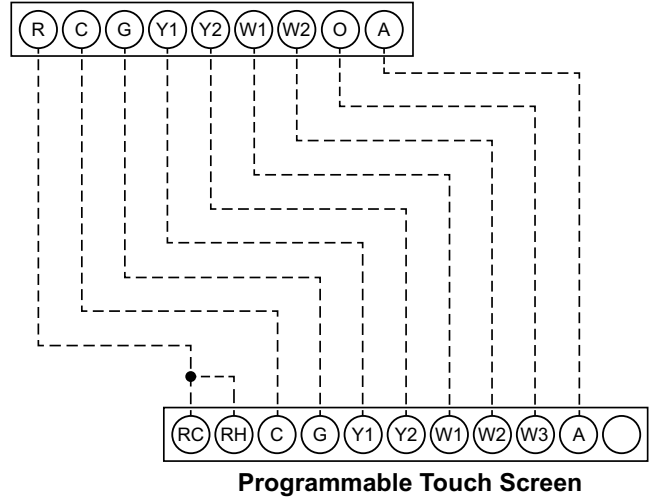

Notes: Includes thermostat and wall plate Refer to IO manual 910193128

Programmable Electronic Thermostat 2 Heat/2 Cool, 7-Day Programmable, Dehumidification, Auto Changeover, Hardwired – P/N 910193129 & Wi-Fi P/N 910193134

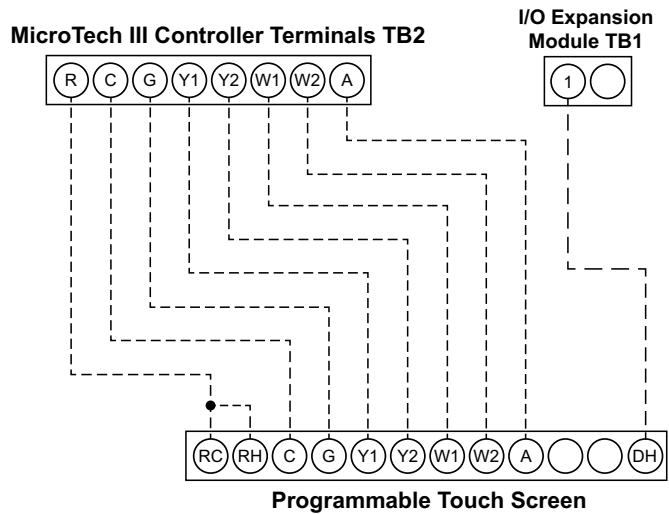

Notes: Includes thermostat and wall plate Refer to IO manual 910193129

Programmable & Non-Programmable Electronic Thermostats 2 Heat/2 Cool, Auto Changeover, Hardwired – P/N 910121746 & P/N 910121748

WSHP MicroTech III Controller
Terminals TB1 and TB2

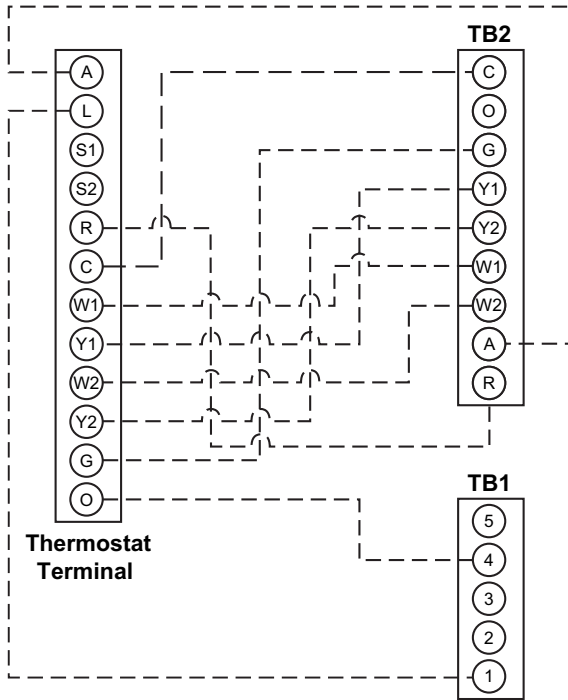

Notes: Includes thermostat and wall plate. Refer to 910121746 or 910121748 Install Manual.

Sensors Used with MicroTech III Control – Building Automated System Operation – Wiring Adjustable Cool/Warm with Occupancy Switch – P/N 910121753

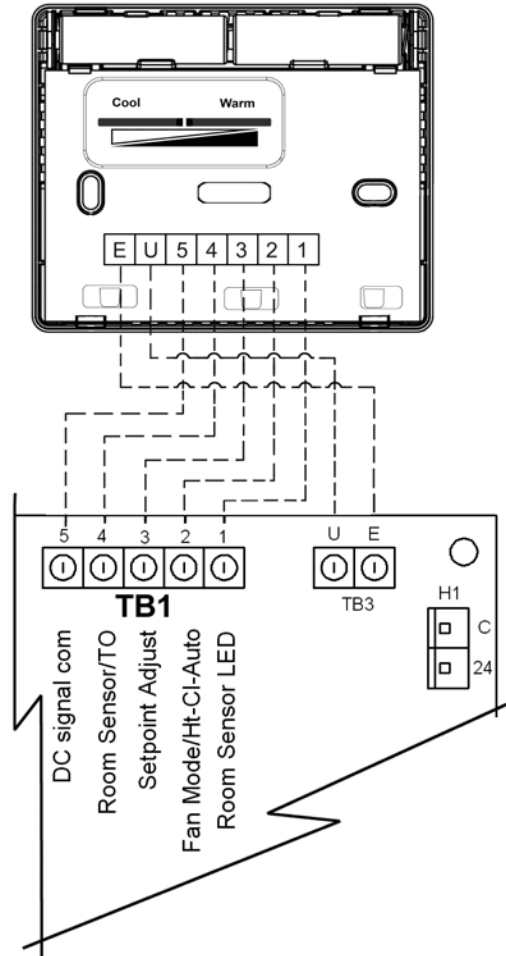

Adjustable 55°F to 95°F – P/N 669529101 & Adjustable +/- 3°F (+/- 1.5°C) – P/N 669529201

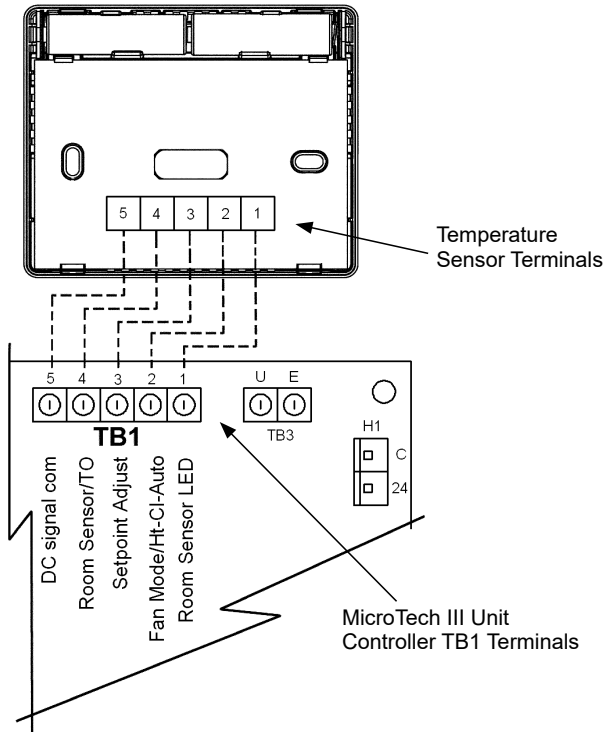

Temperature Sensor Wiring to MicroTech III Unit Controller – P/N 669529001

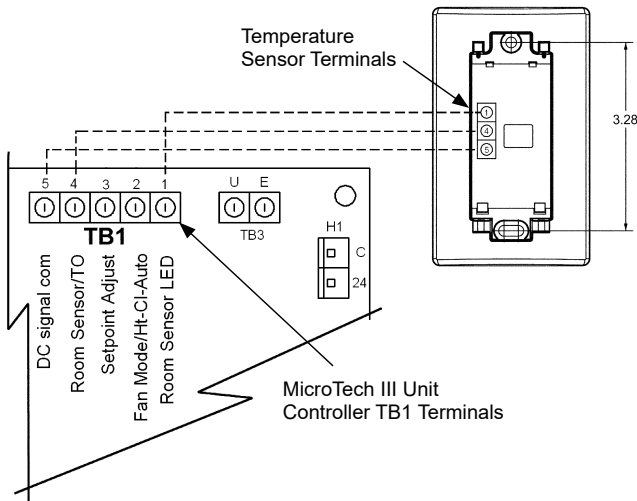

Accessory Remote Room Sensors – Wiring (Part No.667720401 & 107096001)

Used with Thermostats 910193126, 910193127, 910193128, 910193129, 910193131 910193132, 910193133, 910193134

The remote indoor temperature sensor provides the ability to measure room temperature remote from the thermostat location.

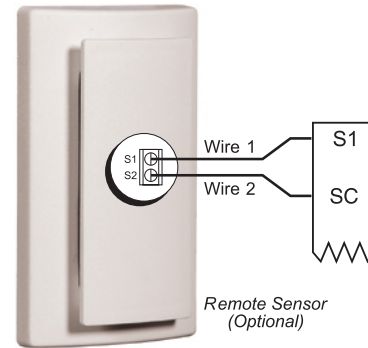

Accessory Remote Room Sensor (Part No. 107096010)

Used with Thermostats – P/N 910121746 and P/N 910121748

The remote indoor temperature sensor provides the ability to measure room temperature remote from the thermostat location.

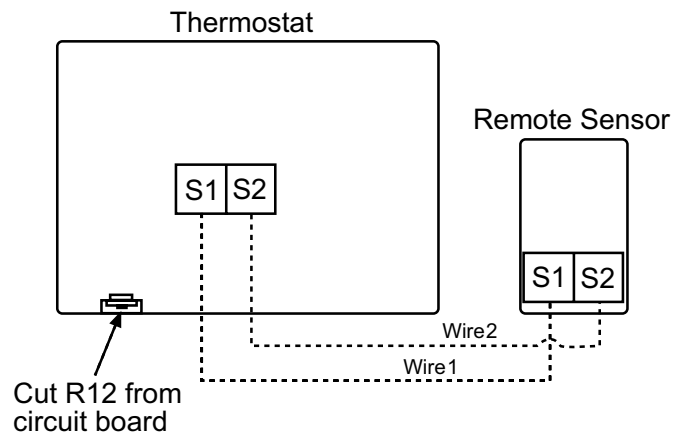

Supply and Return Water Hoses

Available as fire rated construction in 2 or 3 foot (610 mm or 914 mm) lengths. Fire rated hoses have a synthetic polymer core with an outer rated covering of stainless steel. Fittings are steel. Assembly is "fire rated" and tested according to UL 94 with a VO rating and ASTM 84. Each hose has MPT connections. Fire rated hoses have a swivel connection at one end. Hoses are available in 3/4" (19 mm) to match the FPT fittings on the unit.

Figure 24: Flow control, supply and return water hoses



Condensate Hose Kit

Available as a long clear plastic hose with the necessary clamps and a MPT hose fitting for connection to the FPT field piping.

Figure 25: Condensate hose kit



Combination Balancing and Shutoff (Ball) Valves

Constructed of brass and rated at 400 psig (2758 kPa) maximum working pressure. Valves have a built-in adjustable memory stop to eliminate rebalancing. Valves have FPT connections on both ends for connection to the water hose and to the field piping.

Figure 26: Shut off ball valve



Field Installed Controls

Used for variable pumping applications, the valve is wired in the compressor circuit and piped in the return water line from the unit.

Figure 27: 2-way motorized valve



- A motorized valve relay and control valve assembly includes a relay, valve and wire harness. The valve opens when the compressor is on and closes when the compressor is off. The valve is rated for 300 psig (2070 kPa).
- A multiple unit control panel allows a single thermostat to control up to three units in parallel.
- An auxiliary relay controls optional devices when the fan is operating. The relay has SPDT contacts.

Two-Inch or Four-Inch Filter Rack

Selectable as factory-mounted or as an optional field-installed kit, replacing the standard 1" filter rack. It provides a 1" (25 mm) extended collar for connection of return air ductwork and accepts a 2" (51 mm) thick, throwaway filter in a 4-sided filter rack with duct collar. Where high indoor air quality is required units will have a 4" thick, high efficiency Merv 13 filter in a 4-sided filter rack with duct collar. The filter rack can be mounted for left hand or right hand filter removal by rotating it 180 degrees. Two thumb screws allow easy removal of the access door for quick filter changes without using a tool.

Figure 28: Optional two-inch or four-inch filter rack

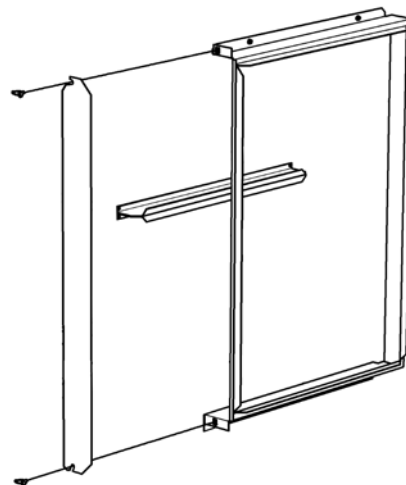

MicroTech III Unit Controller (Standalone)

Figure 29: 208-230-460-575/60Hz/3-Phase

Drawing No. 668991201

Wiring diagrams are typical. For the latest drawing version refer to the wiring diagram located on the inside of the controls access panel of the unit.

Legend

Item	Description
C1	Capacitor-Compressor
C2	Capacitor-Fan
CC	Compressor - Contactor
CM	Compressor - Motor
COS	Condensate Overflow Sensor
DAT	Discharge Air Temp Sensor
EWT	Entering Water Temp. Sensor
HP	High Pressure Switch
HTR	Electric Heater Cartridge
IOEXP	I/O Expansion Board / Harness
ISO-NC	Isolation Valve - Normally Closed
ISO-NO	Isolation Valve - Normally Open
DSHP	Desuperheater
DISC	Non-Fused Disconnect Switch
LED1	LED Annunciator / Harness
LP	Low Pressure Switch
SLTS	Suction Line Temp Sensor
LWT	Leaving Water Temp Sensor
MIII	MicroTech III Main Board
R1	Relay - Fan Motor
RAT	Return Air Temp Sensor
RV	Reversing Valve Solenoid
X1	Primary 24VAC Transformer
—	Standard Unit Wiring
- - -	Factory Installed Options

208V	RED
230V	ORG

Notes:

- Main Board Jumpers
 - JP3 Geothermal
- IO Expansion Board Jumpers
All open for single stage compressor
 - JP2 HGRH
 - JP3 Supplemental EH
 - JP4 Boilerless EHI
 - JP52 Speed Fan

3 Transformer:
Unused wire to be capped.

4 DSHP only available on 115-208-230V applications.

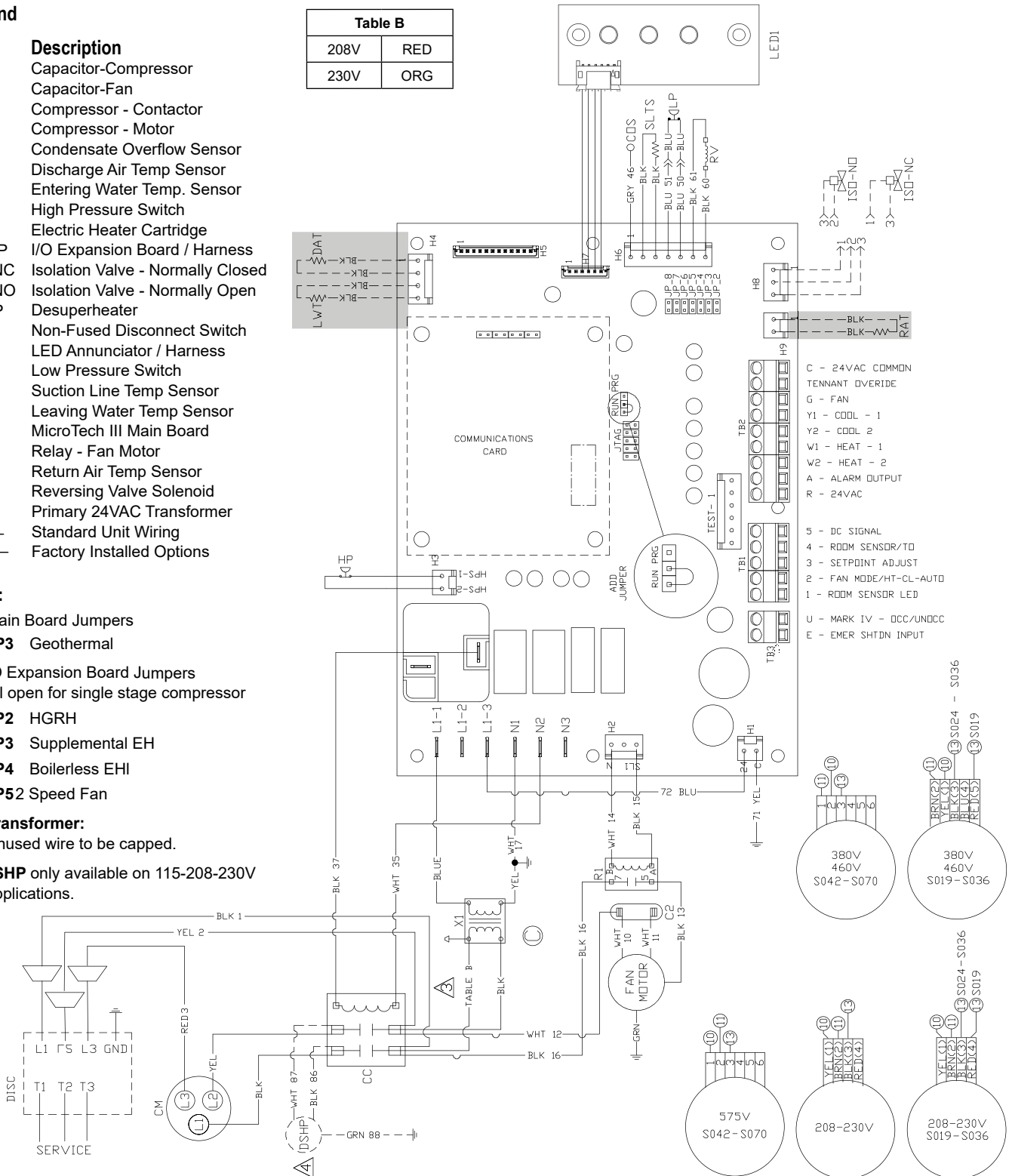

Note: Gray tint areas in wiring diagram: Units with factory installed communication module include Discharge Air Temperature (DAT) and Return Air Temperature (RAT) sensors shipped loose and are field installed. The Leaving Water Temperature (LWT) sensor is factory installed.

MicroTech III Controller with EC Motor and Optional I/O Expansion Module

Figure 30: 208-230/60 Hz/1-Phase

Drawing No. 910192979

Wiring diagrams are typical. For the latest drawing version refer to the wiring diagram located on the inside of the controls access panel of the unit.

Table B	
208V	RED
230V	BRN

Legend

Item	Description
C1	Capacitor-Compressor
CC	Compressor - Contactor
CM	Compressor - Motor
COS	Condensate Overflow Sensor
DAT	Discharge Air Temp Sensor
DISC	Non-Fused Disconnect Switch (Opt)
EB2	Exp Brd 2 - Fan Speed Cntl
HP	High Pressure Switch
IOEXP	I/O Expansion Board / Harness
ISO-NC	Isolation Valve - Normally Closed
ISO-NO	Isolation Valve - Normally Open
LED1	LED Annunciator / Harness
LED2	LED Annunciator / Harness
LP	Low Pressure Switch
LWT	Leaving Water Temp Sensor
MIII	MicroTech III Main Board
RAT	Return Air Temp Sensor
RV	Reversing Valve Solenoid
SLTS	Suction Line Temp Sensor
X1	Primary 24VAC Transformer
—	Standard Unit Wiring
---	Factory Installed Options

Notes:

- Main Board Jumpers
 - JP2** Shorted for cycling fan
 - JP3** Geothermal
 - JP8** Shorted for IO Board Comm
- IO Expansion Board Jumpers
 - All open for single stage compressor
- Transformer:**
 - Unused wire to be capped.

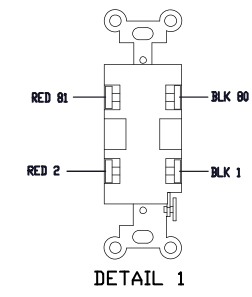
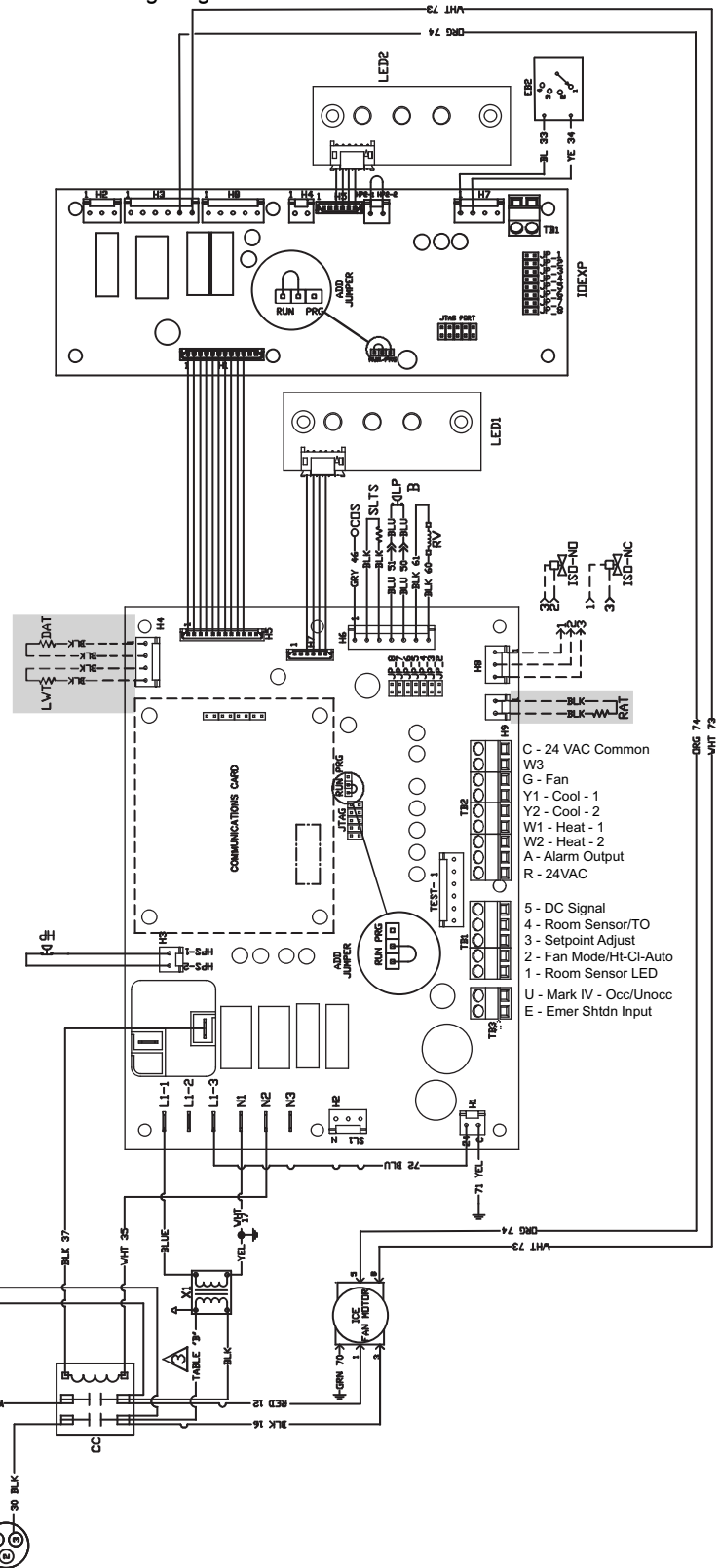

Note: Gray tint areas in wiring diagram: Units with factory installed communication module include Discharge Air Temperature (DAT) and Return Air Temperature (RAT) sensors shipped loose and are field installed. The Leaving Water Temperature (LWT) sensor is factory installed.

MicroTech III Controller with EC Motor, Electric Heat Coil with Optional I/O Expansion Module

Figure 31: 208-230/60 Hz/1-Phase

Drawing No. With Nidec EC Motor (910270623) and Genteq EC Motor Detail (910154305)

Wiring diagrams are typical. For the latest drawing version refer to the wiring diagram located on the inside of the controls access panel of the unit.

Table B	
208V	RED
230V	ORG

Legend

Item	Description
C1	Capacitor-Compressor
CC	Compressor - Contactor
CM	Compressor - Motor
COS	Condensate Overflow Sensor
DAT	Discharge Air Temp Sensor
DISC	Non-Fused Disconnect Switch (Opt)
EB2	Exp Brd 2 - Fan Speed Cntl
HP	High Pressure Switch
IOEXP	I/O Expansion Board / Harness
ISO-NC	Isolation Valve - Normally Closed
ISO-NO	Isolation Valve - Normally Open
LED1	LED Annunciator / Harness
LED2	LED Annunciator / Harness
LP	Low Pressure Switch
LWT	Leaving Water Temp Sensor
MIII	MicroTech III Main Board
RAT	Return Air Temp Sensor
RV	Reversing Valve Solenoid
SLTS	Suction Line Temp Sensor
IB	ECM Interface Board
IB-1	ECM Interface Board Connection 1
IB-2	ECM Interface Board Connection 2
X1	Primary 24VAC Transformer
—	Standard Unit Wiring
- - -	Factory Installed Options

Notes:

- Main Board Jumpers
 - JP2 Shorted for cycling fan
 - JP3 Geothermal
 - JP8 Shorted for IO Board Comm
 - IO Expansion Board Jumpers
 - All open for single stage compressor
- ⚠ Transformer:
Unused wire to be capped.

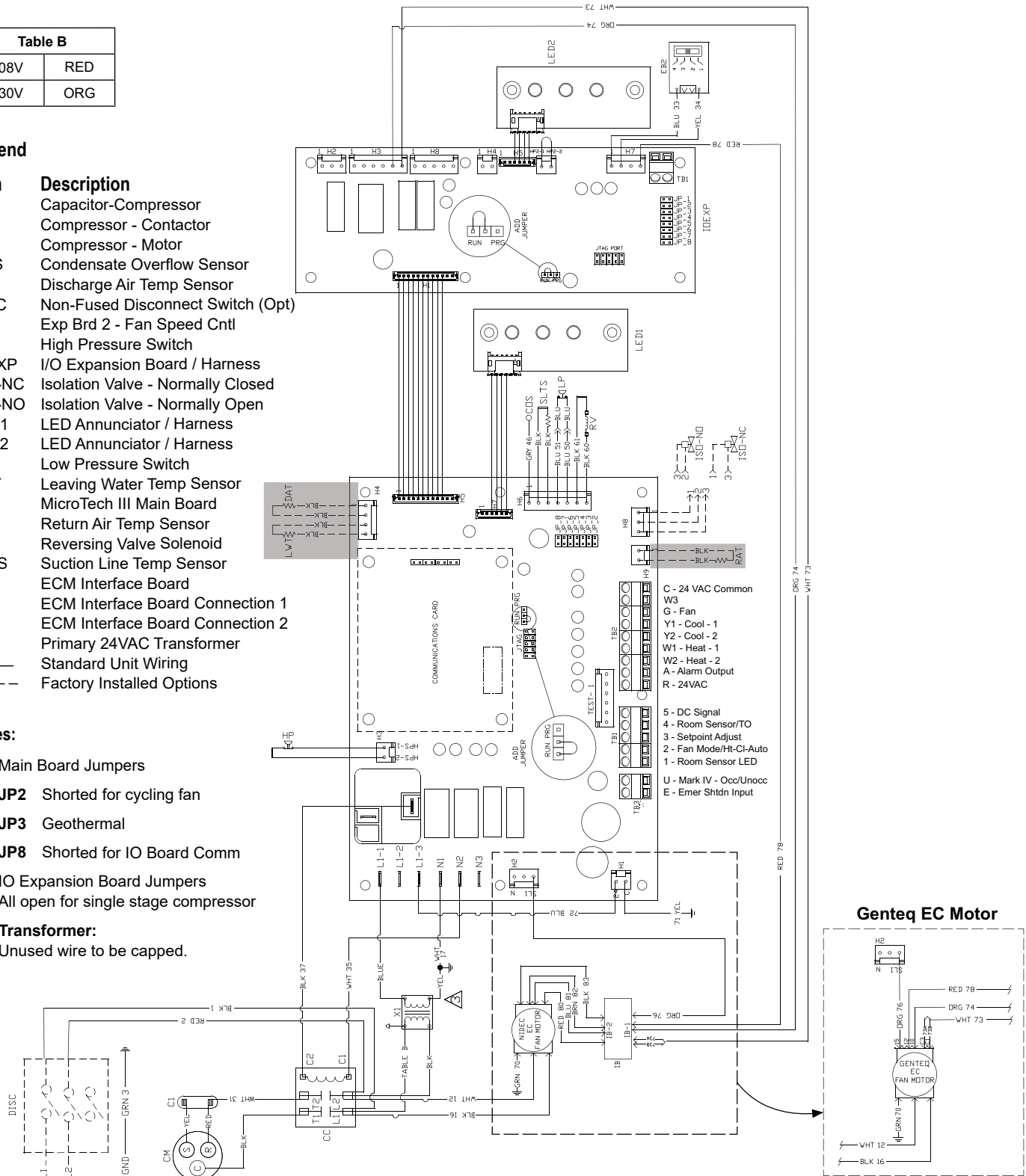

Note: Gray tint areas in wiring diagram: Units with factory installed communication module include Discharge Air Temperature (DAT) and Return Air Temperature (RAT) sensors shipped loose and are field installed. The Leaving Water Temperature (LWT) sensor is factory installed. Entering Water Temperature (EWT) sensor is included with ECM and/or Secondary Electric Heat.

MicroTech III Controller with EC Motor, HGRH and Optional I/O Expansion Module

Figure 32: 460/60/3-Phase

Drawing No. With Nidec EC Motor (910270631) and Genteq EC Motor Detail (910253864)

Wiring diagrams are typical. For the latest drawing version refer to the wiring diagram located on the inside of the controls access panel of the unit.

Table B	
460V	RED

Legend

Item	Description
CC	Compressor - Contactor
CM	Compressor - Motor
COS	Condensate Overflow Sensor
DAT	Discharge Air Temp Sensor
DISC	Non-Fused Disconnect Switch (Opt)
EB2	Exp Brd 2 - Fan Speed Cntl
HP	High Pressure Switch
HGRH	3-Way Valve Solenoid
ISO-NO	Isolation Valve - Normally Open
IOEXP	I/O Expansion Board / Harness
ISO-NC	Isolation Valve - Normally Closed
LED1	LED Annunciator / Harness
LED2	LED Annunciator / Harness
LP	Low Pressure Switch
LWT	Leaving Water Temp Sensor
MIII	MicroTech III Main Board
P1	24VAC Supply IO Expansion Board
RAT	Return Air Temp Sensor
RV	Reversing Valve Solenoid
SLTS	Suction Line Temp Sensor
TB1	Power Terminal Block
X1	Primary 24VAC Transformer
X2	Secondary 24VAC Transformer
—	Standard Unit Wiring
- - -	Factory Installed Options

Notes:

- Main Board Jumpers
 - JP3** Geothermal
 - JP8** Shorted for IO Board Comm
- IO Expansion Board Jumpers
 - JP2** HGRH
 - JP3** Supplemental EH
 - JP4** Boilerless EH
 - JP5** 2 Speed Fan

③ 460V Units with ECM Fan:
Motors Require a Neutral Wire.

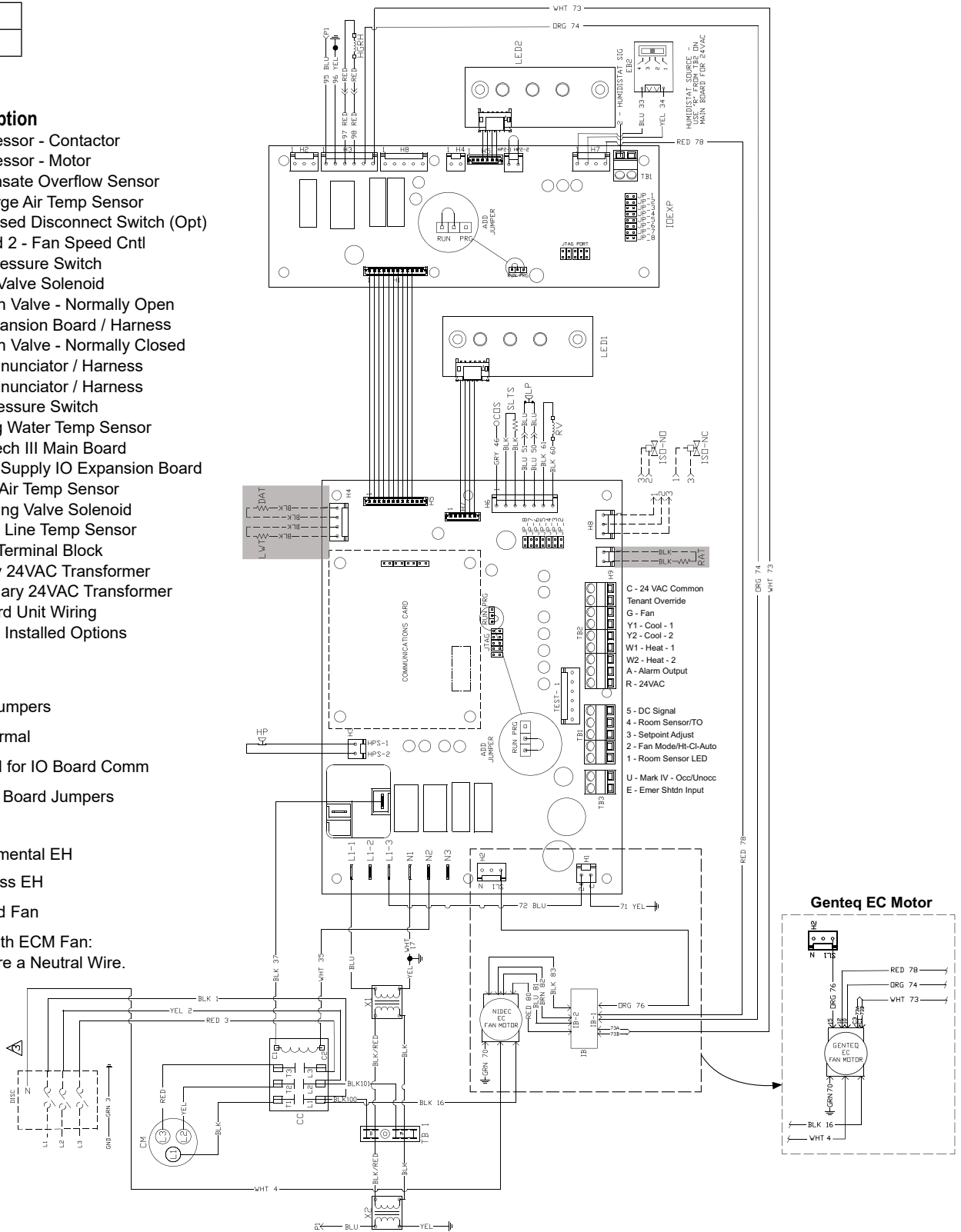

Note: Gray tint areas in wiring diagram: Units with factory installed communication module include Discharge Air Temperature (DAT) and Return Air Temperature (RAT) sensors shipped loose and are field installed. The Leaving Water Temperature (LWT) sensor is factory installed. Entering Water Temperature (EWT) sensor is included with ECM and/or Secondary Electric Heat.

MicroTech III Controller with PSC Motor, and I/O Expansion Module for Hot Gas Reheat Control (Unit Sizes 019-070)

Figure 33: 208-230/60/1-Phase

Drawing No. 669007101A

*Wiring diagrams are typical. For the latest drawing version refer to the wiring diagram located on the inside of the controls access panel of the unit.

Table B	
208V	RED
230V	ORG

Legend

Item	Description
C1	Capacitor-Compressor
C2	Capacitor-Fan
CC	Compressor - Contactor
CM	Compressor - Motor
COS	Condensate Overflow Sensor
DAT	Discharge Air Temp Sensor
EWT	Entering Water Temp Sensor
HP	High Pressure Switch
HTR	Electric Heater Cartridge
IOEXP	I/O Expansion Board / Harness
ISO-NC	Isolation Valve - Normally Closed
ISO-NO	Isolation Valve - Normally Open
HGRH	3-Way Valve Solenoid
P1	24 VAC Supply I/O Expansion Brd.
LED1	LED Annunciator / Harness
LED2	LED Annunciator / Harness
LP	Low Pressure Switch
SLTS	Suction Line Temp Sensor
LWT	Leaving Water Temp Sensor
MIII	MicroTech III Main Board
R1	Relay - Fan Motor
R2	Relay - Electric Heat
RAT	Return Air Temp Sensor
RV	Reversing Valve Solenoid
TB1	Power Terminal Block
X1	Primary 24 VAC Transformer
X2	Secondary 24 VAC Transformer
—	Standard Unit Wiring
- - - -	Optional Wiring (by others)

Notes:

- 3 Transformer:
Unused wire to be capped.

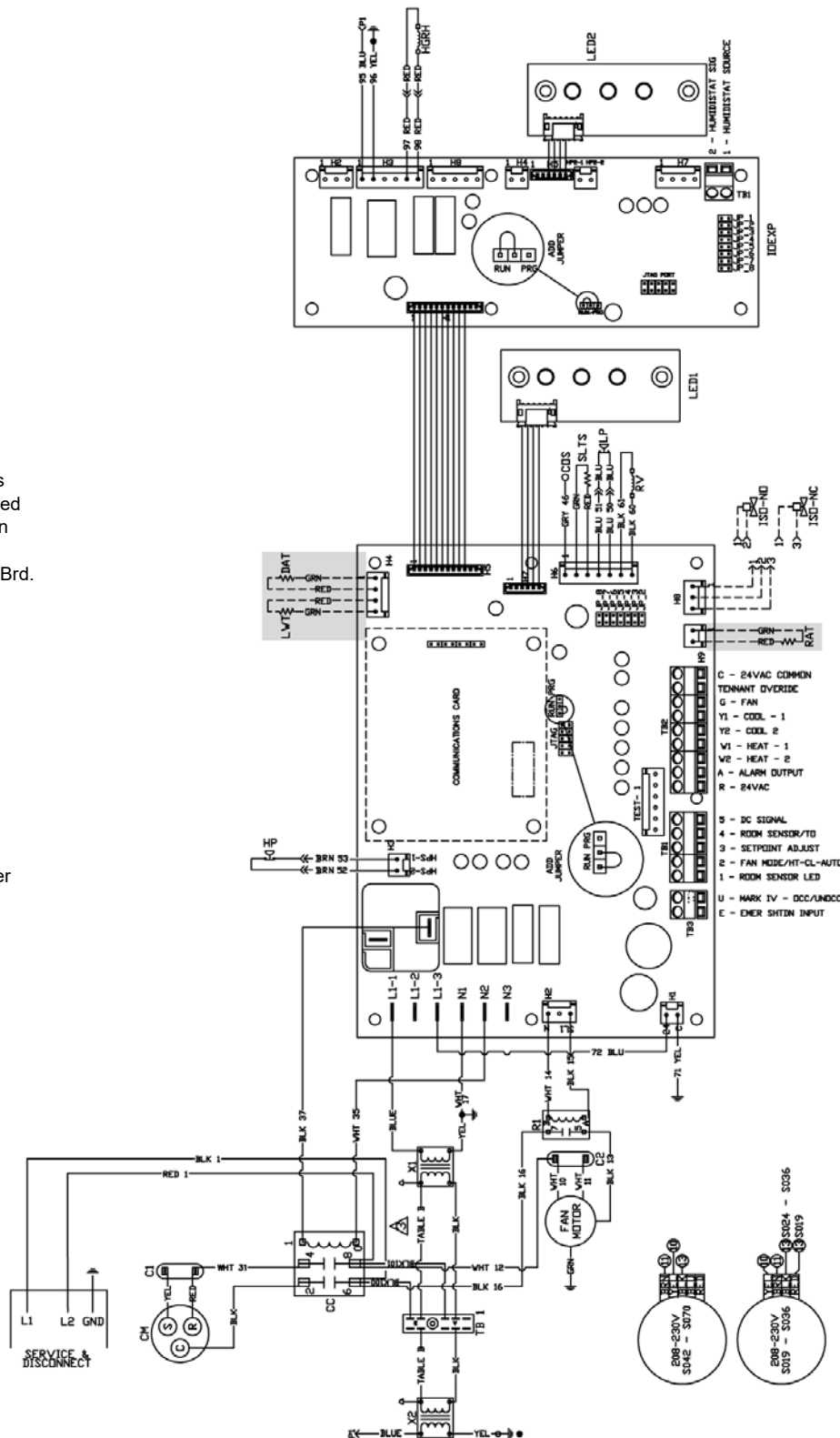

Note: Gray tint areas in wiring diagram: Units with factory installed communication module include Discharge Air Temperature (DAT) and Return Air Temperature (RAT) sensors shipped loose and are field installed. The Leaving Water Temperature (LWT) sensor is factory installed. Entering Water Temperature (EWT) sensor is included with ECM and/or Secondary Electric Heat.

General

Units shall be supplied completely factory assembled, piped, internally wired, fully charged with [R-410A, vertical unit sizes 009-070] and capable of operation with an entering water temperature range from [55°F to 110°F on models VFC] [30° to 110°F (-6.7°C to 49°C) on models VFW]. All equipment must be rated and certified in accordance with ARI / ISO 13256-1, ETL, ETL and have correct ARI / ISO and ETL labels mounted on side of the cabinets. Each unit shall be run tested at the factory. The installing contractor shall be responsible for furnishing and installing Daikin Water Source Heat Pumps as indicated on the plans and per installation instructions.

Casing and Cabinet

The cabinet shall be fabricated from heavy gauge G-60 galvanized sheet metal with interior surfaces lined with 1/2-inch thick, 1-1/2 lb. [1/2" thick coated glass fiber insulation] [3/8" thick closed-cell non-fibrous Rubatex IAQ insulation]. The insulation shall have a flame spread of less than 25 and a smoke developed classification of less than 50 per ASTM E-84 and UL 723. All fiberglass shall be coated and have exposed edges tucked under flanges to prevent the introduction of glass fibers into the air stream. All insulation must meet NFPA 90A requirements.

Units shall be configured in one of the following airflow arrangements:

- Left Return/Top Discharge
- Right Return/Top Discharge

Units shall have a factory-installed 1" duct flange on the discharge of the blower and must have a minimum of two access panels, one for the compressor compartment and one for the blower compartment. Unit shall have an insulated panel separating the blower compartment from the compressor compartment. Units are to ship with heavy metal brackets, rubber isolators, fasteners and washers to suspend and isolate the unit from the building.

Cabinets shall have separate openings and knockouts for entrance of line voltage and low voltage control wiring. Supply and return water connections shall be brass FPT fittings and shall be securely mounted flush to the cabinet corner post allowing for connection to a flexible hose without the use of a back-up wrench. Unit shall include a corrosion resistant polypropylene (PP) "dual sloped" drain pan with a drain connection being flush mounted to the unit casing. It is the installing contractor's responsibility to provide sufficient clearance so that units can be easily removed for servicing.

Filter Rack and Filters

Unit shall have a 1" (25 mm thick [throwaway] construction filter and a 1" factory-installed combination filter rack/return air duct collar. The filters shall be removable from either side of the unit.

Unit shall have a 2" (51mm) thick throwaway construction filter factory-installed when the user selects an optional 2" filter rack/return air duct collar. The 2" filter rack is designed to accommodate a 2" pleated filter.

A factory-installed 4-inch thick MERV 13 filter shall be available as a selectable option in a 4-inch, 4-sided combination filter rack with 3/4" return air duct collar and removable, tool-less access door with thumb screws.

Sound Attenuation Options

Sound Blanket

- For additional sound attenuation on unit sizes 024 - 070, a compressor blanket constructed from high performance Duracoustic sound material with superior sound absorption and deadening properties shall be provided. The sound rated material has a density of 1.5 lb./ft³ and is made from a loaded vinyl reinforced barrier and is embedded with 0.5" urethane foam

Sound Package

- 1-inch dual layer insulation on entire unit (Unit Sizes 007 - 015)
- 1-inch dual layer insulation in air handling section (Unit Sizes 019 - 070), 1/2-inch dual-density fiberglass insulation in the compressor section and compressor sound blanket (Unit Sizes 024 - 070).

Refrigerant Circuit

Units shall have a sealed refrigerant circuit, which includes a non-CFC depleting R-410A refrigerant [rotary (sizes 009-015), and scroll compressor (sizes 019 to 070)]. In addition each unit will have a thermostatic expansion valve, an aluminum fin and rifled copper tube refrigerant-to-air heat exchanger, a reversing valve and a water-to-refrigerant coaxial heat exchanger. The coaxial coils shall be made of [copper] [or optional cupronickel] and shall be deeply fluted to enhance heat transfer and minimize fouling and scaling. The coaxial coil shall have a working pressure of 500 psig on the waterside of the unit and 600 psig on the refrigerant side for all R-410A units.

Refrigerant metering shall be regulated by a thermostatic expansion valve (TXV) only. Reversing valve shall be four-way solenoid activated refrigerant valve, which fails in the cooling "dominant" operation. Safety controls include a high-pressure switch, a low-pressure switch (sizes 019 to 070 only) and a low refrigerant temperature sensor. Refrigerant gauge access fittings shall be factory installed on high and low pressure refrigerant lines to facilitate field service. Activation of any safety switch shall prevent the compressor from operating. Units shall be capable of being reset only by interrupting the power supply to the unit. Unit shall not be able to be reset from the wall thermostat.

Electric Heat Coils

The optional electric heat coil (5kW or 10kW) shall be factory installed inside the unit cabinet, be integral to the supply fan housing and be used as auxiliary or emergency heat.

Hot Gas Reheat Coil Option

The optional factory-installed hot gas reheat coil shall be used as part of a dehumidification operating sequence. The hot gas reheat coil shall be enabled when the space humidity level is above a user selectable set point. Typically, 50 to 55% RH. Hot gas shall be diverted to the reheat coil only when the unit is in the cooling mode of operation.

Motorized Isolation Valves

The optional 2-way motorized isolation valves shall be factory installed inside the compressor compartment. The valve actuator shall be factory wired to the MicroTech III controller and be controlled when there is a call for heating or cooling.

Drain Pan

The condensate pan shall be constructed of a corrosion resistant polypropylene (PP) to prevent corrosion and sweating. The bottom of the drain pan shall be sloped on two planes to provide complete drainage of water from the pan to meet IAQ requirements. The water source heat pump unit shall be supplied with standard solid-state electronic condensate overflow protection.

Fan and Motor Assembly

Units 6 tons and smaller shall have a direct drive centrifugal fan. The fan housing shall have a removable orifice ring to facilitate fan motor and fan wheel removal. The fan housing shall protrude through the cabinet to facilitate field supply duct connection. The standard fan motor shall be PSC type isolated from the fan housing and shall have internal thermal overload protection. Units above one ton shall have a terminal strip mounted on the fan motor to facilitate motor speed change. The fan and motor assembly must be capable of overcoming the external static pressures as shown on the schedule.

EC Motor Option

An EC motor shall be optional for unit sizes 007 thru 070. The EC motor shall deliver precise speed and economical performance regardless of system static pressure.

Option (009-012)

The fan motor shall be permanently lubricated, constant torque electronically commutated for improved operation. Field adjustable CFM settings shall be accomplished from a 4-position switch in the control box.

Option (015-070)

The fan motor shall be permanently lubricated, variable speed, constant CFM, electronically commutated for improved operation. Field adjustable CFM settings shall be accomplished from a 4-position switch in the control box. The constant CFM EC motor shall have the ability to reduce the CFM as the space temperature approaches the thermostat setpoint for improved dehumidification. Units with 460/60/3 power require the 4th wire neutral.

Electrical

A control box shall be located within the unit and shall contain controls for compressor, reversing valve and fan motor operation and shall have either, a 50VA or (optional) 75VA transformer and a terminal block for low voltage field wiring connections. Unit shall be name-plated to accept time delay fuses or HACR circuit breaker for branch over-current protection of the power source. Unit control system shall provide heating or cooling as required by the set points of the wall thermostat. The unit control scheme shall provide for fan operation simultaneous with compressor operation (fan interlock) regardless of the thermostat type. The unit shall be capable of providing an output signal to an LED on the thermostat or to a central monitoring panel to indicate a "fault" condition from the activation of any one of the safety switches. An optional 75VA transformer may be necessary

Solid-State Control System

MicroTech III Control System - Unit shall have a micro-processor-based control system. The unit control logic shall provide heating and cooling operation as required by the wall thermostat set point. The control system shall provide the following for stand-alone operation:

1. The use of standard non-programmable or programmable wall thermostats.
2. Fan operation simultaneous with the compressor (fan interlock) regardless of thermostat logic.
3. Time delay compressor operation.
4. Compressor short cycle protection of a minimum between 300 to 360 seconds before restart is possible.
5. Random unit start-up after coming off on unoccupied mode or after initial start up.
6. Single grounded wire connection for activation of the unoccupied or unit shutdown modes.
7. Night setback temperature setpoint input signal from the wall thermostat.
8. Override signal from wall thermostat to override unoccupied mode for 2 hours.
9. Brownout protection to suspend unit operation if the supply voltage drops below 80% of normal.

10. Condensate overflow protection to suspend cooling or dehumid operation in an event of a full drain pan.
11. Suspended compressor operation upon activation of the refrigerant pressure switch(es).
12. Cooling operation activated for 60 seconds upon activation of the low suction temperature - defrost cycle.
13. Method of defeating compressor, reversing valve and fan time delays for fast service diagnostics.
14. Remote reset - Provides means to remotely reset automatic lock-outs generated by high/low pressure faults and/or low temperature faults.
15. Fault Retry clears faults the 1st two times they occur within a 24-hour period and triggers automatic lock-out on 3rd fault.

MicroTech III Control with LONWORKS communication module – Unit shall have a microprocessor-based control system. The unit control logic shall communicate over a LONMARK communications network. The unit controller is factory programmed [LONMARK ® 3.4 certified Application Code the current standard for new applications] and tested with all the logic required to monitor and control heating and cooling operation. The controller sets the unit mode of operation, monitors water and air temperatures, and can communicate fault conditions via a LONMARK communications network. Units with the MicroTech III and LONWORKS communication module include return air, discharge air and leaving water temperature sensors. Space temperature sensor options include a set-point adjustment, tenant override button, and the capability of substituting the return air sensor with a wall-mounted room sensor.

Microtech III Control w/ BACnet Communication module – Unit shall have a microprocessor-based control system. The unit control logic shall communicate over a BACnet communications network. The BACnet communication module shall incorporate an Atmel ARM7 Thumb series MCU and be capable of supporting a full MSTP BACnet implementation. The microprocessor shall also support SPI compatible communications with the MCU of the Microtech III controller. The physical interface to a BACnet BAS network shall be through an industry standard RS-485 transceiver capable of existing on an RS-485 network of up to 64 nodes. The unit controller is factory programmed and tested with all the logic required to monitor and control heating and cooling operation. The controller sets the unit mode of opera-

tion, monitors water and air temperatures, and can communicate fault conditions via a BACnet communications network. Units outfitted with Microtech III and BACnet Communication modules include return air, discharge air and leaving water temperature sensors. Space temperature sensor options include a set-point adjustment, tenant override button, and the capability of substituting the return air sensor with a wall-mounted room temperature sensor.

Each communicating unit controller performs the following unit operations:

- Enable heating and cooling to maintain space temperature set point at the room sensor
- Enable fan and compressor operation
- Monitor all safety controls
- Monitor discharge and return air temperature
- Monitor leaving water temperature
- Relay status of all vital unit functions

Unit mounted LED annunciators aid in diagnosing unit operation by indicating the water source heat pump operating mode and alarm conditions. If there are no current alarm conditions, the annunciator board will indicate normal unit operating mode. If an alarm condition exists, the Microtech III unit controller will send the fault condition to the LED annunciator, which will assist in troubleshooting the unit. Heat pumps with the MicroTech III Unit Controller with a LONWORKS Communication Module is designed to be linked with a centralized Building Automation System (BAS) through a LONMARK communications network for centralized scheduling and management of multiple heat pumps.

Wall-mounted room sensors are available to control the heating and cooling operation of each MicroTech III Water Source Heat Pump.

Available room sensors include:

- Room Sensor with timed override button and LED;
- Room temperature sensor with timed-override button and set point adjustment (55 to 95 deg F);
- Room sensor with timed-override button and set point adjustment (-3 to +3 deg F);
- Room sensor (no options, sensor only).

Warranty

- An optional 1-year extended compressor warranty covers the compressor for 2 years from the date at which the unit ships from the factory.
- An optional 1-year extended refrigeration circuit warranty covers the entire refrigeration circuit and related components for 2 years
- An optional 1-year extended complete parts warranty covers all parts components for 2 years.
- An optional 4-year extended compressor warranty covers the compressor for 5 years from the date at which the unit ships from the factory.
- An optional 4-year extended refrigeration circuit warranty covers the entire refrigeration circuit and related components for 5 years
- An optional 4-year extended complete parts warranty covers all parts components for 5 years.

In addition to the above warranties an optional 1st year labor allowance is available.

When an extended 4 year complete parts warranty is selected, an optional 5 year labor allowance is available.

Field Installed Accessories

Wall Thermostat Options:

- Programmable Electronic Thermostat Two-stage heat/Two-stage cool, 7-day programmable. Sub base shall have system "Mode/Prog" and fan "Auto/On" switches. Thermostat shall have the option of an Optional Remote Sensor.
- Non-programmable, auto or manual changeover Two-stage heat/Two-stage cool, night setback override. Subbase shall have system "Cool/Off/Heat/Auto" and fan "Auto/On switches. Thermostat shall have the option of an Optional Remote Sensor.

Wall Temperature Sensor Options:

- Wall Sensor with timed-override button.
- Wall Sensor with timed-override button and set point adjustment (55 to 95 deg F), fan mode switch (auto/on), operational mode button (Heat/Cool/Auto) and status LED to display fault condition.
- Wall Sensor with timed-override button and set point adjustment (-3 to +3 deg F), fan mode switch (auto/on), operational mode button (Heat/Cool/Auto) and status LED to display fault condition.

Hose Kits:

Two fire-rated flexible hoses with ASTM ratings of Flame Spread 25, Fuel Contribution 25 and Smoke Density 50 for connection to unit and field piping. Hose shall be covered with stainless steel braiding to prevent damage.

Valve Options:

- Combination balancing and shutoff valve with adjustable memory stop.
- Optional 2-way, Normally Open (N.O.) or Normally Closed (N.C.) motorized valves.

Automatic Flow Hose Kit:

The automatic flow hose kit shall include an automatic flow control valve, two ball valves, two flexible hoses, a high flow Y-strainer, and may include a strainer blow-down and various other accessories. The automatic flow control valve shall be factory set to a rated flow, and shall automatically control the flow to within 10% of the rated value over a 40 to 1 differential pressure, operating range (2 to 80 PSID). Operational temperature shall be rated from fluid freezing, to 225°F. The valve body shall be constructed from hot forged brass UNS C37700 per ASTM B-283 latest revision.



Daikin Applied Training and Development

Now that you have made an investment in modern, efficient Daikin equipment, its care should be a high priority. For training information on all Daikin HVAC products, please visit us at www.DaikinApplied.com and click on Training, or call 540-248-9646 and ask for the Training Department.

Warranty

All Daikin equipment is sold pursuant to its standard terms and conditions of sale, including Limited Product Warranty. Consult your local Daikin Applied representative for warranty details. Refer to Form 933-430285Y. To find your local Daikin Applied representative, go to www.DaikinApplied.com.

Aftermarket Services

To find your local parts office, visit www.DaikinApplied.com or call 800-37PARTS (800-377-2787). To find your local service office, visit www.DaikinApplied.com or call 800-432-1342.

This document contains the most current product information as of this printing. For the most up-to-date product information, please go to www.DaikinApplied.com.

Products manufactured in an ISO Certified Facility.