

MAGNITUDE[®] WME-D

MAGNETIC BEARING OIL-FREE CENTRIFUGAL CHILLERS

Model WME-D

250 - 450 Tons (900 - 1600 kw) Cooling

3600 - 5300 MBH (1000 - 1550 kw) Heating



R-515B REFRIGERANT

60 Hz



Introduction **3**
 General Description 3
Components and Technology **4**
 Magnetic Bearing Compressor Motor 4
 Vessel Construction 4
 Protective Coatings 4
 Variable Frequency Drive 4
 MicroTech Controller 4
Electrical Data **5**
 Short Circuit Current Ratings 5
 Electrical Interference Filters 5
 Ground Fault Protection 5
 Field Power Wiring 5
 Main Breakers 6
 Wiring Schematics 7
Dimensional Drawings **13**
 Service Clearance 13
 Unit Dimensions 14
Installation Considerations **15**
 Operating Limits 15
 Location Requirements 16
 Water Piping System Design 16
System Applications **17**
 Variable Fluid Flow Rates and Tube Velocities 17
 Water Volume 17
 Reducing Evaporator Fluid Flow 17
 Reducing Condenser Fluid Flow 17
 Reducing Condenser Entering Water Temperature . 17
 Condenser Water Temperature Difference 18
Engineering Specifications **19**

Hazard Identification

 DANGER
Danger indicates a hazardous situation, which will result in death or serious injury if not avoided.
 WARNING
Warning indicates a potentially hazardous situations, which can result in property damage, personal injury, or death if not avoided.
 CAUTION
Caution indicates a potentially hazardous situations, which can result in minor injury or equipment damage if not avoided.
NOTICE
Notice indicates practices not related to physical injury.

©2024 Daikin Applied, Minneapolis, MN. All rights reserved throughout the world. This document contains the most current product information as of this printing. Daikin Applied Americas Inc. has the right to change the information, design, and construction of the product represented within the document without prior notice. For the most up-to-date product information, please go to www.DaikinApplied.com.

™® Magnitude, MicroTech, SiteLine, and Daikin Applied are trademarks or registered trademarks of Daikin Applied Americas Inc. The following are trademarks or registered trademarks of their respective companies: BACnet from American Society of Heating, Refrigerating and Air-Conditioning Engineers, Inc.; Echelon, LonWorks, LonMark, and LonTalk from Echelon Corporation; Modbus from Schneider Electric; and Windows from Microsoft Corporation.

Introduction

General Description

Daikin Applied Magnitude® Centrifugal Chillers are complete, self-contained, automatically controlled, liquid-chilling units featuring oil-free, magnetic bearing compressors. All Magnitude chillers are equipped with a single evaporator and a single condenser along with one compressor.

Magnitude chillers are designed for indoor, non-freezing installation only. The chillers uses refrigerant R-515B.

Only normal field connections such as water piping, relief valve piping, electric power, and control interlocks are required, thereby simplifying installation and increasing reliability. Necessary equipment protection and operating controls are included.

All Daikin Applied centrifugal chillers must be commissioned by a factory-trained Daikin Applied service technician. Failure to follow this startup procedure can affect the equipment warranty.

The standard limited warranty on this equipment covers parts that prove defective in material or workmanship. Specific details of this warranty can be found in the warranty statement furnished with the equipment.

Nomenclature

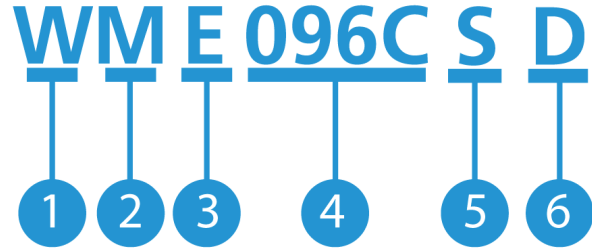

No.	Description
1	W = Water-cooled
2	M = Magnetic Bearing
3	E = Centrifugal Compressor
4	Model Code
5	S = Single
6	Design Vintage

Figure 1: WME-D Major Component Locations

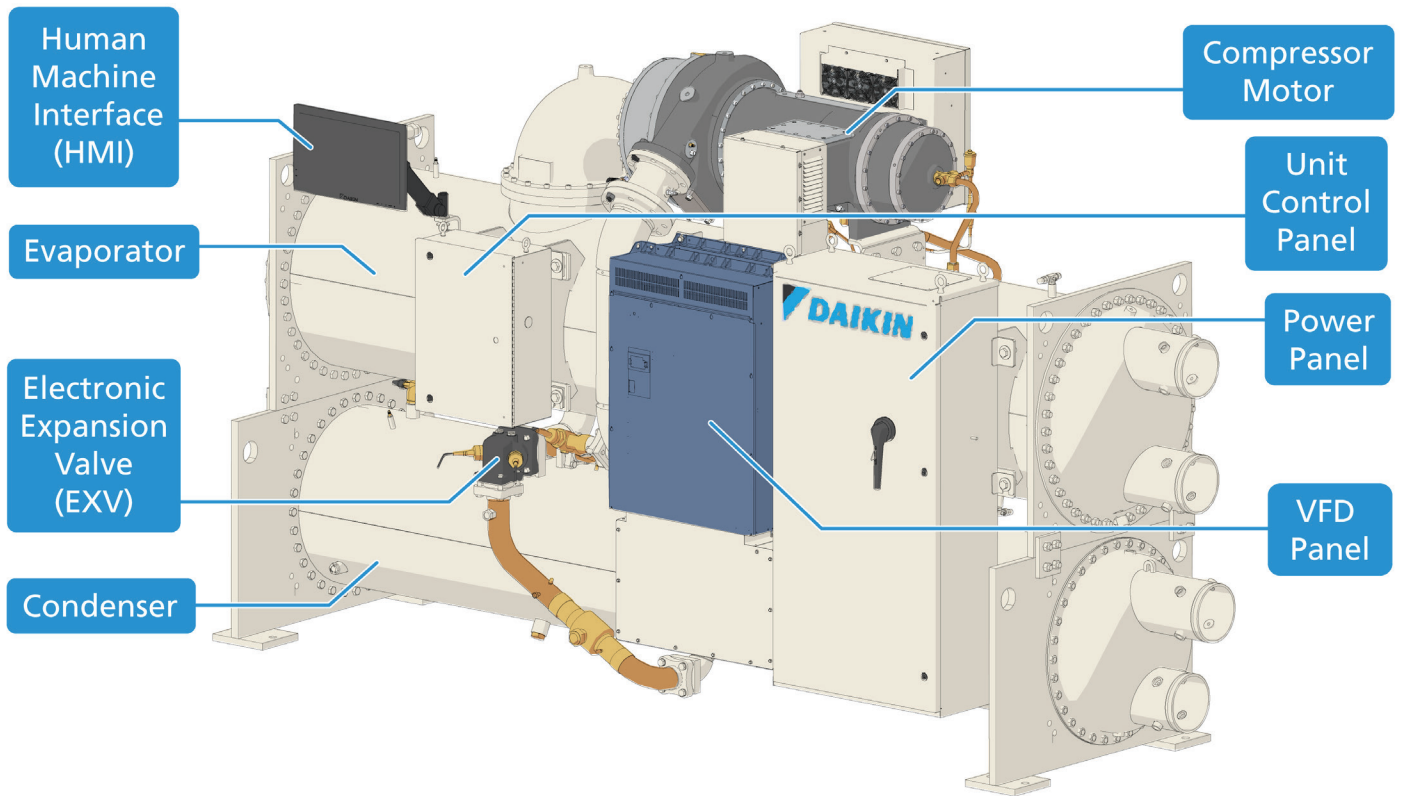

Components and Technology

The HVAC industry's next generation of water-cooled centrifugal chillers has arrived with the Daikin Applied Magnitude® WME-D chiller; incorporating a two-stage centrifugal compressor and unit-mounted variable frequency drive (VFD) with oil-free, magnetic bearing technology.

Magnetic Bearing Compressor Motor

WME-D's advanced compressor improves performance and decreases electrical requirements for up to 40% more energy savings than traditional fixed-speed centrifugal chillers. Utilizing real-time sensors and fewer moving components, the digital bearing control system maintains perfect compressor shaft alignment to produce superior performance and dependable, long-life operation.

Figure 2: Magnetic Bearing Compressor Motor

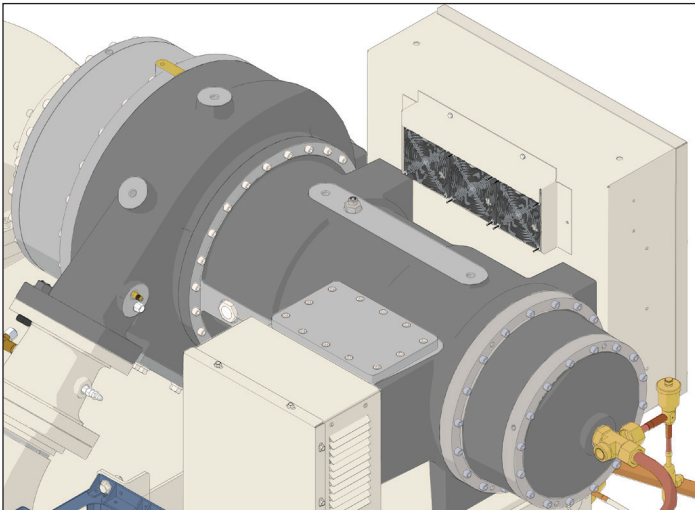

Vessel Construction

Manufactured to the world's highest safety and quality ASME standards to bear high refrigerant and water side design pressures. 150-300psig water side vessel construction options meet a variety of pump system and building configurations.

Protective Coatings

Various tube thicknesses and tube material types help to extend the life of the equipment in harsh water systems. Optional tube sheet and dished head or marine water box coating materials for the evaporator and condenser are also available to provide further protection. Optional metal alloy anodes protect the dished heads or marine water boxes from corrosive effects of harsh water and optional spacers are offered to connect an independent tube cleaning system.

Variable Frequency Drive

WME-D's unit-mounted VFD reduces in-rush current, generator size requirements, power consumption during off-design conditions, and utility surcharges with increased efficiency. The VFD is air-cooled, eliminating clogging and overheating issues that other chillers have when using condenser water that may become fouled.

Figure 3: Unit-Mounted VFD

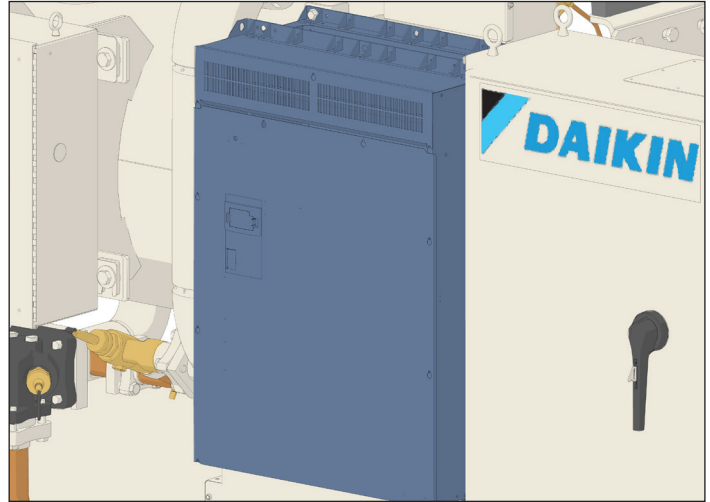

MicroTech Controller

WME-D chillers utilize MicroTech digital control electronics to proactively manage unit operation and provide control of external chilled water and cooling tower pumps. The compressor runs at the minimum speed necessary to maintain cooling capacity and lift (which decreases with lower condenser water temperatures), thus minimizing energy usage over the entire range of operating conditions. By constantly monitoring chiller status and real time data, the MicroTech controller will automatically take proactive measures to relieve abnormal conditions or shut the unit down if a fault occurs.

The WME-D chiller includes a regenerative power system that is used to provide power to the controls and bearings during a power loss event. When power is lost, the system extracts energy from the spinning motor. The power extracted from the rotor is fed back into the controls and bearings. As the power is extracted from the rotor, the shaft naturally slows down. Once the rotor is exhausted of its kinetic energy, and the shaft has reached a near zero speed, it gently touches down onto the backup bearings. The backup bearings maintain shaft position when the compressor is in an idle state and serve as a failsafe for the primary magnetic bearing system.

Additional smart features that optimize operating efficiency have been incorporated into our MicroTech controls:

- Cooling tower control including on/off, staging, and VFD
- Direct control of water pumps
- Chilled water reset
- Demand limit control

Electrical Data

Short Circuit Current Ratings

Short circuit current ratings (SCCR) options for power panels up to 100kA are available to allow for a variety of utility configurations and building codes compliance. The chiller SCCR rating is integral to the main circuit breaker and should be selected based on the available SCCR rating in the facility and electrical components in the chiller cabinet to ensure the maximum short circuit current an electrical component can safely withstand.

Table 1: Short Circuit Current Ratings

Motor Code	Voltage	Standard Panel SCCR	Optional High SCCR	Optional Ultra High SCCR
MK	460V - 480V	35-50 kA	65 kA	100 kA
	575V	25 kA	35 kA	50 kA

Electrical Interference Filters

Optional radio frequency/electro-magnetic interference (EMI) filters are a factory-installed, unit-mounted option that provides electromagnetic noise suppression for facilities with excessive noise in the electrical distribution power wiring before it enters other electronic components in the chiller. An optional, factory-installed, unit-mounted passive harmonic filter guarantees compliance with the IEEE 519 ratio-based maximum total demand distortion (TDD) when $I_{SC}/I_L > 20$. In electrically sensitive environments like hospitals or data centers, this harmonic filter is used to mitigate harmonic distortions produced from the VFD.

Ground Fault Protection

Ground fault protection is attached to the main circuit breaker that protects the chiller equipment from line-to-ground fault currents less than those required for conductor protection. An electronic trip long time, short time, instantaneous, ground (LSIG) module is attached to the breaker to adjust the LSIG fault from tripping and prevent upstream devices from doing so as well.

Field Power Wiring

The standard power wiring connection to Magnitude chillers is multi-point for dual compressor WME-D models. Power conduit entry will be at the top of the unit power panel; see [Figure 4](#) for general reference as power entry cover plate location will vary by unit configuration. Copper wiring must be used for power wiring. Refer to the unit nameplate and the Daikin Tools selection report for the correct electrical ratings.

⚠ DANGER

Qualified and licensed electricians must perform wiring. An electrical shock hazard exists that can cause severe injury or death.

Figure 4: Unit Power Connection Point

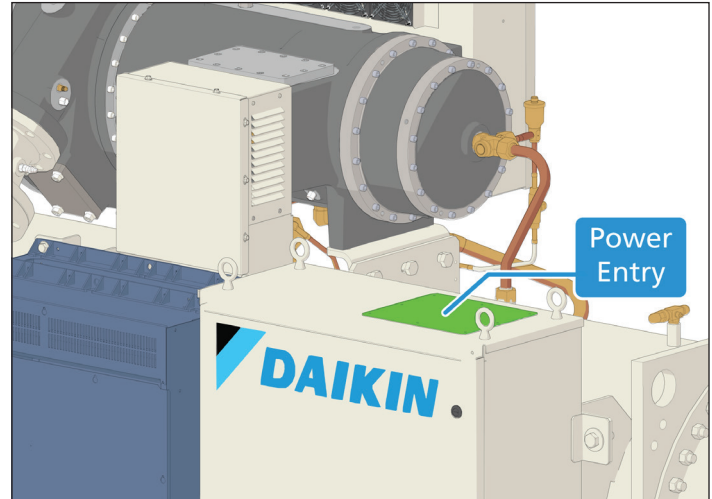

Factory-mounted and wired line reactors are standard. The field control wiring required varies depending on unit model. See the WME-D Field Wiring Schematic for wiring information. These wiring diagrams are also provided with the chiller.

NOTICE

Wiring, fuse, and wire size must be in accordance with the National Electrical Code® (NEC). The voltage to these units must be within $\pm 10\%$ of nameplate voltage (415V units must have voltage within -13% and $+6\%$ of nameplate voltage) and the voltage unbalance between phases must not exceed 2% . Since a 2% voltage unbalance will cause a current unbalance of 6 to 10 times the voltage unbalance per the current version of the NEMA MG-1 Standard, it is most important that the unbalance between phases be kept at a minimum.

⚠ CAUTION

Do not use power factor correction capacitors with WME-D chillers. Doing so can cause harmful electrical resonance in the system. Correction capacitors are not necessary since VFDs inherently maintain high power factors.

Main Breakers

Figure 5: Main Breakers

VFD Size	SCCR	Breaker	Frame Size	Trip Unit	LUG
FRN5200	35 kAIC	EATON 600 AMP, 600 TRIP SETTING	LD3600F	LES3600LSI	(2) 3TA603LDK
FRN5200	65 kAIC	EATON 600 AMP, 600 TRIP SETTING	HLD3600F	LES3600LSI	(2) 3TA603LDK
FRN5200	100 kAIC	EATON 600 AMP, 600 TRIP SETTING	LDC3600F	LES3600LSI	(2) 3TA603LDK
FRN5900	35 kAIC	EATON 800 AMP, 700 TRIP SETTING	MDL3800F	MES3800LSI	(6) TA800MA2
FRN5900	65 kAIC	EATON 800 AMP, 700 TRIP SETTING	HMDL3800F	MES3800LSI	(6) TA800MA2
FRN5900	100 kAIC	EATON 800 AMP, 700 TRIP SETTING	NGC312032E	MES3800LSI	(6) TA800MA2
FRN6500	35 kAIC	EATON 800 AMP, 800 TRIP SETTING	MDL3800F	MES3800LSI	(6) TA800MA2
FRN6500	65 kAIC	EATON 800 AMP, 800 TRIP SETTING	HMDL3800F	MES3800LSI	(6) TA800MA2
FRN6500	100 kAIC	EATON 1200 AMP, 800 TRIP SETTING	NGC312032E	MES3800LSI	(6) TA800MA2

Wiring Schematics

Figure 6: WME-D Unit Schematic

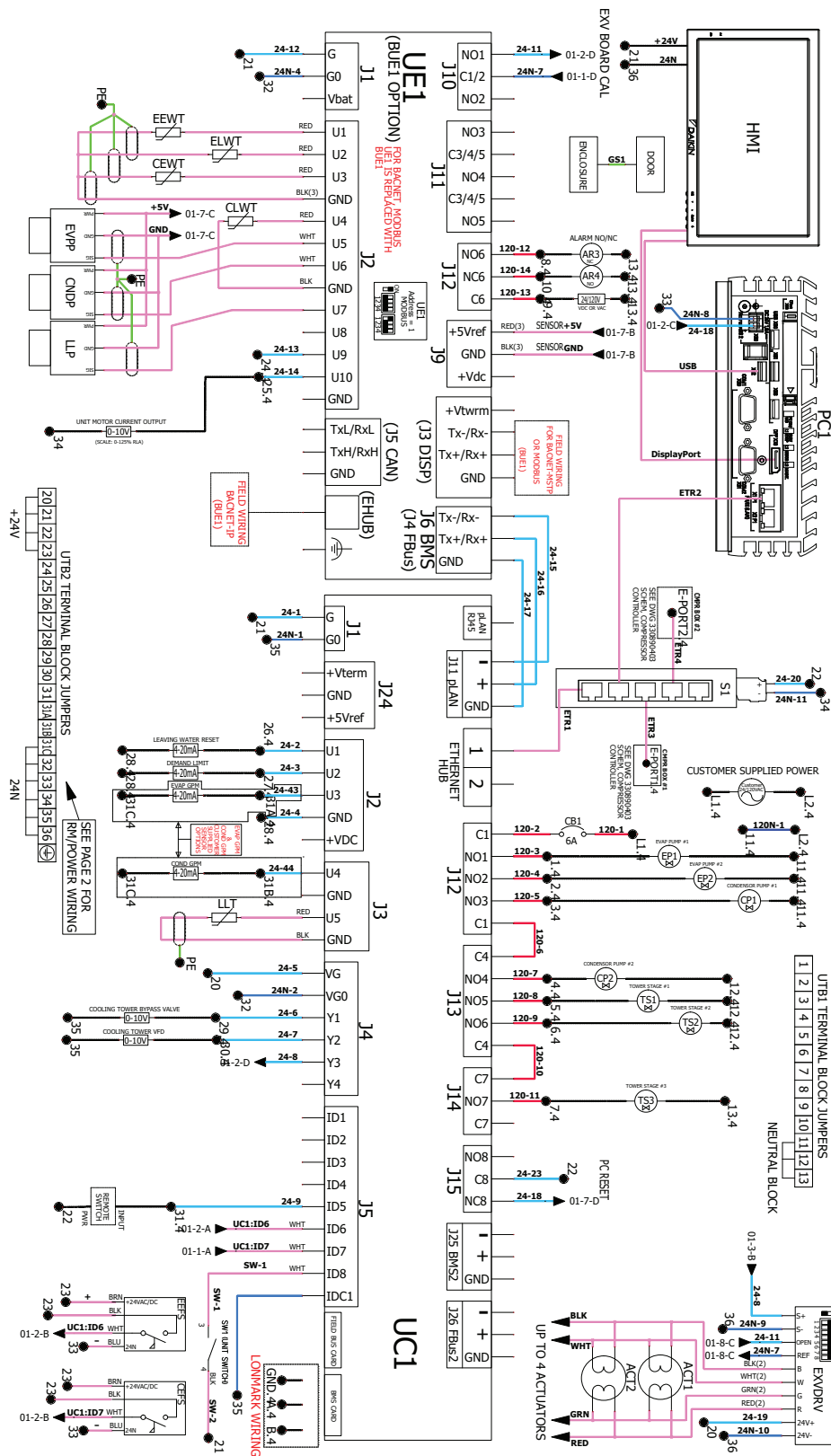
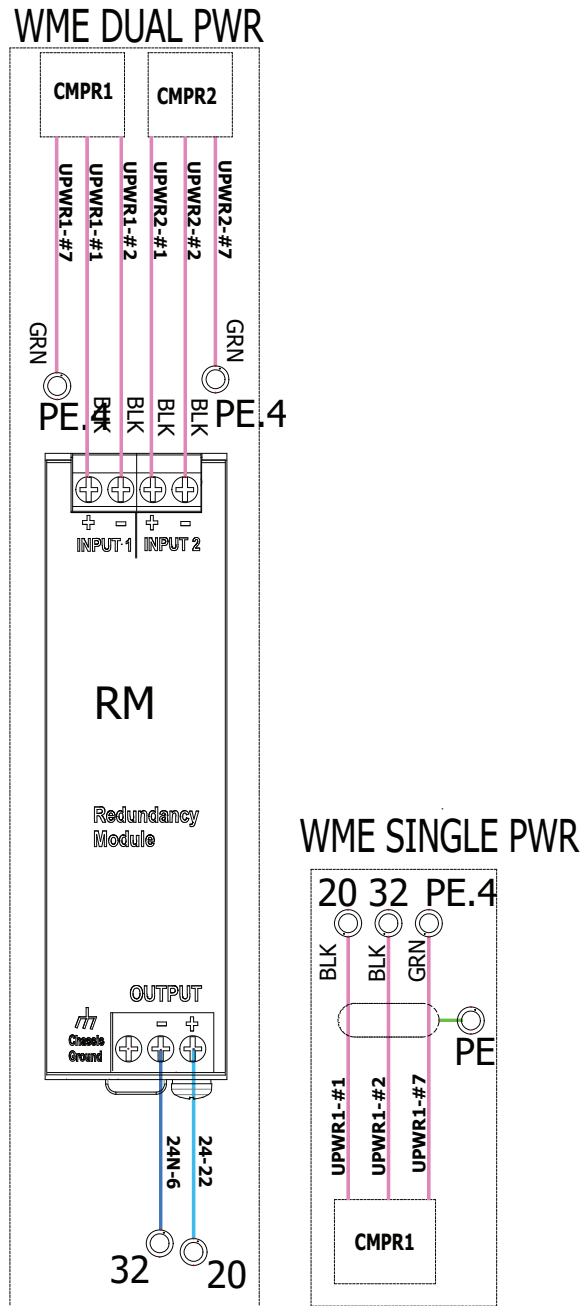

Figure 7: Power Cable Configuration (Standard 24V Power)



SCHEM, COMPRESSOR CONTROLLER
SEE DWG 336078103

Figure 8: Power Cable Configuration (RapidRestore Option)

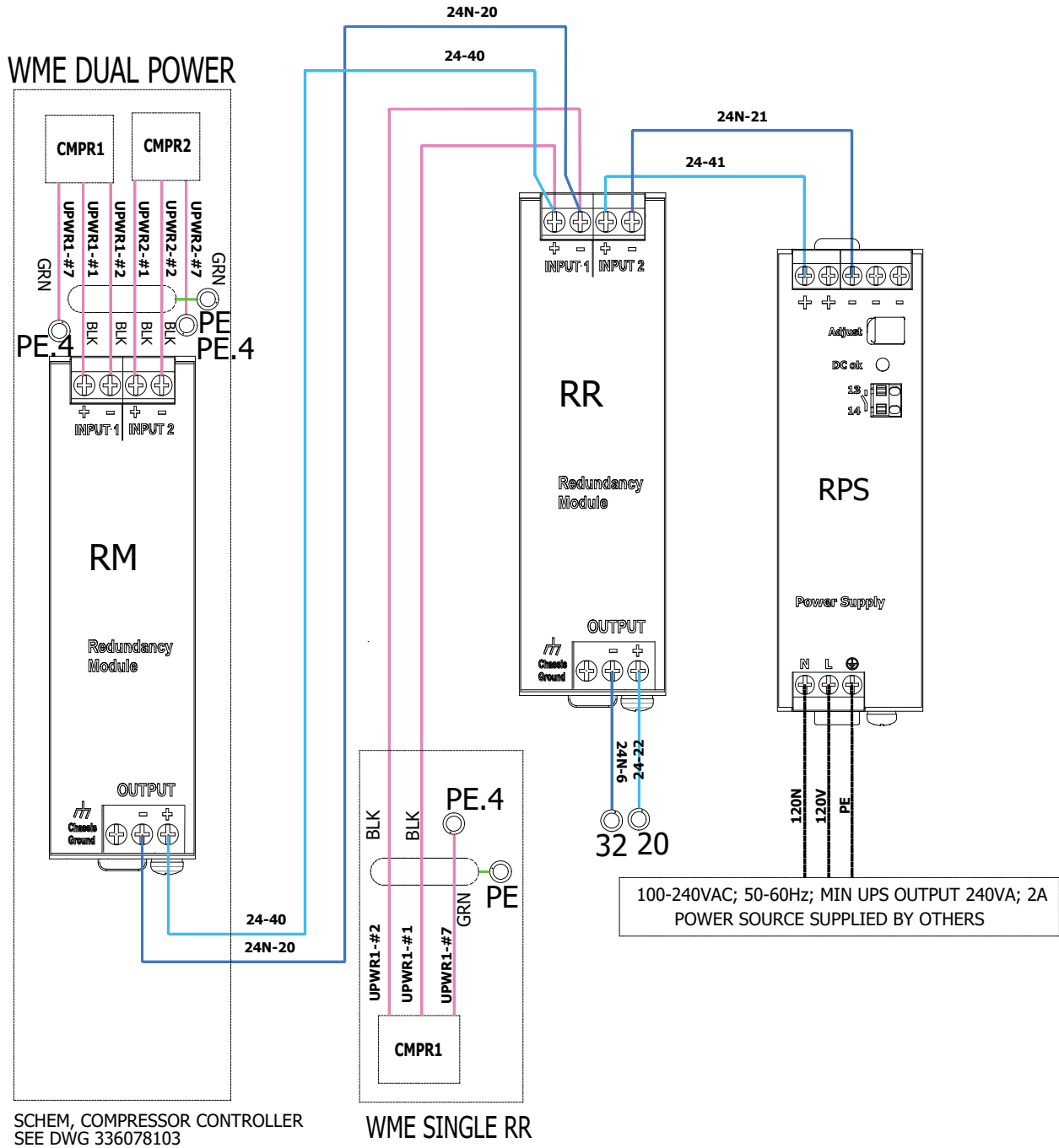

Figure 9: WME-D Compressor Schematic

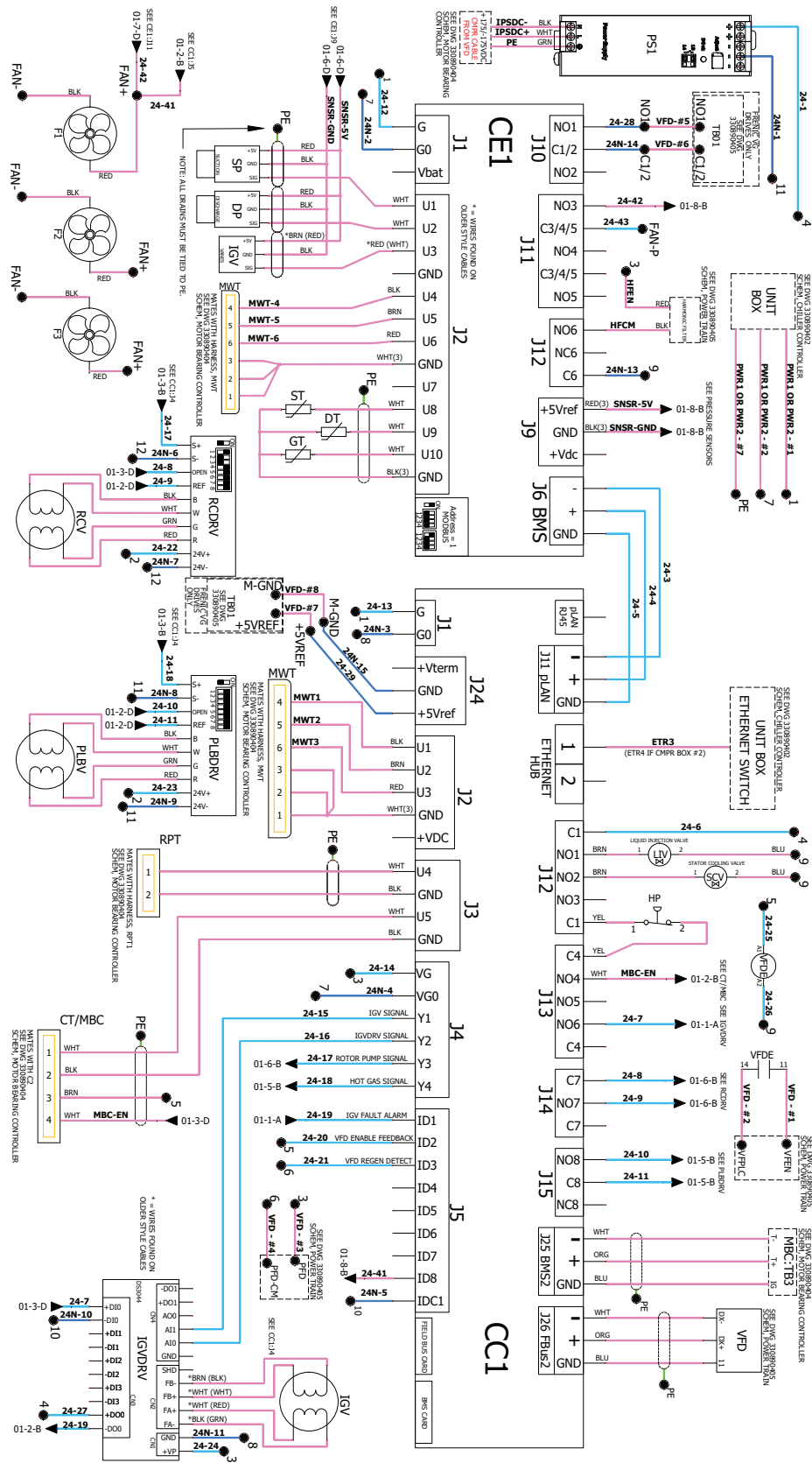

Figure 10: Motor Bearing Controller Schematic

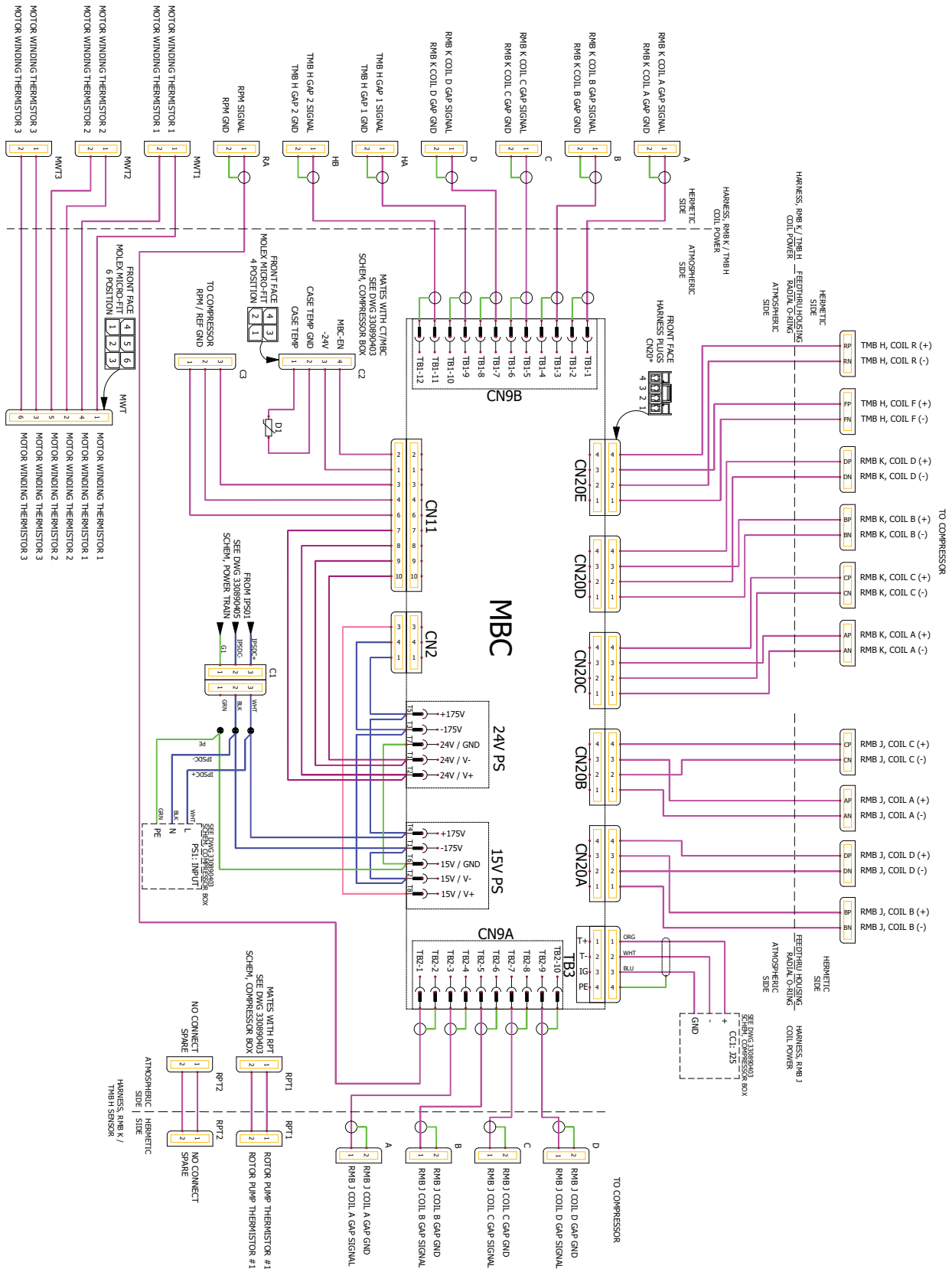
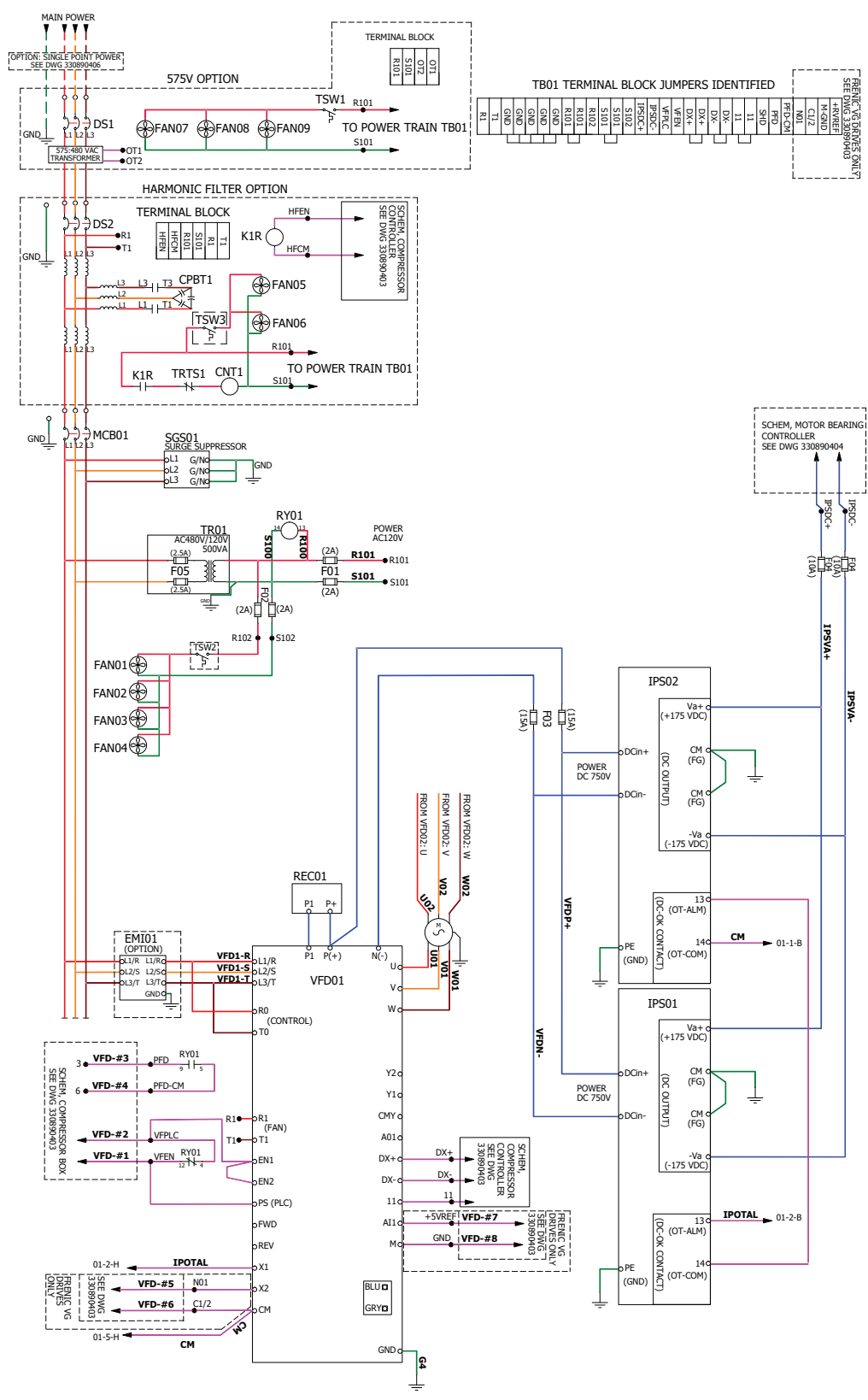

Figure 11: Power Train Schematic



Dimensional Drawings

Service Clearance

Figure 12: Minimum Service Clearance

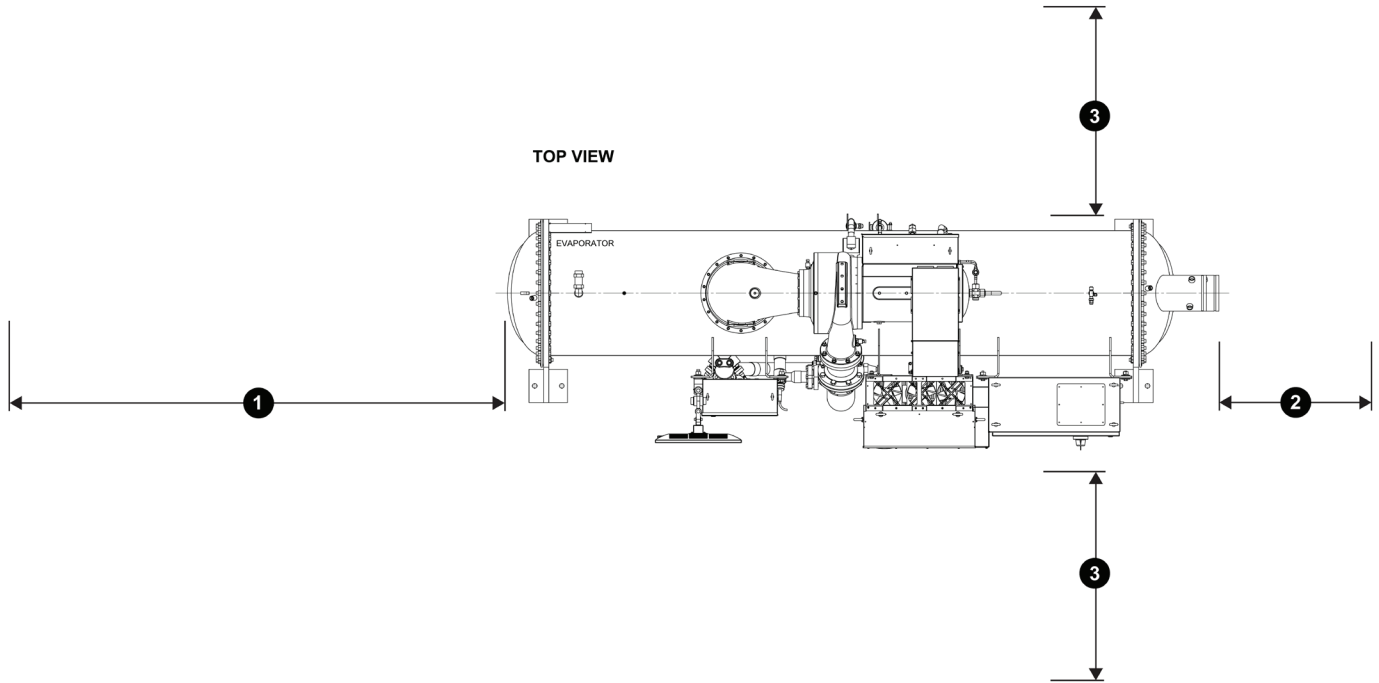

Table 2: Minimum Clearance

Number	Minimum Clearance
1	13 ft
2	3 ft
3	4 ft

The unit must be placed in an area that allows for adequate clearance around the unit. See Table 2 for clearance requirements around the sides of the chiller. Doors and removable wall sections can be utilized to meet these clearance requirements. There must be a minimum 3-foot clearance above the top of the chiller. The U.S. National Electrical Code® (NEC) or local codes can require more clearance in and around electrical components and must be checked for compliance.

Drawing Notes

- Final connections must allow for +/- 1/2 inch (0.5 inch, 12.7 mm) manufacturing tolerances.
- 2.00-inch ANSI class 150 flange evaporator and condenser rupture disks must be piped per ANSI/ASHRAE 15.
- Minimum Clearances (See Figure 12):
 - Check local codes for any additional clearance requirements.

- Installation layout should be designed by qualified personnel familiar with local codes.
 - Hinged type waterboxes may require more clearance. Consult a Daikin Applied representative for details.
- Unit shown has standard right-hand water connections. Left-hand connections are available for either vessel. ANSI-flanged nozzle connections are available upon request. When using ANSI-flanged connections, add 0.5 inch (13 mm) to each flanged end.
 - Dimensions shown are for units (evaporator/condenser) with standard design pressures. The waterside design pressure is 150 psi (1034 kPa). Consult the factory for unit dimensions with higher design pressures.
 - Unit vibration isolator pads are provided for field installation and when fully loaded are 0.25 inches (6 mm) thick.
 - 3.50-inch (89 mm) diameter lifting holes are provided.
 - The shipping skid adds 4.00 inches (105 mm) to the overall unit height.
 - If main power wiring is brought up through the floor, this wiring must be outside the envelope of the unit.
 - The unit is shipped with a full operating charge of refrigerant except with the "Partial Disassembly" knockdown option.
 - Power landing panel is on the side of the cabinet.

Unit Dimensions

Figure 13: Representative WME-D Dimensional Drawing

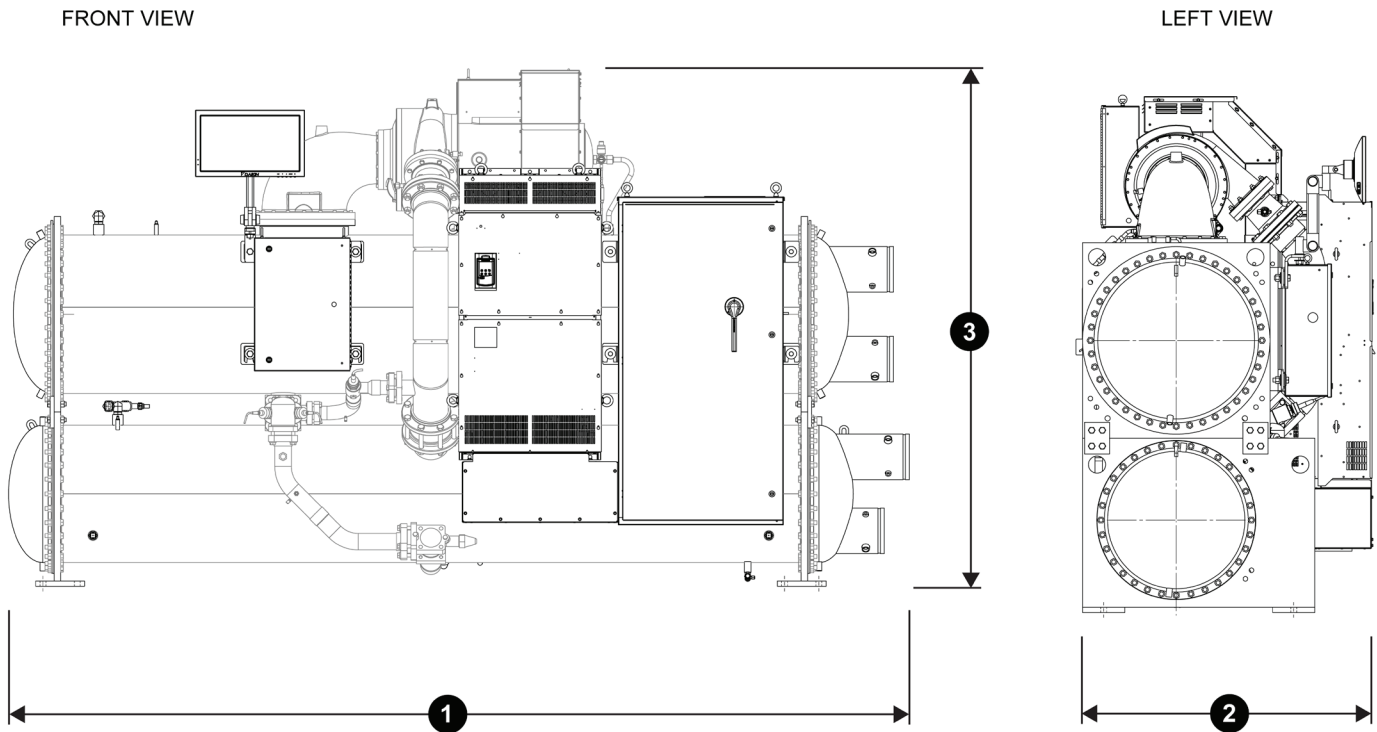

Table 3: WME-D Overall Dimensions

Model ¹	Heat Exchanger	Dished Waterbox Heads Length ²	Marine Waterbox Heads Length ²	Width ³	Height ³
		1	1	2	3
WME096CS	E3012/C2612	170.6 in	189.8 in	55.4 in	95.6 in

NOTE 1: Unit configuration may be different than illustrated. Refer to certified drawings for specific configuration/dimensions.

NOTE 2: Unit length represents 2 pass, 150 psi water box configuration with grooved connections.

NOTE 3: Unit height and width represents standard configuration.

Installation Considerations

Operating Limits

Table 4: Operating/Standby Limits

Acceptable Temperatures (WME-D) ¹			R-515B	
Condition	Component	Description	Min Temp °F (°C)	Max Temp °F (°C)
Standby	Evaporator	Water	35 (1.7)	140 (60)
		Water w/ Antifreeze ²	35 (1.7)	140 (60)
	Equipment Room	Air w/ Water in Vessels ⁴	34 (1.1)	140 (60)
		Air w/ no Water in Vessels ⁴	-25 (-31.6)	140 (60)
Startup	Evaporator	Water	35 (1.7)	90 (32.2)
		Water w/ Antifreeze ²	35 (1.7)	90 (32.2)
	Condenser	Water	40 (4.4)	120 (48.9)
	Equipment Room	Air ^{4,5}	34 (1.1)	104 (40)
Operating	Evaporator	Entering Water	35 (1.7)	90 (32.2)
		Leaving Water ³	35 (1.7)	70 (21.1)
		Entering Water w/ Antifreeze ²	35 (1.7)	90 (32.2)
		Leaving Water w/ Antifreeze ²	35 (1.7)	70 (21.1)
	Condenser	Entering Water	40 (4.4)	120 (48.9)
		Leaving Water ³	50 (10)	126 (52.2)
	Equipment Room	Air ^{4,5}	34 (1.1)	104 (40)
NOTES:				
1	Contact a Daikin Applied representative for performance at specific operating conditions, as some limits depend on unit configuration			
2	Antifreeze temperature limits must have appropriate glycol concentration			
3	Allowable leaving fluid temperatures depend on Saturation Temperature			
4	5%-95% relative humidity, non-condensing			
5	For non-conditioned equipment rooms please contact factory for maximum dew point, limits may depend on specific selection.			

Location Requirements

WME-D chillers are intended only for installation in an indoor or weather protected area consistent with the NEMA 1 rating on the chiller, controls, and electrical panels, and not accessible to the general public. For installation locations in seismic zones greater than category D, please contact factory.

Water Piping System Design

WARNING

Polyolester Oil, commonly known as POE oil is a synthetic oil used in many refrigeration systems, and may be present in this Daikin Applied product. POE oil, if ever in contact with PVC/CPVC, will coat the inside wall of PVC/CPVC pipe causing environmental stress fractures. Although there is no PVC/CPVC piping in this product, please keep this in mind when selecting piping materials for your application, as system failure and property damage could result. Refer to the pipe manufacturer's recommendations to determine suitable applications of the pipe.

Field installed water piping to the chiller must include:

- air vents at the high points.
- a cleanable water strainer upstream of the evaporator and condenser inlet connections.
- a flow proving device for both the evaporator and condenser to prevent freeze up. Flow switches, thermal dispersion switches, or Delta-P switches can be used. Note that flow switches are factory installed. Additional flow switches can be used only if they are connected in series with the ones already provided.
- sufficient shutoff valves to allow vessel isolation. The chiller must be capable of draining the water from the evaporator or condenser without draining the complete system.

It is recommended that field installed water piping to the chiller include:

- temperature sensors at the inlet and outlet connections of both vessels.
- water pressure gauge connection taps and gauges at the inlet and outlet connections of both vessels for measuring water pressure drop.

Piping must be supported to eliminate weight and strain on the fittings and connections. All evaporators and condensers have OGS-type grooved water connections (adhering to Standard AWWA C606) or optional flange connections. The installing contractor must provide matching mechanical connections. Chilled water piping must be adequately insulated.

NOTICE

This product, in its standard configuration, is equipped with a shell and tube evaporator with carbon steel shell and copper tubes. The water or other fluid used in contact with the wetted surfaces of the heat exchangers must be clean and non-corrosive to the standard materials of construction. Daikin Applied makes no warranty as to the compatibility of fluids and materials. Non-compatible fluids may void the equipment warranty. If the compatibility of the fluid with the standard materials of construction is in question, a professional corrosion consultant should administer the proper testing and evaluate compatibility.

System Applications

Variable Fluid Flow Rates and Tube Velocities

Many chiller system control and energy optimization strategies require significant changes in evaporator water flow rates. The Magnitude chiller line is well suited to take full advantage of these energy saving opportunities using different combinations of shell sizes, number of tubes, and pass arrangements.

Both excessively high and excessively low fluid flow rates should be avoided. Excessively high fluid flow rates and correspondingly high tube velocities will result in high fluid pressure drops, high pumping power, and potential tube erosion or corrosion damage. Excessively low fluid flow rates and correspondingly low velocities should also be avoided as they will result in poor heat transfer, high compressor power, sedimentation, and tube fouling.

Water Volume

All chilled water systems need adequate time to recognize a load change to avoid short cycling of the compressors or loss of control. The potential for short cycling usually exists when the building load falls below the minimum chiller plant capacity or on close-coupled systems with very small water volumes. Some of the things the designer should consider when looking at water volume are the minimum cooling load, the minimum chiller plant capacity during the low load period and the desired cycle time for the compressors.

Assuming that there are no sudden load changes and that the chiller plant has reasonable turndown, a rule of thumb of “gallons of water volume equal to two to three times the chilled water gpm flow rate” is often used. A properly designed storage tank should be added if the system components do not provide sufficient water volume.

Reducing Evaporator Fluid Flow

Several popular chiller plant control practices — including Variable Primary Flow systems — advocate reducing the evaporator fluid flow rate as the chiller capacity is reduced. This practice can significantly reduce the evaporator pumping power while having little effect on chiller energy consumption. The Magnitude WME-D chillers— with their wide range of shell, tube, and pass combinations— are ideal for application in variable evaporator flow systems as long as the minimum and maximum tube velocities are taken into consideration when selecting the chiller. If it is decided to vary the evaporator water flow rate, the rate of change should not exceed the minimum or maximum velocity limits. Additionally, the rate of change should not exceed 50% per minute.

Reducing Condenser Fluid Flow

Several popular chiller plant control practices also advocate reducing the condenser fluid flow rate as the chiller load is reduced. This practice can significantly reduce the condenser pumping power, but it may also have the unintended consequence of significantly increasing compressor power since the leaving condenser water temperature is directly related to compressor lift and power. The higher compressor power will typically be larger than the condenser pumping power reduction and will result in a net increase in chiller plant energy consumption. Therefore, before this strategy is applied for energy saving purposes it should be extensively modeled or used in an adaptive chiller plant control system which will take into account all of the interdependent variables affecting chiller plant energy. If it is decided to use variable condenser fluid flow, the model WME-D chiller can operate effectively as long as the minimum and maximum tube velocities are taken into consideration when selecting the chiller.

Reducing Condenser Entering Water Temperature

As a general rule, a 1°F (0.5°C) drop in condenser entering water temperature will reduce chiller energy consumption by two percent. Cooler water lowers the condensing pressure and reduces compressor work. One or two degrees can make a noticeable difference. The incremental cost of a larger tower can be small and provide a good return on investment. When the ambient wet bulb temperature is lower than design, the entering condenser water temperature of Magnitude WME-D chillers can be lowered to improve chiller performance. Magnitude WME-D chillers can start and run with very low entering condenser water temperatures. The WME-D chillers can also start and maintain operation with inverted conditions, meaning the entering condenser water temperature can be lower than the leaving chilled water temperature. Depending on local climatic conditions, using the lowest possible entering condenser water temperature may be more costly in total system power consumed than the expected savings in chiller power would suggest, due to the excessive fan power required. The trade-off between better chiller efficiency and fan power should be analyzed for best overall system efficiency. The Energy Analyzer™ II program (available from your Daikin Applied sales representative) can optimize the chiller/tower operation for specific buildings in specific locales.

Condenser Water Temperature Difference

The industry standard of 3 gpm/ton or about a 9.5°F (5.3°C) delta-T works well for most applications.

Condenser Water Temperature Control

Condenser water control is an important consideration in chiller plant design since condenser water temperature will directly impact chiller operation and efficiency. When the ambient wet bulb temperature is lower than peak design, the entering condenser water temperature from the cooling tower can be allowed to fall, improving chiller performance. However, operational issues may occur when the condenser water temperatures are either too high or too low. The WME-D chiller provides several options to assist the chiller plant designer in providing the optimum control of condenser water temperature

Cooling Tower Control

Control of the cooling tower is required to maintain stability and avoid operational issues. This can be achieved through a BAS or by using the MicroTech controller. For systems utilizing a common condenser water loop for multiple purposes, the BAS contractor must provide the control but use of the MicroTech output signal is still recommended. The preferred cooling tower control utilizes a variable speed fan. MicroTech will provide a control signal to determine the proper fan speed. It can also control up to three stages of fan cycling. Note that fan cycling can cause cooling tower water temperature to fluctuate as fans stage on/off, potentially adding instability to the system. Special consideration must be given to starting the chiller when cold condenser water is present, such as with inverted starts or changeover from free (tower) cooling to mechanical cooling. It is required that some method be used to control the condenser water to maintain proper head pressure as indicated by the MicroTech controller. Acceptable methods are outlined below and each of these options can be controlled by the MicroTech or through a BAS utilizing the MicroTech output signals.

1. **Three-Way Bypass Valve Operation** A traditional method for building condenser pressure at startup with colder condenser water is with the use of a three-way bypass valve. The device blends warmer water leaving the condenser with cooler water from the cooling tower at the condenser inlet. The bypass valve position will change until full flow from the tower to the condenser is obtained. The MicroTech provides only the valve position control signal. Main power to drive the valve's actuator must be provided by the installer. The three-way valve should be located close to the chiller within the equipment room to minimize the volume of water.
2. **Two-Way Valve Operation** Another condenser control method is to use a modulating two-way control valve located on the outlet connection of the condenser. The valve will be nearly closed at startup to restrict water flow, which keeps generated heat in the condenser until an acceptable minimum condenser pressure is reached. As heat builds, the valve will open slowly until a full flow

condition from the cooling tower is established. A separate power source is required to provide power to the valve actuator.

3. **VFD Operating with a Condenser Water Pump** A third method of condenser control for startup is utilizing a variable frequency drive with the condenser water pump. The speed will change as directed by the MicroTech output signal until design flow is reached. Speed adjustments may be required during the initial chiller startup as determined by the service technician.

NOTICE

Not using the MicroTech logic to control valves and variable frequency drives may result in system instability, capacity reduction, and issues starting the chiller with cold condenser water temperature.

Condenser Pump Sequencing

It is recommended to utilize the logic built into the MicroTech controller to start the condenser pump. MicroTech has the capability to operate a primary pump and a secondary standby pump. The condenser water flow should be stopped when the chiller shuts off. This will conserve energy and prevent refrigerant from migrating to the condenser.

Water Side Economizer Cycle Operation

Water side economizers are commonly used for ASHRAE 90.1 compliance and energy savings. This system utilizes a heat exchanger external to the chiller when cold cooling tower water is available to provide cooling. The most common system has a heat exchanger used in conjunction with the chiller's evaporator. The BAS contractor will need to provide controls for the heat exchanger including isolation valves and temperature control. The BAS contractor will also need to control the isolation valves for the chiller. It is important to use slow-acting type valves to prevent rapid changes in system flows. Changeover from economizer cooling to mechanical cooling requires one of the methods previously mentioned to maintain suitable condenser head pressure. Contact your local Daikin Applied representative for more information on this application.

Engineering Specifications

PART 1 - GENERAL

1.1 SUMMARY

A. Section includes design, performance criteria, refrigerants, controls, and installation requirements for water-cooled centrifugal chillers.

1.2 REFERENCES

A. Comply with the following codes and standards: AHRI 550/590, AHRI 575, NEC, ANSI/ASHRAE 15, OSHA as adopted by the State, ETL, ASME Section VIII

1.3 SUBMITTALS

A. Submittals shall include the following: Dimensioned plan and elevation view, including required clearances, and location of all field piping and electrical connections.

1. Summaries of all auxiliary utility requirements such as: electricity, water, air, etc. Summary shall indicate quality and quantity of each required utility.
2. Diagram of control system indicating points for field interface and field connection. Diagram shall fully depict field and factory wiring.
3. Manufacturer's certified performance data at full load plus IPLV or NPLV.
4. Installation and Operating Manuals.

1.4 QUALITY ASSURANCE

A. Regulatory Requirements: Comply with the codes and standards in Section 1.2.

A. Chiller manufacturer plant shall be ISO 9001 and ISO 14001 Certified.

A. The chiller shall be factory tested at the manufacturer's plant prior to shipment on an AHRI approved test stand.

1.5 DELIVERY AND HANDLING

A. Chillers shall be delivered to the job site completely assembled and charged with refrigerant R-515B and be shipped with a weather resistant cover. A wooden skid to aid in moving the unit and a tight fitting plastic covering the entire unit to protect from dirt/grime during transit/storage shall be provided as standard. The unit shall be delivered to the job site completely assembled and charged with refrigerant and ready for field knockdown. Contractor shall leak test, recover refrigerant, evacuate, and charge with refrigerant after reassembly.

-- OR --

A. [For Type B Knockdowns] The evaporator, condenser, compressor, suction and discharge piping, VFD power panel and touch screen shall be removed and shipped separately. All wiring and piping shall remain attached

where possible. The remaining loose parts shall be packaged in a separate crate. The unit is to be factory tested and shipped with an inert gas holding charge, evaporator insulated and a kit for compressor insulation. Contractor shall leak test, evacuate and charge with refrigerant after reassembly.

B. Comply with the manufacturer's instructions for rigging and transporting units. Leave protective covers in place until installation.

1.6 WARRANTY

A. The chiller manufacturer's warranty shall cover parts and labor costs for the repair or replacement of defects in material or workmanship for a period of one year from equipment startup or 18 months from shipment, whichever occurs first. The warranty will be delayed for 0 -OR- 2 -OR- 4 -OR- 6 -OR- 8 -OR- 10 -OR- 12 additional months. The entire unit warranty will be extended by 0 -OR- 1 -OR- 2 -OR- 3 -OR- 4 -OR- 9 years. The refrigerant warranty will be none -OR- included for first year -OR- 1 -OR- 2 -OR- 3 -OR- 4 -OR- 9 year extended. The compressor warranty will be extended in addition to the chosen entire unit warranty by 0 -OR- 1 -OR- 2 -OR- 3 -OR- 4 -OR- 9 years.

1.7 MAINTENANCE

A. Maintenance of the chillers in accordance with manufacturer's recommendations as published in the installation and maintenance manuals shall be the responsibility of the owner.

PART 2 - PRODUCTS

2.1 ACCEPTABLE MANUFACTURERS

A. Basis of Design - Daikin Applied Magnitude model WME-D, including the standard product features and all special features required per the plans and specifications.

B. Equal Products - Equipment manufactured by [ENTER MANUFACTURER NAME HERE] may be acceptable as an equal. Naming these products as equal does not imply that their standard construction or configuration is acceptable or meets the specifications. Equipment proposed "as equal" must meet the specifications including all architectural, mechanical, electrical, and structural details, all scheduled performance and the job design, plans and specifications.

2.2 UNIT DESCRIPTION

A. Provide and install as shown on the plans a factory assembled, charged, and tested water-cooled packaged centrifugal chiller. Chillers shall have no more than one oil-free, magnetic bearing, semi-hermetic centrifugal compressor (no exceptions). The compressor shall have an integrated variable-frequency drive operating in concert with inlet guide vanes for optimized full and part load efficiency. On two-compressor units, the evaporator and

condenser refrigerant sides and the expansion valve shall be common and the chiller shall be capable of running on one compressor with the other compressor or any of its auxiliaries inoperable or removed.

2.3 DESIGN REQUIREMENTS

A. General: Provide a complete water-cooled, semi-hermetic oil-free centrifugal compressor water chiller as specified herein. The unit shall be provided according to standards indicated in Section 1.2. In general, unit shall consist of one magnetic bearing, completely oil-free centrifugal compressor, refrigerant, condenser, evaporator, refrigerant economizer, and control systems including integrated variable frequency drive, operating controls and equipment protection controls. Chillers shall be charged with R-515B refrigerant.

B. If any portion of the chiller system is below atmospheric pressure during either operation or shut down, the manufacturer shall include, at no charge:

1. A complete purge system capable of removing non-condensables and moisture during operation and shut-down.

C. Performance: Refer to chiller performance rating.

D. Acoustics: Sound pressure for the unit shall not exceed the following specified levels. Provide the necessary acoustic treatment to chiller as required. Sound data shall be measured in dB according to AHRI Standard 575 and shall include overall dBA. Data shall be the highest levels recorded at all load points.

Octave Band								Overall dBA
63	125	250	500	1000	2000	4000	8000	

E. The unit shall be LEED certified and ASHRAE 90.1 compliant

2.4 CHILLER COMPONENTS

A. Compressors:

1. The unit shall utilize one magnetic bearing, oil-free, semi-hermetic centrifugal compressor. The compressor drive train shall be capable of coming to a controlled, safe stop in the event of a power failure.
2. The motor shall be of the semi-hermetic type, of sufficient size to efficiently fulfill compressor horsepower requirements. It shall be refrigerant-cooled with internal thermal sensing devices in the stator windings. The motor shall be designed for variable frequency drive operation.
 - a. If the compressor design requires a shaft seal to contain the refrigerant, the manufacturer shall supply a 20 year parts and labor warranty on the shaft seal and a lifetime refrigerant replacement warranty if a seal failure leads to refrigerant loss, or the chiller manufacturer shall assume all costs to

supply and install a self contained air conditioning system in the mechanical space sized to handle the maximum heat output of the open drive motor. The energy required to operate this air conditioning system shall be added to the chiller power at all rating points for energy evaluation purposes.

b. If the compressor/motor uses any form of antifriction bearing (roller, ball, etc), the chiller manufacturer shall provide the following at no additional charge: A 20-year bearing warranty and all preventative maintenance as specified by the manufacturer’s published maintenance instructions.

At start up, a three-axis vibration analysis and written report to establish bearing condition baseline.

An annual three-axis vibration analysis and written report indicating bearing condition.

3. The chiller shall be equipped with an air-cooled, unit mounted Variable Frequency Drive (VFD) to automatically regulate compressor speed in response to cooling load and the compressor pressure lift requirement. Liquid cooling is unacceptable. If a condenser water-cooled VFD is supplied, the manufacturer shall supply factory installed dual water filters with a bypass valve and pressure differential switch factory wired to the chiller control panel to indicate that a filter has clogged and requires service. The pressure differential switch shall also provide a separate dry contact which can be connected to the BAS system as a means of notifying operating personnel of the need to service the filters. If the condenser cooling circuit includes an intermediate heat exchanger, it must be of the brush cleanable shell and tube style. Brazed plate heat exchangers which cannot be field cleaned are not acceptable. Movable inlet guide vanes and variable compressor speed shall provide unloading. The chiller controls shall coordinate compressor speed and guide vane position to optimize chiller efficiency.
4. [OPTIONAL] A factory-installed, unit-mounted passive harmonic filter guarantees compliance with the IEEE 519 ratio-based maximum total demand distortion (TDD) when $I_{SC}/I_L > 20$.

B. Evaporator and Condenser:

1. The evaporator and condenser shall be separate vessels of the shell-and-tube type, designed, constructed, tested and stamped according to the requirements of the ASME Code, Section VIII. The tubes shall be individually replaceable and secured to the intermediate supports without rolling. The evaporator shall be flooded type with [0.025 in.] –OR– [0.028 in.] –OR– [0.035 in.] wall [copper] –OR– [90/10 CuNi] tubes rolled into tubesheets coated with [carbon steel] –OR– [monel clad] –OR– [stainless steel clad] –OR– [titanium clad steel] for corrosion protection. The water side vessel construction shall be designed for a minimum of [150 psig] –OR– [250 psig] –OR– [300 psig]. The dished heads/marine water boxes shall be coated for corrosion protection with [carbon steel] –OR– [Devcon]. Water connections shall be grooved

- suitable for [grooved couplings] –OR– [ANSI raised face flanged connections]. The evaporator shall have [dished heads with valved drain and vent connections] –OR– [shall be equipped with marine water boxes with removable covers and vent and drain connections to be removed without disconnecting the water piping from the chiller]. The evaporator shall have [right-hand] –OR– [left-hand] connections when looking at the unit control panel [OPTIONAL] Water box heads shall be hinged on both ends to aid in heat exchanger maintenance.
2. The condenser shall have [0.025 in.] –OR– [0.028 in.] –OR– [0.035 in.] wall [copper] –OR– [90/10 CuNi] –OR– [stainless steel] –OR– [titanium] tubes rolled into tubesheets coated with [carbon steel] –OR– [monel clad] –OR– [stainless steel clad] –OR– [titanium clad steel] for corrosion protection. The water side vessel construction shall be designed for a minimum of [150 psig] –OR– [250 psig] –OR– [300 psig]. The dished heads/marine water boxes shall be coated for corrosion protection with [carbon steel] –OR– [Devcon]. Water connections shall be [grooved suitable for grooved couplings] –OR– [ANSI raised face flanged connections]. The condenser [shall have [dished heads with valved drain and vent connections] –OR– [shall be equipped with marine water boxes with removable covers and vent and drain connections to be removed without disconnecting the water piping from the chiller]. The condenser shall have [right-hand] –OR– [left-hand] connections when looking at the unit control panel [OPTIONAL] Water box heads shall be hinged on both ends to aid in heat exchanger maintenance.
 3. Provide sufficient isolation valves and condenser volume to hold the full unit refrigerant charge in the condenser during servicing or provide a separate pumpout system and storage tank sufficient to hold the charge of the largest unit being furnished.
 4. An electronic expansion valve shall control refrigerant flow to the evaporator. Fixed orifice devices or float controls with hot gas bypass are not acceptable because of inefficient control at low load conditions. The liquid line shall have moisture indicating sight glass.
 5. Pressure relief devices shall be provided that meet ASME Section VIII and ASHRAE 15 requirements. If spring-loaded pressure relief valves are provided, the condenser shall be supplied with dual relief valves and a transfer valve so one relief valve can be removed for testing or replacement without refrigerant removal. The evaporator shall be provided with single or multiple valves. The condenser shall be provided with dual relief valves equipped with a transfer valve so one relief valve can be removed for testing or replacement without loss of refrigerant or removal of refrigerant from the condenser.
 6. [OPTIONAL] The evaporator shall be insulated with [3/4 in.] OR [1.5 in.] thick CFC and HCFC-free closed-cell flexible elastomeric foam insulation material with 100% adhesive coverage. The insulation shall have an additional outer protective layer of 3mm thick PE embossed film to provide superior damage resistance. Insulation without the protective outer film shall not be acceptable. UV resistance level shall meet or exceed a rating of 'Good' in accordance with the UNI ISO 4892 - 2/94 testing method. The economizer shall be designed, constructed, tested, and stamped according to ASME Section VIII and shall be flash-tank style.
 7. [OPTIONAL] The evaporator water box shall be insulated with UL recognized [3/4 in.] OR [1 ½ in.] closed cell insulation. All joints and seams shall be carefully sealed to form a vapor barrier.
 8. Provide factory-mounted and wired, thermal dispersion water flow switches on each vessel to prevent unit operation with no or low water flow.
- C. Vibration Isolation
1. Provide neoprene waffle-type vibration isolators for each corner of the unit.
- D. Power Connections
1. Power connection shall be single point to a factory mounted disconnect switch OR shall be multipoint to each compressor power panel on two-compressor units.
- E. Chiller Control
1. The unit shall have a microprocessor-based control system consisting of a touch-screen operator interface and a unit controller.
 2. The touch-screen shall display the unit operating parameters, accept setpoint changes (multi-level password protected) and be capable of resetting faults and alarms. The following parameters shall be displayed on the home screen and also as trend curves on the trend screen:
 - a. Entering and leaving chilled and condenser water temperatures
 - b. Evaporator and condenser saturated refrigerant pressures
 - c. Percent of 100% speed (per compressor)
 - d. % of rated load amps for entire unit
 3. In addition to the trended items above, all other important real-time operating parameters shall also be shown on the touch-screen. These items shall be displayed on a chiller graphic showing each component. At a minimum, the following critical areas must be monitored:
 - a. Compressor actual speed, maximum speed, percent speed
 - b. Evaporator water in and out temperatures, refrigerant pressure and temperature
 - c. Condenser water in and out temperatures, refrigerant pressure and temperature
 - d. Liquid line temperature
 - e. Chilled water setpoint

- f. Compressor and unit state and input and output digital and analog values
4. A fault history shall be displayed using an easy to decipher, color coded set of messages that are date and time stamped. The alarm history shall be downloadable from the unit's USB port. An operating and maintenance manual specific for the unit shall be viewable on the screen and downloadable.
 5. All setpoints shall be viewable and changeable (multi-level password protected) on the touch screen and include setpoint description and range of set values.
 6. Automatic corrective action to reduce unnecessary cycling shall be accomplished through preemptive control of low evaporator or high discharge pressure conditions to keep the unit operating through abnormal transient conditions.
 7. The chiller shall be capable of automatic control of: evaporator and condenser pumps (primary and standby), up to 3 stages of cooling tower fan cycling control and a tower modulating bypass valve or cooling tower fan variable frequency drive.
 8. Optionally, the factory mounted controller(s) shall support operation on a BACnet® or Modbus® network via one of the data link / physical layers listed below as specified by the successful Building Automation System (BAS) supplier.
 - a. Modbus®
 - b. BACnet® MS/TP master (Clause 9)
 - c. BACnet® IP, (Annex J)
 9. The information communicated between the BAS and the factory mounted unit controllers shall include the reading and writing of data to allow unit monitoring, control and alarm notification as specified in the unit sequence of operation and the unit points list.
 10. All communication from the chiller unit controller as specified in the points list shall be via standard BACnet® objects. Proprietary BACnet® objects shall not be allowed. BACnet® communications shall conform to the BACnet® protocol (ANSI/ASHRAE135-2001). A BACnet® Protocol Implementation Conformance Statement (PICS) shall be provided along with the unit submittal.
 11. The chiller shall be able to maintain operation during a momentary power loss event. The chiller shall be able to ride through this momentary power loss event without shutting down. Chillers not able to maintain operation during momentary power loss events shall include a properly sized thermal storage tank to maintain temperature stability in the system.
 12. The chiller shall be equipped with the capability to restart and reach full load quickly in the event of a power interruption. The compressor shall be capable of restarting quickly with a UPS after power is restored and shall reach 80% load quickly. Chillers not able to restart or load within this time frame shall include a properly sized thermal storage

tank to maintain temperature stability in the system.

2.5. OPTIONAL ITEMS

- A. The following optional items shall be furnished:
1. Open OR closed export crate
 2. Pumpout unit, with or without storage vessel
 3. Refrigerant monitor
 4. Non-witness full and/or part load performance test (water only) performed by a factory engineer and include data to be compiled, certified, and transmitted to customer(s) in accordance with procedures and to the tolerances contained in AHRI Standard 550/590.

-- OR --

Witness full and/or part load performance test (water only) performed in the presence of the customer(s) under supervision of a factory engineer and include compilation of the test data onto an easy-to-read spreadsheet in accordance with procedures and to the tolerances contained in AHRI Standard 550/590.

PART 3 - EXECUTION

3.1 INSTALLATION

- A. Installing contractor to:
1. Install per manufacturer's requirements, shop drawings, and contract documents.
 2. Adjust chiller alignment on foundations, or subbases as called for on drawings.
 3. Arrange piping to allow for dismantling to permit head removal and tube cleaning.
 4. Coordinate electrical installation with electrical contractor.
 5. Coordinate controls with control contractor.
 6. Provide all material required for a fully operational and functional chiller.

3.2 START-UP

- A. Factory Start-Up Services: Provide for as long a time as is necessary to ensure proper operation of the unit, but in no case for less than two full working days. During the period of start-up, the start-up technician shall instruct the owner's representative in proper care and operation of the unit.

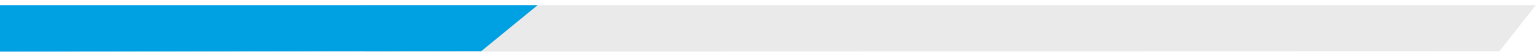

COMPLETE HVAC SYSTEM SOLUTIONS

SELF-CONTAINED | ROOFTOPS | COILS | CONDENSING UNITS
AIR HANDLERS | WATER-COOLED CHILLERS | AIR-COOLED CHILLERS
MODULAR CENTRAL PLANTS | SITELINE BUILDING CONTROLS
UNIT HEATERS | FAN COILS | AIR PURIFIERS | WATER SOURCE HEAT PUMPS
VARIABLE AIR VOLUME UNITS | UNIT VENTILATORS



13600 INDUSTRIAL PARK BLVD. | MINNEAPOLIS, MN 55441
1-800-432-1342 | 763-553-5330

LEARN MORE AT
DAIKINAPPLIED.COM