



SMARTSOURCE[®]

CONSOLE WATER SOURCE HEAT PUMP

Model WSRC
1/2 to 1-1/2 Tons
R-32 Refrigerant



Introduction	3	Electrical Data	25
SmartSource® Console Water Source Heat Pumps . . .	3	Typical Wiring Diagrams	26
Model Nomenclature	4	Physical Data Table	33
Components and Technology	7	Dimensional Drawings	34
Component and Option Details	8	System Considerations	42
Optional Factory Installed Features	8	Unit Location	43
Controls	9	Piping	43
Accessories	13	Condensate drain	43
AHRI Performance Data	17	System Applications	44
Capacity Data	18	Selection Procedure	46
Fan Performance	23	Engineering Specifications	47
Capacity Correction Factors	24		



Hazard Identification

DANGER
Danger indicates a hazardous situation, which will result in death or serious injury if not avoided.

WARNING
Warning indicates a potentially hazardous situations, which can result in property damage, personal injury, or death if not avoided.

CAUTION
Caution indicates a potentially hazardous situations, which can result in minor injury or equipment damage if not avoided.

NOTICE
Notice indicates practices not related to physical injury.

NOTE: Indicates important details or clarifying statements for information presented.

©2026 Daikin Applied, Minneapolis, MN. All rights reserved throughout the world. This document contains the most current product information as of this printing. Daikin Applied Americas Inc. has the right to change the information, design, and construction of the product represented within the document without prior notice. For the most up-to-date product information, please go to www.DaikinApplied.com.

™ MicroTech, SmartSource, and Daikin Applied are trademarks or registered trademarks of Daikin Applied Americas Inc. The following are trademarks or registered trademarks of their respective companies: BACnet from American Society of Heating, Refrigerating and Air-Conditioning Engineers, Inc.; Echelon, LonWorks, LonMark, and LonTalk from Echelon Corporation; Modbus from Schneider Electric; and Windows from Microsoft Corporation.

Introduction

SmartSource® Console Water Source Heat Pumps

More than 30 years ago, our team designed the first complete line of water source heat pumps for high efficiency, individually-zoned comfort control in offices, schools, assisted living facilities, manufacturing facilities and other commercial buildings. Daikin Applied's reputation for outstanding reliability and quiet operation has been reinforced in thousands of successful installations.

SmartSource water source heat pumps incorporate the best of our past and the best of what's new. Using feedback from building owners, consulting engineers, contractors and service engineers, we designed SmartSource products to give you maximum flexibility to design, install, operate and maintain the ideal water source heat pump system for your building project. And we incorporated low GWP R-32 refrigerant, which—along with high Energy Efficiency Ratios (EER's)—helps preserve our environment and precious energy resources.

SmartSource Water Source Heat Pump Benefits

High efficiency that minimizes environmental impact and lowers operating costs

- Units exceed ASHRAE Standard 90.1 minimum requirements
- Standard range or geothermal application flexibility

Engineered for flexibility and performance

- Two cabinet sizes, each with Daikin Applied's subtle aesthetic and small footprint design, make it easy to meet the space requirements of your new construction or replacement application.
- MicroTech® unit controller allows easy, low cost integration.

Improved efficiency

- Factory-installed, unit-mounted thermostats save time and money versus installing wall-mounted thermostats.
- Wide range of factory-installed options, including electric heat, motorized valves and thermostat options help you meet more specific application requirements with minimum design or installation time and expense.

Easy, low-cost maintenance

- Easy access to the unit compressor (end panel), fan section and coil (front panel) and unit controls (left or right end panel).
- An easily removable blower motor allows the tangential fan wheel to remain in the housing during motor replacement.
- A hinged control box allows easy access to the piping compartment.

Quiet operation

- Tangential fan wheel allows the fan motor to operate at lower speed for quieter operation.
- High efficiency rotary compressor mounted on a mass plate system reduces noise due to vibration.

Superior indoor air quality (IAQ)

- Removable, non-corrosive and double-sloped polymer drain pan promotes positive condensate drainage.
- Optional closed-cell insulation prevents insulation fibers from entering the air stream.

Model Nomenclature

1	2-4	5	6-8	9	10	11	12	13	14-15	16-17	18	19	20	21-22	23	24-26	27-29	30-32	33	34	35-37	38	39	40	41	42	43	44
W	SRC	1	007	M	E	H	B	T	01	S2	A	C	Y	YY	L	UPY	YYY	YYY	A	Y	50V	Y	S	Y	D	1	L	1

Category	Code Option	Code	=	Description
Product Category	1	W	=	Water Source Heat Pump
Model Type	2-4	SRC	=	SmartSource Console
Design Series (Vintage)	5	1	=	Design Series 1
Nominal Capacity	6-8	007	=	7,000 Btu/h Nominal Cooling
		009	=	9,000 Btu/h Nominal Cooling
		012	=	12,000 Btu/h Nominal Cooling
		015	=	15,000 Btu/h Nominal Cooling
		018	=	18,000 Btu/h Nominal Cooling
Controls	9	M	=	MicroTech Unit Controller
		B	=	MicroTech Unit Controller + BACnet
Voltage	10	A	=	115/60/1 (Sizes 007-012)
		E	=	208-230/60/1
		J	=	265/60/1
Cabinet Height	11	H	=	High Sill (25")
		L	=	Low Sill (22.5")
Return Air/Corrosion Protection	12	B	=	Bottom Return Air (High Sill)
		F	=	Front Return Air (Low Sill)
		N	=	Bottom Return Air with Corrosion Protection (High Sill)
		M	=	Front Return Air with Corrosion Protection (Low Sill)
Discharge Air	13	T	=	Top Discharge
Fan Motor Options	14-15	01	=	PSC
Cabinet Type	16	A	=	Flat Top with 12" Extended End Pocket (High Sill)
		B	=	Slope Top with 12" Extended End Pocket (High Sill)
		F	=	Flat Top
		S	=	Slope Top
Discharge Grille	17	C	=	Chassis Only (N/A with 12" Extended End Pocket Option)
		2	=	Standard Stamped Louver - Painted Steel
		3	=	Multi-Directional Grille - Plastic (N/A with Electric Heat Option)
Construction Type	18	A	=	1/2" Fiberglass Insulation
		E	=	3/8" Closed Cell Foam (IAQ)
Water to Refrigerant Heat Exchanger Construction	19	C	=	Copper Inner Tube - Steel Outer Tube
		S	=	Cupronickel Inner Tube - Steel Outer Tube
		G	=	Copper Inner Tube - Steel Outer Tube (Geothermal)
		J	=	Cupronickel Inner Tube - Steel Outer Tube (Geothermal)
Heating Options	20	2	=	2.5 kW Electric Heat (Sizes 007-012, with 208-230/60/1 or 265/60/1 Electrical)
		3	=	3.5 kW Electric Heat (Sizes 015-018)
		Y	=	None
Future Use	21-22	YY	=	None
Piping Hand	23	L	=	Left
		R	=	Right

1	2-4	5	6-8	9	10	11	12	13	14-15	16-17	18	19	20	21-22	23	24-26	27-29	30-32	33	34	35-37	38	39	40	41	42	43	44
W	SRC	1	007	M	E	H	B	T	01	S2	A	C	Y	YY	L	UPY	YYY	YYY	A	Y	50V	Y	S	Y	D	1	L	1

Category	Code Option	Code	=	Description
Thermostat Control	24	R	=	Wireless
		S	=	Remote Wall Mounted Space Sensor with NSB Override
		U	=	Unit Mounted Thermostat
		W	=	Remote Wall Mounted Thermostat with Unit Mounted Fan Speed Switch
Thermostat Programmability	25	N	=	Non-Programmable
		P	=	Programmable
		Y	=	None
Thermostat Option	26	L	=	Low Limit Control
		M	=	Low Limit Control and Unit Mounted NSB Override Switch
		P	=	NSB Override Switch
		Y	=	None
Specials	27-29	YYY	=	None
		XXX	=	Special
Options	30-32	YYY	=	None
		B02	=	2" Rear Extension
		B04	=	4" Rear Extension
		B06	=	6" Rear Extension
				High Sill Only
Refrigerant	33	A	=	R-32
Power Connection	34	Y	=	None
		C	=	Unit Mounted 20A Plug and Cord
		D	=	Unit Mounted 20A Plug and Cord with Fused Disconnect Switch (High Sill Only)
		E	=	Unit Mounted 20A Plug and Cord with Non-Fused Disconnect Switch (High Sill Only)
				N/A with Electric Heat Option
Cabinet Electrical	35-37	50V	=	50VA
		75V	=	75VA
Water Flow Control	38	H	=	2-Way Motorized Isolation Valve, High Close-Off Pressure N.C. (Normally Closed)
		P	=	2-Way Motorized Isolation Valve, High Close-Off Pressure N.C. (Normally Closed); Supply, Return, and Bypass Hand Valves; Air Vent; Auto Flow Valve
		R	=	Supply, Return and Bypass Valves; Air Vent
		W	=	2-Way Motorized Isolation Valve, High Close-Off Pressure N.C. (Normally Closed); Supply, Return, and Bypass Hand Valves; Air Vent
		Y	=	None

1	2-4	5	6-8	9	10	11	12	13	14-15	16-17	18	19	20	21-22	23	24-26	27-29	30-32	33	34	35-37	38	39	40	41	42	43	44
W	SRC	1	007	M	E	H	B	T	01	S2	A	C	Y	YY	L	UPY	YYY	YYY	A	Y	50V	Y	S	Y	D	1	L	1

Category	Code Option	Code	=	Description
Color	39	S	=	Antique Ivory Cabinet with Oxford Brown Grille and Subbase
		T	=	Antique Ivory Cabinet and Grille with Oxford Brown Subbase
		B	=	Antique Ivory Cabinet, Grille and Subbase
		D	=	Cupola White Cabinet with Oxford Brown Grille and Subbase
		P	=	Cupola White Cabinet and Grille with Oxford Brown Subbase
		E	=	Cupola White Cabinet, Grille and Subbase
		G	=	Off White Cabinet with Oxford Brown Grille and Subbase
		K	=	Putty Beige Cabinet with Oxford Brown Grille and Subbase
		V	=	Soft Grey Cabinet with Oxford Brown Grille and Subbase
		F	=	Off White Cabinet and Grille with Oxford Brown Subbase
		H	=	Off White Cabinet, Grille and Subbase
		R	=	Putty Beige Cabinet and Grille with Oxford Brown Subbase
		L	=	Putty Beige Cabinet, Grille and Subbase
		J	=	Soft Grey Cabinet and Grille with Oxford Brown Subbase
		N	=	Soft Grey Cabinet, Grille and Subbase
Y	=	None (Chassis Only Option)		
Outside Air	40	Y	=	None
Agency Type	41	D	=	ETL, CETL, AHRI
Packaging	42	1	=	Standard
Extended Warranty	43	L	=	First Year Labor Allowance
		M	=	1 Year Extended Compressor Only Parts Warranty with 1st Year Labor Allowance
		N	=	1 Year Extended Refrigerant Circuit Parts Warranty with 1st Year Labor Allowance
		S	=	1 Year Extended Complete Unit Parts Warranty with 1st Year Labor Allowance
		F	=	4 Year Extended Compressor Only Parts Warranty with 1st Year Labor Allowance
		H	=	4 Year Extended Refrigerant Circuit Parts Warranty with 1st Year Labor Allowance
		J	=	4 Year Extended Complete Unit Parts Warranty with 1st Year Labor Allowance
		T	=	4 Year Extended Complete Unit Parts Warranty with 5 Year Labor Allowance
Product Style	44	1	=	Style 1

Available with Stamped Louver or Multi-Directional Grille Options

Available with Stamped Louver Grille Option Only

Components and Technology



Paint Color Options					
Cupola White	Off White	Putty Beige	Soft Gray	Antique Ivory	Oxford Brown (Discharge Grille & Subbase)

No.	Component	Description
1	Cabinets	The unit is designed to provide flexibility with slope top or flat top configurations and directional grille options. Removable top, front, and end panels offer service accessibility.
2	Compressor	The compressor offers increased energy savings using a high efficiency rotary design.
3	Fan system	The unit has a high efficiency and quiet multi-speed tangential fan system.
4	MicroTech unit controller	The MicroTech unit controller includes streamlined network controls using BACnet® communication modules and an I/O expansion module for electric heat and multiple fan speeds.
5	LED Status View Port	LED status lights display fault conditions to provide easy troubleshooting and diagnosis.
6	Filter	The 1/2" standard disposable filter is easily accessible and serviceable.
7	Hinged control box	The hinged control box increases service access to the plumbing end compartment for fast installation and maintenance.
8	2-way motorized valve packages (optional)	Factory-installed or field-installed valve packages are available for variable pumping applications which can help to reduce operating costs with two-way isolation valves.
9	Double-sloped drain pan	The drain pan is made of non-corrosive polymer and designed to be easily removable and cleanable.
10	Wireless thermostat (optional) with Remote control node (RCN)	An optional wireless thermostat offers precise temperature control without installation and wiring expenses. It can be factory or field-installed on all thermostat controlled units. The remote control node (RCN) provides easy integration with unit and temperature controls.
11	Multi-directional grilles (optional)	The direction of discharge air can be controlled using rotatable grilles.
12	High sill extended end pocket (optional)	The extended end pocket option for high sill units increases service access by 11" for piping or a field-installed pump.
Options Not Shown		Description
Outside air dampers		Increased ventilation air control - motorized or manual operation
3.5", 7" High sub base		Increases piping arrangement flexibility
2", 4", 6" Cabinet rear extension		Extends space behind unit for piping (high sill units only)

Component and Option Details

Configuration

Console water source heat pumps are available in five cooling capacity sizes, from ½ through 1½ tons. Each is available in four different configurations.

Flat top units meet the traditional requirements for a rugged unit. Slope top units offer a more modern look. The high silhouette unit is 25" (635 mm) high and the low silhouette unit is only 22½" (572 mm) high. The overall unit dimensions are very compact; unit sizes 007 through 012 are 46" (1168 mm) long and sizes 015 through 018 are 54" (1372 mm) long. All units are 10¾" (273 mm) deep for minimum floor space and a consistent "look" for all unit sizes.

All units incorporate a slide-out chassis concept which allows it to be installed easily or removed and replaced quickly when service is required to minimize downtime for the space the unit serves. The cabinet is made up of individual panels, each of which can be easily removed to expose the chassis for field hook-up of water and electrical connections. The chassis easily slides off the subbase for service or changeout.

Cabinet

All cabinets are painted with optional Antique Ivory, Cupola White, Off White, Putty Beige, or Soft Gray baked enamel finish for an aesthetically pleasing appearance. The discharge grilles and subbase can be Oxford Brown or match the cabinetry on flat top or slope top units.

The shallow 22 degree slope top cabinet is constructed of 18-gauge steel. The top and side corners and grille are constructed of tough, impact-resistant ABS polycarbonate. The grille extends to the front and sides for a smooth look as well as providing a curtain stop in back. The discharge grilles can be rotated to direct the air in an 11 degree angle from the vertical and can be reversed for a 33 degree discharge angle. The control door has a finger slot and simply lifts up for access to the thermostat. Overall, the slope top unit allows minimal airflow interference from curtains and objects resting on the cabinet, while at the same time providing a rugged, aesthetically pleasing look.

The flat top cabinet is constructed of 18-gauge steel with grille options that meet basic needs with its rugged construction and its 11 degree discharge angle.

Chassis

The chassis houses the fan section, refrigerant circuit and controls. The air enters through the bottom of the chassis, through the subbase or through the front panel in low sill units.

The refrigeration system includes a rotary compressor, reversing valve, coaxial heat exchanger, TXV, air coil, high and low side access valves, and safety controls. Access to the compressor is through a removable end panel. The compressor is isolated from the unit with external vibration mounts, mass plate/ viscoelastic dampening material and the compartment is totally insulated to reduce sound. Safety controls include a low

suction line temperature sensor and refrigerant high pressure switches. The control box is hinged for easy access to all of the controls. The MicroTech unit controller offers both standalone or communicating (BACnet) control options.

Each uses a printed circuit board for clean wiring and a low voltage control circuit with an optional 75 VA transformer. Main power is made to a chassis-mounted 2" x 4" (51 mm x 102 mm) junction box.

The fan section employs a tangential system fan and efficient, two-speed PSC motor for selectable airflow and/or noise level. Access to the fan wheel is made through the top panel. The motor is secured to the chassis with three screws for easy service.

Water piping connections are ⅝" (16 mm) O.D. copper tubing (sweat connection stubs) and terminate away from the side of the chassis in the piping compartment for easy access. Unique left- and right-hand piping (includes condensate and electrical) locations are available. The ¾" (19 mm) I.D. flexible clear vinyl condensate drain tube is internally trapped and extends 14" (356 mm) into the piping compartment for easy connection. Piping (electrical and condensate also) can enter through the back wall or through the floor within the subbase. The chassis allows for a piping compartment between the chassis and the cabinet.

Optional Factory Installed Features

Boilerless system electric heat eliminates the need for a boiler in the heat pump water loop. An electric heater is added to the discharge side of the fan scroll. If the entering water temperature falls to 55°F (13°C) the thermostat locks out compressor operation. On a call for heat, the electric heater is energized. When the entering water temperature raises, the unit will resume compressor operation on a call for heat. An emergency electric heat override plug allows for electric heat, if the compressor (mechanical system) heat should fail. Console units have a boilerless heat size option of 2.5 kW (sizes 007-012) or 3.5 kW (sizes 015-018). Not available on 115 volt units. Not CSA listed.

Extended End Pocket (High Sill Units)

Optional extended cabinet end pocket for high sill units, provides 11" (279 mm) of additional area inside the left or right end pocket for piping or a field-installed pump.

Multi-Directional Grilles

Selectable plastic Multi-Directional Grilles can rotate 90, 180, or 270 degrees for added control of discharge air direction.

Cabinet Rear Extension (High Sill Units)

The optional, factory-installed rear extension (high sill units only) provides extended space between the wall and unit for piping. Extension size options of 2" (51 mm), 4" (102 mm), or 6" (152 mm) available.

Controls

MicroTech Controller with an Optional BACnet Communication Module



For installation and operation information on MicroTech unit controller and other ancillary components, see:

- OM 1364 - MT2300 Unit Controller with MT2310 I/O Expansion Board MicroTech Controller
- IM 956 - Temperature Sensors for Units with MicroTechIII or MT2300 Unit Controller and LonWorks® or BACnet Communication Module
- IM 1363 - MicroTech MT2300 Water Source Heat Pump Unit Controller BACnet MS/TP Communication Module
- ED 19129 - MicroTech MT2300 Water Source Heat Pump Unit Controller BACnet Protocol Information

Daikin Applied water source heat pumps are available with an optional BACnet MS/TP communication module that is designed to communicate over a BACnet MS/TP communications network to a building automation system (BAS). It can be factory or field-installed.

The unit controller is programmed and tested with all the logic required to monitor and control the unit. An optional wall sensor may be used with the communication module to provide limited local control of the water source heat pump. The unit controller monitors water and air temperatures and passes information to the communication module. The module communicates with the BAS, to provide network control of the water source heat pump.

The module makes operational data and commands available on a communications network using BACnet objects and properties:

- The network cable is a shielded twisted-pair cable
- Network communications run up to 76.8 kbps
- DIP switches on the controller enable the MS/TP MAC address to be set in the range 0-127
- Four green status LEDs on the communication module indicate communication activity on the MS/TP communication network and with the unit controller

MicroTech unit controller with BACnet MS/TP communication module orchestrates the following unit operations:

- Enable heating and cooling to maintain setpoint based on a room sensor
- Enable fan and compressor operation
- Monitors all equipment protection controls
- Monitors room and discharge air temperatures
- Monitors leaving water temperature
- Relays status of all vital unit functions

The MicroTech unit controller with an optional communication module includes:

- Return Air Temperature sensor (RAT) (field-installed)
- Discharge Air Temperature sensor (DAT) (field-installed)
- Leaving Water Temperature sensor (LWT)

NOTICE

Refer to IM 956 for details to install RAT & DAT sensors.

The communication module provides access to setpoints for operational control.

Available wall sensors include:

- Room sensor with LED status and tenant override button
- Room sensor with LED status, tenant override button, and $\pm 5^{\circ}\text{F}$ setpoint adjustment
- Room sensor with LED status, tenant override button, 55° to 95°F (13° to 35°C) setpoint adjustment

Wall Mounted Thermostats and Remote Indoor Sensor

Table 1: Thermostat Selections









Wall Mounted Thermostats & Remote Sensor for Use with All SmartSource WSHP Units		Thermostats				Remote Sensor
		Non-Programmable	Programmable (7 Day or 5+1+1)		7 Day Programmable	Remote Indoor Thermostat Sensor
		2H/2C	2H/2C	2H/3C Humidity Control	2H/3C Humidity Control WIFI	
						
Daikin Applied Part Number		910411879	910411880	910417943	910417944	910420874
Feature						
LCD Display	Room Temperature & Setpoint	•	•	•	•	Allows Remote Temperature Sensing
	Room Humidity %			•	•	
Glow in the Dark Display Light		•	•	•	•	
Operating Modes	System	Heat-Off-Cool-Auto	Heat-Off-Cool-Auto	Heat-Off-Cool-Auto	Heat-Off-Cool-Auto	Use up to 16 Sensors for Temperature Averaging
	Fan	On-Auto	On-Auto	On-Auto-IAQ	On-Auto-IAQ	
Changeover	Manual	•	•	•	•	
	Auto	•	•	•	•	
Temperature Control Range		44°F to 90°F (7°C to 32°C)	44°F to 90°F (7°C to 32°C)	44°F to 90°F (7°C to 32°C)	44°F to 90°F (7°C to 32°C)	
Adjustable Setpoint Limits		•	•	•	•	
Keypad Lockout				•	•	
Filter Change Reminder			•	•	•	
Programmable Fan		•	•	•	•	
Power Type	Battery	2 AA Alkaline Batteries				
	Hardwire (Common Wire)	18 to 30 VAC	18 to 30 VAC	18 to 30 VAC	18 to 30 VAC	
Permanent Memory Retention		•	•	•	•	
Remote Indoor Sensor Capable (Requires Daikin Applied P/N 910420874)			•	•	•	
Terminals		Rh, RC, G, Y, Y2, C, O, B, W/E, W2	Rh, RC, C, Y, Y2, W/E, W2, G, B, O, S1, S2	Rh, RC, C, Y, Y2, W/E, W2, G, B, O, S1, S2, H, D	Rh, RC, C, Y, Y2, W/E, W2, G, B, O, S1, S2, H, D	
Application						
Dehumidification	Smart Dehumidification			•	•	
	Simplified	•	•	•	•	
	Humidistat Controlled			•	•	
Electric Heat	Boilerless	•	•	•	•	
	Supplemental	•	•	•	•	
	Primary	•	•	•	•	
Waterside Economizer		•	•	•	•	
Hydronic Heat		•	•	•	•	

Table 2: Room Temperature Sensors

Room Sensors for Use with All SmartSource WSHP Units with a BACnet Communication Module		Room Temperature Sensors					
		Basic Room Sensor	Cool to Warm Adjust	Digitally Adjustable Display Sensor			
						Temperature Sensing, LED Status Indication, Override/Reset Button	Cool/Warm Temperature Sensing Adjustment, LED Status Indication, Override/Reset Button
Daikin Applied Part Number	910152149	910171464	910152147	910121754	Feature		
Setpoint Adjustment		None	Cool to Warm	Digitally Adjustable	Digitally Adjustable		
Display	Room Temperature & Setpoint			•	•		
	Room Humidity & Setpoint				•		
Stages	Heating	4	4	4	4		
	Cooling	3	3	3	3		
Operating Modes	System					Heat-Off-Cool-Auto Dehumidify	
	Fan					On-Auto	
	Occupancy			LCD Display of Occupied-Unoccupied Icon	LCD Display of Occupied-Unoccupied Icon		
Annunciation	Status LED	•	•	LCD Display of Unit Status	LCD Display of Unit Status		
	LCD Alarm Display			•	•		
Reset	Alarm	•	•	•	•		
	Setback Override	•	•	•	•		
Application							
Dehumidification	Smart Dehumidification					•	
Electric Heat	Boilerless	•	•	•	•		
	Supplemental	•	•	•	•		
	Primary	•	•	•	•		
Waterside Economizer		•	•	•	•		
Hydronic Heat		•	•	•	•		

Wireless Temperature Control

The wireless thermostat option is designed to provide precision temperature control without the installation labor and expense of wiring.

- Powered by AA batteries
- Mounts in any suitable location that will provide good temperature control.
- Large LCD display provides the user with current room temperature, set point temperature, time, program interval, and other system status information.

For detailed installation and operation information, refer to the manual provided with the thermostat.

Figure 1: Wireless Thermostat

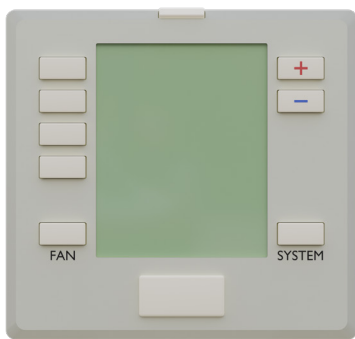

The second part of the wireless system is called a Remote Control Node or "RCN." An RCN interfaces with specific desired HVAC equipment, and communicates with its thermostat wirelessly. At the time of installation, the wireless thermostat is linked to the RCN. The thermostat and RCN that have been linked will not interfere with, or be affected by, any other thermostat or RCN in adjacent rooms, apartments, or neighboring homes.

Figure 2: Remote Control Node (RCN)



Multiple Unit Control Panel (MUCP)

Figure 3: Multiple Unit Control Panel and Board

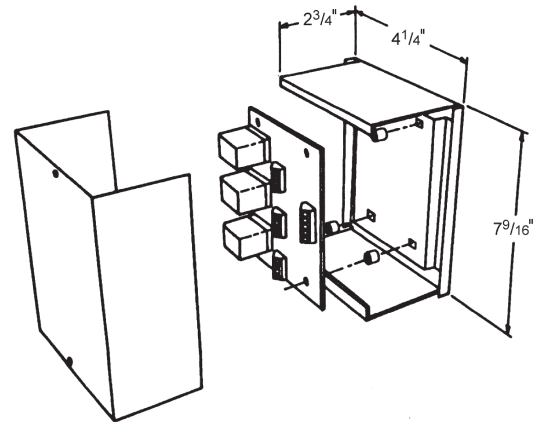

The Multiple Unit Control Panel (MUCP) is an accessory used when up to 3-units are controlled from a single thermostat. Console units must have the MUCP field-installed in a remote location, typically close to the units and convenient for service access.

A multiple unit control panel allows a single wall-mounted thermostat to control up to three units in a common space.

An auxiliary relay controls optional devices when the fan is operating. The relay has SPDT contacts.

NOTICE

The MUCP control board does not fit inside the console unit control box.

A maximum of 2 boards may be used together if up to 6-units must be connected and controlled from a single thermostat.

NOTICE

Multi-speed operation is only available with the optional unit-mounted fan speed switch.

Figure 4: Multiple Unit Control Panel Circuit Board



The multiple unit control board provides the components necessary to protect the MicroTech unit controller from electrical damage that may occur when using standard off-the-shelf relays.

This version of the board uses VAC relays and should not be used in combination with any other accessories or equipment that require VDC connections to the "G", "W1", or "Y1" terminals.

Accessories

Supply and Return Water Hoses

Hose kits with standard flexible supply and return hoses are recommended between the water source heat pump unit and building's hard piping system. This is to control possible noise and transmission of vibration from the unit in the space.

Standard supply and return fire-rated hoses have an inner tube of (EPTF) white santoprene with a braided covering of stainless steel. The supply and return hoses have a swivel fitting at one end to facilitate removal of the unit for replacement or service. Hose fittings are of plated steel with the fixed end MNPT and the swivel end fitting of 5/8" (16 mm) sweat brass. The maximum operating temperature is -4 to 212°F (-20 to 100°C).

The kit available for console units (Hose Kit # 3) includes a set of two hoses with a 1/2" (13 mm) connection size, in lengths of 9" (229 mm), 12" (305 mm), 18" (457 mm), and 24" (610 mm). The supply and return hoses have one fixed MNPT end and a female JIC swivel with 5/8" (16 mm) ID female sweat adapter. Contact your Daikin Applied representative for more detailed hose kit features.

Figure 5: Fire Rated Supply or Return Hoses



Table 3: Hose Specifications

Hose Type	Nominal Length	Maximum Recommended Working Pressure	Minimum Burst Pressure @ 70° to 90°	Minimum Bend Radius
1/2" MNPT Supply & Return	9"	400 psig	1600 psig	2½"
	12"	400 psig	1600 psig	2½"
	18"	400 psig	1600 psig	2½"
	24"	400 psig	1600 psig	2½"

Figure 6: Hose Detail

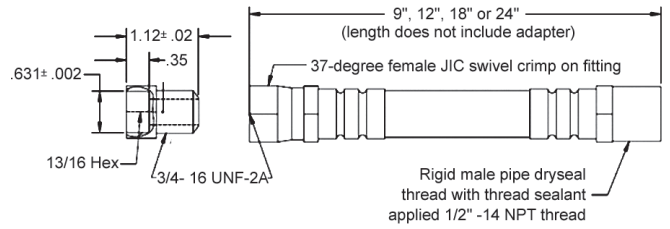

Combination Balancing and Shutoff Valves

Constructed of brass and rated at 400 psig (2758 kPa) maximum working pressure. Valves have a built-in adjustable memory stop to eliminate rebalancing. Valves have FPT connections on both ends for connection to the water hose and to the field piping.

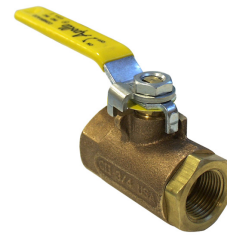

2-Way Motorized Valve

Used for variable pumping applications, the valve is wired in the compressor circuit and piped in the return water line from the unit.



A motorized valve relay and control valve assembly includes a relay, valve, and wire harness. The valve opens when the compressor is turned on and closes when the compressor is off. The valve is rated for 300 psig (2068 kPa). Motorized valves can be ordered as a field-installed accessory.

Piping Package (Options)

Piping packages can be ordered as a factory-installed option. Supply and return 5/8" O.D. copper tubing, (sweat connection stubs) are standard on unit piping and optional piping packages.

Figure 7: Typical Piping Package Configurations (Left-Hand Unit Piping Connections Shown)

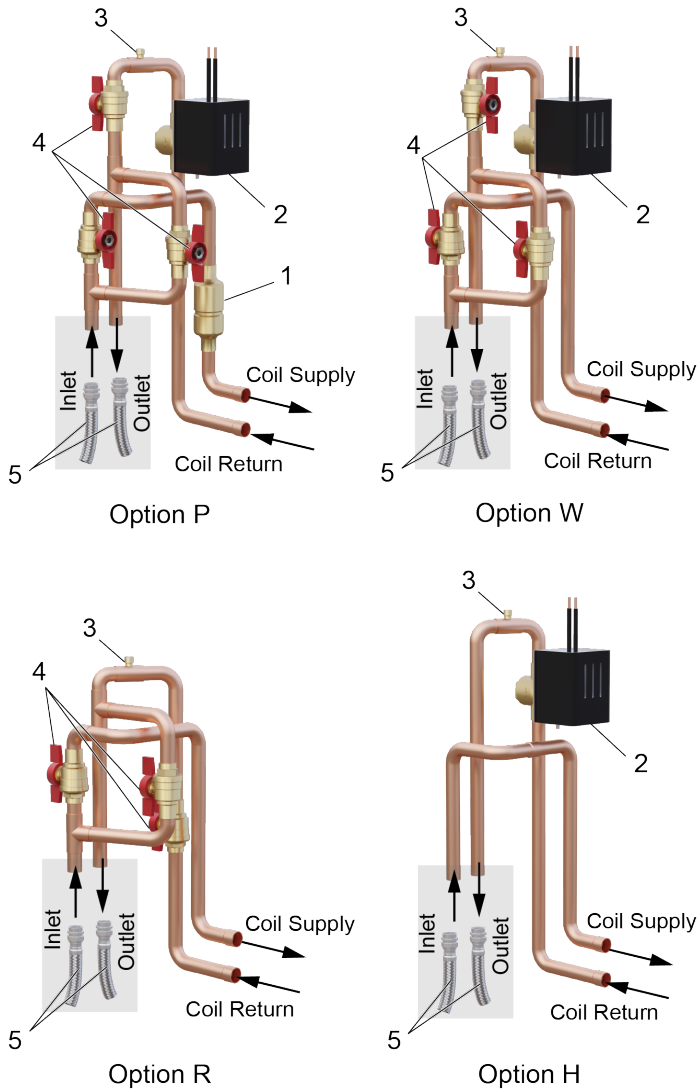

Piping Packages Dimensions – Left Hand

Figure 8: Left-Hand, Motorized Valve with Flow Control and Manual Valves

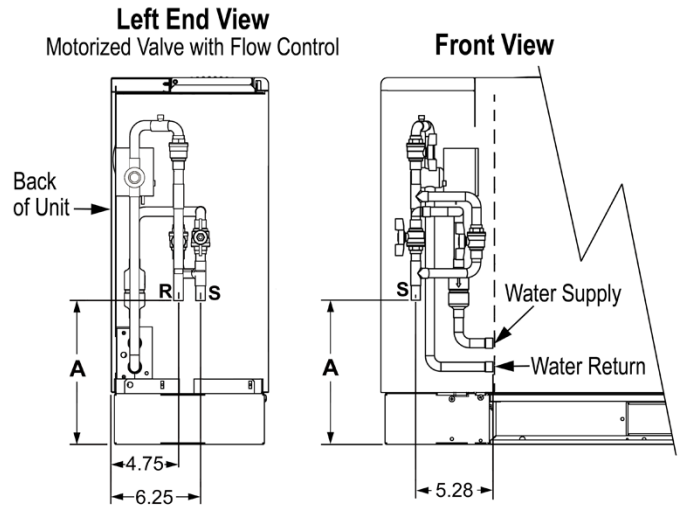
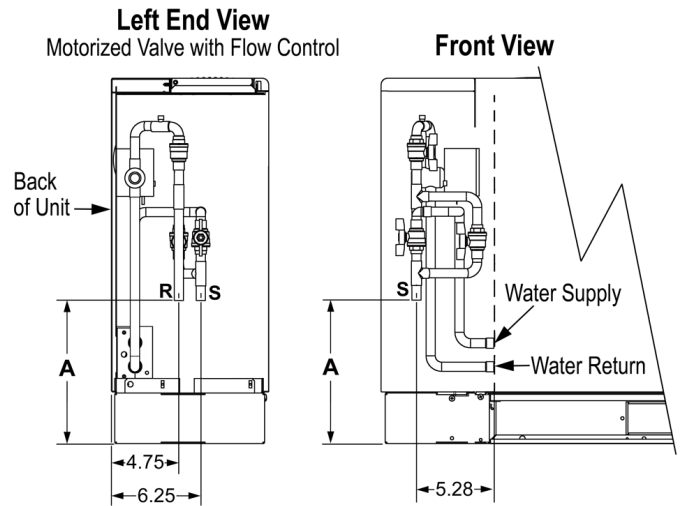

Figure 9: Left-Hand, Motorized Valve with Manual Valves



No.	Description
1	Measureflow device
2	2-way, normally closed motorized isolation valve
3	Air bleed vent
4	Supply, return, and bypass hand valve
5	Inlet-outlet flexible hoses (field-installed - not included)

NOTE 1: Optional flexible hose kits are provided with a 5/8" JIC FPT sweat adapter for field-installation to supply and return pipe stubs.

NOTE 2: On left-hand piping units, the water supply connection is on the left-hand piping units. On right hand piping units, the water supply is located at the bottom.

NOTE 3: Gray tinted areas are field-installed (not included).

Figure 10: Left-Hand, Manual Valve

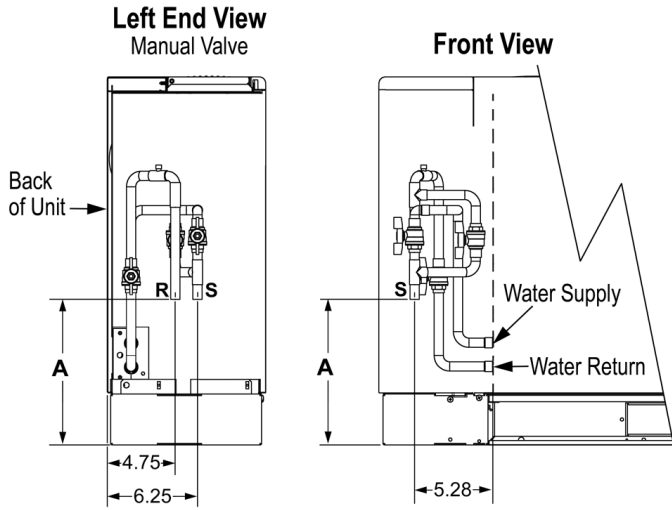
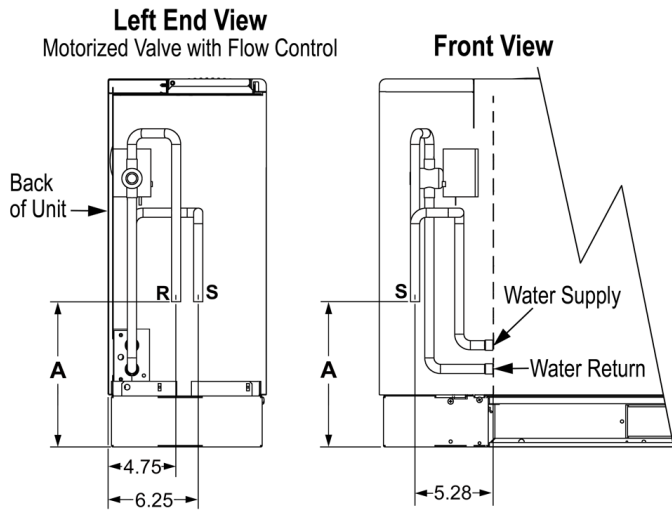

Figure 11: Left-Hand, Motorized Valve



Dimension "A"	
High Sill	Low Sill
9.81"	7.31"

- NOTE 1: Air bleed vent (not provided on all pipe packages).
- NOTE 2: Supply and return 5/8" O.D. copper tubing, (sweat connection stubs) are standard on unit piping and optional piping packages.
- NOTE 3: Optional flexible hose kits are provided with a 5/8" JIC FPT sweat adapter for field-installation to supply and return pipe stubs.

Piping Packages Dimensions – Right Hand

Figure 12: Right-Hand, Motorized Valve with Flow Control and Manual Valves

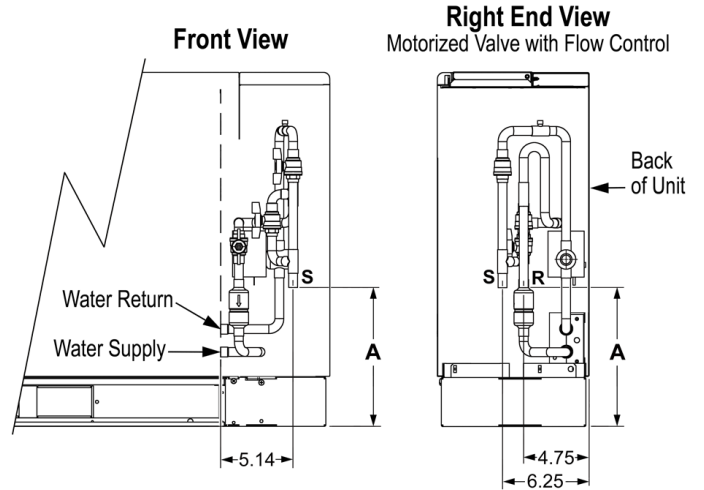

Figure 13: Right-Hand, Motorized Valve with Manual Valves

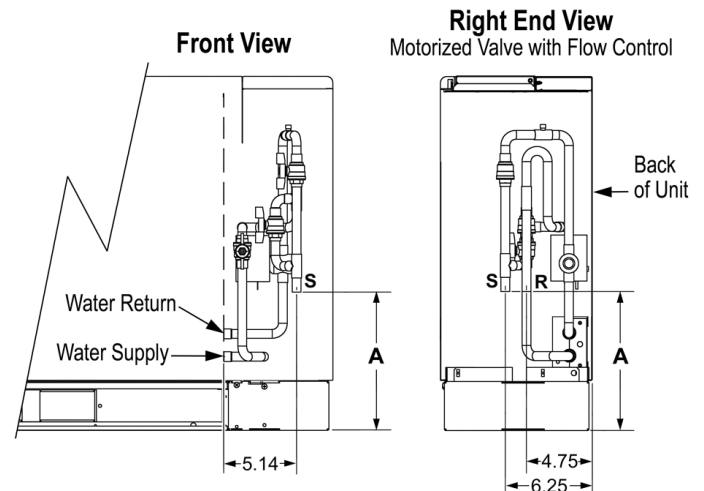

Table 4: Right-Hand, Manual Valve

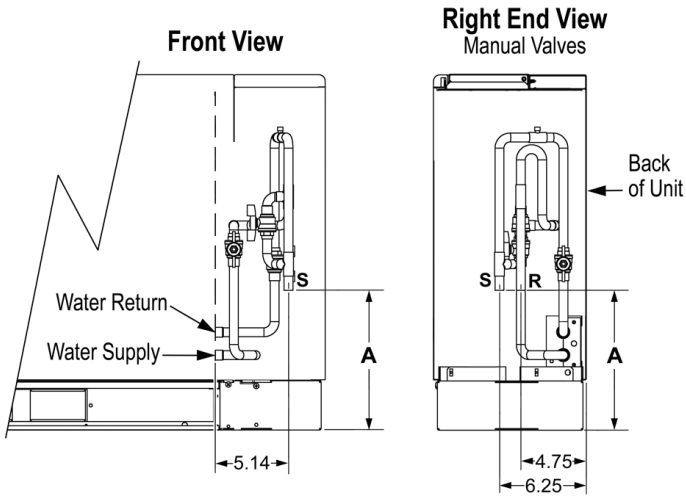
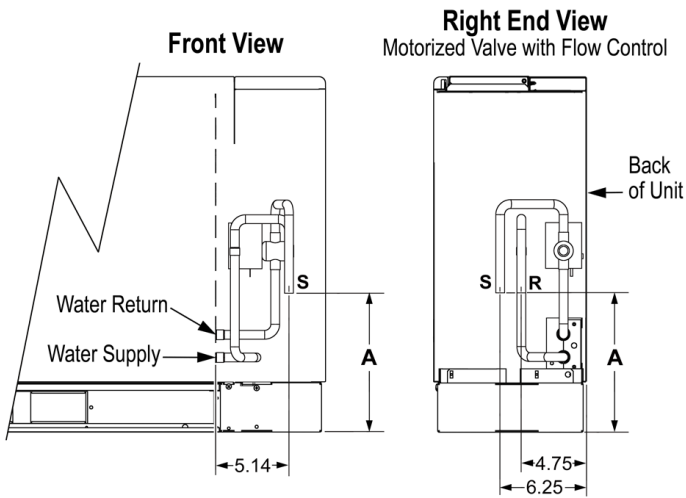

Figure 14: Right-Hand, Motorized Valve



Dimension "A"	
High Sill	Low Sill
9.81"	7.31"

- NOTE 1:** Air bleed vent (not provided on all pipe packages).
- NOTE 2:** Supply and return 5/8" O.D. copper tubing, (sweat connection stubs) are standard on unit piping and optional piping packages.
- NOTE 3:** Optional flexible hose kits are provided with a 5/8" JIC FPT sweat adapter for field-installation to supply and return pipe stubs.

Outdoor Air Dampers

Manually operated or motorized outside air damper assemblies are available to order as field-installed accessories and provide ventilation air.

Figure 15: Manual Outdoor Air Damper

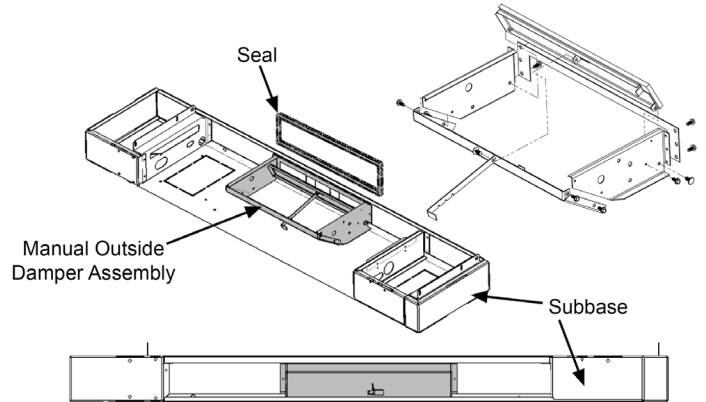
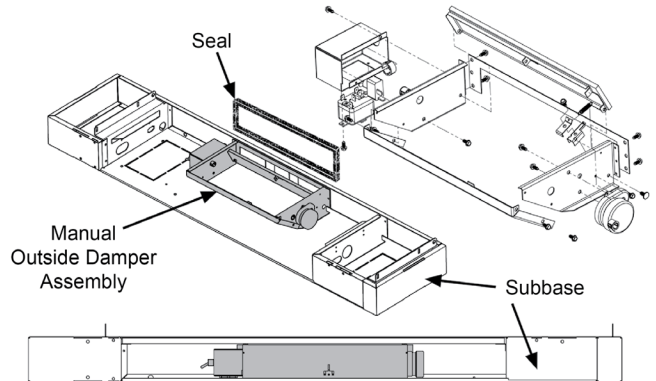

Figure 16: Motorized Outdoor Air Damper



Extended End Pocket (Option)

Optional extended cabinet end pocket for high sill units, provides 11" of additional area inside the left or right end pocket for piping or a field-installed pump.

Figure 17: Extended End Pocket (Option)

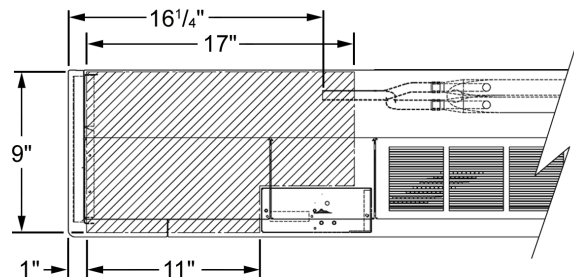

AHRI Performance Data

Table 5: AHRI Performance Data (Rated in Accordance with AHRI/ASHRAE/ISO Standard 13256-1) English (I-P) Units

Unit Size	Unit Voltage	Rated CFM	Rated GPM	Water Loop				Ground Loop (Geothermal)			
				Cooling - 86°F EWT		Heating - 68°F EWT		Cooling - 77°F EWT		Heating - 32°F EWT	
				Btu/h	EER	Btu/h	COP	Btu/h	EER	Btu/h	COP
007	115/60/1	335	1.9	7000	16.5	8300	5.8	7400	19.4	4800	3.6
	208-230/60/1			6800	16.2	7700	5.6	7100	19.4	4700	3.6
	265/60/1			6900	16.0	8500	5.7	7200	19.0	4800	3.5
009	115/60/1	375	2.4	8600	16.0	10700	5.5	9100	18.9	6500	3.6
	208-230/60/1			8600	15.4	10800	5.2	9100	18.1	6500	3.6
	265/60/1			8900	14.2	11200	4.9	9300	16.5	6800	3.3
012	115/60/1	365	2.9	11000	14.8	13900	4.9	11600	17.4	8300	3.4
	208-230/60/1			10700	14.4	13900	4.9	11500	17.4	8200	3.4
	265/60/1			10900	14.4	13800	4.9	11500	16.7	8300	3.3
015	208-230/60/1	535	3.7	14600	15.9	17900	5.0	15400	18.9	11200	3.6
	265/60/1			14500	14.9	18300	4.7	15300	17.3	11200	3.5
018	208-230/60/1	460	4.6	17700	14.2	24400	4.7	18400	16.6	15100	3.5
	265/60/1			17700	13.9	24400	4.7	18400	16.3	15100	3.5

Legend	
Btu/h	British Thermal Units per Hour
CFM	Airflow Rate, Cubic Feet per Minute
COP	Coefficient of Performance
EER	Energy Efficiency Ratio
EWT	Entering Water Temperature
GPM	Gallons per Minute

NOTE 1: Water loop cooling capacity is based on 80.6°F db, 66.2°F wb (27/19°C) EAT and 86°F (30°C) EWT.

NOTE 2: Water loop heating capacity is based on 68°F db, 59.0°F wb (20/15°C) EAT and 68°F (20°C) EWT.

NOTE 3: Ground loop cooling capacity is based on 80.6°F db, 66.2°F wb (27/19°C) EAT and 77°F (25°C) EWT.

NOTE 4: Ground loop heating capacity is based on 68°F db, 59.0°F wb (20/15°C) EAT and 32°F (0°C) EWT.

Capacity Data

Table 6: WSRC007 Capacity Data

EWT (°F)	GPM	WPD		Cooling - EAT 80/67°F					HEATING - EAT 70°F				
		PSI	ft of W.C.	Total (Btu/h)	Sensible (Btu/h)	Power Input (kW)	THR (Btu/h)	EER	Total (Btu/h)	Power Input (kW)	THA (Btu/h)	LAT (°F)	COP
25	1.2	1.1	2.6	Operation Not Recommended					3800	0.405	2400	80	2.8
	1.8	2.5	5.7						4000	0.407	2600	81	2.9
	2.3	4.0	9.1						4300	0.409	2900	82	3.1
30	1.2	1.1	2.5	8200	5200	0.198	8900	41.4	4300	0.411	2900	82	3.1
	1.8	2.4	5.6	8200	5200	0.178	8800	46.2	4500	0.413	3100	82	3.2
	2.3	3.9	9.0	8300	5200	0.161	8800	51.7	4800	0.415	3400	83	3.4
40	1.2	1.1	2.5	8100	5300	0.229	8900	35.3	5300	0.423	3900	85	3.7
	1.8	2.3	5.4	8100	5300	0.209	8800	38.8	5500	0.426	4000	85	3.8
	2.3	3.8	8.7	8200	5400	0.192	8900	42.8	5700	0.428	4200	86	3.9
50	1.2	1.0	2.4	7800	5300	0.267	8700	29.2	6200	0.436	4700	87	4.2
	1.8	2.3	5.3	7900	5300	0.247	8700	32.0	6500	0.439	5000	88	4.3
	2.3	3.7	8.5	8000	5300	0.230	8800	34.8	6700	0.441	5200	88	4.5
60	1.2	1.0	2.3	7500	5200	0.311	8600	24.1	7100	0.449	5600	90	4.6
	1.8	2.2	5.1	7600	5200	0.290	8600	26.2	7400	0.451	5900	90	4.8
	2.3	3.6	8.3	7700	5200	0.273	8600	28.2	7600	0.453	6100	91	4.9
70	1.2	1.0	2.3	7100	5000	0.358	8300	19.8	8000	0.460	6400	92	5.1
	1.8	2.2	5.0	7200	5000	0.338	8400	21.3	8300	0.462	6700	93	5.3
	2.3	3.5	8.1	7300	5000	0.321	8400	22.8	8500	0.464	6900	93	5.4
80	1.2	1.0	2.2	6800	4800	0.410	8200	16.6	8900	0.468	7300	94	5.6
	1.8	2.1	4.9	6800	4800	0.389	8100	17.5	9100	0.471	7500	95	5.7
	2.3	3.5	8.0	6900	4900	0.372	8200	18.6	9300	0.473	7700	96	5.8
90	1.2	1.0	2.2	6400	4600	0.464	8000	13.8	9700	0.474	8100	97	6.0
	1.8	2.1	4.9	6400	4700	0.444	7900	14.4	9900	0.476	8300	97	6.1
	2.3	3.4	7.8	6500	4700	0.427	8000	15.2	10100	0.478	8500	98	6.2
100	1.2	0.9	2.2	5900	4400	0.522	7700	11.3	Operation Not Recommended				
	1.8	2.1	4.8	6000	4500	0.502	7700	12.0					
	2.3	3.4	7.7	6100	4500	0.485	7800	12.6					
110	1.2	0.9	2.2	5400	4300	0.584	7400	9.2					
	1.8	2.1	4.7	5500	4300	0.563	7400	9.8					
	2.3	3.3	7.6	5600	4300	0.546	7500	10.3					
120	1.2	0.9	2.1	4800	4100	0.650	7000	7.4					
	1.8	2.0	4.7	4900	4100	0.630	7100	7.8					
	2.3	3.3	7.6	4900	4100	0.613	7000	8.0					

NOTE 1: Operation at or below 40°F EWT is based upon a 15% methanol antifreeze solution.

NOTE 2: Performance stated is at the rated power supply; performance may vary as the power supply varies from the rated.

NOTE 3: See performance correction tables for operating conditions other than those listed.

NOTE 4: Interpolation is permissible; extrapolation is not.

NOTE 5: For performance data outside the EAT listed, refer to the Daikin Select Tools™ (DST) selection program.

NOTE 6: Table does not reflect fan or pump power corrections for AHRI/ISO conditions.

NOTE 7: Data is based on unit at full load operation.

Legend			
Btu/h	British Thermal Units per Hour	GPM	Gallons per Minute
CFM	Airflow Rate, Cubic Feet per Minute	kW	Kilowatts
COP	Coefficient of Performance	LAT	Leaving Air Temperature
EAT	Entering Air Temperature	PSI	Pounds per square Inch
EER	Energy Efficiency Ratio	THA	Total Heat of Absorption
EWT	Entering Water Temperature	THR	Total Heat of Rejection
ft of W.C.	Feet of Water Column	WPD	Waterside Pressure Drop

Table 7: WSRC009 Capacity Data

EWT (°F)	GPM	WPD		Cooling - EAT 80/67°F					HEATING - EAT 70°F				
		PSI	ft of W.C.	Total (Btu/h)	Sensible (Btu/h)	Power Input (kW)	THR (Btu/h)	EER	Total (Btu/h)	Power Input (kW)	THA (Btu/h)	LAT (°F)	COP
25	1.5	1.4	3.3	Operation Not Recommended					5100	0.503	3400	83	3.0
	2.3	3.4	7.8						5600	0.513	3800	84	3.2
	3.0	5.7	13.2						6000	0.522	4200	85	3.4
30	1.5	1.4	3.3	10800	7000	0.238	11600	45.3	5700	0.511	4000	84	3.3
	2.3	3.3	7.7	10900	7000	0.231	11700	47.2	6200	0.521	4400	85	3.5
	3.0	5.6	13.0	11000	7000	0.225	11800	48.9	6600	0.530	4800	86	3.6
40	1.5	1.4	3.2	10800	7300	0.274	11700	39.5	6800	0.526	5000	87	3.8
	2.3	3.2	7.5	10800	7300	0.266	11700	40.5	7300	0.536	5500	88	4.0
	3.0	5.5	12.7	10900	7300	0.260	11800	41.9	7700	0.545	5800	89	4.1
50	1.5	1.3	3.1	10500	7300	0.321	11600	32.7	8000	0.541	6200	90	4.3
	2.3	3.1	7.3	10500	7300	0.313	11600	33.5	8500	0.551	6600	91	4.5
	3.0	5.3	12.3	10600	7300	0.307	11600	34.5	8900	0.560	7000	92	4.7
60	1.5	1.3	3.0	10000	7100	0.375	11300	26.6	9200	0.554	7300	93	4.9
	2.3	3.1	7.1	10100	7100	0.368	11400	27.4	9700	0.564	7800	94	5.0
	3.0	5.2	12.0	10200	7100	0.362	11400	28.2	10100	0.573	8100	95	5.2
70	1.5	1.3	3.0	9500	6900	0.435	11000	21.8	10400	0.565	8500	96	5.4
	2.3	3.0	6.9	9600	6900	0.428	11100	22.4	10900	0.575	8900	97	5.6
	3.0	5.1	11.8	9700	6900	0.421	11100	23.0	11300	0.584	9300	98	5.7
80	1.5	1.3	2.9	9000	6700	0.498	10700	18.1	11500	0.574	9500	98	5.9
	2.3	2.9	6.8	9100	6700	0.491	10800	18.5	12000	0.585	10000	99	6.0
	3.0	5.0	11.5	9100	6700	0.485	10800	18.8	12400	0.594	10400	100	6.1
90	1.5	1.2	2.9	8500	6500	0.565	10400	15.0	12600	0.581	10600	101	6.4
	2.3	2.9	6.7	8500	6500	0.558	10400	15.2	13100	0.591	11100	102	6.5
	3.0	4.9	11.4	8600	6500	0.551	10500	15.6	13500	0.600	11400	103	6.6
100	1.5	1.2	2.8	7900	6300	0.637	10100	12.4	Operation Not Recommended				
	2.3	2.9	6.6	8000	6300	0.630	10200	12.7					
	3.0	4.9	11.2	8000	6300	0.623	10100	12.8					
110	1.5	1.2	2.8	7200	6000	0.717	9600	10.0					
	2.3	2.8	6.5	7300	6100	0.709	9700	10.3					
	3.0	4.8	11.1	7400	6100	0.703	9800	10.5					
120	1.5	1.2	2.8	6400	5700	0.808	9200	7.9					
	2.3	2.8	6.5	6500	5700	0.801	9200	8.1					
	3.0	4.8	11.0	6500	5700	0.794	9200	8.2					

NOTE 1: Operation at or below 40°F EWT is based upon a 15% methanol antifreeze solution.

NOTE 2: Performance stated is at the rated power supply; performance may vary as the power supply varies from the rated.

NOTE 3: See performance correction tables for operating conditions other than those listed.

NOTE 4: Interpolation is permissible; extrapolation is not.

NOTE 5: For performance data outside the EAT listed, refer to the Daikin Select Tools selection program.

NOTE 6: Table does not reflect fan or pump power corrections for AHRI/ISO conditions.

NOTE 7: Data is based on unit at full load operation.

Legend			
Btu/h	British Thermal Units per Hour	GPM	Gallons per Minute
CFM	Airflow Rate, Cubic Feet per Minute	kW	Kilowatts
COP	Coefficient of Performance	LAT	Leaving Air Temperature
EAT	Entering Air Temperature	PSI	Pounds per square Inch
EER	Energy Efficiency Ratio	THA	Total Heat of Absorption
EWT	Entering Water Temperature	THR	Total Heat of Rejection
ft of W.C.	Feet of Water Column	WPD	Waterside Pressure Drop

Table 8: WSRC012 Capacity Data

EWT (°F)	GPM	WPD		Cooling - EAT 80/67°F					HEATING - EAT 70°F				
		PSI	ft of W.C.	Total (Btu/h)	Sensible (Btu/h)	Power Input (kW)	THR (Btu/h)	EER	Total (Btu/h)	Power Input (kW)	THA (Btu/h)	LAT (°F)	COP
25	2.0	2.6	5.9	Operation Not Recommended					6700	0.679	4400	87	2.9
	3.0	5.7	13.2						7300	0.694	4900	88	3.1
	4.0	10.2	23.5						7900	0.708	5500	90	3.3
30	2.0	2.5	5.8	13400	8300	0.345	14600	38.8	7400	0.693	5000	89	3.1
	3.0	5.6	13.0	13500	8400	0.339	14700	39.8	8000	0.707	5600	90	3.3
	4.0	10.0	23.1	13500	8400	0.333	14600	40.6	8500	0.722	6000	91	3.5
40	2.0	2.4	5.6	13500	8500	0.392	14800	34.5	8900	0.721	6400	92	3.6
	3.0	5.5	12.7	13500	8500	0.385	14800	35.1	9500	0.735	7000	94	3.8
	4.0	9.7	22.4	13500	8500	0.379	14800	35.6	10000	0.749	7400	95	3.9
50	2.0	2.4	5.5	13200	8500	0.448	14700	29.5	10500	0.748	7900	96	4.1
	3.0	5.3	12.3	13300	8500	0.441	14800	30.1	11000	0.762	8400	98	4.2
	4.0	9.5	21.9	13300	8500	0.435	14800	30.6	11600	0.776	8900	99	4.4
60	2.0	2.3	5.4	12800	8300	0.513	14600	24.9	12000	0.773	9400	100	4.5
	3.0	5.2	12.0	12900	8300	0.507	14600	25.5	12600	0.787	9900	102	4.7
	4.0	9.2	21.3	12900	8400	0.500	14600	25.8	13200	0.802	10500	103	4.8
70	2.0	2.3	5.2	12300	8100	0.588	14300	20.9	13600	0.797	10900	104	5.0
	3.0	5.1	11.8	12300	8100	0.581	14300	21.2	14200	0.811	11400	106	5.1
	4.0	9.0	20.9	12300	8100	0.575	14300	21.4	14700	0.825	11900	107	5.2
80	2.0	2.2	5.1	11600	7800	0.670	13900	17.3	15200	0.817	12400	108	5.5
	3.0	5.0	11.5	11600	7800	0.664	13900	17.5	15700	0.832	12900	110	5.5
	4.0	8.9	20.5	11600	7900	0.657	13800	17.7	16300	0.846	13400	111	5.6
90	2.0	2.2	5.1	10800	7500	0.760	13400	14.2	16600	0.835	13700	112	5.8
	3.0	4.9	11.4	10800	7500	0.754	13400	14.3	17200	0.849	14300	113	5.9
	4.0	8.7	20.2	10800	7500	0.747	13400	14.5	17700	0.864	14800	115	6.0
100	2.0	2.2	5.0	9900	7100	0.857	12800	11.6	Operation Not Recommended				
	3.0	4.9	11.2	10000	7100	0.851	12900	11.8					
	4.0	8.6	19.9	10000	7100	0.844	12900	11.8					
110	2.0	2.1	4.9	9000	6700	0.960	12300	9.4					
	3.0	4.8	11.1	9100	6700	0.954	12400	9.5					
	4.0	8.5	19.7	9100	6700	0.947	12300	9.6					
120	2.0	2.1	4.9	8200	6200	1.069	11900	7.7					
	3.0	4.8	11.0	8200	6300	1.063	11800	7.7					
	4.0	8.4	19.5	8300	6300	1.056	11900	7.9					

NOTE 1: Operation at or below 40°F EWT is based upon a 15% methanol antifreeze solution.

NOTE 2: Performance stated is at the rated power supply; performance may vary as the power supply varies from the rated.

NOTE 3: See performance correction tables for operating conditions other than those listed.

NOTE 4: Interpolation is permissible; extrapolation is not.

NOTE 5: For performance data outside the EAT listed, refer to the Daikin Select Tools selection program.

NOTE 6: Table does not reflect fan or pump power corrections for AHRI/ISO conditions.

NOTE 7: Data is based on unit at full load operation.

Legend			
Btu/h	British Thermal Units per Hour	GPM	Gallons per Minute
CFM	Airflow Rate, Cubic Feet per Minute	kW	Kilowatts
COP	Coefficient of Performance	LAT	Leaving Air Temperature
EAT	Entering Air Temperature	PSI	Pounds per square Inch
EER	Energy Efficiency Ratio	THA	Total Heat of Absorption
EWT	Entering Water Temperature	THR	Total Heat of Rejection
ft of W.C.	Feet of Water Column	WPD	Waterside Pressure Drop

Table 9: WSRC015 Capacity Data

EWT (°F)	GPM	WPD		Cooling - EAT 80/67°F					HEATING - EAT 70°F				
		PSI	ft of W.C.	Total (Btu/h)	Sensible (Btu/h)	Power Input (kW)	THR (Btu/h)	EER	Total (Btu/h)	Power Input (kW)	THA (Btu/h)	LAT (°F)	COP
25	2.5	1.7	4.0	Operation Not Recommended					9200	0.883	6200	86	3.1
	3.8	3.6	8.3						9900	0.895	6800	87	3.2
	5.0	5.8	13.5						10600	0.905	7500	88	3.4
30	2.5	1.7	3.9	17700	12500	0.422	19100	42.0	10200	0.903	7100	88	3.3
	3.8	3.5	8.2	17900	12600	0.393	19200	45.5	10900	0.914	7800	89	3.5
	5.0	5.7	13.3	18100	12700	0.367	19400	49.3	11500	0.925	8300	90	3.6
40	2.5	1.6	3.8	17600	12300	0.481	19200	36.6	12000	0.941	8800	91	3.7
	3.8	3.4	7.9	17800	12400	0.453	19300	39.3	12700	0.953	9400	92	3.9
	5.0	5.6	12.9	18000	12500	0.427	19500	42.2	13400	0.963	10100	93	4.1
50	2.5	1.6	3.7	17200	12100	0.559	19100	30.8	13900	0.978	10600	94	4.2
	3.8	3.3	7.7	17400	12200	0.531	19200	32.8	14600	0.989	11200	95	4.3
	5.0	5.4	12.5	17600	12300	0.505	19300	34.9	15300	1.000	11900	96	4.5
60	2.5	1.6	3.6	16700	11900	0.651	18900	25.7	15800	1.012	12300	97	4.6
	3.8	3.3	7.5	16900	12000	0.623	19000	27.1	16500	1.023	13000	98	4.7
	5.0	5.3	12.2	17100	12100	0.596	19100	28.7	17100	1.034	13600	99	4.8
70	2.5	1.5	3.5	16000	11600	0.752	18600	21.3	17500	1.043	13900	100	4.9
	3.8	3.2	7.4	16200	11700	0.724	18700	22.4	18200	1.054	14600	101	5.1
	5.0	5.2	12.0	16400	11800	0.698	18800	23.5	18900	1.064	15300	103	5.2
80	2.5	1.5	3.5	15200	11300	0.861	18100	17.7	19200	1.070	15500	103	5.3
	3.8	3.1	7.2	15400	11400	0.833	18200	18.5	19900	1.081	16200	104	5.4
	5.0	5.1	11.7	15600	11500	0.807	18400	19.3	20600	1.092	16900	105	5.5
90	2.5	1.5	3.4	14200	10900	0.979	17500	14.5	20800	1.093	17100	106	5.6
	3.8	3.1	7.1	14400	11000	0.950	17600	15.2	21500	1.104	17700	107	5.7
	5.0	5.0	11.6	14600	11100	0.924	17800	15.8	22100	1.115	18300	108	5.8
100	2.5	1.5	3.4	13200	10500	1.106	17000	11.9	Operation Not Recommended				
	3.8	3.0	7.0	13400	10600	1.078	17100	12.4					
	5.0	4.9	11.4	13600	10700	1.052	17200	12.9					
110	2.5	1.4	3.3	12100	10000	1.248	16400	9.7					
	3.8	3.0	6.9	12300	10100	1.220	16500	10.1					
	5.0	4.9	11.3	12500	10200	1.194	16600	10.5					
120	2.5	1.4	3.3	11000	9700	1.410	15800	7.8					
	3.8	3.0	6.9	11200	9800	1.382	15900	8.1					
	5.0	4.8	11.2	11400	9800	1.356	16000	8.4					

NOTE 1: Operation at or below 40°F EWT is based upon a 15% methanol antifreeze solution.

NOTE 2: Performance stated is at the rated power supply; performance may vary as the power supply varies from the rated.

NOTE 3: See performance correction tables for operating conditions other than those listed.

NOTE 4: Interpolation is permissible; extrapolation is not.

NOTE 5: For performance data outside the EAT listed, refer to the Daikin Select Tools selection program.

NOTE 6: Table does not reflect fan or pump power corrections for AHRI/ISO conditions.

NOTE 7: Data is based on unit at full load operation.

Legend			
Btu/h	British Thermal Units per Hour	GPM	Gallons per Minute
CFM	Airflow Rate, Cubic Feet per Minute	kW	Kilowatts
COP	Coefficient of Performance	LAT	Leaving Air Temperature
EAT	Entering Air Temperature	PSI	Pounds per square Inch
EER	Energy Efficiency Ratio	THA	Total Heat of Absorption
EWT	Entering Water Temperature	THR	Total Heat of Rejection
ft of W.C.	Feet of Water Column	WPD	Waterside Pressure Drop

Table 10: WSRC018 Capacity Data

EWT (°F)	GPM	WPD		Cooling - EAT 80/67°F					HEATING - EAT 70°F				
		PSI	ft of W.C.	Total (Btu/h)	Sensible (Btu/h)	Power Input (kW)	THR (Btu/h)	EER	Total (Btu/h)	Power Input (kW)	THA (Btu/h)	LAT (°F)	COP
25	3.0	2.4	5.5	Operation Not Recommended					12200	1.154	8300	94	3.1
	4.5	4.8	11.2						13300	1.195	9200	97	3.3
	6.0	8.0	18.6						14300	1.236	10100	99	3.4
30	3.0	2.3	5.4	21600	13000	0.529	23400	40.8	13500	1.193	9400	97	3.3
	4.5	4.8	11.0	21600	13000	0.522	23400	41.4	14500	1.233	10300	99	3.4
	6.0	7.9	18.3	21700	13100	0.515	23500	42.1	15600	1.274	11200	101	3.6
40	3.0	2.3	5.2	21600	12900	0.615	23700	35.1	16000	1.271	11700	102	3.7
	4.5	4.6	10.7	21600	13000	0.608	23700	35.5	17100	1.312	12600	104	3.8
	6.0	7.7	17.7	21700	13000	0.601	23800	36.1	18100	1.353	13500	106	3.9
50	3.0	2.2	5.1	21200	12800	0.719	23700	29.5	18600	1.350	14000	107	4.0
	4.5	4.5	10.4	21300	12800	0.712	23700	29.9	19700	1.391	15000	109	4.2
	6.0	7.5	17.3	21400	12900	0.704	23800	30.4	20700	1.431	15800	111	4.2
60	3.0	2.2	5.0	20600	12500	0.839	23500	24.6	21200	1.425	16300	112	4.4
	4.5	4.4	10.2	20700	12500	0.832	23500	24.9	22300	1.466	17300	115	4.5
	6.0	7.3	16.9	20800	12600	0.824	23600	25.2	23300	1.507	18200	117	4.5
70	3.0	2.1	4.9	19800	12100	0.975	23100	20.3	23700	1.494	18600	117	4.6
	4.5	4.3	9.9	19800	12100	0.967	23100	20.5	24700	1.535	19500	119	4.7
	6.0	7.1	16.5	19900	12100	0.960	23200	20.7	25800	1.576	20400	122	4.8
80	3.0	2.1	4.8	18700	11600	1.125	22500	16.6	26000	1.554	20700	122	4.9
	4.5	4.2	9.8	18800	11600	1.118	22600	16.8	27000	1.595	21600	124	5.0
	6.0	7.0	16.2	18900	11600	1.110	22700	17.0	28100	1.636	22500	126	5.0
90	3.0	2.0	4.7	17500	11000	1.289	21900	13.6	28000	1.602	22500	126	5.1
	4.5	4.2	9.6	17500	11000	1.282	21900	13.7	29000	1.642	23400	128	5.2
	6.0	6.9	15.9	17600	11100	1.274	22000	13.8	30100	1.683	24400	130	5.2
100	3.0	2.0	4.6	16100	10400	1.466	21100	11.0	Operation Not Recommended				
	4.5	4.1	9.5	16200	10400	1.459	21200	11.1					
	6.0	6.8	15.7	16300	10500	1.451	21300	11.2					
110	3.0	2.0	4.6	14700	9800	1.655	20400	8.9					
	4.5	4.1	9.4	14800	9800	1.647	20400	9.0					
	6.0	6.7	15.5	14800	9900	1.640	20400	9.0					
120	3.0	2.0	4.5	13200	9100	1.855	19500	7.1					
	4.5	4.0	9.3	13300	9200	1.847	19600	7.2					
	6.0	6.7	15.4	13300	9200	1.840	19600	7.2					

NOTE 1: Operation at or below 40°F EWT is based upon a 15% methanol antifreeze solution.

NOTE 2: Performance stated is at the rated power supply; performance may vary as the power supply varies from the rated.

NOTE 3: See performance correction tables for operating conditions other than those listed.

NOTE 4: Interpolation is permissible; extrapolation is not.

NOTE 5: For performance data outside the EAT listed, refer to the Daikin Select Tools selection program.

NOTE 6: Table does not reflect fan or pump power corrections for AHRI/ISO conditions.

NOTE 7: Data is based on unit at full load operation.

Legend			
Btu/h	British Thermal Units per Hour	GPM	Gallons per Minute
CFM	Airflow Rate, Cubic Feet per Minute	kW	Kilowatts
COP	Coefficient of Performance	LAT	Leaving Air Temperature
EAT	Entering Air Temperature	PSI	Pounds per square Inch
EER	Energy Efficiency Ratio	THA	Total Heat of Absorption
EWT	Entering Water Temperature	THR	Total Heat of Rejection
ft of W.C.	Feet of Water Column	WPD	Waterside Pressure Drop

Fan Performance

Table 11: Airflow vs. CFM - PSC Fan Motor

Unit Size	Fan Speed	SCFM	L/s
007	Low	305	144
	High	335	158
009	Low	350	165
	High	375	177
012	Low	330	156
	High	365	172
015	Low	405	191
	High	535	252
018	Low	300	142
	High	460	217

NOTE: Fan performance is based on a wet coil with clean 1/2" standard disposable filter.

Legend	
L/s	Liters per Second
SCFM	Standard Cubic Feet per Minute

Capacity Correction Factors

Table 12: Cooling Capacity Correction Table

Entering Air WB °F	Total Cooling Capacity	Sensible Cooling Capacity Multipliers - Entering DB °F						Power	Heat of Rejection
		65	70	75	80	80.6	85		
55	0.800	0.812	1.040	*	*	*	*	1.023	0.840
60	0.884	0.605	0.833	1.061	*	*	*	1.014	0.907
65	0.967		0.626	0.855	1.083	1.110	*	1.004	0.973
66.2	0.987		0.577	0.805	1.033	1.060	1.261	1.002	0.989
67	1.000		0.544	0.772	1.000	1.027	1.228	1.000	1.000
70	1.050			0.648	0.876	0.903	1.104	0.994	1.040
75	1.133				0.669	0.696	0.897	0.984	1.107

* Sensible capacity equals total capacity at conditions shown.

NOTE: The correction factor table is for reference only. For precise performance numbers, use Daikin Select Tools.

Table 13: Heating Capacity Correction Table

Entering Air Db °F	Heating Capacity	Power	Heat of Absorption
50	1.039	0.777	1.103
55	1.029	0.833	1.078
60	1.019	0.888	1.052
65	1.010	0.944	1.026
68	1.004	0.978	1.010
70	1.000	1.000	1.000
75	0.990	1.056	0.974
80	0.981	1.112	0.948
85	0.971	1.167	0.922

NOTE: The correction factor table is for reference only. For precise performance numbers, use Daikin Select Tools.

Electrical Data

Table 14: Standard PSC Motor

Unit Size	Voltage/Hz/Phase	Compressor		Fan Motor		Total Unit FLA	MCA	MOCP
		RLA	LRA	HP	FLA			
007	115/60/1	4.9	25.2	1/30	0.43	5.3	6.6	15
	208-230/60/1	2.4	13.4		0.41	2.8	3.4	15
	265/60/1	2.1	11.0	1/40	0.23	2.3	2.9	15
009	115/60/1	6.1	31.5	1/30	0.43	6.5	8.1	15
	208-230/60/1	3.4	16.5		0.41	3.8	4.7	15
	265/60/1	3.0	16.3	1/20	0.38	3.4	4.1	15
012	115/60/1	8.6	38.0	1/20	0.90	9.5	11.7	20
	208-230/60/1	4.3	20.6		0.47	4.8	5.8	15
	265/60/1	3.7	16.4		0.38	4.1	5.0	15
015	208-230/60/1	5.5	26.4	1/20	0.47	6.0	7.3	15
	265/60/1	4.8	21.5		0.38	5.2	6.4	15
018	208-230/60/1	7.2	41.8	1/20	0.47	7.7	9.5	15
	265/60/1	6.2	31.0		0.38	6.6	8.1	15

Table 15: Standard PSC Motor with Optional Electric Heater (Heat Pump not Running)

Unit Size	Voltage/Hz/Phase	Compressor		Fan Motor FLA	Electric Heat Nominal Rating (kW)	Voltage	Electric Heater		Total Unit FLA	Minimum Voltage	Minimum Circuit Amps	Maximum Fuse Size
		RLA	LRA				kW	FLA				
007	208-230/60/1	2.4	25.2	0.41	2.5	208	2.01	9.7	10.1	187	12.6	15
				0.41		230	2.46	10.7	11.1		13.9	15
	265/60/1	2.1	13.4	0.23		265	3.27	12.3	12.6	239	15.7	20
009	208-230/60/1	3.4	16.5	0.41	2.5	208	2.01	9.7	10.1	187	12.6	15
				0.41		230	2.46	10.7	11.1		13.9	15
	265/60/1	3.0	16.3	0.23		265	3.27	12.3	12.6	239	15.7	20
012	208-230/60/1	4.3	20.6	0.47	2.5	208	2.01	9.7	10.1	187	12.7	15
				0.47		230	2.46	10.7	11.2		14.0	15
	265/60/1	3.7	16.4	0.38		265	3.27	12.3	12.7	239	15.9	20
015	208-230/60/1	5.5	26.4	0.47	3.5	208	2.74	13.2	13.6	187	17.1	20
				0.47		230	3.35	14.6	15.0		18.8	20
	265/60/1	4.8	21.5	0.38		265	4.45	16.8	17.2	239	21.5	25
018	208-230/60/1	7.2	41.8	0.47	3.5	208	2.74	13.2	13.6	187	17.1	20
				0.47		230	3.35	14.6	15.0		18.8	20
	265/60/1	6.2	31.0	0.38		265	4.45	16.8	17.2	239	21.5	25

Typical Wiring Diagrams

Figure 18: 208-230/60/1 Without Electric Heat

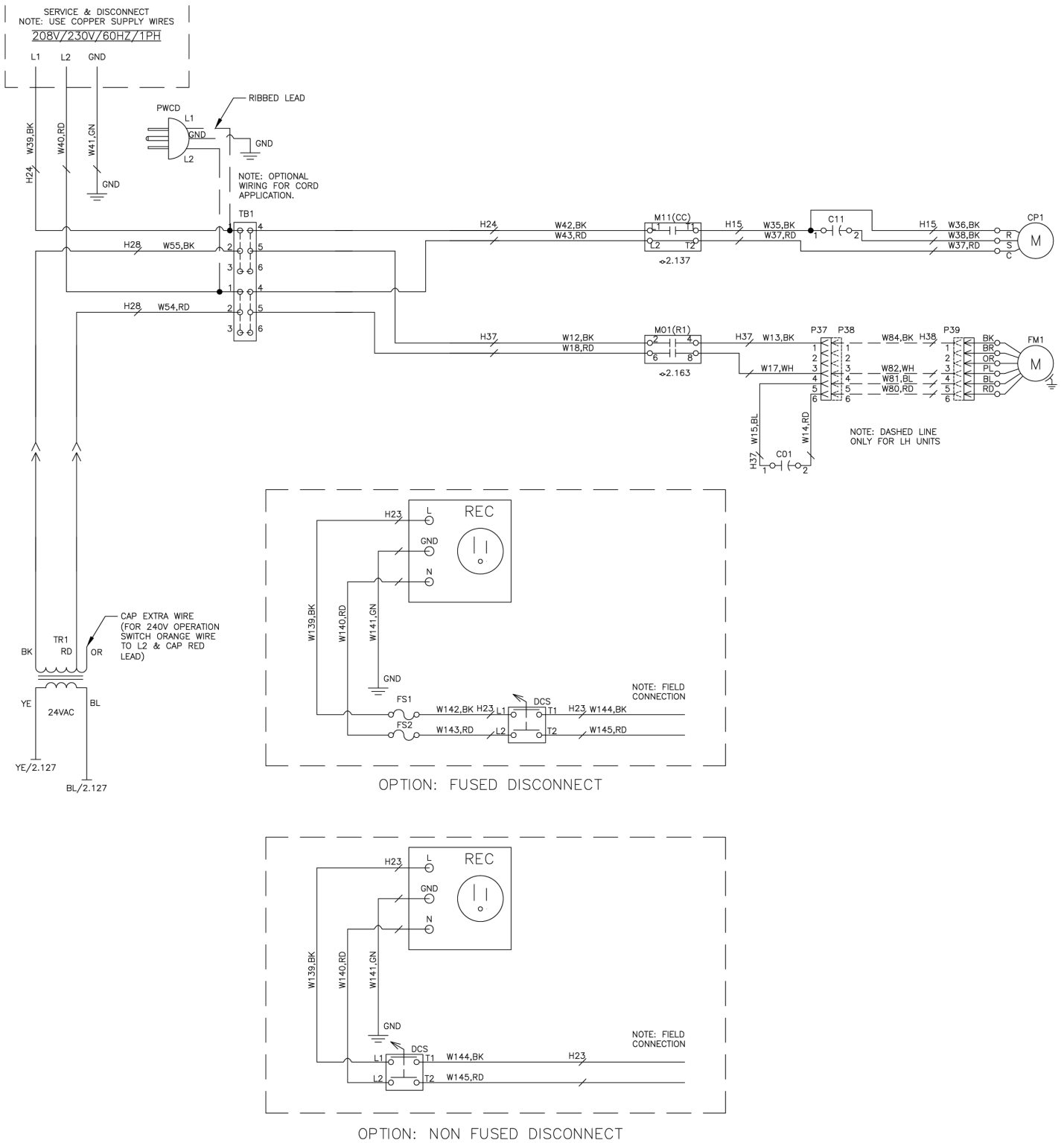

Figure 19: MicroTech Unit Control Without Electric Heat - 208-230/60/1

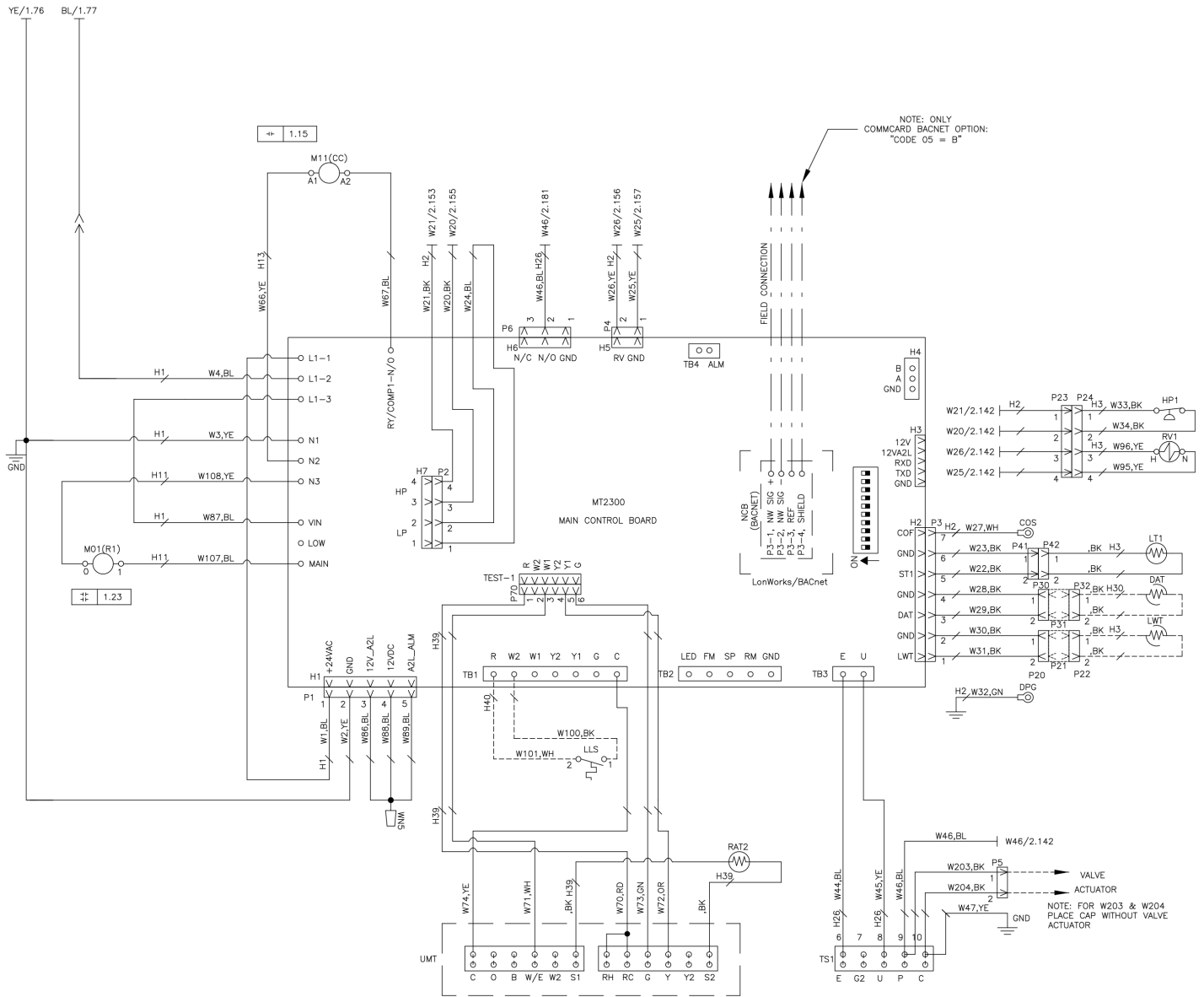

Figure 20: 208-230/60/1 with Electric Heat

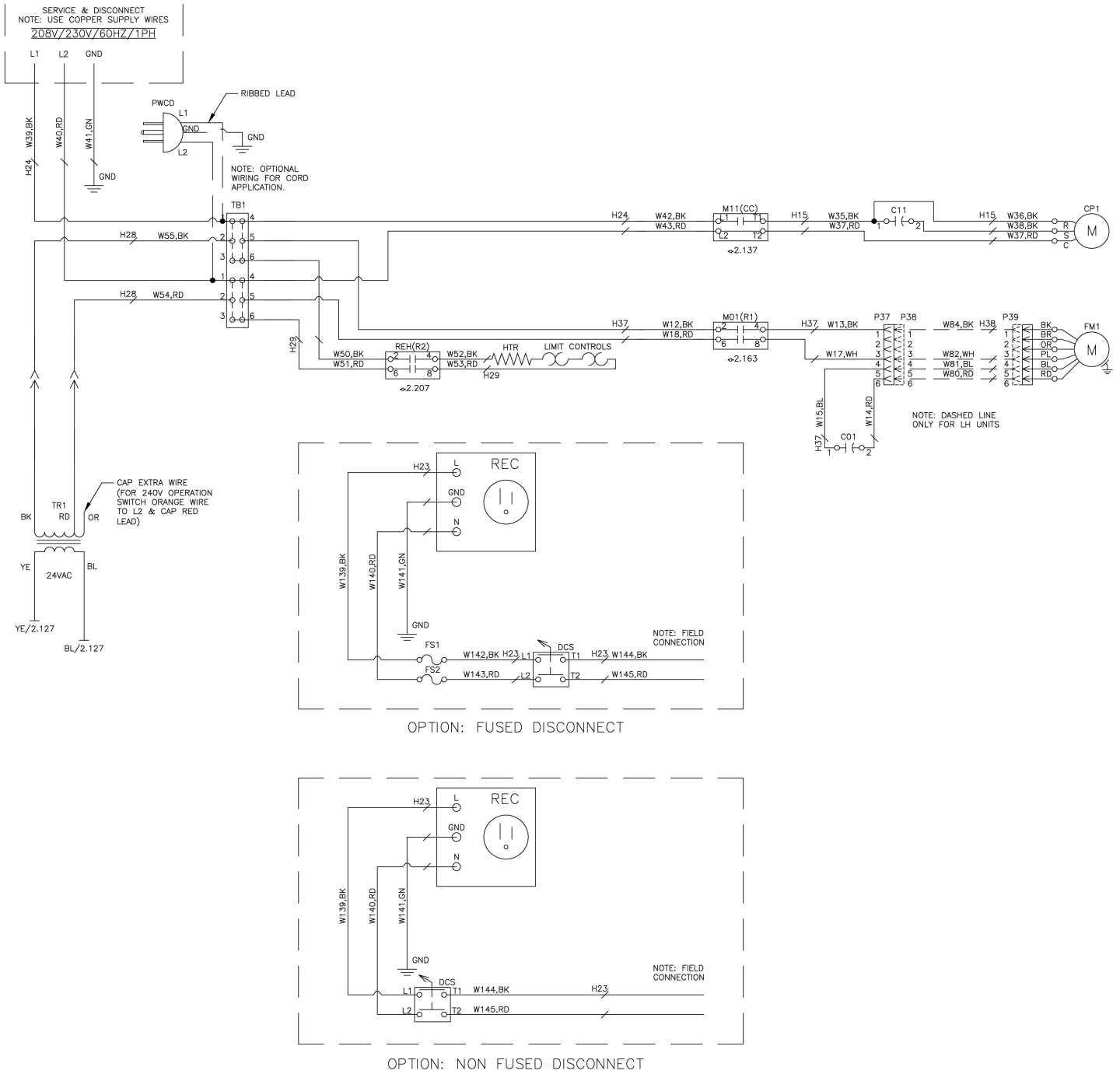
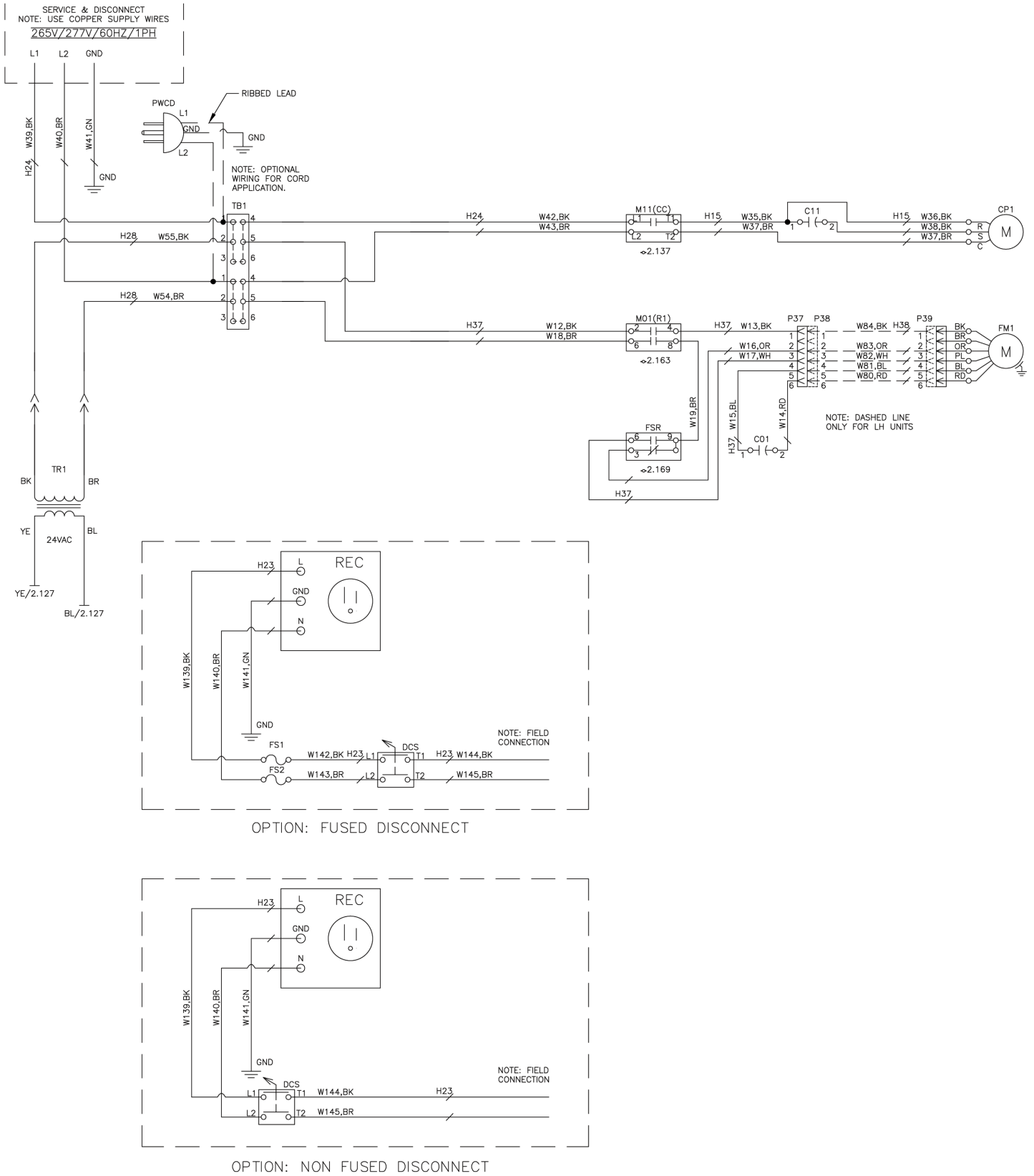

Figure 22: 265/60/1 with Wall Mounted Room Temperature Sensor



Wiring Schematics Legend for “Typical Wiring Diagrams”

LEGEND			
C01	Fan Motor Capacitor	LWT	Leaving Water Temperature Sensor
C11	Compressor Capacitor	M01	Fan Motor Contactor
CP1	Compressor	M11	Compressor Contactor
COS	Condensate Overflow Protection Sensor	MCB	Main Control Board
DAT	Discharge Air Temperature Sensor	NCB	Network Control Board
DCS	Disconnect Switch	NSB	Night Set Back Switch
DPG	Drain Pan Ground	OLP	Overload Protector - Compressor Motor
EB1	Expansion Control Board 1	P1-^	Wire Plug
EWT	Entering Water Temperature Sensor	PWCD	Power Cord
FHS	Fan High Speed Relay	RAT	Return Air Temperature Sensor
FM1	Fan Motor	RAT2	Return Air Temperature Sensor (Unit-MTD)
FS1-2	Fuse 1-2	REC	Receptacle
FSR	Fan Speed Relay	REH	Relay Electric Heat
FSS	Fan Speed Switch	RV1	Reversing Valve 1
GND	Ground	TB1	Terminal Block, Line Voltage
H1-^	Wire Harness	TR1	Transformer - Control
HP1	High Pressure Switch 1	TS1	Terminal Strip - EG2UPC
LLS	Low Limit Switch	UMT	Unit Mounted Thermostat
LP1	Low Pressure Switch 1	W1-^	Wire
LT1	Compressor Suction Line Temperature Sensor 1	WN1-^	Wire Nut

NOTE: Devices in legend may or may not be on unit.

Physical Data Table

Table 16: Physical Data

Unit Size		007	009	012	015	018		
Unit Dimensions H x W x D, in (mm)	Low Sill	22-1/2 x 46 x 10-3/4 (571.5 x 1168.4 x 273.05)			22-1/2 x 54 x 10-3/4 (571.5 x 1371.6 x 273.05)			
Unit Dimensions H x W x D ¹ , in (mm)	High Sill	25 x 46 x 10-3/4 (635 x 1168.4 x 273.05)			25 x 54 x 10-3/4 (635 x 1371.6 x 273.05)			
	High Sill with Extended End Pocket	25 x 58 x 10-3/4 (635 x 1473.2 x 273.05)			25 x 66 x 10-3/4 (635 x 1676.4 x 273.05)			
Unit Dimensions H x W x D, in (mm)	Chassis Only	20-1/2 x 44.7 x 10-1/2 (520.7 x 1135.38 x 266.7)			20-1/2 x 52.7 x 10-1/2 (520.7 x 1338.58 x 266.7)			
Fan Wheel - W x D, in (mm)		27-1/4 x 4-3/8 (692.15 x 111.13)			35-3/8 x 4-3/8 (898.53 x 111.13)			
Fan Motor (hp)	115/60/1	1/30	1/30	1/20	1/18			
	208-230/60/1							
	265/60/1	1/40	1/20					
Coil Face Area, ft ² (m ²)		1.67 (0.16)			2.22 (0.21)			
Coil Rows		2	2	3	2	3		
Voltage		All voltages						
R-32 Refrigerant Charge, oz (kg)		17.0 (0.48)	17.0 (0.48)	Left Hand 18.0 (0.23)	Right Hand 18.5 (0.24)	23.0 (0.65)	Left Hand 26.0 (0.74)	Right Hand 26.5 (0.75)
Filter Size W x D, in (mm)	Low Sill	23-3/4 x 8-3/4			31-3/4 x 8-3/4			
	High Sill	29-1/4 x 9-3/4			37-1/4 x 9-3/4			
Water Connections, Sweat Connections, O.D., in (mm)		5/8 (15.88)						
Condensate Connection, I.D., in (mm)		3/4 (19.05)						
Operating Weight, lbs (kg)		138 (62.60)	144 (65.32)	146 (66.22)		166 (75.30)	171 (77.56)	
Shipping Weight, lbs (kg)		158 (71.67)	164 (74.39)	166 (75.30)		196 (88.90)	201 (91.17)	

¹ Add 2" (50.8 mm), 4" (101.6 mm), or 6" (152.4 mm) to unit depth for optional rear extension.

Dimensional Drawings

Figure 24: Flat Top – High Sill, Left-Hand Piping – Unit Size 007 - 012

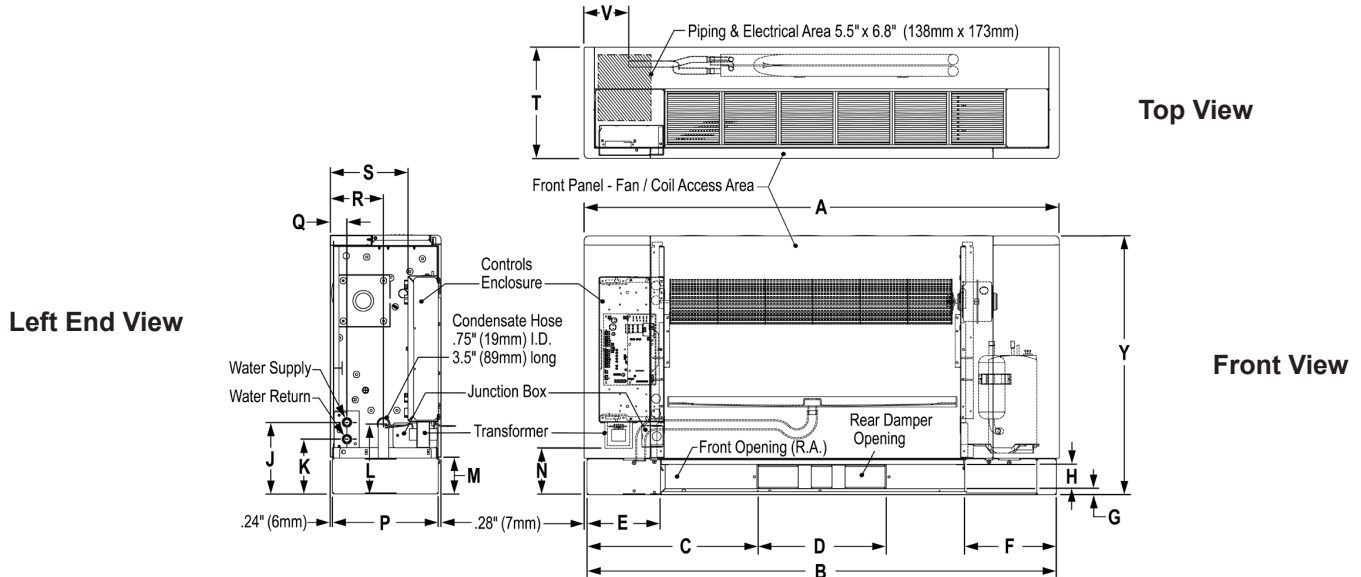

NOTE: The water supply connection is on the top of left-hand piping units and at the bottom on right-hand piping units.

Figure 25: Flat Top – High Sill, Right-Hand Piping – Unit Size 007 - 012

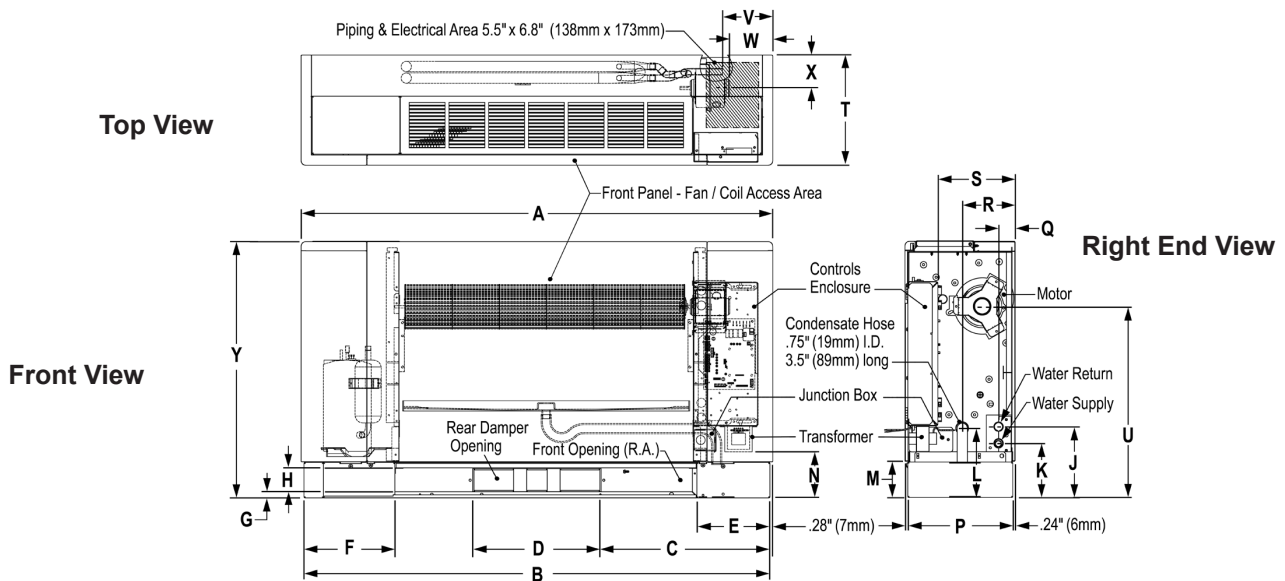

NOTE: The water supply connection is on the top of left hand piping units and at the bottom on right hand piping units.

Table 17: Dimensions³

Unit Size	A ¹	B	C	D	E	F	G	H	J	K	L	M
007-012	46" (1168 mm)	45 ³ / ₈ " (1153 mm)	16 ¹ / ₂ " (418 mm)	12 ¹ / ₂ " (318 mm)	7" (181 mm)	8 ⁷ / ₈ " (225 mm)	0.6" (14 mm)	2 ¹ / ₄ " (57 mm)	6 ⁷ / ₈ " (175 mm)	5 ¹ / ₅ " (132 mm)	6 ³ / ₄ " (172 mm)	3 ¹ / ₂ " (90 mm)
	N	P	Q	R	S	T ²	U	V	W	X	Y	
	4 ¹ / ₄ " (108 mm)	10 ¹ / ₄ " (260 mm)	1 ³ / ₅ " (41 mm)	5 ¹ / ₄ " (134 mm)	7 ¹ / ₂ " (192 mm)	10 ³ / ₄ " (273 mm)	18 ³ / ₄ " (476 mm)	4 ⁵ / ₈ " (118 mm)	4 ¹ / ₄ " (108 mm)	3 ¹ / ₄ " (83 mm)	25" (635 mm)	

¹ Add 12" to dimension "A" unit width for optional extended end pocket.

² Add 2", 4" or 6" to dimension "T" unit depth for optional rear extension (high sill units only).

³ Dimensions are approximate.

Figure 26: Flat Top – Low Sill, Left-Hand Piping – Unit Size 007 - 012

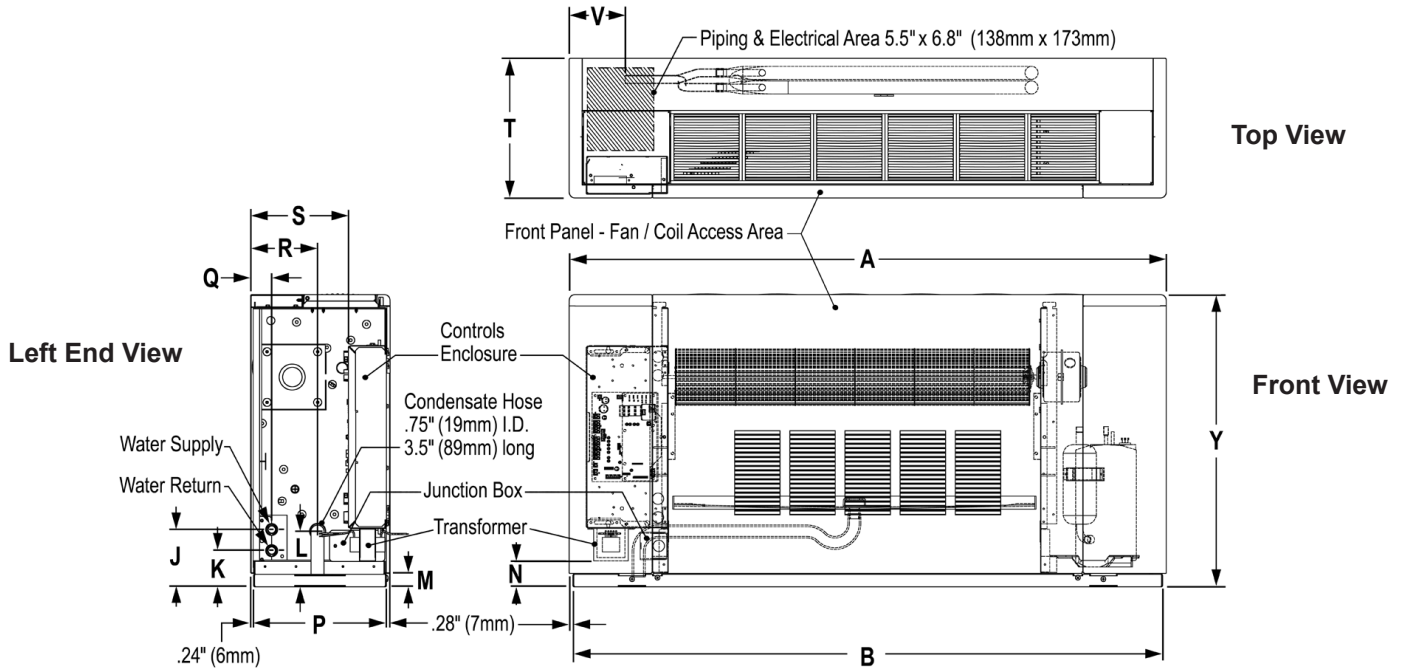

NOTE: The water supply connection is on the top of left hand piping units and at the bottom on right hand piping units.

Figure 27: Flat Top – Low Sill, Right-Hand Piping – Unit Size 007 - 012

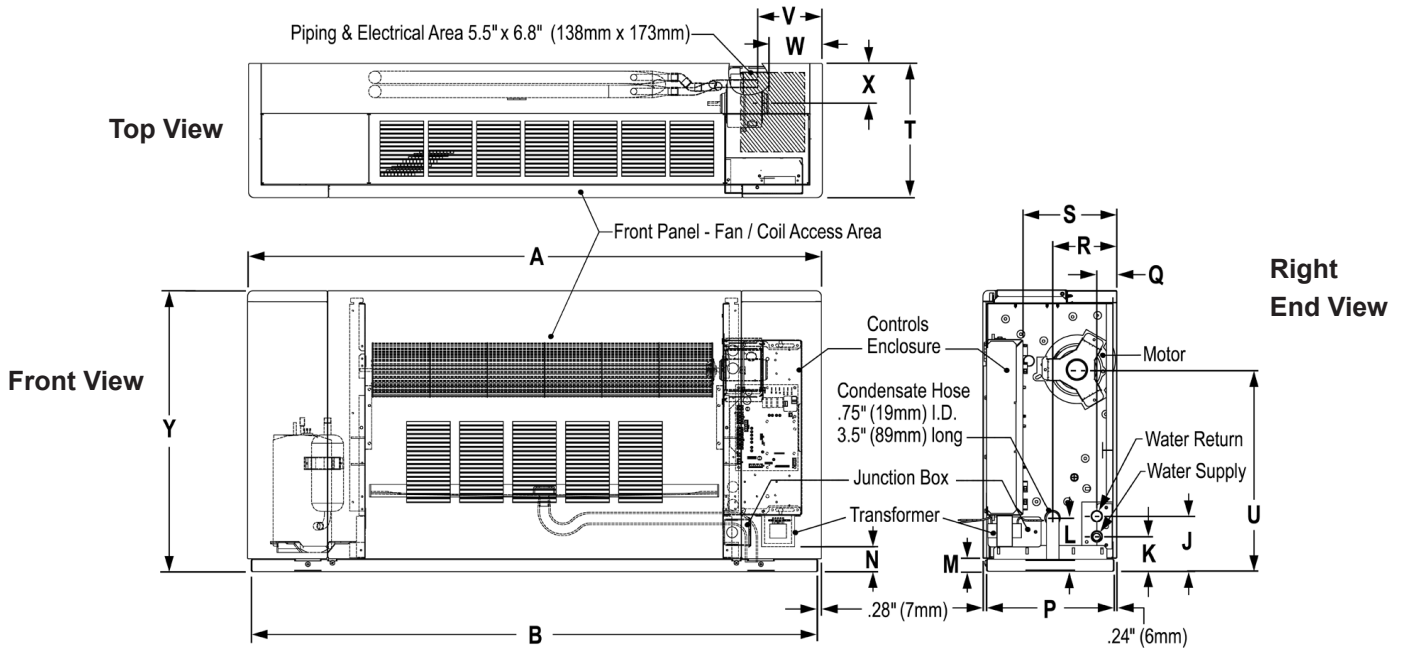

NOTE: The water supply connection is on the top of left hand piping units and at the bottom on right hand piping units.

Table 18: Dimensions¹

Unit Size	A	B	J	K	L	M	N	P	Q	R	S	T
007-012	46" (1168 mm)	45 3/8" (1153 mm)	4 3/8" (111 mm)	2 3/4" (70 mm)	4 1/4" (108 mm)	1" (26 mm)	1 3/4" (45 mm)	10 1/4" (260 mm)	1 3/5" (41 mm)	5 1/5" (131 mm)	7 1/2" (192 mm)	10 3/4" (273 mm)
	U	V	W	X	Y							
	16 1/4" (413 mm)	4 3/8" (118 mm)	4 1/4" (108 mm)	3 1/4" (83 mm)	22 1/2" (572 mm)							

¹ Dimensions are approximate.

Figure 28: Flat Top – High Sill, Left Hand Piping – Unit Size 015 - 018

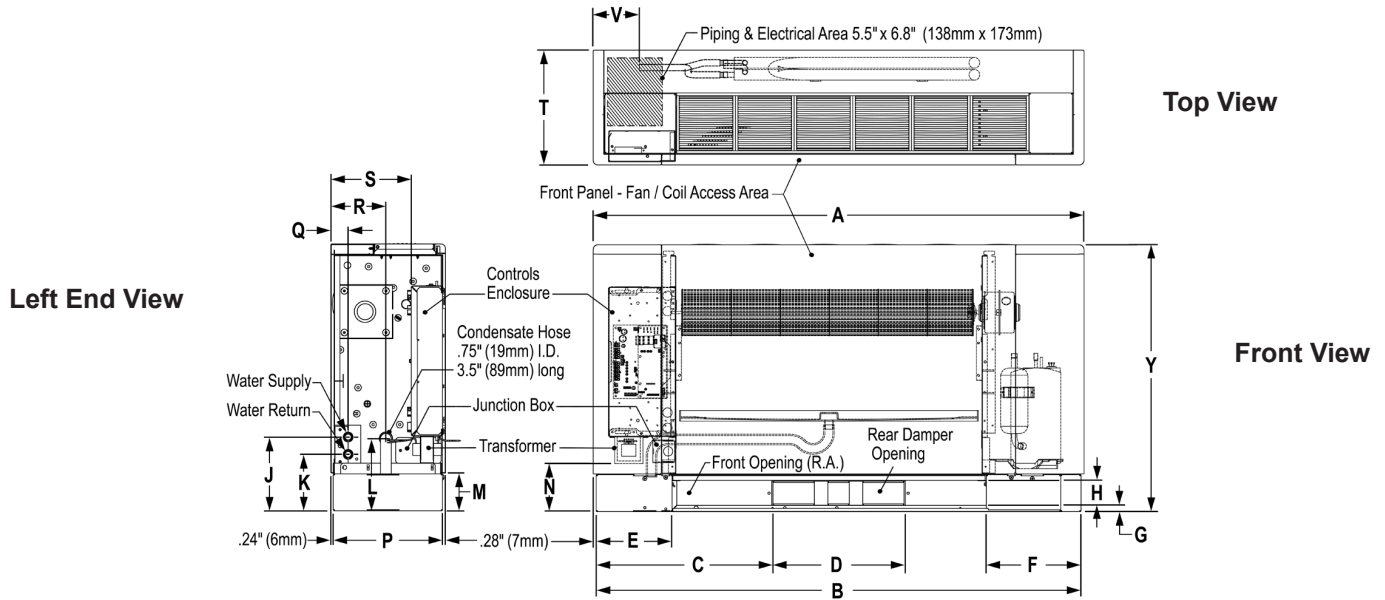

NOTE: The water supply connection is on the top of left hand piping units and at the bottom on right hand piping units.

Figure 29: Flat Top – High Sill, Right Hand Piping – Unit Size 015 - 018

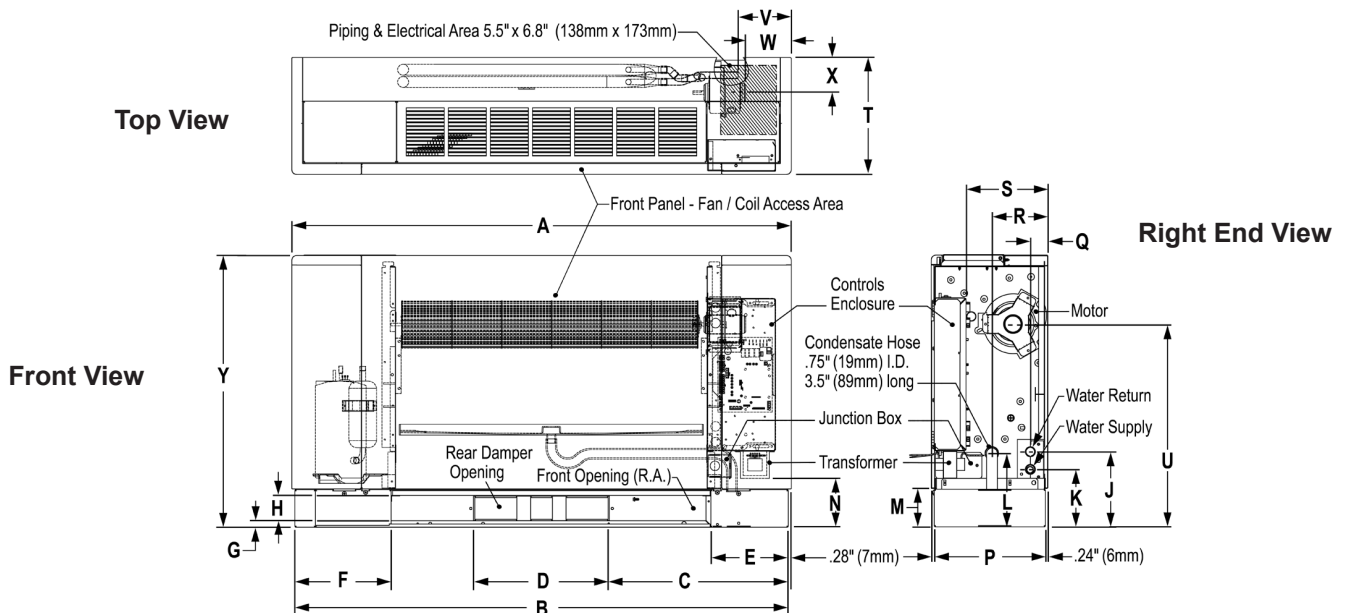

NOTE: The water supply connection is on the top of left hand piping units and at the bottom on right hand piping units.

Table 19: Dimensions³

Unit Size	A ¹	B	C	D	E	F	G	H	J	K	L	M
015-018	54" (1372 mm)	53 3/8" (1356 mm)	20 1/2" (519 mm)	12 1/2" (318 mm)	7" (181 mm)	8 3/8" (225 mm)	0.6" (14 mm)	2 1/4" (57 mm)	6 7/8" (175 mm)	5 1/5" (132 mm)	6 3/4" (172 mm)	3 1/2" (90 mm)
	N	P	Q	R	S	T ²	U	V	W	X	Y	
	4 1/4" (108 mm)	10 1/4" (260 mm)	1 3/5" (41 mm)	5 1/4" (134 mm)	7 1/2" (192 mm)	10 3/4" (273 mm)	18 3/4" (476 mm)	4 3/8" (118 mm)	4 1/4" (108 mm)	3 1/4" (83 mm)	25" (635 mm)	

¹ Add 12" to dimension "A" unit width for optional extended end pocket.

² Add 2", 4" or 6" to dimension "T" unit depth for optional rear extension (high sill units only).

³ Dimensions are approximate.

Figure 30: Flat Top – Low Sill, Left Hand Piping – Unit Size 015 - 018

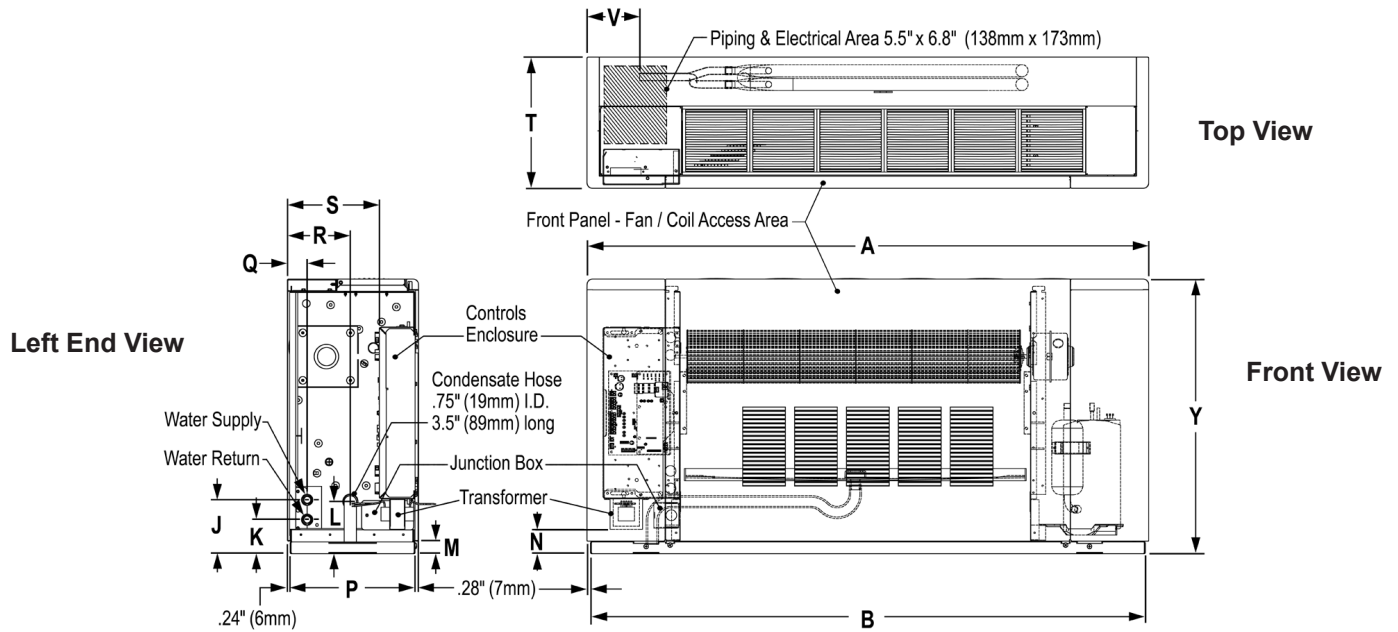

NOTE: The water supply connection is on the top of left hand piping units and at the bottom on right hand piping units.

Figure 31: Flat Top – Low Sill, Right-Hand Piping – Unit Size 015 - 018

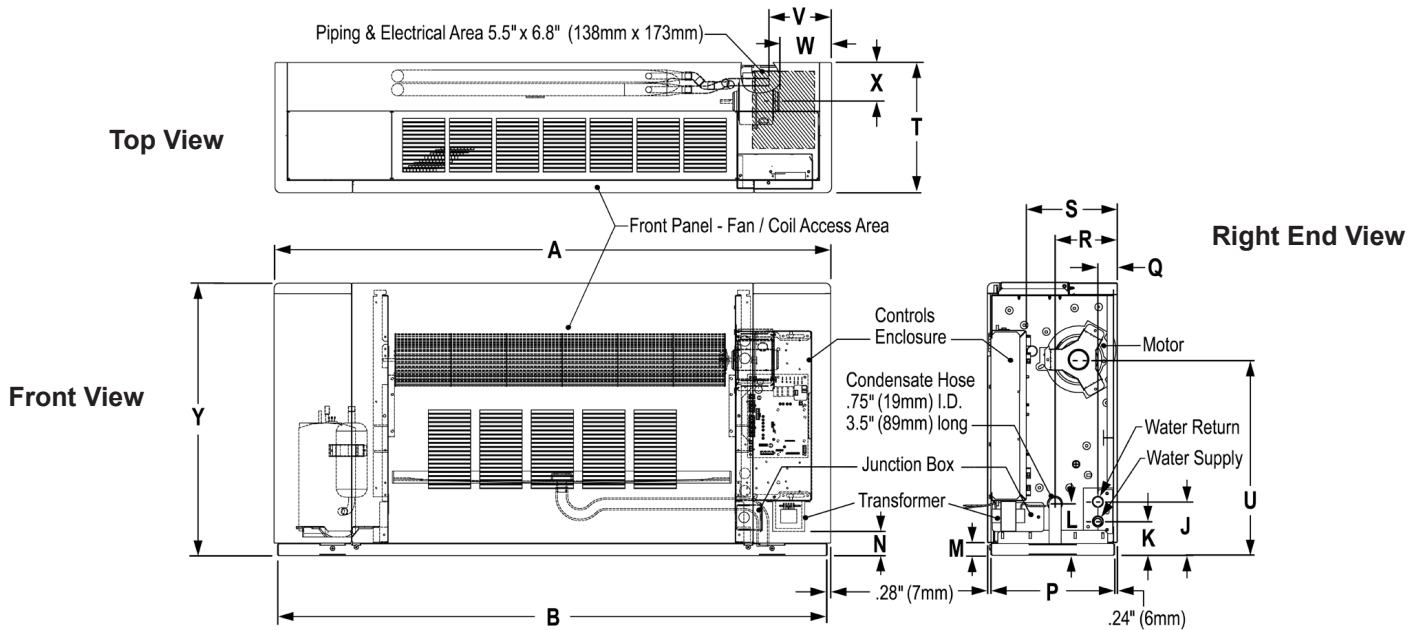

NOTE: The water supply connection is on the top of left hand piping units and at the bottom on right hand piping units.

Table 20: Dimensions¹

Unit Size	A	B	J	K	L	M	N	P	Q	R	S	T
015-018	54" (1372 mm)	53 ³ / ₈ " (1356 mm)	4 ³ / ₈ " (111 mm)	2 ³ / ₄ " (70 mm)	4 ¹ / ₄ " (108 mm)	1" (26 mm)	1 ³ / ₄ " (45 mm)	10 ¹ / ₄ " (260 mm)	1 ³ / ₅ " (41 mm)	5 ¹ / ₄ " (134 mm)	7 ¹ / ₂ " (192 mm)	10 ³ / ₄ " (273 mm)
	U	V	W	X	Y							
	16 ¹ / ₄ " (413 mm)	4 ⁵ / ₈ " (118 mm)	4 ¹ / ₄ " (108 mm)	3 ¹ / ₄ " (83 mm)	22 ¹ / ₂ " (572 mm)							

¹ Dimensions are approximate.

Figure 32: Slope Top – High Sill, Left-Hand Piping – Unit Size 007 - 012

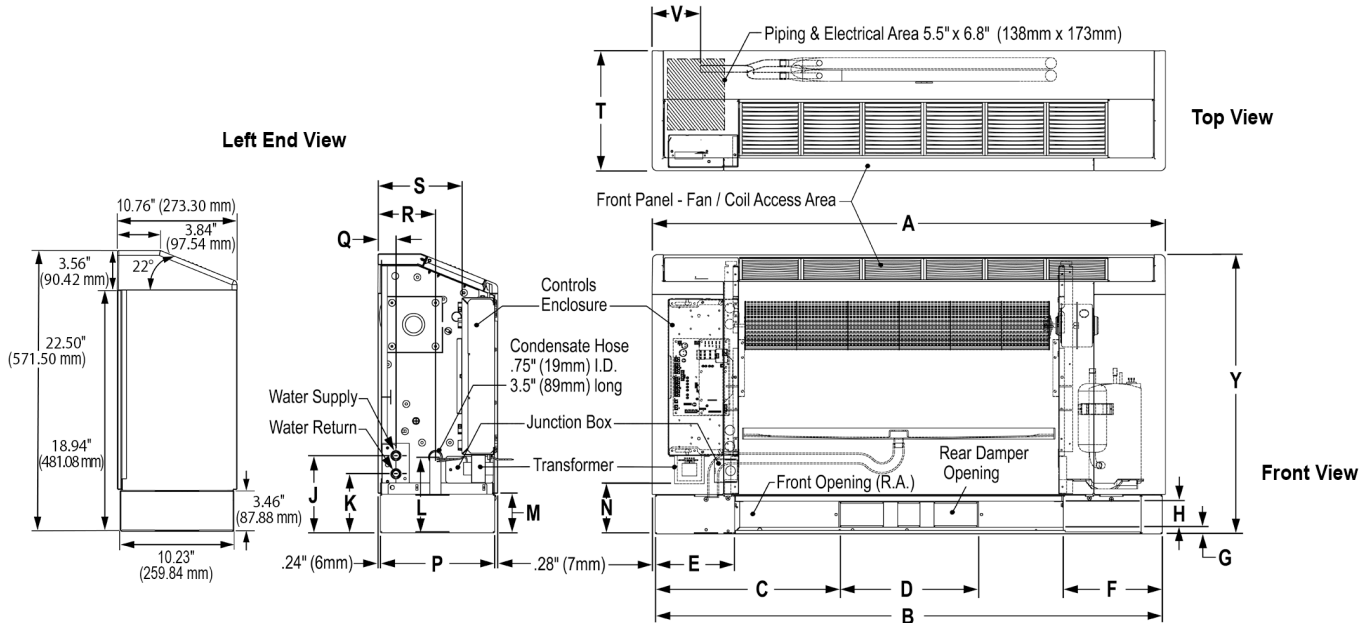

NOTE: The water supply connection is on the top of left hand piping units and at the bottom on right hand piping units.

Figure 33: Slope Top – High Sill, Right-Hand Piping – Unit Size 007 - 012

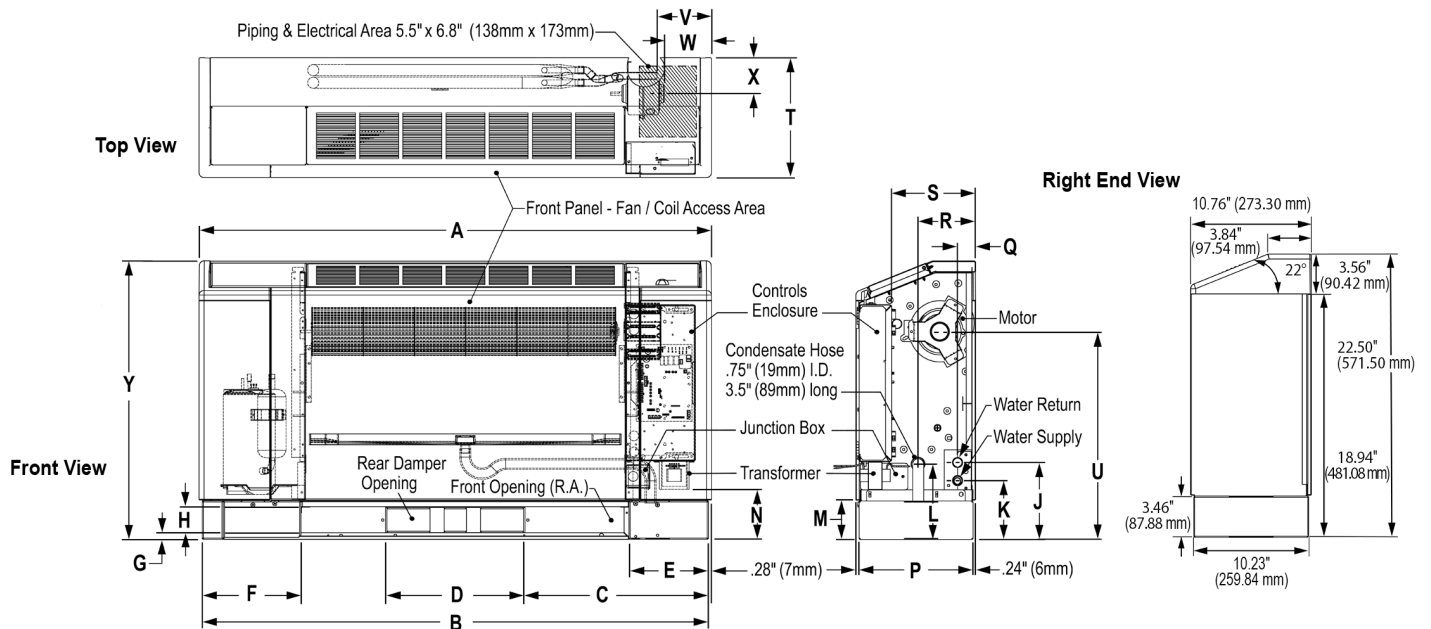

NOTE: The water supply connection is on the top of left hand piping units and at the bottom on right hand piping units.

Table 21: Dimensions³

Unit Size	A ¹	B	C	D	E	F	G	H	J	K	L	M
007-012	46" (1168 mm)	45 ³ / ₈ " (1153 mm)	16 ¹ / ₂ " (418 mm)	12 ¹ / ₂ " (318 mm)	7" (181 mm)	8 ³ / ₈ " (225 mm)	0.6" (14 mm)	2 ¹ / ₄ " (57 mm)	6 ⁷ / ₈ " (175 mm)	5 ¹ / ₅ " (132 mm)	6 ³ / ₄ " (172 mm)	3 ¹ / ₂ " (90 mm)
	N	P	Q	R	S	T ²	U	V	W	X	Y	
	4 ¹ / ₄ " (108 mm)	10 ¹ / ₄ " (260 mm)	1 ³ / ₅ " (41 mm)	5 ¹ / ₄ " (134 mm)	7 ¹ / ₂ " (192 mm)	10 ³ / ₄ " (273 mm)	18 ³ / ₄ " (476 mm)	4 ⁵ / ₈ " (118 mm)	4 ¹ / ₄ " (108 mm)	3 ¹ / ₄ " (83 mm)	25" (635 mm)	

¹ Add 12" to dimension "A" unit width for optional extended end pocket.
² Add 2", 4" or 6" to dimension "T" unit depth for optional rear extension (high sill units only).
³ Dimensions are approximate.

Figure 34: Slope Top – Low Sill, Left-Hand Piping – Unit Size 007 - 012

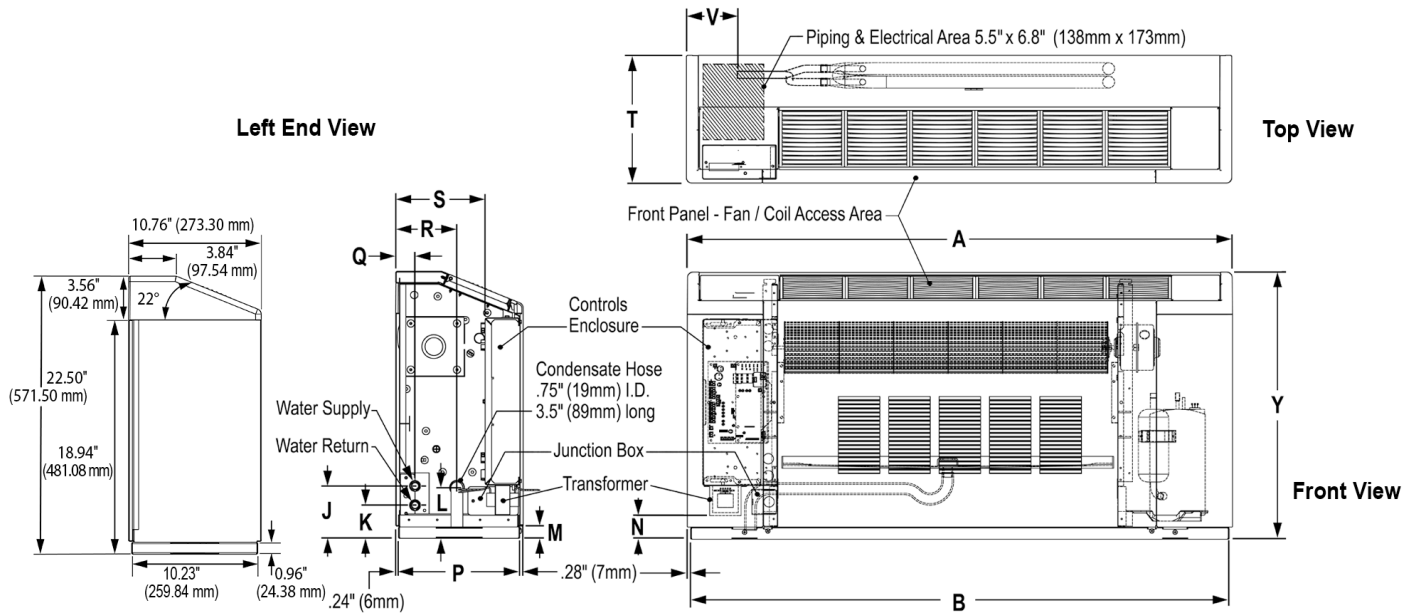

NOTE: The water supply connection is on the top of left hand piping units and at the bottom on right hand piping units.

Figure 35: Slope Top – Low Sill, Right-Hand Piping – Unit Size 007 - 012

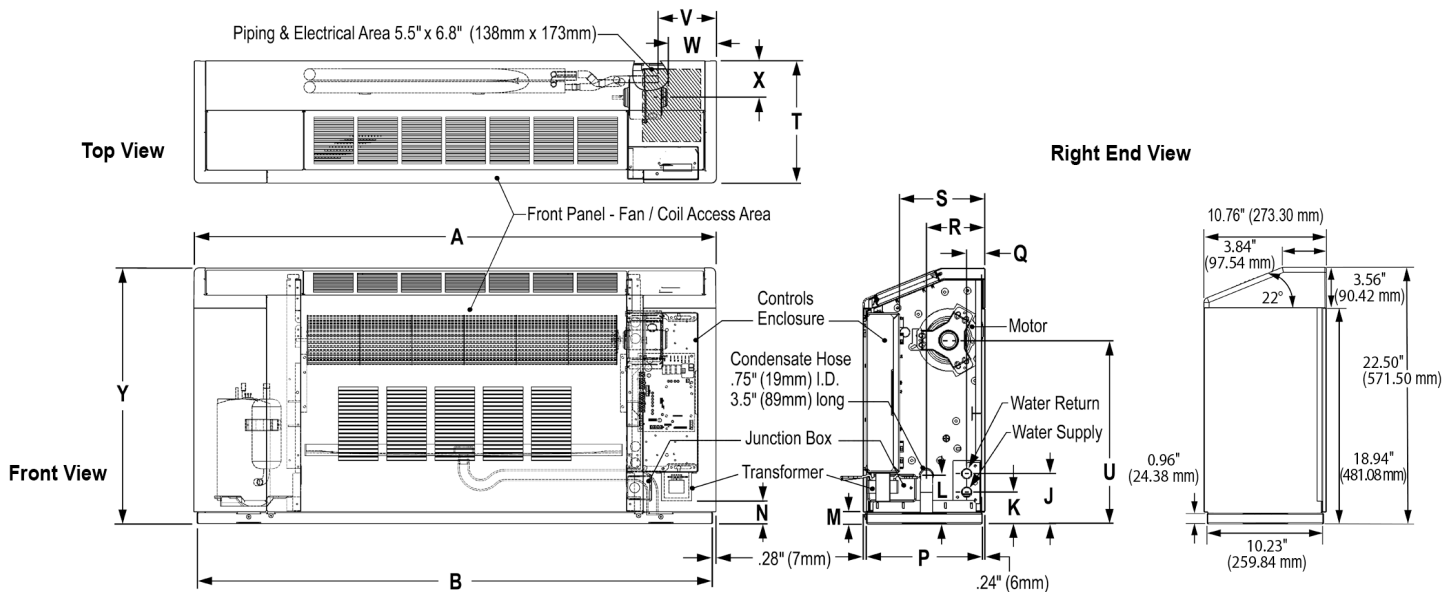

NOTE: The water supply connection is on the top of left hand piping units and at the bottom on right hand piping units.

Table 22: Dimensions¹

Unit Size	A	B	C	D	E	F	G	H	J	K	L	M
007-012	46" (1168 mm)	45 ³ / ₈ " (1153 mm)	16 ¹ / ₂ " (418 mm)	12 ¹ / ₂ " (318 mm)	7" (181 mm)	8 ⁵ / ₁₆ " (225 mm)	0.6" (14 mm)	2 ¹ / ₄ " (57 mm)	6 ⁷ / ₈ " (175 mm)	5 ¹ / ₅ " (132 mm)	6 ³ / ₄ " (172 mm)	3 ¹ / ₂ " (90 mm)
	N	P	Q	R	S	T	U	V	W	X	Y	
	4 ¹ / ₄ " (108 mm)	10 ¹ / ₄ " (260 mm)	1 ³ / ₅ " (41 mm)	5 ¹ / ₄ " (134 mm)	7 ¹ / ₂ " (192 mm)	10 ³ / ₄ " (273 mm)	18 ³ / ₄ " (476 mm)	4 ⁵ / ₈ " (118 mm)	4 ¹ / ₄ " (108 mm)	3 ¹ / ₄ " (83 mm)	25" (635 mm)	

¹ Dimensions are approximate.

Figure 36: Slope Top – High Sill, Left-Hand Piping – Unit Size 015 - 018

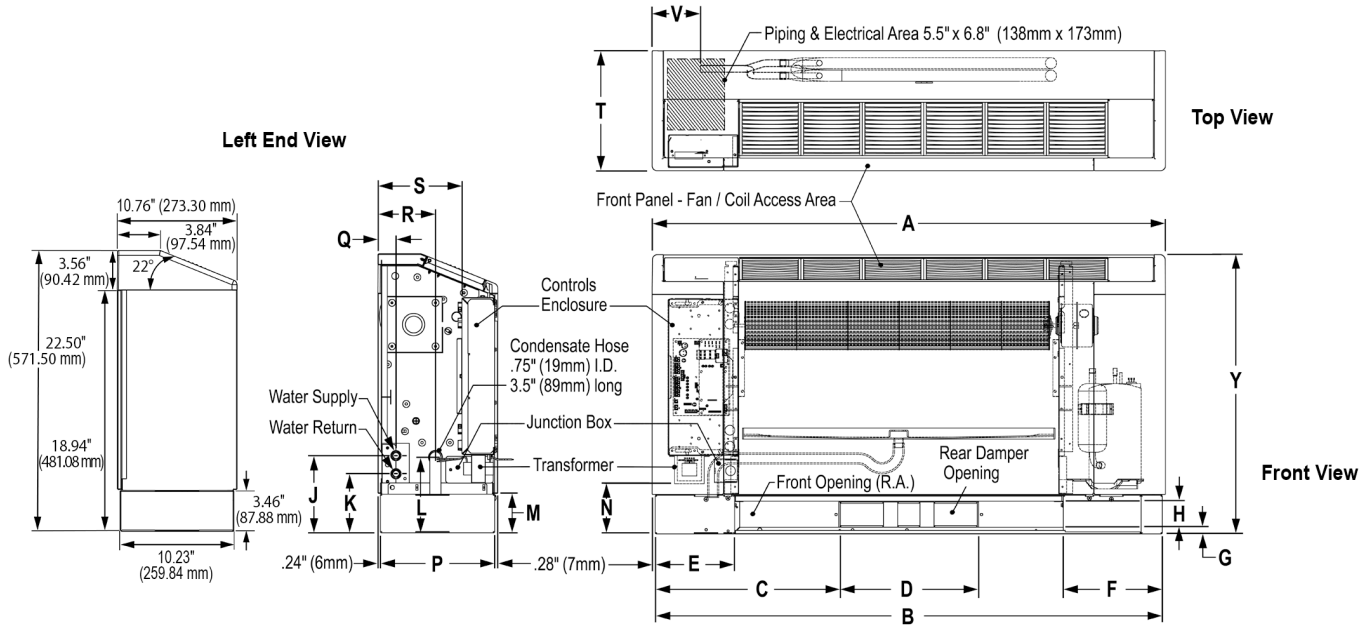

NOTE: The water supply connection is on the top of left hand piping units and at the bottom on right hand piping units.

Figure 37: Slope Top – High Sill, Right Hand Piping – Unit Size 015 - 018

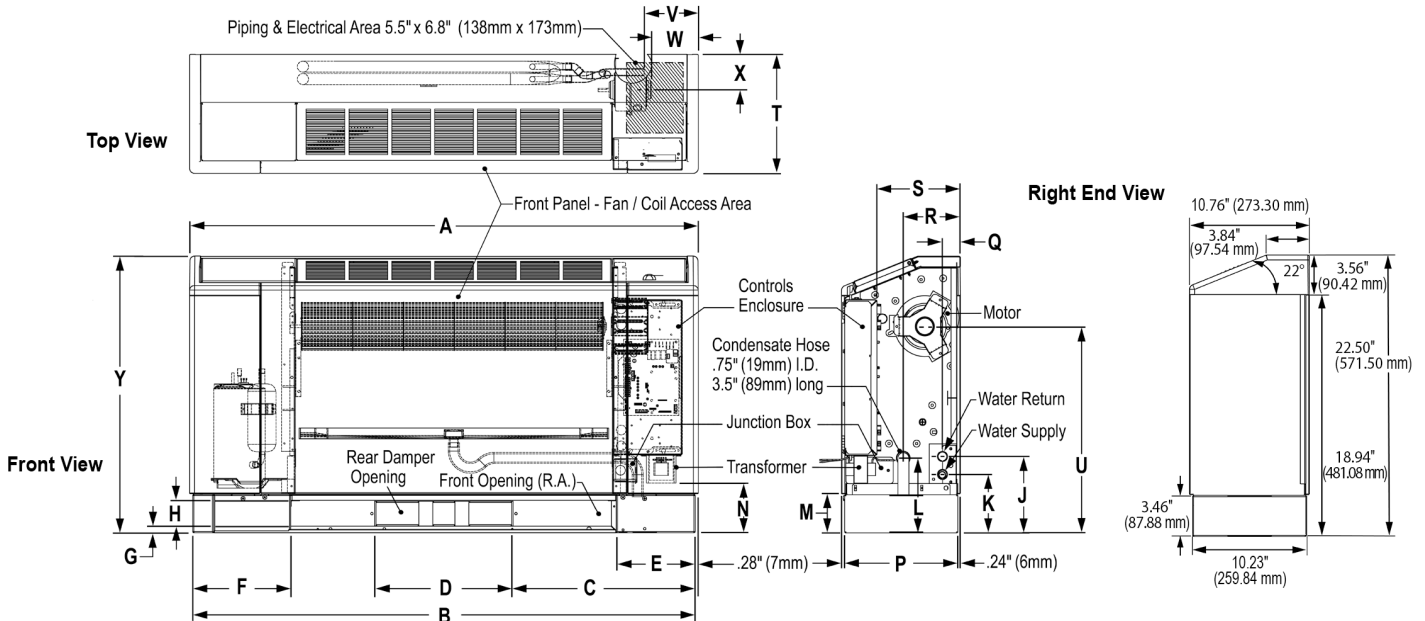

NOTE: The water supply connection is on the top of left hand piping units and at the bottom on right hand piping units.

Table 23: Dimensions³

Unit Size	A ¹	B	C	D	E	F	G	H	J	K	L	M
015-018	54" (1372 mm)	53 ³ / ₈ " (1356 mm)	20 ¹ / ₂ " (519 mm)	12 ¹ / ₂ " (318 mm)	7" (181 mm)	8 ⁷ / ₈ " (225 mm)	0.6" (14 mm)	2 ¹ / ₄ " (57 mm)	6 ⁷ / ₈ " (175 mm)	5 ¹ / ₅ " (132 mm)	6 ³ / ₄ " (172 mm)	3 ¹ / ₂ " (90 mm)
	N	P	Q	R	S	T ²	U	V	W	X	Y	
	4 ¹ / ₄ " (108 mm)	10 ¹ / ₄ " (260 mm)	1 ³ / ₅ " (41 mm)	5 ¹ / ₄ " (134 mm)	7 ¹ / ₂ " (192 mm)	10 ³ / ₄ " (273 mm)	18 ³ / ₄ " (476 mm)	4 ⁵ / ₈ " (118 mm)	4 ¹ / ₄ " (108 mm)	3 ¹ / ₄ " (83 mm)	25" (635 mm)	

¹ Add 12" to dimension "A" unit width for optional extended end pocket.

² Add 2", 4" or 6" to dimension "T" unit depth for optional rear extension (high sill units only).

³ Dimensions are approximate.

Figure 38: Slope Top – Low Sill, Left-Hand Piping – Unit Size 015 - 018

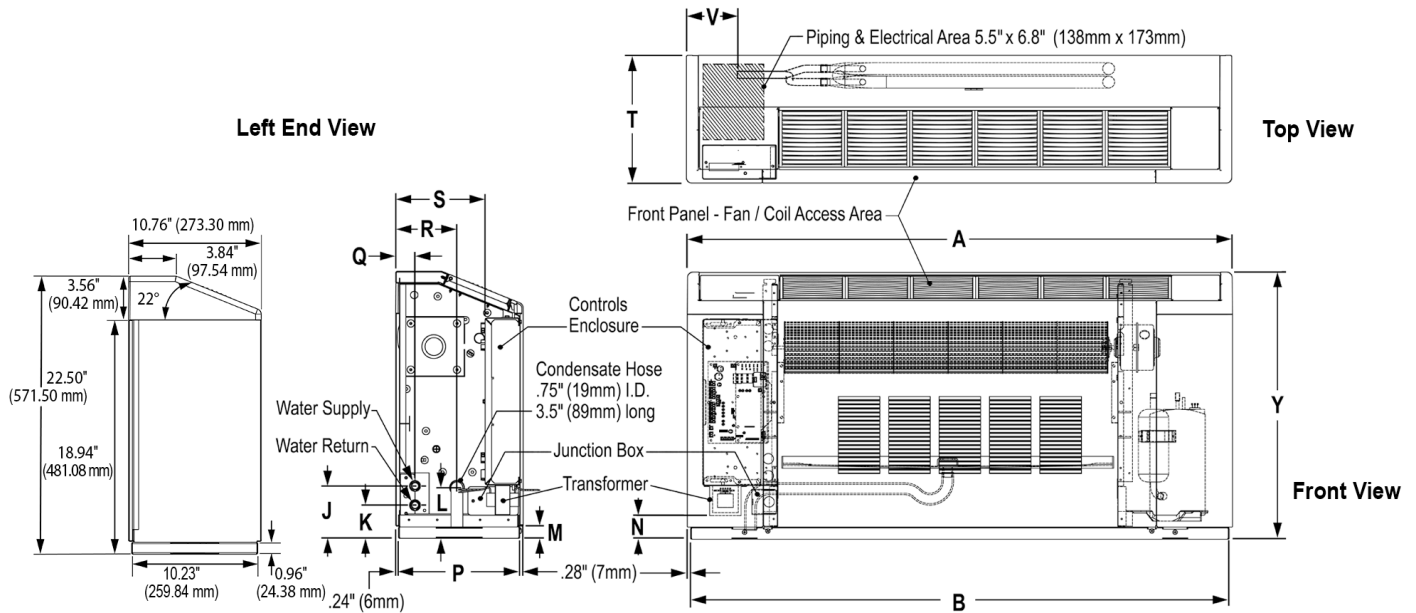

NOTE: The water supply connection is on the top of left hand piping units and at the bottom on right hand piping units.

Figure 39: Slope Top – Low Sill, Right Hand Piping – Unit Size 015 - 018

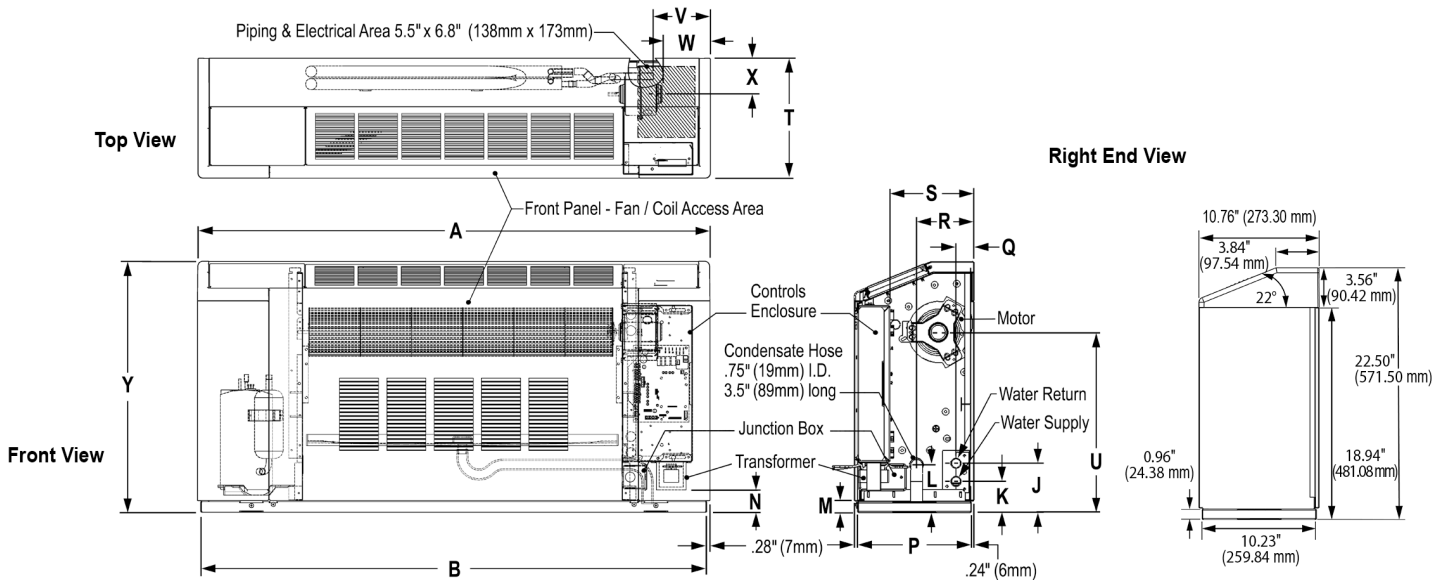

NOTE: The water supply connection is on the top of left hand piping units and at the bottom on right hand piping units.

Table 24: Dimensions¹

Unit Size	A	B	J	K	L	M	N	P	Q	R	S	T
015-018	54" (1372 mm)	53 3/8" (1356 mm)	4 3/8" (111 mm)	2 3/4" (70 mm)	4 1/4" (108 mm)	1" (26 mm)	1 1/4" (45 mm)	10 1/4" (260 mm)	1 3/5" (41 mm)	5 1/4" (134 mm)	7 1/2" (192 mm)	10 3/4" (273 mm)
	U	V	W	X	Y							
	16 1/4" (413 mm)	4 3/8" (118 mm)	4 1/4" (108 mm)	3 1/4" (83 mm)	22 1/2" (572 mm)							

¹ Dimensions are approximate.

System Considerations

Power Supply

Verify that the available power supply matches the electrical voltage and phase of the unit as shown on the unit nameplate. All field wiring must comply with your local/state/National Electrical Codes. A voltage variation of +/-10% of nameplate voltage is acceptable.

Environmental Limits

This equipment is designed for indoor installation only.

Sheltered locations such as attics, garages, etc., will not provide sufficient protection against extremes in temperature and/or humidity, and equipment performance, reliability, and service life may be adversely affected.

NOTICE

Altitude Limits: Maximum applied altitude not to exceed 3,000 m/9,843 ft.

NOTICE

The maximum water temperature is 120°F (49°C) and the minimum brine temperature is 25°F (-4°C). The maximum water pressure is 500 psi (3,447 kPa) through the coaxial coil and the minimum water pressure is 0 psi (0 kPa).

Initial Unit Start-Up Temperature Range

NOTICE

This is not for continuous operation. It is assumed that such a start-up is for the purpose of bringing the building space up to occupancy temperature.

Standard range units

Units are designed to start in an ambient of 50°F (10°C), with entering air at 50°F (10°C), with entering water at 70°F (21°C), with both air and water at the flow rates used in the ISO 13256-1 rating test, for initial start-up in winter.

Extended range units

Extended range heat pump conditioners are designed to start in an ambient of 40°F (4°C), with entering air at 40°F (4°C), with entering water at 40°F (4°C), with both air and water at the flow rates used in the ISO 13256-1 rating test, for initial start-up in winter.

Table 25: Air Limits in °F (°C)

Air Limits	Standard Range Units		Extended Range (Geothermal) Units	
	Cooling (DB/WB)	Heating	Cooling (DB/WB)	Heating
Minimum Ambient Air ¹	50°F (10°C)	50°F (10°C)	40°F (4°C)	40°F (4°C)
Maximum Ambient Air ²	100°F/77°F (38°C/25°C)	85°F (29°C)	100°F/77°F (38°C/25°C)	85°F (29°C)
Minimum Entering Air ¹	65°F/55°F (18°C/13°C)	50°F (10°C)	65°F/55°F (18°C/13°C)	50°F (10°C)
Common Design Entering Air	75°F/63°F (24°C/17°C)	70°F (21°C)	75°F/63°F (24°C/17°C)	70°F (21°C)
Maximum Entering Air ²	85°F/71°F (29°C/22°C)	80°F (27°C)	85°F/71°F (29°C/22°C)	80°F (27°C)

¹ Maximum and minimum values may not be combined. If one value is at maximum or minimum, the other conditions may not exceed the normal condition for standard units. Extended range units may combine any two maximum conditions, but not more than two, with all other conditions being normal conditions.

² This is not for continuous operation. It is assumed that such a start-up is for the purpose of bringing the building space up to occupancy temperature.

Table 26: Fluid Limits

Fluid Limits	Standard Range Units		Extended Range (Geothermal) Units	
	Cooling	Heating	Cooling	Heating
Minimum Entering Fluid	55°F (13°C)	55°F (13°C)	30°F (-1°C)	25°F (-4°C)
Common Design Entering Fluid	85-90°F (29-32°C)	70°F (21°C)	90°F (32°C)	35-60°F (1.5-16°C)
Maximum Entering Fluid	120°F (49°C)	90°F (32°C)	120°F (49°C)	90°F (32°C)
Minimum GPM/Ton	2.0			
Nominal GPM/Ton	3.0			
Maximum GPM/Ton	4.0			

Antifreeze

CAUTION

Do not use an automotive-grade antifreeze. Industrial grade glycols must be used. Automotive antifreeze contains inhibitors which will cause plating on the copper components used with the unit. The type and handling of glycol used must be consistent with local codes.

Glycols and other alcohols are commonly used as antifreeze; however higher percentage mixtures of alcohols such as ethanol and methanol are not recommended due to increased flammability. Your local sales office should be consulted to determine the antifreeze best suited to your area. The use of antifreeze may impact system performance depending on its concentration and should be considered during initial system design. When antifreeze is added to the water system for freeze protection, recognize that the refrigerant suction pressure will be lower, capacity will be less, and water side pressure drop will be higher. The reduction in performance depends upon the antifreeze concentration and temperature.

In areas where minimum entering loop temperatures drop below 50°F (10°C) or where piping will be routed through areas subject to freezing, antifreeze is required. If 3 GPM/ton is maintained, this limit can be lowered to 42°F (6°C). Care must be given to maintain proper water flow.

Freeze protection should be maintained to 15°F (9°C) below the lowest expected entering loop temperature. For example, if 30°F (-1°C) is the minimum expected entering loop temperature, the leaving loop temperature would be 22 to 25°F (-6 to -4°C) and freeze protection should be at 15°F (-10°C). Calculation is as follows: 30°F - 15°F = 15°F (-1°C - 9°C = -10°C).

All alcohols should be premixed and pumped from a reservoir outside of the building when possible or introduced under the water level to prevent fumes. Calculate the total volume of fluid in the piping system. Then use the percentage by volume shown in Table 27 for the amount of antifreeze needed. Antifreeze concentration should be checked from a well mixed sample using a hydrometer to measure specific gravity.

Table 27: Antifreeze Percentage by Volume

Type	Minimum Temperature for Low Temperature Protection			
	10°F (-12.2°C)	15°F (-9.4°C)	20°F (-6.7°C)	25°F (-3.9°C)
Propylene Glycol	38%	25%	22%	15%
Ethanol ¹	29%	25%	20%	14%
Methanol	25%	21%	16%	10%

¹ Must not be denatured with any petroleum product.

Table 28: Antifreeze Correction Factors

Ethylene Glycol					
	10%	20%	30%	40%	50%
Cooling Capacity	0.995	0.992	0.987	0.983	0.979
Heating Capacity	0.991	0.982	0.977	0.969	0.961
Pressure Drop	1.07	1.13	1.18	1.26	1.28
Propylene Glycol					
	10%	20%	30%	40%	50%
Cooling Capacity	0.99	0.98	0.97	0.96	0.95
Heating Capacity	0.987	0.975	0.962	0.942	0.93
Pressure Drop	1.07	1.15	1.25	1.37	1.42
Ethanol					
	10%	20%	30%	40%	50%
Cooling Capacity	0.991	0.951	–	–	–
Heating Capacity	0.995	0.96	–	–	–
Pressure Drop	1.035	0.96	–	–	–
Methanol					
	10%	20%	30%	40%	50%
Cooling Capacity	0.998	0.972	–	–	–
Heating Capacity	0.995	0.97	–	–	–
Pressure Drop	1.023	1.057	–	–	–

NOTE: Higher percentage mixtures of ethanol and methanol are not recommended due to increased flammability.

Unit Location

The console water source heat pump is typically installed on an exterior wall in the conditioned space. Locate the console unit to allow for easy removal of the filter and access panels. Allow a minimum of 18 in (46 cm) clearance on each side of the unit for service and maintenance access. The unit should be positioned to allow a minimum distance of 15 in (38 cm) from the front panel to objects in the room.

To reduce noise emissions, install a field-provided 0.25 in (6 mm) thick, rubber isolator pad below the entire base of the unit. The pad should be equal to the overall foot-print size of the unit to provide sound dampening of the unit while in operation. The unit must sit flat on the floor to prevent unwanted noise and vibration.

Piping

The console water source heat pump unit is typically connected to the supply / return piping using a “reverse return” piping configuration so that flow requirements are met for each zone. A reverse return system is inherently self-balancing and requires only trim balancing where multiple quantities of units with different flow and pressure drop characteristics are connected to the same loop. Short lengths of high pressure flexible hoses are typically used to connect the unit supply / return piping to the building’s hard piping and act as a sound attenuator for both the unit operating noise and hydronic pumping noise. Be certain that one end of the hose has a swivel fitting to facilitate removal of the unit for replacement or service. Include supply and return shutoff valves in the design to allow removal of a unit without the need to shut down the entire heat pump system. The return valve may be used for balancing and will typically have a “memory stop” so that it can be reopened to the proper position for the required flow. Fixed flow devices are commercially available and can be installed to eliminate the need for memory stop shut off valves. Include Pressure / Temperature ports to allow the service technician to measure water flow and unit operation.

Condensate drain

Each unit is supplied with a ¾” (19 mm) I.D. clear vinyl condensate hose internally trapped within the chassis. The hose extends 3½” (89 mm) outside the chassis within the piping compartment to reach the floor or the back wall. No point of the drain system may be above the drain pan of any unit.

Field condensate piping must enter within the confines of the cabinet (back wall or floor) similar to the supply and return piping. Slide the vinyl hose over the condensate pipe and secure with a hose clamp or similar method to make a water tight connection to prevent leaks. A means of disconnection must be furnished to facilitate chassis removal.

System Applications

Water source heat pump systems are one of the most efficient, environmentally friendly systems available for heating and cooling buildings. High-efficiency, self contained units (sizes 7,000 Btu/h to 300,000 Btu/h) can be placed in virtually any location within a building. Each unit responds only to the heating or cooling load of the individual zone it serves. This permits an excellent comfort level for occupants, better control of energy use for building owners and lower seasonal operating costs. The Air-Conditioning Refrigeration Institute (ARI) and the International Standards Organization (ISO) publish standards so that water source heat pumps are rated for specific applications. The ARI/ISO loop options shown in this catalog are typical water source heat pump loop choices available in today's market. These systems offer benefits ranging from low cost installation to the highest energy efficiency available in the market today.

Boiler / Tower Applications: ISO 13256-1

A "Boiler/Tower" application uses a simple two-pipe water circulating system that adds heat, removes heat or transfers rejected heat to other units throughout the building. The water temperature for heating is generally maintained between 65°F and 70°F (18°C and 21°C) and is usually provided by a natural gas or electric boiler located in a mechanical room. The condensing water temperature, during cooling months, is maintained between 85°F and 95°F (29°C and 35°C) and requires the use of a cooling tower to dissipate waste heat. Cooling towers can be located on the roof, or inside or adjacent to the building. This application can be the lowest cost of the loop options available.

NOTICE

ASHRAE 90.1 standards require that circulating pumps over 10 HP will require use of "variable frequency drive" equipment and pipe insulation to be used whenever water temperatures are below 60°F (16°C) and above 105°F (41°C). See ASHRAE 90.1 Standards for details.

Figure 40: Boiler/Tower Application

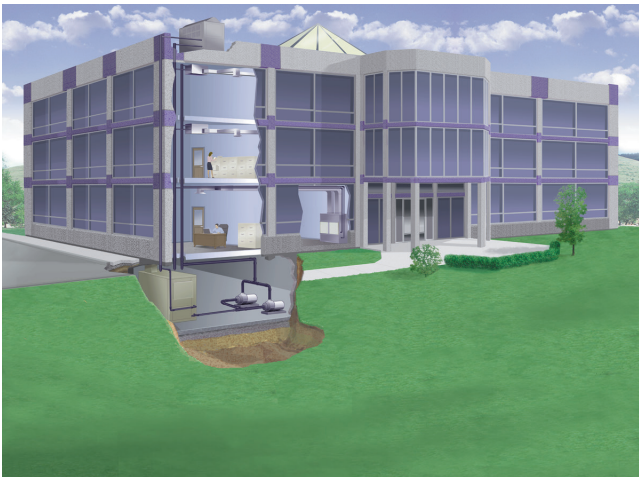

Open Loop Well Water Applications: ISO 13256-1

"Open Loop" well water systems use ground water to remove or add heat to the interior water loop. The key benefit of an open loop system is the constant water temperature, usually 50°F to 60°F (10°C to 16°C), which provides efficient operation at a low first cost. Most commercial designers incorporate a heat exchanger to isolate the building loop from the well water. Using heat exchangers can reduce maintenance issues while still allowing the transfer of heat from unit to unit as with the "Boiler/Tower System". A successful design provides an ample amount of groundwater (approximately 2 GPM per ton) and adequate provisions for discharging water back to the aquifer or surface. Open Loop applications are commonly used in coastal areas where soil characteristics allow reinjection wells to return the water back to the aquifer. Note that some states have requirements on the depths of return water reinjection wells, and such wells must be approved by the United States Environmental Protection Agency. Also, bad water quality can increase problems with heat exchanger scaling. Suspended solids can erode the heat exchanger. Strainers can be used to contain suspended solids.

Figure 41: Open Loop Well Application

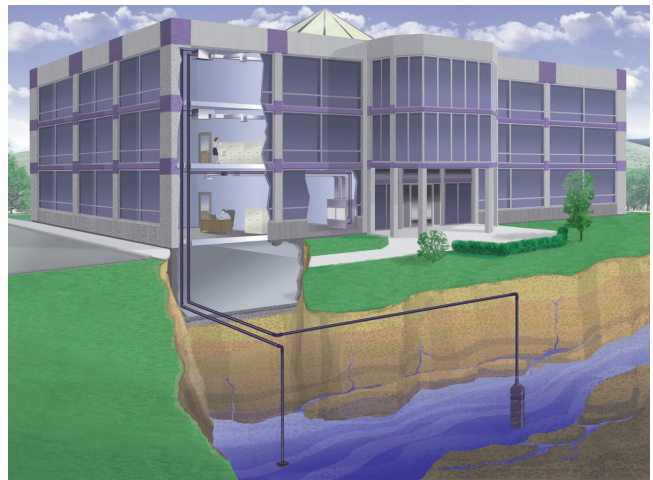

Closed Loop Geothermal Applications: ISO 13256-1

"Vertical Closed Loop" applications are installed by drilling vertical bore holes into the earth and inserting a plastic polyethylene supply/return pipe into the holes. The vertical wells are connected in parallel reverse return fashion to allow the water from the building to circulate evenly throughout the bore field. The circulating fluid dissipates heat to the ground in a similar manner as a "tower" and adds heat back to the loop like a boiler. If properly designed, the loop field can maintain the loop temperatures necessary to condition the building without the use of a boiler or a tower. Loop temperatures usually range from 37°F to 95°F (3°C to 35°C) in Northern climates.

Southern applications can see temperatures ranging from 40°F to 100°F (4°C to 38°C). The number of bore holes and their depth should be determined by using commercial software that is specifically designed for vertical geothermal applications. Typical bore depths of a vertical loop range from 150 to 400 feet (46 m to 122 m) and generally require about 250 feet (76 m) of surface area per ton of cooling.

Figure 42: Vertical Loop Application

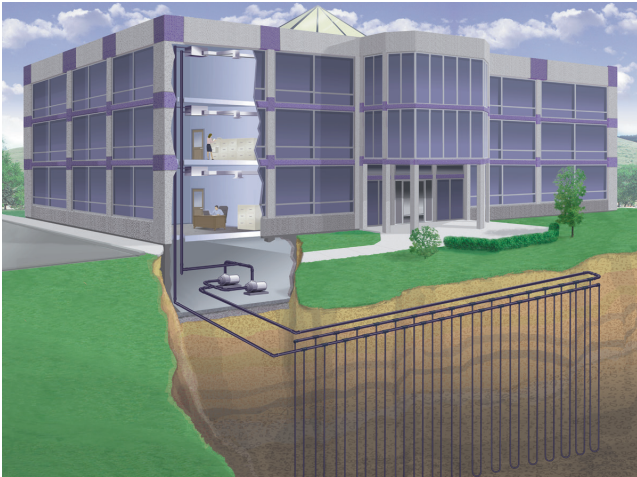

A closed loop “Horizontal” geothermal application is similar to a vertical loop application with the exception that the loops are installed in trenches approximately 5 ft (2 m) below the ground surface. The piping may be installed using a “four-pipe” or “six-pipe” design and could require 1,500 to 2,000 ft² (139 m² to 186 m²) of surface area per ton of cooling. Loop temperatures for a commercial application can range from 35°F to 95°F (2°C to 35°C) in Northern climates. Southern climates can see temperatures ranging from 40°F to 100°F (4°C to 38°C). Horizontal loops are generally not applied in urban areas because land use and costs can be prohibitive. New advances in installation procedures have improved the assembly time of horizontal loops while keeping the first cost lower than a vertical loop.

Figure 43: Horizontal Loop Application

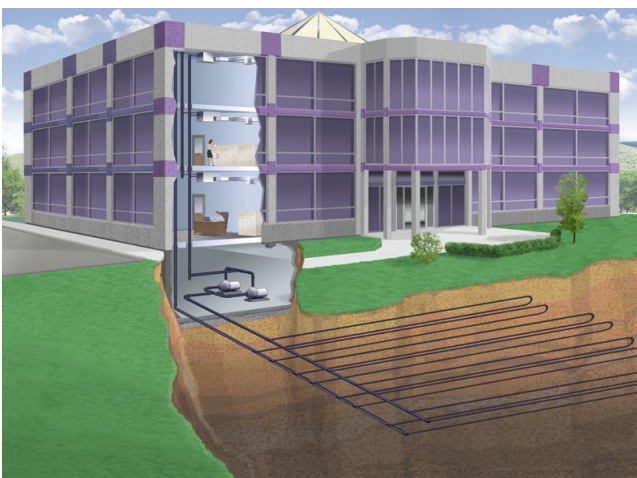

A “Surface Water” or “Lake” closed loop system is a geothermal loop that is directly installed in a lake or body of water that is near the building. In many cases, the body of water is constructed on the building site to meet drainage or aesthetic requirements. Surface loops use bundled polyethylene coils that are connected in the same manner as a vertical or horizontal loop using a parallel reverse return design. The size and the depth of the lake is critical. Commercial design services should be used to certify that a given body of water is sufficient to withstand the building loads. Loop temperatures usually range from 35°F to 90°F (2°C to 32°C) and prove to be the best cooling performer and lowest cost loop option of the three geothermal loops. Some applications may not be good candidates due to public access or debris problems from flooding.

Figure 44: Surface Water Loop Application

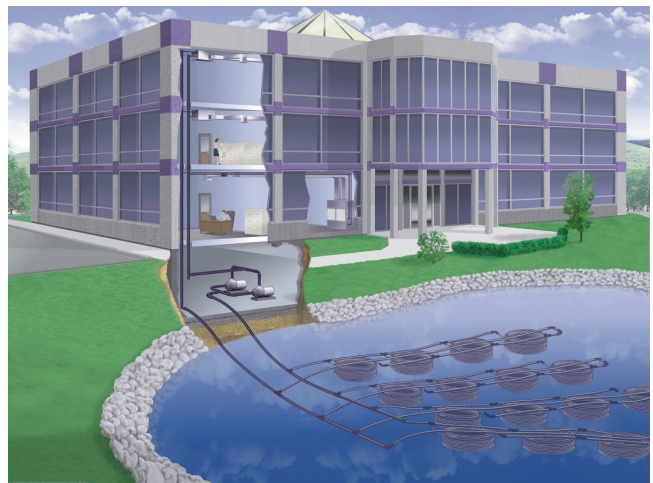

Selection Procedure

Unit Selection

Achieving optimal performance with water source heat pump systems requires both accurate system design and proper equipment selection. Use a building load program to determine the heating and cooling loads of each zone prior to making equipment selections. With this information, the Daikin Select Tools software selection program for Water Source Heat Pumps can be used to provide fast, accurate and complete selections of all Daikin Applied water source heat pump products. Select Tools software is available by contacting your local Daikin Applied Representative.

While we recommend that you use Daikin Select Tools software for all unit selections, manual selections can be accomplished using the same zone load information and the capacity tables available in this catalog.

The following example illustrates a typical selection for a zone in a boiler/tower system for a commercial building.

A building load program determines that this zone needs 10,430 Btu/h of total cooling, 6,950 Btu/h of sensible cooling and 9,150 Btu/h of total heating. The water temperatures for the boiler/tower system are 90°F for cooling and 70°F for heating. The return air temperature is 80°F dry bulb with 67°F wet bulb for cooling and 70°F for heating.

Zone requirements:

Total Cooling Load	=	10,430 Btu/h
Sensible Cooling Load	=	6,950 Btu/h
Total Heating Load	=	9,150 Btu/h
Air Flow Required	=	365 CFM
Return Air Cooling	=	80°F DB / 67°F WB
Return Air - Heating	=	70°F DB

Since a Daikin Applied Model WSRC 009 produces approximately 9,000 Btu/h of cooling, it is not sufficient for this zone and a model WSRC 012 should be considered. Typical water flow rates for boiler/tower applications are 2.0 to 2.5 GPM per ton and in this example no antifreeze is used.

Selection:

Model WSRC 012 (boiler/tower)		
Total Cooling Capacity @ 90 EWT	=	10,786 Btu/h
Sensible cooling capacity @ 90 EWT	=	7,486 Btu/h
Total Heating Capacity @ 70 EWT	=	13,903 Btu/h
Air Flow	=	365 CFM
Water Flow required to meet capacity	=	2.5 GPM
Water Pressure drop	=	7.9 (ft H ₂ O)

Final selection: WSRC 012

Engineering Specifications

SMARTSOURCE® CONSOLE WATER SOURCE HEAT PUMP

PART 1--GENERAL

1.01 WORK INCLUDED

A. The contractor shall furnish and install where shown on the plans, packaged water source heat pumps. Sizes, types and performance shall be as indicated in the unit schedule. Each unit shall be complete with factory furnished components and accessories as shown in the plans and as herein specified.

B. Provide labor, materials, equipment and services to perform operations required for the complete installation and related work as required in contract documents.

C. Electrical work required as an integral part of the temperature control work is indicated on the mechanical drawings and is the responsibility of this contractor to provide the complete system to perform the full sequence of operation shown, or as described in this specification.

1.02 SUBSTITUTIONS

A. This is a performance specification, which uses the first named manufacturer's equipment as basis of design. Other manufacturers are named as acceptable, providing the other named manufacturers comply fully with all construction details, scheduled performance requirements and the full scope of these specifications. This does not necessarily mean that the other named manufacturers equipment will fit the available space or design requirements. It shall be the responsibility of this contractor to be sure that the system provided fully meets or exceeds the specified requirements and should any changes or additional apparatus be required for other named manufacturers, this contractor shall be fully responsible for the material and installation cost (including claims by all other trades, which may be effected by the substitution), to complete the installation and comply fully with the systems as outlined in these plans and specifications. A request for a substitution shall constitute a representation that the contractor will:

1. Investigate the proposed product and determine that it is equal to or superior in all respects to that specified.
2. Provide the same warranties or bonds for the substitution as for the product specified.
3. Coordinate the installation of an accepted substitution in the work and make such other changes in the work as may be required for installation to make the work complete and equal to the basis of design in all respects.

B. Any manufacturer not named in these specifications shall be submitted to the engineer for technical review not less than fourteen days prior to the published bid date. The

solicitation for consideration of alternate manufacturers shall include, but not limited to, full submittal data on unit construction, performance, and shall include:

1. Drawings and samples to demonstrate the products compliance.
2. Outline any changes required in other elements of the work because of the substitution.
3. Availability of local service and source replacement material and parts.
4. A comparison of the proposed manufacturer's equipment with that specified. A complete copy of these specifications, with a notation written in the right margin of the specification; "C" for full compliance, or "D" for deviation, for each specification line item. For every instance of deviation, a full explanation shall be attached and identified by specification number.
5. A list of local installations where equipment of like and kind have been installed, with names and telephone numbers of personnel for each installation, who may be contacted as references.

C. The engineer shall determine compliance with the specification and whether or not the proposed manufacturer's equipment is acceptable for bid submission. Any deviation from this procedure is not acceptable and shall disqualify the proposed manufacturer. Acceptance and approval of any proposed equipment by the engineer for bid submission shall not be interpreted to imply that the proposed equipment will fit the available space or the dimensional or design requirements. The engineer will review requests for substitutions with reasonable promptness, and the decision to accept or reject the requested substitution will be responded to only by addendum. The engineer may request additional information, which must be provided and reviewed before determining compliance. If the engineer finds the product to be of general acceptance, an addendum will be issued adding that manufacturer's name. If not added by addendum, that manufacturer's equipment will not be allowed or considered for the project if submitted.

D. The judgment of the engineer shall be final.

1.03 SUBMITTALS

- A. Shop drawings including weights, dimensions, and required clearances for service.
- B. Electrical data, including minimum circuit ampacity and maximum overcurrent protection required, time delay fuse type or HACR circuit breaker required.
- C. Computer generated performance data at project application conditions.
- D. Installation details.

1.04 QUALITY ASSURANCE

A. Heat pump performance shall be certified in accordance with ARI/ISO Standard 13256-1 and shall have the correct ARI/ISO and CUL labels affixed to the

chassis. Heat pump performance at scheduled project operating conditions shall be substantiated by computer generated output data.

B. Heat pumps shall be listed by a nationally recognized safety-testing laboratory or agency, such as Underwriters Laboratory (UL), or Electrical Testing Laboratory (ETL), or Canadian Standards Association (CSA).

PART 2--PRODUCTS

2.01 GENERAL

A. Electrical – All Water Source Heat Pump units shall be suitable for continuous operation with a supply voltage variation, measured at the factory power connection point, of +/- 10% of the nameplate voltage. A control box shall be located within the unit and shall contain controls for standard components such as compressor, reversing valve, electric heat coil, and fan motor operation and shall have a 50VA 24V control circuit transformer and a terminal block for low voltage field wiring connections. Unit shall be nameplated to accept time delay fuses or HACR circuit breaker for branch overcurrent protection of the power source. All heat pump nameplate electrical utilization voltages shall be in conformance with ANSI Standard C84.1 as follows:

Nameplate Voltage	Phase	Distribution Voltage	Service, No. of Conductors
115	1	120	2
208	1	208	2
230	1	240	2
265	1	277	2

B. Cabinet – Unit exterior cabinetry shall be broken down into three separate panels (front panel and side panels) and shall be constructed of 16-gauge galvanized steel, pre-painted with Cupola White, Off White, Putty Beige, Soft Gray or Antique Ivory color. Access panels with direct contact with conditioned air shall be lined internally with acoustic type dual density fibrous glass insulation or fiber-free, cellular type insulation. Fiberglass insulation shall have edges sealed or tucked under flanges to prevent glass fibers from entering the supply air stream. All construction shall meet the National Fire Protection Association Standard NFPA 90A. Unit sub-base shall be constructed of pre-painted 16-gauge steel and have a built-in filter track for easy filter replacement from the front of the unit. Unit shall have a 2", 4" or 6" insulated rear cabinet extension with matching paint color.

C. Chassis – Each console unit shall incorporate a hinged controls enclosure for easy access to water piping or service valves. All sections of the blower housing shall be insulated with fiberglass or cellular type insulation to help reduce noise and minimize heat transfer. The compressor shall be totally enclosed within a sheet metal compartment and shall be insulated with fiberglass or cellular type insulation to minimize noise due to vibration from the compressor. The compressor must be mounted on a mass

plate system consisting of a heavy gauge steel plate and visco-elastic material to reduce noise due to vibration. The compressor compartment must have a removable access panel for service of the compressor and related refrigerant components. The condensate pan must be made of a material that is non-corrosive, high-density polyethylene plastic.

D. Blower Motor – A two-speed PSC blower motor shall be provided on 7,000 Btu/h through 18,000 Btu/h units. Factory motor wiring shall be set for optimum fan performance. Field wire cutting, stripping, or terminal application to conductors shall not be required for motor speed change.

E. Blower – All direct drive console units shall be top discharge, as shown on the drawings. The blower system shall be made up of a tangential fan wheel with support bearings on either end for maximum support and fan wheel stability. The direct drive fan motor shall be secured to the chassis with three screws and be easily removed for ease of service without having to disassemble any part of the fan housing. Clam-shell style blower systems shall not be accepted.

F. Refrigerant Circuit – A sealed refrigerant circuit, consisting of a high efficiency rotary compressor mounted on rubber vibration isolation grommets (spring isolators shall not be accepted), air-to-air refrigerant finned tube coil, refrigerant flow metering device (TXV), water-to-refrigerant coaxial tube type heat exchanger, high pressure safety cutout and fusible pressure relief factory-installed on the refrigerant circuit. Heat pump conditioners shall additionally contain a pilot-operated refrigerant reversing valve. The reversing valve shall be energized for heating operation. High and low side refrigerant service valves shall be provided. The refrigerant flow-metering device shall be a thermostatic expansion valve. Refrigerant will be HFC R-32 in all WSRC sizes 7,000 through 18,000 Btu/h.

G. Safety Controls – High pressure switch and low temperature safety sensor shall be wired through a latching lockout circuit to disable the unit until it is reset electrically by interrupting the power supply to the unit. Automatic reset by wall sensor switching shall not be allowed. All safety switches shall be normally closed, opening upon fault detection. Control logic dependent upon the closing of a normally open switch shall not be allowed to preclude the possibility of simple, easily corrected faults being escalated into compressor or heat exchanger failure due to loss of integrity in control wiring.

H. Cold Start-Up – Manufacturer shall guarantee heat pump units to start and operate in an ambient temperature of 40 degrees F with entering air at 40 degrees F, with entering water at 70 degrees F, with both air and water at the flow rates used in the ARI/ISO standard rating test, for initial system start-up in winter. (This is not a normal or continuous operating condition, and it is assumed that such a start-up is only for the purpose of bringing the building or space up to initial occupancy temperature.)

NOTICE

With alternate extended range operation, the water source heat pump loop piping must be specified to be insulated. Geothermal units are inherently "extended range."

I. Air Section – The air section of the unit shall be isolated from the compressor and control section with insulated chassis walls to minimize the transmission of compressor noise and to permit operational service testing with the compressor compartment cover removed.

J. Filters – All units shall be provided with a half-inch thick, throwaway type fiberglass filter installed in a factory mounted three-sided filter frame built into the sub-base and arranged for front removal.

K. Supply and Return, Condenser Water Connections – shall be straight, non-belled copper pipe to allow brazing of hose kits or service valves by an experienced installer. Plastic condensate drain tube shall not be less than $\frac{3}{4}$ " ID, clear plastic with formed trap to prevent gas from coming up through the condensate pan and entering the air stream. Supply, return, and condensate drain shall be connected to loop and drain piping as detail on mechanical drawings.

L. Plastic Condensate Pan – Units shall be standard with a high-density polyethylene plastic, quad-sloped drain pan. Metal drain pans are not acceptable. Condensate drain tubing shall have a formed, internal trap. Drain pan shall be easily removed from the chassis for cleaning or replacement.

M. Control System (MicroTech Unit Controller)

1. The unit control board shall be the main component of the system and shall contain the required inputs/outputs to operate a water source heat pump with a single speed fan.
2. Binary Outputs: 7 total (Main Fan, Compressor, Reversing Valve, Isolation valve/Pump Request, 1 Board Status LEDs, Room Sensor Status LED, Alarm output)
 - a. Main Fan Switched output (line or low voltage) to control single-speed fan operation.
 - b. Compressor Controls compressor operation (line or low voltage)
 - c. Reversing Valve Controls reversing valve operation via low voltage. When the reversing valve output is de-energized, the reversing valve is in the "cool" position.
 - d. Isolation Valve/Pump Request Switched output to send a signal that the water source heat pump requires loop fluid flow.
 - e. 1-tricolor onboard Status LED provides mode/ alarm indication (5 VDC).
 - f. Room Sensor Status LED provides unit status information (5 VDC).
 - g. Alarm Output will generate a 24 VAC or ground signal (depending on field wiring) signal that turns

on when the unit fan is in fault mode "A" Output 24 VAC signal that turns on when the unit fan is in fault mode.

N. Unit Controller Inputs/Outputs – The MicroTech unit controller will be microprocessor-based and have capabilities, performance, and memory sufficient to execute the various functions detailed in this specification. This document will not specify a type, a manufacturer, or a family of microcontrollers to be considered for use. However, at a minimum, the following features are deemed essential:

1. Analog Inputs: (Condensate Overflow, Brownout Detection, Suction-Line Temp Sensor, Timed Override Switch, Setpoint Adjust, Fan Mode – (Heat/Cool/Auto)
2. Condensate Overflow: The presence of excessive condensate in the condensate drain pan is detected by a condensate sensor, which consists of a metal terminal ring mounted just below the top of the condensate pan. The analog input dedicated to condensate sensing must be capable of detecting the conductivity of water between the ring terminal and chassis ground. The conductivity trip point is 2.5 micro-ohms.
3. Brownout Detection: This analog input will measure the 24VAC input voltage applied to the controller as a means of indirectly monitoring line voltage applied to the unit. The 24VAC input, once rectified, filtered, and fed to an appropriate voltage divider, will be applied to the analog input as a DC voltage level proportional to the input voltage. At a minimum, the measurable range will be between 70 and 120% of the corresponding unit nameplate voltage. Due to the tolerances involved with the various components associated with this approach, calibration will occur during factory test when exactly 100% nameplate voltage is applied to the unit while in cooling mode. The digitized value of the resultant DC voltage applied to the analog input during the calibration period will be saved within the controller (in non-volatile memory) and used as a reference value for subsequent operation in the field. The brownout trip and recovery levels are a function of the application software and are listed elsewhere in this specification.
4. Suction-Line Temp Sensor: Sensing element shall be equivalent to NTC Thermistor – 10K ohms @ 25°C, 0.2°C interchangeability. Advanced Thermal Products – Curve Z.

NOTICE

The Timed (Tenant) Override switch will short out the Room sensor thermistor. Sensing range shall be 0 to 158°F with a resolution of 1°F and an accuracy of +/- 1.5°F Maximum Total Error.

5. Setpoint Adjust: The setpoint adjust circuit of a remote room sensor shall consist of a 1.5K-ohm 2-wire potentiometer. The wiper of the potentiometer will be connected to the analog input. The other lead of the potentiometer is tied to analog common. The 0 – 1.5K-ohm range will be interpreted by the base controller as an offset to the current temperature Set point -5 to +5 degrees F or

a range of 55 to 95 degrees F (jumper selectable and scaled accordingly in software).

6. Fan On/Auto, Heat/Cool/Auto: The Room Sensor shall incorporate switches and fixed resistors that present different resistance values to a single analog input which correspond to the fan and operating mode functions detailed below. The room sensor is designed with specific resistance values to coincide with the software in unit control module.
7. Temperature Input: Sensing element in the MicroTech room temperature sensor is equivalent to NTC Thermistor – 10K ohms @ 25°C, 0.2°C interchangeability. Advanced Thermal Products – Curve Z.

NOTICE

The Timed (Tenant) Override switch will short out the Room sensor thermistor. Sensing range shall be 0 to 158°F with a resolution of 1°F and an accuracy of +/- 1.5°F Maximum Total Error.

8. Binary Inputs: 19 total (Low Pressure, High Pressure, Emergency Shutdown, 10-Board level jumpers, 5-thermostat, Occupied/Unoccupied) that employ the Occupied/Unoccupied control.
9. The Low-Pressure switch shall be sourced with 24VAC or DC, +/-20%. The binary input detection circuit shall be designed such that a minimum of 7mA current flows through the external contacts.
10. The High-Pressure switch shall be part of an interlock circuit that interrupts power to the on-board compressor relay coil. Since this is a low voltage safety circuit as defined by UL, the designer must apply appropriate spacing as dictated by the relevant UL standards. As part of HP switch state detection, this circuit must sense the current flowing through the on-board compressor relay coil and communicate this information to the HP binary input. The current sensing circuit (Example device: NEC/CEL PS2501-1-A opto-isolator) must be upstream of the High-Pressure switch, i.e., between the control output and the HP switch. In the unlikely event that the compressor binary output or HP current sensing circuit fails closed, the HP switch can still perform its intended safety function by opening the compressor relay coil circuit.
11. Emergency Shutdown: This binary input will detect the presence of an earth grounded signal, which is supplied by an external, remote set of contacts – such as those provided by a Condenser Loop Water Controller.
12. Unoccupied Mode: This binary input will detect the presence of an earth grounded signal, which is supplied by an external, remote set of contacts – such as those provided by a Condenser Loop Water Controller.
13. Thermostat inputs G, Y1, Y2, W1, W2, shall detect the presence of 24VAC sourced from the “R” terminal. The binary input conditioning circuitry for these inputs is designed to be compatible with conventional wall thermostats.
14. Board Level Configuration Switches:
 - Switch 1 - Normal/Test Mode

- Switch 2 - Continuous/Cycling Fan
- Switch 3 - Water/Glycol (Loop Fluid)
- Switch 4 - Freeze Fault Detection
- Switch 5 - Room Temperature Set Point Adjustment Range
- Switch 6 - Local Control Type (Thermostat or Room Sensor)
- Switch 7 - Primary Heating Source (Compressor or Other)
- Switch 8 - I/O Expansion Module (Preset or Not Required)
- Switch 9 - Application Select (Single Compressor or Two Compressors)
- Switch 10 - Fan Select (Future)

O. The I/O expansion board shall provide a means of adding I/O capability to the base controller in the form of extra analog inputs, analog output, binary inputs, and binary outputs. The primary use of the I/O expansion board is variable speed fan control, two stage compressor operation, dehumidification, waterside economizer, and one or two stage electric heat. Some configurations may also require options such as fan speed control, hot gas reheat coil control, and electric heater coil control.

1. Analog Inputs: 3-total (entering water temperature, return air temperature, space relative humidity)
 - a. Entering Water Temperature (EWT) monitors entering water temperature by means of a 10k Ohm thermistor.
 - b. Return Air Temperature (RAT) monitors return air temperature by means of a 10k Ohm thermistor.
 - c. Space Relative Humidity (RAH) monitors space relative humidity by means of a 0-10 VDC signal.
2. Analog Output: 1 total (PWM signal)
 - a. PWM Signal provides constant CFM or torque for fan operation within maximum and minimum settings as defined in the fan motor control.
3. Binary Inputs: 3 total (Heat stage three, Heat stage four, Humidistat)
 - a. Heat Stage three and four tells the MicroTech unit controller that 1st and 2nd stage electric heat are required.
 - b. Humidistat tells the MicroTech unit controller that dehumidification is required.
4. Binary Output: 6-total (Compressor High Capacity, Auxiliary Heat Stage 1, Hot Gas Reheat dehumidification, Waterside Economizer, Auxiliary Heat Stage 2, Tricolor status LED)
 - a. Compressor High Capacity 24 VAC signal that enables the compressor at full load capacity.
 - b. Auxiliary heat stage #1 24 VAC signal that enables stage #1 electric heat.
 - c. Hot Gas Reheat Dehumidification / Waterside Economizer enables the reheat solenoid on a request for dehumidification.

d. Waterside Economizer enables the 3-way diverting valve upon a call for waterside economizer depending on unit configuration.

e. Auxiliary heat stage #2 24 VAC signal that enables stage #2 electric heat.

f. 1-tricolor status LED that indicates operating conditions of the I/O expansion module as well as fan speed for variable speed fans.

g. Board Level Configuration Switches:

Switches 1-4 - Fan speed adjustment signals

Switches 5-6 - Secondary heating options

Switch 7 - Hot Gas Reheat dehumidification

Switch 8 - Water Side Economizer

Switch 9 - Single or Two Compressor Unit

Switch 10 - Single or Two Stage Compressor

P. [OPTIONAL] BACnet Communication Module – Unit shall have a microprocessor-based control system. The unit control logic shall communicate over a BACnet communications network. The BACnet communication module shall incorporate an Atmel ARM7 Thumb series MCU and be capable of supporting a full MSTP BACnet implementation. The microprocessor shall also support SPI compatible communications with the MCU of the MicroTech controller. The physical interface to a BACnet BAS network shall be through an industry standard RS-485 transceiver capable of existing on an RS-485 network of up to 64 nodes. The unit controller is factory programmed and tested with all the logic required to monitor and control heating and cooling operation. The controller sets the unit mode of operation, monitors water and air temperatures, and can communicate fault conditions via a BACnet communications network. Units outfitted with MicroTech and BACnet Communication modules include return air, discharge air and leaving water temperature sensors. Space temperature sensor options include a set-point adjustment, tenant override button, and the capability of substituting the return air sensor with a wall-mounted room temperature sensor.

1. Each communicating unit controller performs the following unit operations:
 - a. Enable heating and cooling to maintain space temperature set point at the room sensor
 - b. Enable fan and compressor operation
 - c. Monitor all safety controls
 - d. Monitor discharge and return air temperature
 - e. Monitor leaving water temperature
 - f. Relay status of all vital unit functions
 - g. Support optional control outputs
 - h. Adjust fan speed signals for each operating mode
2. Available room sensors include:
 - a. Room Sensor with LED Status indicator and timed override/reset button.

b. Room Sensor with LED status indicator, temperature setpoint adjustment slider from Cool to Warm (55° F to 95° F) or (-5° F to +5° F) and timed override/reset button.

c. Digital Adjustable Room Sensor with digital display for temperature, Occupancy, Alarm, Setpoint and Status indication. Include four button controls for Setpoint (55° F to 95° F) or (-5° F to +5° F), Occupied/Unoccupied request, and Override Reset.

d. Digital Adjustable Room Sensor with digital display for temperature, Humidity (For units with Dehumidification) Occupancy, Alarm, Setpoint and Status indication. Include six button controls for Setpoint (55° F to 95° F) or (-5° F to +5° F), System Mode, Occupied/Unoccupied request, and Override Reset.

Q. Emergency Shutdown – The controller will be in remote shutdown when the emergency shutdown contact closes to ground. Remote shutdown is provided so that when properly connected to a water loop controller or remote switch, the emergency shutdown input can be used to shut down the water source heat pump. When in remote shutdown no other thermostat or control inputs will have effect on unit operation. No faults or modes have higher priority than remote shutdown. Remote shutdown or brownout modes have the same level of priority.

1. When the unit is in remote shutdown mode the following occurs:
 - a. The compressor is immediately de-energized (minimum on timer is ignored).
 - b. The reversing valve is immediately de-energized.
 - c. The fan is immediately de-energized.
 - d. The alarm output is de-energized.
 - e. When the emergency shutdown input is opened, the unit will automatically return to normal operation.

R. Intelligent Reset – (Low pressure and Low temperature in heating only). The “Fault Retry” feature helps to minimize nuisance trips of automatic lockouts caused by low-pressure or low temperature faults. This feature automatically clears these faults the first two times they occur within a 24-hour period and triggers an automatic lockout on the 3rd fault. The retry count is reset to zero every 24 hours. The fault retry feature does not apply to a high-pressure fault – which causes an immediate lockout and requires a manual reset, or condensate overflow or brownout faults – which are self-clearing.

S. MicroTech Unit Controller and I/O Expansion Board Fault and Status LEDs – Separate board mounted tricolor LEDs.

1. Room Sensor Status LED: A 5VDC signal and shall operate as follows:

Status LED	Mode
On Continually	Occupied, Unoccupied Load Shed
On 0.5 sec, Off 5.5 sec	Unoccupied
On 5.5 sec, Off 0.5 sec	Tenant Override, Override Load Shed
On 0.1 sec, Off 0.1 sec	Alarm Condition (Condensate Overflow, Brownout, Compressor Fault)

T. Auxiliary Relay Output – When the unit is in alarm mode, a 24VAC or ground signal (depending on field wiring) switch is activated.

1. Onboard Status LED:

MT Controller Diagnostic LED	LED Activity	Type	Color	Description
	Steady ON	Fault	Red	MCU Not Programmed or Hardware Failure
	1 Flash	Fault	R-Y-G	Invalid Configuration
	2 Flash	Fault	R-Y-G	Incompatible Software
	1 Flash	Fault	R-Y	Expansion Board Communication Error
	2 Flash	Mode	G-Y	Service/Test Mode Active

MT I/O Expansion Board Diagnostic LED	LED Activity	Type	Color	Description
	Rapid Flash	Fault	Yellow	A2L Mitigation Sensor Failure (N/A on Console unit)
	1 Flash	Fault	Yellow	Compressor Low Voltage Brownout
	2 Flash	Fault	Yellow	Freeze Fault Detection
	3 Flash	Fault	Yellow	Control Temperature Sensor Failure
	4 Flash	Fault	Yellow	Entering Water Temperature Sensor Failure
	5 Flash	Fault	Yellow	Leaving Water Temperature Sensor Failure
	6 Flash	Fault	Yellow	Relative Humidity Sensor Failure
	7 Flash	Fault	Yellow	Condensate Overflow Sensor Failure
	8 Flash	Fault	Yellow	Space Temperature Sensor Failure
9 Flash	Fault	Yellow	Return Air Temperature Sensor Failure	

U. Standard Warranty – Daikin Applied shall warranty defective parts for a period of twelve (12) months from initial startup or eighteen (18) months from the date shipped by Daikin Applied, whichever occurs first. This

warranty is subject to the terms and conditions of the Daikin Applied Americas Inc. Limited Product Warranty.

V. [OPTIONAL] Extended Warranty (All extended warranties are subject to the terms and conditions of the extended warranty statement.):

1. An optional 1 or 4-Year Extended Compressor Only Parts Warranty OR
2. An optional 1 or 4-Year Extended Refrigeration Circuit Parts Warranty OR
3. An optional 1 or 4-Year Extended Complete Unit Parts Warranty

2.02 BASIS OF DESIGN

A. Model types HFC R-32 WSRC by Daikin Applied

2.03 ACCEPTABLE ALTERNATES

A. With prior approval only, submit a detailed summary listing of all variations in form, fit, or function, in addition to specified submittal data.

COMPLETE HVAC SYSTEM SOLUTIONS

SELF-CONTAINED | ROOFTOPS | COILS | CONDENSING UNITS
AIR HANDLERS | WATER-COOLED CHILLERS | AIR-COOLED CHILLERS
MODULAR CENTRAL PLANTS | CONNECTED BUILDING CONTROLS
UNIT HEATERS | FAN COILS | AIR PURIFIERS | WATER SOURCE HEAT PUMPS
VARIABLE AIR VOLUME UNITS | UNIT VENTILATORS



13600 INDUSTRIAL PARK BLVD. | MINNEAPOLIS, MN 55441
1-800-432-1342 | 763-553-5330

LEARN MORE AT
DAIKINAPPLIED.COM