

PRECISELINE[®] AIR HANDLERS

HORIZONTAL AND VERTICAL INDOOR AIR HANDLERS

Models BCHD, BCVD, BCAD, BCHE, BCHU, BCVE, BCVU, BCVL, and BCVR
600 to 10,000 CFM



Introduction	3	Field Control Wiring	43
Wall-to-Wall Innovation	3	Example Wiring Diagrams	45
Available Features	4	Physical Data Tables	54
Double-Wall Cabinet Construction	5	Component Weights	54
Mixing Box	5	Fan and Motor Data	59
Damper Actuator	5	Filter Data	61
Discharge Plenum	6	Thermal Expansion Valve (TXV)	62
Factory-Installed Valve Packages	6	Unit Selection	64
Slide-Out Fan Assembly and Coil Section	7	Dimensional Drawings	67
Energy Recovery Wheel	7	Size 006-050 Horizontal Unit Dimensions	67
Nomenclature	8	Size 006-050 Vertical Unit Dimensions	76
Options and Accessories	9	Size 060-100 Unit Dimensions	83
Electric Heat (Option)	9	System Considerations	116
Filter Options for Horizontal Units	11	Operation Limitations	116
Filter Options for Vertical Units	12	Application Considerations	119
Components	14	Horizontal Unit Mounting Isolation	127
A2L Refrigerant Detection and Mitigation	14	Vertical Unit Mounting Isolation	127
Refrigerant Guidelines	15	Access Panels and Doors	127
Minimum Room Area	15	Piping and Coils	128
Performance Data	21	Hydronic Coil Connections	128
Coil Performance Data	21	Condensate Drain Pan Traps	129
Heating Data	34	Engineering Specifications	130
Energy Recovery Wheel Performance Data	41		
Electrical Data	42		
Field Power Wiring	42		



Hazard Identification

	DANGER
Danger indicates a hazardous situation, which will result in death or serious injury if not avoided.	

	WARNING
Warning indicates a potentially hazardous situations, which can result in property damage, personal injury, or death if not avoided.	

	CAUTION
Caution indicates a potentially hazardous situations, which can result in minor injury or equipment damage if not avoided.	

NOTICE
Notice indicates practices not related to physical injury.

NOTE: Indicates important details or clarifying statements for information presented.

©2026 Daikin Applied, Minneapolis, MN. All rights reserved throughout the world. This document contains the most current product information as of this printing. Daikin Applied Americas Inc. has the right to change the information, design, and construction of the product represented within the document without prior notice. For the most up-to-date product information, please go to www.DaikinApplied.com.
 ™ MicroTech, PreciseLine, and Daikin Applied are trademarks or registered trademarks of Daikin Applied Americas Inc. The following are trademarks or registered trademarks of their respective companies: BACnet from American Society of Heating, Refrigerating and Air-Conditioning Engineers, Inc.; Echelon, LonWorks, LonMark, and LonTalk from Echelon Corporation; Modbus from Schneider Electric; and Windows from Microsoft Corporation.

Introduction

PreciseLine horizontal and vertical air handlers combine performance, versatility, and economy thanks to innovative and intentional design. The thermally-broke, double-wall cabinets allow PreciseLine units to supplement or anchor any project in the configurable/semi-custom air handler space.

Blower Coil Cabinets (Unit Sizes 006 – 020)

- 300-2,000 CFM
- Up to 3" of TSP
- Max height of 18" for plenum installation (for AVD)
- Dozens of coil configurations available

Light Air Handlers (Unit Sizes 030 – 050)

- 1,000-5,000 CFM
- Up to 5" TSP
- Forward-curved and welded aluminum airfoil plenum fans available

Configurable Air Handlers (Unit Sizes 060 – 100)

- 3,000-10,000 CFM
- Up to 5" TSP
- Low-leak dampers come standard; optional economizer, exhaust fans, and final filter

Wall-to-Wall Innovation

Each PreciseLine air handler is designed to make the most of every inch occupied in your space with no concessions on efficiency, capacity, or performance.

Thermal Integrity

- Thermally-broke, double-wall design means no metal-to-metal conduction between interior and exterior panels and prevents risk of mold/mildew
- Durable foam-injected panel walls for R-6.5 thermal resistance, structural reinforcement, and sound dampening
- Fully gasketed for complete air seal

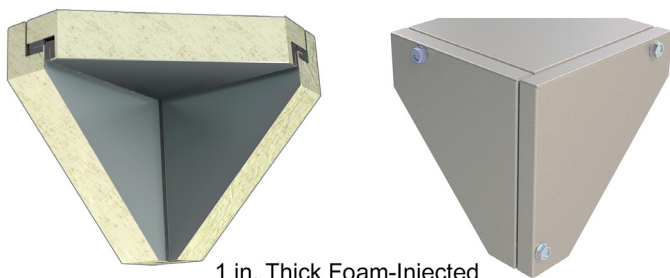

1 in. Thick Foam-Injected Cabinet Panel Insulation

No-Fuss Maintenance and Inspection

- Sheet metal interior for easy wipe-down
- Quarter-turn (toolless) panel door latches
- Slide-out rail for access to fan and coils (see [page 7](#))
- Single-side access available on vertical units

Higher Capacity, Smaller Footprint

- Foam-injected panels allow for 1" panel thickness with no compromise to thermal efficiency.
- Standard unit performance from 300 CFM to 10,000 CFM

Premium Features Available

- Mixing box with manual or modulating damper control
- High-efficiency, direct-drive EC motors
- Factory-integrated controls
- Welded aluminum airfoil plenum fans

Certifications

- Full compliance with ASHRAE 62.1-2010 for high indoor air quality
- Units are ETL and cETL listed
- Performance is AHRI 430 certified

Available Features

Table 1: Available Features Breakdown

Cabinet	UNIT SIZES		
	006-020	030-050	060-100
1" double-wall paneling with R-6.5 rating	✓	✓	✓
Powder-coated finish	✓	✓	✓
AMCA 1 damper leakage rating			✓
Mixing box with manual, On/Off, or modulating damper control (excluding vertical unit sizes 006-020)	✓	✓	✓
Economizer			✓
Discharge plenum with sound reduction package	✓	✓	✓
2" or 4" filters available in MERV 4, 8, or 13	✓	✓	✓
Final filter			✓
Energy Recovery Wheel (vertical units only)			✓
Fans and Motor	006-020	030-050	060-100
Premium efficiency direct drive EC motors	✓	✓	✓
Single-phase power	✓		
Three-phase power		✓	✓
DWDI forward-curved supply fans	✓	✓	
Welded aluminum airfoil plenum fans		✓	✓
DWDI forward-curved exhaust fans			✓
Field-adjustable 3-speed fan control	✓		
Modulating fan control	✓	✓	✓
Capable of TSP up to 3.0" w.g.	✓	✓	✓
Capable of TSP up to 5.0" w.g.		✓	✓
Cooling	006-020	030-050	060-100
2, 4, or 6-row hydronic primary coil	✓	✓	✓
8-row hydronic primary coil		✓	✓
FPT field connections	✓		
Sweat field connections	✓	✓	✓
3-row DX and VRV cooling coils	✓	✓	✓
6-row DX cooling coils	✓	✓	✓
Factory-installed valve packages	✓		
Heating	006-020	030-050	060-100
1 or 2-row hydronic secondary heating coil (preheat or reheat)	✓	✓	✓
1-row steam secondary heating coil	✓	✓	✓
Electric heat with On/Off or SCR modulating control	✓	✓	✓
Controls	006-020	030-050	060-100
Digital-ready controls	✓	✓	✓
Factory-integrated controls	✓	✓	✓
Single-point power	✓	✓	✓



**Sizes 006-020
(Vertical Model Shown)**



**Sizes 030-050
(Vertical Model Shown)**

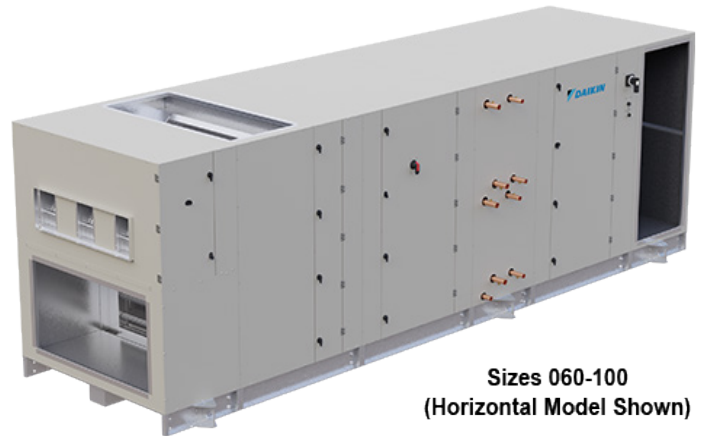

**Sizes 060-100
(Horizontal Model Shown)**

Double-Wall Cabinet Construction

Daikin Applied PreciseLine units utilize a galvanized double wall, 1-inch foam injected, thermally isolated panel. This panel construction means more thermal insulation, raising the cabinet's thermal resistance to R-6.5. This thermal resistance is more effective at keeping air cold in cooling mode and hot when in heating mode. PreciseLine's thermally insulated cabinetry helps keep insulation fibers from entering the air stream, reducing the chance of pathogens in the system, providing a cleanable surface, and increased panel rigidity for long-life. Foam injected insulation conforms to ASTM C1071 (including C665, UL 181 for erosion, and 25/50 rating for flame spread/smoke developed per ASTM E-84, UL 723 and NFPA 90A.

Mixing Box

The Daikin Applied branded air handling unit can be configured with an optional factory-installed mixing box. The mixing box is perfect for economizer operation, satisfying outdoor air requirements via mixing of indoor and outdoor air. The mix box is constructed of Daikin Applied's innovative 1-inch thick foam injected, double wall panel.

NOTICE

Unit sizes 060-100 have dual actuators.

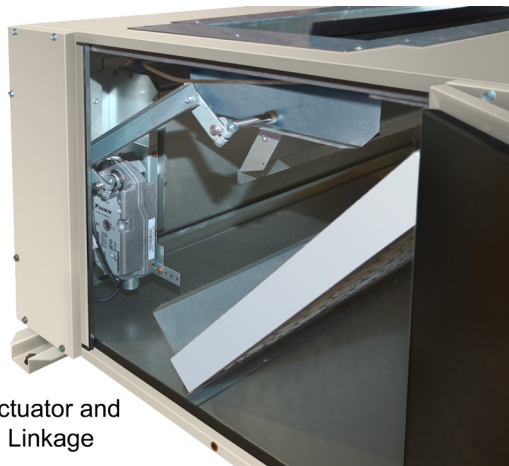

Actuator and Linkage

The mix box duct collar is flush with the cabinet and easily bends out along the perforations by the installer, reducing time and labor.



Damper Actuator

Damper actuators for mixing box control are factory-installed and wired. Control styles include 24 VAC (ON/OFF) and 0-10VDC fully modulating for economizing control. The damper actuators are spring return and field-reversible. A manual damper is also available for fixed damper applications. Coil freeze protection is the responsibility of the installing party and must be carefully considered when using this unit to condition outdoor air. Actuators listed under UL 873, CE, CSA, and C22.2.

On unit sizes 006-20, the damper actuator is located on the side opposite the coils. On unit sizes 030-100, the damper actuator is located on the same side as the coils.

Discharge Plenum

Daikin Applied offers an optional discharge plenum, factory mounted and shipped assembled on the discharge end of the main unit. The plenum is available in multiple discharge configurations. The discharge plenum can also be ordered with an industry-leading sound-attenuation package, minimizing sound amplitude and improving sound quality.

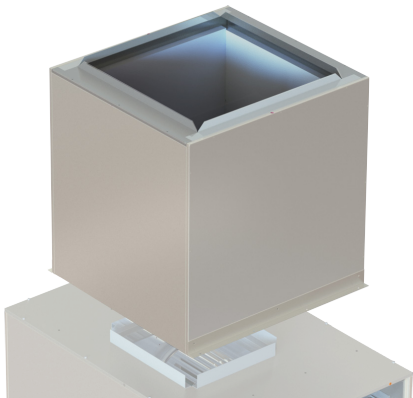
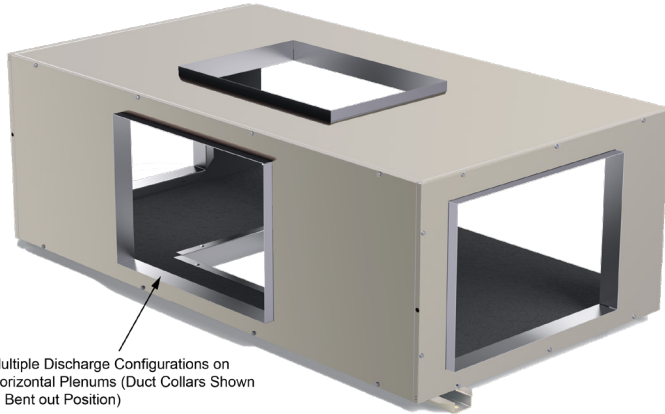

NOTE: Top Discharge Only

Factory-Installed Valve Packages

Factory valve and piping packages are available for both two-pipe and four pipe systems for unit sizes 020 and smaller. All factory assembled packages are leak tested and ship supported by an expandable foam agent. The valve packages are assembled inside the cabinet and water connections terminate outside the cabinet for quick field hook-up. Valve piping is easily accessible through a single panel, for easy service. A secondary sloped drain pan covers the span of the internal valve package making pipe insulation unnecessary for the piping package inside of the cabinet.

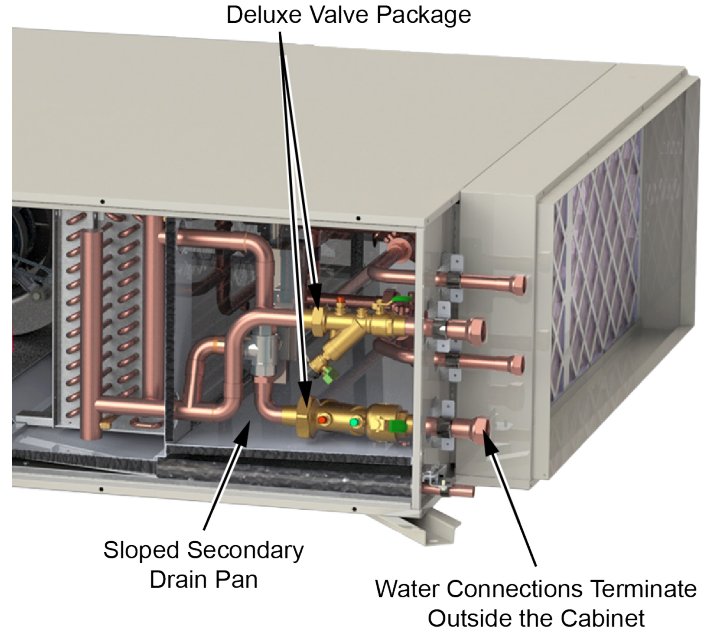

Valve packages provide added value by reducing installing contractors time. Connection points are pre-determined, allowing the building supply and return piping to be pre-installed before the arrival of the air handler.

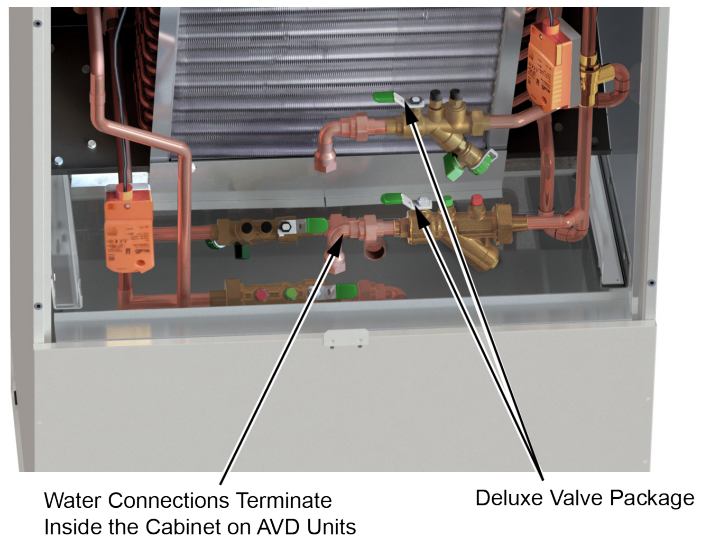

Slide-Out Fan Assembly and Coil Section

The DWDI forward-curved and plenum fans are installed on a sub-assembly that can slide out independently on a rail and track system for easy maintenance.

Motor and Fan Assembly are Easily Removed on a Rail and Track System

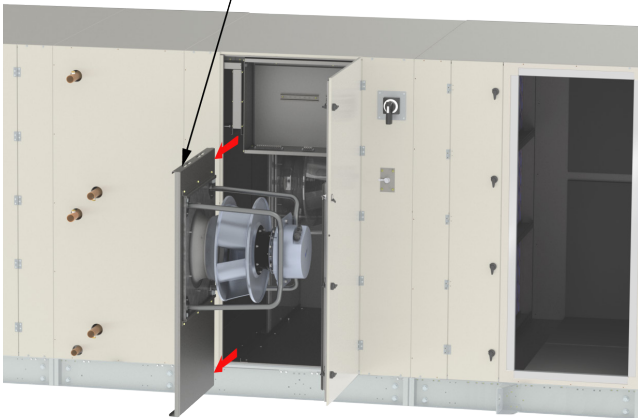

The coil section assembly slides out providing easy service and maintenance access. Valve package unions disconnect on the coil piping side, and the coil removed without disrupting the buildings supply and return water connections.

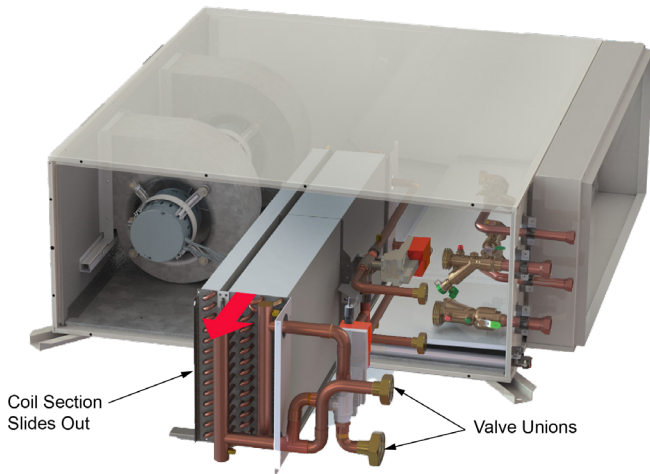

- Winter humidification energy costs may be cut up to 60%.
- Winter latent energy recovery lowers the dew point of exhaust air, compared to sensible-only alternatives, and allows frost-free operation to a lower ambient temperature.
- Optional energy recovery wheel for increase efficiency for conditioning minimum outdoor air.
- Unitary design for installation/rigging cost savings.
- Single point power connection for decreased installation cost.
- Slide-out wheel cassette & track for easy maintenance and cleaning.
- Bypass dampers for increased efficiency during economizer operation.
- Integrated unit control for control coordination between rooftop unit and wheel that controls the wheel speed.
- Leaving wheel temperature sensors for wheel operation monitoring.
- Integrated unit control with optimum leaving wheel temperature control to prevent over-heating the outdoor air.
- Defrost options including ON/OFF control, constant speed frost prevention, variable speed frost prevention, and preheat.
- MERV 8 prefilters provided on outdoor and return air paths minimize dirt and cleaning.

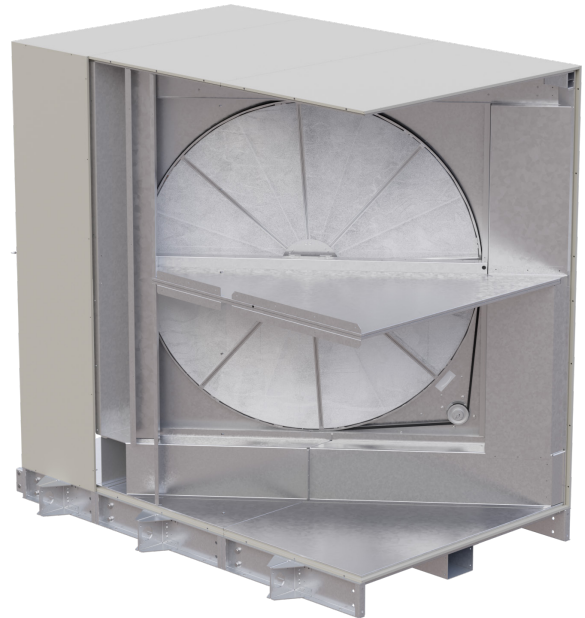

Energy Recovery Wheel

Daikin Applied energy wheels normally recover 70-75% of both sensible and latent energy. Energy recovery wheels are available for vertical unit sizes 060-100. Considerable energy savings can result:

- Provide twice as much summer energy recovery as sensible-only alternatives, such as run-around loops.
- Energy recovery can increase the air conditioning capacity by 25% if the minimum outdoor air design is 33%. The cost savings on mechanical heating and cooling components offset the additional investment of energy recovery.

Nomenclature

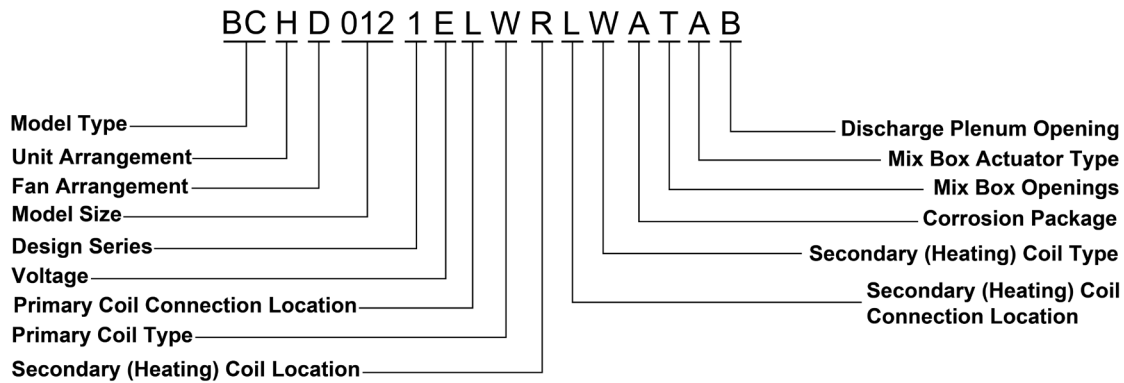

Category	Code	Description
Model Type	BC	Daikin Applied Air Handler
Unit Arrangement	H	Horizontal
	V	Vertical
	A	AVD / Compact Vertical (Unit Sizes 006-020)
Fan Arrangement	D	Draw Thru Forward-Curved Fan
	E	Draw Thru Plenum Fan, End Discharge
	U	Draw Thru Plenum Fan, Up Discharge
	R	Draw Thru Supply Fan / Direct Drive Plenum Fan, Right Side Discharge
	L	Draw Thru Supply Fan / Direct Drive Plenum Fan, Left Side Discharge
Model Size	006	Nominal 600 CFM
	008	Nominal 800 CFM
	010	Nominal 1,000 CFM
	012	Nominal 1,200 CFM
	016	Nominal 1,600 CFM
	018	Nominal 1,800 CFM
	020	Nominal 2,000 CFM
	030	Nominal 3,000 CFM
	040	Nominal 4,000 CFM
	050	Nominal 5,000 CFM
	060	Nominal 6,000 CFM
	080	Nominal 8,000 CFM
100	Nominal 10,000 CFM	
Design Series	1	1st Vintage
Voltage	A	115/60/1
	E	208/60/1
	G	460/60/1
	K	230/60/1
	P	277/60/1
	D	208/60/3
	L	230/60/3
	T	460/60/3
	W	575/60/3
Primary Coil Connection Location	L	Left Hand (Air Back of the Head)
	R	Right Hand (Air Back of the Head)
	C	Center

Category	Code	Description
Primary Coil Type	W	Chilled Water / Glycol
	D	DX / R-410A
	R	DX / R-32
	B	DX / R-454B
	V	VRV
Secondary (Heating) Coil Location	P	Preheat
	R	Reheat
	Y	None
Secondary (Heating) Coil Connection Location	L	Left Hand (Air Back of the Head)
	R	Right Hand (Air Back of the Head)
	Y	None
	C	Center
Secondary (Heating) Coil Type	W	Hot Water / Glycol
	Y	None
	S	Steam
Corrosion Package	A	(Coil Casing) Stainless / (Fin Coating) None / (Drip Pan Corrosion Pkg.) Stainless
	Y	(Coil Casing) Galvanized / (Fin Coating) None / (Drip Pan Corrosion Pkg.) Galvanized
Mix Box Openings	T	Top + Rear
	B	Bottom + Rear
	E	Economizer Top Return/End Top EA/End Bottom OA
	Y	None
Mix Box Actuator Type	T	ON/OFF
	A	0-10V Modulating
	C	On/Off Controller
	M	Manual
Discharge Plenum Opening	Y	None
	B	Bottom
	T	Top
	E	End
	Y	None - No Discharge Plenum
	R	Right Hand (Air Back of the Head)
	L	Left Hand (Air Back of the Head)
	F	Field Cut-Out (Has a Plenum)

NOTE: Not all code options shown.

Options and Accessories

Electric Heat (Option)

The optional factory-installed electric heat section consists of an open coil heater rack mounted to the units' primary coil. The heating coil is in the preheat position for horizontal units and the reheat position for vertical units. Electric heat is designed to operate only when the supply fan is running, heating the air as it passes through the heating elements. The electric heat section consists of the mounting rack, electric elements, contactor, optional SCR module and the manual and automatic reset thermal limits with multiple on-board control systems for safety. Electric heat comes pre-wired to the main control box for a single point power connection to the unit.

Available in a wide range from 1-133kW, these heating elements can be controlled with a 24 VAC ON/OFF signal, 4-stage ON/OFF signal (unit sizes 060-100), or with a 0-10VDC, fully modulating Silicone Controlled Rectifier (SCR). The SCR modulates the electric heat element which means no noisy relays clicking on and off, precise temperature control, increased thermal comfort and improved energy efficiency. Electric heat is available on 2-pipe systems only.

Unit sizes 060-100 require dual-point power for electric heat.

Post Electric Heater Accessory

Available in 15 kW-250 kW, post electric heaters can be used to supplement primary heating coils, eliminating the need to spec large hydronic coils for the infrequent off design high load days.

Figure 1: Electric Heat Section (Reheat Coil Shown)

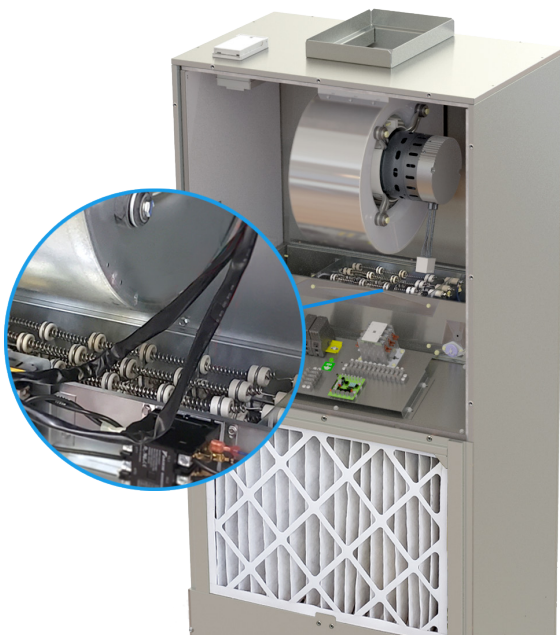

Figure 2: Electric Heat Section (Reheat Coil Shown)

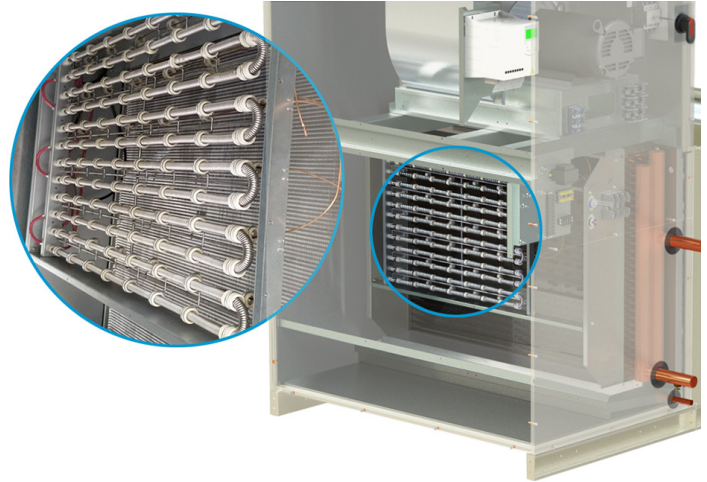

Figure 3: Electric Heat Section (Preheat Coil Shown)

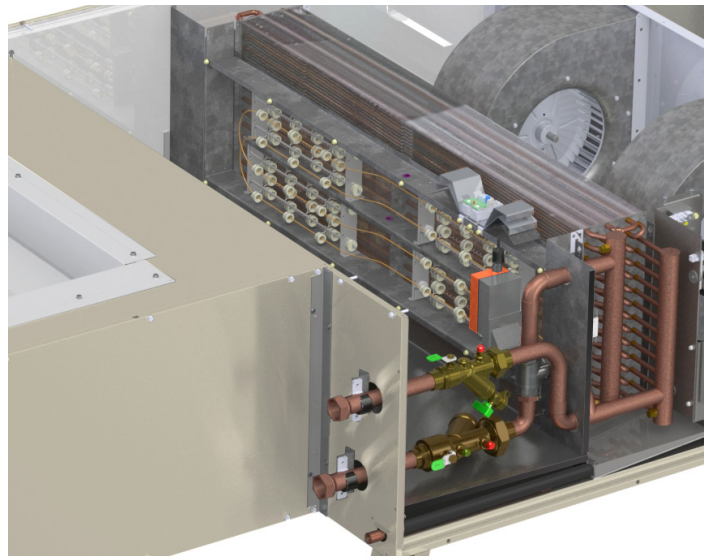
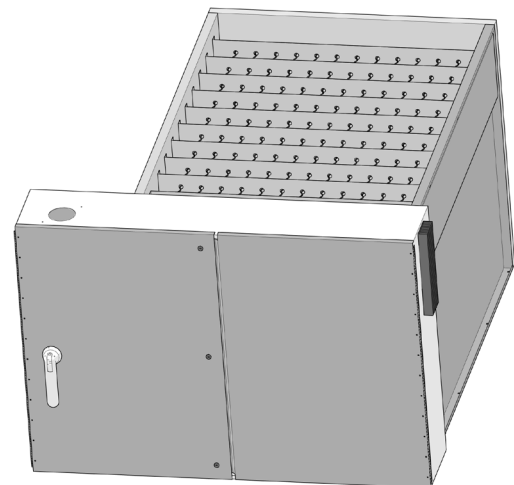
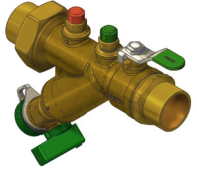
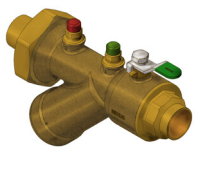

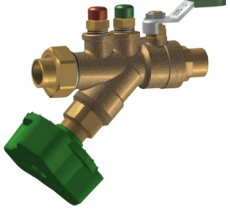









Figure 4: Post Electric Heater Accessory



Shutoff and Ball Valves			
<p>Shut-off Valve w/Y-Strainer</p> 	<p>Autoflow Shut-off Valve w/Strainer</p> 	<p>Shut-off Ball Valve</p> 	<p>Manual Circuit Setter</p> 

The deluxe factory installed piping package includes a fully modulating 0-10VDC or 24V ON/OFF control valve (2-way/3-way), a water strainer with blowout, P/T ports, unions, shut-off isolation valves, and an auto-flow circuit setter. This control scheme matched with a fully modulating fan allows for maximum space comfort and energy efficiency.

All piping packages are installed with control valves, automatic and manual circuit setters, strainers, and shut-offs. The control valve and circuit setter are located on the return side of the coil (with the exception of size 006 and 008 vertical units). The strainer is located on the supply side of the coil. Several control valve types are available.

Control Valves																													
<p>Two-Way On/Off (2-Position) Valves</p>	<p>Three-Way On/Off (2-Position) Valves</p>	<p>Two-Way Modulating Valves</p>	<p>Three-Way Fully Modulating Valves</p>																										
<p>2-Way, 0.50FPT, On/Off, 24V, NO</p> 	<p>3-Way, 0.75FPT, 24Cv, On/Off, 24V, NC</p> 	<p>2-Way, 0.50FPT, 16Cv, Modulating, 0-10VDC</p> 	<p>3-Way, 0.50FPT, 16Cv, Modulating, 0-10VDC</p> 																										
<p>2-Way, 0.75FPT, On/Off, 24V, NC</p> 	<p>3-Way, .050FPT, On/Off, 24V, *Adjustable to NO or NC</p> 	<p>Two-way modulating valves allow for finely-tuned water flow which improves space comfort control as well as energy management. Modulating valves respond to a 0-10VDC signal from your thermostat or terminal controller. The valve body operates as an equal-percentage flow type. A method of relieving pump head pressure should be employed when selecting two-way valves.</p>	<p>Three-way modulating valves allow for finely-tuned water flow which improves space comfort control as well as energy management. Modulating valves respond to a 0-10VDC signal from your thermostat or terminal controller. The valve body operates as an equal-percentage flow type. A method of relieving pump head pressure should be employed when selecting three-way valves.</p>																										
<p>2-Way, 0.50FPT, On/Off, 24V, *Adjustable to NO or NC</p> 	<p>These valves will either be in a fully OPEN or fully CLOSED state in response to a 24 VAC signal from the controller. Normally Closed or Normally Open are available, both are of spring-return type. Three way valves are of the mixing type.</p>	<p>Selecting Correct Valve Characteristics</p> <p>Daikin Select Tools™ is automatically configured to match the valve body size to the selected coil. Valve Cv can be automatically selected based on the pressure drop through the coil and required GPM or user selected for more versatility.</p>																											
<p>These valves will either be in a fully OPEN or fully CLOSED state in response to a 24 VAC signal from the controller. Normally Closed or Normally Open are available, both are of spring-return type. A method of relieving pump head pressure should be employed when selecting two-way valves.</p>	<p>Valves (vertical unit sizes 006 and 008) can be field-adjusted to be normally open or normally closed. By adjusting the manual clip, Cv values for the valve can be altered.</p> <table border="1"> <thead> <tr> <th rowspan="2">Size</th> <th colspan="8">Clip Position for Cv Adjustment (2-Way Valves)</th> </tr> <tr> <th>1</th> <th>2</th> <th>3</th> <th>4</th> <th>5</th> <th>6</th> <th>N</th> <th>No Clip</th> </tr> </thead> <tbody> <tr> <td>1/2"</td> <td>0.5</td> <td>0.7</td> <td>1.2</td> <td>1.7</td> <td>2.4</td> <td>3.4</td> <td>4.8</td> <td>5.9</td> </tr> </tbody> </table>			Size	Clip Position for Cv Adjustment (2-Way Valves)								1	2	3	4	5	6	N	No Clip	1/2"	0.5	0.7	1.2	1.7	2.4	3.4	4.8	5.9
Size	Clip Position for Cv Adjustment (2-Way Valves)																												
	1	2	3	4	5	6	N	No Clip																					
1/2"	0.5	0.7	1.2	1.7	2.4	3.4	4.8	5.9																					

Filter Options for Horizontal Units

Tool-less filter access on all sizes of the main unit can be ordered as side, bottom or top removal, (right or left hand). Top and bottom filter access is available on horizontal units through an easily removed sliding plate. AVD units come with side, top, or internal access to the filter. Side filter access is through the slotted end plate that removes easily from tabs along the filter frame. Units with the optional mix box have hinged access doors with tool-less 1/4-turn door latch(es) and can be ordered as side filter access (right or left hand) or bottom access (horizontal only; not available with bottom return). Filter racks are factory configurable to accept 4", 2" or 2" + 2" filter options. Merv 4, Merv 8, and Merv 13 rated filters are available from the factory. Daikin Applied's PreciseLine air handler comes standard with a 2" Merv 4 filter to prevent construction dust and debris from entering the unit upon startup, installation, and storage.

Merv Rating	Filter Depth	
	2"	4"
4	Available	—
8	Available	Available
13	Available	Available

NOTE: For filter details refer to, [Table 44 on page 61](#).

Figure 5: Unit Size 020 Bottom or Top Filter Access



Figure 6: Unit Size 020 Side Filter Access

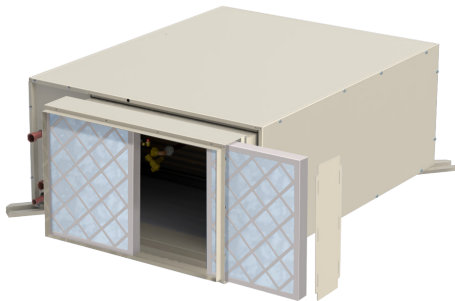

Figure 7: Unit Size 040 Bottom or Top Filter Access

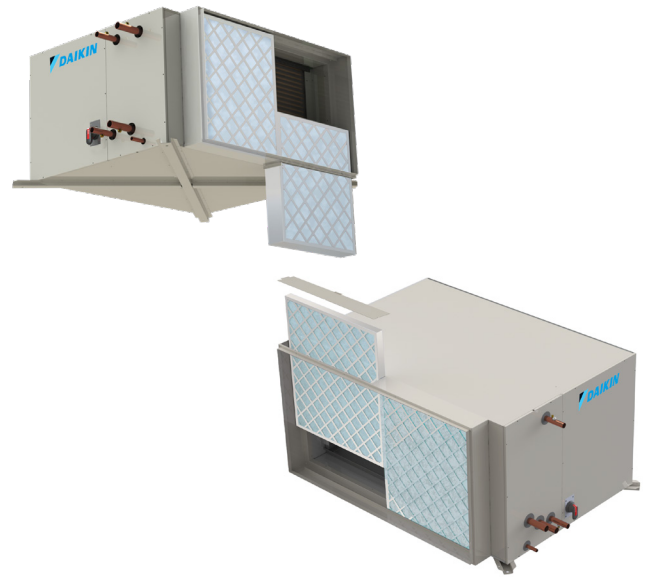

Figure 8: Unit Size 040 Side Filter Access



Figure 9: Unit Size 020 Optional Mixing Box with Side Filter Access

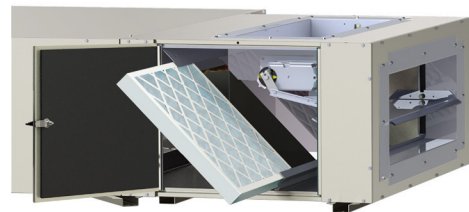

Figure 10: Optional Mixing Box Bottom Filter Access



Filter Options for Vertical Units

Note: If the unit has an internal filter and has its inlet ducted, the ducting will need to be removed to access the filter.

Toolless filter access on all sizes of the main unit can be ordered as side, bottom or top removal, (right or left hand). Top and bottom filter access is available on horizontal units through an easily removed sliding plate. AVD units come with side, top, or internal access to the filter. Side filter access is through the slotted end plate that removes easily from tabs along the filter frame. Units with the optional mix box have hinged access doors with tool-less 1/4-turn door latch(es) and can be ordered as side filter access (right or left hand) or bottom access (horizontal only; not available with bottom return). Filter racks are factory configurable to accept 4", 2" or 2" + 2" filter options. Merv 4, Merv 8, and Merv 13 rated filters are available from the factory. Daikin Applied's PreciseLine air handler comes standard with a 2" Merv 4 filter to prevent construction dust and debris from entering the unit upon startup, installation, and storage.

Merv Rating	Filter Depth	
	2"	4"
4	Available	—
8	Available	Available
13	Available	Available

NOTE: For filter details refer to, [Table 45 on page 61](#).

Figure 11: Unit Sizes 006 - 020 External Filter Removal on Left Side

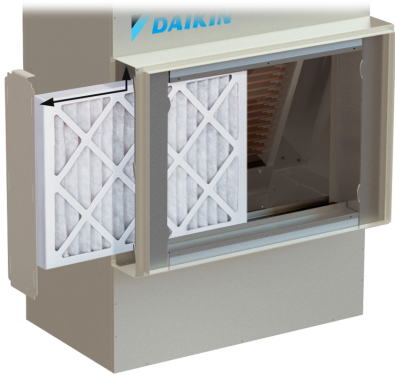

Figure 12: Unit Sizes 006 - 020 External Filter Removal on Right Side

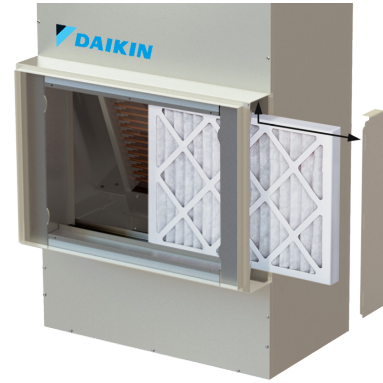

Figure 13: Unit Sizes 006 - 020 Internal Filter Removal



Figure 14: Unit Sizes 030 - 050 Filter Access



Figure 15: Unit Sizes 030 - 050 Side Filter Access



Figure 16: Unit Sizes 060-100 Post / Discharge Filter Access



Figure 17: Unit Sizes 060-100 Pre-Filter Removal



Components

A2L Refrigerant Detection and Mitigation

A2L Refrigerant Detection System

UL 60335-2-40 requires all units with refrigerant charges of 64 oz or greater per circuit to have refrigerant leak detection/mitigation. To meet this requirement, all PreciseLine units using A2L refrigerant include a factory installed refrigerant leak detection system consisting of the following parts:

- Refrigerant Sensor(s) (quantity 1)
R-32 Sensor Part Number: 910419801
R-454B Sensor Part Number: 910483696
- A2L Refrigerant Detection Controller (quantity 1)
Part Number: 910419225

The sensors are wired in a daisy chain configuration and terminated at the mitigation board. The A2L Main Control board connects to the MicroTech controller and signal alarms based on this system status. See OM 1357 for a full description of the Refrigerant Detection Controller.

Alarms

- Refrigerant Leak:
 - The Refrigerant Detection Controller will trigger a leak alarm when at least 1 sensor detects a refrigerant concentration above 15% of the refrigerant Lower Flammability Level (LFL).
 - Upon detection of a leak, the mitigation board ALM and CUST relays are energized and the alarm is indicated to the MicroTech unit controller.
- Refrigerant Sensor Fault:
 - The Refrigerant Detection Controller will trigger a fault alarm when any connected sensor is determined to be faulty (self-test failure, loss of communications, etc.).
 - Upon detection of a sensor fault, the fault is indicated to the MicroTech unit controller.

A2L Leak Mitigation

The MicroTech controller performs the following mitigation sequences to maintain safe operation in the event of an alarm condition:

Refrigerant Leak Detected

Upon notification from the refrigerant detection system that a leak was detected, the MicroTech controller will disable compressor operation immediately, turn the fan on at A2L mitigation speed, disable electric heat, and indicate a refrigerant leak alarm.

- The Refrigerant Detection Controller continues to monitor the refrigerant sensors in the system and notifies the MicroTech unit controller when no refrigerant has been detected for five minutes, allowing the unit to resume normal operation.

Sensor Fault Detected

A fault can be caused by a leak sensor malfunctioning or being disconnected or an A2L board malfunction.

Upon notification from the refrigerant detection system that a sensor fault was detected, the MicroTech controller will allow normal operation except that it will turn the fan on at A2L mitigation speed, to maintain adequate airflow through the system to dilute any of the leaked refrigerant, and indicate a sensor fault alarm.

A2L Refrigerant Detection Sensor and Board Service

- The sensors are not considered “Limited Life Sensors” and therefore, under normal operation, are not expected to be replaced within the life expectancy of the unit.
- The sensors have self-reporting diagnostics, which are monitored by the mitigation board. In the event that the sensor fails, the mitigation board will trigger a “Fault” alarm.
- There are no servicing nor maintenance requirements for the sensor(s) and board.

A2L Refrigerant Detection Sensor and Board Troubleshooting and Diagnostics



At power up, the Refrigerant Detection Controller display shows what sensors are detected (SX = 1, sensor X is active and communicating), and what sensors are not detected (SX = 0, sensor X is not communicating or inactive). Where X, is the sensor number (from 1 to 8).

By pressing and holding the push button for:

- *Less than 2 seconds*
The Refrigerant Detection Controller display shows the last 10 sensor faults (can be loss of communication or faulted state reported by a specific sensor). General configuration fault (Fit CFG) is also shown when the expected number of sensors does not match the number of sensors detected online.
- *More than 2 seconds and less than 5 seconds*
The display shows sensor(s) status info:
 - The current LFL level.
 - Loss of communication or faulted state reported by a specific sensor.
- *More than 5 seconds and less than 10 seconds*
The Refrigerant Detection Controller starts a mitigation test. The board will go into alarm mode and the MicroTech controller will begin the mitigation sequence. The mitigation test will last approximately 5 minutes.
- *More than 10 seconds*
The display shows all the GID values supported by the sensor board. Refer to OM 1357 for additional information.

Refrigerant Guidelines

(For Units with A2L Refrigerant)

 WARNING	
 A2L	<p>This unit contains either R-32 or R-454B refrigerant. Both are class A2L refrigerants that are flammable. This unit should only be installed, serviced, repaired, and disposed of by qualified personnel licensed or certified in their jurisdiction to work with the specific A2L refrigerant. Installation and maintenance must be done in accordance with this manual. Improper handling of this equipment can cause personal injury or equipment damage.</p>
<p>For installation only in locations not accessible to the general public.</p> <p>Be aware that R-32 and R-454B refrigerant may not contain an odor. Place in a well ventilated area to prevent accumulation of refrigerant. Excessive refrigerant leaks, in the event of an accident in a closed ambient space, can lead to oxygen deficiency.</p> <p>Do not pierce or burn this unit.</p> <p>Never use an open flame during service or repair. Never store in a room with continuously operating ignition sources (for example: open flames, an operating gas appliance, or and operating electric heater), where there is ignitable dust suspension in the air, or where volatile flammables such as thinner or gasoline are handled.</p> <p>PreciseLine units should only be connected to appliances that are suitable for the air handling unit's designated refrigerant.</p> <p>Only use pipes, nuts, and tools intended for exclusive use with the unit's designated A2L refrigerant in compliance with national codes (ASHRAE15 or IRC).</p> <p>Do not mix air or gas other than the unit's designated A2L refrigerant in the refrigerant system.</p> <p>Do not use means to accelerate the defrosting process or to clean, other than those recommended by the manufacturer.</p>	

 WARNING
<p>The appliance is designed to activate leak mitigation airflow in the event a refrigerant leak is detected. This is required to ensure dilution and prevent stagnation of any leaked refrigerant. Always ensure the supply fans are able to operate freely. Always maintain proper airflow and do not allow filters, air inlets, or air outlets to become blocked. Refer to Figure 35.</p>

 WARNING
<p>The appliance shall be installed, operated, and stored in a room with a floor area not less than the Minimum Room Area.</p>

Minimum Room Area

 WARNING
<p>Failure to maintain the required Minimum Room Area for leaked refrigerant dilution may result in property damage, serious personal injury, or death.</p>

In the unlikely event of a refrigerant leak, the leak detection system must activate the supply fans to a preset speed that corresponds to an airflow that is always greater than the

minimum required airflow rate. This airflow is required to dilute any leaked refrigerant and prevent stagnation.

The actual unit airflow may be much higher depending on the unit configuration. The minimum airflow rate is based on circuit charge quantity and is detailed in [Figure 19 on page 17](#) and [Figure 20 on page 18](#).

This unit contains an A2L refrigerant (R-32 or R-454B). The served indoor space must be larger than or equal to the Minimum Room Area as shown in [Figure 21](#) or [Figure 22](#). In the unlikely event of a refrigerant leak this room area must meet this requirement to ensure dilution and prevent stagnation of any leaked refrigerant.

The Refrigerant Charge of each unit should be determined and used to confirm the Minimum Room Area prior to installation.

Minimum Room Area Calculation (A2L Refrigerants)

 WARNING
<p>Never allow this unit to service room(s) in which the total room area does not meet the minimum room area requirement. This may lead to flammable or toxic conditions, causing equipment damage, serious personal injury, or death.</p>

- Units installed with an A2L refrigerant must be evaluated for each circuit's total charge. Total refrigerant charge is calculated by adding the DX coil, field piping, and condenser charge together for a particular circuit.
- Using the circuit with the greater total charge (if applicable), the minimum allowable room area must be calculated and recorded on the unit safety label.

NOTICE
<p>Use permanent marker that conforms to ASTM D-4236.</p>

When the appliance is connected to an unventilated space the following rules shall apply to determine if connected spaces can be used in the Minimum Room Area calculation. The room area shall be defined as the room area enclosed by the projection to the floor of the walls, partitions and doors of the space in which the unit serves. Spaces connected by only drop ceilings, ductwork, or similar connections shall not be considered a single space. Rooms on the same floor and connected by an open passageway between the spaces can be considered a single room when determining compliance to Minimum Room Area, if the passageway complies with all of the following:

- It is a permanent opening.
- It extends to the floor.
- It is intended for people to walk through.

The area of the adjacent rooms, on the same floor, connected by a permanent opening in the walls and/or doors between occupied spaces, including gaps between the wall and the floor, can be considered a single room when determining compliance to the Minimum Room Area, provided all of the following are met:

- The minimum opening area connecting the spaces/rooms shall not be less than 0.0123 m².
- The area of any openings above 300 mm from the floor shall not be considered part of the minimum opening area.

- At least 50% of the minimum opening area shall be below 200 mm from the floor.
- Openings are permanent openings which cannot be closed.
- For openings extending to the floor the height shall not be less than 20 mm above the surface of the floor covering.
- A second higher opening shall be provided. The total size of the second opening shall not be less than 50% of the minimum opening area and shall be at least 1.5 m above the floor.

NOTICE

The requirement for the second opening can be met by drop ceilings, ventilation ducts, or similar arrangements that provide an airflow path between the connected rooms.

Altitude Considerations for Minimum Room Area

When the unit is installed at altitude above sea level the minimum room area must be adjusted by the multiplier shown in Table 2. This will increase the required minimum room area of the served space.

If the actual room area served by the appliance is not large enough to meet the Minimum Room Area additional measures such as mechanical ventilation of the space may need to be employed. Please contact Daikin Applied for additional information.

Table 2: Minimum Room Area Multipliers by Altitude

Altitude (Meters)	Minimum Room Area Multiplier
0	1
305	1.047
500	1.078
750	1.117
1000	1.156
1250	1.195
1500	1.234
1750	1.273
2000	1.312
2250	1.351
2500	1.39
2750	1.429
3000	1.468
3250	1.507
3500	1.546

Refrigerant Detection System Operation

The Refrigerant Detection System (RDS) is controlled by a refrigerant sensor(s), which is secured to a designated location(s) for active monitoring. If a leak is detected, compressor and electric heat operation is disabled and the supply fan blower fan is activated, providing airflow at or above the minimum required airflow to evacuate excess concentration. Once the time is over, the unit will resume its normal operation. If the sensors detect another refrigerant concentration excess, the unit will go back into mitigation mode and will repeat the same process.

Refrigerant Detection System and Sensors

For additional instructions on how to operate the RDS including how to activate a manual test of the RDS, refer to the unit controller manual.

WARNING

This unit is equipped with a RDS. Only components and refrigerant detection sensors specified by Daikin Applied may be used for replacement and maintenance.

WARNING

Always ensure the refrigerant detection sensors installed in the equipment are free of debris and the inlet is not blocked. If replacing a refrigerant detection sensor, always install in the identical orientation as the original sensor.

Figure 18: Sample Refrigerant Detection Sensor



NOTE: Identify the sensor inlet marked “Do Not Block Inlet,” and ensure it is free of debris.

Figure 19: R-32 Refrigerant - Minimum Circulation of Airflow (Qmin)

Qmin (R32)

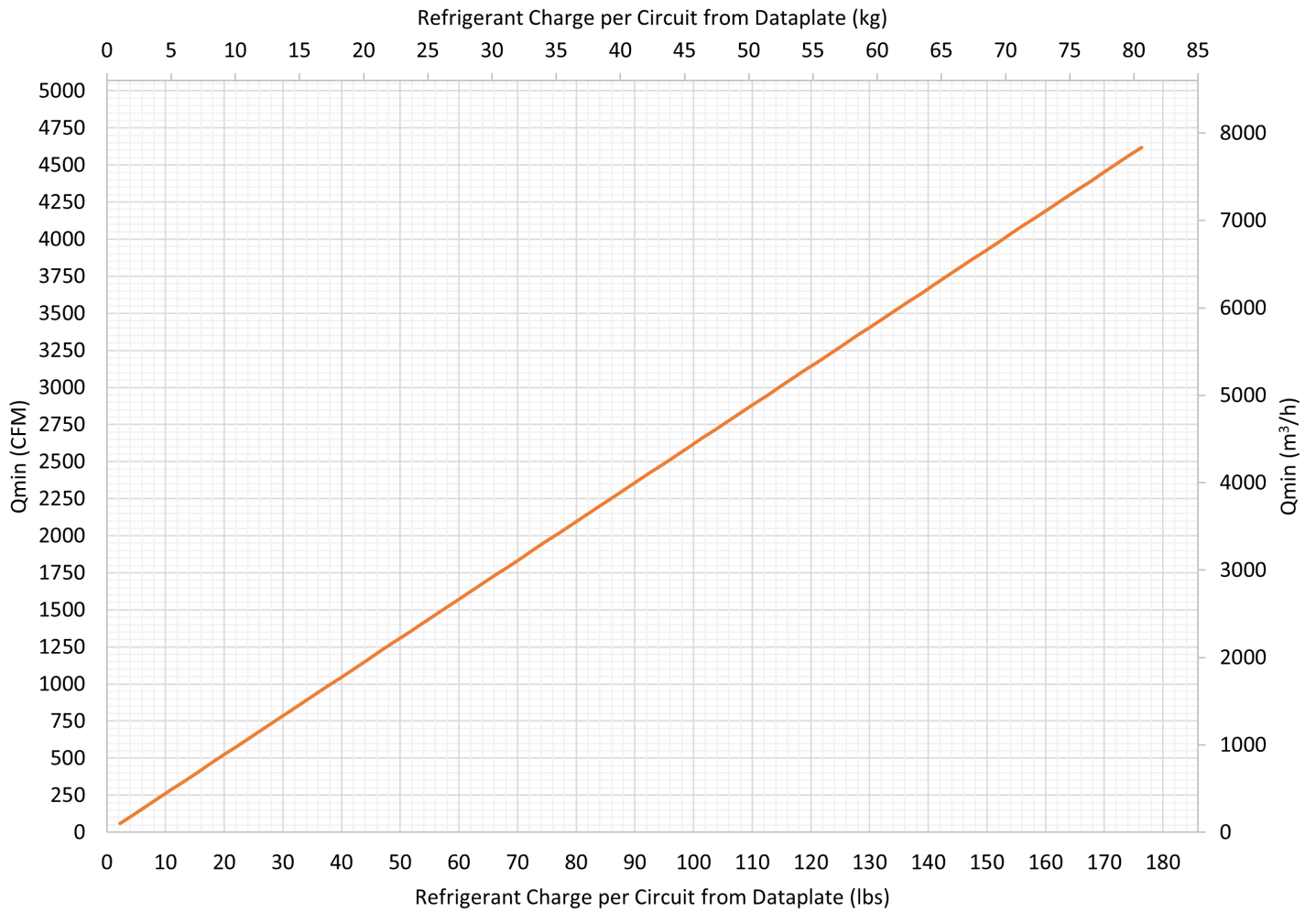

Figure 20: R-454B Refrigerant - Minimum Circulation of Airflow (Qmin)

Qmin (R454B)

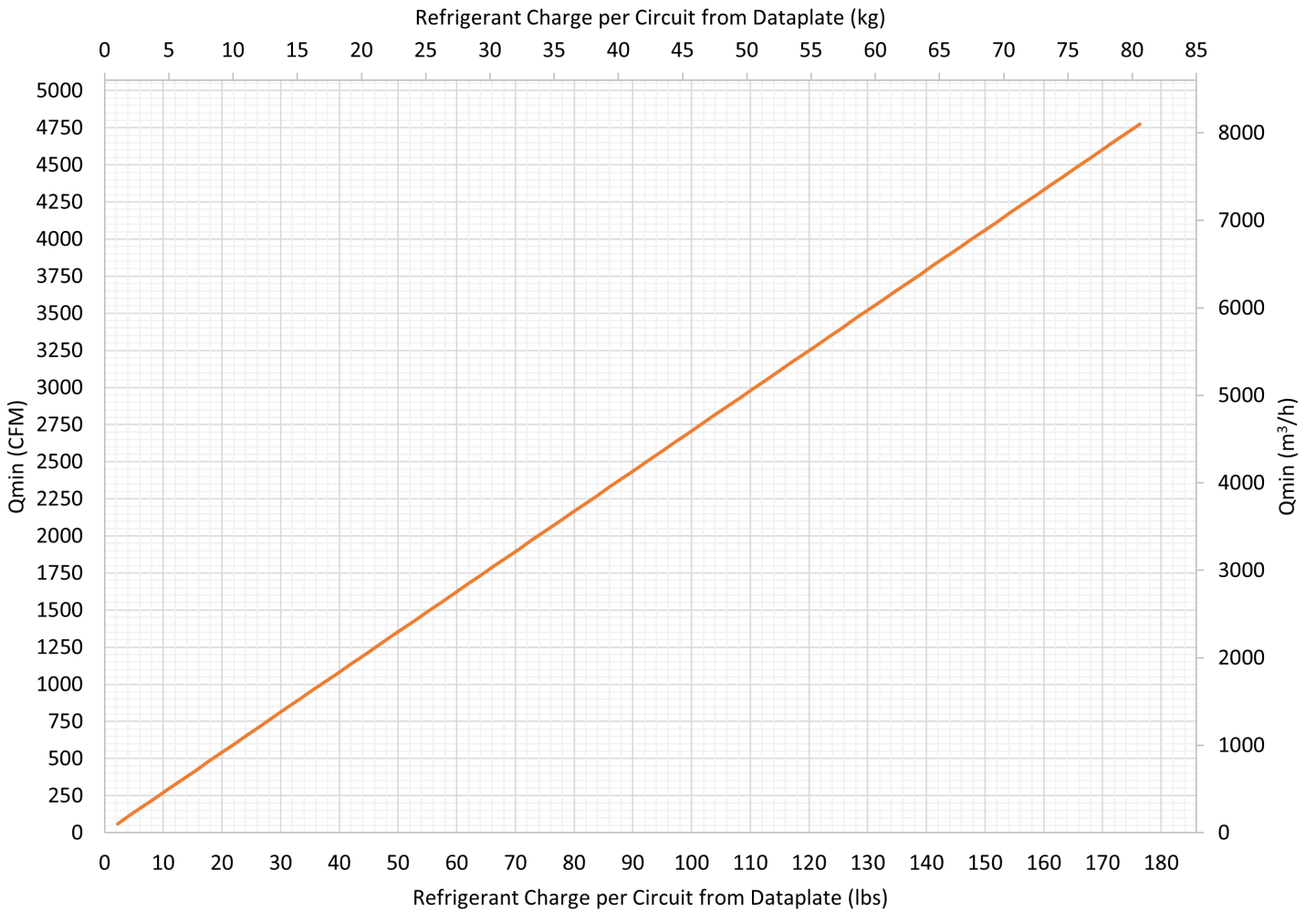

Figure 21: R-32 Refrigerant - Required Minimum Room Area Chart

Figure 22: R-454B Refrigerant - Required Minimum Room Area Chart

Performance Data

Coil Performance Data

Table 3: Horizontal Primary Coil Performance Data

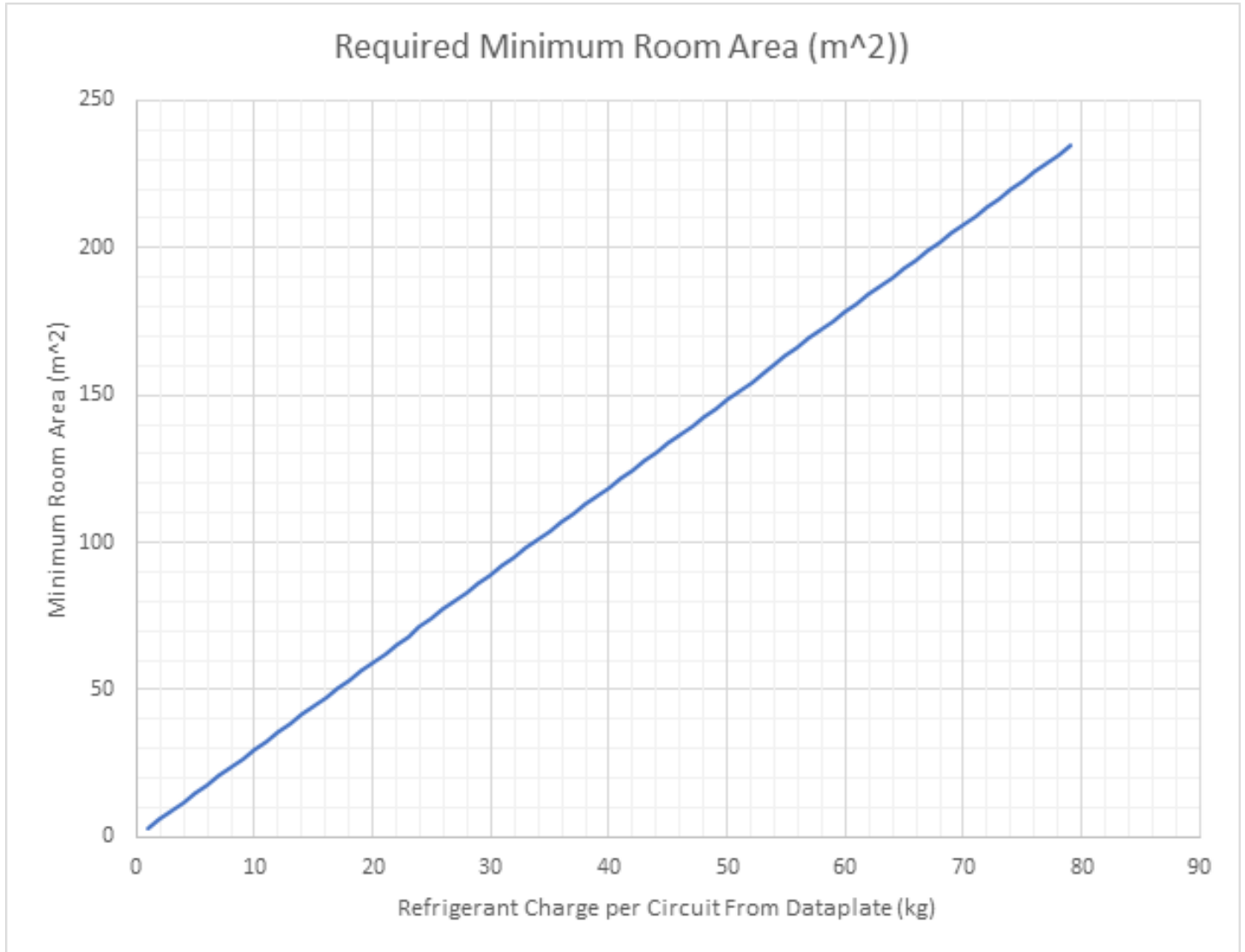
Unit Size	Nominal Air Flow SCFM	Number of Rows	Fins per Inch	Cooling Performance				Heating Performance		
				Total Btu/h	Sensible Btu/h	GPM	Pressure Drop (ft H ₂ O)	Total Btu/h	GPM	Pressure Drop (ft H ₂ O)
006	600	2	12	8285	8262	1.6	1.2	38546	3.9	4.2
	600	4	12	19780	14993	3.8	9.1	58375	6.0	15.6
	600	6	12	26520	18016	5.1	23.3	66142	6.8	28.7
	600	6	16	29069	19152	5.6	27.5	69062	7.1	31.0
008	800	2	12	13411	12686	2.5	2.9	52336	5.3	8.0
	800	4	12	28563	20882	5.5	19.5	78334	8.0	28.9
	800	6	12	32768	22938	6.3	6.1	87502	9.0	8.0
	800	6	16	36106	24405	6.9	7.1	91537	9.4	8.7
010	1000	2	12	22596	19085	4.1	8.4	71854	7.1	16.1
	1000	4	12	36476	26570	7.0	6.0	101574	10.0	8.0
	1000	6	12	47218	31347	9.1	14.1	112881	11.2	14.3
	1000	6	16	51232	33140	9.8	16.1	116798	11.5	14.9
012	1200	2	12	24882	21488	4.5	9.9	80775	8.2	20.9
	1200	4	12	41192	30655	7.9	7.5	117189	11.9	10.9
	1200	6	12	54109	36483	10.3	17.6	132547	13.5	19.9
	1200	6	16	59299	38805	11.4	21.1	138342	14.1	21.5
016	1600	2	12	28010	26033	5.1	3.1	105752	10.8	8.0
	1600	4	12	58780	42443	11.3	16.4	157291	16.1	21.6
	1600	6	12	67038	46500	13.6	4.7	175003	18.0	5.0
	1600	6	16	73468	49340	14.7	5.4	183116	18.9	5.5
018	1800	2	12	38310	33023	7.0	6.1	115294	7.8	4.8
	1800	4	12	65041	47467	12.5	8.5	172429	11.7	4.8
	1800	6	12	80327	54413	15.4	6.8	195031	13.2	3.4
	1800	6	16	87830	57733	16.8	7.9	204398	13.8	3.7
020	2000	2	12	40566	35381	7.4	6.7	134189	13.7	13.7
	2000	4	12	69725	51524	13.4	9.6	195600	20.0	12.5
	2000	6	12	87523	59682	17.0	8.1	220097	22.6	8.7
	2000	6	16	95586	63274	18.3	9.2	229920	23.6	9.4
030	3000	2	12	59500	52417	10.9	3.5	199425	19.7	10.1
	3000	4	12	103472	76822	19.9	7.0	291924	28.8	12.4
	3000	6	12	135652	91362	25.9	16.7	330663	32.7	21.3
	3000	6	16	148418	97087	28.5	19.7	345344	34.1	23.0
	3000	8	12	150537	97997	29.4	11.8	340113	23.1	5.4
	3000	8	16	160769	102575	31.4	13.2	350496	23.8	5.7
040	4000	2	12	83419	71800	15.2	5.1	267202	26.3	14.8
	4000	4	12	142700	104367	27.4	10.2	390733	38.6	18.1
	4000	6	12	176943	120156	34.1	9.1	439636	43.5	9.7
	4000	6	16	193604	127593	37.1	10.6	459471	45.4	10.5
	4000	8	12	203791	132010	39.8	16.2	454552	30.9	7.2
	4000	8	16	217118	138007	42.4	18.1	468126	31.8	7.6

Unit Size	Nominal Air Flow SCFM	Number of Rows	Fins per Inch	Cooling Performance				Heating Performance		
				Total Btu/h	Sensible Btu/h	GPM	Pressure Drop (ft H ₂ O)	Total Btu/h	GPM	Pressure Drop (ft H ₂ O)
050	5000	2	12	109441	92070	19.9	8.1	337534	34.3	23.6
	5000	4	12	172338	127969	33.1	5.5	487418	49.5	7.7
	5000	6	12	226130	152283	43.2	13.5	551645	56.1	14.8
	5000	6	16	247378	161816	47.5	15.9	576028	58.6	16.0
	5000	8	12	258465	166654	50.4	23.9	569502	38.7	10.5
	5000	8	16	275388	174312	53.7	26.7	586203	39.9	11.0
060	6000	2	12	119001	104835	21.8	3.5	398849	19.7	20.2
	6000	4	12	206944	153644	39.8	7.0	583847	28.8	24.8
	6000	6	12	271304	182724	51.8	16.7	661326	32.7	42.6
	6000	6	16	296835	194173	57.0	19.7	690689	34.1	46.0
	6000	8	12	301074	195994	58.8	26.3	680226	23.1	10.7
	6000	8	16	321538	205151	62.8	29.5	700991	23.8	11.3
080	8000	2	12	166839	143600	30.4	5.1	534403	26.3	29.5
	8000	4	12	285400	208734	54.8	10.2	781467	38.6	36.2
	8000	6	12	353885	240313	68.2	9.1	879272	43.5	19.5
	8000	6	16	387208	255186	74.2	10.6	918941	45.4	21.0
	8000	8	12	407581	264019	79.6	16.2	909105	30.9	14.5
	8000	8	16	434237	276014	84.8	18.1	936252	31.8	15.2
100	10000	2	12	218881	184140	39.8	8.1	675068	34.3	47.2
	10000	4	12	344676	255939	66.2	5.5	974836	49.5	15.5
	10000	6	12	452261	304566	86.4	13.5	1103289	56.1	29.7
	10000	6	16	494756	323633	95.0	15.9	1152055	58.6	32.0
	10000	8	12	516931	333308	100.8	23.9	1139003	38.7	20.9
	10000	8	16	550777	348624	107.4	26.7	1172406	39.9	22.1

NOTE 1: Cooling Conditions: EAT = 80/67, EWT = 45, LWT = 55

NOTE 2: Heating Conditions: EAT = 70, EWT = 180, LWT = 160

Table 4: Horizontal Secondary Coil Performance Data

Unit Size	Nominal Air Flow SCFM	Number of Rows	Fins per Inch	Heating Performance		
				Total Btu/h	GPM	Pressure Drop (ft H ₂ O)
006	600	1	12	22847	1.6	11.1
	600	1	16	27674	1.9	15.0
	600	2	12	34341	2.3	1.6
	600	2	16	39822	2.7	2.2
008	800	1	12	30681	2.1	20.1
	800	1	16	37213	2.5	27.2
	800	2	12	47375	3.2	3.3
	800	2	16	54704	3.7	4.3
010	1000	1	12	39210	2.7	2.2
	1000	1	16	47120	3.2	3.0
	1000	2	12	66353	4.5	7.2
	1000	2	16	76002	5.2	9.3

Unit Size	Nominal Air Flow SCFM	Number of Rows	Fins per Inch	Heating Performance		
				Total Btu/h	GPM	Pressure Drop (ft H ₂ O)
012	1200	1	12	42106	2.9	2.5
	1200	1	16	51100	3.5	3.5
	1200	2	12	74395	5.1	9.0
	1200	2	16	85512	5.8	11.3
016	1600	1	12	57591	3.9	4.8
	1600	1	16	70294	4.8	7.0
	1600	2	12	96106	6.5	3.2
	1600	2	16	110893	7.5	4.1
018	1800	1	12	71362	4.9	7.9
	1800	1	16	86405	5.9	11.2
	1800	2	12	115608	7.9	5.0
	1800	2	16	132455	9.0	6.4
020	2000	1	12	74335	5.1	8.5
	2000	1	16	90144	6.1	11.9
	2000	2	12	123139	8.4	5.6
	2000	2	16	141713	9.6	7.2
030	3000	1	12	111161	7.6	6.2
	3000	1	16	135183	9.2	8.7
	3000	2	12	183660	12.5	4.4
	3000	2	16	211760	14.4	5.7
040	4000	1	12	149701	10.2	9.0
	4000	1	16	181940	12.3	12.8
	4000	2	12	246953	16.8	6.5
	4000	2	16	284843	19.4	8.5
050	5000	1	12	190133	13.0	13.8
	5000	1	16	231263	15.7	19.6
	5000	2	12	311141	21.1	9.7
	5000	2	16	358946	24.4	12.7
060	6000	1	12	222322	15.2	6.2
	6000	1	16	270365	18.4	8.7
	6000	2	12	367321	25.0	4.4
	6000	2	16	423521	28.8	5.7
080	8000	1	12	299402	20.4	9.0
	8000	1	16	363881	24.6	12.8
	8000	2	12	493905	33.6	6.5
	8000	2	16	569686	38.8	8.5
100	10000	1	12	380266	26.0	13.8
	10000	1	16	462525	31.4	19.6
	10000	2	12	622283	42.2	9.7
	10000	2	16	717893	48.8	12.7

NOTE 1: Heating Conditions: EAT = 70, EWT = 180, LWT = 150

Table 5: Vertical Primary Coil Performance Data - Unit Sizes 006-050

Unit Size	Nominal Air Flow SCFM	Number of Rows	Fins per Inch	Cooling Performance				Heating Performance		
				Total Btu/h	Sensible Btu/h	GPM	Pressure Drop (ft H ₂ O)	Total Btu/h	GPM	Pressure Drop (ft H ₂ O)
006	600	2	12	10384	9751	2.4	2.5	38546	3.9	4.2
	600	4	12	20354	15231	4.1	10.4	58375	6	15.6
	600	6	12	22634	16412	4.5	3.0	65245	6.8	4.4
	600	6	16	25421	17613	5.1	3.8	68317	7.1	4.7
008	800	2	12	16072	14127	3.6	5.0	52427	5.3	6.7
	800	4	12	21502	17968	4.3	1.5	76399	8	3.5
	800	6	12	32078	22656	6.4	4.4	87261	9	6.1
	800	6	16	35542	24168	7.1	5.3	91329	9.4	6.6
012	1200	2	12	25258	21627	5.7	6.8	81294	10.8	14.6
	1200	4	12	36969	28873	7.4	3.6	117392	16.1	11.0
	1200	6	12	51162	35229	10.2	9.1	132683	18	18.4
	1200	6	16	56333	37525	11.3	10.9	138468	18.9	20.1
016	1600	2	12	29250	26882	7	1.7	108048	13.7	4.5
	1600	4	12	55369	41072	11.1	6.8	158908	20	14.7
	1600	6	12	65316	45795	12.9	4.5	177265	22.6	9.8
	1600	6	16	72818	49067	14.6	5.6	184737	23.6	10.6
020	2000	2	12	40853	35652	9.5	3.2	140601	23.1	12.6
	2000	4	12	63352	48917	12.7	3.4	197631	26.3	10.4
	2000	6	12	87141	59521	17.4	8.3	224423	38.6	28.4
	2000	6	16	95856	63390	19.2	9.9	233321	43.5	35.2
030	3000	2	12	65773	55660	14.7	4.1	219457	45.4	36.9
	3000	4	12	102379	76467	20.5	5.2	294492	30.9	10.8
	3000	6	12	135945	91512	27.2	12.7	332094	34.3	17.3
	3000	6	16	148481	97120	29.7	14.9	348412	49.5	10.2
	3000	8	16	159545	102028	31.9	9.3	357445	56.1	38.7
040	4000	2	12	86452	73332	18.1	5.9	289056	58.6	39.6
	4000	4	12	140068	103293	28	8.1	388985	38.7	11.3
	4000	6	12	173928	118890	34.8	6.7	438217	43.5	6.8
	4000	6	16	191140	126533	38.2	7.9	458315	45.4	7.4
	4000	8	16	214869	136996	43	16.1	466495	30.9	5.1
050	5000	2	12	111359	93297	24.2	6.8	335266	34.3	10.2
	5000	4	12	176302	129673	35.3	8.8	488710	49.5	13.0
	5000	6	12	218061	148903	43.6	9.8	549724	56.1	7.1
	5000	6	16	239613	158466	47.9	11.7	574328	58.6	7.6
	5000	8	16	269144	171496	53.9	17.4	583644	38.7	5.0

NOTE 1: Cooling Conditions: EAT = 80/67, EWT = 45, LWT = 55

NOTE 2: Heating Conditions: EAT = 70, EWT = 180, LWT = 160

Table 6: Vertical Primary Coil Performance Data - Unit Sizes 060-100

Unit Size	Nominal Air Flow SCFM	Number of Rows	Fins per Inch	Cooling Performance			
				Total Btu/h	Sensible Btu/h	GPM	Pressure Drop (ft H ₂ O)
060	6000	2	12	147344	120002	29.5	3.9
	6000	4	12	228955	162865	45.8	16.8
	6000	6	12	272400	183239	54.8	12.6
	6000	8	12	298665	194955	59.8	8.1
060	6000	2	16	180326	140549	36.1	5.7
	6000	4	16	259528	177578	51.9	21.1
	6000	6	16	297195	194340	59.5	14.6
	6000	8	16	319416	204203	63.9	9.1
080	8000	2	12	191010	155671	38.2	6.2
	8000	4	12	280147	206591	56	7.9
	8000	6	12	347621	237682	69.5	6.5
	8000	8	12	402541	261808	80.6	14
080	8000	2	16	232217	181760	46.5	9
	8000	4	16	321428	226438	64.3	10.2
	8000	6	16	380691	252384	75.3	7.5
	8000	8	16	430076	274143	86	15.8
100	10000	2	12	242347	197303	45.5	6.5
	10000	4	12	385854	273022	77.2	26.3
	10000	6	12	435975	297745	87.2	9.6
	10000	8	12	504446	327825	100.9	15.1
100	10000	2	16	294603	230265	59	9.4
	10000	4	16	437495	297963	87.5	33.1
	10000	6	16	477031	315989	94.3	11.1
	10000	8	16	538631	343145	107.7	17

NOTE: Cooling Conditions: EAT = 80/67, EWT = 45, LWT = 55

Table 7: Vertical Turbo Spiral (Primary Coil) Performance Data - Unit Sizes 060-100

Unit Size	Nominal Air Flow SCFM	Number of Rows	Fins per Inch	Cooling Performance			
				Total Btu/h	Sensible Btu/h	GPM	Pressure Drop (ft H ₂ O)
060	6000	2	12	106594	92903	24.2	9.3
	6000	4	12	183735	142829	41.9	8.9
	6000	6	12	233048	164559	53.1	6.4
080	8000	2	12	142856	124337	32.4	13.6
	8000	4	12	244962	190385	55.8	12.8
	8000	6	12	306317	219086	69.8	8.8
100	10000	2	12	177950	155524	40.4	13.9
	10000	4	12	316911	242224	72.2	12.1
	10000	6	12	391676	278616	89.2	9

NOTE: Cooling Conditions: EAT = 80/67, EWT = 45, LWT = 55

Table 8: Vertical Secondary Coil Performance Data - Unit Sizes 006-050

Unit Size	Nominal Air Flow SCFM	Number of Rows	Fins per Inch	Heating Performance		
				Total Btu/h	GPM	Pressure Drop (ft H ₂ O)
006	600	1	12	20855	1.4	1.2
	600	2	12	34726	2.4	1.8
	600	2	16	39822	2.7	2.2
008	800	1	12	29043	2	2.9
	800	2	12	47804	3.3	2.9
	800	2	16	55135	3.8	3.7
012	1200	1	12	38550	2.6	0.7
	1200	2	12	71299	4.9	3.7
	1200	2	16	82196	5.6	4.7
016	1600	1	12	56894	3.9	1.6
	1600	2	12	93484	6.4	1.1
	1600	2	16	107930	7.4	1.5
020	2000	1	12	72252	4.9	2.7
	2000	2	12	119338	8.2	1.9
	2000	2	16	137497	9.4	2.5
030	3000	1	12	101901	6.9	0.6
	3000	2	12	184159	12.6	3.4
	3000	2	16	212101	14.5	4.5
040	4000	1	12	135748	9.2	0.9
	4000	2	12	244336	16.7	4.0
	4000	2	16	281953	19.3	5.2
050	5000	1	12	171113	11.6	0.9
	5000	2	12	307110	21	4.2
	5000	2	16	354011	24.2	5.4

NOTE: Heating Conditions: EAT = 70, EWT = 180, LWT = 150

Table 9: Vertical Secondary Coil Performance Data - Unit Sizes 060-100

Unit Size	Nominal Air Flow SCFM	Number of Rows	Fins per Inch	Heating Performance		
				Total Btu/h	GPM	Pressure Drop (ft H ₂ O)
060	6000	1	12	233318	24	1.7
	6000	2	12	380833	38.8	0.57
060	6000	1	16	283090	28.8	2.47
	6000	2	16	439107	44.8	0.74
080	8000	1	12	308314	31.7	2.42
	8000	2	12	506542	51.7	0.8
080	8000	1	16	375394	38.5	3.5
	8000	2	16	584716	59.7	1.03
100	10000	1	12	388568	39.9	2.61
	10000	2	12	636618	65	0.79
100	10000	1	16	472882	48.6	3.79
	10000	2	16	734461	75	1.02

NOTE: Heating Conditions: EAT = 70, EWT = 180, LWT = 160

Table 10: Horizontal DX Coil Performance Data - R-32

Unit Size	Circuits		Fin Height	Fin Length	CFM	FPI	Cooling					Heating			
							Total	Sensible	LAT		APD	Total	Sensible	LAT	APD
	DB	WB							DB						
006	1	Normal	14	12.5	600	12	20076	14646	57.68	56.37	0.379	20735	10369	101.6	0.317
						16	22600	16066	55.51	54.87	0.518	22995	11499	105.05	0.4326
008	1	Normal	14	16.5	800	12	25958	19195	58.06	56.73	0.385	27259	9089	101.16	0.322
						16	29483	21150	55.82	55.16	0.525	30243	10083	104.57	0.4392
010	1	Normal	14	25	1000	12	36382	25830	56.38	55.33	0.29	36878	9221	103.72	0.2381
						16	40807	28196	54.21	53.72	0.4	40472	10119	107.01	0.3284
012	1	Normal	14	25	1200	12	40479	29423	57.58	56.27	0.379	41783	10447	101.84	0.317
						16	45671	32324	55.37	54.73	0.518	46304	11577	105.29	0.4326
016	1	Normal	14	33	1600	12	54392	39373	57.5	56.18	0.385	55837	11169	101.91	0.322
						16	61235	43224	55.29	54.65	0.525	61899	12381	105.38	0.4392
018	1	Normal	14	41.5	1800	12	62781	45216	57.03	55.87	0.327	64730	9249	102.89	0.2703
						16	70863	49588	54.81	54.25	0.449	71347	10193	106.25	0.3711
020	1	Normal	22	41.5	2000	12	66756	48745	57.71	56.4	0.382	69513	9932	101.78	0.319
						16	75614	53660	55.46	54.82	0.521	77042	11007	105.23	0.4352
030	1	Normal	22	39.5	3000	12	98689	72530	57.89	56.57	0.383	103955	9452	101.69	0.3204
						16	112086	79940	55.63	54.98	0.523	115222	10476	105.12	0.4371
	2	Interlaced	22	39.5	3000	12	98689	72530	57.89	56.57	0.383	103955	9452	101.69	0.3204
						16	112086	79940	55.63	54.98	0.523	115222	10476	105.12	0.4371
040	1	Normal	26	44.5	4000	12	135397	98212	57.55	56.23	0.384	139860	10760	101.98	0.3211
						16	152820	107956	55.32	54.67	0.524	154967	11921	105.43	0.4381
	2	Interlaced	26	44.5	4000	12	135397	98212	57.55	56.23	0.384	139860	10760	101.98	0.3211
						16	152820	107956	55.32	54.67	0.524	154967	11921	105.43	0.4381
050	1	Normal	28	51.5	5000	12	175738	126452	56.87	55.77	0.386	176375	12599	102.26	0.3226
						16	197618	138787	54.62	54.19	0.526	195429	13960	105.74	0.44
	2	Interlaced	28	51.5	5000	12	175738	126452	56.87	55.77	0.386	176375	12599	102.26	0.3226
						16	197618	138787	54.62	54.19	0.526	195429	13960	105.74	0.44
060	2	Normal	44	39.5	6000	12	201407	148020	57.44	56.33	0.383	208269	9468	101.74	0.3204
						16	228747	163142	55.13	54.7	0.523	230804	10492	105.18	0.4371
	4	Interlaced	44	39.5	6000	12	201407	148020	57.44	56.33	0.383	208269	9468	101.74	0.3204
						16	228747	163142	55.13	54.7	0.523	230804	10492	105.18	0.4371
080	2	Normal	52	44.5	8000	12	276321	200432	57.09	55.99	0.384	323582	12447	99.59	0.4566
						16	311877	220317	54.82	54.39	0.524	362585	13946	103.16	0.615
	4	Interlaced	52	44.5	8000	12	276321	200432	57.09	55.99	0.384	323582	12447	99.59	0.4566
						16	311877	220317	54.82	54.39	0.524	362585	13946	103.16	0.615
100	2	Normal	56	51.5	10000	12	351475	252904	56.87	55.77	0.386	353140	12613	102.29	0.3226
						16	395236	277573	54.62	54.19	0.526	391238	13973	105.78	0.44
	4	Interlaced	56	51.5	10000	12	351475	252904	56.87	55.77	0.386	353140	12613	102.29	0.3226
						16	395236	277573	54.62	54.19	0.526	391238	13973	105.78	0.44

NOTE 1: Capacity is based on 80/67°F DB/WB entering air and 45°F entering suction temperatures. Total and sensible capacities are Btu/h.

NOTE 2: Capacity is based on 70°F entering air and 110°F entering saturated liquid temperatures. Total and sensible capacities are Btu/h.

Table 11: Horizontal DX Coil Performance Data - R-454B

Unit Size	Circuits		Fin Height	Fin Length	CFM	FPI	Cooling					Heating			
							Total	Sensible	LAT		APD	Total	Sensible	LAT	APD
	DB	WB							DB						
006	1	Normal	14	12.5	600	12	21248	15114	56.96	55.68	0.379	20694	10349	101.54	0.317
						16	23698	16514	54.83	54.2	0.518	22936	11468	104.96	0.4326
008	1	Normal	14	16.5	800	12	27978	20000	57.14	55.84	0.385	27207	9072	101.1	0.322
						16	31503	21973	54.88	54.24	0.525	30186	10064	104.51	0.4392
010	1	Normal	14	25	1000	12	38797	26814	55.48	54.46	0.29	36879	9221	103.73	0.2381
						16	43344	29253	53.25	52.76	0.4	40493	10124	107.03	0.3284
012	1	Normal	14	25	1200	12	42946	30410	56.83	55.54	0.379	41822	10457	101.87	0.317
						16	48149	33337	54.59	53.97	0.518	46351	11588	105.32	0.4326
016	1	Normal	14	33	1600	12	57283	40532	56.83	55.54	0.385	55917	11185	101.96	0.322
						16	64179	44429	54.61	53.97	0.525	61989	12398	105.43	0.4392
018	1	Normal	14	41.5	1800	12	67496	47119	56.06	54.93	0.327	64849	9266	102.95	0.2703
						16	75639	51562	53.8	53.26	0.449	71514	10218	106.33	0.3711
020	1	Normal	22	41.5	2000	12	71532	50656	56.84	55.55	0.382	69657	9952	101.85	0.319
						16	80389	55613	54.57	53.94	0.521	77250	11037	105.32	0.4352
030	1	Normal	22	39.5	3000	12	106357	75593	56.96	55.66	0.383	104271	9481	101.78	0.3204
						16	119847	83108	54.67	54.03	0.523	115652	10515	105.25	0.4371
	2	Interlaced	22	39.5	3000	12	106357	75593	56.96	55.66	0.383	104271	9481	101.78	0.3204
						16	119847	83108	54.67	54.03	0.523	115652	10515	105.25	0.4371
040	1	Normal	26	44.5	4000	12	143388	101413	56.81	55.52	0.384	140224	10787	102.06	0.3211
						16	161127	111357	54.54	53.91	0.524	155475	11960	105.55	0.4381
	2	Interlaced	26	44.5	4000	12	143388	101413	56.81	55.52	0.384	140224	10787	102.06	0.3211
						16	161127	111357	54.54	53.91	0.524	155475	11960	105.55	0.4381
050	1	Normal	28	51.5	5000	12	180011	127059	56.76	55.47	0.386	176751	12625	102.33	0.3226
						16	200643	138869	54.6	53.97	0.526	195904	13994	105.83	0.44
	2	Interlaced	28	51.5	5000	12	180011	127059	56.76	55.47	0.386	176751	12625	102.33	0.3226
						16	200643	138869	54.6	53.97	0.526	195904	13994	105.83	0.44
060	2	Normal	44	39.5	6000	12	212715	151187	56.96	55.66	0.383	209060	9504	101.86	0.3204
						16	239694	166216	54.67	54.03	0.523	231819	10538	105.33	0.4371
	4	Interlaced	44	39.5	6000	12	212715	151187	56.96	55.66	0.383	209060	9504	101.86	0.3204
						16	239694	166216	54.67	54.03	0.523	231819	10538	105.33	0.4371
080	2	Normal	52	44.5	8000	12	286776	202827	56.81	55.52	0.384	325089	12504	99.73	0.4566
						16	322253	222713	54.54	53.91	0.524	364331	14012	103.32	0.615
	4	Interlaced	52	44.5	8000	12	286776	202827	56.81	55.52	0.384	325089	12504	99.73	0.4566
						16	322253	222713	54.54	53.91	0.524	364331	14012	103.32	0.615
100	2	Normal	56	51.5	10000	12	360022	254119	56.76	55.47	0.386	354067	12645	102.38	0.3226
						16	401286	277737	54.6	53.97	0.526	392356	14013	105.88	0.44
	4	Interlaced	56	51.5	10000	12	360022	254119	56.76	55.47	0.386	354067	12645	102.38	0.3226
						16	401286	277737	54.6	53.97	0.526	392356	14013	105.88	0.44

NOTE 1: Capacity is based on 80/67°F DB/WB entering air and 45°F entering suction temperatures. Total and sensible capacities are Btu/h.

NOTE 2: Capacity is based on 70°F entering air and 115°F entering saturated liquid temperatures. Total and sensible capacities are Btu/h.

Table 12: Vertical DX Coil Performance Data - R-32

Unit Size	Rows	Circuits		Fin Height	Fin Length	CFM	FPI	Cooling					Heating			
		Number	Type					Total	Sensible	LAT		APD	Total	Sensible	LAT	
										DB	WB				DB	APD
006	3	1	Normal	14	12.5	600	12	20076	14646	57.68	56.37	0.379	20735	10369	101.6	0.317
							14	21450	15444	56.46	55.56	0.443	21992	10998	103.52	0.3703
							16	22600	16066	55.51	54.87	0.518	22995	11499	105.05	0.4326
	6	1	Normal	14	12.5	600	12	28439	18629	51.61	51.21	0.759	26633	8877	110.59	0.6339
							14	29433	19059	50.95	50.56	0.886	27286	9095	111.59	0.7406
							16	30191	19391	50.45	50.05	1.036	27743	9247	112.28	0.8652
008	3	1	Normal	16	14.5	800	12	26008	19220	58.03	56.7	0.383	27306	9105	101.21	0.3198
							14	27956	20327	56.76	55.85	0.447	28960	9656	103.11	0.3736
							16	29518	21168	55.8	55.15	0.522	30306	10104	104.64	0.4364
	6	1	Normal	16	14.5	800	12	37950	24852	51.59	51.19	0.765	35479	8870	110.56	0.6397
							14	39295	25434	50.93	50.53	0.894	36356	9089	111.56	0.7472
							16	40321	25884	50.41	50.02	1.044	36970	9242	112.26	0.8727
012	3	1	Normal	18	18.5	1200	12	40219	29227	57.73	56.35	0.408	41671	13891	101.76	0.3428
							14	42869	30805	56.52	55.57	0.476	44239	14747	103.71	0.3999
							16	44914	31967	55.64	54.95	0.556	46290	15430	105.28	0.4665
	6	1	Normal	18	18.5	1200	12	56287	37004	51.8	51.4	0.816	52919	8820	110.33	0.6856
							14	58405	37918	51.1	50.71	0.952	54293	9049	111.38	0.7998
							16	60034	38629	50.56	50.17	1.111	55263	9210	112.11	0.933
016	3	1	Normal	20	23.5	1600	12	54790	39571	57.38	56.09	0.375	56199	11241	102.12	0.3134
							14	58468	41706	56.16	55.27	0.439	59559	11913	104.04	0.3662
							16	61541	43372	55.21	54.58	0.513	62243	12449	105.58	0.428
	6	1	Normal	20	23.5	1600	12	75999	49747	51.57	51.17	0.751	72022	12003	111.16	0.6269
							14	78346	50762	50.99	50.59	0.877	73663	12277	112.1	0.7325
							16	79976	51475	50.58	50.19	1.025	74781	12463	112.74	0.8559
020	3	1	Normal	20	29	2000	12	69906	50443	56.94	55.84	0.383	70166	11695	102.08	0.3198
							14	68756	48304	55.46	54.68	0.384	69025	11505	105.07	0.3175
							16	78473	55290	54.72	54.3	0.522	77754	12959	105.55	0.4364
	6	1	Normal	20	29	2000	12	95671	62473	51.43	51.04	0.765	89299	8930	110.83	0.6397
							14	99133	63977	50.75	50.35	0.894	83314	8331	112.33	0.6351
							16	101778	65141	50.21	49.83	1.044	92972	9297	112.51	0.8727
030	3	1	Normal	26	34.5	3000	12	100836	73523	57.59	56.32	0.366	105301	9574	102.1	0.3048
							14	108086	77635	56.33	55.46	0.428	111532	10141	104	0.3564
							16	114191	80874	55.35	54.72	0.5	116518	10594	105.52	0.4166
	6	2	Interlaced	26	34.5	3000	12	100836	73523	57.59	56.32	0.366	105301	9574	102.1	0.3048
							14	108086	77635	56.33	55.46	0.428	111532	10141	104	0.3564
							16	114191	80874	55.35	54.72	0.5	116518	10594	105.52	0.4166
040	3	1	Normal	30	38.5	4000	12	145610	94620	51.16	50.76	0.731	135231	10402	111.22	0.6096
							14	150276	96657	50.54	50.14	0.855	138303	10638	112.16	0.7127
							16	153772	98200	50.07	49.68	1	140399	10800	112.8	0.8333
	6	2	Interlaced	30	38.5	4000	12	130413	96222	58	56.67	0.385	138307	9222	101.62	0.322
							14	140118	101748	56.74	55.82	0.45	146625	9776	103.52	0.3761
							16	148335	106123	55.74	55.08	0.525	153314	10222	105.05	0.4392
6	2	Interlaced	30	38.5	4000	12	130413	96222	58	56.67	0.385	138307	9222	101.62	0.322	
						14	140118	101748	56.74	55.82	0.45	146625	9776	103.52	0.3761	
						16	148335	106123	55.74	55.08	0.525	153314	10222	105.05	0.4392	
6	2	Interlaced	30	38.5	4000	12	191463	124998	51.42	51.02	0.77	178604	8930	110.83	0.644	
						14	198463	128041	50.73	50.33	0.899	182952	9148	111.83	0.7522	
						16	203810	130393	50.19	49.8	1.05	185969	9298	112.52	0.8785	

Unit Size	Rows	Circuits		Fin Height	Fin Length	CFM	FPI	Cooling					Heating										
		Number	Type					Total	Sensible	LAT		APD	Total	Sensible	LAT								
										DB	WB				DB	WB							
050	3	1	Normal	38	38.5	5000	12	163933	120739	57.92	56.61	0.378	173750	9146	101.78	0.3154							
							14	176096	127641	56.65	55.75	0.441	184130	9692	103.68	0.3685							
							16	186382	133100	55.66	55.01	0.515	192461	10131	105.2	0.4305							
		2	Interlaced	38	38.5	5000	12	163933	120739	57.92	56.61	0.378	173750	9146	101.78	0.3154							
							14	176096	127641	56.65	55.75	0.441	184130	9692	103.68	0.3685							
							16	186382	133100	55.66	55.01	0.515	192461	10131	105.2	0.4305							
	6	2	Interlaced	38	38.5	5000	12	239744	156427	51.39	50.99	0.755	225299	11858	111.21	0.6308							
							14	247436	159770	50.78	50.38	0.882	230434	12128	112.15	0.7369							
							16	252811	162130	50.35	49.96	1.031	233927	12312	112.78	0.861							
							060	3	2	Normal	40	43.5	6000	12	202350	147045	57.59	56.28	0.383	209819	10492	101.98	0.3198
														14	216628	155251	56.34	55.43	0.447	222398	11121	103.9	0.3736
														16	228644	161707	55.35	54.71	0.522	232460	11624	105.43	0.4364
4	Interlaced	40	43.5	6000	12	202350			147045	57.59	56.28	0.383	209819	10492	101.98	0.3198							
					14	216628			155251	56.34	55.43	0.447	222398	11121	103.9	0.3736							
					16	228644			161707	55.35	54.71	0.522	232460	11624	105.43	0.4364							
6	2	Interlaced	40	43.5	6000	12		283151	185756	51.69	51.29	0.765	270575	13528	111.24	0.6397							
						14		291481	189353	51.14	50.74	0.894	276667	13833	112.17	0.7472							
						16		297202	191846	50.76	50.37	1.044	280787	14039	112.8	0.8727							
						080		3	2	Normal	54	43.5	8000	12	273341	197614	57.41	56.12	0.376	281777	10839	102.21	0.3136
														14	292247	208489	56.17	55.28	0.439	298516	11482	104.12	0.3665
														16	308112	217020	55.19	54.56	0.513	311898	11997	105.65	0.4282
4	Interlaced	54	43.5	8000	12		273341		197614	57.41	56.12	0.376	281777	10839	102.21	0.3136							
					14		292247		208489	56.17	55.28	0.439	298516	11482	104.12	0.3665							
					16		308112		217020	55.19	54.56	0.513	311898	11997	105.65	0.4282							
6	2	Interlaced	54	43.5	8000		12	376618	247282	51.73	51.33	0.751	361585	13907	111.33	0.6273							
							14	387259	251871	51.21	50.81	0.878	369539	14213	112.24	0.733							
							16	394503	255022	50.85	50.45	1.026	374887	14418	112.85	0.8565							
							100	3	2	Normal	68	43.5	10000	12	340150	246522	57.46	56.17	0.372	352255	10362	102.21	0.31
														14	364043	260183	56.21	55.32	0.434	373161	10976	104.13	0.3623
														16	384114	270914	55.23	54.6	0.508	389839	11467	105.65	0.4235
4	Interlaced	68	43.5	10000	12	340150			246522	57.46	56.17	0.372	352255	10362	102.21	0.31							
					14	364043			260183	56.21	55.32	0.434	373161	10976	104.13	0.3623							
					16	384114			270914	55.23	54.6	0.508	389839	11467	105.65	0.4235							
6	2	Interlaced	68	43.5	10000	12		475033	310933	51.57	51.17	0.743	452294	13303	111.36	0.6201							
						14		488838	316908	51.02	50.62	0.868	462220	13594	112.27	0.7247							
						16		498315	321047	50.64	50.25	1.015	468897	13791	112.88	0.8469							

NOTE 1: Capacity is based on 80/67°F DB/WB entering air and 45°F entering suction temperatures. Total and sensible capacities are Btu/h.

NOTE 2: Capacity is based on 70°F entering air and 110°F entering saturated liquid temperatures. Total and sensible capacities are Btu/h.

Table 13: Vertical DX Coil Performance Data - R-454B

Unit Size	Rows	Circuits		Fin Height	Fin Length	CFM	FPI	Cooling					Heating			
		Number	Type					Total	Sensible	LAT		APD	Total	Sensible	LAT	
										DB	WB				DB	APD
006	3	1	Normal	14	12.5	600	12	21248	15114	56.96	55.68	0.379	20694	10349	101.54	0.317
							14	22588	15903	55.76	54.88	0.443	21938	10970	103.44	0.3703
							16	23698	16514	54.83	54.2	0.518	22936	11468	104.96	0.4326
	6	1	Normal	14	12.5	600	12	29805	19222	50.7	50.31	0.759	26531	8844	110.44	0.6339
							14	30774	19649	50.05	49.66	0.886	27178	9059	111.42	0.7406
							16	31506	19975	49.56	49.17	1.036	27629	9210	112.11	0.8652
008	3	1	Normal	16	14.5	800	12	28000	20014	57.12	55.83	0.383	27255	9088	101.16	0.3198
							14	29906	21113	55.87	54.97	0.447	28903	9637	103.04	0.3736
							16	31502	21975	54.88	54.24	0.522	30231	10078	104.56	0.4364
	6	1	Normal	16	14.5	800	12	39845	25675	50.65	50.26	0.765	35346	8836	110.4	0.6397
							14	41163	26256	49.99	49.6	0.894	36215	9054	111.4	0.7472
							16	42160	26701	49.48	49.09	1.044	36821	9205	112.09	0.8727
012	3	1	Normal	18	18.5	1200	12	41311	29663	57.39	56.03	0.408	41651	13884	101.74	0.3428
							14	43764	31164	56.25	55.3	0.476	44191	14730	103.68	0.3999
							16	45622	32253	55.42	54.74	0.556	46230	15409	105.23	0.4665
	6	1	Normal	18	18.5	1200	12	59365	38336	50.78	50.39	0.816	52791	8799	110.23	0.6856
							14	61462	39260	50.08	49.69	0.952	54152	9025	111.27	0.7998
							16	63057	39970	49.54	49.16	1.111	55110	9185	112	0.933
016	3	1	Normal	20	23.5	1600	12	57528	40671	56.75	55.49	0.375	56282	11258	102.17	0.3134
							14	61327	42866	55.5	54.63	0.439	59641	11929	104.09	0.3662
							16	64295	44499	54.57	53.95	0.513	62327	12466	105.62	0.428
	6	1	Normal	20	23.5	1600	12	77617	50446	51.17	50.77	0.751	71822	11970	111.05	0.6269
							14	79792	51394	50.63	50.23	0.877	73434	12238	111.97	0.7325
							16	81286	52052	50.25	49.86	1.025	74526	12420	112.6	0.8559
020	3	1	Normal	20	29	2000	12	71723	50726	56.81	55.52	0.383	70291	11716	102.14	0.3198
							14	76440	53464	55.55	54.67	0.447	69128	11522	105.12	0.3175
							16	80111	55497	54.62	53.99	0.522	77883	12981	105.61	0.4364
	6	1	Normal	20	29	2000	12	100873	64741	50.4	50.01	0.765	89196	8919	110.78	0.6397
							14	104365	66290	49.69	49.3	0.894	83189	8319	112.26	0.6351
							16	106983	67466	49.15	48.77	1.044	92806	9280	112.44	0.8727
030	3	1	Normal	26	34.5	3000	12	108323	76524	56.67	55.43	0.366	105600	9601	102.19	0.3048
							14	115621	80692	55.4	54.55	0.428	111909	10175	104.11	0.3564
							16	121722	83960	54.41	53.8	0.5	116916	10630	105.64	0.4166
	6	2	Interlaced	26	34.5	3000	12	108323	76524	56.67	55.43	0.366	105600	9601	102.19	0.3048
							14	115621	80692	55.4	54.55	0.428	111909	10175	104.11	0.3564
							16	121722	83960	54.41	53.8	0.5	116916	10630	105.64	0.4166
040	3	1	Normal	30	38.5	4000	12	151152	97042	50.42	50.03	0.731	135009	10385	111.15	0.6096
							14	155949	99168	49.77	49.38	0.855	138024	10617	112.07	0.7127
							16	159317	100678	49.31	48.93	1	140070	10774	112.7	0.8333
	6	2	Interlaced	30	38.5	4000	12	140968	100435	57.04	55.74	0.385	138788	9254	101.73	0.322
							14	150802	106062	55.75	54.86	0.45	147236	9817	103.66	0.3761
							16	159074	110502	54.74	54.1	0.525	153965	10265	105.2	0.4392
050	3	1	Normal	38	38.5	5000	12	202251	129705	50.35	49.96	0.77	178493	8924	110.81	0.644
							14	209250	132813	49.64	49.25	0.899	182756	9138	111.78	0.7522
							16	214575	135208	49.09	48.71	1.05	185700	9285	112.46	0.8785
	6	2	Interlaced	38	38.5	5000	12	177272	126068	56.94	55.66	0.378	174389	9180	101.9	0.3154
							14	189605	133102	55.66	54.78	0.441	184928	9734	103.82	0.3685
							16	199970	138647	54.64	54.02	0.515	193310	10175	105.36	0.4305
6	2	Interlaced	38	38.5	5000	12	177272	126068	56.94	55.66	0.378	174389	9180	101.9	0.3154	
						14	189605	133102	55.66	54.78	0.441	184928	9734	103.82	0.3685	
						16	199970	138647	54.64	54.02	0.515	193310	10175	105.36	0.4305	
6	2	Interlaced	38	38.5	5000	12	246332	159288	50.87	50.47	0.755	224861	11834	111.13	0.6308	
						14	253594	162476	50.28	49.89	0.882	229890	12099	112.05	0.7369	
						16	258634	164710	49.87	49.49	1.031	233291	12278	112.67	0.861	

Unit Size	Rows	Circuits		Fin Height	Fin Length	CFM	FPI	Cooling					Heating			
		Number	Type					Total	Sensible	LAT		APD	Total	Sensible	LAT	
										DB	WB				DB	APD
060	3	2	Normal	40	43.5	6000	12	215652	152374	56.78	55.49	0.383	210483	10525	102.08	0.3198
							14	229867	160617	55.52	54.63	0.447	223209	11161	104.02	0.3736
							16	241737	167067	54.54	53.91	0.522	233323	11667	105.56	0.4364
		4	Interlaced	40	43.5	6000	12	215652	152374	56.78	55.49	0.383	210483	10525	102.08	0.3198
							14	229867	160617	55.52	54.63	0.447	223209	11161	104.02	0.3736
							16	241737	167067	54.54	53.91	0.522	233323	11667	105.56	0.4364
	6	2	Interlaced	40	43.5	6000	12	286771	187314	51.45	51.05	0.765	269881	13493	111.13	0.6397
							14	294349	190600	50.95	50.55	0.894	275835	13791	112.04	0.7472
							16	299503	192854	50.61	50.21	1.044	279836	13991	112.65	0.8727
							12	289097	203941	56.69	55.42	0.376	282636	10871	102.31	0.3136
							14	308881	215244	55.4	54.52	0.439	299600	11524	104.25	0.3665
							16	324461	223725	54.43	53.81	0.513	313041	12041	105.78	0.4282
080	3	2	Normal	54	43.5	8000	12	289097	203941	56.69	55.42	0.376	282636	10871	102.31	0.3136
							14	308881	215244	55.4	54.52	0.439	299600	11524	104.25	0.3665
							16	324461	223725	54.43	53.81	0.513	313041	12041	105.78	0.4282
		4	Interlaced	54	43.5	8000	12	289097	203941	56.69	55.42	0.376	282636	10871	102.31	0.3136
							14	308881	215244	55.4	54.52	0.439	299600	11524	104.25	0.3665
							16	324461	223725	54.43	53.81	0.513	313041	12041	105.78	0.4282
	6	2	Interlaced	54	43.5	8000	12	379889	248687	51.57	51.17	0.751	360583	13868	111.22	0.6273
							14	389450	252821	51.1	50.7	0.878	368346	14167	112.11	0.733
							16	395910	255637	50.78	50.38	1.026	373530	14366	112.7	0.8565
							12	361468	255072	56.67	55.42	0.372	353477	10397	102.33	0.31
							14	386572	269332	55.37	54.51	0.434	374610	11019	104.26	0.3623
							16	406441	280073	54.39	53.78	0.508	391358	11511	105.79	0.4235
100	3	2	Normal	68	43.5	10000	12	361468	255072	56.67	55.42	0.372	353477	10397	102.33	0.31
							14	386572	269332	55.37	54.51	0.434	374610	11019	104.26	0.3623
							16	406441	280073	54.39	53.78	0.508	391358	11511	105.79	0.4235
		4	Interlaced	68	43.5	10000	12	361468	255072	56.67	55.42	0.372	353477	10397	102.33	0.31
							14	386572	269332	55.37	54.51	0.434	374610	11019	104.26	0.3623
							16	406441	280073	54.39	53.78	0.508	391358	11511	105.79	0.4235
	6	2	Interlaced	68	43.5	10000	12	481738	313827	51.3	50.9	0.743	451169	13269	111.26	0.6201
							14	494346	319310	50.8	50.41	0.868	460860	13554	112.15	0.7247
							16	502909	323065	50.46	50.06	1.015	467333	13745	112.74	0.8469

NOTE 1: Capacity is based on 80/67°F DB/WB entering air and 45°F entering suction temperatures. Total and sensible capacities are Btu/h.

NOTE 2: Capacity is based on 70°F entering air and 115°F entering saturated liquid temperatures. Total and sensible capacities are Btu/h.

Table 14: Vertical Steam Coil Performance Data

Unit Size	Nominal Air Flow SCFM	Number of Rows	Fins per Inch	EAT	PSI	Heating Performance	
				DB		Total Btu/h	Pressure Drop (PSI)
006	600	1	10	55	5	30049.0	0.18
008	800	1	10	55	5	41468.0	0.16
012	1200	1	10	55	5	61975.0	0.16
016	1600	1	10	55	5	87533.0	0.14
020	2000	1	10	55	5	106985.0	0.15
030	3000	1	10	55	5	151774.0	0.15
040	4000	1	10	55	5	202671.0	0.15
050	5000	1	10	55	5	258119.0	0.15

Table 15: Horizontal Steam Coil Performance Data

Unit Size	Nominal Air Flow SCFM	Number of Rows	Fins per Inch	EAT	PSI	Heating Performance	
				DB		Total Btu/h	Pressure Drop (PSI)
006	600	1	10	55	5	22229.0	0.36
008	800	1	10	55	5	33948.0	0.26
010	1000	1	10	55	5	54590.0	0.14
012	1200	1	10	55	5	57961.0	0.19
016	1600	1	10	55	5	80691.0	0.17
018	1800	1	10	55	5	97625.0	0.14
020	2000	1	10	55	5	101153.0	0.16
030	3000	1	10	55	5	153469.0	0.16
040	4000	1	10	55	5	207617.0	0.15
050	5000	1	10	55	5	264380.0	0.14
060	6000	1	10	55	5	306938	0.16
080	8000	1	10	55	5	415234	0.15
100	10000	1	10	55	5	528760	0.14

Heating Data

Table 16: Horizontal Minimum Allowable Air Volume with Electric Heat (Unit Sizes 006-020)

Unit Size	006	008	010	012	016	018	020
kW	Air Volume - CFM						
0.41	300	400	600	600	800	1000	1000
0.5	300	400	600	600	800	1000	1000
0.82	300	400	600	600	800	1000	1000
1	300	400	600	600	800	1000	1000
1.64	300	400	600	600	800	1000	1000
2	300	400	600	600	800	1000	1000
2.45	300	400	600	600	800	1000	1000
3	300	400	600	600	800	1000	1000
3.27	300	400	600	600	800	1000	1000
4	300	400	600	600	800	1000	1000
4.09	300	400	600	600	800	1000	1000
4.91	300	400	600	600	800	1000	1000
5	300	400	600	600	800	1000	1000
6	-	400	600	600	800	1000	1000
6.54	-	400	600	600	800	1000	1000
7.36	-	425	600	600	800	1000	1000
8	-	460	600	600	800	1000	1000
8.18	-	470	600	600	800	1000	1000
9	-	515	600	600	800	1000	1000
9.81	-	570	600	600	800	1000	1000
10	-	575	600	600	800	1000	1000
10.6	-	-	-	-	800	1000	1000
11	-	-	-	-	800	1000	1000
11.3	-	-	-	-	800	1000	1000
12	-	-	-	-	800	1000	1000
13	-	-	-	-	800	1000	1000

Table 17: Horizontal Minimum Allowable Air Volume With Electric Heat (Unit Sizes 030-100)

Unit Size	Forward-Curved Fan Units			Plenum Fan Units					
	030	040	050	030	040	050	060	080	100
kW	Air Volume - CFM			Air Volume - CFM					
7.36	1500	2000	2500	1800	2400	3000	-	-	-
9	1500	2000	2500	1800	2400	3000	-	-	-
15	1500	2000	2500	1800	2400	3000	-	-	-
17	-	-	-	-	-	-	3600	-	-
18	1500	2000	2500	1800	2400	3000	-	-	-
19	-	-	-	-	-	-	3600	-	-
20	-	-	-	-	-	-	3600	-	-
21	1500	2000	2500	1800	2400	3000	-	-	-
24	1500	2000	2500	1800	2400	3000	-	-	-
25	-	-	-	-	-	-	-	4800	-
28.9	-	-	-	-	-	-	-	4800	6000
30	-	2000	2500	-	2400	3000	-	-	-
32	-	-	-	-	-	-	-	4800	6000
34.4	-	-	-	-	-	-	3600	-	-
36	-	2060	2500	-	2400	3000	-	-	-
38	-	-	-	-	-	-	3600	-	-
39	-	2250	2500	-	2400	3000	-	-	-
40	-	-	-	-	-	-	3600	-	-
43.4	-	-	-	-	-	-	-	4800	6000
48	-	-	-	-	-	-	-	4800	6000
50	-	-	-	-	-	-	-	4800	-
57	-	-	-	-	-	-	3600	4800	6000
60	-	-	-	-	-	-	3600	-	-
63	-	-	-	-	-	-	3603	4800	6000
65	-	-	-	-	-	-	-	4800	6000
75	-	-	-	-	-	-	4290	4800	-
95	-	-	-	-	-	-	5433	6000	6000
105	-	-	-	-	-	-	-	6005	-
133	-	-	-	-	-	-	-	-	7607

NOTE: Limits are based on greater value of either:
 1. 250 FPM face velocity across the electric heating coil or
 2. Entering Air of 70°F and a maximum of 125°F LAT

Table 18: Vertical Minimum Allowable Air Volume With Electric Heat

Unit Size	006	008	012	016	020
kW	Air Volume - CFM				
0.82	300	-	-	-	-
1	300	400	-	-	-
1.64	-	400	600	-	-
2	300	400	600	800	1000
2.45	300	-	-	-	-
3	300	-	-	-	-
3.27	-	400	600	800	1000
4	300	400	600	800	1000
4.8	-	400	600	-	-
4.91	300	-	-	-	-
6	345	-	-	-	-
6.54	-	400	600	800	1000
8	-	460	600	800	1000
8.18	-	470	600	800	1000
9.6	-	550	600	800	1000
10	-	575	600	800	1000
12	-	-	-	800	1000
19.2	-	-	-	-	1100

Unit Size	Forward-Curved Fan Units			Plenum Fan Units		
	030	040	050	030	040	050
kW	Air Volume - CFM			Air Volume - CFM		
6.8	1500	2000	2500	1800	2400	3000
9	1500	2000	2500	1800	2400	3000
11.3	1500	2000	2500	1800	2400	3000
13.5	1500	2000	2500	1800	2400	3000
15	1500	2000	2500	1800	2400	3000
18	1500	2000	2500	1800	2400	3000
21	1500	2000	2500	1800	2400	3000
24	1500	2000	2500	1800	2400	3000
39	2235	2235	2500	1800	2400	3000

NOTE: Limits are based on greater value of either:
 1. 250 FPM face velocity across the electric heating coil or
 2. Entering Air of 70°F and a maximum of 125°F LAT

Table 19: Horizontal Electric Heat kW Options by Unit Size

Unit Size	Voltage	Horizontal kW												
006	120/60/1	0.5	1.0	2.0	3.0	4.0	-	-	-	-	-	-	-	-
	208/60/1	0.4	0.8	1.6	2.5	3.3	4.1	4.9	-	-	-	-	-	-
	230/60/1	0.5	1.0	2.0	3.0	4.0	5.0	6.0	-	-	-	-	-	-
	277/60/1	-	1.0	2.0	3.0	4.0	5.0	6.0	-	-	-	-	-	-
	460/60/1	-	1.0	-	3.0	-	-	6.0	-	-	-	-	-	-
008	120/60/1	0.5	1.0	2.0	3.0	4.0	5.0	-	-	-	-	-	-	-
	208/60/1	0.4	0.8	1.6	2.5	3.3	4.1	4.9	6.5	8.2	-	-	-	-
	230/60/1	0.5	1.0	2.0	3.0	4.0	5.0	6.0	8.0	-	10.0	-	-	-
	277/60/1	0.5	1.0	2.0	3.0	4.0	5.0	6.0	8.0	-	10.0	-	-	-
	460/60/1	-	-	2.0	-	4.0	5.0	-	8.0	-	10.0	-	-	-
010	120/60/1	0.5	1.0	2.0	3.0	4.0	5.0	-	-	-	-	-	-	-
	208/60/1	0.4	0.8	1.6	2.5	3.3	4.1	4.9	6.5	8.2	-	-	-	-
	230/60/1	0.5	1.0	2.0	3.0	4.0	5.0	6.0	8.0	-	10.0	-	-	-
	277/60/1	0.5	1.0	2.0	3.0	4.0	5.0	6.0	8.0	-	10.0	-	-	-
	460/60/1	-	-	2.0	-	4.0	5.0	-	8.0	-	10.0	-	-	-
012	120/60/1	0.5	1.0	2.0	3.0	4.0	5.0	-	-	-	-	-	-	-
	208/60/1	0.4	0.8	1.6	2.5	3.3	4.1	4.9	6.5	8.2	-	-	-	-
	230/60/1	0.5	1.0	2.0	3.0	4.0	5.0	6.0	8.0	-	10.0	-	-	-
	277/60/1	0.5	1.0	2.0	3.0	4.0	5.0	6.0	8.0	-	10.0	-	-	-
	460/60/1	-	-	2.0	-	4.0	5.0	-	8.0	-	10.0	-	-	-
016	120/60/1	-	1.0	2.0	-	4.0	5.0	-	-	-	-	-	-	-
	208/60/1	-	0.8	1.6	-	3.3	-	4.9	6.5	8.2	-	-	-	-
	230/60/1	-	1.0	2.0	-	4.0	-	6.0	8.0	-	10.0	-	-	-
	277/60/1	-	1.0	2.0	-	4.0	-	6.0	8.0	-	10.0	-	12.0	13.0
	460/60/1	-	-	-	-	4.0	-	-	8.0	-	10.0	12.0	16.0	20.0
018	120/60/1	-	1.0	2.0	-	4.0	5.0	-	-	-	-	-	-	-
	208/60/1	-	0.8	1.6	-	3.3	-	4.9	6.5	8.2	9.0	-	-	-
	230/60/1	-	1.0	2.0	-	4.0	-	6.0	8.0	-	10.0	11.0	-	-
	277/60/1	-	1.0	2.0	-	4.0	-	6.0	8.0	-	10.0	-	12.0	13.0
	460/60/1	-	-	-	-	4.0	-	-	8.0	-	10.0	12.0	17.0	20.0
020	120/60/1	-	1.0	2.0	-	4.0	5.0	-	-	-	-	-	-	-
	208/60/1	-	0.8	1.6	-	3.3	-	4.9	6.5	8.2	9.0	-	-	-
	230/60/1	-	1.0	2.0	-	4.0	-	6.0	8.0	-	10.0	11.0	-	-
	277/60/1	-	1.0	2.0	-	4.0	-	6.0	8.0	-	10.0	-	12.0	13.0
	460/60/1	-	-	-	-	4.0	-	-	8.0	-	10.0	12.0	17.0	20.0
030	208/60/3	6.8	11.3	13.5	-	-	-	-	-	-	-	-	-	-
	240/60/3	9.0	15.0	18.0	-	-	-	-	-	-	-	-	-	-
	460/60/3	9.0	15.0	18.0	21.0	24.0	-	-	-	-	-	-	-	-
	575/60/3	9.0	15.0	18.0	21.0	24.0	-	-	-	-	-	-	-	-
040	208/60/3	6.8	11.3	13.5	-	-	-	-	-	-	-	-	-	-
	240/60/3	9.0	15.0	18.0	-	-	-	-	-	-	-	-	-	-
	460/60/3	9.0	15.0	18.0	21.0	24.0	30.0	36.0	39.0	-	-	-	-	-
	575/60/3	9.0	15.0	18.0	21.0	24.0	30.0	36.0	39.0	-	-	-	-	-
050	208/60/3	6.8	11.3	13.5	-	-	-	-	-	-	-	-	-	-
	240/60/3	9.0	15.0	18.0	-	-	-	-	-	-	-	-	-	-
	460/60/3	9.0	15.0	18.0	21.0	24.0	30.0	36.0	39.0	-	-	-	-	-
	575/60/3	9.0	15.0	18.0	21.0	24.0	30.0	36.0	39.0	-	-	-	-	-
060	208/60/3	17.2	-	-	-	34.4	-	-	57	-	-	-	-	-
	240/60/3	19	-	-	-	38	-	-	63	-	-	-	-	-
	460/60/3	-	20	-	-	-	40	-	63	-	75	-	-	-
	575/60/3	-	20	-	-	-	40	-	63	-	75	-	-	-
080	208/60/3	-	-	-	28.9	-	-	43.4	57	-	-	-	-	-
	240/60/3	-	-	-	32	-	-	48	63	-	-	-	-	-
	460/60/3	-	-	25	-	-	-	50	-	-	75	-	105	-
	575/60/3	-	-	25	-	-	-	50	-	-	-	95	105	-
100	208/60/3	-	-	-	28.9	-	-	43.4	57	-	-	-	-	-
	240/60/3	-	-	-	32	-	-	48	63	-	-	-	-	-
	460/60/3	-	-	-	32	-	-	-	-	65	-	95	-	133
	575/60/3	-	-	-	32	-	-	-	-	65	-	95	-	133

Vertical Electric Heat kW Options - Unit Sizes 006-050

Unit Size	Voltage	Vertical kW												
006	120/60/1	-	1	2	-	4	-	-	-	-	-	-	-	-
	208/60/1	-	0.8	-	2.5	3.3	-	4.9	-	-	-	-	-	-
	230/60/1	-	1.0	-	3.0	4.0	-	6.0	-	-	-	-	-	-
	277/60/1	-	1.0	-	3.0	4.0	-	6.0	-	-	-	-	-	-
	460/60/1	-	1.0	-	3.0	-	6.0	-	-	-	-	-	-	-
008	120/60/1	-	1.0	2.0	-	4.0	-	-	-	-	-	-	-	-
	208/60/1	-	-	1.6	-	3.3	-	-	6.5	8.2	-	-	-	-
	230/60/1	-	-	2.0	-	4.0	-	-	8.0	-	10.0	-	-	-
	277/60/1	-	-	2.0	-	4.0	-	-	8.0	-	10.0	-	-	-
	460/60/1	-	-	2.0	-	4.0	5.0	-	8.0	-	10.0	-	-	-
012	120/60/1	-	-	2.0	-	4.0	-	-	-	-	-	-	-	-
	208/60/1	-	-	1.6	-	3.3	-	-	6.5	8.2	-	-	-	-
	230/60/1	-	-	2.0	-	4.0	-	-	8.0	-	10.0	-	-	-
	277/60/1	-	-	2.0	-	4.0	-	-	8.0	-	10.0	-	-	-
	460/60/1	-	-	2.0	-	4.0	5.0	-	8.0	-	10.0	-	-	-
016	120/60/1	-	-	2.0	-	4.0	-	-	-	-	-	-	-	-
	208/60/1	-	-	-	-	3.3	-	-	6.5	8.2	-	-	-	-
	230/60/1	-	-	-	-	4.0	-	-	8.0	-	10.0	-	-	-
	277/60/1	-	-	-	-	4.0	-	-	8.0	-	10.0	12.0	-	-
	460/60/1	-	-	-	-	4.0	-	-	8.0	-	10.0	12.0	-	-
020	120/60/1	-	-	2.0	-	4.0	-	-	-	-	-	-	-	-
	208/60/1	-	-	-	-	3.3	-	-	6.5	8.2	-	-	-	-
	230/60/1	-	-	-	-	4.0	-	-	8.0	-	10.0	-	-	-
	277/60/1	-	-	-	-	4.0	-	-	8.0	-	10.0	12.0	-	-
	460/60/1	-	-	-	-	4.0	-	-	8.0	-	10.0	12.0	-	20.0
030	208/60/3	6.8	11.3	13.5	-	-	-	-	-	-	-	-	-	-
	240/60/3	9.0	15.0	18.0	-	-	-	-	-	-	-	-	-	-
	460/60/3	9.0	15.0	-	21.0	24.0	-	-	-	-	-	-	-	-
	575/60/3	9.0	15.0	-	21.0	24.0	-	-	-	-	-	-	-	-
040	208/60/3	6.8	11.3	13.5	-	-	-	-	-	-	-	-	-	-
	240/60/3	9.0	15.0	18.0	-	-	-	-	-	-	-	-	-	-
	460/60/3	9.0	15.0	-	21.0	24.0	-	-	39.0	-	-	-	-	-
	575/60/3	9.0	15.0	-	21.0	24.0	-	-	39.0	-	-	-	-	-
050	208/60/3	6.8	11.3	13.5	-	-	-	-	-	-	-	-	-	-
	240/60/3	9.0	15.0	18.0	-	-	-	-	-	-	-	-	-	-
	460/60/3	9.0	15.0	-	21.0	24.0	-	-	39.0	-	-	-	-	-
	575/60/3	9.0	15.0	18.0	21.0	24.0	-	-	39.0	-	-	-	-	-

Table 20: Vertical Defrost Electric Heat kW Options - Unit Sizes 060-100

Unit Size	Voltage	Vertical kW												
060	208/60/3	11.27	22.53	37.56	-	-	-	-	-	-	-	-	-	-
	240/60/3	15	30	50	-	-	-	-	-	-	-	-	-	-
	460/60/3	15	30	50	59	70	-	-	-	-	-	-	-	-
	575/60/3	15	30	50	59	70	-	-	-	-	-	-	-	-
080	208/60/3	11.27	22.53	37.56	44.32	-	-	-	-	-	-	-	-	-
	240/60/3	15	30	50	59	-	-	-	-	-	-	-	-	-
	460/60/3	15	30	50	59	70	90	-	-	-	-	-	-	-
	575/60/3	15	30	50	59	70	90	-	-	-	-	-	-	-
100	208/60/3	11.27	22.53	37.56	44.32	-	-	-	-	-	-	-	-	-
	240/60/3	15	30	50	59	-	-	-	-	-	-	-	-	-
	460/60/3	15	30	50	59	70	90	110	-	-	-	-	-	-
	575/60/3	15	30	50	59	70	90	110	-	-	-	-	-	-

Table 21: Vertical Defrost Post Electric Heat kW Options - Unit Sizes 060-100

Unit Size	Voltage	Vertical kW																
		208/60/3	240/60/3	460/60/3	575/60/3	11.27	22.53	37.56	45.07	52.58	67.6	82.62	93.89	-	-	-	-	-
060	208/60/3	11.27	22.53	37.56	45.07	52.58	67.6	82.62	93.89	-	-	-	-	-	-	-	-	-
	240/60/3	15	30	50	60	70	90	110	125	-	-	-	-	-	-	-	-	-
	460/60/3	15	30	50	60	70	90	110	125	150	-	-	-	-	-	-	-	-
	575/60/3	15	30	50	60	70	90	110	125	150	-	-	-	-	-	-	-	-
080	208/60/3	11.27	22.53	37.56	45.07	52.58	67.6	82.62	93.89	-	-	-	-	-	-	-	-	-
	240/60/3	15	30	50	60	70	90	110	125	-	-	-	-	-	-	-	-	-
	460/60/3	15	30	50	60	70	90	110	125	150	175	200	-	-	-	-	-	-
	575/60/3	15	30	50	60	70	90	110	125	150	175	200	-	-	-	-	-	-
100	208/60/3	11.27	22.53	37.56	45.07	52.58	67.6	82.62	93.89	-	-	-	-	-	-	-	-	-
	240/60/3	15	30	50	60	70	90	110	125	-	-	-	-	-	-	-	-	-
	460/60/3	15	30	50	60	70	90	110	125	150	175	200	250	-	-	-	-	-
	575/60/3	15	30	50	60	70	90	110	125	150	175	200	250	-	-	-	-	-

Table 22: Horizontal Unit - Heater Amps

Horizontal Heater Amps												
kW	120V/1Ø	230V/1Ø	277V/1Ø	460V/1Ø	kW	240V/3Ø	460V/3Ø	575V/3Ø	kW	208V/1Ø†	208V/3Ø†	
0.5	4.17	2.17	1.81	-	0.5	1.20	0.63	0.50	0.41	1.97	-	
1	8.33	4.35	3.61	2.17	1	2.41	1.26	1.00	0.82	3.94	-	
2	16.67	8.70	7.22	4.35	2	4.81	2.51	2.01	1.64	7.88	-	
3	25.00	13.04	10.83	6.52	3	7.22	3.77	3.01	2.45	11.78	-	
4	33.33	17.39	14.44	8.70	4	9.62	5.02	4.02	3.27	15.72	-	
5	41.67	21.74	18.05	10.87	5	12.03	6.28	5.02	4.09	19.66	-	
6	-	26.09	21.66	13.04	6	14.43	7.53	6.02	4.91	23.61	-	
8	-	34.78	28.88	17.39	8	19.25	10.04	8.03	6.54	31.44	-	
10	-	43.48	-	21.74	9	21.65	11.30	9.04	6.80	-	35.38	
11	-	47.83	39.71	-	10	24.06	12.55	10.04	8.18	39.33	-	
12	-	-	43.32	26.09	11	26.46	13.81	11.04	9.00	43.27	-	
13	-	-	46.93	-	12	28.87	15.06	12.05	9.81	47.16	-	
18	-	-	-	39.13	13	31.27	16.32	13.05	10.63	51.11	-	
21	-	-	-	45.65	15	36.08	18.83	15.06	11.30	-	54.33	
					18	43.30	22.59	18.07	13.50	-	64.90	
					19	45.70	-	-	17.2	-	47.70	
					20	-	24.10	19.20	28.9	-	80.30	
					21	-	26.36	21.09	34.4	-	95.40	
					24	-	30.12	24.10	43.4	-	120.50	
					25	-	30.10	-	57	-	158.10	
					30	-	37.65	30.12				
					36	-	45.18	36.15				
					39	-	48.95	39.16				
					40	-	48.1	38.5				
					48	115.5	-	-				
					50	-	60.1	-				
					60	-	72.2	57.7				
					63	151.6	-	-				
					65	-	-	62.5				
					75	-	90.2	72.2				
					95	-	-	91.4				
					105	-	126.3	1.1				
					133	-	160	128				

NOTE: † Indicates that 208V single and three phase applications make use of a de-rated 230/240V heater.

Table 23: Vertical Unit - Heater Amps - Unit Sizes 006-050

Vertical Heater Amps (Unit Sizes 006-050)											
kW	115V/1Ø	230V/1Ø	277V/1Ø	480V/1Ø	kW	240V/3Ø	480V/3Ø	600V/3Ø	kW	208V/1Ø†	208V/3Ø†
1	8.7	4.3	3.6	2.1	9	21.7	10.8	8.7	0.82	3.9	-
2	17.4	8.7	7.2	4.2	15	36.1	18.0	14.4	1.64	7.9	-
3	-	13.0	10.8	6.3	18	43.3	-	-	2.45	11.8	-
4	34.8	17.4	14.4	8.3	21	-	25.3	20.2	3.27	15.7	-
5	-	-	-	10.87	24	-	28.9	23.1	4.09	19.7	-
6	-	26.1	21.7	12.5	39	-	46.9	37.5	4.91	23.6	-
8	-	34.8	28.9	16.7					6.54	31.5	-
10	-	43.5	36.1	20.83					6.80	-	18.8
12	-	-	43.3	25.0					8.18	39.3	-
19.2	-	-	-	40.0					11.3	-	31.3
									13.5	-	37.5

NOTE: † Indicates that 208V single and three phase applications make use of a de-rated 230/240V heater.

Table 24: Vertical Unit - Defrost Heater Amps - Unit Sizes 060-100

Vertical Heater Amps (Unit Sizes 060-100)				
kW	208V/3Ø	230V/3Ø	480V/3Ø	575V/3Ø
15	34.05	37.65	18.83	15.06
30	68.10	75.31	37.65	30.12
50	113.51	125.51	62.76	50.20
59	133.94	148.10	74.05	59.24
70	-	-	87.86	70.29
90	-	-	112.96	90.37
110	-	-	138.06	110.45

NOTE: † Indicates that 208V single and three phase applications make use of a de-rated 230/240V heater.

Table 25: Vertical Unit - Post Heater Amps - Unit Sizes 060-100

Vertical Heater Amps (Unit Sizes 060-100)				
kW	208V/3Ø	230V/3Ø	480V/3Ø	575V/3Ø
15	34.05	37.65	18.83	15.06
30	68.10	75.31	37.65	30.12
50	113.51	125.51	62.76	50.20
59	136.21	150.61	75.31	60.25
70	158.91	175.72	87.86	70.29
90	204.31	225.92	112.96	90.37
110	249.71	276.12	138.06	110.45
125	283.76	313.78	156.89	125.51
150	-	-	188.27	150.61
175	-	-	219.64	175.72
200	-	-	251.02	200.82
250	-	-	313.78	251.02

NOTE: † Indicates that 208V single and three phase applications make use of a de-rated 230/240V heater.

Energy Recovery Wheel Performance Data

Table 26: Pressure Drop Through Energy Recovery Wheel (in H₂O)

	Wheel Diameter (in)	46			52			58		
	Efficiency	Low	Medium	High	Low	Medium	High	Low	Medium	High
Airflow (CFM)	1000	-	-	0.32	-	-	-	-	-	-
	2000	0.36	0.43	0.61	0.26	0.31	0.44	0.22	0.27	0.38
	3000	0.53	0.64	0.91	0.38	0.46	0.65	0.32	0.39	0.55
	4000	0.71	0.85	1.21	0.50	0.61	0.86	0.42	0.51	0.72
	5000	0.88	1.06	-	0.62	0.75	1.07	0.52	0.63	0.90
	6000	1.04	-	-	0.74	0.90	-	0.62	0.76	1.07
	7000	-	-	-	0.87	1.05	-	0.72	0.88	1.25
	8000	-	-	-	0.99	1.20	-	0.82	1.00	-
	9000	-	-	-	1.11	-	-	0.92	1.12	-
	10000	-	-	-	-	-	-	1.02	1.25	-
11000	-	-	-	-	-	-	1.12	-	-	

Table 27: Energy Recovery Wheel Sizes and Airflows

Wheel Diameter (in)	Wheel Efficiency	Min Airflow (CFM)	Max Airflow (CFM)	Material	Option of Bypass Damper	Bypass Damper Airflow (CFM)
46	High	866	4410	Polymer	Yes	5205
	Medium	1076	5960	Polymer	Yes	5205
	Low	1050	6800	Polymer	Yes	5205
52	High	1233	5950	Polymer	No	N/A
	Medium	1522	8475	Polymer	No	N/A
	Low	1500	9800	Polymer	No	N/A
58	High	1470	7100	Polymer	No	N/A
	Medium	1811	10200	Polymer	No	N/A
	Low	1800	11000	Polymer	No	N/A

Table 28: Energy Recovery Wheel Performance

Wheel Diameter (in)	Efficiency	Outside and Exhaust Airflow (CFM)	Summer Conditions					Winter Conditions				
			Wheel LDB (F)	Wheel LWB (F)	Recovery Capacity (Btu/hr)	Sensible Efficiency	Total Efficiency	Wheel LDB (F)	Wheel LWB (F)	Recovery Capacity (Btu/hr)	Sensible Efficiency	Total Efficiency
46	Low	3000	81.2	68.5	114711	67.7	66.0	58.6	50.7	118044	68.5	67.3
	Medium	3000	80.4	68.0	120152	71.9	69.1	59.8	51.5	123623	72.0	70.5
	High	3000	79.7	67.4	126976	75.6	73.1	61.2	52.4	130682	76.0	74.6
52	Low	4000	81.0	68.3	155604	68.9	67.1	59.0	51.0	160075	69.6	68.5
	Medium	4000	80.2	67.8	162724	73.1	70.2	60.2	51.7	167432	73.2	71.6
	High	4000	81.0	68.3	171732	68.9	67.1	59.0	51.0	176673	69.6	68.5
58	Low	5000	81.1	68.3	192825	68.3	66.6	58.9	50.9	198395	69.0	67.9
	Medium	5000	80.3	67.9	201810	72.5	69.7	60.1	51.6	207641	72.6	71.1
	High	5000	79.6	67.3	213127	76.1	73.6	61.5	52.5	219301	76.5	75.0

NOTE 1: Summer conditions based on 95°F DB and 78°F WB outdoor air temperature and 75°F DB and 63°F WB return air temperature.

NOTE 2: Winter conditions based on 35°F DB and 33°F WB outdoor air temperature and 70°F DB and 58°F WB return air temperature.

Electrical Data

Field Power Wiring

DANGER

Improper ground may result in severe injury or death.

Check grounding nut tightness before connecting power to the external junction box.

DANGER

Hazardous voltage. Can cause severe injury or death.

Disconnect electric power before servicing equipment. More than one disconnect may be required to de-energize the unit.

Wiring must comply with all applicable codes and ordinances. The warranty is voided if wiring is not in accordance with these specifications. An open fuse or starter indicates a short, ground, or overload. Before replacing a fuse or resetting a starter, identify the trouble and correct.

According to the National Electric Code, a disconnecting means shall be located within sight of and readily accessible from the air conditioning equipment. Power leads must be over-current protected at the point of distribution. The maximum allowable overcurrent protection (MROPD) appears on the unit nameplate.

Supply Power Wiring

1. Allowable voltage tolerances:
 - a. 60 Hertz
 - Nameplate 208V: Min. 187V, Max. 229V
 - Nameplate 230V: Min. 207V, Max. 253V
 - Nameplate 460V: Min. 414V, Max. 506V
 - Nameplate 575V: Min. 518V, Max. 633V
2. Minimum Circuit Ampacity (MCA) Calculation is based on the following formulas:

Unit Sizes 006-050:
Unit MCA = 1.25 (heater FLA + motor loads)

Unit Sizes 060-100*:
Unit MCA = 1.25 (motor loads + transformer load)

*Electric heat equipped units have dual-source power and MCA/MROPD is calculated separately.

Electric Heat Section MCA = 1.25 x heater FLA
3. MROPD is calculated per UL 1995 methodology.
4. Size wires in accordance with Table 310-16 or 310-19 of the National Electrical Code.
5. Wires should be sized for a maximum of 3% voltage drop.

Electrical Installation

1. Electrical service to the fan must correspond to the rated voltage on the motor nameplate and be in conformance with the National Electric Code and local restrictions.
2. The unit metal frame must be connected to the building electrical ground and all wiring must be in conformance with the national electric code and local restrictions.

NOTICE

All field wiring penetrations, for both power and controls wiring, must only be made at the factory designated locations on the top, side, or bottom panels. These locations are identified on the panels with a 3/16" pilot hole, and are shown in the following drawings.

3. To make a field wiring connection, use a hole saw to penetrate the double wall panel at the designated locations and install up to a 1" electrical conduit bulkhead connector as shown below. Route the power wires through the conduit connector to the disconnect box and the wire to the control box inside the cabinet.
4. All units are provided with a safety disconnect switch. Unit sizes 006 – 020 are available as single phase only and are provided with a two pole switch. Three phase units, unit sizes 030 – 050, are provided with a three pole switch.
5. Optional factory provided over current protection is available on all units with a maximum operating current less than or equal to 48 amps. This protection is provided with fuses located on the unit main power circuit. Units with a maximum operating current greater than 48 amps are provided with factory installed fusing on the electric heat circuit only.
6. All field provided controllers must be powered by the unit transformer.
7. All grounds, both AC and DC, are to be consolidated at the unit.
8. A DC common input is not included on the unit. Accordingly, the AC ground and DC ground are the same. Any field provided controller must be compatible with this.

Electric Heat Control

1. Electric heat control can be factory configured for either on-off or analog control.
2. On-off control requires a 24VAC signal applied to terminal EH 24+ to cycle the electric heat elements.
3. Analog control uses an SCR control module to power the electric elements and requires a 0-10VDC signal applied to terminal EH 0-10V, to modulate heat output.

Valve Control

1. Valve control can be factory configured for either on-off or analog control.
2. On-off control requires a 24VAC signal applied to terminal VLV1 24+ or VLV2 24+ to control the valve.
3. Analog control requires a 0-10VDC signal, applied to terminal VLV1 0-10V or VLV2 0-10V to modulate the valve.

Motor Controls

1. Unit sizes 006 – 020 ship with an EC motor factory configured for either three speed or analog control.
2. The three speed control option provides three separate field adjustable motor speeds that can be activated by applying a 24VAC signal to the appropriate terminal. This allows fan control with a conventional three position fan switch or fan coil style thermostat. The speed terminals in the unit, CALL 1, CALL 2, and CALL 3 correspond to the low, medium and high speed terminals on the switch. Speed adjustment is made at the EVO board by turning the dial adjacent to the speed terminal to change the motor's RPM for that speed.

- The analog speed control option requires a 0-10VDC signal applied to terminal FAN 0-10V on terminal block TB4 to control motor RPM. 0.0VDC turns the fan off. 1.0VDC is the threshold for turning on the fan and induces the minimum motor RPM. 10.0VDC runs the motor at maximum RPM.

NOTICE

Design may call for lower than a 10VDC max signal.

- Unit sizes 030 – 050 are provided with a factory installed VFD programmed for analog motor speed control. A 0-10VDC signal applied to terminal FAN 0-10V on terminal block TB4 allows motor RPM to be adjusted. VFD settings are programmed at the factory, with motor information inputted.

Damper Control

- Damper control can be factory configured for either on-off or analog control.
- On-off control requires a 24VAC signal applied to terminal ACT 24+ to cycle the damper.
- Analog control requires a 0-10VDC signal applied to terminal ACT 0-10V to modulate the damper.

Field Control Wiring**⚠ DANGER**

LOCKOUT/TAGOUT all power sources prior to wiring or servicing the unit. Electrical shock hazard that may cause severe injury or death. Connect only low voltage NEC Class II circuits to terminal blocks TB2, TB3, TB4, TB5, and TB12. Reinstall and secure all protective front panels when the wiring installation is complete.

PreciseLine units are available with several control schemes which may require low voltage field wiring. Use the Unit Specific Electrical Schematics to determine which control connections will be required for installation. Check unit specific electrical documentation in the door of the control panel. [Table 29](#) and [Table 30](#) show the possible field connections that can be made.

NOTICE

Possible field connections listed have no effect on unit function unless a factory installed controller or a field installed controller with the necessary controls logic is used with the unit.

PreciseLine units operate with 115V and 24V control circuit power. All field control wiring connections are made at the class II terminal blocks TB2, TB4, and TB12 which is located in the Low Voltage Control Panel.

NOTICE

The installation of all field wiring, must comply with all applicable local codes and ordinances. The warranty may be limited or certain aspects excluded if the field wiring is not in accordance with these standards.

If a single conduit containing 24V and 115V wiring is run above the roofline between units, consider the 24V wiring within as an NEC Class I wiring system.

Emergency Stop

The terminals TB12-T10 & TB2-Ground on unit sizes 006-050 and TB2/TB3-299 & TB2/TB3-236 on unit sizes 060-100 can be used for any field supplied component that requires a unit emergency stop. When these terminals are used, the factory installed jumper must be removed.

A2L Leak Detection (Unit Sizes 006-050)

On all units with A2L refrigerant coils, the terminals TB5-A2LR1COM & TB5-A2LR1SIG are intended to provide indication of an A2L refrigerant leak. The terminals will be a closed circuit under normal operating conditions. These terminals will open when an A2L refrigerant leak is detected. 24VAC or Ground can be connected to TB5-A2LR1CF depending on the type required to provide indication of an A2L refrigerant leak.

A2L Sensor Problem (Unit Sizes 006-050)

On units with A2L refrigerant coils and DDC ready controls option, the terminals TB5-A2LR2COM & TB5-A2LR2SIG are intended to provide indication of an A2L refrigerant sensor problem. The terminals will be a closed circuit under normal operating conditions. These terminals will open when an A2L refrigerant sensor problem is detected. 24VAC or Ground can be connected to TB5-A2LR2 COM depending on the type required to provide indication of an A2L refrigerant sensor problem.

A2L Leak Detection (Unit Sizes 060-100)

On all units with A2L refrigerant coils, the terminals TB2/3-310, 311, and 312 are intended to provide indication of an A2L refrigerant leak. The terminals 310 and 312 will be a closed circuit and terminals 310 and 311 will be an open circuit under normal operating conditions. The terminals 310 and 312 will be an open circuit and terminals 310 and 311 will be a closed circuit when an A2L refrigerant leak is detected. 24VAC or Ground can be connected to terminal 310 depending on the type required to provide indication of an A2L refrigerant leak.

A2L Sensor Problem (Unit Sizes 060-100)

On units with A2L refrigerant coils and DDC ready controls option, the terminals TB2/3-313, 314, and 315 are intended to provide indication of an A2L refrigerant sensor problem. The terminals 313 and 315 will be a closed circuit and terminals 313 and 314 will be an open circuit under normal operating conditions. The terminals 313 and 315 will be an open circuit and terminals 313 and 314 will be a closed circuit when an A2L refrigerant sensor problem is detected. 24VAC or Ground can be connected to terminal 313 depending on the type required to provide indication of an A2L refrigerant sensor problem.

**Table 29: Potential Field Connections and Locations
(Unit Sizes 006-050)**

	Label	Description	Signal
TB12	T1	Freezestat	24VAC Contact Closure
	T2	Condensate Overflow	Discrete Contact Closure
	T3	Space Humidity Sensor	0-10 VDC Input
	T4	Compressor 2	24VAC Output
	T5	Discharge Air Temperature	Thermistor Input
	T6	Airflow Switch	24VAC Contact Closure
	T7	Entering Water Temp / Leaving Coil Temp	Thermistor Input
	T8	Duct Static Pressure	0-10 VDC Input
	T9	Duct Static Pressure Power	24 VDC Supply
	T10	Emergency Stop	Discrete Contact Closure
	T11	Remote Space Sensor (CE-)	Remote Space Sensor Communications (CE-)
	T12	Remote Space Sensor (CE+)	Remote Space Sensor Communications (CE+)
TB5	A2LR1 CF	A2L Leak Signal Common	Output Common
	A2LR1 NO	A2L Leak Signal Normally Open	24VAC or Discrete Output
	A2LR2 CF	A2L Sensor Error Signal Common	Output Common
	A2LR2 NO	A2L Sensor Error Normally Open	24VAC or Discrete Output
TB4	T1	Supply Fan Signal	0-10 VDC Output
	T2	Compressor 1 or Valve 1	24VAC Output / 0-10 VDC Output
	T3	Electric Heat or Valve 2	24VAC Output / 0-10 VDC Output
	T4	Outside Air Damper	0-10 VDC Output
TB2	24+	Supply Voltage	24VAC Output Supply
	Common	Supply Voltage Common	Ground

NOTE: Possible field connections listed have no effect on unit function unless a factory installed controller or a field installed controller with the necessary controls logic is used with the unit.

**Table 30: Potential Field Connections and Locations
(Unit Sizes 060-100)**

	Label	Description	Signal
TB2 or TB3	24V	Supply Voltage	24VAC Output Supply
	N24	Supply Voltage Common	Ground
	236	Sensor Common	Sensor Common
	+24V	Sensor Power MCB	24VDC Supply MCB
	+24V-A	Sensor Power EXP-A	24VDC Supply EXP-A
	202	Condensate Overflow Switch	Discrete Contact Closure
	208	Outdoor Air Humidity	0-10VDC Input
	208E	Space Humidity Sensor	0-10VDC Input
	208G	Return Air Humidity Sensor	0-10VDC Input
	210	Remote Integrated Thermostat	CTX
	212	Remote Integrated Thermostat	CTX
	213	Space CO2	0-10VDC Input
	220	Freeze Stat	24VAC Contact Closure
	222	SCR Electric Heat/Electric Heat Stage 1	0-10VDC Output/24VAC Output
	223	Electric Heat Stage 2	24VAC Output
	224	Electric Heat Stage 3	24VAC Output
	225	Electric Heat Stage 4	24VAC Output
	228C	Hot Water Valve Output	24VAC Output
	232A	Main Dirty Filter Switch	Discrete Contact Closure
	247	Entering Water Temp/Leaving Coil Temp	Thermistor Input

	Label	Description	Signal
TB2 or TB3	249	Compressor 1/Vlv1 On Off/Chilled Water Vlv	24VAC Output
	251	Compressor 2	24VAC Output
	254	Compressor 3	24VAC Output
	256	Compressor 4	24VAC Output
	267	Supply Fan Signal	0-10VDC Output
	275	Exhaust Fan Signal	0-10VDC Output
	277	Outdoor Air Damper	0-10VDC Output
	281	Discharge Air Temp	Thermistor Input
	282	Return Air Temp	Thermistor Input
	297	Outdoor Air Temp	Thermistor Input
	299	Emergency Stop	Discrete Contact Closure
	2120	Air Flow Switch	24VAC Contact Closure
	2124	Duct Static Pressure	0-10VDC Input
	2130	Damper End Switch	Discrete Contact Closure
	2133	Return Air Damper	0-10VDC Output
	2140	VAV Box Output	24VAC Output
	2150	Mod Chilled Water Vlv/Mod Changeover Vlv	0-10VDC Output
	222	Modulating Hot Water Valve Output	0-10VDC Output
	302	Energy Recovery/OA Filter Switch	Discrete Contact Closure
	306	Energy Recovery Wheel On/Off	24VAC Output
	305	Bypass Damper CCW (Bypass)	24VAC Output
	301	Bypass Damper CW (Not Bypass)	24VAC Output
	300	Defrost 2 Position HW Valve	24VAC Output
	300	Defrost Electric Heat Stage 1	24VAC Output
	308	Supply Air Leaving Wheel Temperature (ER_LWT)	Thermistor Input
	309	Exhaust Air Exiting Wheel Temperature (ER_EWT)	Thermistor Input
	307	Energy Recovery Wheel Rotation Switch	Discrete Contact Closure
	303	Defrost Modulating Heating Valve	0-10VDC Output
	303	Defrost SCR Electric Heat	0-10VDC Output
	304	ERW VFD	0-10VDC Output
	310	A2L Leak Signal Common	Output Common
	311	A2L Leak Signal Normally Closed	24VAC or Discrete Output
	312	A2L Leak Signal Normally Open	24VAC or Discrete Output
	313	A2L Sensor Error Signal Common	Output Common
	314	A2L Sensor Error Normally Closed	24VAC or Discrete Output
315	A2L Sensor Error Normally Open	24VAC or Discrete Output	
GND	Main Unit Ground	Ground	

NOTE 1: TB2 is for horizontal units. TB3 is for vertical units.

NOTE 2: If Daikin Applied is not providing a controller, Sensor Common is wired to Main Unit Ground with WIRE-123A. If field-installed controls require a different ground, this wire may need to be removed (if present).

NOTE 3: Possible field connections listed have no effect on unit function unless a factory installed controller or a field installed controller with the necessary controls logic is used with the unit.

Example Wiring Diagrams

Figure 23: 3 Phase Power, SCR Electric Heat, No Valve, Modulating Damper, VFD Fan

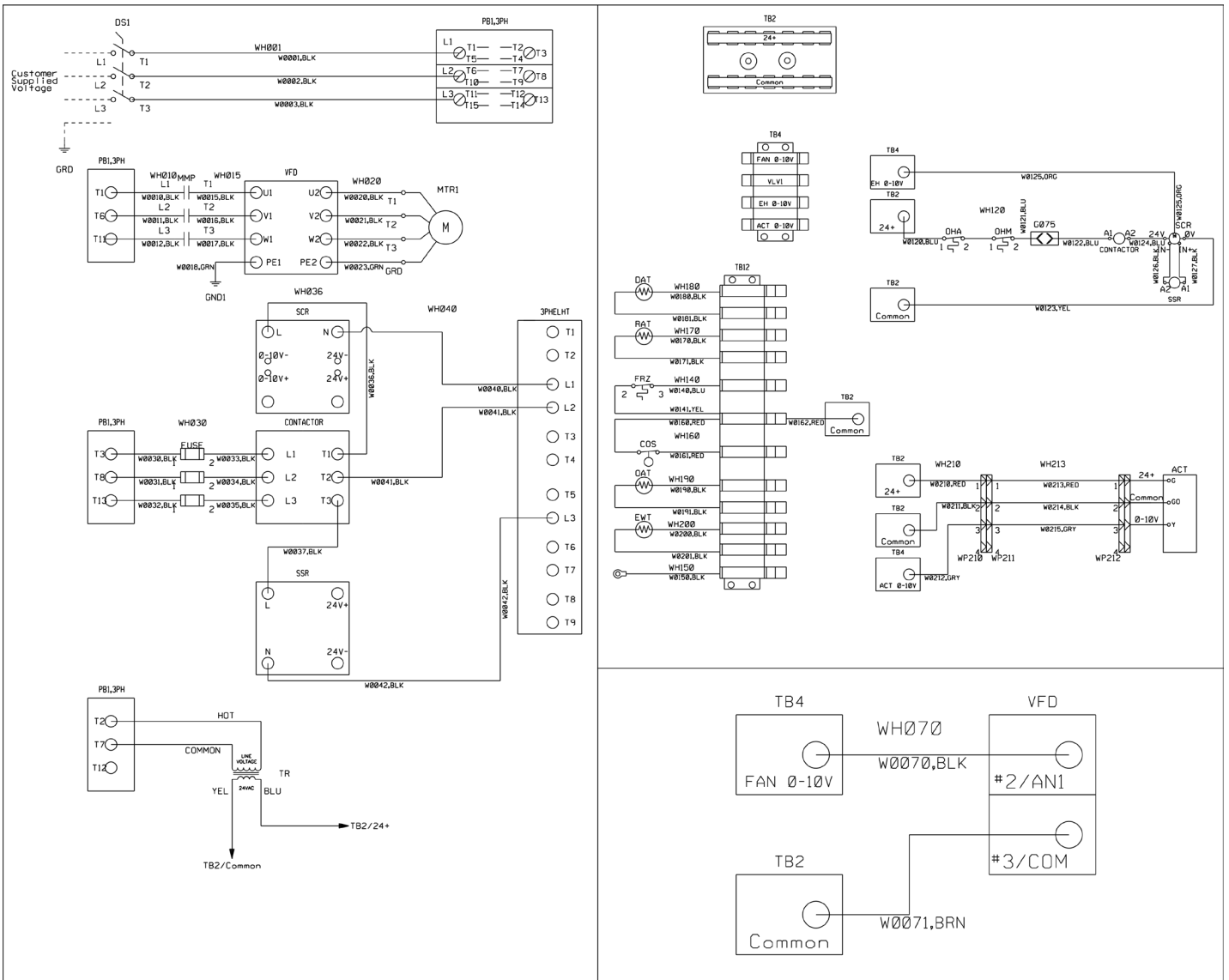

Figure 25: 1 Phase Power, On-Off Electric Heat, On-Off Valve, On-Off Damper, 3-Speed Fan

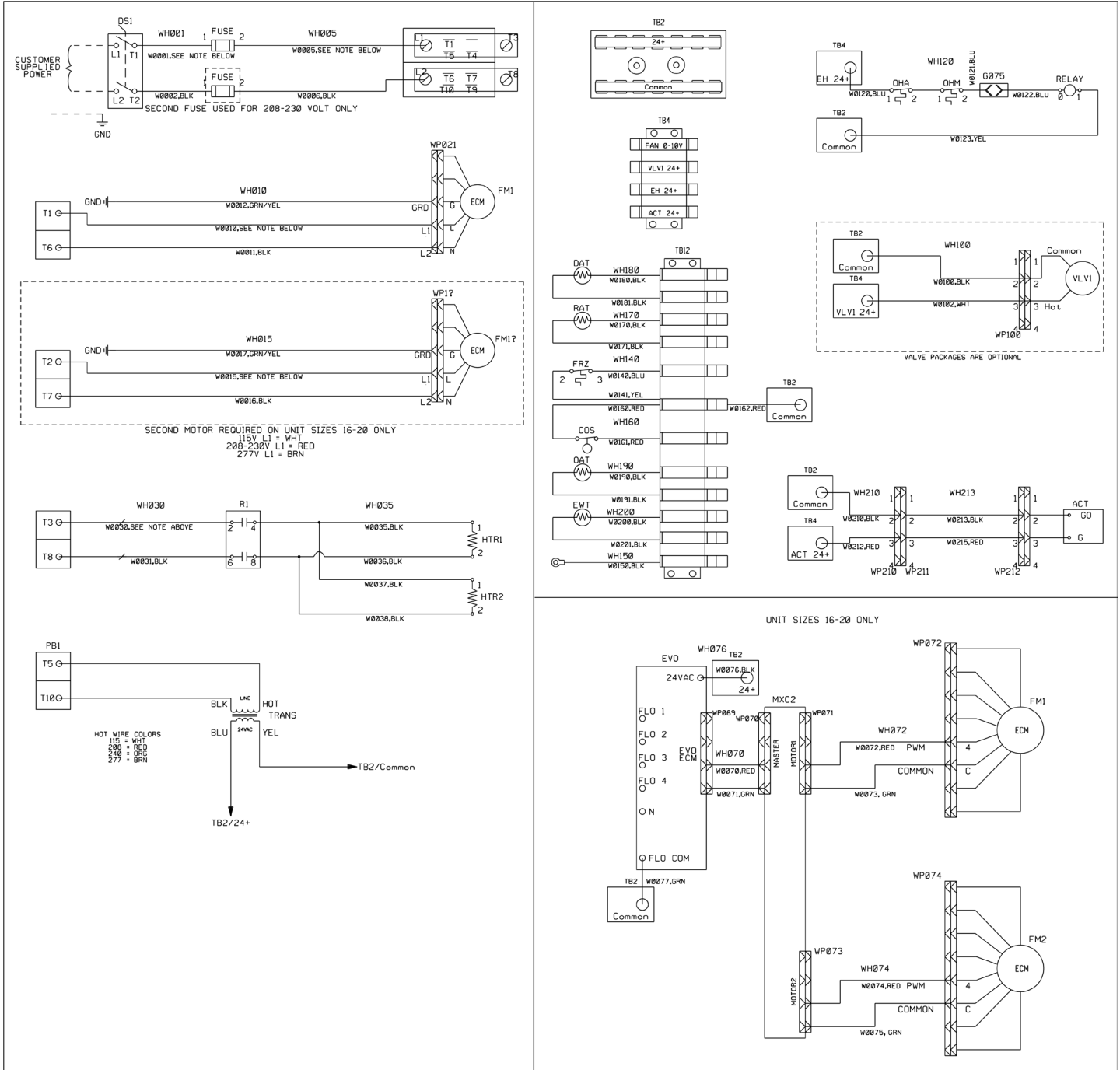

Figure 26: 3-Phase Power, Welded Aluminum Airfoil Plenum Fan, On-Off Electric Heat, On/Off Damper, Fused with MicroTech Controller for Unit Sizes 006-050

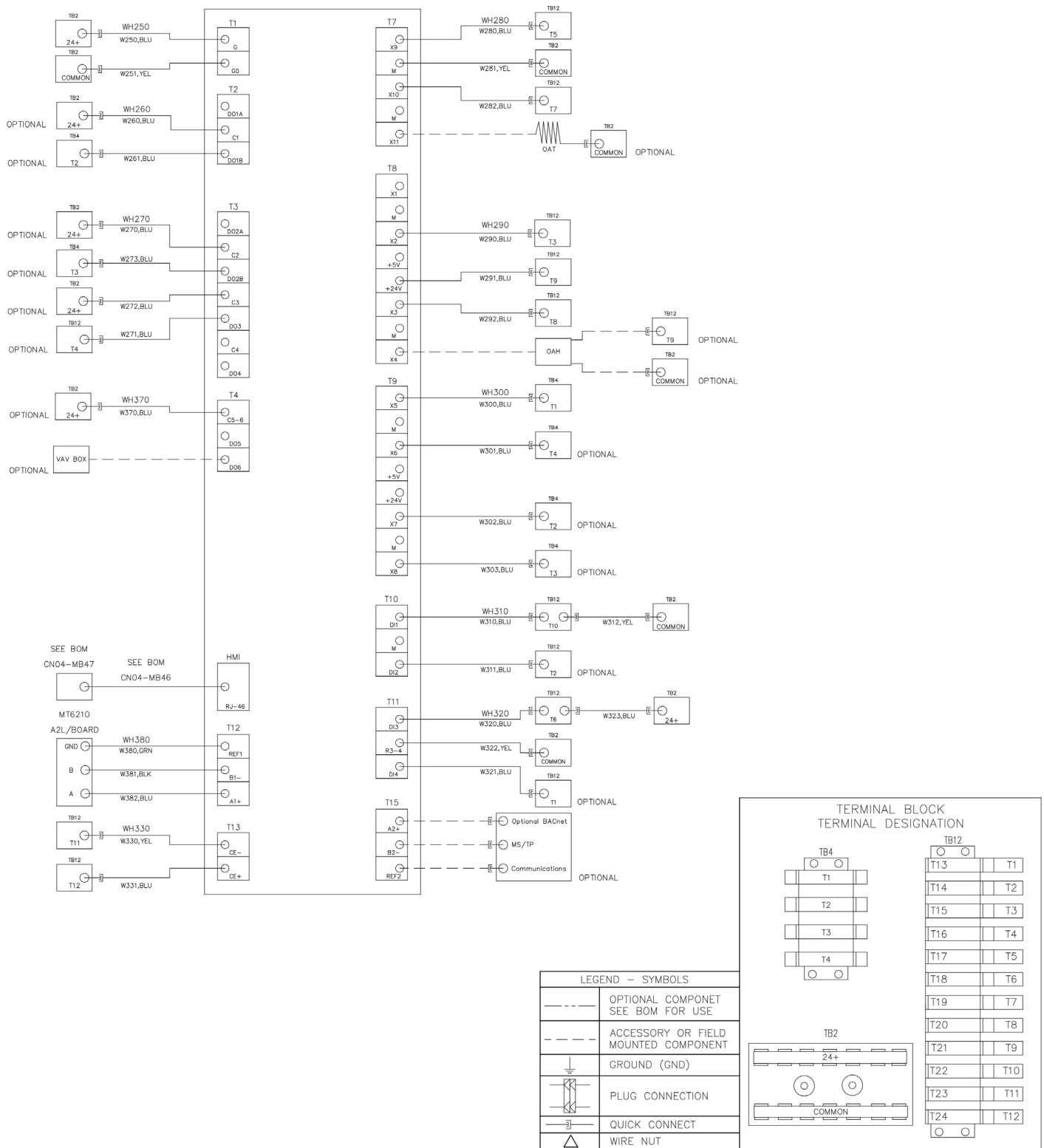

Figure 28: MicroTech Controller for Unit Sizes 060-100 with Optional Energy Recovery Wheel

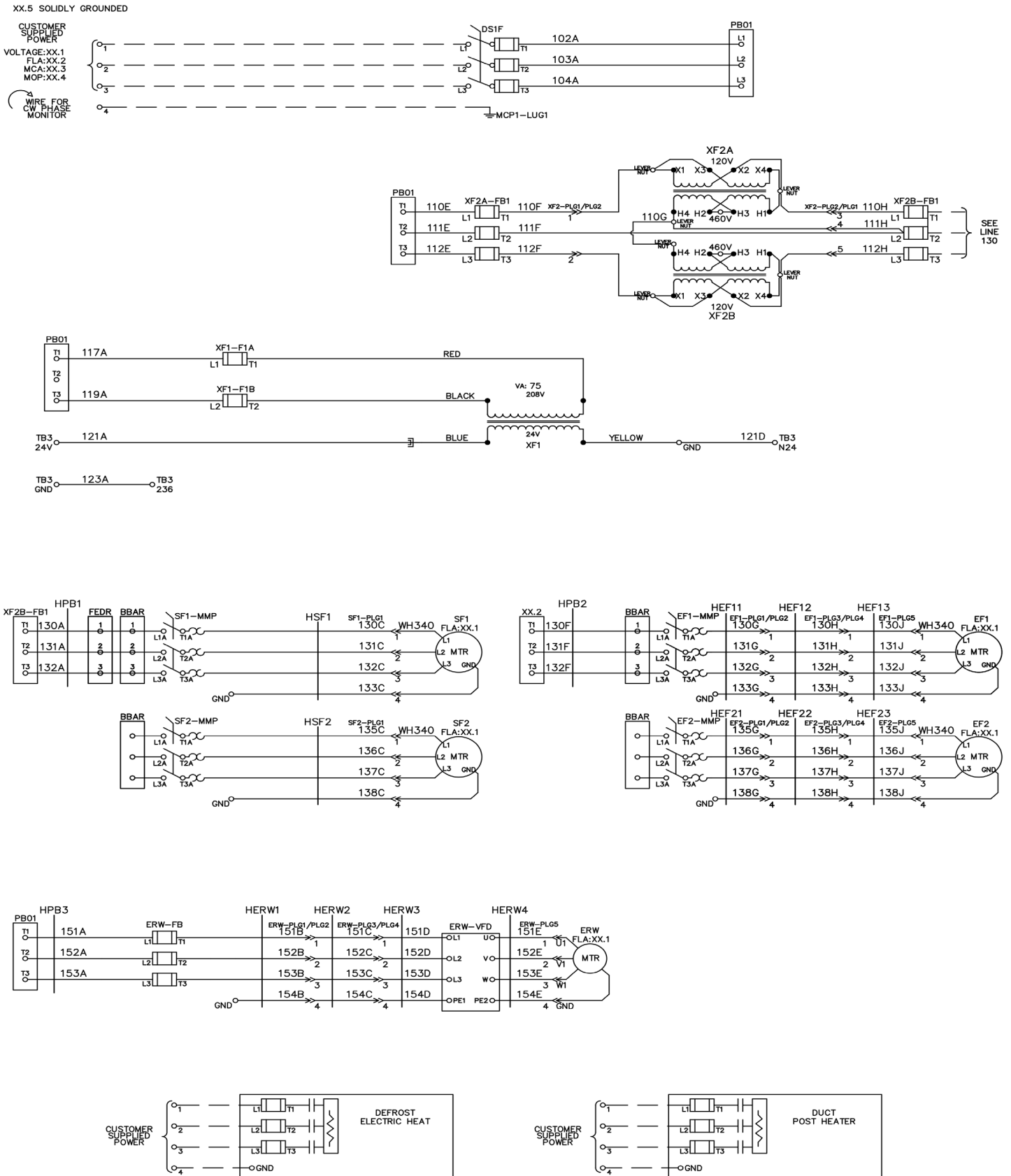

Figure 29: MicroTech Controller for Unit Sizes 060-100 with Optional Energy Recovery Wheel

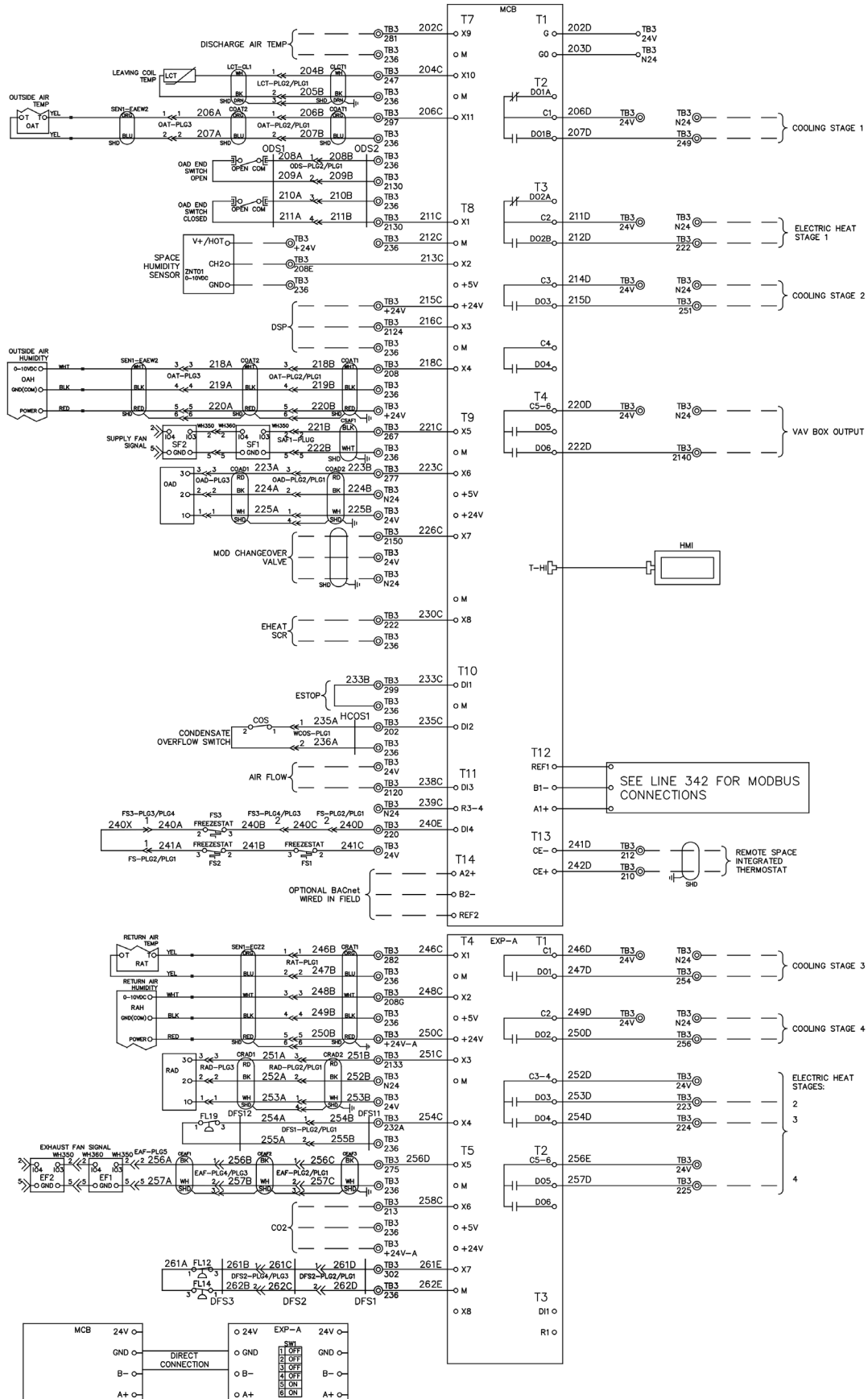
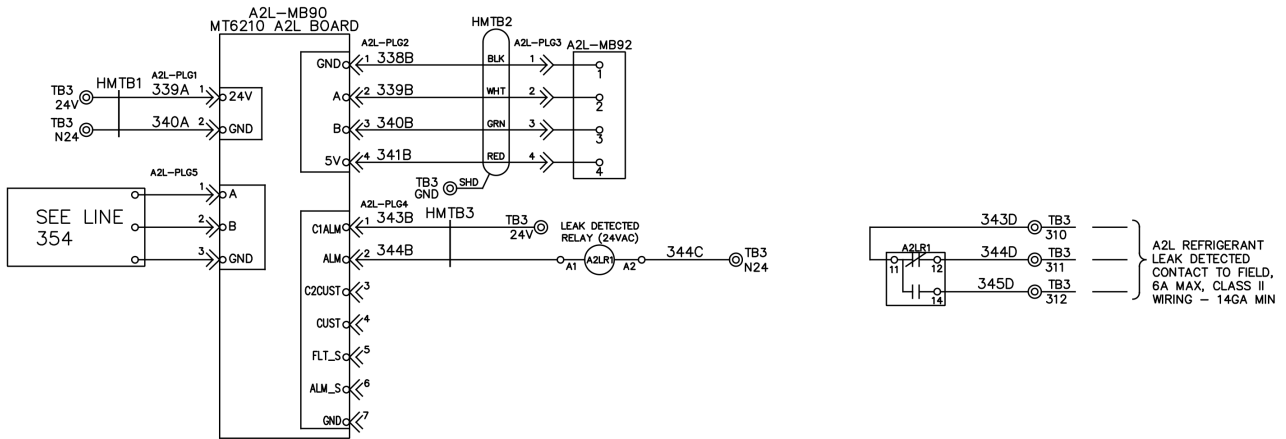
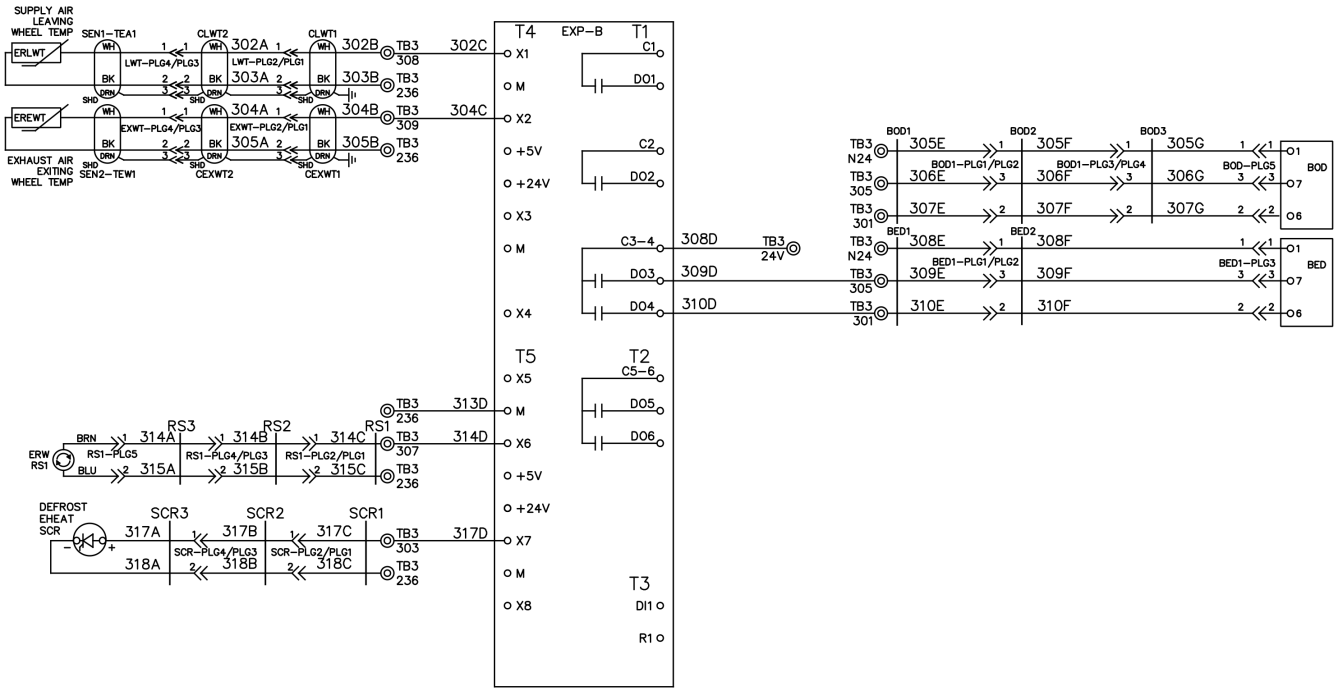
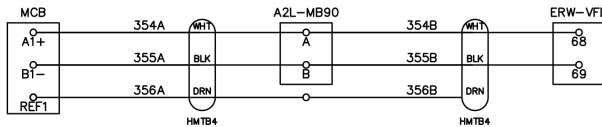

Figure 30: MicroTech Controller for Unit Sizes 060-100 with Optional Energy Recovery Wheel & A2L Controller



NOTE: SPLICE DRAINS TOGETHER BUT ONLY TERMINATE ON MCB



MODBUS ADDRESSES

- MCB1 : 01
- A2L : 09
- ERW : 41

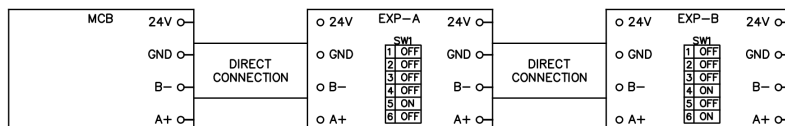

Wiring Schematics Legend for “Example Wiring Diagrams”

LEGEND			
A2L	Leak Detection Control Board	OAT	Outside Air Temperature Sensor
A2LR1-2	A2L Relays	OHA	Automatic High Temp Cutout Switch
ACT	Mixing Box Damper Actuator	OHM	Manual High Temp Cutout Switch
BBSF-EF	BusBar Supply-Exhaust	PB1	Main Power Distribution Block
BED	Bypass Exhaust Air Damper	PB2	Electric Heat Power Distribution Block
BOD	Bypass Outside Air Damper	PB3	24VAC Power Distribution Block
C500	MicroTech 4 Lite Controller	R1-2	Electric Heater Power Relay
CON	Energy Wheel Motor Contactor	R3	Electric Heater Control Relay
COS	Condensate Overflow Switch/Sensor	RAD	Return Air Damper
DAT	Discharge Air Temperature Sensor	RAT	Return Air Temperature Sensor
DS	Disconnect Switch	RS1	Rotational Switch
EB	MicroTech I/O Expansion Board	SF1-2	Supply Fan Motor
EF1-3	Exhaust Fan Motor	TB2-3	24VAC Terminal Block
ERW	Energy Recovery Wheel	TB4	EC Motor Control Terminal Block
EWT	Entering Water Temperature	TB5	A2L Terminal Block
EXP-A	MicroTech I/O Expansion Board	TB6	No Controls Terminal Block
EXP-B	MicroTech I/O Expansion Board	TB12	Sensor & Control Signals Terminal Block
FM1-2	Fan Motor	TR	Control Transformer
FLxx	Dirty Filter Switch	TS1-2	Thermal Switch (Intermediate Electric Heat)
FRZ	Freeze Alarm Switch	TS3	Thermal Switch (Automatic Change Over)
FS1-3	Freeze Alarm Switch	VSV1-2	Coil Valve Actuator (Primary or Secondary)
FSW	Fan 3-Speed Switch	WHxxx	Wire Harness
G075	Quick Connect Splice	WNxxx	Wire Nut
HTR1-4	Electric Heater Elements	WPxxx	Wire Plug
LVB	Low Voltage Control Board	Wxxx	Wire
MCB	Main Control Board (C500)	XF1	Control Transformer
NCB	Network Communication Board	XF2A-B	Buck Boost Transformers
OAD	Outside Air Damper		

NOTE 1: Devices may or may not be on unit.

NOTE 2: Wiring diagrams are typical, always defer to the wiring diagram provided with the unit.

Hot Wire Colors

115V = WHT
 208V = RED
 240V = ORG
 277V = BRN
 480V = BLK/RED
 575V = BLK

MMP/Fuse

575V = Fuse
 208/240/480V = MMP

Physical Data Tables

Component Weights

Table 31: Horizontal Component Weights (Unit Sizes 006-050)

Component	Rows	FPI	Weight — lbs (kg)									
			006	008	010	012	016	018	020	030	040	050
Coil (Wet)	1	12	6 (3)	7 (4)	9 (5)	9 (5)	10 (5)	11 (5)	11 (5)	20 (10)	26 (12)	33 (15)
	1	16	7 (4)	7 (4)	9 (5)	9 (5)	11 (5)	12 (6)	12 (6)	21 (10)	28 (13)	35 (16)
	2	12	9 (5)	10 (5)	13 (6)	13 (6)	17 (8)	19 (9)	19 (9)	33 (15)	43 (20)	53 (25)
	2	16	9 (5)	11 (5)	14 (7)	14 (7)	18 (9)	21 (10)	21 (10)	36 (17)	46 (21)	57 (26)
	4	12	13 (6)	16 (8)	23 (11)	23 (11)	28(13)	35 (16)	35 (16)	57 (26)	77 (35)	93 (43)
	4	16	14 (7)	17 (8)	24 (11)	24 (11)	30 (14)	38 (18)	38 (18)	61 (28)	84 (39)	101 (46)
	6	12	18 (9)	23 (11)	31 (15)	31 (15)	41 (19)	49 (23)	49 (23)	78 (36)	106 (49)	128 (59)
	6	16	19 (9)	25 (12)	34 (16)	34 (16)	44 (20)	54 (25)	54 (25)	85 (39)	115 (53)	140 (64)
	8	12	-	-	-	-	-	-	-	100 (46)	134 (61)	164 (75)
8	16	-	-	-	-	-	-	-	109 (50)	147 (67)	179 (82)	
Coil (Dry)	1	12	5 (3)	6 (3)	7 (4)	7 (4)	8 (4)	9(5)	9(5)	16 (8)	20 (10)	25 (12)
	1	16	5 (3)	6 (3)	7 (4)	7 (4)	8 (4)	10 (5)	10 (5)	17 (8)	22 (10)	27 (13)
	2	12	7 (4)	8 (4)	10 (5)	10 (5)	12 (6)	14 (7)	14 (7)	24 (11)	32 (15)	39 (18)
	2	16	7 (4)	8 (4)	11 (5)	11 (5)	14 (7)	16 (8)	16 (8)	27 (13)	35 (16)	43 (20)
	4	12	10 (5)	12 (6)	16 (8)	16 (8)	20 (10)	25 (12)	25 (12)	41 (19)	55 (25)	65 (30)
	4	16	11 (5)	13 (6)	18 (9)	18 (9)	23 (11)	28 (13)	28 (13)	46 (21)	61 (28)	73 (34)
	6	12	13 (6)	16 (8)	23 (11)	23 (11)	29 (14)	35 (16)	35 (16)	56 (26)	75 (35)	91 (42)
	6	16	14 (7)	18 (9)	25 (12)	25 (12)	33 (15)	40 (19)	40 (19)	63 (29)	84 (39)	102 (47)
	8	12	-	-	-	-	-	-	-	72 (33)	95 (44)	116 (53)
8	16	-	-	-	-	-	-	-	81 (37)	107 (49)	131 (60)	
DX Normal	3	12	9(5)	11 (5)	15 (7)	15 (7)	19 (9)	23 (11)	23 (11)	38 (18)	49 (23)	60 (28)
	3	16	10 (5)	12 (6)	17 (8)	17 (8)	21 (10)	25 (12)	25 (12)	42 (20)	54 (25)	66 (30)
DX Interlaced	3	12	-	-	-	-	-	-	-	36 (17)	47 (22)	58 (27)
	3	16	-	-	-	-	-	-	-	40 (19)	52 (24)	64 (30)
Standard Cabinet (FC Fans)	-	-	180 (82)	260 (118)	324 (147)	324 (147)	440 (200)	530 (241)	530 (241)	490 (223)	585 (266)	730 (332)
Standard Cabinet (Plenum Fans)	-	-	-	-	-	-	-	-	-	457 (208)	618 (281)	743 (338)
Mixing Box	-	-	22 (10)	32 (15)	40 (18)	40 (18)	54 (25)	54 (25)	65 (30)	68 (31)	72 (33)	90 (41)
Discharge Plenum	-	-	20 (9)	29 (13)	36 (16)	36 (16)	49 (22)	49 (22)	59 (27)	63 (29)	67 (30)	81 (37)
Primary Valve Package	-	-	6 (3)	6 (3)	9 (4)	9 (4)	10 (5)	12 (5)	12 (5)	-	-	-
Heating Valve Package	-	-	4 (2)	4 (2)	6 (3)	6 (3)	6 (3)	8 (4)	8 (4)	-	-	-
VRV	3	12	9 (5)	11 (5)	15 (7)	15 (7)	18 (9)	22(10)	22 (10)	-	47 (22)	58 (27)
	3	10	-	-	-	-	-	-	-	36 (16)	-	-

Table 32: Horizontal Component Weights (Unit Sizes 060-100)

Component	Rows	FPI	Weight — lbs (kg)		
			060	080	100
Coil (Wet)	1	12	40 (18)	52 (24)	66 (30)
	1	16	42 (19)	56 (25)	70 (32)
	2	12	66 (30)	86 (39)	106 (48)
	2	16	72 (33)	92 (42)	114 (52)
	4	12	114 (52)	154 (70)	186 (84)
	4	16	122 (55)	168 (76)	20 (9)
	6	12	156 (71)	20 (9)	24 (11)
	6	16	170 (77)	22 (10)	28 (13)
	8	12	20 (9)	26 (12)	32 (15)
Coil (Dry)	8	16	20 (9)	28 (13)	34 (15)
	1	12	32 (15)	40 (18)	50 (23)
	1	16	34 (15)	44 (20)	54 (24)
	2	12	48 (22)	64 (29)	78 (35)
	2	16	54 (24)	70 (32)	86 (39)
	4	12	82 (37)	110 (50)	130 (59)
	4	16	92 (42)	122 (55)	146 (66)
	6	12	112 (51)	150 (68)	182 (83)
	6	16	126 (57)	168 (76)	20 (9)
DX Normal	8	12	144 (65)	190 (86)	22 (10)
	8	16	162 (73)	20 (9)	26 (12)
DX Interlaced	3	12	76 (34)	98 (44)	120 (54)
	3	16	84 (38)	108 (49)	132 (60)
VRV	3	12	-	94 (43)	116 (53)
	3	10	72 (33)	-	-
Discharge Plenum	-	-	207 (94)	209 (95)	240 (109)
Discharge Plenum with Post Filter	-	-	342 (155)	385 (175)	428 (194)
Fan Section	-	-	325 (147)	383 (174)	415 (188)
Single Supply Fan Weight	-	-	110 (50)	110 (50)	110 (50)
Dual Supply Fan Weight	-	-	220 (100)	220 (100)	220 (100)
Coil Section	-	-	246 (112)	251 (114)	293 (133)
Prefilter	-	-	248 (112)	281 (127)	309 (140)
Mixbox	-	-	435 (197)	477 (216)	527 (239)
Economizer	-	-	448 (203)	492 (223)	526 (239)
Electric Heat	-	-	275 (125)	284 (129)	289 (131)
Exhaust Air/Outdoor Air	-	-	250 (113)	245 (111)	290 (132)
Single Supply Fan	-	-	20 (9)	20 (9)	-
Dual Supply Fans	-	-	-	40 (18)	40 (18)
Triple Supply Fans	-	-	-	60 (27)	60 (27)

Table 33: Vertical Component Weights (Unit Sizes 006-050)

Component	Rows	FPI	Weight—lbs (kg)							
			006	008	012	016	020	030	040	050
Coil (Wet)	1	12	6 (3)	8 (4)	9 (5)	12 (6)	13 (6)	22 (10)	28 (13)	38 (18)
	1	14	7 (4)	8 (4)	10 (5)	12 (6)	13 (6)	22 (10)	29 (14)	39 (18)
	1	16	7 (4)	8 (4)	10 (5)	12 (6)	14 (7)	23 (11)	30 (14)	40 (19)
	2	12	10 (5)	11 (5)	14 (7)	19 (9)	21 (10)	36 (17)	47 (22)	59 (27)
	2	14	10 (5)	11 (5)	14 (7)	19 (9)	22 (10)	37 (17)	48 (22)	61 (28)
	2	16	10 (5)	11 (5)	15 (7)	20 (10)	23 (11)	39 (18)	50 (23)	63 (29)
	4	12	13 (6)	17 (8)	23 (11)	30 (14)	37 (17)	61 (28)	80 (37)	101 (46)
	4	14	14 (7)	17 (8)	24 (11)	32 (15)	39 (18)	63 (29)	83 (38)	105 (48)
	4	16	14 (7)	18 (9)	25 (12)	33 (15)	40 (19)	65 (30)	86 (40)	109 (50)
	6	12	18 (9)	23 (11)	32 (15)	44 (20)	52 (24)	87 (40)	109 (50)	138 (63)
	6	14	18 (9)	24 (11)	33 (15)	45 (21)	54 (25)	90 (41)	113 (52)	143 (65)
	6	16	19 (9)	25 (12)	34 (16)	47 (22)	56 (26)	94 (43)	118 (54)	149 (68)
	8	12	-	-	-	-	-	109 (50)	137 (63)	174 (79)
	8	14	-	-	-	-	-	114 (52)	143 (65)	181 (83)
8	16	-	-	-	-	-	119 (54)	150 (69)	189 (86)	
Coil (Dry)	1	12	5 (3)	6 (3)	7 (4)	9 (5)	10 (5)	17 (8)	22 (10)	29 (14)
	1	14	5 (3)	6 (3)	8 (4)	9 (5)	10 (5)	18 (9)	23 (11)	30 (14)
	1	16	5 (3)	6 (3)	8 (4)	10 (5)	11 (5)	19 (9)	24 (11)	31 (15)
	2	12	7 (4)	8 (4)	10 (5)	14 (7)	16 (8)	27 (13)	35 (16)	44 (20)
	2	14	8 (4)	9 (5)	11 (5)	15 (7)	17 (8)	28 (13)	36 (17)	46 (21)
	2	16	8 (4)	9 (5)	11 (5)	15 (7)	17 (8)	30 (14)	38 (18)	48 (22)
	4	12	10 (5)	12 (6)	17 (8)	22 (10)	27 (13)	44 (20)	56 (26)	71 (33)
	4	14	10 (5)	13 (6)	18 (9)	23 (11)	28 (13)	46 (21)	59 (27)	75 (35)
	4	16	11 (5)	14 (7)	19 (9)	25 (12)	30 (14)	49 (23)	63 (29)	79 (36)
	6	12	13 (6)	17 (8)	23 (11)	31 (15)	37 (17)	61 (28)	77 (35)	97 (44)
	6	14	14 (7)	18 (9)	24 (11)	33 (15)	39 (18)	65 (30)	81 (37)	103 (47)
	6	16	14 (7)	19 (9)	25 (12)	35 (16)	42 (20)	68 (31)	86 (40)	109 (50)
	8	12	-	-	-	-	-	77 (35)	97 (44)	122 (56)
	8	14	-	-	-	-	-	82 (38)	103 (47)	130 (59)
8	16	-	-	-	-	-	86 (40)	109 (50)	138 (63)	
DX Normal	3	12	9 (5)	11 (5)	15 (7)	20 (10)	24 (11)	-	-	-
	3	14	9 (5)	12 (6)	16 (8)	21 (10)	25 (12)	-	-	-
	3	16	9 (5)	12 (6)	17 (8)	22 (10)	26 (12)	-	-	-
	6	12	14 (7)	19 (9)	26 (12)	35 (16)	42 (20)	67 (31)	85 (39)	107 (49)
	6	14	15 (7)	20 (10)	27 (13)	37 (17)	44 (20)	71 (33)	90 (41)	113 (52)
	6	16	16 (8)	21 (10)	28 (13)	39 (18)	47 (22)	74 (34)	94 (43)	119 (54)
DX Interlaced	3	12	-	-	-	-	-	36 (17)	48 (22)	60 (28)
	3	14	-	-	-	-	-	38 (18)	50 (23)	63 (29)
	3	16	-	-	-	-	-	40 (19)	52 (24)	66 (30)
	6	12	-	-	-	-	-	64 (30)	84 (39)	107 (49)
	6	14	-	-	-	-	-	68 (31)	89 (41)	113 (52)
	6	16	-	-	-	-	-	71 (33)	93 (43)	119 (54)
Standard Cabinet (FC Fans)	-	-	119 (54)	119 (54)	119 (54)	170 (78)	170 (78)	315 (143)	336 (153)	373 (170)
Standard Cabinet (Plenum Fans)	-	-	-	-	-	-	-	272 (124)	332 (151)	340 (155)
Mixing Box	-	-	-	-	-	-	-	88 (40)	97 (44)	105 (48)
Discharge Plenum	-	-	20 (10)	23 (11)	25 (12)	33 (15)	35 (16)	48 (22)	52 (24)	56 (26)
Primary Valve Package	-	-	6 (3)	6 (3)	9 (4)	10 (5)	12 (5)	-	-	-
Heating Valve Package	-	-	4 (2)	4 (2)	6 (3)	6 (3)	8 (4)	-	-	-

Table 34: Vertical 3/8 in Coil Weights (Unit Sizes 060-100)

	Unit Size	Coil Type	Rows	Circuit Pattern	Coil Weight lbs (kg)			
					12 FPI	14 FPI	16 FPI	
Cooling	060	CW	2	Half	47.4 (21.5)	-	50.3 (22.8)	
		CW	4	Half	65.7 (29.8)	-	71.5 (32.4)	
		CW	4	Three Quarter	65.4 (29.7)	-	71.3 (32.3)	
		CW	6	Half	83.3 (37.8)	-	92.1 (41.8)	
		CW	6	Three Quarter	83.6 (37.9)	-	92.4 (41.9)	
		CW	8	Three Quarter	101.5 (46.1)	-	113.2 (51.4)	
	080	CW	2	Half	58.1 (26.4)	-	62.1 (28.2)	
		CW	4	Half	83.8 (38.0)	-	91.7 (41.6)	
		CW	4	Three Quarter	83.9 (38.1)	-	91.8 (41.6)	
		CW	6	Three Quarter	108.4 (49.2)	-	120.2 (54.6)	
		CW	6	Single	108.5 (49.2)	-	120.4 (54.6)	
		CW	8	Three Quarter	131.5 (59.6)	-	147.3 (66.8)	
	100	CW	2	Half	69.3 (31.4)	-	74.2 (33.7)	
		CW	4	Half	101.0 (45.8)	-	110.9 (50.3)	
		CW	4	Three Quarter	101.4 (46.0)	-	111.3 (50.5)	
		CW	6	Three Quarter	130.7 (59.3)	-	145.6 (66.1)	
		CW	6	Single	146.1 (66.3)	-	161.0 (73.1)	
		CW	8	Single	162.2 (73.6)	-	182.1 (82.6)	
	Heating	060	HW	1	Half	31.7 (14.4)	-	33.1 (15.0)
			HW	2	Half	41.1 (18.6)	-	44.0 (20.0)
			HW	2	Single	41.0 (18.6)	-	43.9 (19.9)
080		HW	1	Half	38.9 (17.7)	-	40.9 (18.6)	
		HW	2	Half	51.7 (23.4)	-	55.6 (25.2)	
		HW	2	Single	51.6 (23.4)	-	55.6 (25.2)	
100		HW	1	Half	46.8 (21.2)	-	49.3 (22.4)	
		HW	2	Half	62.5 (28.4)	-	67.5 (30.6)	
		HW	2	Single	63.1 (28.6)	-	68.1 (30.9)	
Defrost	060	HW	1	Half	31.7 (14.4)	-	33.1 (15.0)	
		HW	2	Half	41.1 (18.6)	-	44.0 (20.0)	
		HW	2	Single	41.0 (18.6)	-	43.9 (19.9)	
	080	HW	1	Half	38.9 (17.7)	-	40.9 (18.6)	
		HW	2	Half	51.7 (23.4)	-	55.6 (25.2)	
		HW	2	Single	51.6 (23.4)	-	55.6 (25.2)	
	100	HW	1	Half	46.8 (21.2)	-	49.3 (22.4)	
		HW	2	Half	62.5 (28.4)	-	67.5 (30.6)	
		HW	2	Single	63.1 (28.6)	-	68.1 (30.9)	
DX Normal	060	DX	3	Single DX	54.4 (24.7)	56.5 (25.7)	58.7 (26.7)	
	080	DX	3	Single DX	68.5 (31.1)	71.4 (32.4)	74.4 (33.8)	
	100	DX	3	Single DX	91.7 (41.6)	110.0 (50.0)	113.8 (51.6)	
DX Normal GALV	060	DX	3	Single DX	53.9 (24.5)	56.0 (25.4)	58.2 (26.4)	
	080	DX	3	Single DX	63.1 (28.6)	65.3 (29.6)	67.5 (30.6)	
	100	DX	3	Single DX	68.8 (31.2)	111.6 (50.7)	115.3 (52.3)	
DX Interlace	060	DX	3	Interlaced DX	56.0 (25.4)	58.2 (26.4)	60.4 (27.4)	
		DX	6	Interlaced DX	84.5 (38.4)	88.9 (40.3)	93.2 (42.3)	
	080	DX	3	Interlaced DX	69.5 (31.5)	72.4 (32.9)	75.4 (34.2)	
		DX	6	Interlaced DX	108.0 (49.0)	114.0 (51.7)	119.9 (54.4)	
	100	DX	3	Interlaced DX	104.0 (47.2)	107.8 (48.9)	111.5 (50.6)	
		DX	6	Interlaced DX	130.9 (59.4)	138.4 (62.8)	145.8 (66.2)	
DX Interlace GALV	060	DX	3	Interlaced DX	55.5 (25.2)	57.7 (26.2)	59.9 (27.2)	
		DX	6	Interlaced DX	84.0 (38.1)	88.3 (40.1)	92.7 (42.1)	
	080	DX	3	Interlaced DX	68.9 (31.3)	71.9 (32.6)	74.8 (34.0)	
		DX	6	Interlaced DX	107.4 (48.8)	113.4 (51.5)	119.3 (54.2)	
	100	DX	3	Interlaced DX	103.4 (47.0)	107.1 (48.6)	110.9 (50.3)	
		DX	6	Interlaced DX	130.3 (59.1)	137.7 (62.5)	145.2 (65.9)	

Table 35: Vertical Component Weights (Unit Sizes 060-100)

Component	Weight — lbs (kg)		
	060	080	100
Fan Supply Section	233 (106)	217 (98)	213 (97)
Single Supply Fan Weight	172 (78)	172 (78)	172 (78)
Dual Supply Fan Weight	272 (123)	272 (123)	272 (123)
Coil Section	221 (100)	271 (123)	279 (126)
Prefilter	98 (44)	101 (46)	123 (56)
Mixing box	653 (296)	637 (289)	635 (288)
Economizer End	691 (313)	669 (303)	658 (298)
Economizer	708 (321)	669 (304)	665 (302)
Post-Electric Heater	560 (254)	560 (254)	560 (254)
Exhaust Air/Outdoor Air	359 (163)	360 (163)	356 (162)
Single EA Fans	191 (87)	191 (87)	191 (87)
Dual EA Fans	315 (143)	315 (143)	315 (143)

Table 36: Vertical 5/8 in Turbo Spiral Coil Weights (Unit Sizes 060-100)

	Unit Size	Coil Type	Rows	Circuit Pattern	FPI	Weight lbs (kg)
Turbo Spiral	060	CW	2	Q	12	56 (26)
		CW	4	H	12	92 (42)
		CW	6	L	12	126 (57)
	080	CW	2	Q	12	73 (33)
		CW	4	H	12	120 (54)
		CW	6	L	12	165 (75)
	100	CW	2	Q	12	92 (42)
		CW	4	H	12	152 (69)
		CW	6	L	12	211 (96)

Table 37: Energy Recovery Weights (Vertical Unit Sizes 060-100)

Component	Weight lbs (kg)
Electric Heat Defrost	180 (82)
ERW Section, 46 in	498 (226)
ERW, 46 in	185 (84)
ERW Section, 52 in	610 (276)
ERW, 52 in	220 (100)
ERW Section, 58 in	932 (423)
ERW, 58 in	320 (145)

NOTE: The ERW section weight does not include the weight of the ERW. The weight of the wheel must be add to the weight of the section for total weight.

Fan and Motor Data

Table 38: Horizontal Fan and Motor Data - Unit Sizes 006-050 (Forward-Curved Fans)

Forward-Curved Fan Data										
Unit Size	006	008	010	012	016	018	020	030	040	050
Fan Quantity	1	1	1	1	2	2	2	1	1	1
Fan Type	FC, DWDI	FC, DWDI	FC, DWDI	FC, DWDI	FC, DWDI	FC, DWDI	FC, DWDI	FC, DWDI	FC, DWDI	FC, DWDI
Fan Size	9.5" X 4.5"	9.5" X 4.5"	9.5" X 4.5"	9.5" X 4.5"	9.5" X 4.5"	9.5" X 4.5"	9.5" X 4.5"	10" X 10"	12" X 12"	12" X 12"
Maximum RPM	2065	2065	2065	2065	2065	2065	2065	2100	1800	1800
Class	1	1	1	1	1	1	1	2	2	2
EC Motors	1	1	1	1	2*	2*	2*	-	-	-
Poly Phase Motors	-	-	-	-	-	-	-	1	1	1
1/3 HP	X	X			X					
1/2 HP	X	X	X	X	X	X	X			
3/4 HP	X	X	X	X	X	X	X			
1 HP			X	X		X	X			
1½ HP								X		
2 HP								X	X	
3 HP								X**	X	
5 HP									X**	X
7½ HP										X**

* Motors are the same HP

** HP is limited by VFD size

Table 39: Horizontal Fan and Motor Data - Unit Sizes 060-100 (Forward-Curved Exhaust Fans)

Forward-Curved Fan Data			
Unit Size	060	080	100
Fan Quantity	1 or 2	2 or 3	2 or 3
Fan Type	DWDI	DWDI	DWDI
Fan Size	9.5" X 4.5"	9.5" X 4.5"	9.5" X 4.5"
Maximum RPM	2065	2065	2065
Class	1	1	1
EC Motors	1 or 2	2 or 3	2 or 3
Poly Phase EC Motors	1 or 2	2 or 3	2 or 3
Motor 1/2 HP	X	X	X
Motor 1 HP	X	X	X

Table 40: Horizontal Fan and Motor Data - Unit Sizes 030-050 (Plenum Supply Fans)

Plenum Fan Data			
Unit Size	030	040	050
Fan Quantity	1	2	2
Fan Size	355 mm	355 mm	355 mm
Maximum RPM	3300	3300	3300
EC Motors	1	2	2
Poly Phase EC Motors	1	2	2
Motor 4.42 HP	X	X	X

Table 41: Horizontal Fan and Motor Data - Unit Sizes 060-100 (Plenum Supply Fans)

Plenum Fan Data			
Unit Size	060	080	100
Fan Quantity	1 or 2	1 or 2	1 or 2
Fan Size	450 mm	450 mm	450 mm
Maximum RPM	2600	2600	2600
EC Motors	1 or 2	1 or 2	1 or 2
Poly Phase EC Motors	1 or 2	1 or 2	1 or 2
Motor 3.7 HP	X	X	X
Motor 6.63 HP	X	X	X

Table 42: Vertical Fan and Motor Data - Unit Sizes 006-050 (Forward-Curved Fans)

Forward-Curved Fan Data								
Unit Size	006	008	012	016	020	030	040	050
Fan Quantity	1	1	1	2	2	1	1	1
Fan Type	FC, DWDI	FC, DWDI	FC, DWDI	FC, DWDI	FC, DWDI	FC, DWDI	FC, DWDI	FC, DWDI
Fan Size	9.5" X 4.5"	9.5" X 4.5"	9.5" X 4.5"	9.5" X 4.5"	9.5" X 4.5"	10.5" x 10.5"	12.5" x 12.5"	12.5" x 12.5"
Maximum RPM	2065	2065	2065	2065	2065	2100	1800	1800
Class	1	1	1	1	1	2	2	2
EC Motors	1	1	1	2 ¹	2 ¹	-	-	-
Poly Phase Motors	-	-	-	-	-	1	1	1
Motor 1/3 HP	X	X		X				
Motor 1/2 HP	X	X	X	X	X			
Motor 3/4 HP	X	X	X	X	X			
Motor 1 HP			X		X			
Motor 1½ HP ²						X		
Motor 2 HP ²						X	X	
Motor 3 HP ²						X	X	
Motor 5 HP							X	X
Motor 7½ HP								X

¹ Motors are the same HP
² HP is limited by VFD size

Table 43: Vertical Fan and Motor Data - Unit Sizes 030-100 (Plenum Supply Fans)

Plenum Fan Data						
Unit Size	030	040	050	060	080	100
Fan Quantity	1	2	2	1	1	1
				2	2	2
Fan Size	355 mm	355 mm	355 mm	355 mm	355 mm	355 mm
				450 mm	450 mm	450 mm
Maximum RPM	3300	3300	3300	3300	3300	3300
				2600	2600	2600
EC Motors	1	2	2	-	-	-
Poly Phase EC Motors	1	2	2	3	3	3
Motor 2.25 HP				-	-	-
Motor 3.7 HP				X	X	X
Motor 4.42 HP	X	X	X	X	X	X
Motor 6.63 HP				X	X	X

Filter Data

Table 44: Horizontal Filter Data for Main Unit and Optional Mixing Box Sections

Main Unit Filters															
Unit Size	006	008	010	012	016	018	020	030	040	050	060	080	100		
Quantity	1	1	2	2	2	2	2	2	2	2	4	6	3	6	
Height (inches)	17.69							25.38	29.75	28.00	24.00	18.00	20.00	20.00	
Width (inches)	11.60	16.62	13.75		17.94	22.25		21.88	24.50	31.75	24.00	24.00	16.00	20.00	
Nom. Face Velocity (FPM)	421	393	296	355	363	329	366	389	395	408	375	444	429		
(Optional) Mixing Box Filters															
Quantity	1	1	2	2	2	2	2	2	2	2	4	6	3		
Height (inches)	18.50							23.50	27.50	29.50	24.00	24.00	16.00		
Width (inches)	12.50	17.50	12.75		17.00	21.25		23.25	25.75	29.25	24.00	18.00	20.00		

Table 45: Vertical Filter Data for Main Unit and Optional Mixing Box/Economizer, Energy Recovery Wheel, and Exhaust Sections

External Filters														
Unit Size	006	008	012	016	020	030	040	050	060	080	100			
Quantity	1	1	1	2	2	2	2	4	2	4	6	8	4	8
Height	12	12	18	16	16	25	12	20	20	18	12	18	18	18
Width	24	24	24	20	20	20	24	24	24	24	24	24	24	24
Nom. Face Velocity (FPM)	300	400	300	360	450	432	375	375	375	444	444	429		
Internal Filter Rack														
Quantity	1	1	1	2	2	-	-	-	-	-	-	-	-	-
Height	12	18	20	16	16	-	-	-	-	-	-	-	-	-
Width	20	24	24	20	20	-	-	-	-	-	-	-	-	-
(Optional) Mixing Box/Economizer Filters														
Quantity	-	-	-	-	-	2	4	4	2	4	6	8	4	8
Height	-	-	-	-	-	24	16	20	18	12	18	18	18	18
Width	-	-	-	-	-	20	20	20	24	24	24	24	24	24
(Optional) Energy Recovery Wheel Filter														
Quantity	-	-	-	-	-	-	-	-	4	4	4	4	4	4
Height	-	-	-	-	-	-	-	-	18	18	18	18	18	18
Width	-	-	-	-	-	-	-	-	24	24	24	24	24	24
(Optional) Exhaust Section Filter														
Quantity	-	-	-	-	-	-	-	-	1	2	4	4	4	4
Height	-	-	-	-	-	-	-	-	12	16	17.13	18	18	18
Width	-	-	-	-	-	-	-	-	20	20	17.69	24	24	24

Table 46: Filter Pressure Drop

Face Velocity (Feet per minute)	Clean Pressure Drop				
	100	200	300	400	500
2" Filter					
Merv 4	0.02	0.04	0.08	0.11	0.16
Merv 8	0.02	0.07	0.12	0.19	0.27
Merv 13	0.08	0.17	0.27	0.37	0.48
4" Filter					
Merv 8	0.01	0.03	0.06	0.1	0.14
Merv 13	0.02	0.07	0.12	0.19	0.27

Thermal Expansion Valve (TXV)

For each unit size there are two TXV options available. TXV Option 1 is optimized for the standard entering air and suction temperatures while Option 2 is intended for applications with higher entering air temperatures and lower suction temperatures.

Table 47: Horizontal TXV Connection Sizes

Unit Size	Circuits		FPI	TXV Connection Size			
	Number	Type		R-32		R-454B	
				Inlet	Outlet	Inlet	Outlet
006	1	Normal	12	3/8	1/2	3/8	1/2
			16	3/8	1/2	3/8	1/2
008	1	Normal	12	3/8	1/2	1/2	1/2
			16	3/8	1/2	1/2	1/2
010	1	Normal	12	3/8	1/2	1/2	1/2
			16	3/8	1/2	1/2	1/2
012	1	Normal	12	3/8	1/2	1/2	1/2
			16	3/8	1/2	1/2	1/2
016	1	Normal	12	3/8	5/8	1/2	1/2
			16	3/8	5/8	1/2	1/2
018	1	Normal	12	3/8	1/2	5/8	1/2
			16	3/8	1/2	5/8	1/2
020	1	Normal	12	3/8	1/2	5/8	1/2
			16	3/8	1/2	5/8	1/2
030	1	Normal	12	1/2	7/8	5/8	7/8
			16	1/2	7/8	5/8	7/8
	2	Interlaced	12	3/8	1/2	1/2	1/2
			16	3/8	1/2	1/2	1/2
040	1	Normal	12	1/2	7/8	5/8	7/8
			16	1/2	7/8	5/8	7/8
	2	Interlaced	12	1/2	5/8	1/2	5/8
			16	1/2	5/8	1/2	5/8
050	1	Normal	12	5/8	7/8	7/8	7/8
			16	5/8	7/8	7/8	7/8
	2	Interlaced	12	1/2	5/8	5/8	5/8
			16	1/2	5/8	5/8	5/8
060	2	Normal	12	1/2	7/8	5/8	7/8
			16	1/2	7/8	5/8	7/8
	4	Interlaced	12	3/8	1/2	1/2	1/2
			16	3/8	1/2	1/2	1/2
080	2	Normal	12	1/2	7/8	5/8	7/8
			16	1/2	7/8	5/8	7/8
	4	Interlaced	12	1/2	5/8	1/2	5/8
			16	1/2	5/8	1/2	5/8
100	2	Normal	12	5/8	7/8	7/8	7/8
			16	5/8	7/8	7/8	7/8
	4	Interlaced	12	1/2	5/8	5/8	5/8
			16	1/2	5/8	5/8	5/8

NOTE 1: TXV inlet size is the recommended liquid line size when using factory provided TXV.

NOTE 2: Sizes 060-100 have stacked coils.

Table 48: Vertical TXV Connection Sizes

Unit Size	Rows	Circuits		FPI	TXV Connection Size			
					R-32		R-454B	
		Number	Type		Inlet	Outlet	Inlet	Outlet
006	3	1	Normal	12	3/8	1/2	1/2	1/2
				14	3/8	1/2	1/2	1/2
				16	3/8	1/2	1/2	1/2
	6	1	Normal	12	3/8	1/2	1/2	1/2
				14	3/8	1/2	1/2	1/2
				16	3/8	1/2	1/2	1/2
008	3	1	Normal	12	3/8	1/2	1/2	1/2
				14	3/8	1/2	1/2	1/2
				16	3/8	1/2	1/2	1/2
	6	1	Normal	12	3/8	1/2	1/2	1/2
				14	3/8	1/2	1/2	1/2
				16	3/8	1/2	1/2	1/2
012	3	1	Normal	12	3/8	1/2	1/2	1/2
				14	3/8	1/2	1/2	1/2
				16	3/8	1/2	1/2	1/2
	6	1	Normal	12	3/8	5/8	1/2	5/8
				14	3/8	5/8	1/2	5/8
				16	3/8	5/8	1/2	5/8
016	3	1	Normal	12	3/8	5/8	1/2	5/8
				14	3/8	5/8	1/2	5/8
				16	3/8	5/8	1/2	5/8
	6	1	Normal	12	3/8	5/8	5/8	7/8
				14	3/8	5/8	5/8	7/8
				16	3/8	5/8	5/8	7/8
020	3	1	Normal	12	3/8	5/8	5/8	7/8
				14	3/8	5/8	5/8	7/8
				16	3/8	5/8	5/8	7/8
	6	1	Normal	12	3/8	7/8	5/8	7/8
				14	3/8	7/8	5/8	7/8
				16	3/8	7/8	5/8	7/8
030	3	1	Normal	12	1/2	7/8	1/2	7/8
				14	1/2	7/8	1/2	7/8
				16	1/2	7/8	1/2	7/8
	3	2	Interlaced	12	3/8	1/2	1/2	7/8
				14	3/8	1/2	1/2	7/8
				16	3/8	1/2	1/2	7/8
	6	2	Interlaced	12	3/8	7/8	5/8	7/8
				14	3/8	7/8	5/8	7/8
				16	3/8	7/8	5/8	7/8

Unit Size	Rows	Circuits		FPI	TXV Connection Size			
					R-32		R-454B	
		Number	Type		Inlet	Outlet	Inlet	Outlet
040	3	1	Normal	12	1/2	7/8	7/8	7/8
				14	1/2	7/8	7/8	7/8
				16	1/2	7/8	7/8	7/8
	3	2	Interlaced	12	1/2	5/8	5/8	7/8
				14	1/2	5/8	5/8	7/8
				16	1/2	5/8	5/8	7/8
	6	2	Interlaced	12	1/2	7/8	5/8	7/8
				14	1/2	7/8	5/8	7/8
				16	1/2	7/8	5/8	7/8
050	3	1	Normal	12	5/8	7/8	7/8	7/8
				14	5/8	7/8	7/8	7/8
				16	5/8	7/8	7/8	7/8
	3	2	Interlaced	12	1/2	7/8	5/8	7/8
				14	1/2	7/8	5/8	7/8
				16	1/2	7/8	5/8	7/8
	6	2	Interlaced	12	1/2	7/8	7/8	7/8
				14	1/2	7/8	7/8	7/8
				16	1/2	7/8	7/8	7/8
60	3	2	Normal	12	1/2	7/8	1/2	7/8
				14	1/2	7/8	1/2	7/8
				16	1/2	7/8	1/2	7/8
	3	4	Interlaced	12	3/8	7/8	1/2	7/8
				14	3/8	7/8	1/2	7/8
				16	3/8	7/8	1/2	7/8
	6	2	Interlaced	12	1/2	7/8	5/8	7/8
				14	1/2	7/8	5/8	7/8
				16	1/2	7/8	5/8	7/8
080	3	2	Normal	12	1/2	7/8	7/8	7/8
				14	1/2	7/8	7/8	7/8
				16	1/2	7/8	7/8	7/8
	3	4	Interlaced	12	1/2	5/8	5/8	5/8
				14	1/2	5/8	5/8	5/8
				16	1/2	5/8	5/8	5/8
	6	2	Interlaced	12	1/2	7/8	5/8	7/8
				14	1/2	7/8	5/8	7/8
				16	1/2	7/8	5/8	7/8
100	3	2	Normal	12	5/8	7/8	7/8	7/8
				14	5/8	7/8	7/8	7/8
				16	5/8	7/8	7/8	7/8
	3	4	Interlaced	12	1/2	7/8	5/8	7/8
				14	1/2	7/8	5/8	7/8
				16	1/2	7/8	5/8	7/8
	6	2	Interlaced	12	1/2	7/8	7/8	7/8
				14	1/2	7/8	7/8	7/8
				16	1/2	7/8	7/8	7/8

NOTE 1: TXV inlet size is the recommended liquid line size when using factory provided TXV.

NOTE 2: Sizes 060-100 have stacked coils.

Unit Selection

A mechanical heating, ventilation, and cooling system realizes thermal comfort and high efficiency through accurate space design and thoughtful equipment selection. Variations and limitations of centralized air handler systems and de-centralized fan coil systems are not outlined in this manual but must be fully understood. Design conditions and load calculations are not discussed in detail in this catalog but can be further explored and studied in the ASHRAE Guide. This catalog includes AHRI-certified ratings which a design engineer may make use of in initial system design and equipment specification.

A mechanical system designer must select the unit types best suited to the overall system before the actual unit sizes can be determined. The factors that generally influence this decision are: intended building usage, building layout, architectural and aesthetic values, economics, geographical location, and type of maintenance service available. The general results may be a mixture of unit types within a given system. Daikin Applied manufactures fan coil units to meet many needs including ThinLine, OptiLine, and Economy models. For Daikin Applied product information, please go to www.DaikinApplied.com.

Basic Design Data

Prior to selecting individual unit sizes, a design engineer must fix or determine the following factors:

- Inside and outside wet and dry bulb design temperatures
- Total and sensible heat gains and losses of the area to be served
- Ventilation air
- Properties of the heating and cooling medium
- Available electric power service
- Any special design requirements of the building or system

Unit Size

The capacity ratings presented in this catalog are provided for initial unit selection only. Water cooling and heating capacities, unit air flow, static pressure and glycol solutions are all incorporated into Daikin Select Tools (DST) to provide the best possible selection. Consult your Daikin Applied representative for a selection tailored to specific applications. Unit sizes for the ideal system should be selected by calculating peak load requirements due to unusually high occupancy or severe climatic conditions and with fans operating at high speed. Ordinary day-to-day cooling and heating requirements are then achieved at low and medium speeds. The initial unit selection should be checked for air volume in the design system and the cooling capacities checked against actual operating conditions. While units selected on the basis of sensible load will generally meet the total cooling load, total load should be checked in all cases. The unit size is generally selected on the basis of matching the sensible cooling capacity of the unit with the calculated requirements when operating at high speed.

Coil Types

Standard coils are designed to meet both cooling and heating requirements in a typical system. Multiple primary coil options are available to meet the total and sensible requirements of any application. Heating requirements for systems are generally met by specifying entering water temperature and leaving water temperature, allowing a water flow rate to be calculated.

Four-pipe and Two-pipe systems are available. Daikin Applied offers two coil options for preheat or reheat.

Four-Pipe Systems

Four-Pipe systems refer to a piece of air handling equipment that utilizes two distinct coils. One of the coils only operates in a cooling mode, and the other coil only operates in a heating mode. The advantage to this system setup is the ability to let the unit choose whether to employ cooling or heating mode at any one instant. During the shoulder seasons when space loads change based on sun exposure, occupant activity, plug loads, and other factors, some thermal spaces may require cooling while others require heating. Because the unit has two distinct coils piped to the chiller and boiler systems individually, the unit can choose which system to use.

Two-Pipe Systems

Two-Pipe systems refer to a piece of air handling equipment that utilizes a single coil. This coil can operate as a cooling only coil, a cooling and heating coil, or a heating coil. The "two-pipe" designation comes from how typically only two fluid pipes, one supply and one return, are run to each unit. The advantage to this system is first cost. Only one set of pipes (one return, one supply) to the unit is necessary. This effectively cuts the piping material cost in half.

Four and Two-Pipe Performance Measurements

All performance data is given assuming nominal cabinet airflow, which is achievable with up to 1.5" of external static pressure.

Cooling performance is based on 80/67°F (27/19°C) entering air temperature, 45°F (7°C) entering chilled water temperature with a 10°F (5.5°C) temperature rise.

Heating performance is based on 70°F (21°C) entering air temperature, 180°F (82°C) entering hot water temperature with a 30°F (17°C) temperature drop.

For other conditions and/or unit configurations, refer to DST or talk to your local Daikin Applied representative.

Electrical Data

Calculations to realize MCA (Maximum Circuit Ampacity) and MROPD (Maximum Rated Overcurrent Protection Device) are explained in this section. MROPD (Maximum Rated Overcurrent Protection Device), MOP (Maximum Overcurrent Protection), MFS (Maximum Fuse Size) are synonymous in this section.

The minimum circuit ampacity (MCA) is the minimum conductor size required for a field-wired product. The MROPD (Maximum Rated Overcurrent Protection Device), MOP (Maximum Overcurrent Protection), or MFS (Maximum Fuse Size) is the maximum fuse or circuit breaker size required to properly protect the equipment. The MROPD will always be greater than the MCA for any given supply circuit.

The circuit's required fusing or HACR (Heating, Air-Conditioning and Refrigeration) type circuit breaker size is determined from the circuit's MCA and calculated MROPD.

$$\text{Heater Amps} = \left(\frac{\text{Heater kW} \times 1000}{\text{Heater Voltage}} \right)$$

NOTICE

Use 120V heater voltage for 115V units. Use 240V heater voltage for 230V units.

$$\text{MCA} = 1.25 \times (\text{Heater Amps} + \text{all motor FLAs})$$

$$\text{Calculated MROPD} = 2.25 \times (\text{Largest Motor FLAs} + \text{Other Motor FLA's} + \text{Electric Heater Amps})$$

The circuit's MROPD is the next standard size fuse smaller than the calculated MROPD if that standard fuse sizes is greater than the MCA.

If the MCA is greater than the next standard size fuse smaller than the calculated MROPD, the circuit's MROPD is the next standard size fuse larger than the MCA.

If the circuit's MROPD is smaller than 15A, it shall be rounded up to 15A.

The temperature of the air leaving the unit (LAT) which is dependent on the entering air temperature (EAT), electric heat capacity (kW), and the air volume (CFM), must not exceed 125°F (52°C). The minimum allowable air volume for various combinations of EAT and kW are provided in [Table 16 on page 34](#) or may be calculated using the equation below.

$$\text{LAT} = (\text{kW} \times 3145.622 \div \text{CFM}) + \text{EAT}$$

Electric Heat Safety

Overcurrent Protection

Optional factory provided over current protection is available on all units with a maximum operating current less than or equal to 48 amps. This protection is provided with fuses located on the unit main power circuit. Units with a maximum operating current greater than 48 amps will come with factory-installed fusing on the electric heat circuit.

Thermal (Over Temperature) Protection

All units with electric heat are provided with at least two thermal protection devices. The primary thermal protection device is an automatic limit switch which opens when it reaches a temperature of 150°F (66°C). The switch will reset itself when the temperature drops below 110°F (43°C). The secondary thermal protection device is a manual reset thermal cutout. This switch opens when it reaches 180°F (82°C) for horizontal units and 210°F (99°C) for vertical units, but must be reset manually after the over temperature issue has been resolved. Units provided with the SCR type electric heat control have an additional automatic thermal protection built into the SCR controller. This switch opens the circuit when the temperature reaches 170°F (77°C).

Valve Package Selections

All factory-installed valve packages are configurable through DST for GPM, Cv, and control type. Factory-installed valve packages ship with foam inserts for added support. Factory-installed valve packages include unions for easy removal of cooling and heating coils.

The optional factory-installed deluxe valve package includes a temperature control valve, a ball shut off valve with supply strainer, P/T port and clean out, and an automatic flow control valve with ball shut off and P/T ports. The temperature control valve is a flow ball valve with SS ball and stem and is selectable as 2-way or 3-way. The valve flow coefficient and connection ports are appropriately sized for the selected flow rate. The control actuator can be configured for spring return on-off normally closed to the coil, spring return on-off normally open to the coil, or non-spring return 0-10VDC modulating control. A strainer and ball shut off valve assembly and an automatic flow control valve and shut off assembly are also available. The piping schematic examples are shown in [Figure 31](#) through [Figure 37](#).

On vertical units sizes 006 and 008, the control valve can be selected as either 2-way or 3-way, N.O. or N.C., and have a manually adjustable Cv ranging from 0.5 to 5.9. See [Figure 32](#).

NOTICE

These valves are located on the supply side, adjacent to the coil, in contrast with other configurations being located on the return side.

Figure 31: Basic 2-Way Valve Package

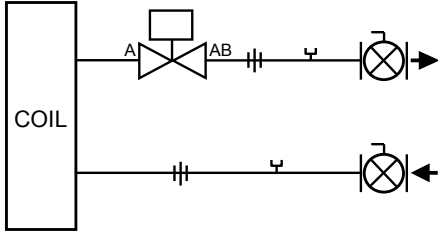

Figure 32: Basic 2-Way Valve Package Available for Vertical Unit Sizes 006-008 with Manually Adjustable Cv

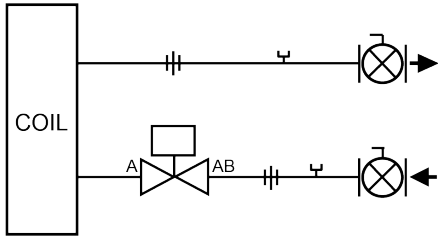

Figure 33: Basic 3-Way Valve Package

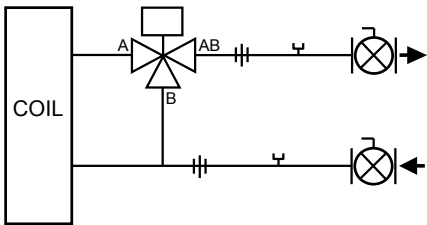

Figure 34: Deluxe 2-Way Valve Package (Auto CS)

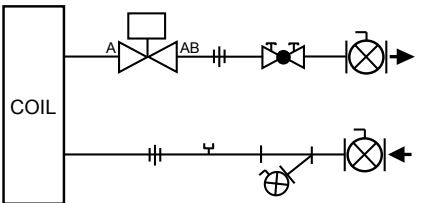

Figure 35: Deluxe 3-Way Valve Package (Auto CS)

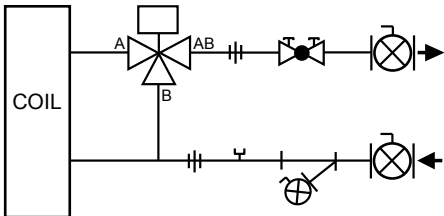

Figure 36: Deluxe 2-Way Valve Package (Manual CS)

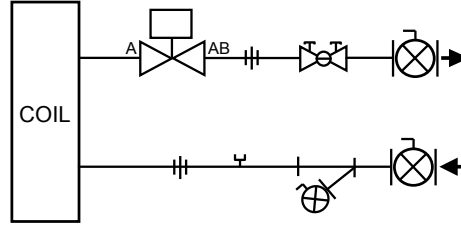

Figure 37: Deluxe 3-Way Valve Package (Manual CS)

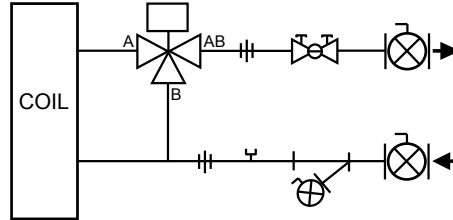

Table 49: Components Key for Schematics

	Manual Shutoff Ball Valve with Memory Stop: Used on return line for limiting water flow.
	2-Way, ON/OFF Valve: Turn ON or OFF water flow to the coil in response to 24V or line voltage signal.
	3-Way, ON/OFF Valve: Bypass water flow away from coil in response to 24V or line voltage signal. Includes fixed orifice for balancing.
	PT Port: For connecting a pressure or temperature gauge.
	Y-Strainer: Removable screen filters out small particles from supply line during normal system operation.
	Auto Circuit Setter: Pressure-compensated, automatic flow control.
	Manual Circuit Setter: Pressure-compensated, manual flow control.
	Union: For easy removal of piping from coil.

NOTE: Daikin Applied 3-way valves are equipped with a fixed balance orifice in the bypass line, eliminating the need for a separate balancing valve.

Dimensional Drawings

Size 006-050 Horizontal Unit Dimensions

Figure 38: Left-Hand, Single and Dual Fan (Unit Sizes 006-020)

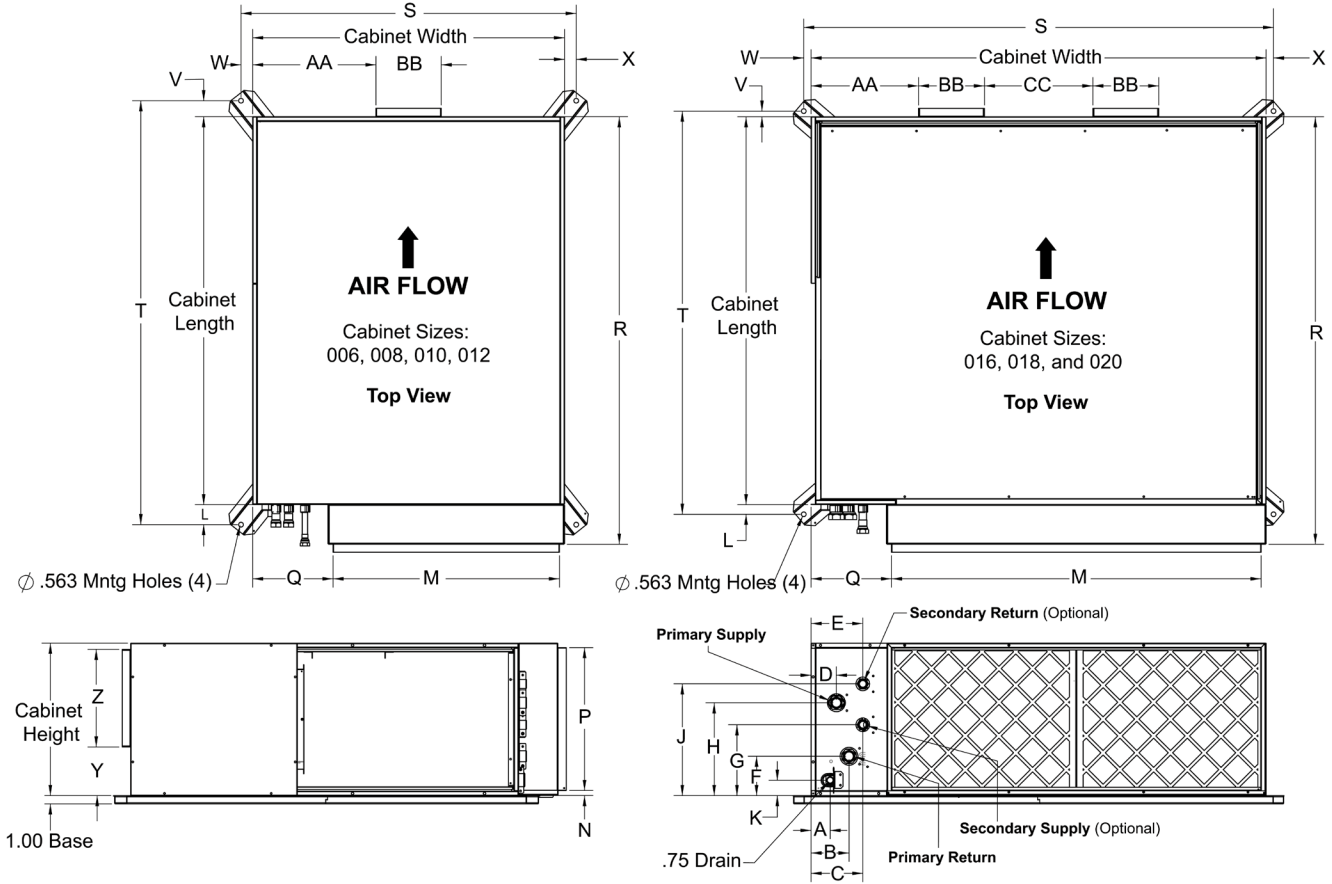

- Overall Cabinet Dimensions**
 006 = 43L x 24W x 18H
 008 = 43L x 29W x 18H
 010 & 012 = 46L x 37W x 18H
 016 = 46L x 45.5W x 18H
 018 & 020 = 46L x 54W x 18H

NOTE 1: Dimensions shown in inches.

NOTE 2: Left hand unit shown. Right hand unit same as left but opposite.

Table 50: Dimension Letter Reference for Figure 38 on page 67

Dimension	006	008	010	012	016	018	020
A	2.26	2.28	2.18	2.18	2.60	2.25	2.25
B	4.01	4.51	4.26	4.26	4.52	4.50	4.50
C	5.75	6.45	6.24	6.24	6.15	6.19	6.19
D	2.51	3.00	2.76	2.76	3.02	3.00	3.00
E	5.75	6.42	6.24	6.24	6.15	6.15	6.15
F	5.45	5.42	4.67	4.67	4.67	4.67	4.67
G	7.42	7.40	8.13	8.13	8.38	8.38	8.38
H	11.03	10.77	11.15	11.15	11.03	11.03	11.03
J	13.85	13.32	13.26	13.26	13.27	13.27	13.27
K	1.83	1.80	1.83	1.83	1.83	1.83	1.83
L	1.70	1.38	2.42	2.42	1.79	1.18	1.18
M	11.61	16.61	26.87	26.87	35.27	43.87	43.87
N	0.67	0.59	0.60	0.60	0.60	0.60	0.60
P	16.97	16.97	16.97	16.97	16.97	16.97	16.97
Q	9.56	9.53	9.53	9.53	9.63	10.67	10.67
R Bottom Access	47.70	47.70	50.70	50.70	50.70	50.70	50.70
R Side Access	49.50	49.50	53.90	53.90	52.50	52.50	52.50
S	24.79	29.77	39.80	39.80	47.89	55.80	55.80
T	45.90	45.25	50.34	50.34	48.97	47.87	47.87
V	1.19	0.87	1.90	1.90	1.23	0.67	0.67
W	0.38	0.38	1.39	1.39	1.19	0.87	0.87
X	0.38	0.38	1.39	1.39	1.19	0.87	0.87
Y	5.77	5.77	5.77	5.77	5.77	5.77	5.77
Z	11.59	11.59	11.59	11.59	11.59	11.59	11.59
AA	8.13	10.63	14.63	14.63	9.24	12.74	12.74
BB	7.73	7.75	7.75	7.75	7.75	7.82	7.82
CC	0.00	0.00	0.00	0.00	11.53	12.88	12.88

NOTE: Dimensions shown in inches.

Figure 39: Left-Hand, Single Fan (Unit Sizes 030-050)

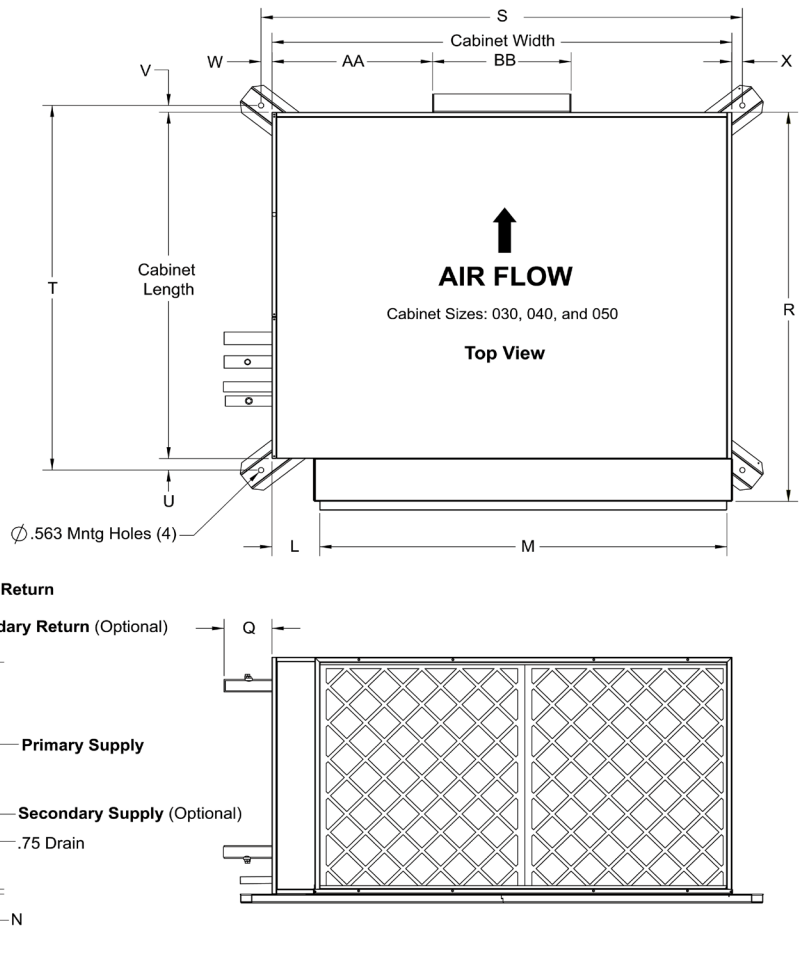

- NOTE 1:** Dimensions shown in inches.
- NOTE 2:** Refer to submittal drawings in Daikin Select Tools for piping connection dimensions.
- NOTE 3:** Left hand unit shown. Right hand unit same as left but opposite.
- NOTE 4:** Preheat option shown. Reheat option available.

Table 51: Dimension Letter Reference for Hanger Brackets

Dimension	030	040	050
R Bottom Access	42.65	45.72	45.66
R Side Access	44.40	47.40	47.40
L	1.26	1.16	0.87
S	51.23	56.02	62.59
T	40.01	42.80	42.22
V	0.74	0.63	0.35
W	1.15	1.01	0.80
X	1.12	1.01	0.80

NOTE: Dimensions shown in inches.

Table 52: Hydronic Unit Dimensions - Dimension Letter Reference for Figure 39 on page 69

Unit Size	Dimension	2-Row Cooling / Primary				4-Row Cooling / Primary				6-Row Cooling / Primary				8-Row Cooling / Primary
		Preheat		Reheat		Preheat		Reheat		Preheat		Reheat		
		1-Row	2-Row	1-Row	2-Row	1-Row	2-Row	1-Row	2-Row	1-Row	2-Row	1-Row	2-Row	
030	A	32	32	32	32	32	32	32	32	32	32	32	32	32.12
	B	24	24	24	24	24	24	24	24	24.81	24.81	24	24	24.81
	C	30.13	30.13	28.12	28.12	30.13	30.13	28.12	28.12	30.13	30.13	29	29	-
	D	25.5	26.56	25.12	25.12	26.56	26.56	25.12	25.12	27.41	27.41	25.12	25.12	29.16
	E	31.5	31.5	29.62	29.62	31.5	31.5	30.69	30.69	31.5	31.5	31.5	31.5	-
	G	4.62	4.62	4.62	4.62	4.62	4.62	4.62	4.62	4.62	4.62	4.62	4.62	-
040	J	22.86	22.86	22.86	22.86	22.86	22.86	22.86	22.86	22.86	22.86	22.86	22.86	-
	A	35.12	35.12	35.12	35.12	35.12	35.12	35.12	35.12	35.12	35.12	35.12	35.12	35.12
	B	27	27	27	27	27.87	27.87	27	27	27.87	37.87	27	27	27.83
	C	33.12	33.12	31.12	33.12	33.12	33.12	32	31.12	33.12	33.12	32	32	-
	D	28.5	28.5	28.5	28.5	30.5	30.5	28.5	28.5	30.5	30.5	28.25	28.25	32.16
	E	34.5	34.5	32.67	34.5	34.5	34.5	34.62	32.62	34.5	34.5	34.62	34.62	-
050	G	4.62	4.62	4.62	4.62	4.62	4.62	4.62	4.62	4.62	4.62	4.62	4.62	-
	J	26.87	26.87	26.87	26.87	26.87	26.87	26.87	26.87	26.87	26.87	26.87	26.87	-
	A	35.12	35.12	35.12	35.12	35.12	35.12	35.12	35.12	35.12	35.12	35.12	35.12	35.12
	B	27	27	27.68	27.68	27	27	27.68	27.68	27.87	27.87	27.75	27.75	27.79
	C	33.87	33.87	31.12	31.12	33.87	33.87	31.25	31.25	33.82	33.82	33.87	33.87	-
	D	29	29	29.12	29.12	29.68	29.68	29.12	29.12	30.37	30.37	30.43	30.43	32.12
050	E	35.44	35.44	33	33	35.31	35.31	33.82	33.82	35.25	35.25	35.31	35.31	-
	G	4.62	4.62	4.62	4.62	4.62	4.62	4.62	4.62	4.62	4.62	4.62	4.62	-
	J	28.87	28.87	28.87	28.87	28.87	28.87	28.87	28.87	28.87	28.87	28.87	28.87	-

NOTE: Dimensions shown in inches.

Table 53: Hydronic Unit Dimensions - Dimension Letter Reference for Figure 39 on page 69

Dimension	Unit Size		
	030	040	050
F	4.62	4.62	4.62
H	22.86	26.87	28.87
K	1.61	1.61	1.61
M	43.34	48.45	54.96
N	0.57	0.55	0.55
P	24.9	28.92	30.94
Q	5.08	5.01	5.5
Y (FC Fans)	9.73	9.51	10.25
Y (Plenum Fans)	4.94	7.97	6.95
Z (FC Fans)	11.47	13.53	13.53
Z (Plenum Fans)	27.13	14.06	18.13
AA (FC Fans)	23.35	22.64	22.64
AA (Plenum Fans)	10.93	6.47	10.43
BB (FC Fans)	13.21	15.62	15.62
BB (Plenum Fans)	16.13	41.06	40.13

NOTE: Dimensions shown in inches.

Table 54: DX Unit Dimensions - Dimension Letter Reference for Figure 39 on page 69

Unit Size	Dimension	Single Circuit DX				Interlaced DX			
		Preheat		Reheat		Preheat		Reheat	
		1-Row	2-Row	1-Row	2-Row	1-Row	2-Row	1-Row	2-Row
030	B	25.69	25.61	23.95	23.88	24.3	24.3	23.88	23.88
	C	30.16	30.07	29.83	29.76	30.07	30.07	28.45	28.45
	D	-	-	25.04	25.42	25.62	25.61	25.09	25.43
	E	31.24	31.61	-	-	31.28	31.61	29.76	29.76
	F	4.35	4.35	4.61	4.62	5.35	5.35	4.61	4.62
	G	4.62	4.65	4.35	4.35	4.62	4.62	5.35	5.35
	H	-	-	22.86	22.87	9.35	9.35	22.86	22.87
	J	22.87	22.87	-	-	22.87	22.87	9.35	9.35
040	B	28.69	28.7	26.97	26.97	27.26	27.26	26.97	26.97
	C	33.16	33.16	32.85	32.85	33.16	33.16	31.41	31.41
	D	-	-	28.29	28.52	28.7	28.7	28.29	28.52
	E	34.48	34.7	-	-	34.48	34.7	32.85	32.85
	F	4.35	4.35	5.65	4.62	5.35	5.35	5.62	4.62
	G	5.62	4.62	4.39	4.35	5.62	4.62	5.35	5.35
	H	-	-	25.38	26.87	9.35	9.35	25.37	26.87
	J	25.37	26.87	-	-	25.37	26.87	9.35	9.35
050	B	28.69	28.68	27.68	26.9	27.13	27.12	27.68	26.9
	C	33.87	33.09	32.84	32.83	33.87	33.09	31.27	31.26
	D	-	-	29.13	29.24	30.25	30.24	29.13	29.24
	E	35.32	35.43	-	-	35.32	35.43	34.4	34.39
	F	4.35	4.35	4.62	4.62	5.35	5.35	4.62	4.62
	G	4.62	4.62	4.35	4.35	4.62	4.62	5.35	5.35
	H	-	-	28.87	28.87	7.35	7.35	28.87	28.87
	J	28.87	28.87	-	-	28.87	28.87	7.35	7.35

NOTE: Dimensions shown in inches.

Table 55: DX Unit Dimensions - Dimension Letter Reference for Figure 39 on page 69

Dimension	Unit Size		
	030	040	050
A	32.1	35.1	35.1
K	1.61	1.61	1.61
M	43.34	48.45	54.96
N	0.57	0.55	0.55
P	24.9	28.92	30.94
Q	5.08	5.01	5.50
Y (FC Fans)	9.73	9.51	10.25
Y (Plenum Fans)	4.94	7.97	6.95
Z (FC Fans)	11.47	13.53	13.53
Z (Plenum Fans)	27.13	14.06	18.13
AA (FC Fans)	23.35	22.64	22.64
AA (Plenum Fans)	10.93	6.47	10.43
BB (FC Fans)	13.21	15.62	15.62
BB (Plenum Fans)	16.13	41.06	40.13

NOTE: Dimensions shown in inches.

Figure 40: Horizontal Mixing Box – Top and End Damper, Left Hand Unit Sizes 006–020 and Right Hand Unit Sizes 030–050 – Side Filter Access

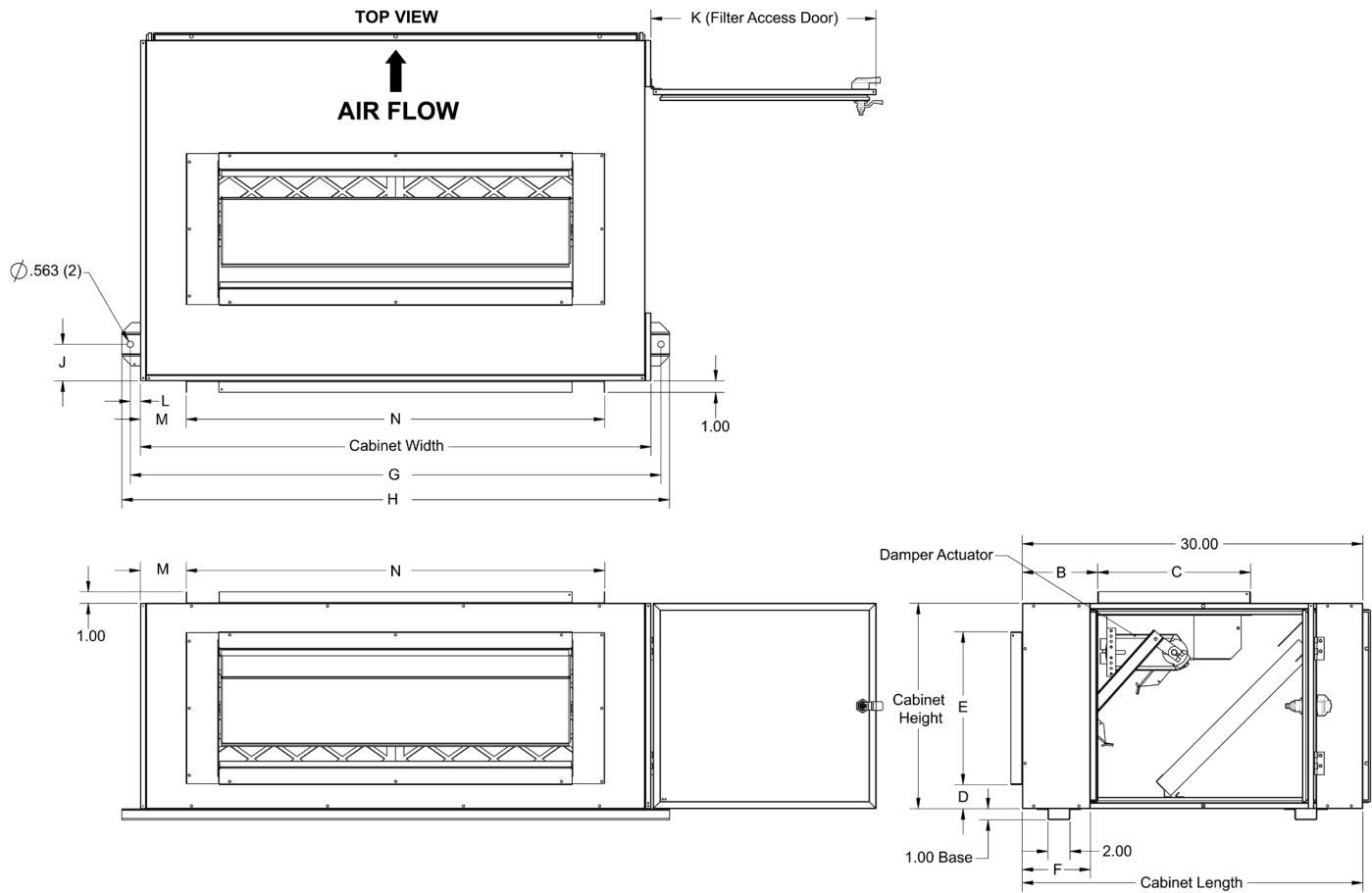

NOTE 1: Dimensions shown in inches.

NOTE 2: Dimensions for right hand cabinet unit sizes 006-020 and cabinet unit sizes 030-050 with side access filters are similar but opposite.

Table 56: Mixing Box Dimension Letter Reference

Cabinet	006	008	010	012	016	018	020	030	040	050
B	6.64	6.64	6.64	6.64	6.64	6.64	6.64	5.54	5.54	5.54
C	13.47	13.47	13.47	13.47	13.47	13.47	13.47	18.39	18.39	18.39
D	2.11	2.11	2.11	2.11	2.11	2.11	2.11	3.80	5.80	6.80
E	13.47	13.47	13.47	13.47	13.47	13.47	13.47	18.39	18.39	18.39
F	6.12	6.12	6.12	6.12	6.12	6.12	6.12	14.06	14.06	14.06
G	16.75	21.75	29.75	29.75	38.25	46.75	46.75	51.00	56.00	63.00
H	18.25	23.25	31.25	31.25	39.75	48.25	48.25	52.50	57.50	64.50
J	3.22	3.22	3.22	3.22	3.22	3.22	3.22	3.22	3.22	3.22
K	19.75	19.75	19.75	19.75	19.75	19.75	19.75	14.75	14.75	14.75
L	0.87	0.87	0.87	0.87	0.87	0.87	0.87	1.00	1.00	1.00
M	0.98	2.66	2.29	2.29	2.80	4.04	4.04	6.32	3.82	2.82
N	10.18	14.66	23.41	30.90	30.90	36.87	36.87	36.34	46.34	55.34

NOTE: Dimensions shown in inches.

Figure 41: Horizontal Mixing Box – Bottom and End Damper, Left Hand Unit Sizes 006–020 and Right Hand Unit Sizes 030–050 – Side Filter Access

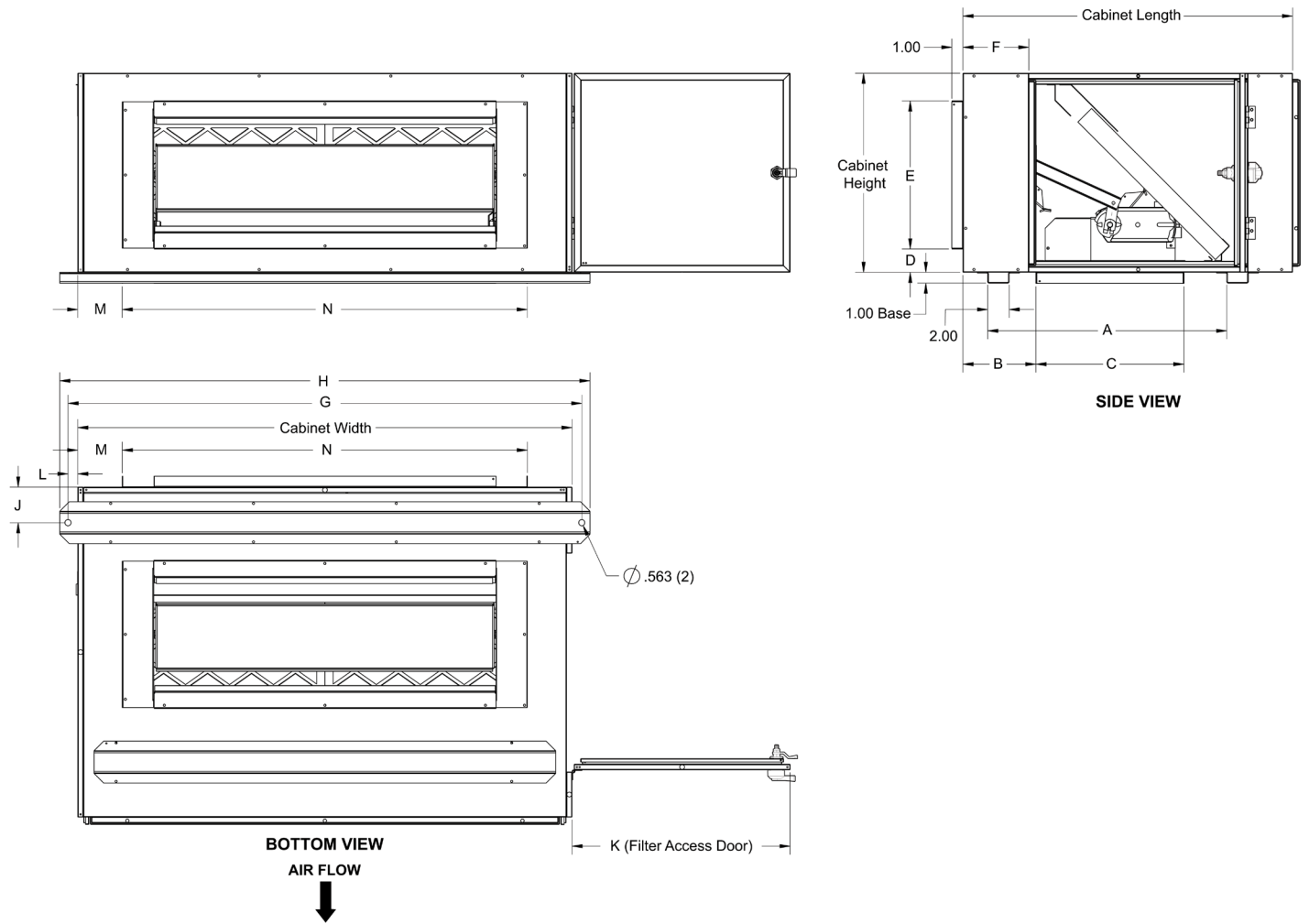

NOTE 1: Dimensions shown in inches.

NOTE 2: Dimensions for right hand cabinet unit sizes 006-020 and cabinet unit sizes 030-050 with side access filters are similar but opposite.

Table 57: Mixing Box Dimension Letter Reference

Cabinet	006	008	010	012	016	018	020	030	040	050
A	20.51	20.51	20.51	20.51	20.51	20.51	20.51	27.27	27.27	27.27
B	6.64	6.64	6.64	6.64	6.64	6.64	6.64	5.54	5.54	5.54
C	13.47	13.47	13.47	13.47	13.47	13.47	13.47	18.39	18.39	18.39
D	2.11	2.11	2.11	2.11	2.11	2.11	2.11	3.80	5.80	6.80
E	13.47	13.47	13.47	13.47	13.47	13.47	13.47	18.39	18.39	18.39
F	6.12	6.12	6.12	6.12	6.12	6.12	6.12	14.06	14.06	14.06
G	16.75	21.75	29.75	29.75	38.25	46.75	46.75	51.00	56.00	63.00
H	18.25	23.25	31.25	31.25	39.75	48.25	48.25	52.50	57.50	64.50
J	3.22	3.22	3.22	3.22	3.22	3.22	3.22	3.22	3.22	3.22
K	19.75	19.75	19.75	19.75	19.75	19.75	19.75	14.75	14.75	14.75
L	0.87	0.87	0.87	0.87	0.87	0.87	0.87	1.00	1.00	1.00
M	0.98	2.66	2.29	2.29	2.80	4.04	4.04	6.32	3.82	2.82
N	10.18	14.66	23.41	30.90	30.90	36.87	36.87	36.34	46.34	55.34

NOTE: Dimensions shown in inches.

Figure 42: Horizontal Mixing Box Dimensions – Left Hand Unit Sizes 006–020 and Right Hand Unit Sizes 030–050 – Bottom Filter Access

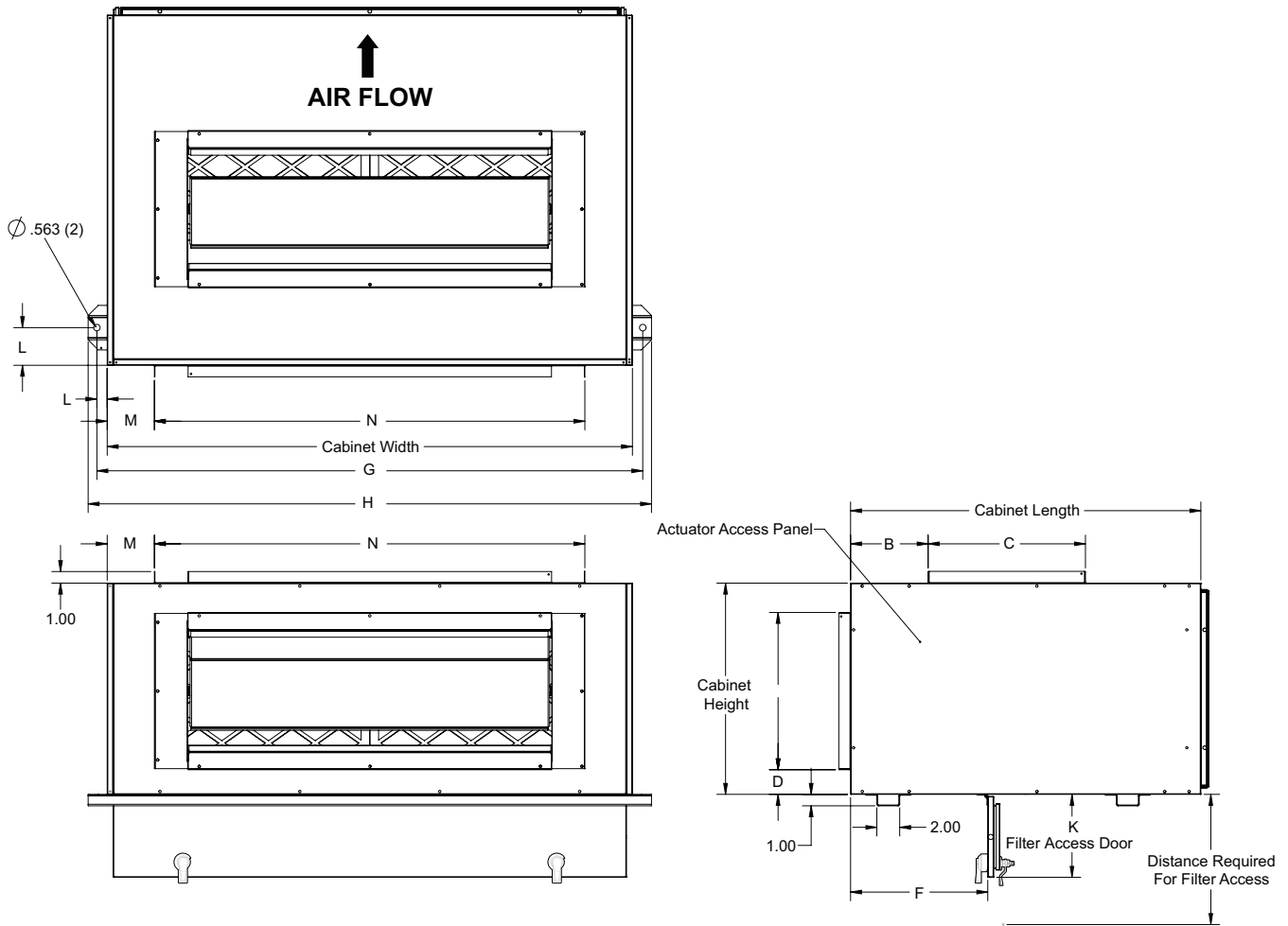

NOTE: Dimensions shown in inches.

Table 58: Mixing Box Dimension Letter Reference

Cabinet	006	008	010	012	016	018	020	030	040	050
B	6.64	6.64	6.64	6.64	6.64	6.64	6.64	5.54	5.54	5.54
C	13.47	13.47	13.47	13.47	13.47	13.47	13.47	18.39	18.39	18.39
D	2.11	2.11	2.11	2.11	2.11	2.11	2.11	3.80	5.80	6.80
E	13.47	13.47	13.47	13.47	13.47	13.47	13.47	18.39	18.39	18.39
F	11.62	11.62	11.62	11.62	11.62	11.62	11.62	19.56	17.86	17.36
G	16.75	21.75	29.75	29.75	38.25	46.75	46.75	51.00	56.00	63.00
H	18.25	23.25	31.25	31.25	39.75	48.25	48.25	52.50	57.50	64.50
J	3.22	3.22	3.22	3.22	3.22	3.22	3.22	3.22	3.22	3.22
K	7.00	7.00	7.00	7.00	7.00	7.00	7.00	7.00	7.00	7.00
L	0.87	0.87	0.87	0.87	0.87	0.87	0.87	1.00	1.00	1.00
M	0.98	2.66	2.29	2.29	2.80	4.04	4.04	6.32	3.82	2.82
N	10.18	14.66	23.41	30.90	30.90	36.87	36.87	36.34	46.34	55.34

NOTE: Dimensions shown in inches.

Figure 43: Horizontal Discharge Plenum (Unit Sizes 006-050)

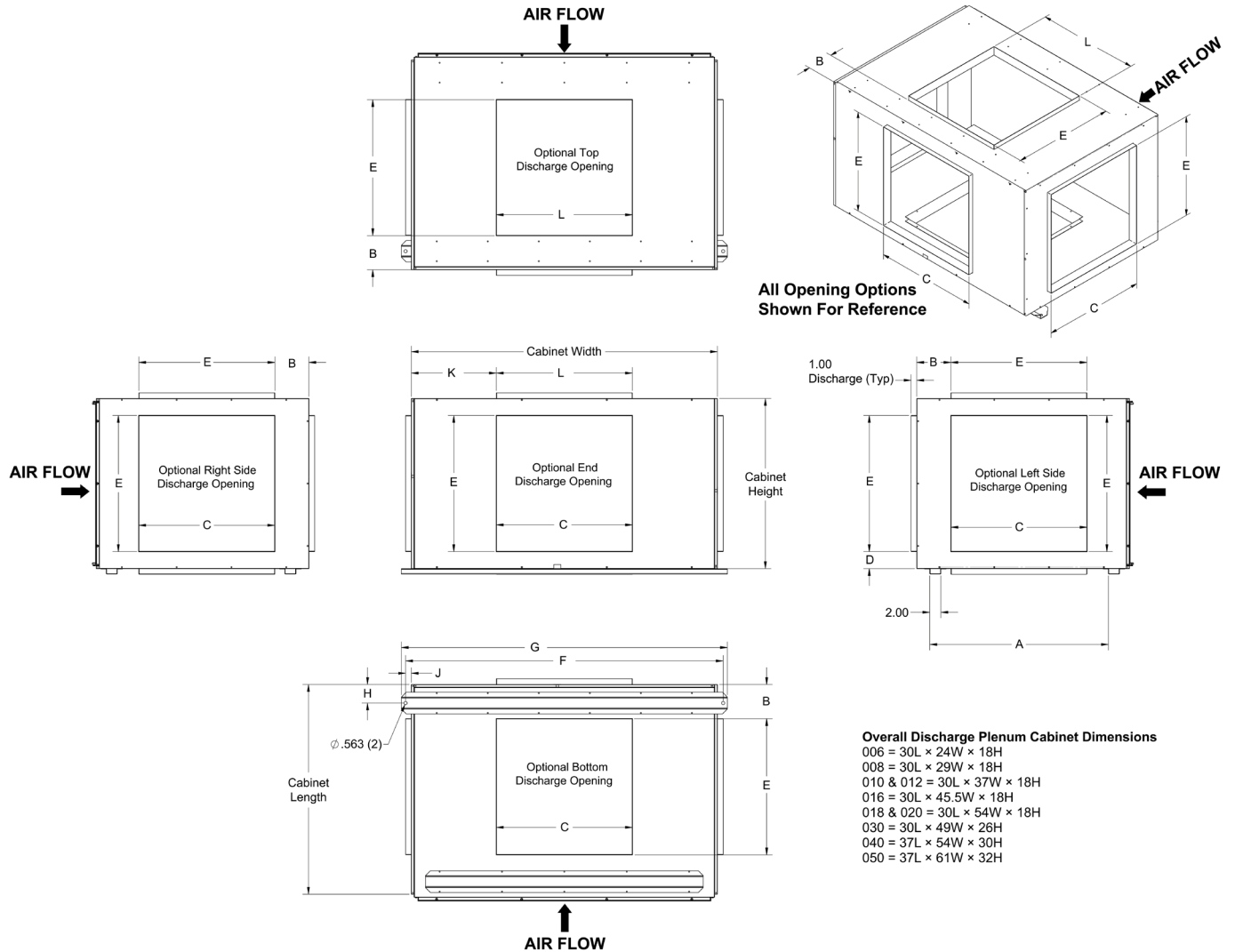

NOTE 1: Dimensions shown in inches.

NOTE 2: Discharge opening is offered on any particular side, but is shown here on all available surfaces for dimensioning purposes only.

NOTE 3: A discharge plenum is also available without discharge openings.

Table 59: Discharge Plenum Dimension Letter Reference

Cabinet	006	008	010	012	016	018	020	030	040	050
A	22.00	22.00	22.00	22.00	22.00	22.00	22.00	24.50	31.50	32.88
B	6.56	6.10	6.56	6.56	6.56	6.56	6.56	5.53	6.02	5.06
C	12.00	12.00	14.00	14.00	16.00	20.00	20.00	24.00	24.00	28.00
D	5.00	3.00	2.00	2.00	2.00	2.00	2.00	3.00	3.00	2.00
E	8.00	12.00	14.00	14.00	14.00	14.00	14.00	20.00	24.00	28.00
F	26.00	30.00	39.00	39.00	48.00	56.00	56.00	50.50	56.00	62.50
G	27.50	31.50	40.50	40.50	49.50	57.50	57.50	52.00	57.50	64.00
H	3.25	3.25	3.25	3.25	3.25	3.25	3.25	3.25	3.25	2.63
J	1.00	0.50	1.00	1.00	1.25	1.00	1.00	0.75	1.00	0.75
K	6.00	8.50	11.50	11.50	14.75	17.00	17.00	12.50	15.00	16.50
L	12.00	12.00	14.00	14.00	16.00	20.00	20.00	24.00	24.00	28.00

NOTE 1: Dimensions shown in inches.

NOTE 2: Discharge opening is offered on any one particular side, but is shown here on all available surfaces for dimensioning purposes only. A discharge plenum is also available without discharge openings.

Size 006-050 Vertical Unit Dimensions

Figure 44: Left-Hand, Single and Dual Fan (Unit Sizes 006-020)

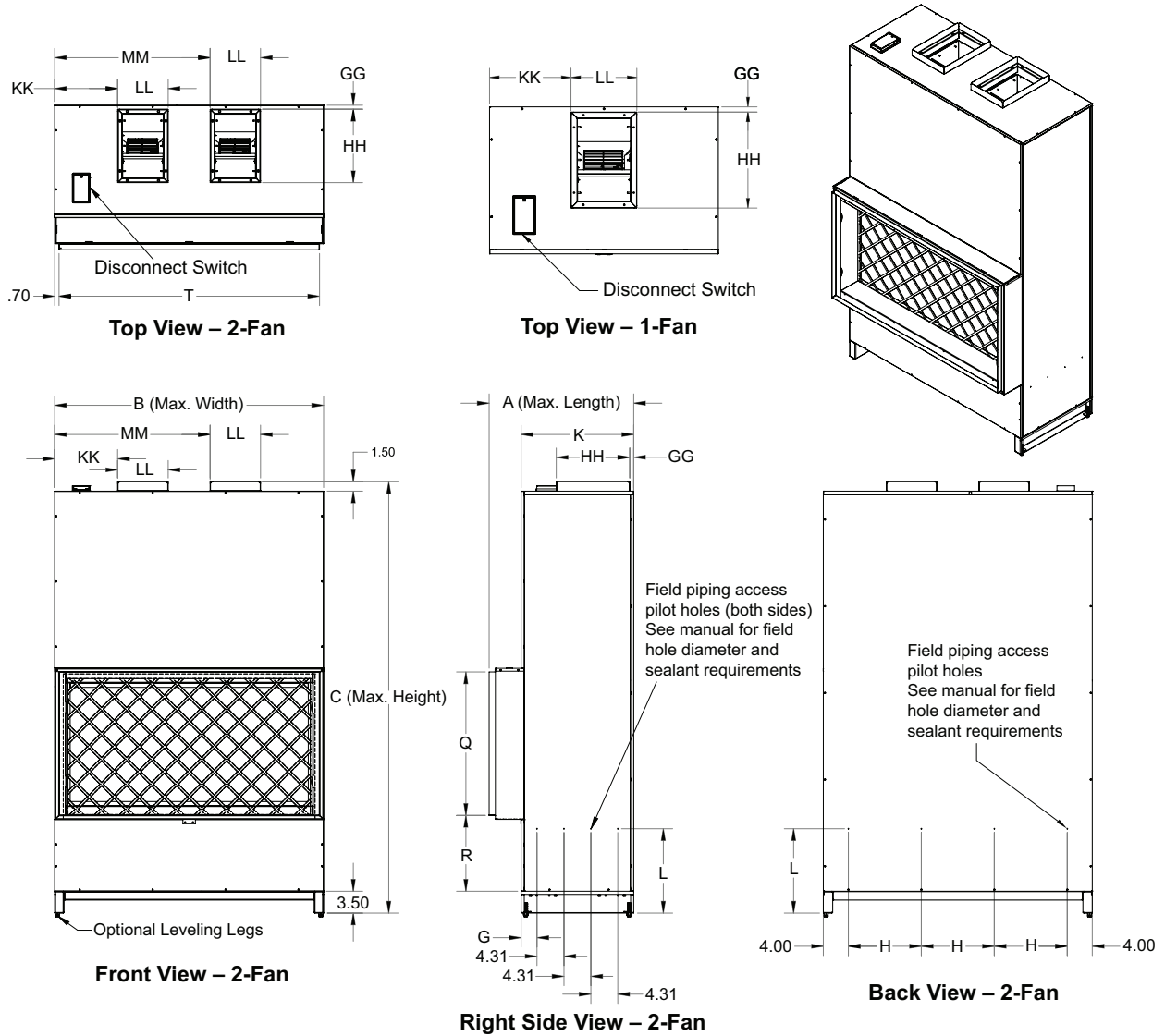

NOTE 1: Dimensions shown in inches.

NOTE 2: Unit Sizes 006 - 012 have 1 outlet while unit sizes 016-020 have 2.

Table 60: Dimension Letter Reference

Internal Filter Dimensions (in)																				
Size	A	B	C	G	H	K	L	Q	R	S	U	V	W	X	MM	KK	LL	GG	HH	
006	18.00	25.00	60.00	2.54	5.65	N/A	13.50	15.88	11.50	3.50	10.86	4.76	2.81	2.85	N/A	8.47	8.06	0.63	11.75	
008	18.00	28.00	65.00	2.54	6.65	N/A	13.50	19.04	11.50	3.50	10.86	4.76	2.81	2.85	N/A	9.97	8.06	0.63	11.75	
012	18.00	31.50	67.00	2.54	7.83	N/A	13.50	21.75	11.50	3.50	10.86	4.76	2.81	2.85	N/A	11.72	8.06	0.63	11.75	
016	18.00	38.00	68.5	2.54	10.00	N/A	13.50	24.19	11.50	3.50	10.86	4.76	2.81	2.85	24.86	9.45	8.06	0.63	11.75	
020	18.00	43.00	69.00	2.54	11.65	N/A	13.50	24.19	11.50	3.50	10.86	4.76	2.81	2.85	24.86	10.08	8.06	0.63	11.75	
External Filter Dimensions (in)																				
Size	A	B	C	G	H	K	L	Q	R	S	T	U	V	W	X	MM	KK	LL	GG	HH
006	23.07	25.00	60.00	2.54	5.65	18.00	13.50	14.78	12.09	3.50	23.63	10.86	4.76	2.81	2.85	N/A	8.47	8.06	0.63	11.75
008	23.07	28.00	65.00	2.54	6.65	18.00	13.50	17.85	12.09	3.50	26.63	10.86	4.76	2.81	2.85	N/A	9.97	8.06	0.63	11.75
012	23.07	31.50	67.00	2.54	7.83	18.00	13.50	20.63	12.09	3.50	30.18	10.86	4.76	2.81	2.85	N/A	11.72	8.06	0.63	11.75
016	23.07	38.00	68.5	2.54	10.00	18.00	13.50	23.00	12.09	3.50	36.63	10.86	4.76	2.81	2.85	24.86	9.45	8.06	0.63	11.75
020	23.07	43.00	69.00	2.54	11.65	18.00	13.50	23.00	12.09	3.50	41.63	10.86	4.76	2.81	2.85	24.86	10.08	8.06	0.63	11.75

Figure 45: Vertical Unit Dimensions (Unit Sizes 030-050)

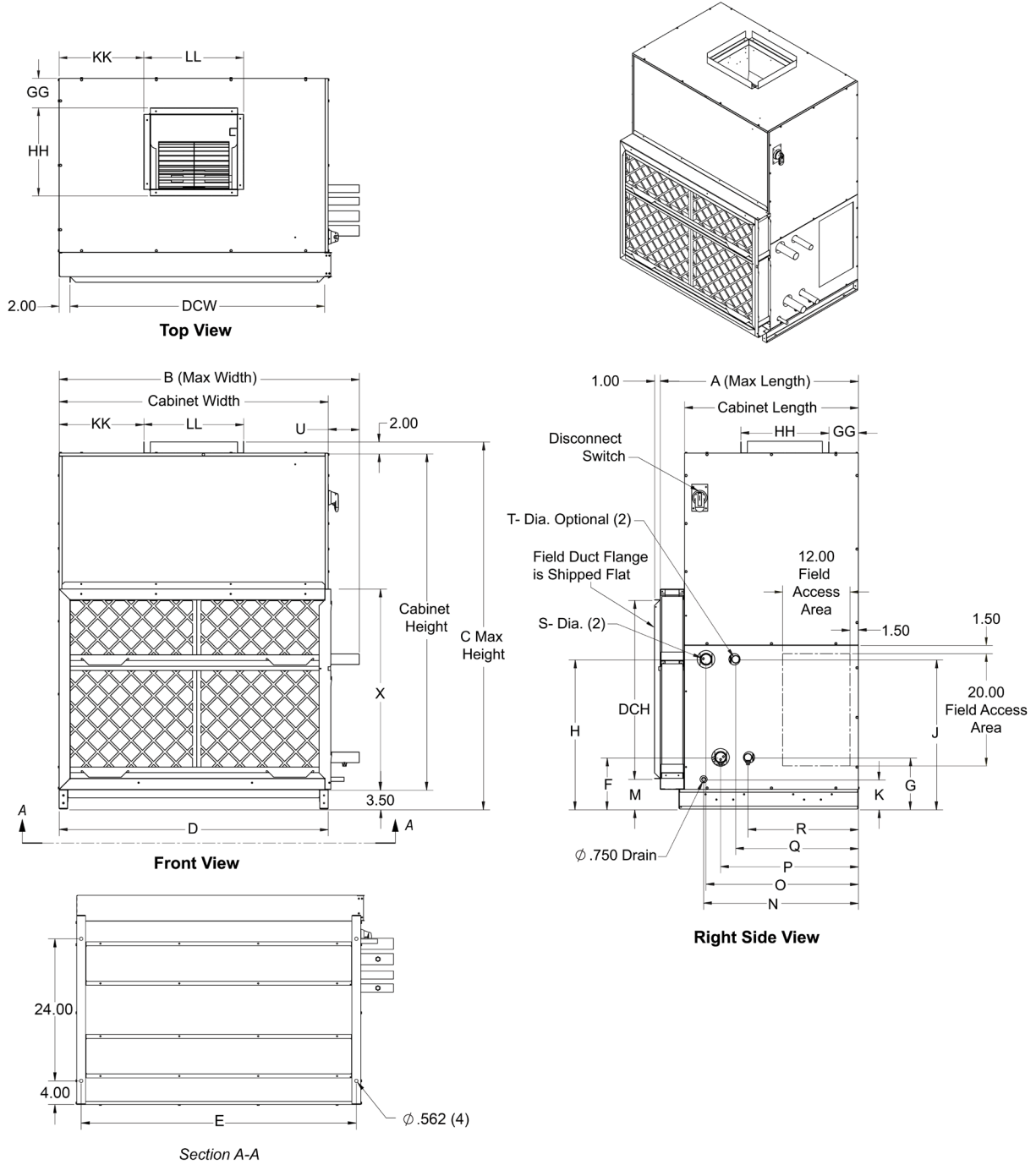

Cabinet Mounting Hole Locations

NOTE 1: Dimensions shown in inches.

NOTE 2: Right hand cabinet shown. Left hand similar but opposite.

Table 61: General Vertical Unit Dimensions for Figure 45 on page 77

Units with Forward-Curved Fans																
Unit Size	A	B	C	D	E	U	X	KK	LL	GG	HH	DCH	DCW	Cabinet Width	Cabinet Length	Cabinet Height
030	35.36	49.5	61.5	44	42.5	5.54	30.49	12.3	15.32	5.29	13.66	24.5	38	44	31	58
040	35.36	53.5	65.5	48	46.5	6	34.49	15.09	17.82	5.25	15.72	31.88	45.44	48	31	62
050	35.36	53.5	73.5	48	46.5	6	42.49	15.09	17.82	5.25	15.72	39.88	45.44	48	31	70
Units with Plenum Fans																
Unit Size	A	B	C	D	E	U	X	KK	LL	GG	HH	DCH	DCW	Cabinet Width	Cabinet Length	Cabinet Height
030	35.36	49.5	61.5	44	42.5	5.54	30.49	8.67	27.20	3.96	16.20	24.5	38	44	31	58
040	35.36	53.5	65.5	48	46.5	6	34.49	3.67	41.20	3.96	14.20	31.88	45.44	48	31	62
050	35.36	53.5	73.5	48	46.5	6	42.49	4.17	40.20	3.96	18.20	39.88	45.44	48	31	70

NOTE: Dimensions shown in inches.

Table 62: Vertical Coil Dimensions for Figure 45 on page 77

8 Row Coil RH (Cooling)													
Unit Size	K	F	H	G	J	M	N	O	P	Q	R	S	T
030	5.3	9.22	22.72	-	-	7.74	27.6	25.99	21.65	-	-	1.625	-
040	5.3	9.22	26.72	-	-	5.42	27.59	25.98	21.65	-	-	1.875	-
050	5.31	9.22	34.72	-	-	5.42	27.59	25.98	21.65	-	-	2.125	-
6 Row Coil RH (Cooling)													
Unit Size	K	F	H	G	J	M	N	O	P	Q	R	S	T
030	5.3	9.22	22.72	-	-	7.74	27.6	27.12	24.57	-	-	1.625	-
040	5.3	9.22	26.72	-	-	5.42	27.59	27.17	24.57	-	-	1.625	-
050	5.31	9.22	34.72	-	-	5.42	27.59	27.17	24.57	-	-	2.125	-
4 Row Coil RH (Cooling)													
Unit Size	K	F	H	G	J	M	N	O	P	Q	R	S	T
030	5.3	9.22	22.72	-	-	7.74	27.6	27.12	24.57	-	-	1.375	-
040	5.3	9.22	26.72	-	-	5.42	27.59	27.17	24.57	-	-	1.625	-
050	5.31	9.22	34.72	-	-	5.42	27.59	27.17	24.57	-	-	2.125	-
2 Row Coil RH (Cooling)													
Unit Size	K	F	H	G	J	M	N	O	P	Q	R	S	T
030	5.3	9.22	22.72	-	-	7.74	27.59	27.12	24.63	-	-	1.125	-
040	5.3	9.22	26.72	-	-	5.42	27.59	27.17	24.57	-	-	1.375	-
050	5.3	9.22	34.72	-	-	5.42	27.59	27.17	24.57	-	-	2.125	-
6 + 1 Rows Coil RH (Re-heat)													
Unit Size	K	F	H	G	J	M	N	O	P	Q	R	S	T
030	5.3	9.22	22.72	9.22	22.72	7.74	27.6	27.12	24.57	21.89	19.68	1.625	0.625
040	5.3	9.22	26.72	9.22	26.72	5.42	27.59	27.17	24.57	21.89	19.68	1.625	0.875
050	5.31	9.22	34.72	9.22	34.72	5.42	27.59	27.17	24.57	21.89	19.69	2.125	1.375
4 + 1 Rows Coil RH (Re-heat)													
Unit Size	K	F	H	G	J	M	N	O	P	Q	R	S	T
030	5.3	9.22	22.72	9.22	22.72	7.74	27.6	27.12	24.57	21.89	19.68	1.375	0.625
040	5.3	9.22	26.72	9.22	26.72	5.42	27.59	27.17	24.57	21.89	19.68	1.625	0.875
050	5.31	9.22	34.72	9.22	34.72	5.42	27.59	27.17	24.57	21.89	19.69	2.125	1.375
2 + 1 Rows Coil RH (Re-heat)													
Unit Size	K	F	H	G	J	M	N	O	P	Q	R	S	T
030	5.3	9.22	22.72	9.22	22.72	7.74	27.6	27.1	24.63	21.89	19.68	1.125	0.625
040	5.3	9.22	26.72	9.22	26.72	5.42	27.59	27.17	24.57	21.89	19.68	1.375	0.875
050	5.3	9.22	34.72	9.22	34.72	5.42	27.59	27.17	24.57	21.89	19.69	2.125	1.375
6 + 2 Rows Coil RH (Re-heat)													
Unit Size	K	F	H	G	J	M	N	O	P	Q	R	S	T
030	5.3	9.22	22.72	9.22	22.72	7.74	27.6	27.12	24.57	22.02	19.55	1.625	1.125
040	5.3	9.22	26.72	9.22	26.72	5.42	27.59	27.17	24.57	22.09	19.49	1.625	1.375
050	5.31	9.22	34.72	9.22	34.72	5.42	27.59	27.17	24.57	22.09	19.5	2.125	1.375
4 + 2 Rows Coil RH (Re-heat)													
Unit Size	K	F	H	G	J	M	N	O	P	Q	R	S	T
030	5.3	9.22	22.72	9.22	22.72	7.74	27.6	27.12	24.57	22.02	19.55	1.375	1.125
040	5.3	9.22	26.72	9.22	26.72	5.42	27.59	27.17	24.57	22.09	19.49	1.625	1.375
050	5.31	9.22	34.72	9.22	34.72	5.42	27.59	27.17	24.57	22.09	19.5	2.125	1.375

NOTE: Dimensions shown in inches.

DAIKIN APPLIED

Table 63: Vertical Coil Dimensions for Figure 45 on page 77 (continued)

2 + 2 Rows Coil RH (Re-heat)													
Unit Size	K	F	H	G	J	M	N	O	P	Q	R	S	T
030	5.3	9.22	22.72	9.22	22.72	7.74	27.6	27.1	24.63	22.02	19.55	1.125	1.125
040	5.3	9.22	26.72	9.22	26.72	5.42	27.59	27.17	24.57	22.09	19.49	1.375	1.375
050	5.3	9.22	34.72	9.22	34.72	5.42	27.59	27.17	24.57	22.09	19.5	2.125	1.125
1 + 6 Rows Coil RH (Pre-heat)													
Unit Size	K	F	H	G	J	M	N	O	P	Q	R	S	T
030	5.3	9.22	22.72	9.22	22.72	7.74	27.6	27.95	25.75	23.07	20.47	1.625	0.625
040	5.3	9.22	26.72	9.22	26.72	5.42	27.59	27.95	25.75	23.07	20.47	1.625	0.875
050	5.3	9.22	34.72	9.22	34.72	5.42	27.95	27.59	25.75	23.07	20.47	2.125	1.375
1 + 4 Rows Coil RH (Pre-heat)													
Unit Size	K	F	H	G	J	M	N	O	P	Q	R	S	T
030	5.3	9.22	22.72	9.22	22.72	7.74	27.6	27.95	25.75	23.07	20.47	1.375	0.625
040	5.3	9.22	26.72	9.22	26.72	5.42	27.59	27.95	25.75	23.07	20.47	1.625	0.875
050	5.3	9.22	34.72	9.22	34.72	5.42	28.15	27.59	25.56	23.07	20.47	2.125	1.375
1 + 2 Rows Coil RH (Pre-heat)													
Unit Size	K	F	H	G	J	M	N	O	P	Q	R	S	T
030	5.3	9.22	22.72	9.22	22.72	7.74	27.6	27.95	25.75	23	20.53	1.125	0.625
040	5.3	9.22	26.72	9.22	26.72	5.42	27.59	27.95	25.75	23.07	20.47	1.375	0.875
050		9.22	34.72	9.22	34.72	5.42	28.15	27.59	25.56	23.07	20.47	2.125	1.375
2 + 6 Rows Coil RH (Pre-heat)													
Unit Size	K	F	H	G	J	M	N	O	P	Q	R	S	T
030	5.3	9.22	22.72	9.22	22.72	7.74	27.6	28.09	25.61	23.07	20.47	1.625	1.125
040	5.3	9.22	26.72	9.22	26.72	5.42	27.59	28.15	25.55	23.07	20.47	1.625	1.375
050	5.3	9.22	34.72	9.22	34.72	5.42	28.15	27.59	25.56	23.07	20.47	2.125	1.375
2 + 4 Rows Coil RH (Pre-heat)													
Unit Size	K	F	H	G	J	M	N	O	P	Q	R	S	T
030	5.3	9.22	22.72	9.22	22.72	7.74	27.6	28.09	25.61	23.07	20.47	1.375	1.125
040	5.3	9.22	26.72	9.22	26.72	5.42	27.59	28.15	25.55	23.07	20.47	1.625	1.375
050	5.3	9.22	34.72	9.22	34.72	5.42	28.15	27.59	25.56	23.07	20.47	2.125	1.375
2 + 2 Rows Coil RH (Pre-heat)													
Unit Size	K	F	H	G	J	M	N	O	P	Q	R	S	T
030	5.3	9.22	22.72	9.22	22.72	7.74	27.6	28.09	25.61	23	20.53	1.125	1.125
040	5.3	9.22	26.72	9.22	26.72	5.42	27.59	28.15	25.55	23.07	20.47	1.375	1.375
050	5.3	9.22	34.72	9.22	34.72	5.42	28.15	27.59	25.56	23.07	20.47	2.125	1.375
1 + DX Single 3 Rows Coil RH (Re-Heat)													
Unit Size	K	F	H	G	J	M	N	O	P	Q	R	S	T
030	5.3	9.84	-	9.22	22.72	7.74	27.59	-	26.73	21.89	19.68	1.625	-
040	5.3	9.84	-	9.22	26.72	5.42	27.59	-	26.73	21.89	19.68	1.625	-
050	5.3	9.84	-	9.22	34.72	5.42	27.59	-	26.73	21.89	19.69	1.625	-
2 + DX Single 3 Rows Coil RH (Re-Heat)													
Unit Size	K	F	H	G	J	M	N	O	P	Q	R	S	T
030	5.3	9.84	-	9.22	22.72	7.74	27.59	-	26.73	22.02	19.55	1.625	-
040	5.3	9.84	-	9.22	26.72	5.42	27.59	-	26.73	22.09	19.49	1.625	-
050	5.3	9.84	-	9.22	34.72	5.42	27.59	-	26.73	22.09	19.5	1.625	-
1 + DX Interlace 3 Rows Coil RH (Re-Heat)													
Unit Size	K	F	H	G	J	M	N	O	P	Q	R	S	T
030	5.3	9.84	14.47	9.22	22.72	7.74	27.59	27.56	25.42	21.89	19.68	0.875	-
040	5.3	11.84	10.47	9.22	26.72	5.42	27.59	27.69	25.14	21.89	19.68	1.375	-
050	5.3	11.84	10.47	9.22	34.72	5.42	27.59	27.72	25.17	21.89	19.69	1.375	-

NOTE: Dimensions shown in inches.

Table 64: Vertical Coil Dimensions for Figure 45 on page 77 (continued)

2 + DX Interlace 3 Rows Coil RH (Re-Heat)													
Unit Size	K	F	H	G	J	M	N	O	P	Q	R	S	T
030	5.3	9.84	14.47	9.22	22.72	7.74	27.59	27.56	25.42	22.02	19.55	0.875	-
040	5.3	11.84	10.47	9.22	26.72	5.42	27.59	27.69	25.14	22.09	19.49	1.375	-
050	5.3	11.84	10.47	9.22	34.72	5.42	27.59	27.72	25.17	22.09	19.5	1.375	-
1 + DX Interlace 6 Rows Coil RH (Re-Heat)													
Unit Size	K	F	H	G	J	M	N	O	P	Q	R	S	T
030	5.3	14.22	10.47	9.22	22.72	7.74	27.59	27.12	24.97	21.89	19.68	1.125	-
040	5.3	8.84	10.47	9.22	26.72	5.42	27.59	27.03	24.85	21.89	19.68	1.325	-
050	5.3	8.84	10.47	9.22	34.72	5.42	27.59	26.73	24.61	21.89	19.69	1.625	-
2 + DX Interlace 6 Rows Coil RH (Re-Heat)													
Unit Size	K	F	H	G	J	M	N	O	P	Q	R	S	T
030	5.3	14.22	14.22	9.22	22.72	7.74	27.59	27.12	24.97	22.02	19.55	1.125	-
040	5.3	8.84	10.47	9.22	26.72	5.42	27.59	27.03	24.85	22.09	19.49	1.325	-
050	5.3	8.84	10.47	9.22	34.72	5.42	27.59	26.73	24.61	22.09	19.5	1.625	-
1 + DX Single 3 Rows Coil RH (Pre-Heat)													
Unit Size	K	F	H	G	J	M	N	O	P	Q	R	S	T
030	5.3	9.22	22.72	-	9.84	7.74	27.59	27.95	25.75	22.64	-	1.125	-
040	5.3	9.22	26.72	-	9.84	5.42	27.59	27.95	25.75	22.64	-	0.875	-
050	5.3	9.22	34.72	-	9.84	5.42	27.59	27.59	25.75	22.64	-	1.375	-
2 + DX Single 3 Rows Coil RH (Pre-Heat)													
Unit Size	K	F	H	G	J	M	N	O	P	Q	R	S	T
030	5.3	9.22	22.72	-	9.84	7.74	27.59	28.09	25.61	22.64	-	1.125	-
040	5.3	9.22	26.72	-	9.84	5.42	27.59	28.15	25.55	22.64	-	0.875	-
050	5.3	9.22	34.72	-	9.84	5.42	27.59	27.59	25.56	22.64	-	1.375	-
1 + DX Interlace 3 Rows Coil RH (Pre-Heat)													
Unit Size	K	F	H	G	J	M	N	O	P	Q	R	S	T
030	5.31	9.22	22.72	9.84	14.47	7.74	27.59	27.95	25.75	23.46	21.32	0.625	0.875
040	5.31	9.22	26.72	11.84	10.47	5.42	27.59	27.95	25.75	23.62	21.07	0.875	1.375
050	5.31	9.22	34.72	11.84	10.47	5.42	27.59	27.59	25.75	23.62	21.07	1.375	1.375
2 + DX Interlace 3 Rows Coil RH (Pre-Heat)													
Unit Size	K	F	H	G	J	M	N	O	P	Q	R	S	T
030	5.31	9.22	22.72	9.84	14.47	7.74	27.59	28.09	25.61	23.46	21.32	0.625	0.875
040	5.31	9.22	26.72	11.84	10.47	5.42	27.59	28.15	25.55	23.62	21.07	0.875	1.375
050	5.31	9.22	34.72	11.84	10.47	5.42	27.59	27.59	25.56	23.62	21.07	1.375	1.375
1 + DX Interlace 6 Rows Coil RH (Pre-Heat)													
Unit Size	K	F	H	G	J	M	N	O	P	Q	R	S	T
030	5.31	9.22	22.72	14.22	10.47	7.74	27.59	27.95	25.75	23.46	21.32	0.625	0.875
040	5.31	9.22	26.72	8.84	10.47	5.42	27.59	27.95	25.75	23.62	21.07	0.875	1.375
050	5.31	9.22	34.72	8.84	10.47	5.42	27.59	27.59	25.75	23.62	21.07	1.375	1.375
2 + DX Interlace 6 Rows Coil RH (Pre-Heat)													
Unit Size	K	F	H	G	J	M	N	O	P	Q	R	S	T
030	5.31	9.22	22.72	14.22	10.47	7.74	27.59	28.09	25.61	23.46	21.32	0.625	0.875
040	5.31	9.22	26.72	8.84	10.47	5.42	27.59	28.15	25.55	23.62	21.07	0.875	1.375
050	5.31	9.22	34.72	8.84	10.47	5.42	27.59	27.59	25.56	23.62	21.07	1.375	1.375
Steam Coils													
Unit Size	K	F	H	G	J	M	N	O	P	Q	R	S	T
030	5.31	-	-	9.67	21.71	-	-	-	-	25.72	28.03		1.125
040	5.31	-	-	9.58	23.71	-	-	-	-	25.72	28.03		1.125
050	5.31	-	-	9.84	27.71	-	-	-	-	25.82	27.97		1.375

NOTE: Dimensions shown in inches.

Figure 46: Vertical Mixing Box - Top and End Damper, Unit Sizes 030-050 - Side Filter Access

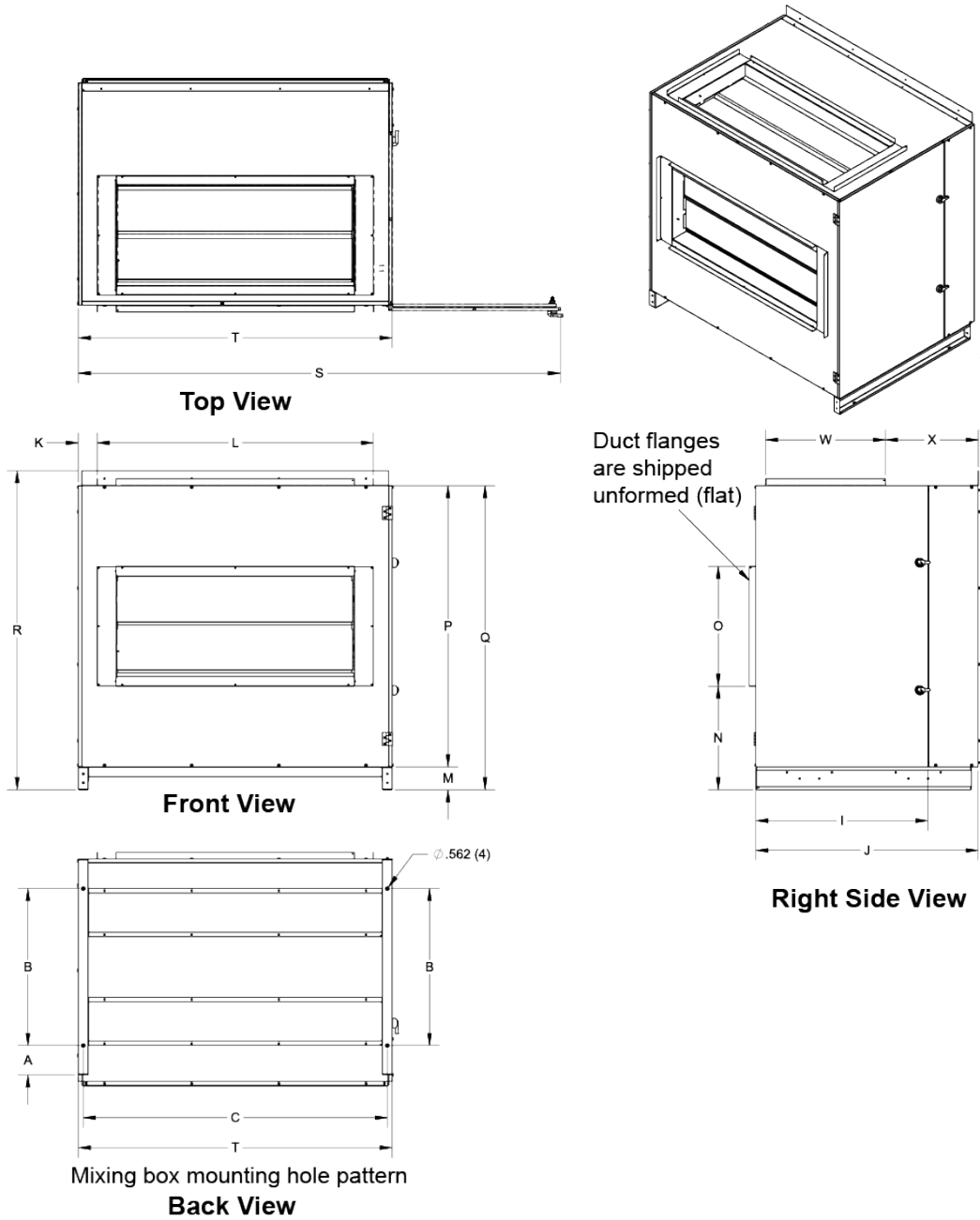

NOTE: Dimensions shown in inches.

Table 65: Mixing Box Dimension Letter Reference

Vertical Mixing Box																		
Unit Size	A	B	C	D	I	J	K	L	M	N	O	P	Q	R	S	T	W	X
030	5.5	24	42.5	44	26.31	33	2.87	38.27	3.5	9.82	18.37	31	34.5	36.76	70.12	34	18.37	14.19
040	5.5	24	46.5	48	26.31	33	2.87	42.31	3.5	11.82	18.37	35	38.5	40.76	74.12	34	18.37	14.19
050	5.5	24	46.5	48	26.31	33	2.87	42.31	3.5	15.82	18.37	43	46.5	48.76	74.12	34	18.37	14.19

NOTE: Dimensions shown in inches.

Figure 47: Vertical Discharge Plenum (Unit Sizes 006-050)

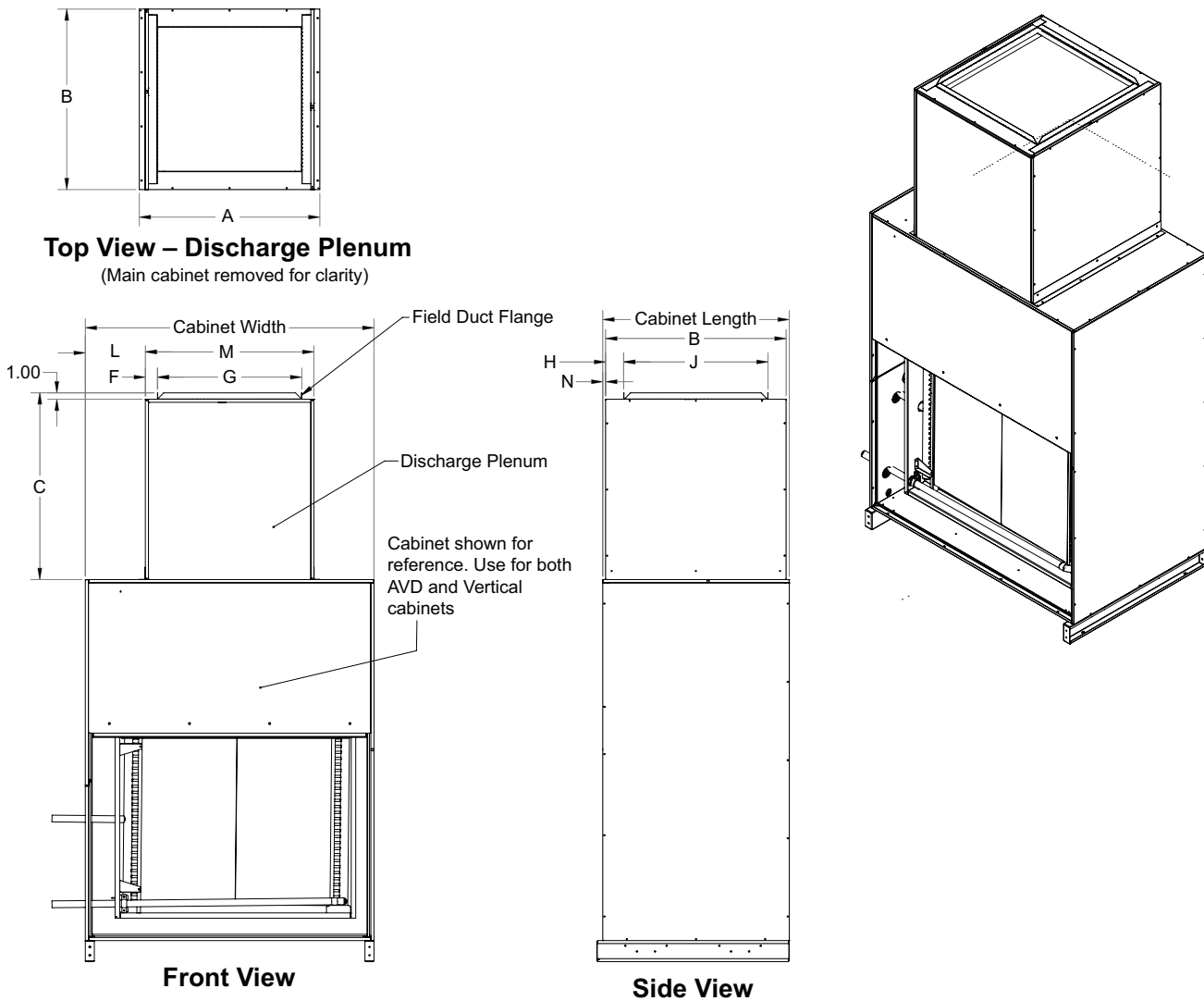

NOTE: Dimensions shown in inches.

Table 66: Discharge Plenum Dimension Letter Reference

AVD													
Unit Size	A	B	C	F	G	H	J	L	M	N	Cabinet Length	Cabinet Width	Cabinet Height
006	14.00	17.50	25.00	2.00	8.06	2.75	12.00	6.50	12.00	0.25	18.00	25.00	58.00
008	18.00	17.50	25.00	2.00	12.00	2.75	12.00	6.00	16.00	0.25	18.00	28.00	60.00
012	20.00	17.50	25.00	2.00	14.00	2.75	12.00	6.75	18.00	0.25	18.00	31.50	62.00
016	31.00	17.50	25.00	5.47	20.00	1.75	14.00	6.75	29.00	0.25	18.00	38.00	63.50
020	33.00	17.50	25.00	2.47	20.00	1.75	14.00	6.00	31.00	0.25	18.00	43.00	64.00
Vertical													
Unit Size	A	B	C	F	G	H	J	L	M	N	Cabinet Length	Cabinet Width	Cabinet Height
030	26.00	30.00	31.00	2.00	20.00	5.00	20.00	10.00	24.00	0.50	31.00	44.00	56.00
040	30.00	30.00	31.00	2.00	24.00	3.00	24.00	10.00	28.00	0.50	31.00	48.00	60.00
050	30.00	30.00	31.00	2.00	24.00	3.00	24.00	10.00	28.00	0.50	31.00	48.00	68.00

NOTE: Dimensions shown in inches.

Size 060-100 Unit Dimensions

Figure 48: Horizontal Unit Coil Section Dimensions (Unit Sizes 060-100)

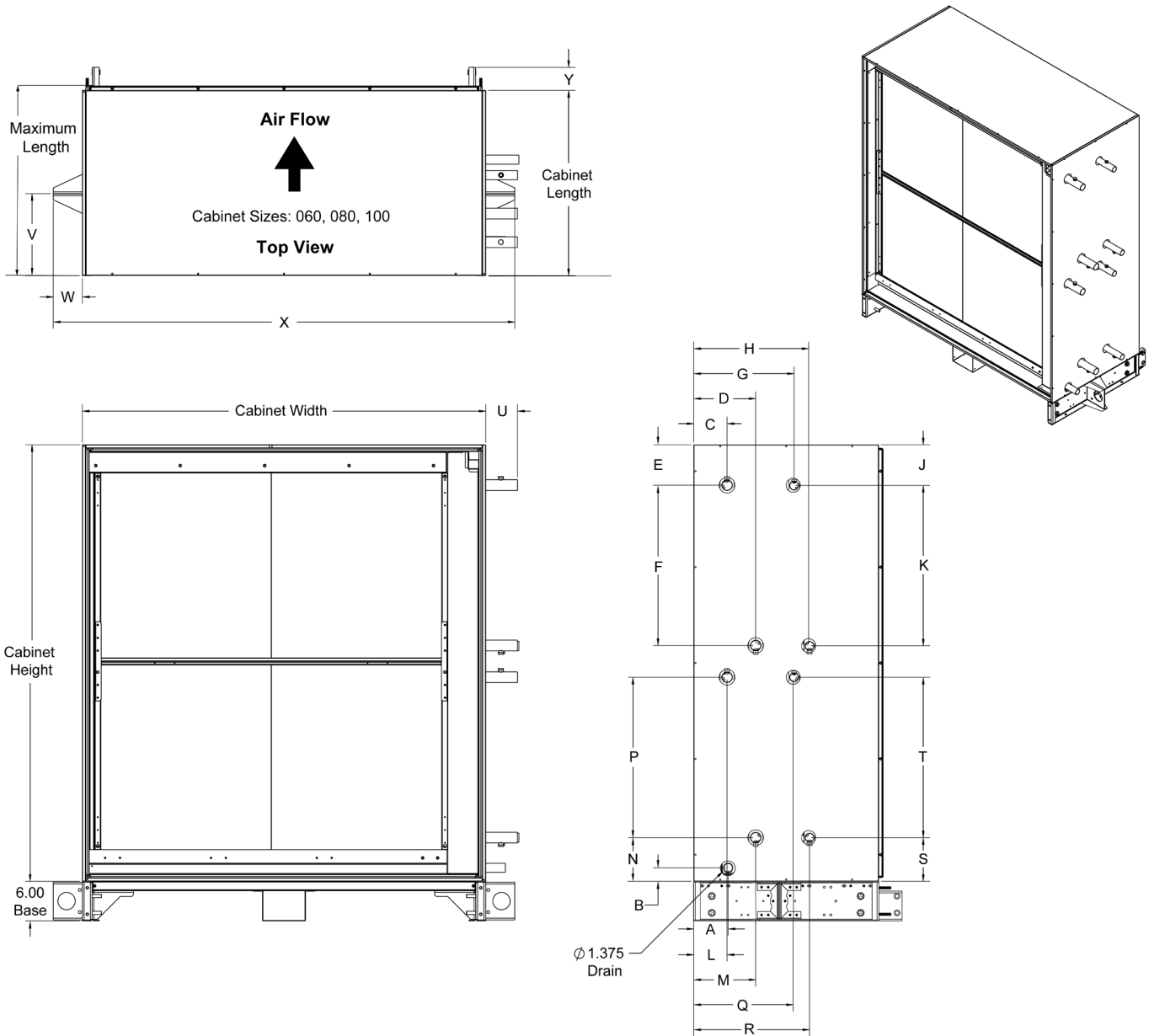

NOTE: Dimensions shown in inches.

Table 67: General Unit Dimensions (Unit Sizes 060-100)

Unit Size	Cabinet Length	Maximum Length	Width	Height	U	V	W	X	Y
060	28.00	28.66	54.00	54.00	4.19	12.39	4.38	62.75	3.50
080	28.00	28.66	54.00	62.00	5.45	12.39	4.38	62.75	3.50
100	28.00	28.66	61.00	66.00	4.79	12.39	4.38	69.75	3.50

NOTE: Dimensions shown in inches.

Table 68: Horizontal Hydronic Coil Unit Dimensions (Unit Sizes 060-100) for Figure 48 on page 83

8-Row Cold Water + 2-Row Hot Water																		
Unit Size	A	B	C	D	E	F	G	H	J	K	L	M	N	P	Q	R	S	T
060	-	-	5.01	9.37	6.11	18.25	15.75	17.29	6.11	18.25	5.01	9.37	6.59	18.25	15.75	17.29	6.59	18.25
080	-	-	5.03	9.36	6.11	22.25	15.75	17.29	6.11	22.25	5.03	9.36	6.59	22.25	15.75	17.29	6.59	22.25
100	5.20	2.03	5.03	9.36	6.11	24.25	15.17	17.50	6.11	24.25	5.03	9.36	6.59	24.25	15.17	17.50	6.59	24.25
6-Row Cold Water + 2-Row Hot Water																		
Unit Size	A	B	C	D	E	F	G	H	J	K	L	M	N	P	Q	R	S	T
060	-	-	6.24	8.84	6.11	18.25	15.75	17.29	6.11	18.25	6.24	8.84	6.59	18.25	15.75	17.29	6.59	18.25
080	-	-	6.24	8.83	6.11	22.25	15.75	17.29	6.11	22.25	6.24	8.83	6.59	22.25	15.75	17.29	6.59	22.25
100	5.20	2.03	6.23	8.84	6.11	24.25	15.17	17.50	6.11	24.25	6.23	8.84	6.59	24.25	15.17	17.50	6.59	24.25
4-Row Cold Water + 2-Row Hot Water																		
Unit Size	A	B	C	D	E	F	G	H	J	K	L	M	N	P	Q	R	S	T
060	-	-	6.24	8.83	6.11	18.25	15.75	17.29	6.11	18.25	6.24	8.83	6.59	18.25	15.75	17.29	6.59	18.25
080	-	-	5.36	7.96	6.11	22.25	15.75	17.29	6.11	22.25	5.36	7.96	6.59	22.25	15.75	17.29	6.59	22.25
100	5.20	2.03	6.24	8.83	6.11	24.25	15.17	17.50	6.11	24.25	6.24	8.83	6.59	24.25	15.17	17.50	6.59	24.25
2-Row Cold Water + 2-Row Hot Water																		
Unit Size	A	B	C	D	E	F	G	H	J	K	L	M	N	P	Q	R	S	T
060	-	-	6.42	7.97	6.11	18.25	15.75	17.29	6.11	18.25	6.42	7.97	6.59	18.25	15.75	17.29	6.59	18.25
080	-	-	6.42	7.97	6.11	22.25	15.75	17.29	6.11	22.25	6.42	7.97	6.59	22.25	15.75	17.29	6.59	22.25
100	5.20	2.03	5.96	7.97	6.11	24.25	15.17	17.50	6.11	24.25	5.96	7.97	6.59	24.25	15.17	17.50	6.59	24.25
8-Row Cold Water + 1-Row Hot Water																		
Unit Size	A	B	C	D	E	F	G	H	J	K	L	M	N	P	Q	R	S	T
060	-	-	5.01	9.37	6.11	18.25	15.63	16.84	6.11	18.39	5.01	9.37	6.59	18.25	15.63	16.84	6.45	18.39
080	-	-	5.03	9.36	6.11	22.25	15.49	16.84	7.61	19.75	5.03	9.36	6.59	22.25	15.49	16.84	7.59	19.75
100	5.20	2.03	5.03	9.36	6.11	24.25	15.39	16.84	6.11	24.25	5.03	9.36	6.59	24.25	15.39	16.84	6.59	24.25
6-Row Cold Water + 1-Row Hot Water																		
Unit Size	A	B	C	D	E	F	G	H	J	K	L	M	N	P	Q	R	S	T
060	-	-	6.24	8.84	6.11	18.25	15.63	16.84	6.11	18.39	6.24	8.84	6.59	18.25	15.63	16.84	6.45	18.39
080	-	-	6.24	8.83	6.11	22.25	15.48	16.83	7.61	19.75	6.24	8.83	6.59	22.25	15.48	16.83	7.59	19.75
100	5.20	2.03	6.23	8.84	6.11	24.25	15.39	16.84	6.11	24.25	6.23	8.84	6.59	24.25	15.39	16.84	6.59	24.25
4-Row Cold Water + 1-Row Hot Water																		
Unit Size	A	B	C	D	E	F	G	H	J	K	L	M	N	P	Q	R	S	T
060	-	-	6.24	8.83	6.11	18.25	15.63	16.84	6.11	18.39	6.24	8.83	6.59	18.25	15.63	16.84	6.45	18.39
080	-	-	5.36	7.96	6.11	22.25	15.48	16.83	7.61	19.75	5.36	7.96	6.59	22.25	15.48	16.83	7.59	19.75
100	5.20	2.03	6.24	8.83	6.11	24.25	15.39	16.84	6.11	24.25	6.24	8.83	6.59	24.25	15.39	16.84	6.59	24.25
2-Row Cold Water + 1-Row Hot Water																		
Unit Size	A	B	C	D	E	F	G	H	J	K	L	M	N	P	Q	R	S	T
060	-	-	6.42	7.97	6.11	18.25	15.63	16.84	6.11	18.39	6.42	7.97	6.59	18.25	15.63	16.84	6.45	18.39
080	-	-	6.42	7.97	6.11	22.25	15.48	16.83	7.61	19.75	6.42	7.97	6.59	22.25	15.48	16.83	7.59	19.75
100	5.20	2.03	5.96	7.97	6.11	24.25	15.39	16.84	6.11	24.25	5.96	7.97	6.59	24.25	15.39	16.84	6.59	24.25
2-Row Hot Water + 8-Row Cold Water																		
Unit Size	A	B	C	D	E	F	G	H	J	K	L	M	N	P	Q	R	S	T
060	-	-	7.45	9.00	6.11	18.25	12.22	16.58	6.11	18.25	7.45	9.00	6.59	18.25	12.22	16.58	6.59	18.25
080	-	-	7.50	9.04	6.11	22.25	12.28	16.61	6.11	22.25	7.50	9.04	6.59	22.25	12.28	16.61	6.59	22.25
100	5.20	2.03	6.92	9.25	6.11	24.25	12.28	16.61	6.11	24.25	6.92	9.25	6.59	24.25	12.28	16.61	6.59	24.25
2-Row Hot Water + 6-Row Cold Water																		
Unit Size	A	B	C	D	E	F	G	H	J	K	L	M	N	P	Q	R	S	T
060	-	-	7.45	9.00	6.11	18.25	13.45	16.05	6.11	18.25	7.45	9.00	6.59	18.25	13.45	16.05	6.59	18.25
080	-	-	7.50	9.04	6.11	22.25	13.49	16.08	6.11	22.25	7.50	9.04	6.59	22.25	13.49	16.08	6.59	22.25
100	5.20	2.03	6.92	9.25	6.11	24.25	13.48	16.09	6.11	24.25	6.92	9.25	6.59	24.25	13.48	16.09	6.59	24.25
2-Row Hot Water + 4-Row Cold Water																		
Unit Size	A	B	C	D	E	F	G	H	J	K	L	M	N	P	Q	R	S	T
060	-	-	7.45	9.00	6.11	18.25	13.45	16.04	6.11	18.25	7.45	9.00	6.59	18.25	13.45	16.04	6.59	18.25
080	-	-	7.50	9.04	6.11	22.25	12.61	15.21	6.11	22.25	7.50	9.04	6.59	22.25	12.61	15.21	6.59	22.25
100	5.20	2.03	6.92	9.25	6.11	24.25	13.49	16.08	6.11	24.25	6.92	9.25	6.59	24.25	13.49	16.08	6.59	24.25
2-Row Hot Water + 2-Row Cold Water																		
Unit Size	A	B	C	D	E	F	G	H	J	K	L	M	N	P	Q	R	S	T
060	-	-	7.45	9.00	6.11	18.25	13.63	15.18	6.11	18.25	7.45	9.00	6.59	18.25	13.63	15.18	6.59	18.25
080	-	-	7.50	9.04	6.11	22.25	13.67	15.22	6.11	22.25	7.50	9.04	6.59	22.25	13.67	15.22	6.59	22.25
100	5.20	2.03	6.92	9.25	6.11	24.25	13.21	15.22	6.11	24.25	6.92	9.25	6.59	24.25	13.21	15.22	6.59	24.25

1-Row Hot Water + 8-Row Cold Water																		
Unit Size	A	B	C	D	E	F	G	H	J	K	L	M	N	P	Q	R	S	T
060	-	-	7.34	8.55	6.11	18.39	12.22	16.58	6.11	18.25	7.34	8.55	6.45	18.39	12.22	16.58	6.59	18.25
080	-	-	7.23	8.58	7.61	19.75	12.28	16.61	6.11	22.25	7.23	8.58	7.59	19.75	12.28	16.61	6.59	22.25
100	5.20	2.03	7.14	8.59	6.11	24.25	12.28	16.61	6.11	24.25	7.14	8.59	6.59	24.25	12.28	16.61	6.59	24.25
1-Row Hot Water + 6-Row Cold Water																		
Unit Size	A	B	C	D	E	F	G	H	J	K	L	M	N	P	Q	R	S	T
060	-	-	7.34	8.55	6.11	18.39	13.45	16.05	6.11	18.25	7.34	8.55	6.45	18.39	13.45	16.05	6.59	18.25
080	-	-	7.23	8.58	7.61	19.75	13.49	16.08	6.11	22.25	7.23	8.58	7.59	19.75	13.49	16.08	6.59	22.25
100	5.20	2.03	7.14	8.59	6.11	24.25	13.48	16.09	6.11	24.25	7.14	8.59	6.59	24.25	13.48	16.09	6.59	24.25
1-Row Hot Water + 4-Row Cold Water																		
Unit Size	A	B	C	D	E	F	G	H	J	K	L	M	N	P	Q	R	S	T
060	-	-	7.34	8.55	6.11	18.39	13.45	16.04	6.11	18.25	7.34	8.55	6.45	18.39	13.45	16.04	6.59	18.25
080	-	-	7.23	8.58	7.61	19.75	12.61	15.21	6.11	22.25	7.23	8.58	7.59	19.75	12.61	15.21	6.59	22.25
100	5.20	2.03	7.14	8.59	6.11	24.25	13.49	16.08	6.11	24.25	7.14	8.59	6.59	24.25	13.49	16.08	6.59	24.25
1-Row Hot Water + 2-Row Cold Water																		
Unit Size	A	B	C	D	E	F	G	H	J	K	L	M	N	P	Q	R	S	T
060	-	-	7.34	8.55	6.11	18.39	13.63	15.18	6.11	18.25	7.34	8.55	6.45	18.39	13.63	15.18	6.59	18.25
080	-	-	7.23	8.58	7.61	19.75	13.67	15.22	6.11	22.25	7.23	8.58	7.61	19.75	13.67	15.22	6.59	22.25
100	5.20	2.03	7.14	8.59	6.11	24.25	13.21	15.22	6.11	24.25	7.14	8.59	6.59	24.25	13.21	15.22	6.59	24.25
8-Row																		
Unit Size	A	B	C	D	E	F	G	H	J	K	L	M	N	P	Q	R	S	T
060	-	-	5.01	9.37	6.11	18.25	-	-	-	-	5.01	9.37	6.59	18.25	-	-	-	-
080	-	-	5.03	9.36	6.11	22.25	-	-	-	-	5.03	9.36	6.59	22.25	-	-	-	-
100	5.20	2.03	5.03	9.36	6.11	24.25	-	-	-	-	5.03	9.36	6.59	24.25	-	-	-	-
6-Row																		
Unit Size	A	B	C	D	E	F	G	H	J	K	L	M	N	P	Q	R	S	T
060	-	-	6.24	8.84	6.11	18.25	-	-	-	-	6.24	8.84	6.59	18.25	-	-	-	-
080	-	-	6.24	8.83	6.11	22.25	-	-	-	-	6.24	8.83	6.59	22.25	-	-	-	-
100	5.20	2.03	6.23	8.84	6.11	24.25	-	-	-	-	6.23	8.84	6.59	24.25	-	-	-	-
4-Row																		
Unit Size	A	B	C	D	E	F	G	H	J	K	L	M	N	P	Q	R	S	T
060	-	-	6.24	8.83	6.11	18.25	-	-	-	-	6.24	8.83	6.59	18.25	-	-	-	-
080	-	-	5.36	7.96	6.11	22.25	-	-	-	-	5.36	7.96	6.59	22.25	-	-	-	-
100	5.20	2.03	6.24	8.83	6.11	24.25	-	-	-	-	6.24	8.83	6.59	24.25	-	-	-	-
2-Row																		
Unit Size	A	B	C	D	E	F	G	H	J	K	L	M	N	P	Q	R	S	T
060	-	-	6.42	7.97	6.11	18.25	-	-	-	-	6.42	7.97	6.59	18.25	-	-	-	-
080	-	-	6.42	7.97	6.11	22.25	-	-	-	-	6.42	7.97	6.59	22.25	-	-	-	-
100	5.20	2.03	5.96	7.97	6.11	24.25	-	-	-	-	5.96	7.97	6.59	24.25	-	-	-	-

NOTE: Dimensions shown in inches.

Table 69: Horizontal DX Unit Dimensions (Unit Sizes 060-100) for Figure 48 on page 83

DX Single + 2-Row Hot Water																		
Unit Size	A	B	C	D	E	F	G	H	J	K	L	M	N	P	Q	R	S	T
060	-	-	6.67	-	24.63	-	15.75	17.29	6.11	18.25	6.67	-	6.33	-	15.75	17.29	6.59	18.25
080	-	-	6.67	-	28.63	-	15.75	17.29	6.11	22.25	6.67	-	6.33	-	15.75	17.29	6.59	22.25
100	5.20	2.03	6.67	-	30.61	-	15.17	17.50	6.11	24.25	6.67	-	6.33	-	15.17	17.50	6.59	24.25
DX Single + 1-Row Hot Water																		
Unit Size	A	B	C	D	E	F	G	H	J	K	L	M	N	P	Q	R	S	T
060	-	-	6.67	-	24.63	-	15.63	16.84	6.11	18.39	6.67	-	6.33	-	15.63	16.84	6.45	18.39
080	-	-	6.67	-	28.63	-	15.48	16.83	7.61	19.75	6.67	-	6.33	-	15.48	16.83	7.59	19.75
100	5.20	2.03	6.67	-	30.61	-	15.39	16.84	6.11	24.25	6.67	-	6.33	-	15.39	16.84	6.59	24.25
DX Interlaced + 2-Row Hot Water																		
Unit Size	A	B	C	D	E	F	G	H	J	K	L	M	N	P	Q	R	S	T
060	-	-	6.67	7.98	19.63	4.00	15.75	17.29	6.11	18.25	6.67	7.98	7.33	4.00	15.75	17.29	6.59	18.25
080	-	-	6.66	8.10	23.63	4.00	15.75	17.29	6.11	22.25	6.66	8.10	7.33	4.00	15.75	17.29	6.59	22.25
100	5.20	2.03	5.11	8.23	27.61	2.00	15.17	17.50	6.11	24.25	5.11	8.23	9.33	2.00	15.17	17.50	7.33	24.25
DX Interlaced + 1-Row Hot Water																		
Unit Size	A	B	C	D	E	F	G	H	J	K	L	M	N	P	Q	R	S	T
060	-	-	6.67	7.98	19.63	4.00	15.63	16.84	6.11	18.39	6.67	7.98	7.33	4.00	15.63	16.84	6.45	18.39
080	-	-	6.66	8.10	23.63	4.00	15.48	16.83	7.61	19.75	6.66	8.10	7.33	4.00	15.48	16.83	7.59	19.75
100	5.20	2.03	5.11	8.23	27.61	2.00	15.39	16.84	6.11	24.25	5.11	8.23	9.33	2.00	15.39	16.84	7.33	24.25
2-Row Hot Water + DX Single																		
Unit Size	A	B	C	D	E	F	G	H	J	K	L	M	N	P	Q	R	S	T
060	-	-	7.45	9.00	6.11	18.25	-	13.88	-	24.63	7.45	9.00	6.59	18.25	-	13.88	6.33	-
080	-	-	7.50	9.04	6.11	22.25	13.92	-	28.63	-	7.50	9.04	6.59	22.25	13.92	-	6.33	-
100	5.20	2.03	6.92	9.25	6.11	24.25	13.92	-	30.63	-	6.92	9.25	6.59	24.25	13.92	-	6.33	-
1-Row Hot Water + DX Single																		
Unit Size	A	B	C	D	E	F	G	H	J	K	L	M	N	P	Q	R	S	T
060	-	-	7.34	8.55	6.11	18.39	-	13.88	-	24.63	7.34	8.55	6.45	18.39	-	13.88	6.33	-
080	-	-	7.23	8.58	7.61	19.75	13.92	-	28.63	-	7.23	8.58	7.59	19.75	13.92	-	6.33	-
100	5.20	2.03	7.14	8.59	6.11	24.25	13.92	-	30.63	-	7.14	8.59	6.59	24.25	13.92	-	6.33	-
2-Row Hot Water + DX Interlaced																		
Unit Size	A	B	C	D	E	F	G	H	J	K	L	M	N	P	Q	R	S	T
060	-	-	7.45	9.00	6.11	18.25	13.88	15.19	19.63	4.00	7.45	9.00	6.59	18.25	13.88	15.19	7.33	4.00
080	-	-	7.50	9.04	6.11	22.25	13.91	15.35	23.63	4.00	7.50	9.04	6.59	22.25	13.91	15.35	7.33	4.00
100	5.20	2.03	6.92	9.25	6.11	24.25	12.35	15.48	27.61	2.00	6.92	9.25	9.33	24.25	12.35	15.48	7.33	2.00
1-Row Hot Water + DX Interlaced																		
Unit Size	A	B	C	D	E	F	G	H	J	K	L	M	N	P	Q	R	S	T
060	-	-	7.34	8.55	6.11	18.39	13.88	15.19	19.63	4.00	7.34	8.55	6.45	18.39	13.88	15.19	7.33	4.00
080	-	-	7.23	8.58	7.61	19.75	13.91	15.35	23.63	4.00	7.23	8.58	7.59	19.75	13.91	15.35	7.33	4.00
100	5.20	2.03	7.14	8.59	6.11	24.25	12.35	15.48	27.61	2.00	7.14	8.59	9.33	24.25	12.35	15.48	7.33	2.00
DX Single																		
Unit Size	A	B	C	D	E	F	G	H	J	K	L	M	N	P	Q	R	S	T
060	-	-	6.67	-	24.63	-	-	-	-	-	6.67	-	6.33	-	-	-	-	-
080	-	-	6.67	-	28.63	-	-	-	-	-	6.69	-	6.33	-	-	-	-	-
100	5.20	2.03	6.67	-	30.61	-	-	-	-	-	6.67	-	6.33	-	-	-	-	-
DX Interlaced																		
Unit Size	A	B	C	D	E	F	G	H	J	K	L	M	N	P	Q	R	S	T
060	-	-	6.67	7.98	19.63	4.00	-	-	-	-	6.67	7.98	7.33	4.00	-	-	-	-
080	-	-	6.66	8.10	23.63	4.00	-	-	-	-	6.66	8.10	7.33	4.00	-	-	-	-
100	5.20	2.03	5.11	8.23	27.61	2.00	-	-	-	-	5.11	8.23	9.33	2.00	-	-	-	-

NOTE: Dimensions shown in inches.

Table 70: Horizontal Steam Unit Dimensions (Unit Sizes 060-100) for Figure 48 on page 83

Steam + 8-Row Cold Water																		
Unit Size	A	B	C	D	E	F	G	H	J	K	L	M	N	P	Q	R	S	T
060	-	-	7.68	5.35	14.27	11.24	12.22	16.58	6.11	18.25	7.68	5.35	5.44	11.24	12.22	16.58	6.59	18.25
080	-	-	7.80	5.49	16.07	13.38	12.28	16.61	6.11	22.25	7.80	5.49	5.50	13.38	12.28	16.61	6.59	22.25
100	5.20	2.03	7.80	5.48	17.06	14.65	12.28	16.61	6.11	24.25	7.80	5.48	5.25	14.65	12.28	16.61	6.59	24.25
Steam + 6-Row Cold Water																		
Unit Size	A	B	C	D	E	F	G	H	J	K	L	M	N	P	Q	R	S	T
060	-	-	7.68	5.35	14.27	11.24	13.45	16.05	6.11	18.25	7.68	5.35	5.44	11.24	13.45	16.05	6.59	18.25
080	-	-	7.80	5.49	16.07	13.38	13.49	16.08	6.11	22.25	7.80	5.49	5.50	13.38	13.49	16.08	6.59	22.25
100	5.20	2.03	7.80	5.48	17.06	14.65	13.48	16.09	6.11	24.25	7.80	5.48	5.25	14.65	13.48	16.09	6.59	24.25
Steam + 4-Row Cold Water																		
Unit Size	A	B	C	D	E	F	G	H	J	K	L	M	N	P	Q	R	S	T
060	-	-	7.68	5.35	14.27	11.24	13.45	16.04	6.11	18.25	7.68	5.35	5.44	11.24	13.45	16.04	6.59	18.25
080	-	-	7.80	5.49	16.07	13.38	12.61	15.21	6.11	22.25	7.80	5.49	5.50	13.38	12.61	15.21	6.59	22.25
100	5.20	2.03	7.80	5.48	17.06	14.65	13.49	16.08	6.11	24.25	7.80	5.48	5.25	14.65	13.49	16.08	6.59	24.25
Steam + 2-Row Cold Water																		
Unit Size	A	B	C	D	E	F	G	H	J	K	L	M	N	P	Q	R	S	T
060	-	-	7.68	5.35	14.27	11.24	13.63	15.18	6.11	18.25	7.68	5.35	5.44	11.24	13.63	15.18	6.59	18.25
080	-	-	7.80	5.49	16.07	13.38	13.67	15.22	6.11	22.25	7.80	5.49	5.50	13.38	13.67	15.22	6.59	22.25
100	5.20	2.03	7.80	5.48	17.06	14.65	13.21	15.22	6.11	24.25	7.80	5.48	5.25	14.65	13.21	15.22	6.59	24.25
Steam + DX Single																		
Unit Size	A	B	C	D	E	F	G	H	J	K	L	M	N	P	Q	R	S	T
060	-	-	7.68	5.35	14.27	11.24	13.92	-	24.63	-	7.68	5.35	5.44	11.24	13.92	-	6.33	-
080	-	-	7.80	5.49	16.07	13.38	13.92	-	28.63	-	7.80	5.49	5.50	13.38	13.92	-	6.33	-
100	5.20	2.03	7.80	5.48	17.06	14.65	13.92	-	30.63	-	7.80	5.48	5.25	14.65	13.92	-	6.33	-
Steam + DX Interlaced																		
Unit Size	A	B	C	D	E	F	G	H	J	K	L	M	N	P	Q	R	S	T
060	-	-	7.68	5.35	14.27	11.24	13.92	15.23	19.63	4.00	7.68	5.35	5.44	11.24	13.92	15.23	7.33	4.00
080	-	-	7.80	5.49	16.07	13.38	13.91	15.35	23.63	4.00	7.80	5.49	5.50	13.38	13.91	15.35	7.33	4.00
100	5.20	2.03	7.80	5.48	17.06	14.65	12.35	15.48	27.61	2.00	7.80	5.48	5.25	14.65	12.35	15.48	7.33	2.00

NOTE: Dimensions shown in inches.

Figure 49: Vertical Unit Dimensions - Two Fans (Unit Sizes 060-100)

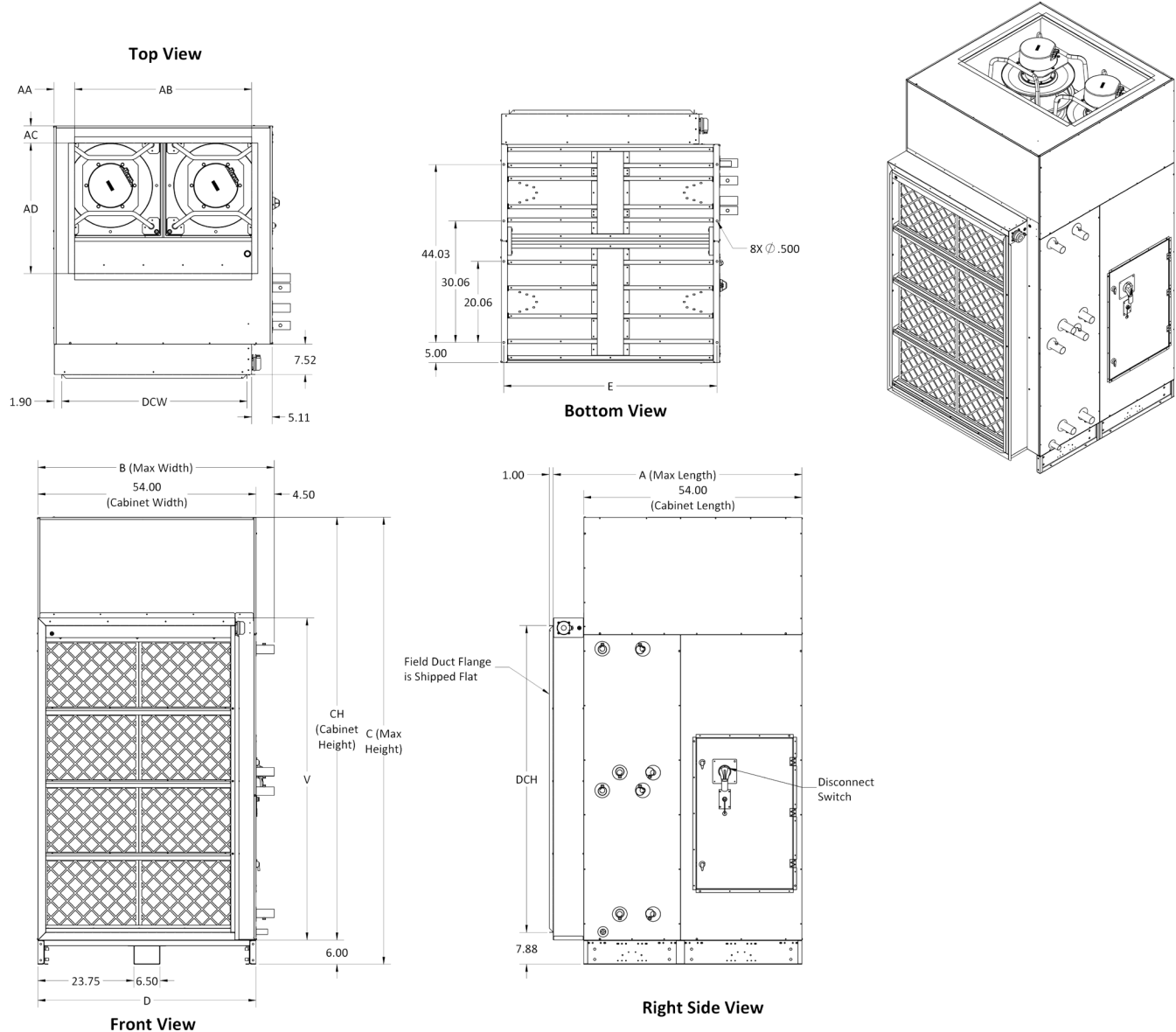

NOTE 1: Dimensions shown in inches.

NOTE 2: Right hand cabinet shown, left hand similar but opposite.

Table 71: Vertical Unit Dimensions - Two Fans (Unit Sizes 060-100)

Unit Size	A Max Length	B Max Width	C Max Height	D	E	U	V	DCH	DCW	CH
060	61.57	58.50	85.54	54.00	52.76	4.50	51.19	47.42	45.84	79.49
080	61.57	58.50	96.61	54.00	52.76	4.50	65.68	61.91	45.84	90.56
100	61.57	58.50	110.61	54.00	52.76	4.50	79.68	75.91	45.84	104.56

NOTE: Dimensions shown in inches.

Table 72: Vertical Unit Top Duct Dimensions - Two Fan (Unit Sizes 060-100)

Dimension	060	080	100
AA	6.23	5.11	5.11
AB	41.53	43.78	43.78
AC	5.10	4.27	4.27
AD	18.78	23.78	32.28

NOTE: Dimensions shown in inches.

Vertical Unit Dimensions - One Fan (Unit Sizes 060-100)

TOP DUCT (1 FAN)

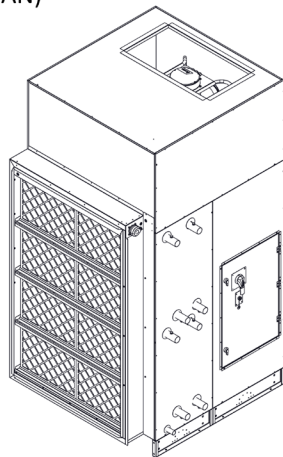
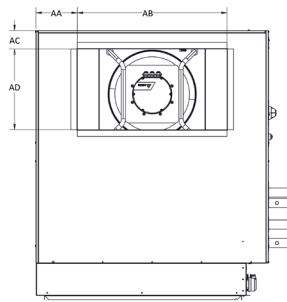

END DUCT (1 FAN)

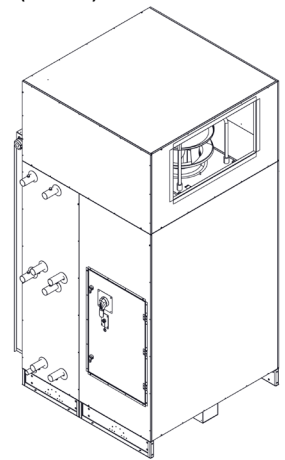
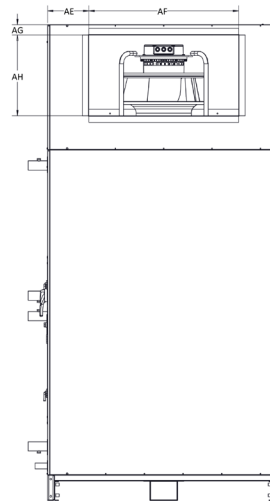

**LEFT DUCT - RH UNIT
RIGHT DUCT - LH UNIT**

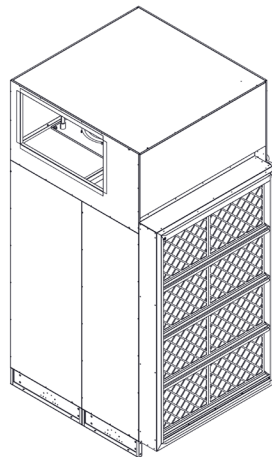
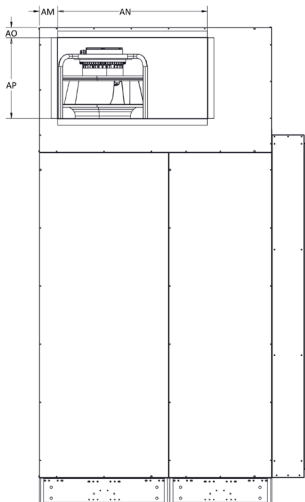

NOTE:
LEFT DUCT ONLY APPLY FOR RH UNITS
RIGHT DUCT ONLY APPLY FOR LH UNITS

DIMENSIONS WILL BE THE SAME FOR BOTH DUCTS

NOTE: Dimensions shown in inches.

Table 73: Vertical Unit Dimensions - One Fan (Unit Sizes 060-100)

Dimension	060	080	100
AA	13.61	12.11	9.61
AB	26.78	29.78	34.78
AC	5.10	4.27	4.27
AD	14.78	17.78	18.78
AE	13.61	12.11	9.61
AF	26.78	29.78	34.78
AG	4.38	2.88	2.38
AH	14.78	17.78	18.78

Dimension	060	080	100
AM	5.10	4.27	4.27
AN	26.78	29.78	34.78
AO	2.36	2.36	2.36
AP	14.78	17.78	18.78

NOTE: Dimensions shown in inches.

Figure 50: Vertical Hydronic Coil Unit Dimensions (Unit Sizes 060-100)

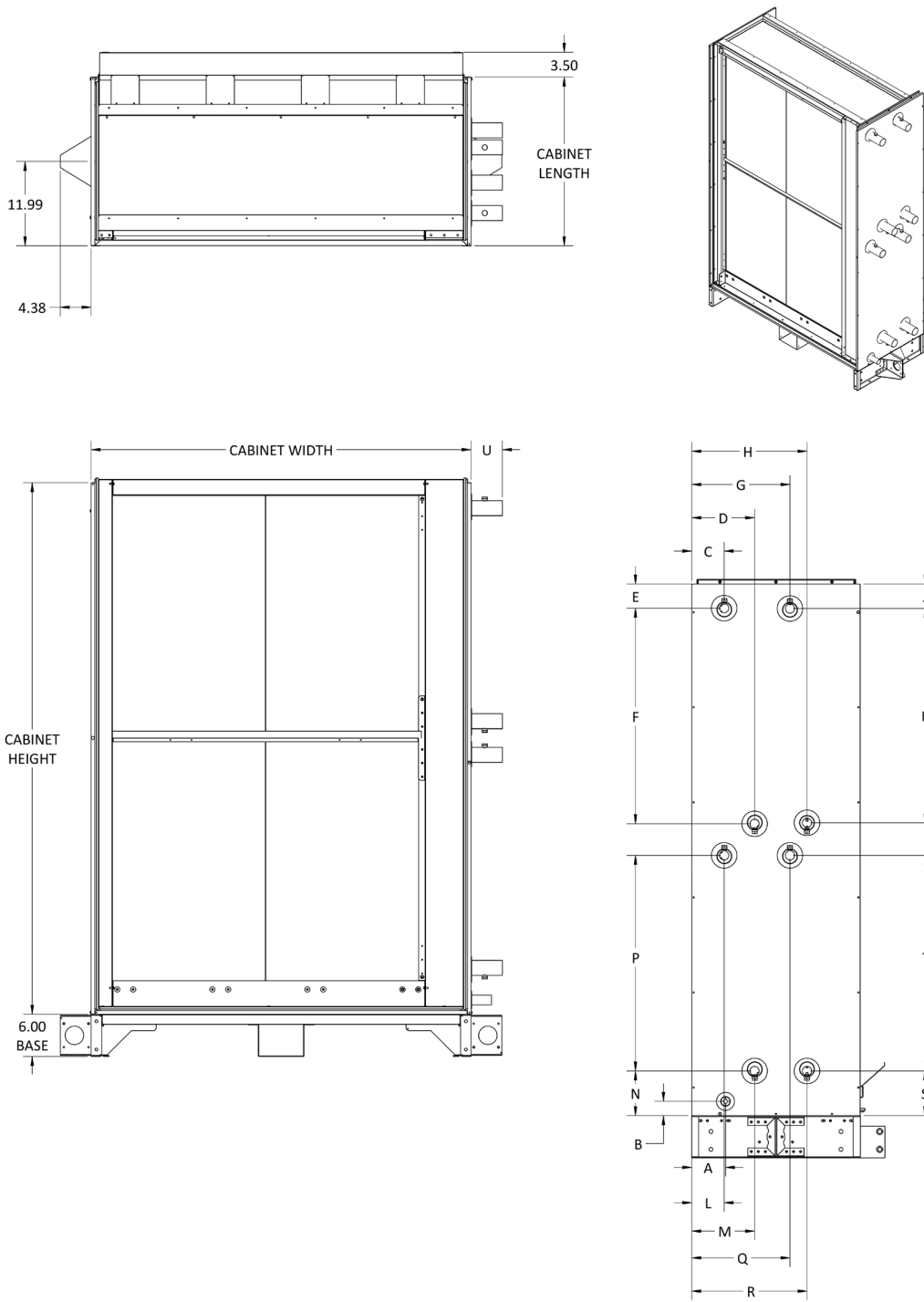

NOTE: Dimensions shown in inches.

Table 74: Vertical Unit Coil Dimensions (Unit Sizes 060-100)

Unit Size	Cabinet Length	Maximum Length*	Width	Height	U
060	23.97	27.47	54.00	50.44	4.50
080	23.97	27.47	54.00	61.50	4.50
100	23.97	27.47	54.00	75.50	4.50

NOTE 1: *Max coil section length includes portion of the drain pan which extends into the supply fan section. The coil and supply fan sections together make up the base unit cabinet.

NOTE 2: Dimensions shown in inches.
DAIKIN APPLIED

Table 75: Vertical Hydronic Coil Unit Dimensions (Unit Sizes 060-100) for Figure 50 on page 90

2-Row																		
Unit Size	A	B	C	D	E	F	G	H	J	K	L	M	N	P	Q	R	S	T
060	4.76	2.03	5.84	8.42	6.30	16.75	-	-	-	-	5.84	8.42	6.34	16.75	-	-	-	-
080	4.76	2.03	5.84	8.42	4.36	22.75	-	-	-	-	5.84	8.42	6.34	22.75	-	-	-	-
100	4.76	2.03	5.84	8.42	3.36	30.75	-	-	-	-	5.84	8.42	6.34	30.75	-	-	-	-
4-Row																		
Unit Size	A	B	C	D	E	F (Std/Low)	G	H	J	K	L (Std/Low)	M	N (Std/Low)	P (Std/Low)	Q	R	S	T
060	4.76	2.03	5.83	8.43	6.30	16.75	-	-	-	-	5.83	8.43	6.34	16.75	-	-	-	-
080	4.76	2.03	5.83	8.43	3.36	23.75	-	-	-	-	5.83	8.43	6.34	23.75	-	-	-	-
						22.75							7.34	22.75				
100	4.76	2.03	5.83	8.43	3.36	30.75	-	-	-	-	5.83	8.43	6.34	30.75	-	-	-	-
6-Row																		
Unit Size	A	B	C (Std/Low)	D (Std/Low)	E	F (Std/Low)	G	H	J	K	L (Std/Low)	M (Std/Low)	N (Std/Low)	P (Std/Low)	Q	R	S	T
060	4.76	2.03	5.94	8.32	6.30	16.75	-	-	-	-	5.94	8.32	6.34	16.75	-	-	-	-
			4.97	9.30		15.75					4.97	9.30	7.34	15.75				
080	4.76	2.03	5.83	8.43	3.36	23.75	-	-	-	-	5.83	8.43	6.34	23.75	-	-	-	-
100	4.76	2.03	5.83	8.44	3.36	30.75	-	-	-	-	5.83	8.44	6.34	30.75	-	-	-	-
			4.96	9.30							4.96	9.30						
8-Row																		
Unit Size	A	B	C	D	E	F	G	H	J	K	L	M	N	P	Q	R	S	T
060	4.76	2.03	4.62	8.95	6.30	16.75	-	-	-	-	4.62	8.95	6.34	16.75	-	-	-	-
080	4.76	2.03	4.62	8.95	3.36	23.75	-	-	-	-	4.62	8.95	6.34	23.75	-	-	-	-
100	4.76	2.03	4.62	8.95	3.36	30.75	-	-	-	-	4.62	8.95	6.34	30.75	-	-	-	-
2-Row Cold Water + 1-Row Hot Water																		
Unit Size	A	B	C	D	E	F	G	H	J	K	L	M	N	P	Q	R	S	T
060	4.76	2.03	5.84	8.42	6.30	16.75	13.68	16.48	6.80	16.25	5.84	8.42	6.34	16.75	13.68	16.48	6.34	16.25
080	4.76	2.03	5.84	8.42	4.36	22.75	13.68	16.37	4.86	22.25	5.84	8.42	6.34	23.75	13.68	16.37	6.34	22.25
100	4.76	2.03	5.84	8.42	3.36	30.75	13.68	16.48	3.86	30.25	5.84	8.42	6.34	30.75	13.68	16.48	6.34	30.25
2-Row Cold Water + 2-Row Hot Water																		
Unit Size	A	B	C	D	E	F	G (Std/Low)	H	J (Std/Low)	K (Std/Low)	L	M	N	P	Q (Std/Low)	R	S	T (Std/Low)
060	4.76	2.03	5.84	8.42	6.30	16.75	13.95	16.37	6.30	16.75	5.84	8.42	6.34	16.75	13.95	16.37	6.34	16.75
							13.68								13.68			
080	4.76	2.03	5.84	8.42	4.36	22.75	13.95	16.37	3.36	23.75	5.84	8.42	6.34	22.75	13.95	16.37	6.34	23.75
							13.68		4.36	22.75					13.68			22.75
100	4.76	2.03	5.84	8.42	3.36	30.75	13.95	16.37	3.36	30.75	5.84	8.42	6.34	30.75	13.95	16.37	6.34	30.75
							13.68		4.74	29.38					13.68			29.38

4-Row Cold Water + 1-Row Hot Water																		
Unit Size	A	B	C	D	E	F (Std/Low)	G	H	J	K	L	M	N (Std/Low)	P (Std/Low)	Q	R	S	T
060	4.76	2.03	5.83	8.43	6.30	16.75	13.68	16.48	6.80	16.25	5.83	8.43	6.34	16.75	13.68	16.48	6.34	16.25
080	4.76	2.03	5.83	8.43	3.36	22.75	13.68	16.37	4.86	22.25	5.83	8.43	7.34	22.75	13.68	16.37	6.34	22.25
						23.75							6.34	23.75				
100	4.76	2.03	5.83	8.43	3.36	30.75	13.68	16.48	3.86	30.25	5.83	8.42	6.34	30.75	13.68	16.48	6.34	30.25
4-Row Cold Water + 2-Row Hot Water																		
Unit Size	A	B	C	D	E	F (Std/Low)	G (Std/Low)	H	J (Std/Low)	K (Std/Low)	L	M	N (Std/Low)	P (Std/Low)	Q (Std/Low)	R	S	T (Std/Low)
060	4.76	2.03	5.83	8.43	6.30	16.75	13.95	16.37	6.3	16.75	5.83	8.43	6.34	16.75	13.95	16.37	6.34	16.75
							13.68								13.68			
080	4.76	2.03	5.83	8.43	3.36	23.75	13.95	16.37	3.36	23.75	5.83	8.43	6.34	23.75	13.95	16.37	6.34	23.75
						22.75	13.68		4.36	22.75			7.34	22.75	13.68			
100	4.76	2.03	5.83	8.43	3.36	30.75	13.95	16.37	3.36	30.75	5.83	8.43	6.34	30.75	13.95	16.37	6.34	30.75
							13.68		4.74	29.38					13.68			
6-Row Cold Water + 2-Row Hot Water																		
Unit Size	A	B	C (Std/Low)	D (Std/Low)	E	F (Std/Low)	G (Std/Low)	H	J (Std/Low)	K (Std/Low)	L (Std/Low)	M (Std/Low)	N (Std/Low)	P (Std/Low)	Q (Std/Low)	R	S	T (Std/Low)
060	4.76	2.03	5.94	8.32	6.30	16.75	13.95	16.37	6.30	16.75	5.94	8.32	6.34	16.75	13.95	16.37	6.34	16.75
			4.97	9.30		15.75	13.68				4.97	9.30			7.34			
080	4.76	2.03	5.83	8.43	3.36	23.75	13.95	16.37	3.36	23.75	5.83	8.43	6.34	23.75	13.95	16.37	6.34	23.75
							13.68		4.36	22.75					13.68			
100	4.76	2.03	5.83	8.44	3.36	30.75	13.95	16.37	3.36	30.75	5.83	8.44	6.34	30.75	13.95	16.37	6.34	30.75
			4.96	9.30			13.68		4.74	29.38					4.96			
6-Row Cold Water + 1-Row Hot Water																		
Unit Size	A	B	C (Std/Low)	D (Std/Low)	E	F (Std/Low)	G	H	J	K	L (Std/Low)	M (Std/Low)	N (Std/Low)	P (Std/Low)	Q	R	S	T
060	4.76	2.03	4.97	9.30	6.30	15.75	13.68	16.48	6.80	16.25	4.97	9.30	7.34	15.75	13.68	16.48	6.34	16.25
			5.94	8.32		16.75					5.94	8.32		6.34				
080	4.76	2.03	5.83	8.43	3.36	23.75	13.68	16.37	4.86	22.25	5.83	8.43	6.34	23.75	13.68	16.37	6.34	22.25
100	4.76	2.03	5.83	8.44	3.36	30.75	13.68	16.48	3.86	30.25	5.83	8.44	6.34	30.75	13.68	16.48	6.34	30.25
			4.96	9.30							4.96	9.30						
8-Row Cold Water + 1-Row Hot Water																		
Unit Size	A	B	C	D	E	F	G	H	J	K	L	M	N	P	Q	R	S	T
060	4.76	2.03	4.62	8.95	6.30	16.75	13.68	16.48	6.80	16.25	4.62	8.95	6.34	16.75	13.68	16.48	6.34	16.25
080	4.76	2.03	4.62	8.95	3.36	23.75	13.68	16.37	4.86	22.25	4.62	8.95	6.34	23.75	13.68	16.37	6.34	22.25
100	4.76	2.03	4.62	8.95	3.36	30.75	13.68	16.48	3.86	30.25	4.62	8.95	6.34	30.75	13.68	16.48	6.34	30.25
8-Row Cold Water + 2-Row Hot Water																		
Unit Size	A	B	C	D	E	F	G (Std/Low)	H	J (Std/Low)	K (Std/Low)	L	M	N	P	Q (Std/Low)	R	S	T (Std/Low)
060	4.76	2.03	4.62	8.95	6.30	16.75	13.95	16.37	6.30	16.75	4.62	8.95	6.34	16.75	13.95	16.37	6.34	16.75
							13.68								13.68			
080	4.76	2.03	4.62	8.95	3.36	23.75	13.95	16.37	3.36	23.75	4.62	8.95	6.34	23.75	13.95	16.37	6.34	23.75
							13.68		4.36	22.75					13.68			
100	4.76	2.03	4.62	8.95	3.36	30.75	13.95	16.37	4.74	29.38	4.62	8.95	6.34	30.75	13.95	16.37	6.34	29.38
							13.68		13.68									

1-Row Hot Water + 2-Row Cold Water																		
Unit Size	A	B	C	D	E	F	G	H	J	K	L	M	N	P	Q	R	S	T
060	4.76	2.03	5.43	8.23	6.80	16.25	13.09	15.67	6.30	16.75	5.43	8.23	6.34	16.25	13.09	15.67	6.34	16.75
080	4.76	2.03	5.43	8.12	4.86	22.25	13.09	15.67	4.36	22.75	5.43	8.12	6.34	22.25	13.09	15.67	6.34	22.75
100	4.76	2.03	5.43	8.23	3.86	30.25	13.09	15.67	3.36	30.75	5.43	8.23	6.34	30.25	13.09	15.67	6.34	30.75
1-Row Hot Water + 4-Row Cold Water																		
Unit Size	A	B	C	D	E	F	G	H	J	K	L	M	N	P	Q	R	S (Std/Low)	T (Std/Low)
060	4.76	2.03	5.43	8.23	6.80	16.25	13.08	15.68	6.30	16.75	5.43	8.23	6.34	16.25	13.08	15.68	6.34	16.75
080	4.76	2.03	5.43	8.12	4.86	22.25	13.08	15.68	3.36	23.75	5.43	8.12	6.34	22.25	13.08	15.68	6.34	23.75
100	4.76	2.03	5.43	8.23	3.86	30.25	13.08	15.68	3.36	30.75	5.43	8.23	6.34	30.25	13.08	15.68	6.34	30.75
																	6.34	23.75
																	7.34	22.75
																	6.34	30.75
1-Row Hot Water + 6-Row Cold Water																		
Unit Size	A	B	C	D	E	F	G (Std/Low)	H (Std/Low)	J	K	L	M	N	P	Q (Std/Low)	R (Std/Low)	S (Std/Low)	T (Std/Low)
060	4.76	2.03	5.43	8.23	6.80	16.25	13.19	15.57	6.30	16.75	5.43	8.23	6.34	16.25	13.19	15.57	6.34	16.75
							12.22	16.55							12.22	16.55	7.34	15.75
080	4.76	2.03	5.43	8.12	4.86	22.25	13.08	15.68	3.36	23.75	5.43	8.12	6.34	22.25	13.08	15.68	6.34	23.75
100	4.76	2.03	5.43	8.23	3.86	30.25	13.08	15.68	3.36	30.75	5.43	8.23	6.34	30.25	13.08	15.68	6.34	30.75
							12.21	16.55							12.21	16.55		
1-Row Hot Water + 8-Row Cold Water																		
Unit Size	A	B	C	D	E	F	G	H	J	K	L	M	N	P	Q	R	S	T
060	4.76	2.03	5.43	8.23	6.80	16.25	11.87	16.20	6.30	16.75	5.43	8.23	6.34	16.25	11.87	16.20	6.34	16.75
080	4.76	2.03	5.43	8.12	4.86	22.25	11.87	16.20	3.36	23.75	5.43	8.12	6.34	22.25	11.87	16.20	6.34	23.75
100	4.76	2.03	5.43	8.23	3.86	30.25	11.87	16.20	3.36	30.75	5.43	8.23	6.34	30.25	11.87	16.20	6.34	30.75
2-Row Hot Water + 2-Row Cold Water																		
Unit Size	A	B	C (Std/Low)	D	E (Std/Low)	F (Std/Low)	G	H	J	K	L (Std/Low)	M	N	P (Std/Low)	Q	R	S	T
060	4.76	2.03	5.70	8.12	6.30	16.75	13.09	15.67	6.30	16.75	5.70	8.12	6.34	16.75	13.09	15.67	6.34	16.75
			5.43								5.43							
080	4.76	2.03	5.70	8.12	3.36	23.75	13.09	15.67	4.36	22.75	5.70	8.12	6.34	23.75	13.09	15.67	6.34	22.75
			5.43		4.36	22.75					5.43			22.75				
100	4.76	2.03	5.70	8.12	3.36	30.75	13.09	15.67	3.36	30.75	5.70	8.12	6.34	30.75	13.09	15.67	6.34	30.75
			5.43		4.74	29.38					5.43			29.38				
2-Row Hot Water + 4-Row Cold Water																		
Unit Size	A	B	C (Std/Low)	D	E (Std/Low)	F (Std/Low)	G	H	J	K (Std/Low)	L (Std/Low)	M	N	P (Std/Low)	Q	R	S (Std/Low)	T (Std/Low)
060	4.76	2.03	5.70	8.12	6.30	16.75	13.08	15.68	6.30	16.75	5.70	8.12	6.34	16.75	13.08	15.68	6.34	16.75
			5.43								5.43							
080	4.76	2.03	5.70	8.12	3.36	23.75	13.08	15.68	3.36	23.75	5.70	8.12	6.34	23.75	13.08	15.68	6.34	23.75
			5.43		4.36	22.75				22.75	5.43			22.75			7.34	22.75
100	4.76	2.03	5.70	8.12	3.36	30.75	13.08	15.68	3.36	30.75	5.70	8.12	6.34	30.75	13.08	15.68	6.34	30.75
			5.43		4.74	29.38					5.43			29.38				

2-Row Hot Water + 6-Row Cold Water																		
Unit Size	A	B	C (Std/ Low)	D	E (Std/ Low)	F (Std/ Low)	G (Std/ Low)	H (Std/ Low)	J	K (Std/ Low)	L (Std/ Low)	M	N	P (Std/ Low)	Q (Std/ Low)	R (Std/ Low)	S (Std/ Low)	T (Std/ Low)
060	4.76	2.03	5.70	8.12	6.30	16.75	13.19	15.57	6.30	16.75	5.70	8.12	6.34	16.75	13.19	15.57	6.34	16.75
			5.43				12.22	16.55		15.75	5.43				12.22	16.55	7.34	15.75
080	4.76	2.03	5.70	8.12	3.36	23.75	13.08	15.68	3.36	23.75	5.70	8.12	6.34	23.75	13.08	15.68	6.34	23.75
			5.43		4.36	22.75					5.43			22.75				
100	4.76	2.03	5.70	8.12	3.36	30.75	13.08	15.68	3.36	30.75	5.70	8.12	6.34	30.75	13.08	15.68	6.34	30.75
			5.43		4.74	29.38					12.21			16.55				

2-Row Hot Water + 8-Row Cold Water																		
Unit Size	A	B	C (Std/ Low)	D	E (Std/ Low)	F (Std/ Low)	G	H	J	K	L (Std/ Low)	M	N	P (Std/ Low)	Q	R	S	T
060	4.76	2.03	5.70	8.12	6.30	16.75	11.87	16.20	6.30	16.75	5.70	8.12	6.34	16.75	11.87	16.20	6.34	16.75
			5.43								5.43							
080	4.76	2.03	5.70	8.12	3.36	23.75	11.87	16.20	3.36	23.75	5.70	8.12	6.34	23.75	11.87	16.20	6.34	23.75
			5.43		4.36	22.75					5.43			22.75				
100	4.76	2.03	5.70	8.12	3.36	30.75	11.87	16.20	3.36	30.75	5.70	8.12	6.34	30.75	11.87	16.20	6.34	30.75
			5.43		4.74	29.38					5.43			29.38				

LEGEND	
Std	Standard Circuiting Flow
Low	Low Circuiting Flow

NOTE: Dimensions shown in inches.

Figure 51: Vertical Unit DX Coil Dimensions (Unit Sizes 060-100)

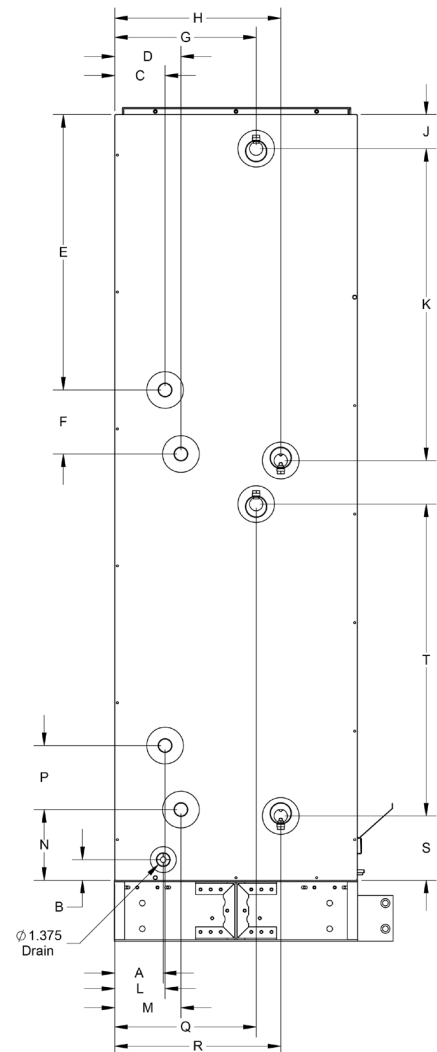
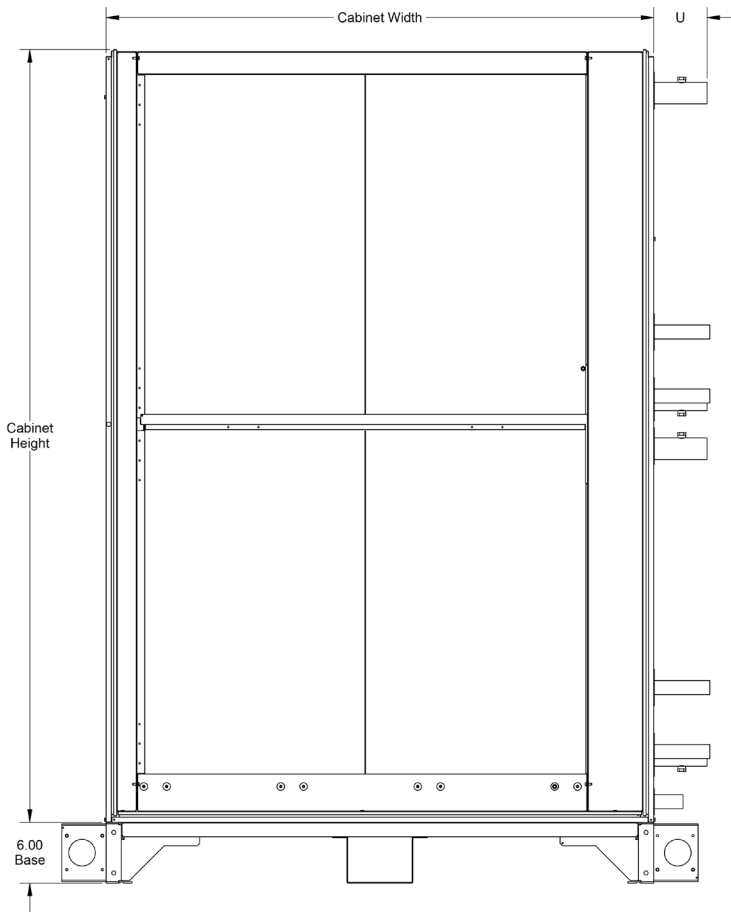
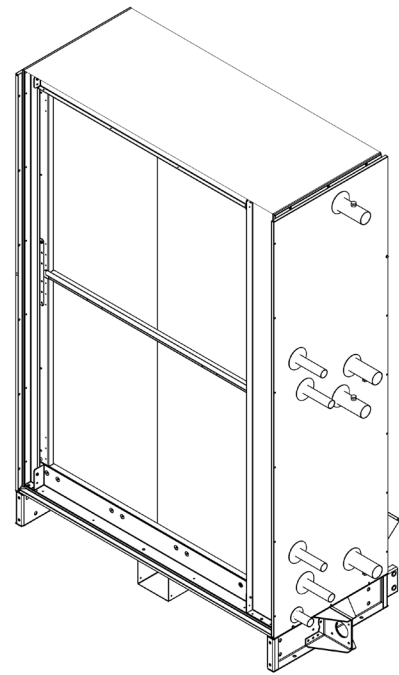
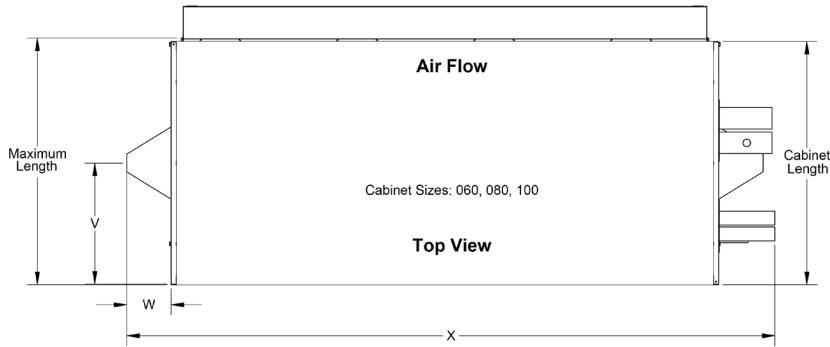

Table 76: Vertical DX Coil Unit Dimensions (Unit Sizes 060-100) for Figure 51 on page 95

3-Row DX + 2-Row HW																		
Unit Size	A	B	C (Std/ Low)	D (Std/ Low)	E (Std/ Low)	F (Std/ Low)	G (Std/ Low)	H	J (Std/ Low)	K (Std/ Low)	L (Std/ Low)	M (Std/ Low)	N (Std/ Low)	P (Std/ Low)	Q (Std/ Low)	R	S	T (Std/ Low)
060	4.760	2.030	6.264	7.5765	20.672	2.818	13.947	16.371	6.302	16.750	6.264	7.5765	5.903	2.818	13.947	16.371	6.341	16.750
				-	22.74	-	13.6835					-	6.653	-	13.6835			
080	4.760	2.030	6.38	7.8175	24.607	4.000	13.947	16.371	3.362	23.750	6.264	7.8175	7.846	4.000	13.947	16.371	6.341	23.750
			6.264	-	26.145	-	13.6835					4.362	22.750	-	7.308			-
100	4.760	2.030	4.701	7.8265	30.115	3.3545	13.947	16.371	3.362	30.750	4.701	7.8265	6.971	3.3545	13.947	16.371	6.341	30.750
			6.264	-	34.114	-	13.6835					4.737	29.375	6.264	-			6.326
3-Row DX + 1-Row HW																		
Unit Size	A	B	C (Std/ Low)	D (Std/ Low)	E (Std/ Low)	F (Std/ Low)	G	H	J	K	L (Std/ Low)	M (Std/ Low)	N (Std/ Low)	P (Std/ Low)	Q	R	S	T
060	4.760	2.030	6.264	7.5765	20.658	2.818	13.683	16.482	6.802	16.250	6.264	7.5765	5.903	2.818	13.683	16.482	6.341	16.250
				-	22.740	-						-	-	-				
080	4.760	2.030	6.264	7.7015	16.918	4.000	13.684	16.371	4.862	22.250	6.264	7.7015	12.521	4.000	13.684	16.371	6.341	22.250
				-	26.131	-						-	-	-				
100	4.760	2.030	4.701	7.8265	30.114	3.354	13.683	16.483	3.862	30.250	4.701	7.8265	6.971	3.3545	13.683	16.482	6.341	30.250
			6.264	-	34.127	-						-	-	-				
3-Row DX																		
Unit Size	A	B	C (Std/ Low)	D (Std/ Low)	E (Std/ Low)	F (Std/ Low)	G	H	J	K	L (Std/ Low)	M (Std/ Low)	N (Std/ Low)	P (Std/ Low)	Q	R	S	T
060	4.760	2.030	6.264	7.5765	20.708	2.818	-	-	-	-	6.264	7.5765	5.903	2.818	-	-	-	-
				-	22.776	-						-	-	-				
080	4.760	2.030	6.264	7.7015	24.593	4.000	-	-	-	-	6.264	7.7015	7.846	4.000	-	-	-	-
				-	26.131	-						-	-	-				
100	4.760	2.030	4.701	7.8265	30.127	3.354	-	-	-	-	4.701	7.8265	6.971	3.354	-	-	-	-
			6.264	-	34.127	-						-	-	-				
2-Row HW + 3-Row DX																		
Unit Size	A	B	C (Std/ Low)	D	E (Std/ Low)	F (Std/ Low)	G (Std/ Low)	H (Std/ Low)	J (Std/ Low)	K (Std/ Low)	L (Std/ Low)	M	N	P (Std/ Low)	Q (Std/ Low)	R (Std/ Low)	S (Std/ Low)	T (Std/ Low)
060	4.760	2.030	5.697	8.121	6.303	16.750	13.514	14.826	20.658	2.818	5.697	8.121	6.341	16.750	13.514	14.826	5.903	2.818
			5.433					-	22.740	-	5.433							
080	4.760	2.030	5.697	8.121	3.362	23.750	13.514	14.951	21.593	4.000	5.697	8.121	6.341	23.750	13.514	14.951	7.846	4.000
			5.433		4.362	22.750		-	26.131	-	5.433			22.750				
100	4.760	2.030	5.697	8.121	3.362	30.750	11.951	15.076	30.114	3.3545	5.697	8.121	6.341	30.750	11.951	15.076	6.971	3.354
			5.432		4.737	29.375	13.514	-	34.514	-	5.432			29.375				
1-Row HW + 3-Row DX																		
Unit Size	A	B	C	D	E	F	G (Std/ Low)	H (Std/ Low)	J (Std/ Low)	K (Std/ Low)	L	M	N	P	Q (Std/ Low)	R (Std/ Low)	S (Std/ Low)	T (Std/ Low)
060	4.760	2.030	5.433	8.232	6.802	16.250	13.514	14.826	20.658	2.818	5.433	8.232	6.802	16.250	13.514	14.826	5.903	2.818
								-	22.740	-								
080	4.760	2.030	5.433	8.121	4.862	22.250	13.514	14.951	21.593	4.000	5.433	8.120	6.341	22.250	13.514	14.951	7.846	4.000
								-	26.131	-								
100	4.760	2.030	5.433	8.232	3.862	30.250	11.951	15.076	30.127	3.3545	5.432	8.232	6.341	30.250	11.951	15.076	6.971	3.354
							13.514	-	34.127	-					13.514			

6-Row DX + 2-Row HW																		
Unit Size	A	B	C	D	E	F	G (Std/Low)	H	J (Std/Low)	K (Std/Low)	L	M	N	P	Q (Std/Low)	R	S	T (Std/Low)
060	4.760	2.030	4.965	6.402	20.110	3.438	13.947	16.371	6.303	16.750	4.965	6.402	5.847	3.438	13.947	16.371	6.341	16.750
							13.6835								13.6835			
080	4.760	2.030	4.965	6.527	23.170	4.313	13.947	16.371	3.363	23.750	4.965	6.527	5.972	4.313	13.947	16.371	6.341	23.750
							13.6835			22.750					13.6835			22.750
100	4.760	2.030	4.965	6.527	27.158	6.313	13.947	16.371	3.362	30.750	4.965	6.527	6.972	6.313	13.947	16.371	6.341	30.750
							13.6835		4.362	29.375					13.6835			29.375
6-Row DX + 1-Row HW																		
Unit Size	A	B	C	D	E	F	G	H	J	K	L	M	N	P	Q	R	S	T
060	4.760	2.030	4.965	6.402	20.096	3.438	13.684	16.483	6.803	16.250	4.965	6.402	5.847	3.438	13.684	16.483	6.341	16.250
080	4.760	2.030	4.965	6.527	23.156	4.313	13.685	16.372	4.863	22.250	4.965	6.527	5.972	4.313	13.685	16.372	6.341	22.250
100	4.760	2.030	4.965	6.527	27.157	6.313	13.683	16.483	3.863	30.250	4.965	6.527	6.972	6.313	13.683	16.483	6.341	30.250
2-Row HW + 6-Row DX																		
Unit Size	A	B	C (Std/Low)	D	E (Std/Low)	F (Std/Low)	G	H	J	K	L (Std/Low)	M	N	P (Std/Low)	Q	R	S	T
060	4.760	2.030	5.697	8.121	6.303	16.750	12.215	13.652	20.096	3.438	5.697	8.121	6.341	16.750	12.215	13.652	5.847	3.438
			5.433								5.433							
080	4.760	2.030	5.697	8.121	3.362	23.750	12.215	13.774	23.156	4.313	5.697	8.121	6.341	23.750	12.215	13.777	5.972	4.313
			5.433		4.362	22.750					5.433			22.750				
100	4.760	2.030	5.697	8.121	3.362	30.750	12.215	13.777	27.157	6.313	5.697	8.121	6.341	30.750	12.215	13.777	6.972	6.313
			5.433		4.737	29.375					5.433			29.375				
1-Row HW + 6-Row DX																		
Unit Size	A	B	C	D	E	F	G	H	J	K	L	M	N	P	Q	R	S	T
060	4.760	2.030	5.434	8.233	6.803	16.250	12.215	13.652	20.096	3.438	5.434	8.233	6.341	16.250	12.215	13.652	5.847	3.438
080	4.760	2.030	5.434	8.121	4.863	22.250	12.215	13.777	23.156	4.313	5.434	8.121	6.341	22.250	12.215	13.777	5.972	4.313
100	4.760	2.030	5.433	8.233	3.863	30.250	12.215	13.777	27.170	6.313	5.433	8.233	6.341	30.250	12.215	13.777	6.972	6.313
6-Row DX																		
Unit Size	A	B	C	D	E	F	G	H	J	K	L	M	N	P	Q	R	S	T
060	4.760	2.030	4.964	6.402	20.145	3.437	-	-	-	-	4.965	6.402	5.847	3.438	-	-	-	-
080	4.760	2.030	4.965	6.527	23.156	4.313	-	-	-	-	4.965	6.527	5.972	4.313	-	-	-	-
100	4.760	2.030	4.965	6.527	27.170	6.313	-	-	-	-	4.965	6.527	6.972	6.313	-	-	-	-

LEGEND	
Std	Standard Circuiting Flow
Low	Low Circuiting Flow

NOTE: Dimensions shown in inches.

Figure 52: Horizontal Mixing Box Dimensions (Unit Sizes 060-100)

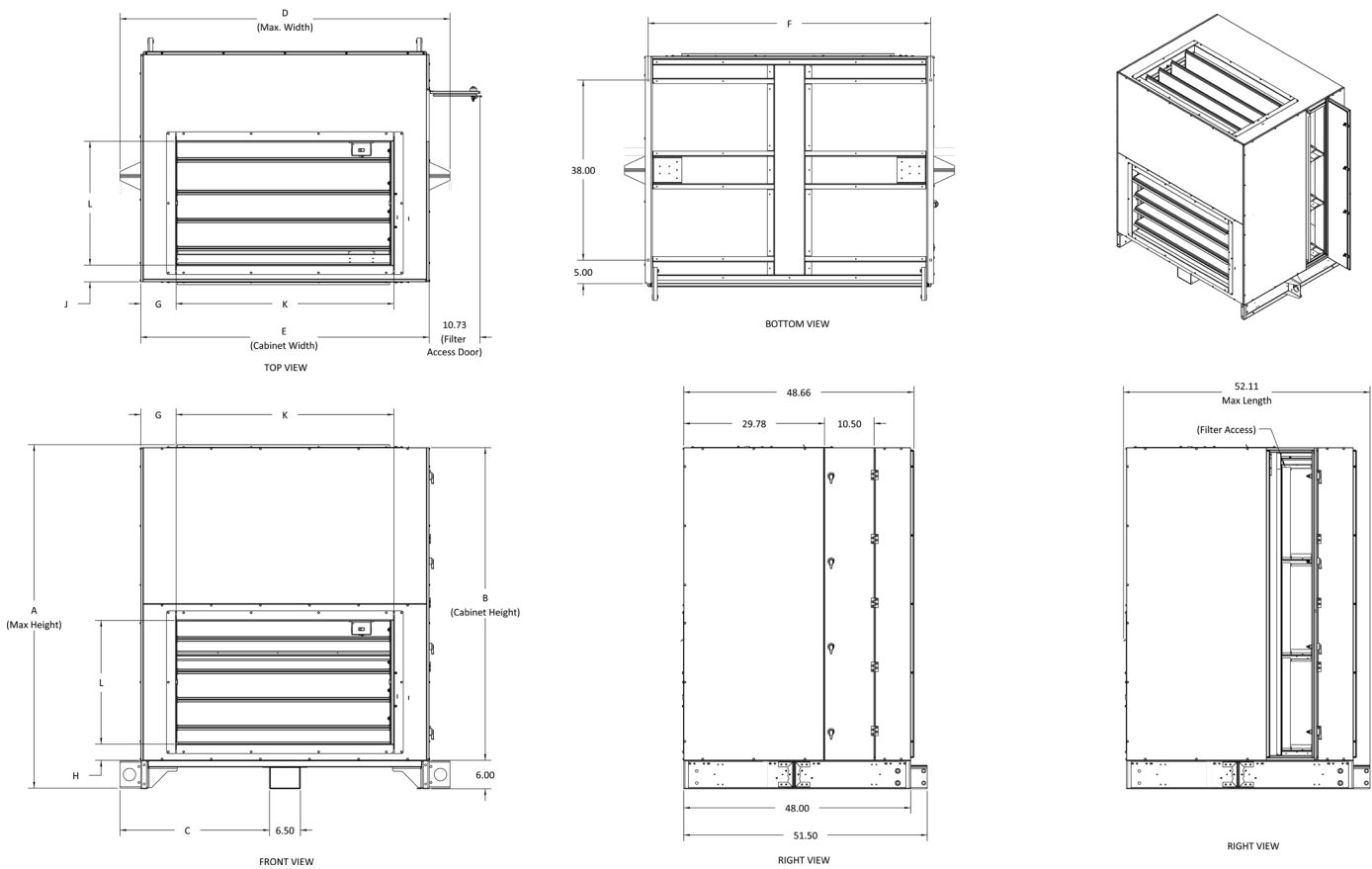

NOTE: Dimensions shown in inches.

Table 77: Mixing Box Dimension Letter Reference

Dimension	060	080	100
A	60.00	68.00	72.00
B	54.00	62.00	66.00
C	28.13	28.13	31.63
D	62.75	62.75	69.75
E	54.00	54.00	61.00
F	52.76	52.76	59.76
G	10.19	4.94	7.49
H	2.45	2.45	3.43
J	3.16	3.16	3.53
K	33.63	44.13	46.03
L	22.07	22.07	26.11

NOTE: Dimensions shown in inches.

Figure 53: Vertical Mixing Box Dimensions (Unit Sizes 060-100)

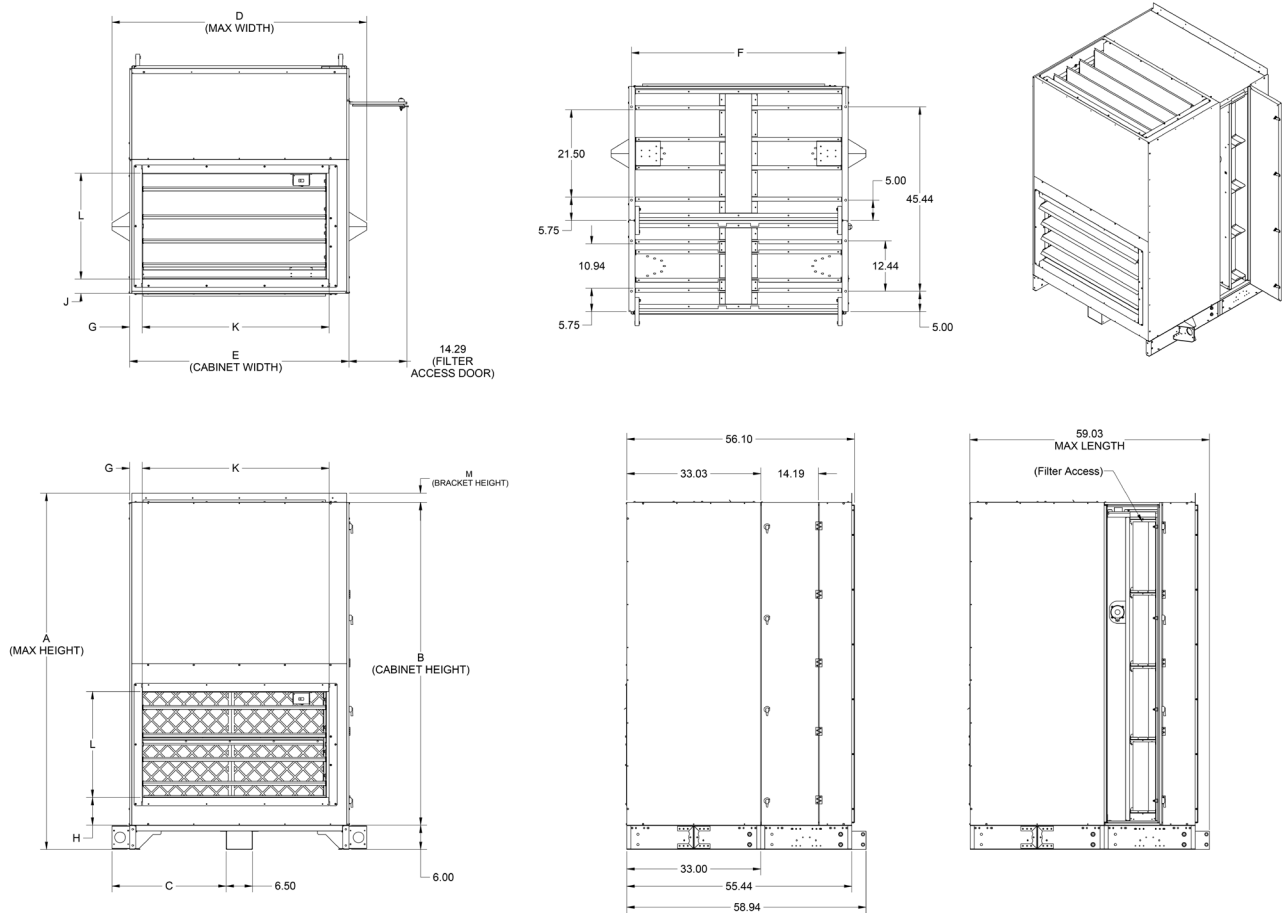

NOTE: Dimensions shown in inches.

Table 78: Mixing Box Dimension Letter Reference

Dimension	060	080	100
A	85.50	87.76	87.76
B	79.50	79.50	79.50
C	28.12	28.12	28.12
D	62.75	62.75	62.75
E	54.00	54.00	54.00
F	52.76	52.76	52.76
G	10.18	4.93	3.07
H	8.83	8.83	6.81
J	5.72	3.07	3.54
K	33.63	44.13	46.03
L	22.07	22.07	26.11
M	-	2.26	2.26

NOTE: Dimensions shown in inches.

Figure 54: Discharge Plenum Without Filter (Unit Sizes 060-100)

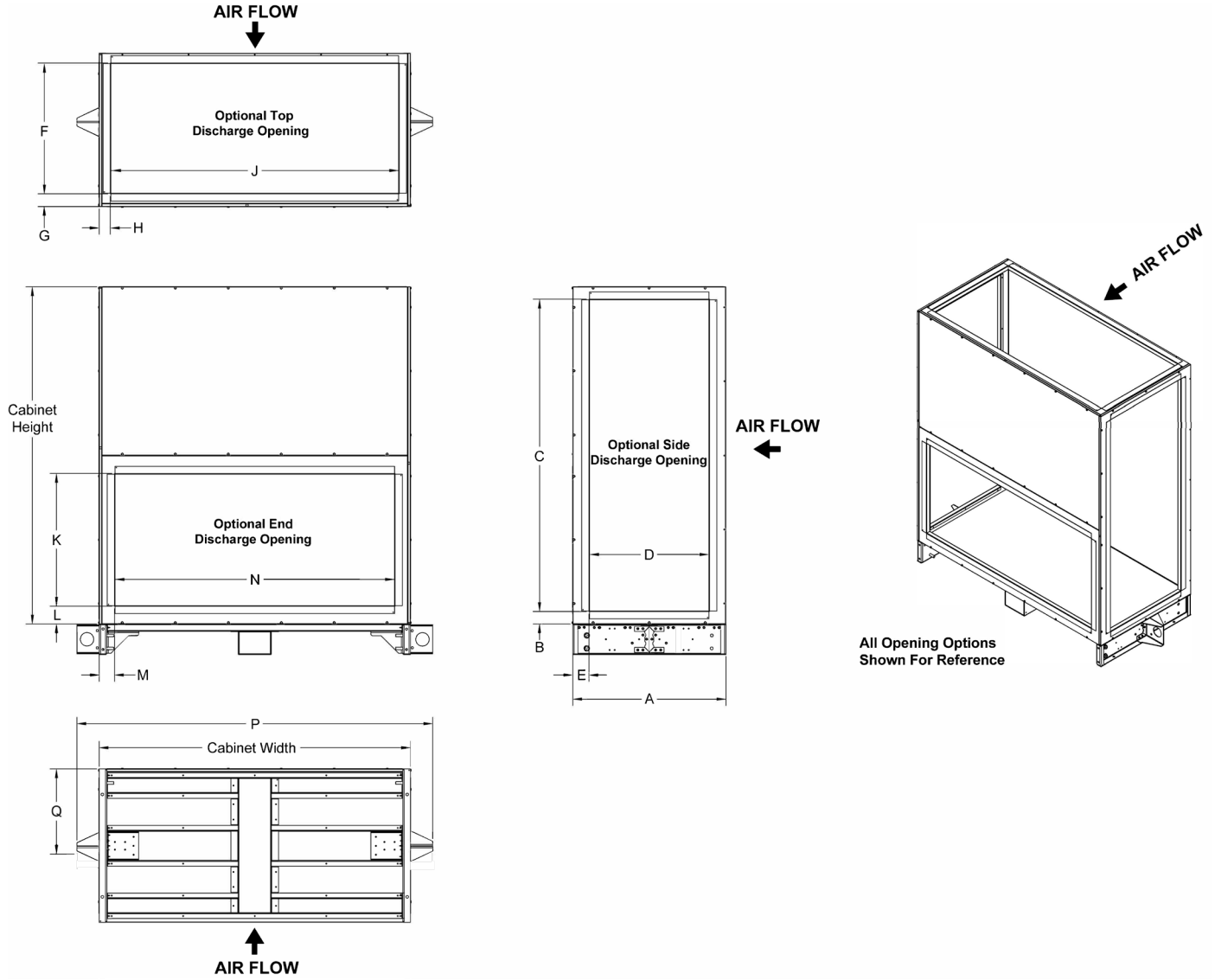

NOTE: Dimensions shown in inches.

Table 79: Discharge Plenum Without Filter Dimension Letter Reference

Dimension	060	080	100
A	30.00	30.00	30.00
B	3.00	7.00	2.50
C	48.00	48.00	61.00
D	18.00	24.00	23.50
E	7.16	2.99	3.23
F	20.00	24.00	26.00
G	2.60	3.25	2.50
H	7.50	3.00	2.25
J	43.00	48.00	55.00

Dimension	060	080	100
K	20.00	24.00	26.00
L	3.49	3.49	3.46
M	5.50	3.00	3.00
N	43.00	48.00	55.00
P	62.75	62.75	69.75
Q	16.61	16.61	16.61
Length	30	30	30
Width	54	54	61
Height	54	62	66

NOTE: Dimensions shown in inches.

Figure 55: Discharge Plenum With Filter (Unit Sizes 060-100)

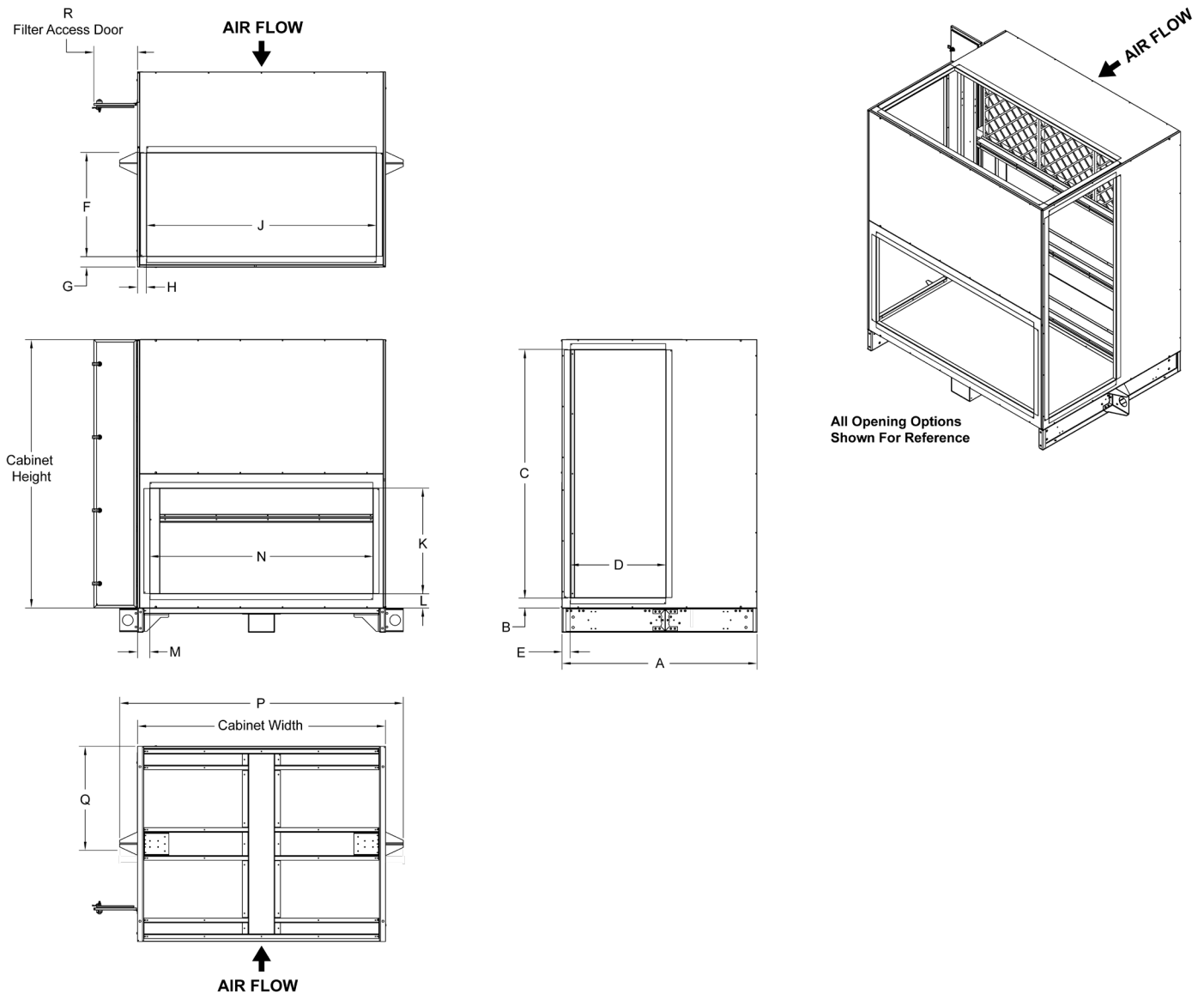

NOTE: Dimensions shown in inches.

Table 80: Discharge Plenum With Filter Dimension Letter Reference

Dimension	060	080	100
A	48.00	48.00	48.00
B	3.00	7.00	2.50
C	48.00	48.00	61.00
D	18.00	24.00	23.50
E	4.81	3.06	2.06
F	20.00	24.00	26.00
G	2.60	2.60	2.06
H	7.50	3.00	2.25
J	43.00	48.00	55.00
K	20.00	24.00	26.00

Dimension	060	080	100
L	3.49	3.49	3.46
M	5.50	3.00	3.00
N	43.00	48.00	55.00
P	62.75	62.75	69.75
Q	25.61	25.61	25.61
R	10.73	10.73	10.73
Length	48	48	48
Width	54	54	61
Height	54	62	66

NOTE: Dimensions shown in inches.

Figure 56: Horizontal Exhaust Air / Outdoor Air Dimensions (Unit Sizes 060-100)

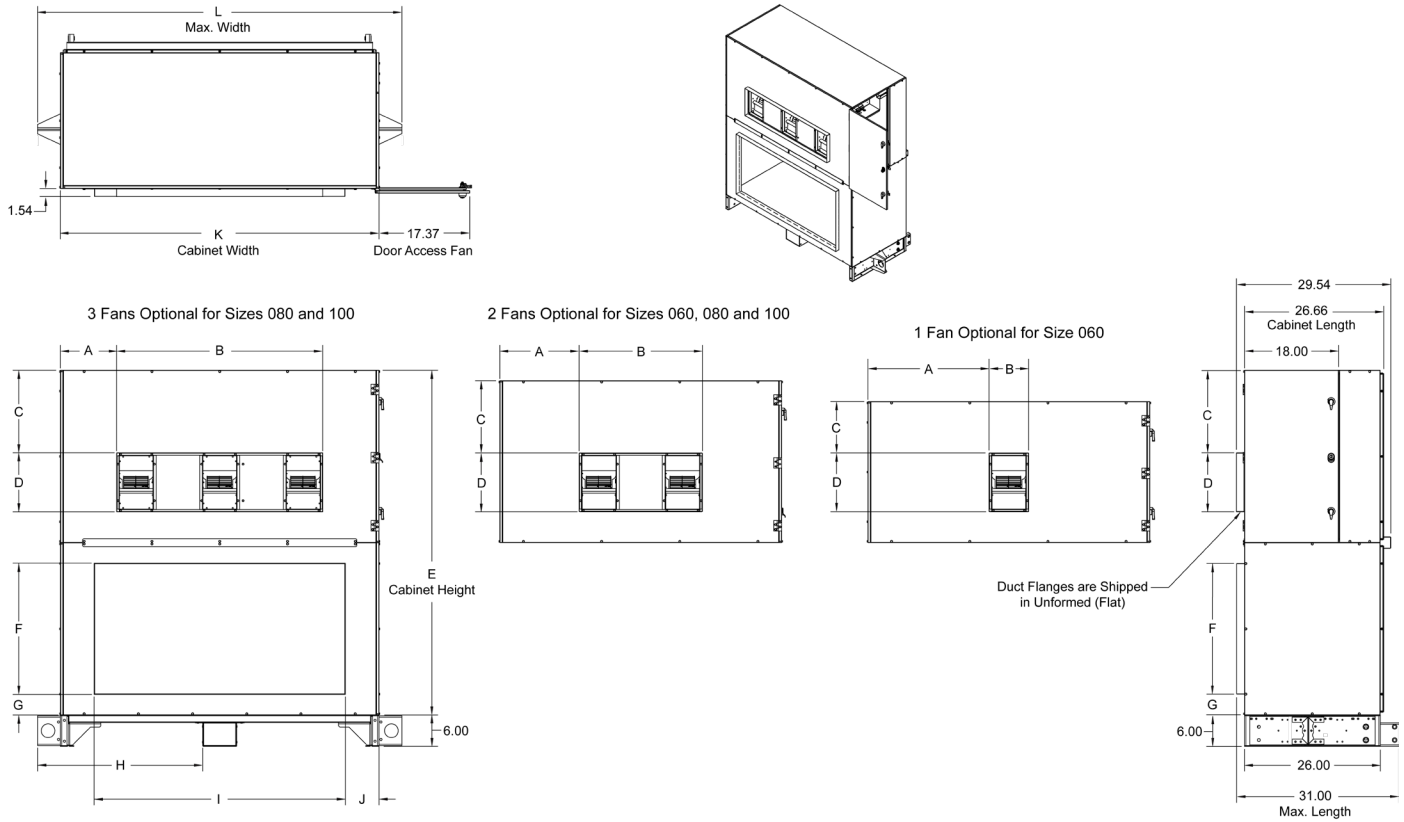

NOTE: Dimensions shown in inches.

Table 81: Exhaust Air / Outdoor Air Section Dimension Letter Reference

Dimension	060		080		100	
	1 Fan	2 Fans	2 Fans	3 Fans	2 Fans	3 Fans
A	23.20	15.20	15.20	7.20	18.75	10.75
B	7.60	23.60	23.60	39.61	23.50	39.61
C	9.84	9.84	13.84	13.81	15.84	15.81
D	11.26	11.26	11.26	11.26	11.26	11.26
E	54.00		62.00		66.00	
F	20.00		24.00		25.00	
G	3.50		3.50		4.00	
H	23.75		23.75		31.63	
I	36.00		40.00		48.00	
J	9.00		7.00		6.50	
K	54.00		54.00		61.00	
L	62.75		62.75		69.75	

NOTE: Dimensions shown in inches.

Figure 57: Vertical Exhaust Air / Outdoor Air Dimensions - Two Fans (Unit Sizes 060-100)

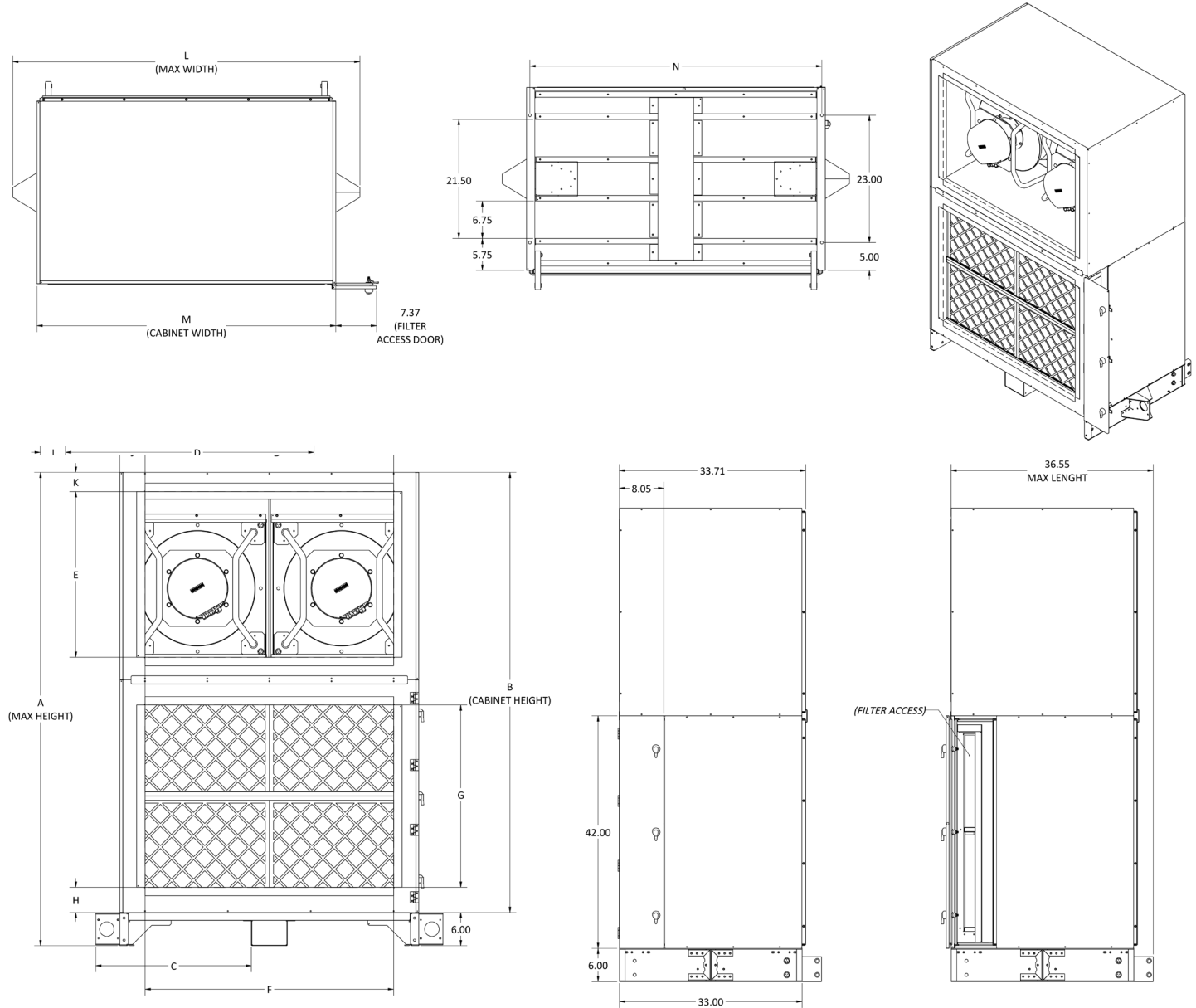

NOTE: Dimensions shown in inches.

Table 82: Exhaust Air / Outdoor Air Section - Two Fans Dimension Letter Reference

Dimension	060	080	100
	2 Fans		
A	85.50	85.50	85.50
B	79.50	79.50	79.50
C	28.13	28.13	28.13
D	41.53	34.53	44.91
E	18.78	32.78	29.91
F	41.53	34.53	44.91
G	18.78	32.78	32.91

Dimension	060	080	100
	2 Fans		
H	4.62	4.62	11.61
J	6.23	9.73	4.55
K	9.06	2.06	3.49
L	62.75	62.75	62.75
M	54.00	54.00	54.00
N	52.76	52.76	52.76

NOTE: Dimensions shown in inches.

Figure 58: Vertical Exhaust Air / Outdoor Air Dimensions - One Fan (Unit Sizes 060-100)

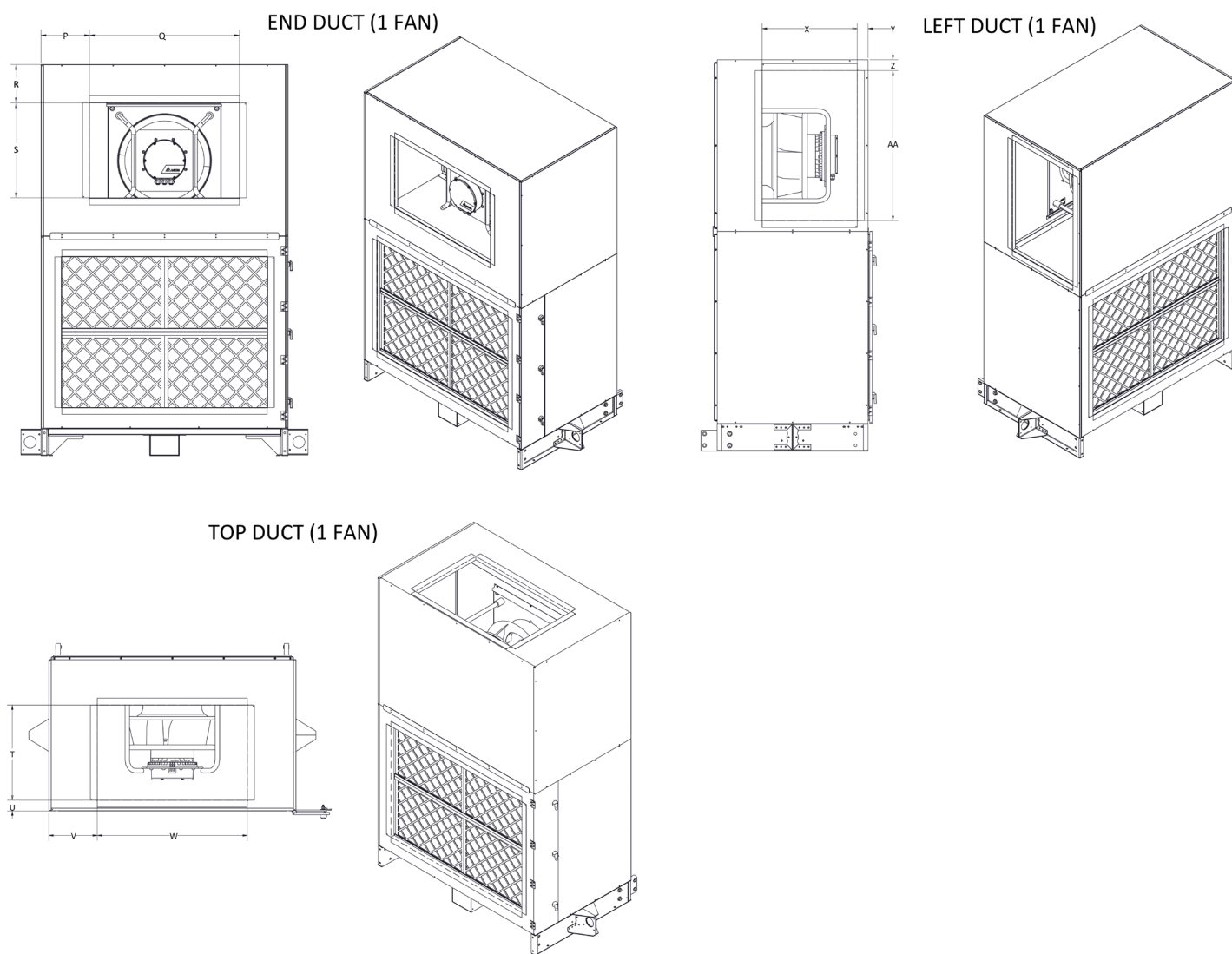

NOTE: Dimensions shown in inches.

Table 83: Exhaust Air / Outdoor Air Section - One Fan Dimension Letter Reference

Dimension	060	080	100
	1 Fan		
P	13.61	12.11	10.61
Q	26.78	29.78	32.78
R	11.11	9.86	8.36
S	14.78	17.78	20.78
T	14.78	17.78	20.78
U	3.73	3.73	2.27
V	13.61	12.11	10.61
W	26.78	29.78	32.78
X	14.78	17.78	20.78
Y	3.73	3.73	2.36
Z	5.36	3.86	2.36
AA	26.78	29.78	32.78

NOTE: Dimensions shown in inches.

Figure 59: Vertical Exhaust Air / Outdoor Air Dimensions - Two Fans / Electric Heat (Unit Sizes 060-100)

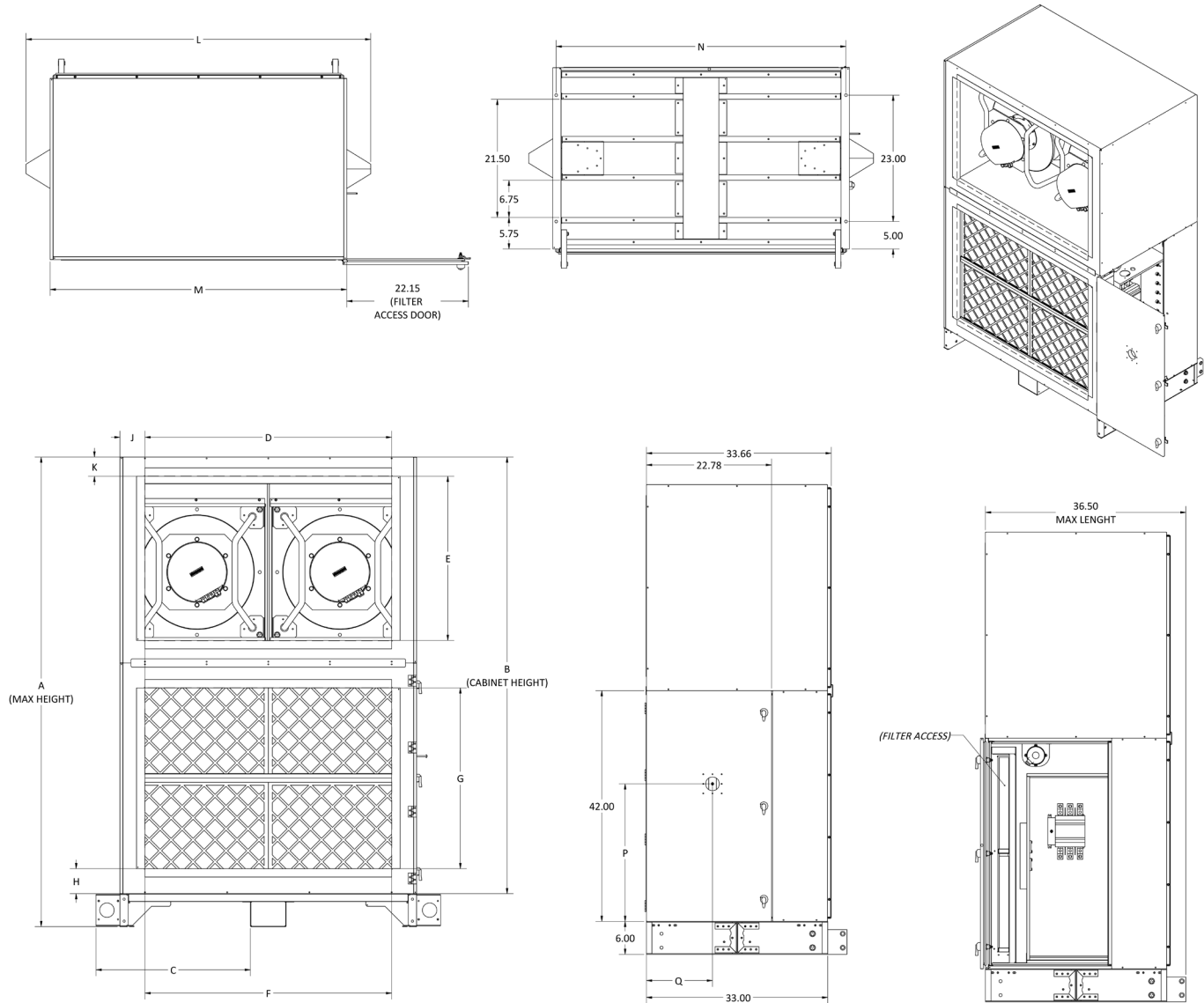

NOTE: Dimensions shown in inches.

Table 84: Exhaust Air / Outdoor Air Section - Two Fans / Electric Heat Dimension Letter Reference

Dimension	060	080	100
	2 Fans		
A	85.50	85.50	85.50
B	79.50	79.50	79.50
C	28.13	28.13	28.13
D	41.53	34.53	44.91
E	18.78	32.78	29.91
F	41.53	34.53	44.91
G	18.78	32.78	32.91
H	4.62	4.62	11.61

Dimension	060	080	100
	2 Fans		
J	6.23	9.73	4.54
K	9.06	2.06	3.49
L	62.75	62.75	62.75
M	54.00	54.00	54.00
N	52.76	52.76	52.76
P	25.04	25.04	25.04
Q	12.03	12.03	12.03

NOTE: Dimensions shown in inches.

Figure 60: Vertical Exhaust Air / Outdoor Air Dimensions - Two Fans / Hot Water (Unit Sizes 060-100)

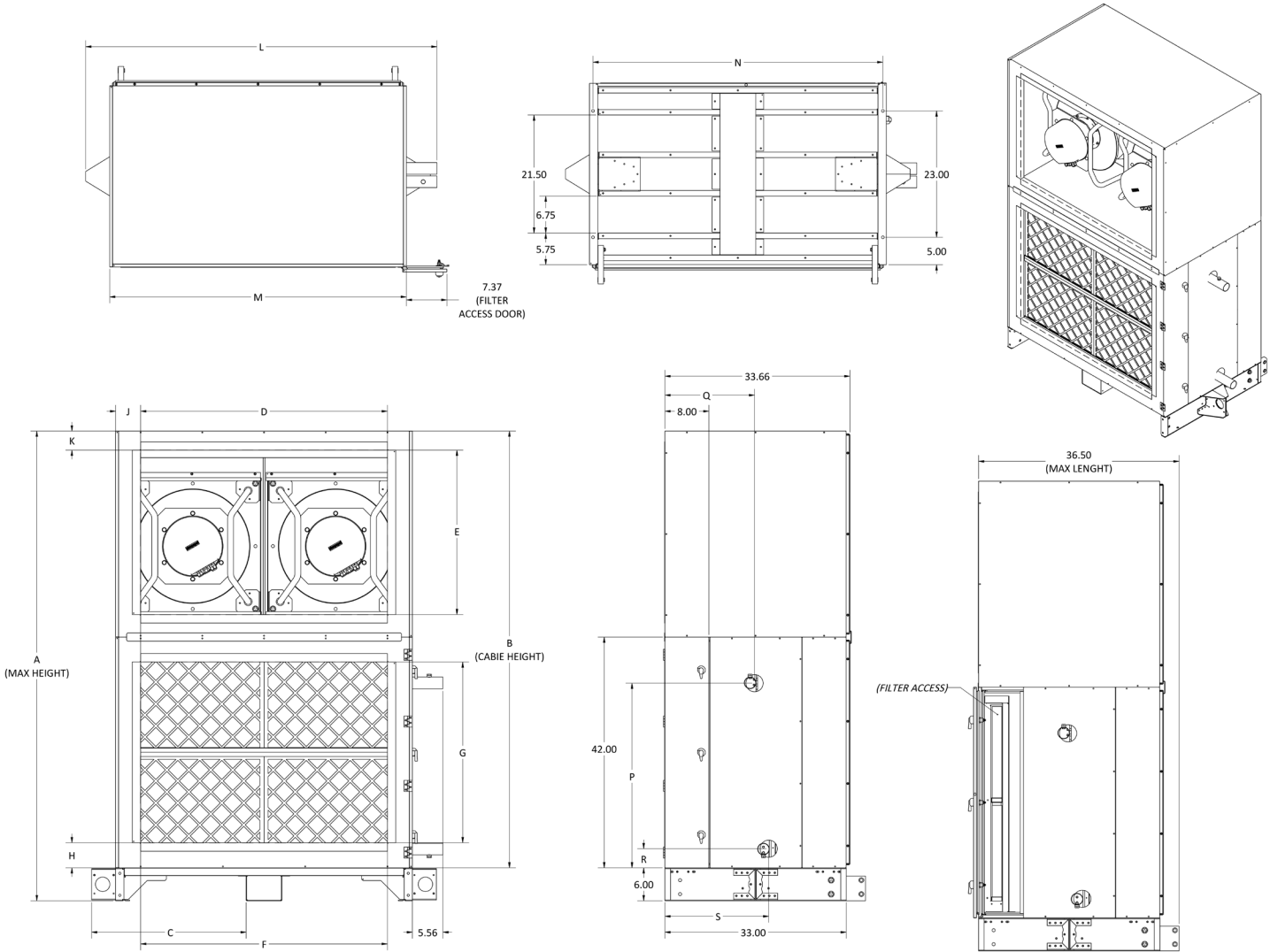

NOTE: Dimensions shown in inches.

Table 85: Exhaust Air / Outdoor Air Section - Two Fans / Hot Water Dimension Letter Reference

Dimension	060		080		100	
	1 Fan	2 Fans	2 Fans	3 Fans	2 Fans	3 Fans
A	85.50		85.50		85.50	
B	79.50		79.50		79.50	
C	28.13		28.13		28.13	
D	41.53		34.53		44.91	
E	18.78		32.78		29.91	
F	41.53		34.53		44.91	
G	18.78		32.78		32.91	
H	4.62		4.62		4.56	
J	6.23		9.73		4.55	

Dimension	060		080		100	
	1 Fan	2 Fans	2 Fans	3 Fans	2 Fans	3 Fans
K	9.06		2.06		3.49	
L	63.94		62.75		63.94	
M	54.00		54.00		54.00	
N	52.76		52.76		52.76	
P	19.57	19.67	25.67	25.67	33.67	33.67
Q	15.24	15.24	15.24	15.24	16.17	15.51
R	3.42	3.42	3.42	3.42	3.92	3.42
S	18.04	17.93	17.93	17.93	18.97	17.93

NOTE: Dimensions shown in inches.

Figure 61: Horizontal Economizer Dimensions (Unit Sizes 060-100)

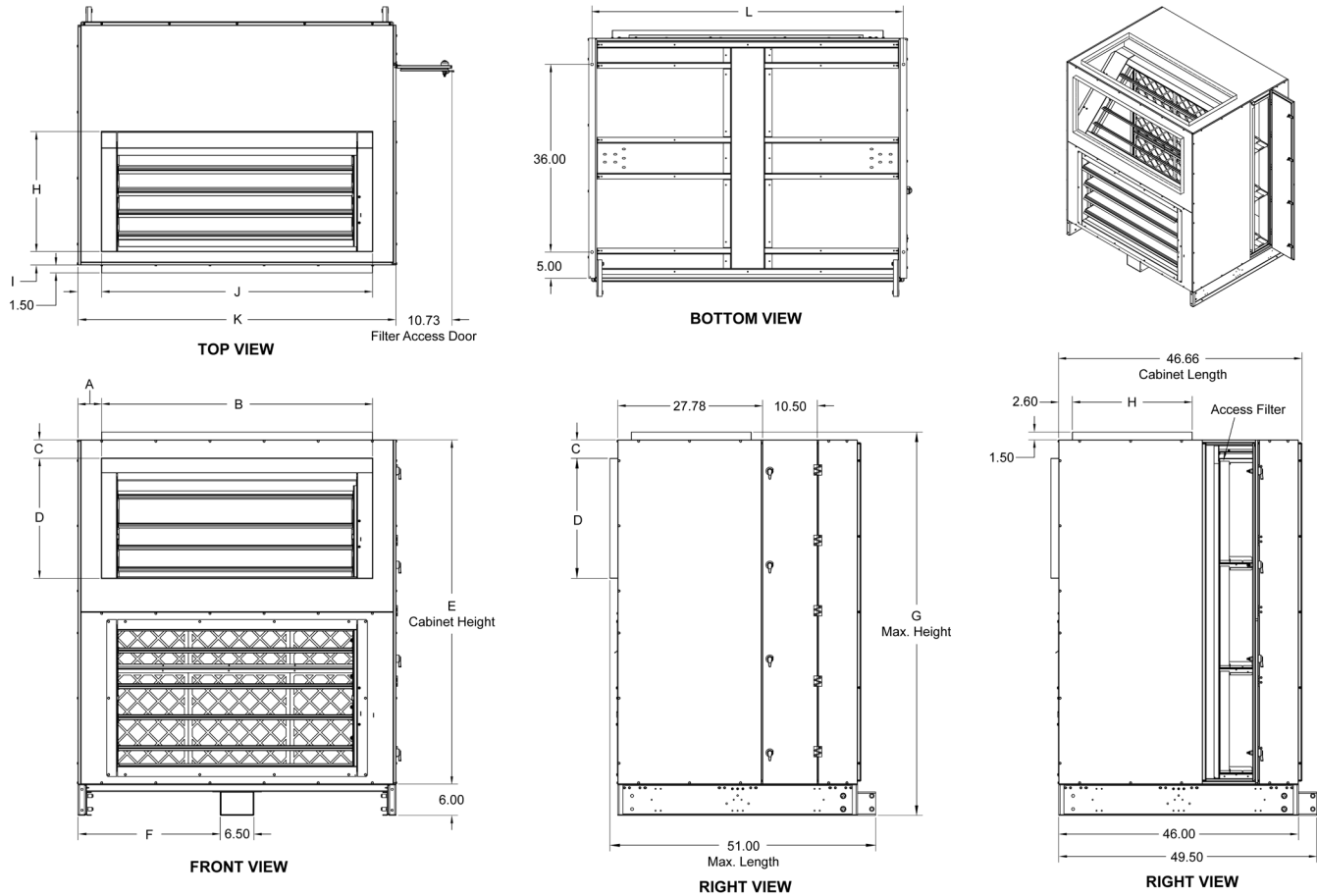

NOTE: Dimensions shown in inches.

Table 86: Economizer Section Dimension Letter Reference

Dimension	060	080	100
A	7.00	5.00	4.50
B	40.00	44.00	52.00
C	54.00	62.00	66.00
D	23.75	23.75	27.25
E	61.50	69.50	73.50
F	18.00	22.00	23.19
G	54.00	54.00	61.00
H	52.76	52.76	59.76
I	6.50	4.00	4.50
J	40.00	46.00	52.00
K	54.00	54.00	61.00
L	52.76	52.76	59.76

NOTE: Dimensions shown in inches.

Figure 62: Vertical Economizer End Section Dimensions (Unit Sizes 060-100)

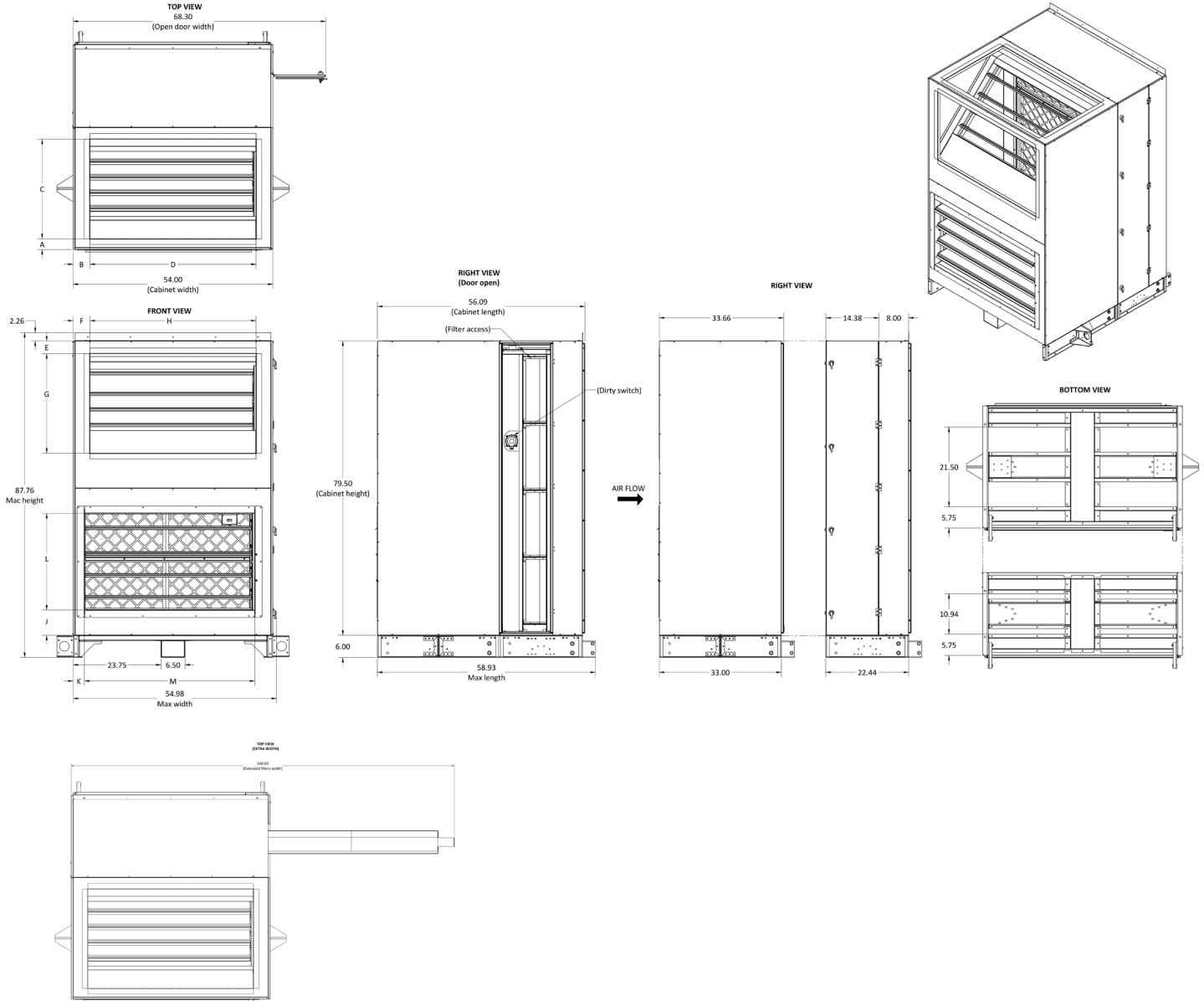

NOTE: Dimensions shown in inches.

Table 87: Economizer End Section Dimension Letter Reference

Dimension	060	080	100
A	9.56	2.39	2.39
B	6.23	4.55	4.55
C	18.78	21.91	26.9
D	41.53	44.9	44.9
E	3.41	3.41	3.41
F	6.23	4.55	4.55

Dimension	060	080	100
G	18.78	21.91	26.9
H	41.53	44.9	44.9
J	8.83	8.83	6.81
K	10.19	4.94	3.07
L	22.07	22.07	26.11
M	33.63	44.13	46.03

NOTE: Dimensions shown in inches.

Figure 63: Vertical Economizer Dimensions (Unit Sizes 060-100)

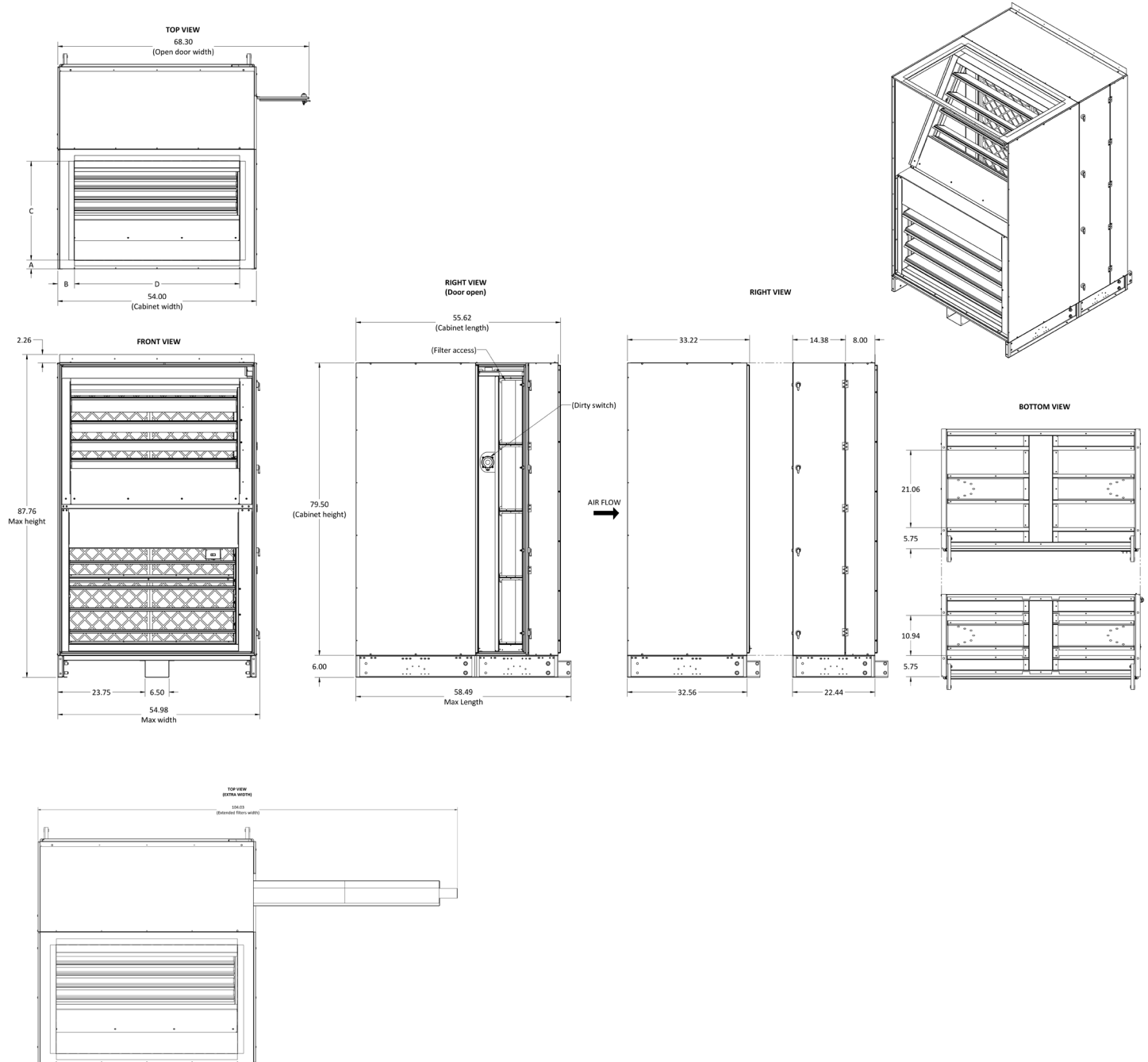

NOTE: Dimensions shown in inches.

Table 88: Economizer Section Dimension Letter Reference

Dimension	060	080	100
A	9.56	2.39	2.39
B	6.23	4.55	4.55
C	18.78	21.91	26.9
D	41.53	44.9	44.9

NOTE: Dimensions shown in inches.

Figure 64: Return Filter Dimensions (Unit Sizes 060-100)

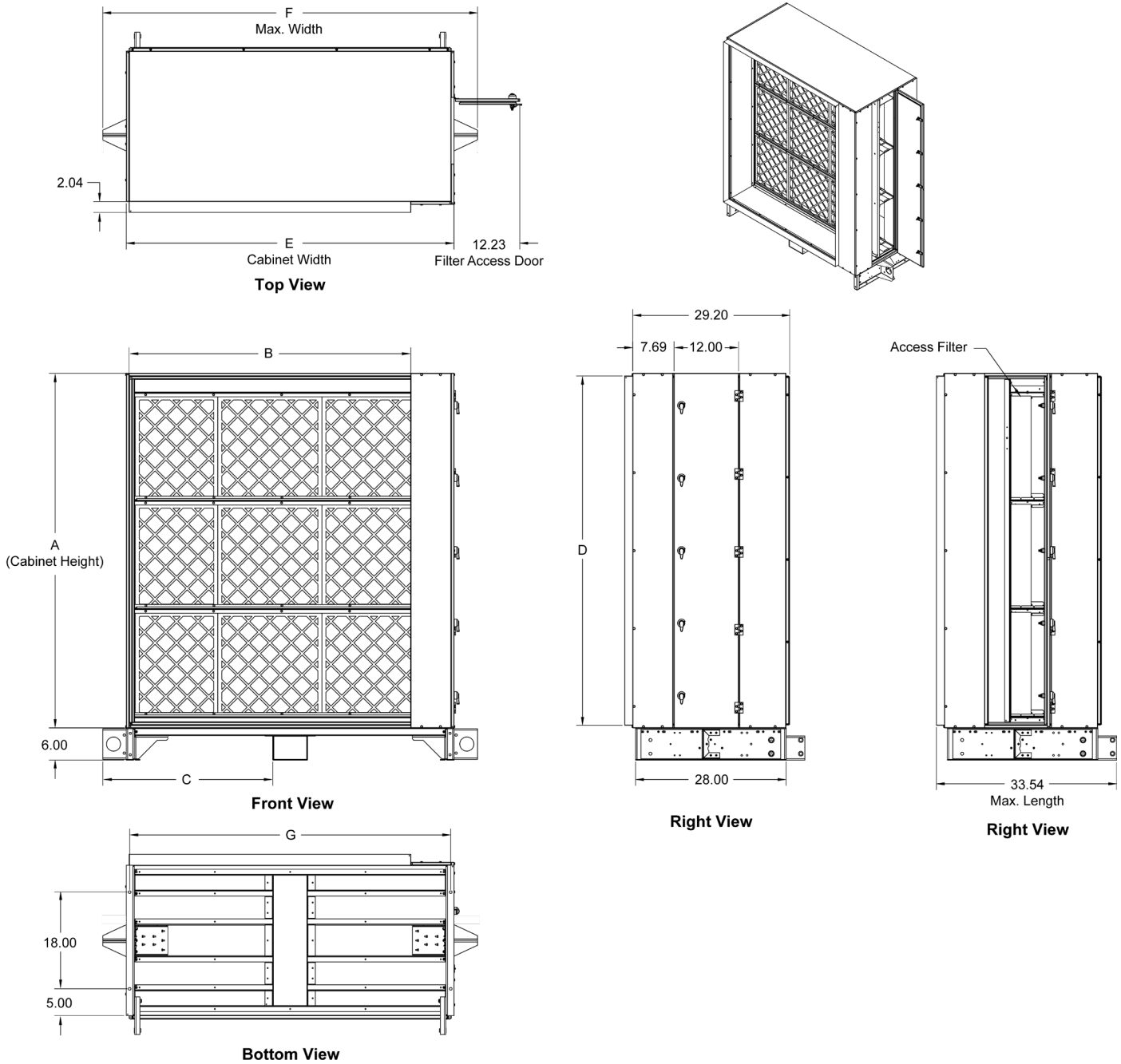

NOTE: Dimensions shown in inches.

Table 89: Return Filter Section Dimension Letter Reference

Dimension	060	080	100
A	54.00	62.00	66.00
B	45.36	45.36	52.36
C	28.13	28.13	31.63
.D	52.88	60.88	64.88
E	54.00	54.00	61.00
F	62.75	62.75	69.75
G	52.76	52.76	59.76

NOTE: Dimensions shown in inches.

Figure 65: Electric Heat Section Dimensions (Unit Sizes 060-100)

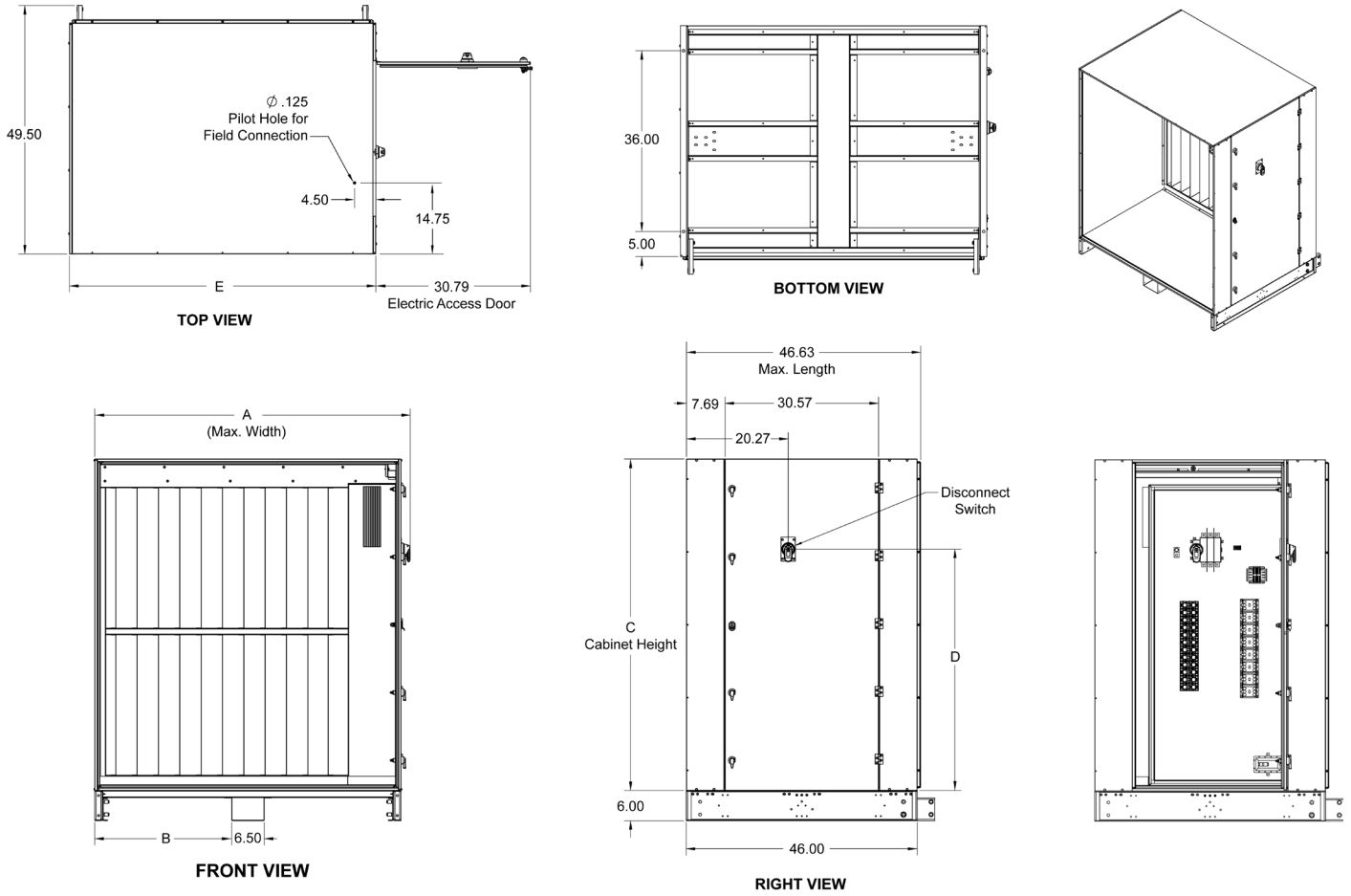

NOTE: Dimensions shown in inches.

Table 90: Electric Heat Section Dimension Letter Reference

Dimension	060	080	100
A	55.82	55.82	62.82
B	23.75	23.75	27.25
C	54.00	62.00	66.00
D	36.04	44.04	46.73
E	54.00	54.00	61.00

NOTE: Dimensions shown in inches.

Figure 66: Horizontal Supply Air Fan Section Dimensions (Unit Sizes 060-100)

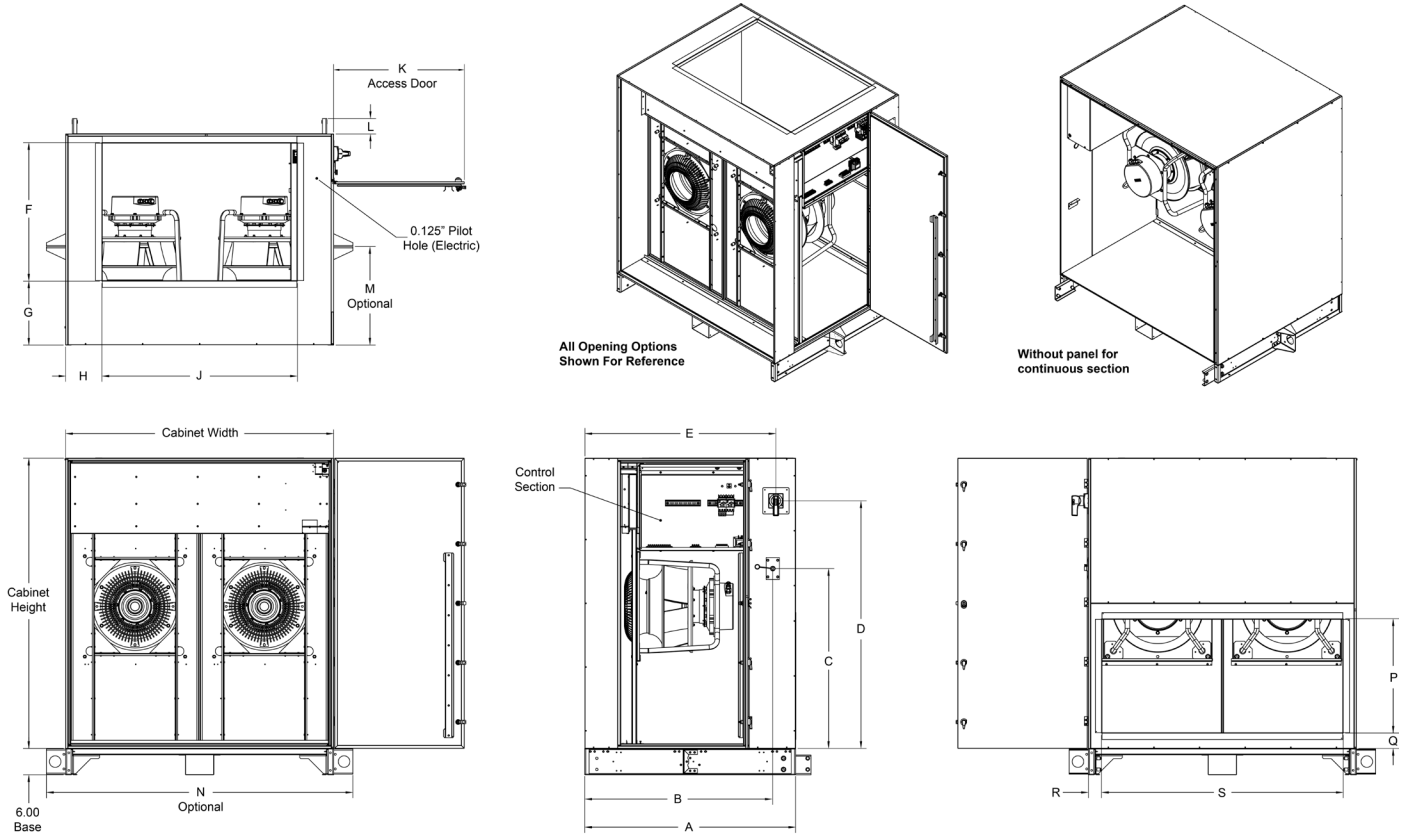

NOTE: Dimensions shown in inches.

Table 91: Supply Air Fan Section Dimension Letter Reference

Dimension	060	080	100
A	48.00	48.00	48.00
B	43.65	43.65	43.65
C	36.65	44.64	48.64
D	44.08	52.08	56.07
E	43.65	43.65	43.65
F	29.50	31.00	31.38
G	15.87	14.37	14.57
H	12.25	8.50	8.31
J	29.50	37.00	44.38
K	29.73	29.73	29.73
L	3.50	3.50	3.50
M	22.39	22.39	22.39
N	62.75	62.75	69.75
P	20.00	26.00	26.00
Q	3.49	2.49	3.46
R	5.50	5.00	3.00
S	43.00	44.00	55.00

NOTE: Dimensions shown in inches.

Figure 67: Energy Recovery Wheel - 46 in (Unit Sizes 060-100)

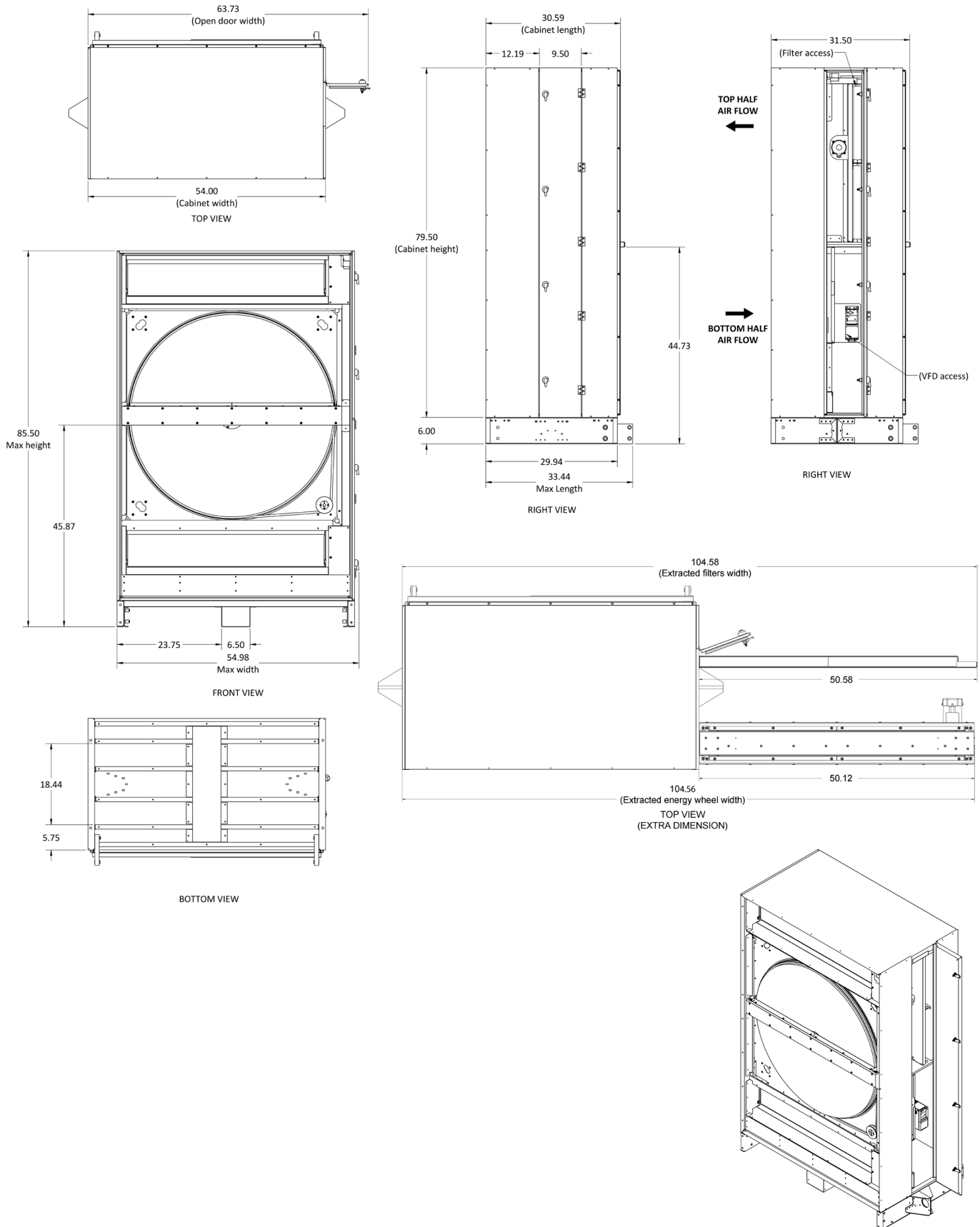

NOTE: Dimensions shown in inches.
ED 19140-3

Figure 68: Energy Recovery Wheel - 52 in (Unit Sizes 060-100)

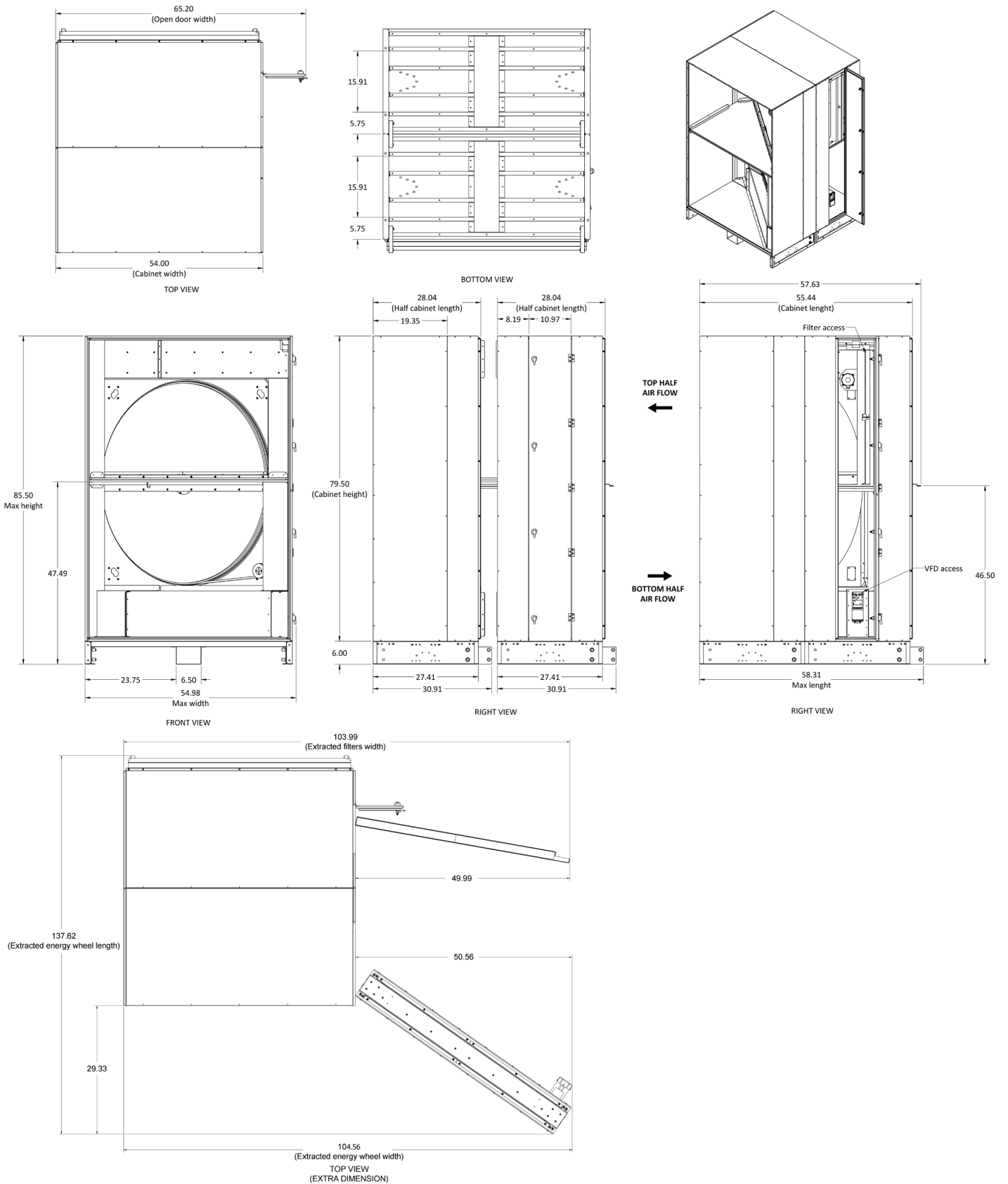

NOTE: Dimensions shown in inches.

Figure 69: Energy Recovery Wheel - 58 in (Unit Sizes 060-100)

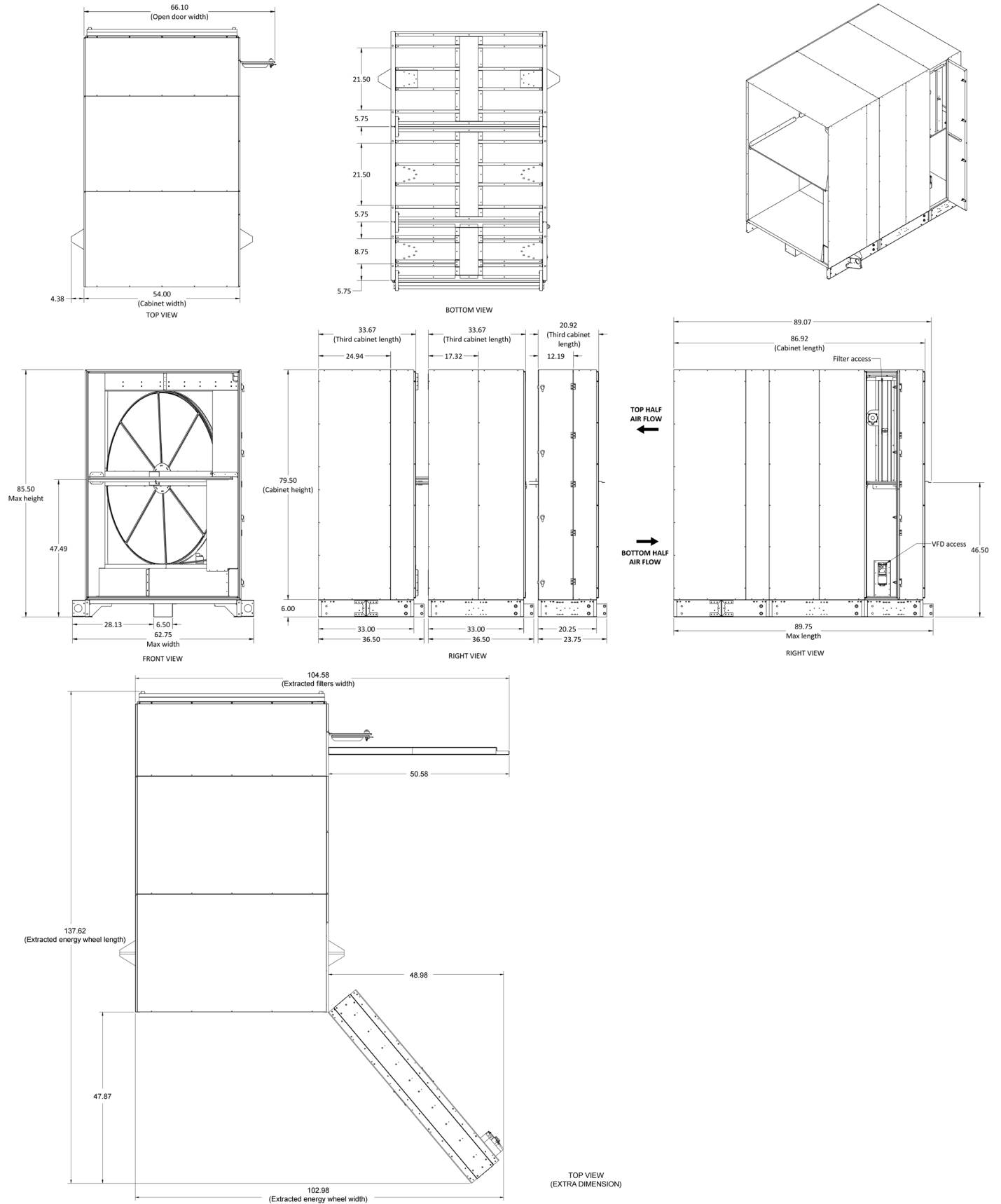

NOTE: Dimensions shown in inches.

System Considerations

Operation Limitations

Leaving Air Temperature

Daikin Applied's PreciseLine is a draw thru style air handler which means the fan housing and motor assembly are in the conditioned part of the air stream. Coil leaving air temperatures over 125°F (52°C) are not recommended and threaten the longevity of the unit.

Entering Air Temperatures

The coils used in PreciseLine are not suitable for exposure to freezing temperatures. Proper consideration must be taken to

keep the air temperature seen by the coil above the freezing point of the coil's working fluid. Units with a mixing box must be especially careful because large temperature differences between return air and outdoor air can leave the coil vulnerable through air stratification.

Entering Water Temperatures

Entering water temperatures above 200°F (93°C) are not recommended as PreciseLine's coils are tested and rated to 200°F (93°C) in accordance with UL 1995.

Voltage Variance

To preserve longevity of electrical components supplied voltage must be within 10% of the nominal nameplate voltage.

Table 92: Small Horizontal Hydronic Coil Size and Connection Type - Unit Sizes 060-020

Unit Size	006		008		010		012		016		018		020	
	FPT (Nominal)	SWT (OD)	FPT (Nominal)	SWT (OD)	FPT (Nominal)	SWT (OD)	FPT (Nominal)	SWT (OD)	FPT (Nominal)	SWT (OD)	FPT (Nominal)	SWT (OD)	FPT (Nominal)	SWT (OD)
2-Row Cooling	0.500	0.625	0.500	0.625	0.500	0.625	0.500	0.625	0.750	0.875	0.750	0.875	0.750	0.875
4-Row Cooling	0.500	0.625	0.500	0.625	0.750	0.875	0.750	0.875	0.750	0.875	1.000	1.125	1.000	1.125
6-Row Cooling	0.500	0.625	0.500	0.875	0.750	0.875	0.750	0.875	1.000	1.125	1.000	1.125	1.000	1.125
1-Row Preheat/Reheat	0.500	0.625	0.500	0.625	0.500	0.625	0.500	0.625	0.500	0.625	0.500	0.625	0.500	0.625
2-Row Preheat/Reheat	0.500	0.625	0.500	0.625	0.500	0.625	0.500	0.625	0.750	0.875	0.750	0.875	0.750	0.875

NOTE 1: On small horizontal units, piping terminates inside the cabinet when sweat connections are selected and outside the cabinet when threaded connections are selected.

NOTE 2: Dimensions shown in inches.

Table 93: Medium and Large Horizontal Hydronic Coil Size and Connection Type - Unit Sizes 030-100

Unit Size	030	040	050	060	080	100
Connection Type	SWT (OD)					
2-Row Cooling	1.125	1.125	1.375	1.125	1.125	1.375
4-Row Cooling	1.375	1.625	1.625	1.375	1.625	1.625
6-Row Cooling	1.375	1.625	1.625	1.375	1.625	1.625
8-Row Cooling	1.375	1.625	1.625	1.375	1.625	1.625
1-Row Preheat/Reheat	0.625	0.875	1.125	0.625	0.875	1.125
2-Row Preheat/Reheat	1.125	1.125	1.375	1.125	1.125	1.375

NOTE: Dimensions shown in inches.

Table 94: Small Vertical Hydronic Coil Size and Connection Type - Unit Sizes 060-020

Unit Size	006		008		012		016		020	
	FPT (Nominal)	SWT (OD)	FPT (Nominal)	SWT (OD)	FPT (Nominal)	SWT (OD)	FPT (Nominal)	SWT (OD)	FPT (Nominal)	SWT (OD)
2-Row Cooling	0.500	0.625	0.500	0.625	0.500	0.625	0.750	0.875	0.750	0.875
4-Row Cooling	0.500	0.625	0.500	0.625	0.750	0.875	0.750	0.875	1.000	1.125
6-Row Cooling	0.500	0.625	0.500	0.875	0.750	0.875	1.000	1.125	1.000	1.125
1-Row Preheat/Reheat	0.500	0.625	0.500	0.625	0.500	0.625	0.500	0.625	0.500	0.625
2-Row Preheat/Reheat	0.500	0.625	0.500	0.625	0.500	0.625	0.750	0.875	0.750	0.875

NOTE 1: On small vertical units, piping always terminates inside the cabinet. It can be selected with sweat connections or threaded connections.

NOTE 2: Dimensions shown in inches.

Table 95: Medium and Large Vertical Hydronic Coil Size and Connection Type - Unit Sizes 030-100

Unit Size	030	040	050	060	080	100	060	080	100
Connection Type	SWT (OD)						SWT (OD)*		
2-Row Cooling	1.125	1.375	1.375	1.625	1.625	1.625	1.500	1.500	1.500
4-Row Cooling	1.375	1.625	1.625	1.625	1.625	1.625	1.500	1.500	1.500
6-Row Cooling	1.625	1.625	2.125	1.625	1.625	1.625	1.500	1.500	1.500
8-Row Cooling	1.625	2.125	2.125	1.625	1.625	2.125	1.500	1.500	1.500
1-Row Preheat/Reheat	0.625	0.875	1.125	1.625	1.625	1.625	-	-	-
2-Row Preheat/Reheat	1.125	1.375	1.375	1.625	2.125	2.125	-	-	-

NOTE 1: *Large vertical units can be selected with TurboSpiral coils designed for use with glycol. These coils have a SWT connection.

NOTE 2: Number of connections in unit sizes 060-100 are doubled (stacked).

NOTE 3: Dimensions shown in inches.

Table 96: Vertical Steam Coil Size and Type

Unit Size	006	008	012	016	020	030	040	050
Connection Type	SWT (OD)							
Supply	1.125	1.125	1.125	1.125	1.125	1.125	1.125	1.375
Return	0.875	0.875	0.875	0.875	0.875	1.125	1.125	1.375

NOTE: Dimensions shown in inches.

Table 97: Horizontal Steam Coil Size and Type with Piping

Unit Size	006	008	010	012	016	018	020	030	040	050	060	080	100
Connection Type	FPT (Nominal)							SWT (OD)					
Supply	0.750	0.750	0.750	0.750	0.750	0.750	0.750	1.125	1.125	1.375	1.125	1.125	1.375
Return	0.500	0.500	0.500	0.500	0.500	0.500	0.500	1.125	1.125	1.375	1.125	1.125	1.375

NOTE 1: Number of connections in unit sizes 060-100 are doubled (stacked).

NOTE 2: Steam coil connections are inside the cabinet on sizes 006 - 020 and outside the cabinet on sizes 030 - 100.

NOTE 3: Dimensions shown in inches.

Table 98: Horizontal Steam Coil Size and Type with No Piping

Unit Size	006	008	010	012	016	018	020
Connection Type	FPT (Nominal)						
Supply	0.750	0.750	0.750	0.750	0.750	0.750	0.750
Return	0.500	0.500	0.500	0.500	0.500	0.500	0.500
Coil Size							
Finned Height	12	12	12	12	12	12	12
Finned Length	6.5	10.5	19	19	27	35.5	35.5

NOTE 1: FPI of 10 may be selected.

NOTE 2: Dimensions shown in inches.

Table 99: Horizontal DX Coil Size and Type - R-32 and R-454B

Unit Size	Rows ¹	Circuits		Connection Size (SWT [OD]) ³		Volume (cu in)
		Number ²	Type	Distributor	Suction	
006	3	1	Normal	0.500	0.750	65
008	3	1	Normal	0.500	0.750	81
010	3	1	Normal	0.500	0.875	115
012	3	1	Normal	0.500	0.875	115
016	3	1	Normal	0.500 (R-32)	1.125	147
				0.625 (R-454B)		
018	3	1	Normal	0.500	1.125	194
020	3	1	Normal	0.500	1.125	194
030	3	1	Normal	0.875	1.375	303
		2	Interlaced	0.500	0.875	300
040	3	1	Normal	0.875	1.375	395
		2	Interlaced	0.625	1.125	415
050	3	1	Normal	0.875	1.625	523
		2	Interlaced	0.625	1.375	534
060	3	2	Normal	0.875	1.375	607
		4	Interlaced	0.500	0.875	600
080	3	2	Normal	0.875	1.375	791
		4	Interlaced	0.625	1.125	830
100	3	2	Normal	0.875	1.625	1045
		4	Interlaced	0.625	1.375	1068

¹ FPI of 12 or 16 may be selected.

² Number of connections in unit sizes 060-100 are doubled (stacked).

³ Dimensions shown in inches.

Table 100: Vertical DX Coil Size and Type - R-32 and R-454B

Unit Size	Rows ¹	Circuits		Connection Size (SWT [OD]) ³		Volume (cu in)
		Number ²	Type	Distributor	Suction	
006	3	1	Normal	0.500	0.875	65
	6	1	Normal	0.500	0.875	121
008	3	1	Normal	0.500	0.875	84
	6	1	Normal	0.500	0.875	169
012	3	1	Normal	0.500	1.125	129
	6	1	Normal	0.625	1.125	233
016	3	1	Normal	0.625	1.125	172
	6	1	Normal	0.625 (R-32) 0.875 (R-454B)	1.125	315
020	3	1	Normal	0.625 (R-32) 0.875 (R-454B)	1.375	188
	6	1	Normal	0.875	1.375	392
030	3	1	Normal	0.875	1.625	284
		2	Interlaced	0.500 (R-32) 0.625 (R-454B)	0.875	284
	6	2	Interlaced	0.875	1.125	611
040	3	1	Normal	0.875	1.625	458
		2	Interlaced	0.625 (R-32) 0.875 (R-454B)	1.375	460
	6	2	Interlaced	0.625 (R-32) 0.875 (R-454B)	1.375	728
050	3	1	Normal	0.875	1.625	579
	2	Interlaced	0.875	1.375	581	
	6	2	Interlaced	0.875	1.625	1159
060	3	2	Normal	0.875	1.375	540
		4	Interlaced	0.875	0.875	540
	6	2	Interlaced	0.875	1.125	1091
080	3	2	Normal	0.875	1.375	730
		4	Interlaced	0.625	1.125	730
	6	2	Interlaced	0.875	1.375	1474
100	3	2	Normal	0.875	1.625	918
		4	Interlaced	0.875	1.375	918
	6	2	Interlaced	0.875	1.375	1855

¹ FPI of 12, 14, or 16 may be selected.

² Number of connections in unit sizes 060-100 are doubled (stacked).

³ Dimensions shown in inches.

Application Considerations

MicroTech 4 Lite Factory-Integrated Controller

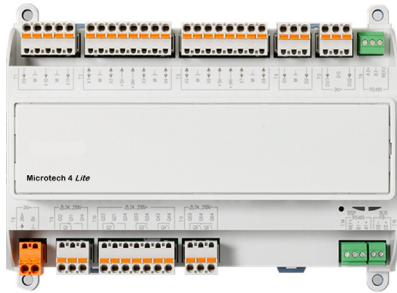

The factory-integrated controller simplifies startup and reduces controls complexity by utilizing proven factory controls schemes.

- Provides standalone or BAS integrated air handler control.
- Comprehensive unit control and status information is available to the BAS via BACnet MS/TP.
- Easy monitoring and troubleshooting via the integrated thermostat, BAS, or portable interface.

Table 101: Controller Accessories Available

Controller Accessory	Installation Method	Function Affected
Damper Actuator	Factory	Damper
Freezestat	Factory	Alarm Only
Condensate Overflow Switch	Factory	Cool / Dehumidification
Outdoor Temp and Humidity Combo Sensor	Field	Economizer
Outdoor Temperature Only Sensor	Field	Economizer
Room Sensor	Field	Temp & Setpoints
Space Humidity Sensor	Field	Dehumidification / Economizer
Airflow Status	Field	Alarm Only
Discharge Air Temperature Sensor	Field	Cool / Heat / Reheat
Leaving Coil Temperature Sensor	Field	Dehumidification
Duct Static Pressure Sensor	Field	Fan Speed
Entering Water Temperature Sensor (2-Pipe)	Field	Cool / Heat

Controller Components

Portable Interface



The portable interface connects to units via a factory-mounted RJ45 cable to an external cabinet connection port, providing convenient access for diagnostics and controls adjustments.

Each portable interface offers the following functionalities:

- Push-and-roll navigation wheel with an 8-line by 30-character display format
- Digital display of messages in English language
- All operating conditions, system alarms, control parameters and schedules are monitored

Integrated Thermostat



The integrated thermostat allows occupants to manage unit functions, including:

- Scheduling and setting temporary cooling/heating set points
- Adjusting fan speed for constant volume units
- Request temporary set points

Controller Functions

Fan Speed Control

Supply fan control to meet your building needs.

Supply Fan Control Methods

- Constant volume
- Duct static pressure
- Single-zone VAV

Cooling and Heating Control

Ensure comfort and efficiency by selecting the preferred mode control and modulation that fits your application.

Hydronic Systems (2-pipe changeover or 4-pipe)

- Normally Open/Closed 24 VAC or 0-10 VDC modulation
- Entering water sampling (2-pipe changeover only)
 - For changeover configurations, verify entering water temperature is within range for cooling / heating request.

Electric Heat

- Staged or SCR modulation

Dehumidification Control

PreciseLine units with factory-integrated controllers offer two strategies for space dehumidification.

Strategy 1: Active Dehumidification

Active dehumidification adds a reheat component to achieve desired discharge air temperatures. After the supply air is dehumidified through the primary cooling coil, it then passes through a reheat component to deliver comfortable, dehumidified air to the space.

Strategy 2: Passive Dehumidification (low fan speed)

Passive dehumidification is available when a reheat component is not available to operate simultaneously with the cooling coil. The supply fan will slow down to further dehumidify the air stream while still meeting the space cooling set point.

Economizer Control

The economizer control is available in multiple strategies to meet your space's needs, including:

- Outdoor Dry Bulb
- Outdoor Enthalpy
- Comparative Dry Bulb
- Comparative Enthalpy
- Demand-Controlled Ventilation

Energy Recovery Wheel

Factory installed controllers are pre-programmed to optimize energy recovery and prevent frost formation. There is nothing to commission during start up.

- Speed Control: One Speed, One Speed with Rotation Sensing, or Modulating (variable speed with rotation sensing) options.
- Frost Prevention: Timed Defrost, Wheel Speed Frost Prevention, or Pre Heat Frost Prevention option available for colder climates.
- Wheel Capacity Limiting to evaluate if the energy wheel should be operating or if it is more energy efficient to directly bring in outdoor air.

Scheduling

- 7 daily schedules
- 1 holiday schedule (up to 10 days per year)
- Automatically run holiday schedule on set holiday dates
- Network schedule control available when BAS integrated

Split DX / Compressor Control

All units with factory-integrated controllers are capable of automatic compressor, lead-lag control. Lead-lag control is available based on selectable compressor run-time or compressor starts. If automatic control is not desired, the operator can assign fixed lead and lag designations to the compressor circuits.

Timed Occupant Override

When non-scheduled unit operation is desired, initiate timed occupant override by pressing the occupant override button on the integrated thermostat. The unit then starts and runs in override mode for an adjustable length of time (up to five hours). If the button is pressed again while the unit is operating, the timer resets to the full time allowance without interrupting unit operation. Override operation also can be initiated by a BAS.

Auto/Manual Operation Selection

From the integrated thermostat keypad, there are a variety of occupancy and auto/manual control mode selections available to the operator:

Occupancy Modes	Control Modes
Occupied	Off manual
Unoccupied	Auto
Bypass (occupant override)	Heat
Standby	Cool
	Fan Only

Additional Features and End Devices

Run-time Monitoring

- Fan run-time
- Dirty filter notification based on run-time or a field-installed differential pressure switch
- Compressor start count or run-time recording

Startup System Check (Portable Interface Only)

Verify unit operation with two available startup overrides:

- Operational Override - temporarily place the unit in maximum heating or cooling mode
- Output Override - temporarily command specific components to operate

Alarm History

Controller records 30 most recent alarms to help determine patterns and aid troubleshooting.

Duct Static Pressure Control

Duct static pressure control is maintained by a PI algorithm, which provides precise control of the supply fan. The integrated thermostat keypad programmable set point can be set between 0.20-in. W.C. and 4.00-in. W.C.

Internal Time Clock

An internal, battery-backed time clock is included. Current date and time can be quickly and easily set at the portable interface.

Digital-Ready Features (for field-installed controllers)

For units without a factory-integrated controller, there are digital-ready selections available for connecting to an existing BAS and controller in the field.

Fan Speed Control

0-10 VDC Analog Control

Fan modulation control allows the space temperature to be controlled by constantly adjusting the airflow rate across the coil. Increasing and decreasing the CFM across the coil in response to changes in space temperature essentially changes the capacity of the coil to match the current load for improved comfort and reduced energy consumption and unit noise. While fan modulation is typically used with on-off valve control which allows the maximum design GPM through the coil, it may also be used with a modulating control valve to provide even greater temperature control. Fan modulation control requires a controller or thermostat capable of generating and changing the 0-10 VDC signal in response to the changes in space temperature.

3-Speed Discrete Control (Unit Sizes 006-020 Only)

Three speed fan control runs the fan continuously at one of three programmed speeds. These three speeds can be changed on the factory-installed speed adjustment board. This type of control requires a 24 VAC binary signal control signal applied to one of the motors speed terminals. The motor will run at the corresponding speed for as long as the signal is maintained. This type of fan control allows the unit to be controlled with 3 position fan switch or a simple fan coil type thermostat.

Valve Control

Valve modulation controls space temperature by constantly adjusting the water flow rate through the coil to modulate coil capacity and improve comfort.

0-10 VDC Analog Control

The valve actuator responds to a 0-10 VDC input from the controller. As space demand increases and decreases, water flow rates are adjusted as well.

Open/Closed 24 VAC Control

The valve actuator responds to a binary 24 VAC signal. It can be configured for an "on-with-demand" (Normally Closed) or "off-with-demand" (Normally Open) control scheme. The water flow rate is designated by the auto flow valve (circuit setter).

Electric Heat Control

Electric heat control may be binary (on-off) or modulating. With binary the full capacity of the electric heating element turns on with a 24 VAC signal from the controller and stays on until the set point is reached. Modulating control which requires a 0-10 VDC signal from the thermostat or controller uses an SCR switching module to vary the heat output of the electric element. Matching the heat output to space load increases comfort and reduces noise and energy consumption. It is the responsibility of the controls contractor or the customer to ensure that the electric heating elements never operate without the minimum airflow as

listed starting on [page 34](#). Factory provided safety limits built in to the electric heat assembly and the SCR module prevent overheating should a fan failure occur. "[Electric Heat Safety](#)" on [page 65](#) for more information on the operation of the safety limits.

Condensate Overflow

The factory installed overflow switch is a normally closed dry contact that will open when water in the primary drain pan rises to the designated level. The switch must be wired to a controller or thermostat with an appropriate alarm input that will close the cooling valve and possibly turn off the fan when the switch opens. If necessary, the normal state of the dry contact may be changed to normally open by turning the float over on the guide pin. With this change the dry contact will close when water reaches the designated level.

Coil Freeze Protection

If entering air temperatures below 40°F is a possibility, the use of some type of freeze protection is strongly advised. Freeze protection may include adding glycol to the water in the system to prevent coil rupture or using a low temperature thermostat capillary tube mounted on the inlet side of the primary or preheat coil. If glycol is used, the type and amount of glycol should be determined by the application requirements and must be accounted for in the coil performance calculations. A low temperature thermostat capillary tube should be connected to a controller, capable of closing the outside air damper and opening the control valve to allow water flow through the coil. It should also send an alarm to the BAS or maintenance station to alert appropriate personnel.

Damper Control

- Damper control can be factory configured for either on-off or analog control.
- On-off control requires a 24 VAC signal applied to the terminal labeled ACT 24+ to cycle the damper.
- Analog control requires a 0-10 VDC signal applied to the terminal labeled ACT 0-10V to modulate the damper.

Mixing Box (Optional) – Field Provided Damper Actuator

The optional mixing box includes a fresh air and return air damper that are linked together and driven from the same actuator. It may be ordered with or without the factory mounted damper actuator. Those with the factory mounted actuator ship pre-wired to the main unit control box and do not require field adjustment of the hardware or linkage.

For the mixing box ordered without the factory mounted damper actuator one must be provided in the field that meets the following criteria.

- Maximum range of rotation = 95°
- Maximum torque = 62 in/lbs
- On-off control = spring return
- Modulating control = 0-10 VDC fail in place
- Damper shaft size = 0.5" diameter

A mounting plate is provided on the shaft side of the damper frame to accommodate a variety of actuators. However, due to the number of options, size variations, and arrangements available, some actuators may require alternate field provided mounting hardware. Proper support for the actuator is important to avoid putting excess stress on the cabinet, linkage, or damper shafts. The installing contractor is responsible for mounting, and wiring of the actuator and adjustment of the damper linkage.

Optional Mixing Box Damper or Discharge Plenum Loss

For reference, losses are similar to those used in custom openings, however, their coefficients are multipliers of velocity pressure based on opening size. These are multipliers of coil velocity pressure. The intake loss assumes a fully open damper in line with the unit, based on the sudden expansion into the unit of 2× the face area and 20% drag from the blade. The discharge loss assumes the sudden expansion of the fan of 10× then a sudden contraction at the discharge of 3× the face area. Losses from a grille are not taken into account.

$$\text{Intake, intake with damper or discharge plenum loss} = \left(\frac{V \times C}{4005} \right)^2$$

V = velocity through the opening

C:	Straight intake without damper = 0.75
	Turned intake without damper = 1.0
	Straight intake with damper = 1.0
	Turned intake with damper = 1.33
	Straight discharge = 1.5
	Turned discharge = 2

Example:

For a selection at 1000 ft/min, mix box with rear intake and discharge plenum down discharge:

Intake loss is $(1000 \times 1/4005)^2 = 0.062"$

Discharge loss is $(1000 \times 1.5/4005)^2 = 0.140"$

Mounting and Access

The air handler unit must be installed on a flat and level surface (or verify that the unit is level when hanging from the ceiling). Where surface irregularities allow the equipment to distort, shim the appropriate base rails to straighten the unit. Distorted units can cause misfit between sections, cabinet leaks, binding of the doors and access panels and prevent proper draining of drain pans.

Leave adequate space around the unit for piping, coils, and drains. Always have access to at least one side of the unit for regular service and maintenance. Refer to images on the following pages for servicing space requirements. Routine maintenance examples include filter replacement, drain pan inspection/cleaning, and motor bearing lubrication.

Note that compact vertical units are accessed from the front of the unit. If they are ducted, access will require removal of the duct.

On the off chance a component such as an energy recovery wheel fails, space to the side of the unit to allow for full removal will be required.

Provide sufficient space on the controls access side of the unit for filter replacement, drain pan cleaning and coil removal, if necessary.

Leave at least 42" of clearance in front of electrical power devices (starters, VFDs, disconnect switches, and combination devices) mounted behind service panels.

Figure 70: Clearance and Access Requirements for Horizontal Units (Unit Sizes 006-050)

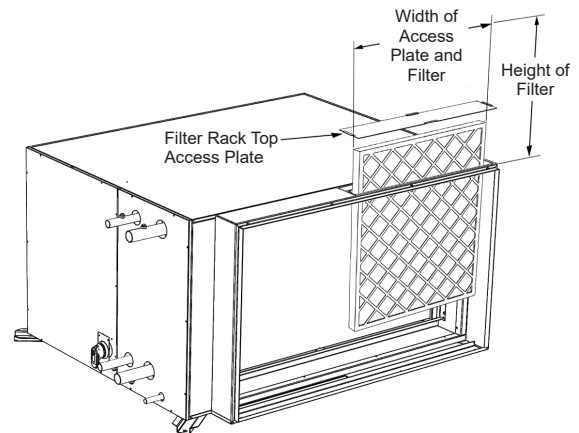
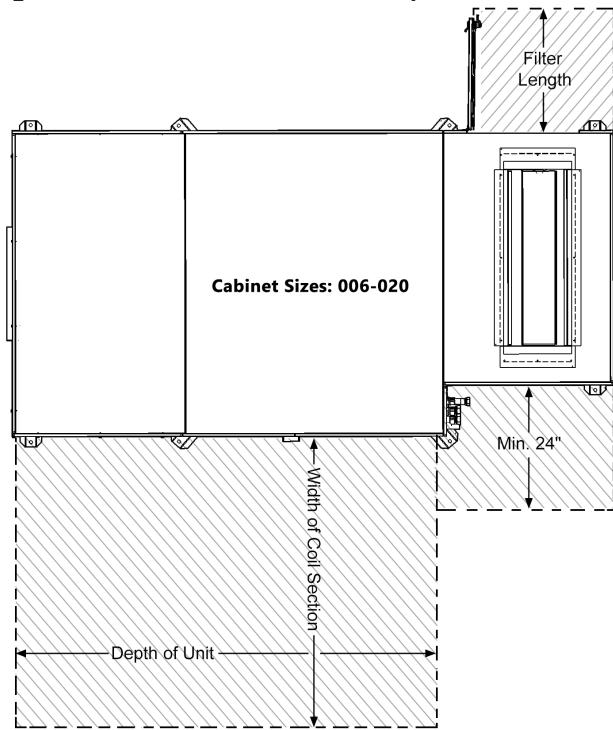

Top Filter Access Clearance Cabinet Sizes: 030 – 050

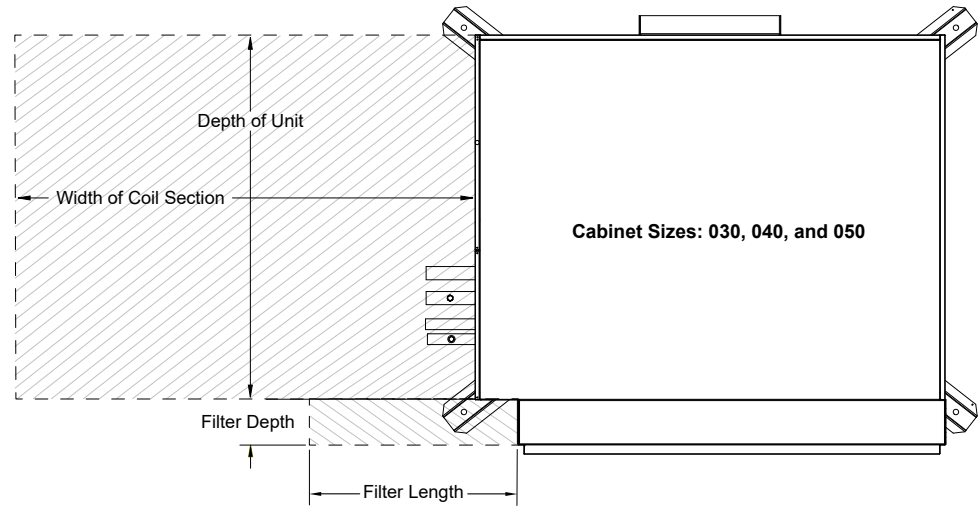
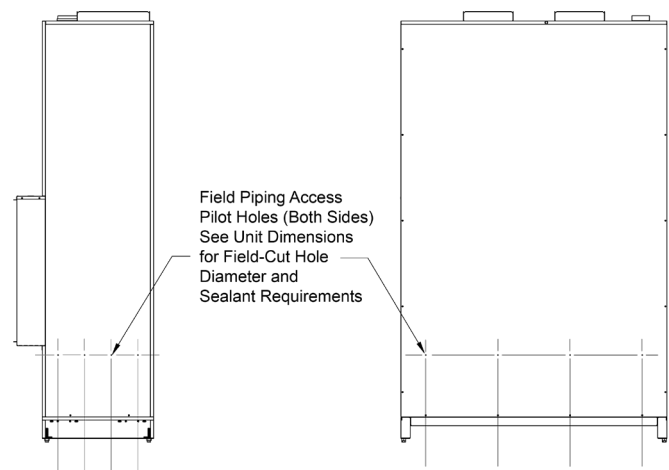
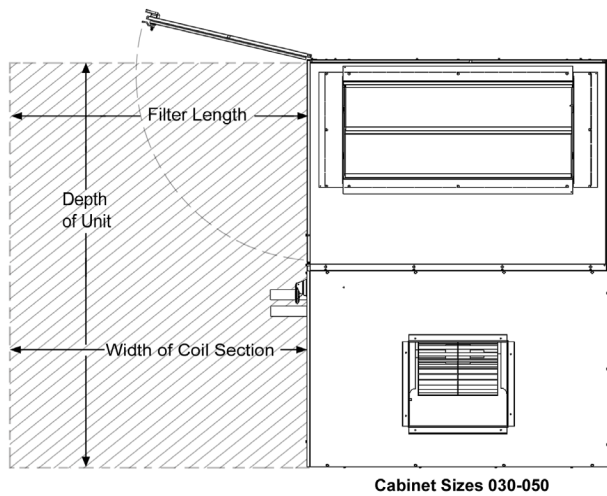
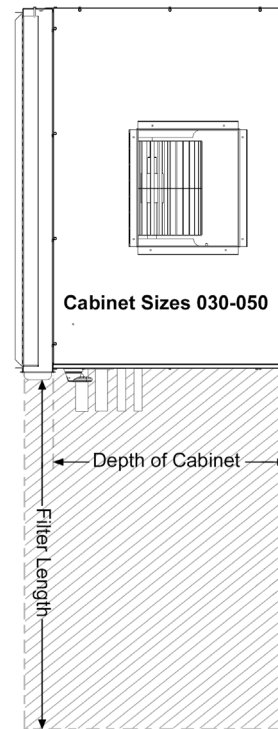
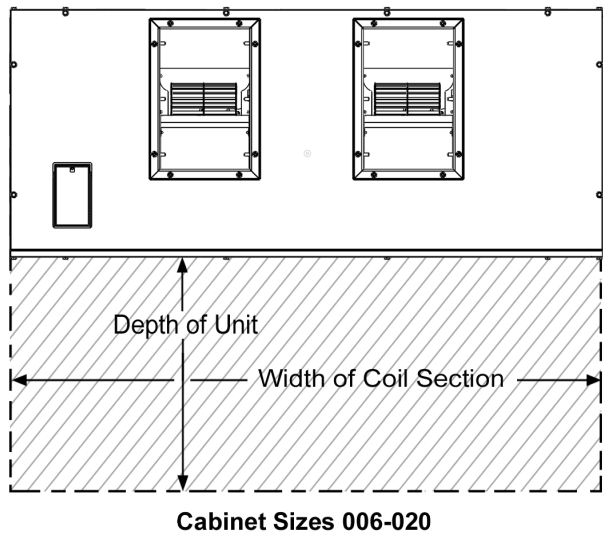

Figure 71: Clearance and Access Requirements for Vertical Units



NOTE: AVD units require field-cut holes on the sides or back, depending on piping orientation. These holes should either be drilled prior to unit installation, or a clearance of 24" should be left on the side requiring field work.

Figure 72: Horizontal Clearance and Access Requirements for Unit Sizes 060-100

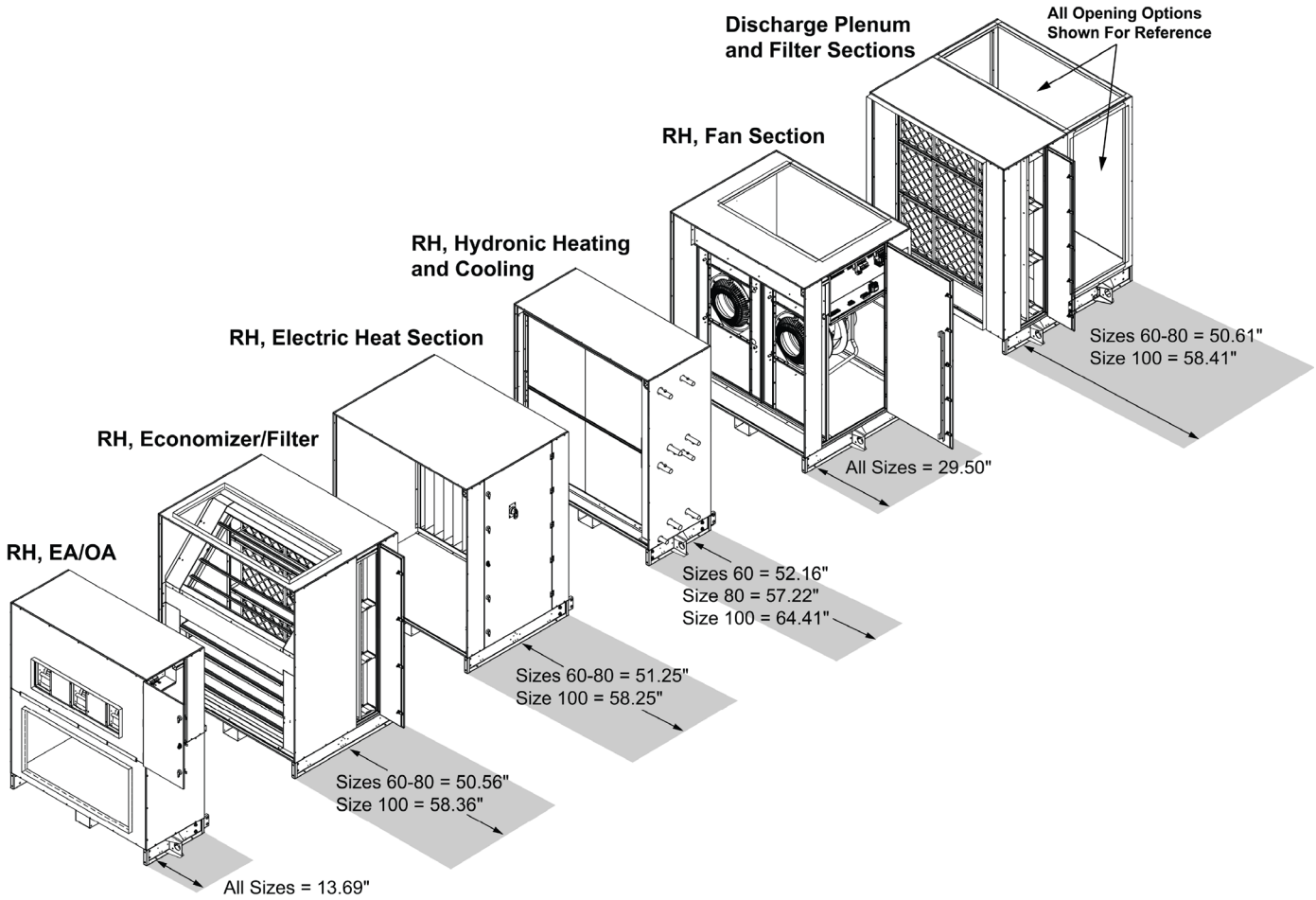

Figure 73: Clearance for Filter Access from Top - Unit Sizes 030-050

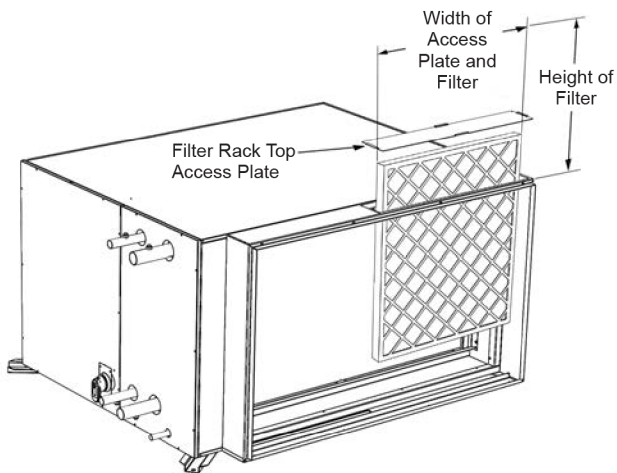
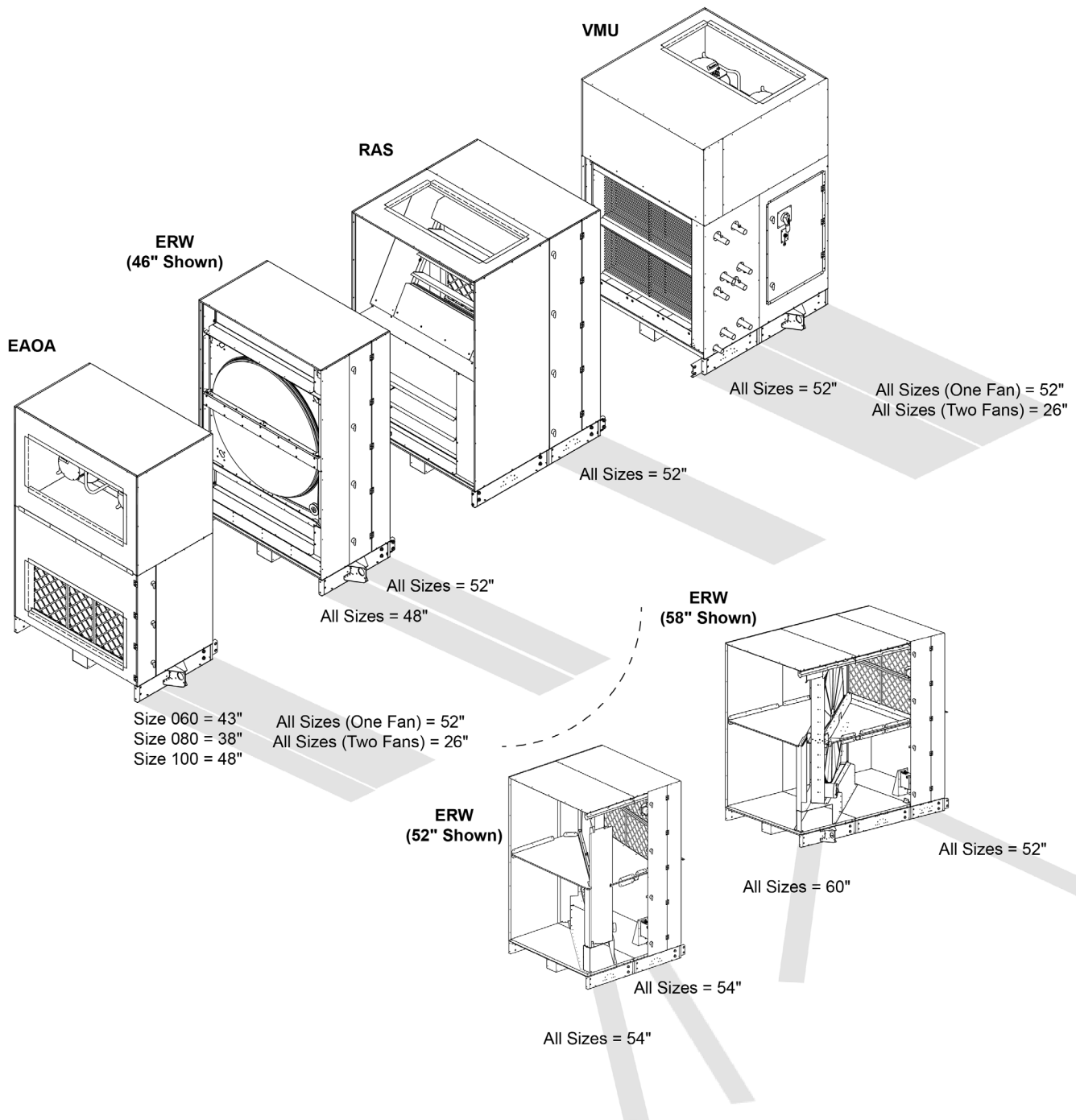

Figure 74: Vertical Clearance and Access Requirements for Unit Sizes 060-100



Horizontal Unit Mounting Isolation

Vibration Isolation (Accessory)

Factory ordered rubber isolators are available for horizontal unit sizes 030-050. Unit sizes 006-020 are internally isolated and do not require external isolation.

Figure 75: Ceiling Hung with Rubber Isolators - Unit Sizes 030-050

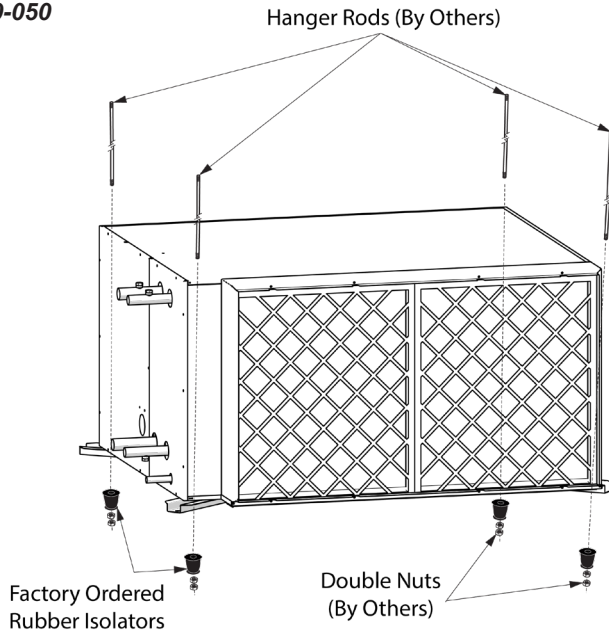

Vertical Unit Mounting Isolation

Neoprene pads and/or spring isolators are to be provided by others, if required.

Figure 76: Size 040 Mounting Rail Holes Detail

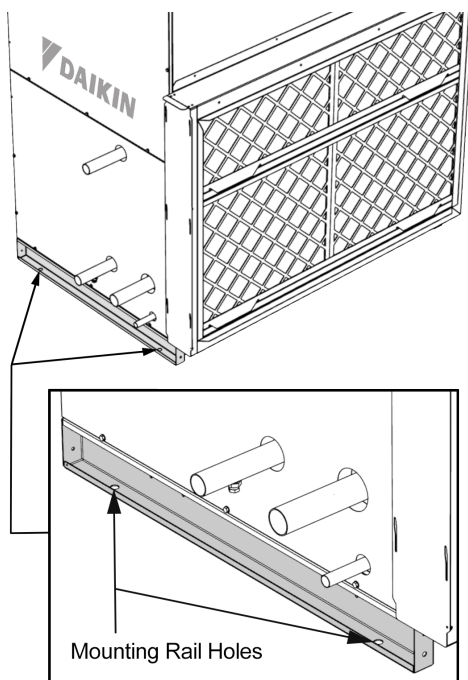

Access Panels and Doors

PreciseLine air handlers have hinged access doors or screw-on panels that can be easily removed and handled. To gain access through a side panel, remove the fasteners along the sides of the panel and lift the panel off. Allow sufficient space for service panel removal and to meet the service clearance requirement of the section it accesses. Service panels are not interchangeable with service panels on the opposite side of the unit.

Figure 77: Panel Removal

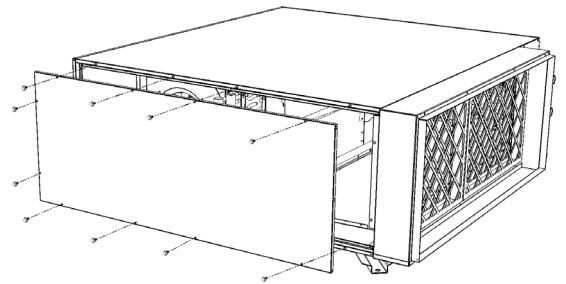

Figure 78: Filter Access Doors

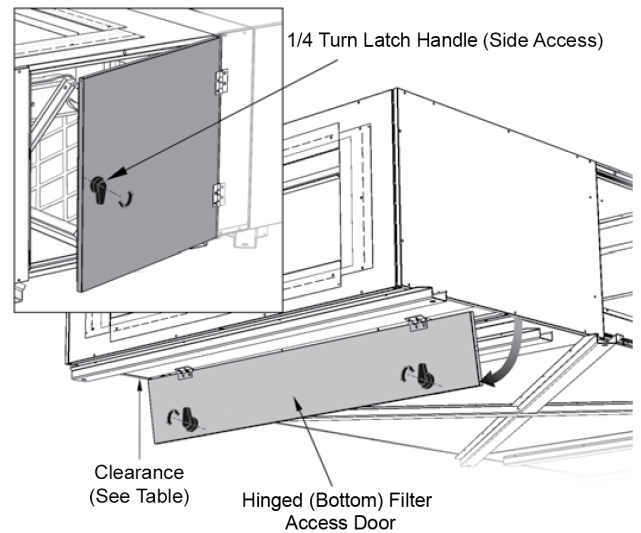
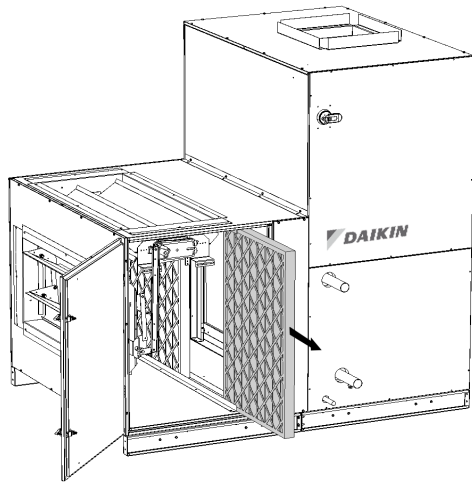

Table 102: Bottom Filter Access Clearance

Unit Size	006 – 020	030	040	050
Clearance	18 in	24 in	28 in	30 in

Figure 79: Filter Access Doors



Piping and Coils

Follow applicable piping design, sizing, and installation information presented in ASHRAE Handbooks in the design and installation of piping. Observe all local codes and industry standards. Piping field connection locations are the same for units with and without the optional factory-installed valve package. Refer to [page 116](#) through [page 118](#) for the connection size and type. Refer to dimensional drawings beginning on [page 67](#) for connection locations and dimensions.

Hydronic Coil Connections

For all unit sizes 030-050; hydronic supply, return, and drain stubs extend through the end panel of the cabinet, with field connections made outside the cabinet. All stubs are labeled on the end panel. A "No Piping" option is available with internal coil stubs. Chilled water supply, return, and drain stubs may terminate inside or outside the cabinet on compact horizontal units, and necessarily terminate in a central location inside the cabinet on AVD units. Stub outs are labeled individually and/or on the end panel.

Hydronic supply and return connections are copper FPT on unit sizes 006 through 020 and copper sweat on unit sizes 030 through 050. Refer to [page 116](#) for connection sizes and type.

Hydronic heating coil guidelines are listed below.

1. Hot water coils are not recommended for use with entering air below 40°F.
2. If fresh air and return air are to be heated by a hot water coil, take care in the design of the system to provide thorough mixing before air enters the coil.

Figure 80: Coil Connections, Unit Sizes 006-020

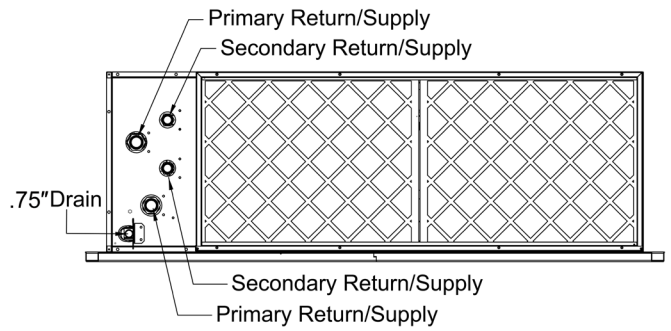

NOTE: Left hand unit shown. Right hand unit connections are the same but opposite.

Figure 81: Field Pipe Connections, Unit Sizes 030, 040, 050 (preheat coil option shown)

IMPORTANT!
If piping turns toward the discharge, the distance before the bend must be a minimum of 48" to leave room to remove the fan motor.

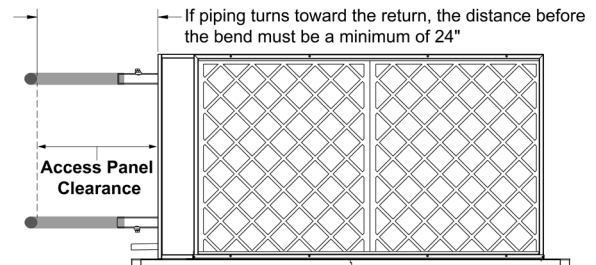
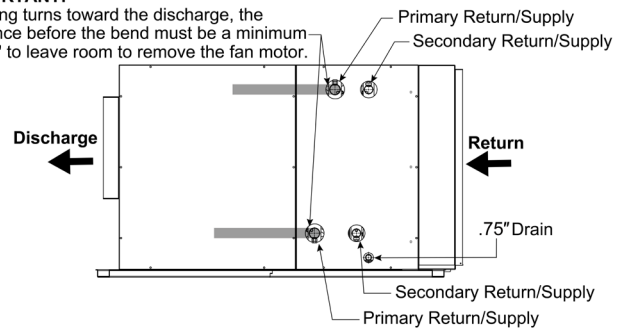

NOTE: Left hand unit shown. Right hand unit connections are the same but opposite.

Figure 82: Coil Connections, Unit Sizes 030-050

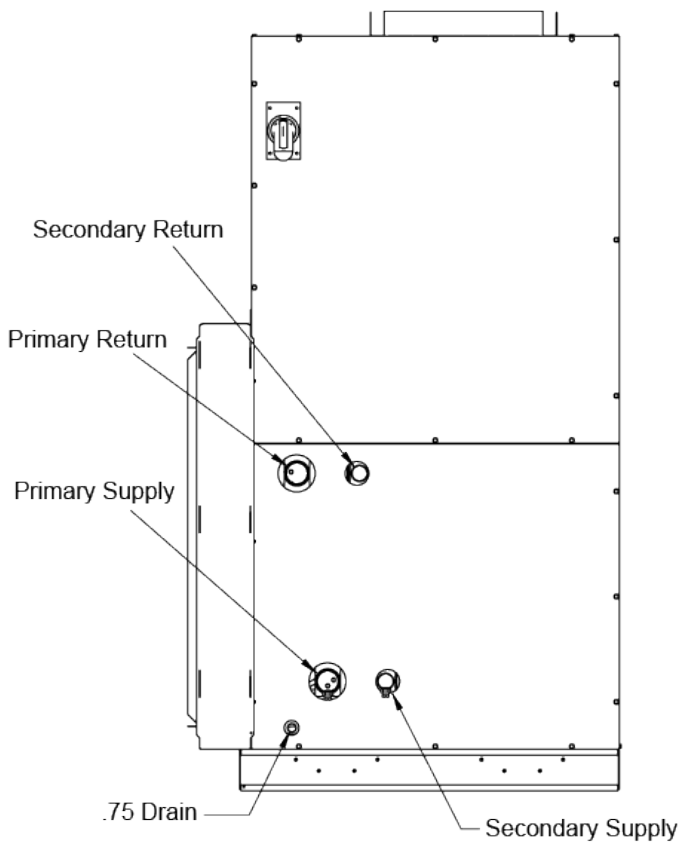

Figure 83: DX Interlaced Coil, Unit Sizes 030-050

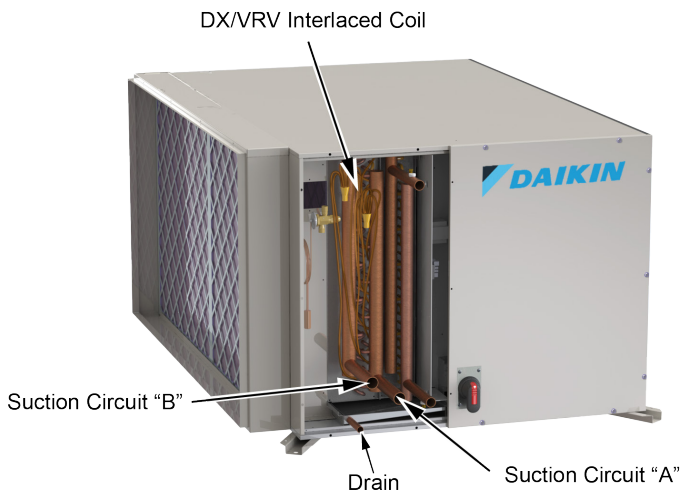
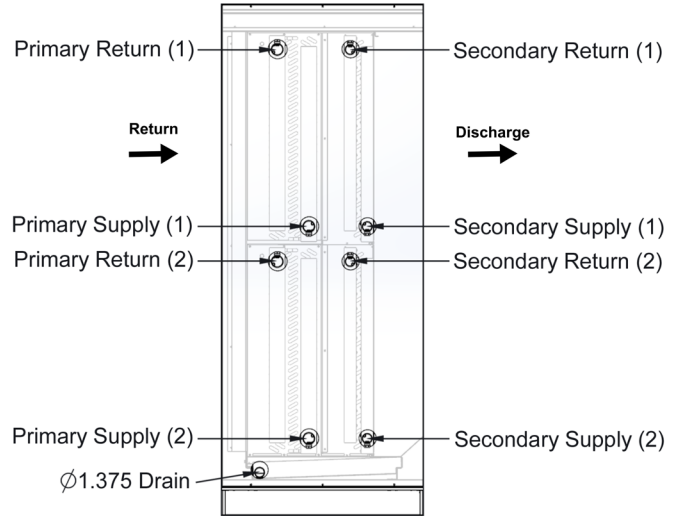

Figure 84: Coil Connections, Unit Sizes 060-100



NOTE: Dimensions shown in inches.

Condensate Drain Pan Traps

Condensate drain stub is .75 O.D. for unit sizes 006-050 and 1.375 O.D. for unit sizes 060-100. Drain lines and traps should run full size from the drain pan stub. Drain pans should have traps to allow condensate from coils to drain freely. The trap depth and distance between the trap outlet and the drain pan outlet should be twice the static pressure in the drain pan section under normal operation for the trap to remain sealed. Refer to Figure 85.

Figure 85: Allow Adequate Distance Between Trap Outlet and Drain Outlet

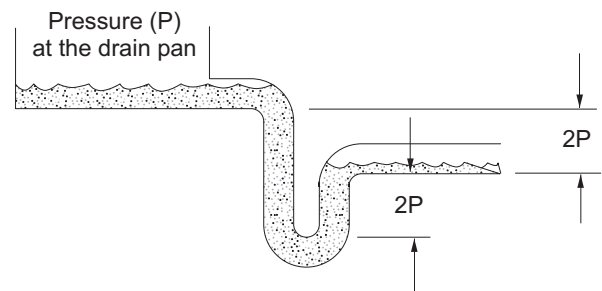
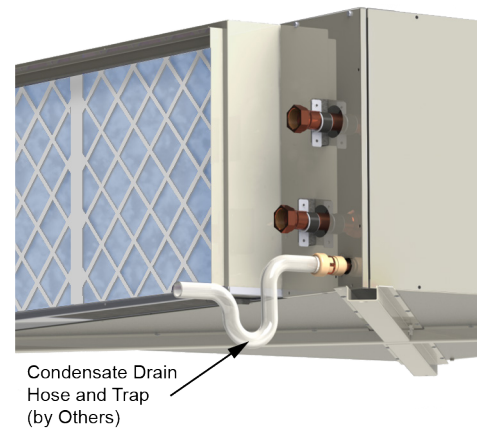

Engineering Specifications

PRECISELINE AIR HANDLERS

PART 1--GENERAL

1.01 SECTION INCLUDES

- A. Horizontal Air Handler
- B. Vertical Air Handler

1.02 REFERENCES

- A. Load ratings and fatigue life for ball bearings.
- B. Standards handbook.
- C. Laboratory methods of testing fans for rating purposes.
- D. Test code for sound rating air moving devices.
- E. Test methods for louver, dampers, and shutters.
- F. Room fan coil unit.
- G. Standard practice for operating salt spray apparatus.
- H. Motors and generators.
- I. National electrical code.
- J. HVAC duct construction standards - metal and flexible.
- K. Test for surface burning characteristics of building materials.
- L. Test performance of air filter units.
- M. Standard for heating and cooling equipment.
- N. Test for flammability of plastic materials for parts in devices and appliances.

1.03 SUBMITTALS

- A. Shop Drawings: Indicate assembly, unit dimensions, weight loading, required clearances, construction details, field connection details, and electrical characteristics and connection requirements.
- B. Product Data:
 1. Provide literature that indicates dimensions, weights, capacities, ratings, fan performance, gauges and finishes of materials, and electrical characteristics and connection requirements.

1.04 OPERATION AND MAINTENANCE DATA

- A. Maintenance Data: Include instructions for filter replacement.

1.05 QUALIFICATIONS

- A. Manufacturer: Company specializing in manufacturing Air Handler products specified in this section must show a minimum five years documented experience and complete catalog data on total product.

1.06 DELIVERY, STORAGE, AND HANDLING

- A. Deliver, store, protect, and handle products to site.
- B. Accept products on site wrapped in protective (cardboard wrap OR weather-resistant wrap). Inspect for damage.
- C. Store in a clean dry place and protect from weather and construction traffic. Handle carefully to avoid damage.

1.07 ENVIRONMENTAL REQUIREMENTS

- A. Do not operate units for any purpose, temporary or permanent, until ductwork is clean, filters are in place, and fan has been test run under observation.

PART 2--PRODUCTS

2.01 MANUFACTURERS

- A. The following manufacturers are approved for use. No substitutions will be permitted.
 1. Daikin Applied – “PreciseLine” air handler is the basis of design, including standard product features and all special features required per plans and specifications.

2.02 FAN COIL TYPE AND ARRANGEMENT

- A. The unit shall be furnished as a draw-through style air handler.
- B. [OPTIONAL] A Primary hydronic cooling coil shall be furnished and factory-installed. OR
[OPTIONAL] (DX OR VRV) cooling coils shall be factory-installed.
 1. The maximum operating pressure should not exceed 500 psig (3447 kPa) for units with R-410A refrigerant OR the maximum operating pressure should not exceed 600 psig (4137 kPa) for units with (R-32 OR R-454B) refrigerant.
- C. A Secondary electric-resistive heater shall be factory-furnished (upstream OR downstream) of the primary coil. Automatic and manual-style thermal cut-out switches shall be furnished and installed by the manufacturer. The switches will disconnect the electric heater at air temperatures unsafe for the unit’s continued operation. OR
[OPTIONAL] A Secondary (preheat OR reheat) hydronic coil located (upstream OR downstream) of the primary coil shall be factory-furnished. Entering water conditions are not to exceed 200°F. OR
[OPTIONAL] A Secondary preheat steam coil located upstream of the primary coil shall be factory-furnished. Operating pressure should not exceed 25 psig (172 kPa).

2.03 GENERAL CONSTRUCTION

- A. The air handling unit shall include a blower, fan housing, coil, and drain-pan enclosed within and mounted to a rigid cabinet. Steel parts exposed to moisture shall be galvanized and insulated to prevent condensation. The complete fan assembly shall be wired via quick connect

electrical contacts and easily removable for service and maintenance.

B. Cabinet

1. Unit will be supplied with 1-inch, double-wall panels. The cabinet is to be thermally isolated through injected foam insulation inside each cabinet. Single wall cabinets with fiberglass insulation exposed in the airstream are not acceptable. Frame channels which allow heat conductance between the inside and outside of the cabinet are not acceptable. Base rails used for unit mounting/hanging are acceptable. Panel shall have a minimum thermal insulation of R-6.5. Foam injected insulation conforms to:
 - a. ASTM C1071 (including C665)
 - b. UL 181 for erosion
 - c. 25/50 rating for flame spread/smoke developed per ASTM E-84, UL 723 and NFPA 90A

2.04 SUPPLY FAN(S)

- A. Supply fans shall be a (DWDI forward-curved type OR welded aluminum airfoil plenum type) fan. Fan assemblies shall be balance tested dynamically by the manufacturer. Manufacturer must ensure maximum fan RPM is below the first critical speed.
 - B. The complete fan assembly, including motor and main drain pan shall be easily removable.
 - C. Fan motor(s) assembly shall be direct-drive style and not include belts, pulleys, or sheaves.
 - D. Fan motor(s) shall be of Direct Current Brushless type or minimum motor efficiency of 85 percent when rated in accordance of NEMA Standard MG 1-2016 at full load conditions.
 - E. Manufacturer's supply fan motor must have means to adjust motor speed for field balancing.
 - F. Units shall be certified in accordance with the Central Station Air Handler certification program that is based on AHRI Standard 430.
 - G. [For forward-curved fan] Must be capable of delivering 1.5" w.g. external static pressure and 3.0" w.g. total static pressure at nominal cabinet CFM.
- OR
- H. [For plenum fan] Welded aluminum airfoil plenum fan must be capable of delivering 5.0" w.g. total static pressure at nominal cabinet CFM.

2.05 EXHAUST FAN(S)

- A. (1 OR 2 OR 3) exhaust fans shall be a (DWDI forward-curved OR backwards curved plenum) type. Fan assemblies shall be balance tested dynamically by the manufacturer. Manufacturer must ensure maximum fan RPM is below the first critical speed.
- B. The complete fan assembly, including motor, shall be easily removable.
- C. Fan motor(s) assembly shall be direct-drive style and not include belts, pulleys, or sheaves.

D. Fan motor(s) shall be of Direct Current Brushless type or minimum motor efficiency of 85 percent when rated in accordance of NEMA Standard MG 1-2016 at full load conditions.

E. Manufacturer's supply fan motor must have means to adjust motor speed for field balancing.

F. [OPTIONAL] The forward curved exhaust fan must be capable of delivering 0.5" w.g. external static pressure at 50% nominal unit airflow. OR

[OPTIONAL] The plenum exhaust fan must be capable of delivering 5" w.g. external static pressure at 100% nominal unit airflow.

2.06 FILTERS

- A. [OPTIONAL] An outside air filter shall be provided. It shall a 2" flat type furnished with (MERV 4 OR MERV 8) deep-pleated panel filters.
- B. Draw-through filter section shall be a (2" OR 4" OR flat OR angle) type furnished with (MERV 8 OR MERV 11 OR MERV 13) deep-pleated panel filters.
- C. [OPTIONAL] A draw-through secondary pre-filter shall be provided. It shall be a 2" flat type furnished with (MERV 4 OR MERV 8 OR MERV 13) deep-pleated panel filters.
- D. [OPTIONAL] Final blow-through filter section shall be a 4" flat type furnished with (MERV 8 OR MERV 13) deep-pleated panel filters.
- E. Filter media shall be UL 900 listed, Class I or Class II.
- F. Filters shall be easily accessible via a door or panel located on the (side OR top OR front OR bottom) of the unit.
- G. [OPTIONAL] The (draw-through OR final) filter shall be of disposable type and rating of (MERV 8 OR MERV 13).

2.07 ELECTRICAL

- A. [For forward-curved fan] Supply fans shall be driven by Electrically Commutated motors that are run-tested in the assembled unit and permanently lubricated. All motors shall have integral thermal overload protection with a maximum ambient operating temperature of 55°C. Motors shall be capable operating at 90 percent of rated voltage on all speed settings. Motors can operate up to 10 percent overvoltage.
- B. [For plenum fan] Supply fans shall be driven by NEMA Premium Efficiency motors that are run-tested in the assembled unit and permanently lubricated. All motors shall have integral thermal overload protection with a maximum ambient operating temperature of 40°C. Motors shall be capable of operating 90 percent of rated voltage on all speed settings. Motors can operate up to 10 percent overvoltage.
- C. Motor wires shall include a quick-disconnect motor plug.
- D. All controls equipment including ECM control module, low voltage transformers, safety switches, disconnects, fusing, and terminal strips must be located inside the main unit cabinet.

2.08 COOLING AND HEATING

A. Cooling Coil

1. Cooling performance shall be as specified on the unit schedule.
2. (Water coil OR Direct expansion OR VRV) fins shall have full drawn collars to provide a continuous surface cover over the entire tube for maximum heat transfer. Seamless copper tubes shall be mechanically expanded into the fins to provide a continuous primary-to-secondary compression bond over the entire finned length for maximum heat transfer rates. Bare copper tubes shall not be visible between fins. Coil casing shall be constructed of (galvanized OR stainless) steel.
3. [For water coils] Water coils shall be provided with headers of seamless copper tubing with intruded tube holes to permit expansion and contraction without creating undue stress or strain. Coil connections shall be (male pipe thread on turbo spiral coils OR female pipe thread OR sweat) with connection size to be determined by manufacturer based upon the most efficient coil circuiting. Vent and drain connections shall be furnished on the coil connection, easily accessible inside the cabinet. Vent connections to be provided at the highest point to assure proper venting. Drain connections shall be provided at the lowest point.
4. [For Direct Expansion coils] Direct Expansion coils shall be provided with a distributor. The return coil connection shall be a sweat connection with size to be determined by manufacturer based upon the most efficient coil circuiting.
5. All steel parts exposed to moisture shall be galvanized.
6. Unit shall include a stainless steel primary drain pan and a (galvanized OR stainless) steel secondary drain pan. The primary drain pan shall be positively sloped in every plane. Primary and secondary drain pans to be insulated with anti-microbial closed-cell insulation. The drain pan shall be designed to ensure no pooling of condensate water per ASHRAE 62.2.
7. [N/A AVD units] Coils shall have stub-outs off of the headers extending through the unit paneling.
8. [For AVD units] Coils shall have stub-outs off the headers that end within the internal cabinet.

B. [OPTIONAL] Heating Coil

1. Heating performance shall be as specified on the unit schedule.
2. (Hot water coil OR Steam coil) fins shall have full drawn collars to provide a continuous surface cover over the entire tube for maximum heat transfer. Seamless copper tubes shall be mechanically expanded into the fins to provide a continuous primary-to-secondary compression bond over the entire finned length for maximum heat transfer rates. Bare copper tubes shall not be visible between fins.
3. Coils shall be provided with headers of seamless copper tubing with intruded tube holes to permit expansion and contraction without creating

undue stress or strain. Coil connections shall be (female pipe thread OR sweat) connections with connection size to be determined by manufacturer based upon the most efficient coil circuiting. Vent and drain connections shall be furnished on the coil connection, external to the cabinet. Vent connections shall be provided at the highest point to ensure proper venting. Drain connections shall be provided at the lowest point.

2.09 [OPTIONAL OR STANDARD ON VERTICAL UNIT SIZES 030-100] DISCHARGE PLENUM

- A. A factory-installed discharge plenum is to be furnished attached to the main unit. This component must be constructed of a similar cabinet paneling to the main unit.
- B. [For vertical unit sizes 030-100] A factory-provided discharge plenum is to be furnished for attachment to the main unit. This component must be constructed of a similar cabinet paneling to the main unit.
- C. Sound-absorbing material will be affixed to the internal walls of the discharge plenum.

2.10 [OPTIONAL ON UNIT SIZES 030-100] ECONOMIZER / MIXING BOX

- A. A factory-installed mixing box for mixing two separate airstreams is to be furnished attached to the main unit. This component must be constructed of a similar cabinet that the main unit is constructed of.
- B. [For unit sizes 060-100] An economizer section shall be provided, controlling return, exhaust, and outdoor air.
- C. Dampers intended for modulating each airstream are to be furnished to cover the openings of the supplied mixing box.
 1. [For unit sizes 060-100] Return and outdoor air dampers shall be controlled independently.
- D. [For unit sizes 060-100] Damper blades shall be of airfoil construction. Dampers shall be AMCA Class 1-A leakage rated.
- E. Damper blades shall be interoperable via linkage shaft. Gear linkage dampers shall not be acceptable.
- F. Damper actuators are to be furnished factory-installed on the mixing box. These actuators are to be controlled via (24 VAC ON/OFF signal OR 0-10V modulating signal) and factory-wired back to the control area within the main cabinet.

2.11 [OPTIONAL ON UNIT SIZES 006-020] VALVE PACKAGES

A. Coils

1. Fan coil units shall be provided with factory-installed valve / piping package(s) available for the (primary coil OR primary and secondary coils). All piping packages shall be factory assembled and tested at 400 psig (2760 kPa) and re-tested for leak when factory soldered to the coil(s) at 300 psig (2100 kPa) Maximum Working Pressure of the piping package shall be 300 psig (2100 kPa).

2. The valve package(s) shall be designed so that any condensation is directed into the secondary drain pan. With the secondary drain pan provided, insulation of the piping package is not required.

B. Type and Components

1. The valve package(s) shall be (Basic OR Deluxe) type and provided with:
 - a. Interconnecting copper piping and shut-off ball valves.
 - b. Connecting supply and return lines to the unit.
 - c. [OPTIONAL] Four-pipe packages shall include a venting valve for the secondary coil.
 - d. [For deluxe package only] An automatic circuit setter. The circuit setter includes a cartridge within the valve body that is sized to allow a specific flow rate through the coil. This valve sets flow through the coil without any action required by a system piping balancer.
 - e. P/T ports to measure the temperature or pressure drop across the valve. This pressure drop can be compared to factory-supplied curves that relate the pressure drop to a specific flow rate.
 - f. Unions on the valve package that allow the coil and valve package to be separated and removed from the unit.
 - g. [For deluxe package only] A 20 mesh strainer on the supply side that is easily removed for cleaning, with a blow-off valve. The strainer shall have a pressure rating of up to 400 psig (2,700 kPa).
 - h. Isolating ball valve on the supply side.
 - i. Two-Way valve body(s) positioned on the return side of the coil. A method to relieve pump head pressure to be employed when two-way systems are selected. OR
Three-Way, mixing-style valve body(s) to be positioned on the return side of the coil.

C. [For deluxe package only] Control

1. The valve package is to be furnished with (two-position On/Off valve actuators OR proportional modulating actuators).
2. The furnished actuators are to be controlled via (24 VAC OR 0-10 VDC) control signal.

2.12 CONTROLS

A. Unit shall be supplied with a digital controls ready interface. This interface is to be located inside the control box internal to the main unit. This interface shall include a 24 VAC transformer and terminal blocks for connections to fan motor control, sensor control, safety switches, valve actuators (and damper control if applicable).

1. [OPTIONAL - Unit sizes 006-020] Fan motor control to be furnished as 0-10VDC. OR
[OPTIONAL] Fan motor control to be furnished as three speed. These three speeds are field adjustable for precise air flow scheduling.

OR

Unit shall be supplied with factory-installed and configured integrated controls.

1. The controller shall control discharge air temperature based on return air temperature, space temperature, or an average of the two.
2. The controller shall allow separate setpoints based on cooling, heating, and dehumidification setpoints for occupied, unoccupied, and standby modes.
3. Controller shall allow for active dehumidification via reheat coil or passive dehumidification via reduced-speed fan operation. Dehumidification shall control via relative humidity or dewpoint setpoint.
4. Sensors shall be provided for space temperature, discharge air temperature, (entering water OR discharge coil temperature), outdoor air temperature, space humidity, duct static pressure, outdoor air humidity, condensate overflow, freeze protection, airflow proving switch, return air temperature, return air humidity, and dirty filter switch.
5. Supply fan shall be controlled to (constant speed OR duct static pressure OR single-zone VAV operation).
6. [OPTIONAL - Unit sizes 060-100] The controller shall be configurable to operate with a CO₂ sensor provided as an accessory, to provide CO₂-based demand control ventilation. The supply fan shall cycle with demand or operate continuously.
7. [OPTIONAL] Exhaust fan shall control to (an offset of supply fan tracking OR a constant speed).
8. [OPTIONAL] Outdoor air damper shall have a programmable minimum opening position.
9. [OPTIONAL] The economizer shall be equipped with Title-24 compliant fault detection and diagnostics. Economizer shall be controlled via (outdoor air temperature OR outdoor enthalpy OR comparative indoor/outdoor temperature OR comparative indoor/outdoor enthalpy). The controller can be field-programmed for optional outdoor air temperature economizer lock-out.
10. The controller shall be factory configured to control 2-pipe/4-pipe heating or cooling, reverse pipe or direct acting via 24 VAC On/Off or (0-10 OR 2-10) modulating valve control. Entering water temperature sampling for 2-pipe changeover configurations.
11. [OPTIONAL] The controller shall be factory configured to control (1-stage OR 4-stage OR SCR) electric heat.
12. The controller shall feature a startup test operation mode in which setpoints may be set outside of standard operation to confirm component operation.
13. The controller shall provide run-time totalization for filter, supply fan, exhaust fan, compressor startup totalization and runtime, and compressor runtime control.
14. [OPTIONAL] Controller shall provide dirty filter notification based on fan time or differential filter pressure switch.
15. Controller shall have a 30-event alarm history available to support field troubleshooting.

16. The controller shall have an internal time clock with 7-day programmable schedule.
17. [OPTIONAL] Controller shall allow configurable compressor on/off times as well as configurable controller interstage time and PID loop for 4-stage compressors and discharge air temperature control.
18. [OPTIONAL] The controller shall be factory configured to control the Energy Recovery Wheel.
19. Network communication shall enable read/write functionality of control points, including space temperature, CO2 value, space relative humidity, entering water, fan speed, outdoor air temp, OA relative humidity, network enabling/disabling of economizer/cooling/heating/dehumidification.

B. [OPTIONAL] Unit shall be furnished with a disconnect switch and 65 KAIC inline fusing to protect vital electrical components. The disconnect switch shall be operable from the outside of the cabinet to reduce hazards during field service and commissioning.

C. [For DX units with R-32 or R-454B refrigerants] Unit shall be supplied with an enclosed leak refrigerant detection system (RDS).

2.13 [OPTIONAL ON VERTICAL UNIT SIZES 060-100] DEFROST HEATER

- A. Heating performance shall be as specified on the unit schedule.
- B. Hot Water Defrost
 1. The unit shall be provided with a Hot Water defrost heater to prevent frost on (the energy recovery device OR the coils).
 2. Hot water coil fins shall have full drawn collars to provide a continuous surface cover over the entire tube for maximum heat transfer. Seamless copper tubes shall be mechanically expanded into the fins to provide a continuous primary-to-secondary compression bond over the entire finned length for maximum heat transfer rates. Bare copper tubes shall not be visible between fins.
 3. Coils shall be provided with headers of seamless copper tubing with intruded tube holes to permit expansion and contraction without creating undue stress or strain. Coil connections shall be sweat connections with connection size to be determined by manufacturer based upon the most efficient coil circuiting. Vent and drain connections shall be furnished on the coil connection, external to the cabinet. Vent connections shall be provided at the highest point to ensure proper venting. Drain connections shall be provided at the lowest point.

OR

Electric Heat Defrost

1. An electric preheat coil with (1-Stage OR SCR) control shall be provided to prevent frost on the (energy recovery device OR coils).
2. Electric heating coils shall be UL listed, open-wire resistance heaters. Heating coils shall

be constructed of high nickel-chromium alloy resistance wire (80% Ni/20% Cr).

3. A separate power connection shall be used for the electric heater.

2.14 [OPTIONAL - VERTICAL UNIT SIZES 060-100] ENERGY RECOVERY

A. The unit shall be provided with an AHRI certified rotary wheel air-to-air heat exchanger in a cassette frame complete with seals, drive motor and drive belt. The energy recovery wheel shall be an integral part of the unit with unitary construction, power supply and controls and does not require field assembly. Bolt-on energy recovery units that require field assembly and section to section gasketing and sealing are not acceptable.

B. The energy recovery wheels supplied must meet the scheduled capacity and air pressure drop.

C. The wheel capacity, air pressure drop and effectiveness shall be AHRI certified per AHRI Standard 1060.

D. [OPTIONAL] The unit shall have an energy wheel temperature sensor that measures entering air temperature and leaving air temperature.

E. The unit shall be designed with a track so the entire energy recovery wheel cassette can slide out from the unit to facilitate cleaning.

F. The unit shall have 2" (Merv 8 OR Merv 4) filters for the return air before the wheel to help keep the wheel clean and reduce maintenance.

1. [OPTIONAL] A dirty filter switch and alarm shall be provided on the energy wheel filter rack.

G. The total energy recovery wheel shall have a polymer substrate bonded permanently with desiccant.

H. A (0-10V VFD OR Modbus Communication) shall be provided for wheel capacity and frost prevention control by the unit controller.

I. [OPTIONAL ON 46" ERW OR STANDARD ON 52 OR 58" ERW] The energy recovery wheel shall have a bypass damper.

2.15 [OPTIONAL ON VERTICAL UNIT SIZES 060-100] POST ELECTRIC HEAT

A. Post electric heat shall require field assembly.

B. Post electric heat with (4 stage OR SCR) control shall be provided.

C. Electric heating coils shall be UL listed, open-wire resistance heaters. Heating coils shall be constructed of high nickel-chromium alloy resistance wire (80% Ni/20% Cr).

D. A separate power connection shall be used for the electric heater.

COMPLETE HVAC SYSTEM SOLUTIONS

SELF-CONTAINED | ROOFTOPS | COILS | CONDENSING UNITS
AIR HANDLERS | WATER-COOLED CHILLERS | AIR-COOLED CHILLERS
MODULAR CENTRAL PLANTS | SITELINE BUILDING CONTROLS
UNIT HEATERS | FAN COILS | AIR PURIFIERS | WATER SOURCE HEAT PUMPS
VARIABLE AIR VOLUME UNITS | UNIT VENTILATORS



13600 INDUSTRIAL PARK BLVD. | MINNEAPOLIS, MN 55441
1-800-432-1342 | 763-553-5330

LEARN MORE AT
DAIKINAPPLIED.COM