

# AIR TERMINAL UNITS

Models MQTH, MQFCI, and MQFVI



**Model MQTH**



**Model MQFCI**

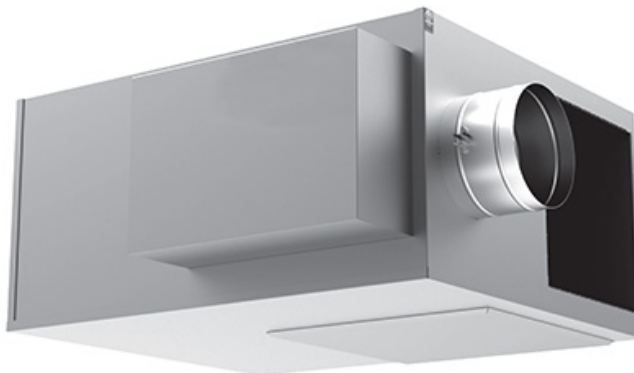

**Model MQFVI**

<b>Introduction</b> . . . . .	<b>3</b>	<b>Performance Data</b> . . . . .	<b>53</b>
Single Duct Air Terminal Units - MQTH-500 . . . . .	3	MQFVI-500 AHRI Certified Rating Points . . . . .	53
<b>Components and Technology</b> . . . . .	<b>4</b>	Hot Water Coils . . . . .	69
Standard Features . . . . .	4	Electric Heat . . . . .	70
<b>Dimensional Data</b> . . . . .	<b>5</b>	<b>Options and Accessories</b> . . . . .	<b>72</b>
MQTH-500 Single Duct Air Terminal Unit . . . . .	5	Control Enclosures . . . . .	72
<b>Performance Data</b> . . . . .	<b>10</b>	Filters . . . . .	72
MQTH-500 AHRI Certified Rating Points . . . . .	10	Handing . . . . .	72
<b>Accessories and Components</b> . . . . .	<b>24</b>	Construction Options . . . . .	72
Hot Water Coils . . . . .	24	Insulation . . . . .	73
Electric Heat . . . . .	24	Access Options . . . . .	73
<b>Introduction</b> . . . . .	<b>26</b>	Inlet Flow Sensors . . . . .	74
Fan Powered Terminal Units . . . . .	26	Primary Air Dampers . . . . .	76
Series Fan Powered Terminal Units - MQFCI-600 . . . . .	28	Hot Water Coils . . . . .	76
<b>Components and Technology</b> . . . . .	<b>29</b>	Electric Heat . . . . .	77
<b>Dimensional Data</b> . . . . .	<b>30</b>	Electric Heat – Typical Wiring Diagrams . . . . .	79
MQFCI-600 Series Fan Powered Air Terminal Unit . . . . .	30	Electronically Commutated Motors . . . . .	83
<b>Performance Data</b> . . . . .	<b>33</b>	Controls . . . . .	84
MQFCI-600 AHRI Certified Rating Points . . . . .	33	<b>System Considerations</b> . . . . .	<b>85</b>
Hot Water Coils . . . . .	44	UL 1995 and Daikin Applied Electric Heat	
Electric Heat . . . . .	45	Design Criteria . . . . .	85
Parallel Fan Powered Terminal Units - MQFVI-500		Sound Path Attenuation Assumptions . . . . .	86
Variable Volume . . . . .	47	System Design and Noise Generation . . . . .	87
<b>Components and Technology</b> . . . . .	<b>48</b>	<b>Engineering Specifications</b> . . . . .	<b>88</b>
<b>Dimensional Data</b> . . . . .	<b>49</b>		



**Hazard Identification**

<b>DANGER</b>
Danger indicates a hazardous situation, which will result in death or serious injury if not avoided.

<b>WARNING</b>
Warning indicates a potentially hazardous situations, which can result in property damage, personal injury, or death if not avoided.

<b>CAUTION</b>
Caution indicates a potentially hazardous situations, which can result in minor injury or equipment damage if not avoided.

<b>NOTICE</b>
Notice indicates practices not related to physical injury.

**NOTE:** Indicates important details or clarifying statements for information presented.

©2026 Daikin Applied, Minneapolis, MN. All rights reserved throughout the world. This document contains the most current product information as of this printing. Daikin Applied Americas Inc. has the right to change the information, design, and construction of the product represented within the document without prior notice. For the most up-to-date product information, please go to [www.DaikinApplied.com](http://www.DaikinApplied.com).  
 ™ MicroTech and Daikin Applied are trademarks or registered trademarks of Daikin Applied Americas Inc. The following are trademarks or registered trademarks of their respective companies: BACnet from American Society of Heating, Refrigerating and Air-Conditioning Engineers, Inc.; Echelon, LonWorks, LonMark, and LonTalk from Echelon Corporation; Modbus from Schneider Electric; and Windows from Microsoft Corporation.

# Introduction

## Single Duct Air Terminal Units - MQTH-500

The Daikin Applied single duct terminal units are at the core of today's variable air volume (VAV) systems. The staple of today's HVAC system designer, VAV systems lower operating costs by using less central fan energy and less refrigeration energy. VAV systems also have lower first costs by allowing the designer to take advantage of the building's diversity.

The primary function of the Daikin Applied single duct terminal units is to regulate conditioned air flow into an occupied zone in response to a control signal. Daikin Applied single duct terminal units can be applied in both pressure-dependent and pressure-independent applications in duct systems with static pressures up to 3.0 in.w.g.

With the demands of today's building designs to reduce energy in smaller mechanical spaces, the Daikin Applied single duct terminal unit is the perfect choice.

The Daikin Applied MQTH-500 is the simplest and most widely used VAV terminal unit. Its basic components are an insulated

sheet metal box, round inlet damper, flow measuring device and rectangular outlet. The unit is served by a central air handler and modulates the amount of 'primary' cooling air to the space between a minimum set point and the design airflow.

When necessary, the Daikin Applied MQTH-500 can be provided with a heating coil on the discharge of the unit to provide for reheat.



Figure 1: MQTH-500 Nomenclature

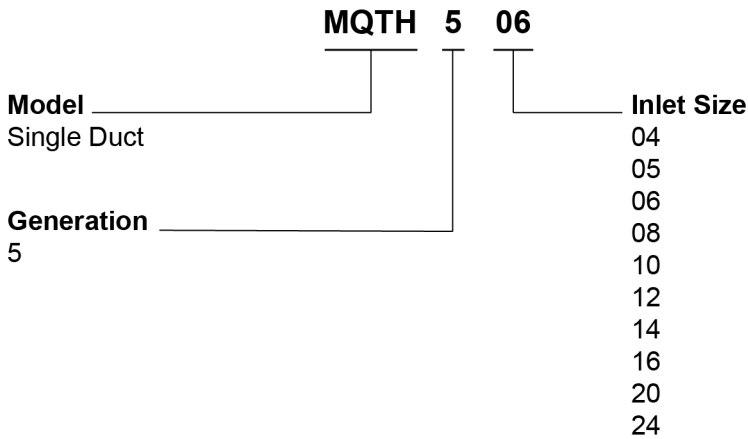

# Components and Technology

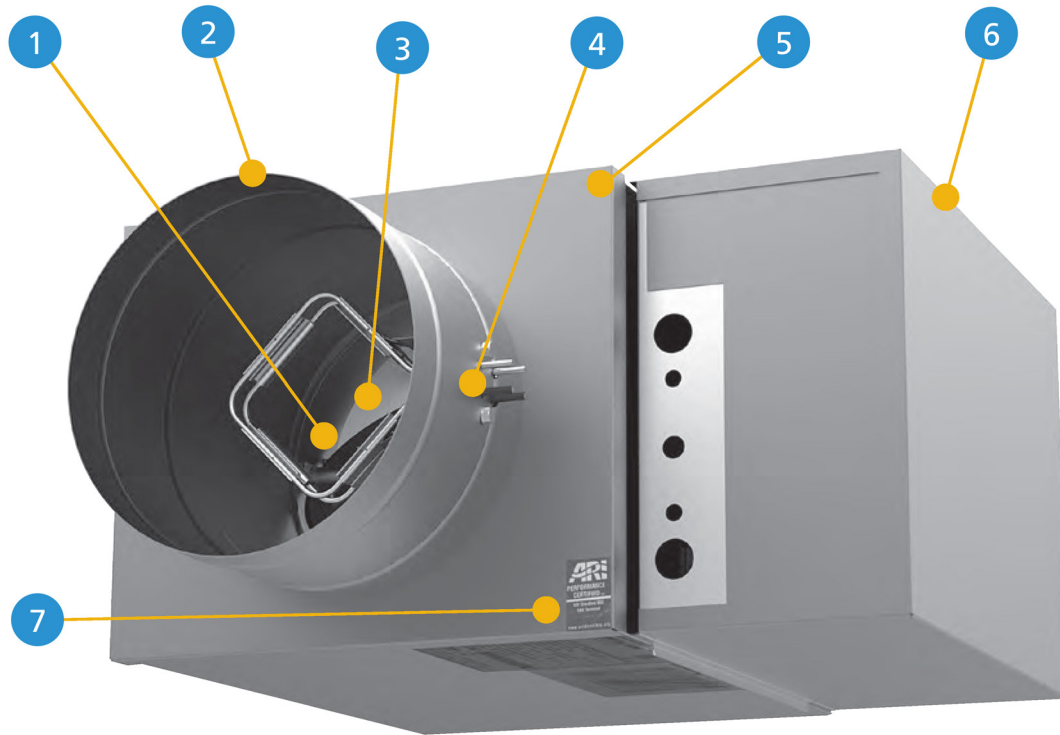

No.	Component	Description
1	Low Friction Bearing	Damper rotates in a self-lubricating, long life, low friction thermoplastic bearing
2	Continuous Welds	Continuous welded primary inlet duct to minimize leakage with three stiffening beads for added rigidity
3	Heavy-Duty Construction	Damper construction of double layer 18 gauge equivalent with mechanically fastened integral blade seal
4	Multi-Quadrant Averaging Flow Sensor	All metal constructed inlet flow sensor with extra balancing taps
5	Galvanized Steel Casing	Galvanized steel casing, mechanically sealed for low leakage construction
6	NEMA 1 Control Enclosure	NEMA 1 rated control enclosure with stand-off to prevent penetration of casing standard on all terminal units
7	AHRI Certified	All MQTH-500 terminal units are AHRI certified and shipped with the AHRI seal

## Standard Features

- MQTH-500 available in 10 unit sizes
- Variable or constant volume applications
- 22 ga. galvanized steel casing, mechanically sealed for low leakage
- Damper construction of double layer, 18 gauge equivalent, galvanized steel with sandwiched flexible gasket, mechanically fastened to provide tight seal (<1% at 3.0 in.w.g. static pressure)
- Optional factory calibrated controls to meet all control strategies
- Multi-quadrant, averaging flow sensor for highly accurate (+/-5%) flow readings with varying inlet duct configurations after certified balancer has balanced terminal
- Externally accessible steel balancing taps
- External control cabinet with offset mounting plate is standard
- 3-beaded inlet connection tube for added rigidity and secure flex duct connections
- 1/2" thick, dual density (1.5 lbs/ft<sup>3</sup> min.) fiberglass insulation with edges coated. Meets NFPA 90A and UL 181
- Rectangular discharge with slip and drive cleat duct connection
- Independently tested and certified laboratory performance data
- Full range of options and accessories available (heating coils, disconnects, attenuators, etc.)
- Full range of liners/insulation available

# Dimensional Data

## MQTH-500 Single Duct Air Terminal Unit

Figure 2: MQTH-500 Single Duct Air Terminal Unit, Cooling Only

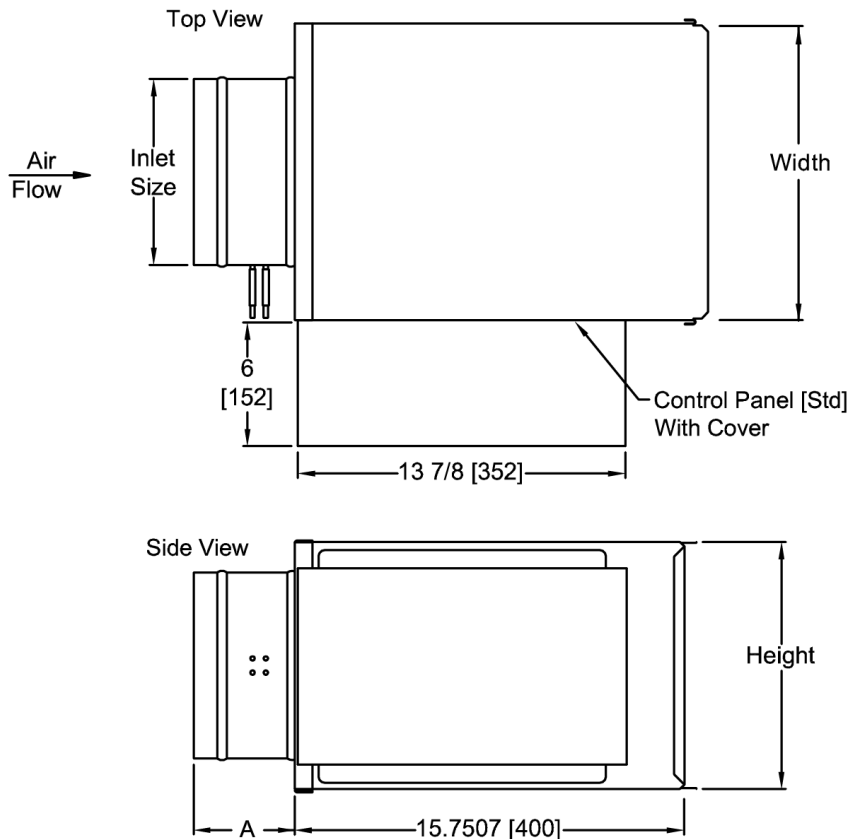

The standard location for control panel is Right Hand on Model MQTH.  
 Looking in the direction of airflow, the control panel is on the right.

The control panel will overhang the top and bottom of model MQTH506 1" (25.4 mm).  
 Control Panel Mounting Surface width by height is 13-7/8" × 9-3/4".

Table 1: MQTH-500 Single Duct Air Terminal Unit, Cooling Only—Unit Dimensions, in (mm) and Weights, lb (kg)

Model Number	Inlet Size	A	Width	Height	Unit Weight, lb (kg)
MQTH504	3-7/8 (99)	5 (127)	12 (305)	8 (203)	12 (5)
MQTH505	4-7/8 (124)	5 (127)	12 (305)	8 (203)	12 (5)
MQTH506	5-7/8 (149)	5 (127)	12 (305)	8 (203)	12 (5)
MQTH508	7-7/8 (200)	5 (127)	12 (305)	10 (254)	15 (7)
MQTH510	9-7/8 (251)	5 (127)	14 (356)	12-1/2 (318)	18 (8)
MQTH512	11-7/8 (302)	5 (127)	16 (406)	15 (381)	22 (10)
MQTH514	13-7/8 (353)	5 (127)	20 (508)	17-1/2 (445)	24 (11)
MQTH516	15-7/8 (403)	5 (127)	24 (610)	18 (457)	29 (13)
MQTH520	19-7/8×15-7/8 (505×403)	6 (152)	30 (762)	20 (508)	47 (21)
MQTH524	23-7/8×15-7/8 (607×403)	6 (152)	38 (965)	20 (508)	58 (26)

Figure 3: MQTH-500 Single Duct Air Terminal Unit with Hot Water Coil

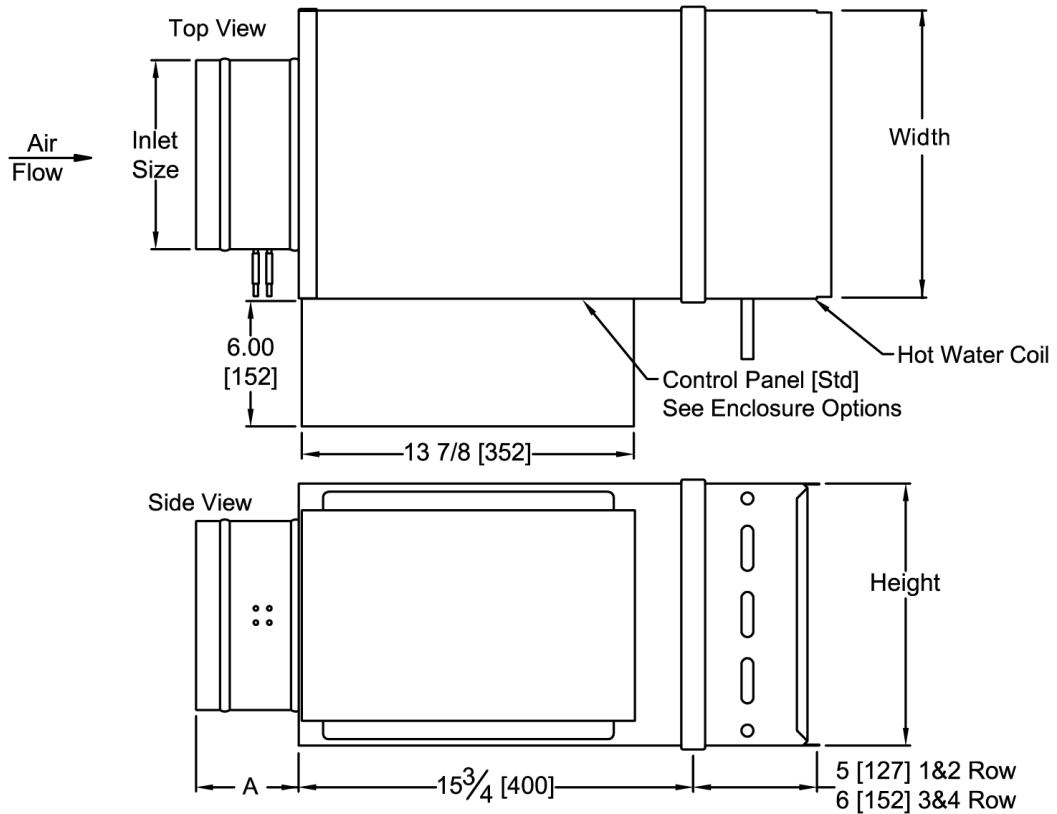

The standard location for control panel is Right Hand on Model MQTH.  
Looking in the direction of airflow, the control panel is on the right.

The control panel will overhang the top and bottom of model MQTH506 1" (25.4 mm)  
Control Panel Mounting Surface width by height is 13-7/8" × 9-3/4".

Table 2: MQTH-500 Single Duct Air Terminal Unit with Hot Water Coil—Unit Dimensions, in (mm) and Weights, lb (kg)

Model Number	Inlet Size	A	Width	Height	Unit Weight, lb (kg)			
					1 Row	2 Row	3 Row	4 Row
MQTH504	3-7/8 (99)	5 (127)	12 (305)	8 (203)	17 (7.7)	18 (8)	24 (11)	23 (10.4)
MQTH505	4-7/8 (124)	5 (127)	12 (305)	8 (203)	17 (7.7)	18 (8)	24 (11)	23 (10.4)
MQTH506	5-7/8 (149)	5 (127)	12 (305)	8 (203)	17 (7.7)	18 (8)	24 (11)	23 (10.4)
MQTH508	7-7/8 (200)	5 (127)	12 (305)	10 (254)	20 (9)	22 (10)	28 (13)	28 (13)
MQTH510	9-7/8 (251)	5 (127)	14 (356)	12-1/2 (318)	24 (11)	27 (12)	34 (15)	38 (17)
MQTH512	11-7/8 (302)	5 (127)	16 (406)	15 (381)	31 (14)	34 (15.4)	41 (19)	43 (19.5)
MQTH514	13-7/8 (353)	5 (127)	20 (508)	17-1/2 (445)	34 (15.4)	39 (17.7)	47 (21)	53 (24)
MQTH516	15-7/8 (403)	5 (127)	24 (610)	18 (457)	42 (19)	48 (21.8)	54 (25)	59 (26.8)
MQTH520	19-7/8×15-7/8 (505×403)	6 (152)	30 (762)	20 (508)	64 (29)	72 (32.7)	77 (35)	86 (39)
MQTH524	23-7/8×15-7/8 (607×403)	6 (152)	38 (965)	20 (508)	79 (36)	89 (40)	93 (42)	109 (49)

Figure 4: MQTH-500 Single Duct Air Terminal Unit with Electric Heat

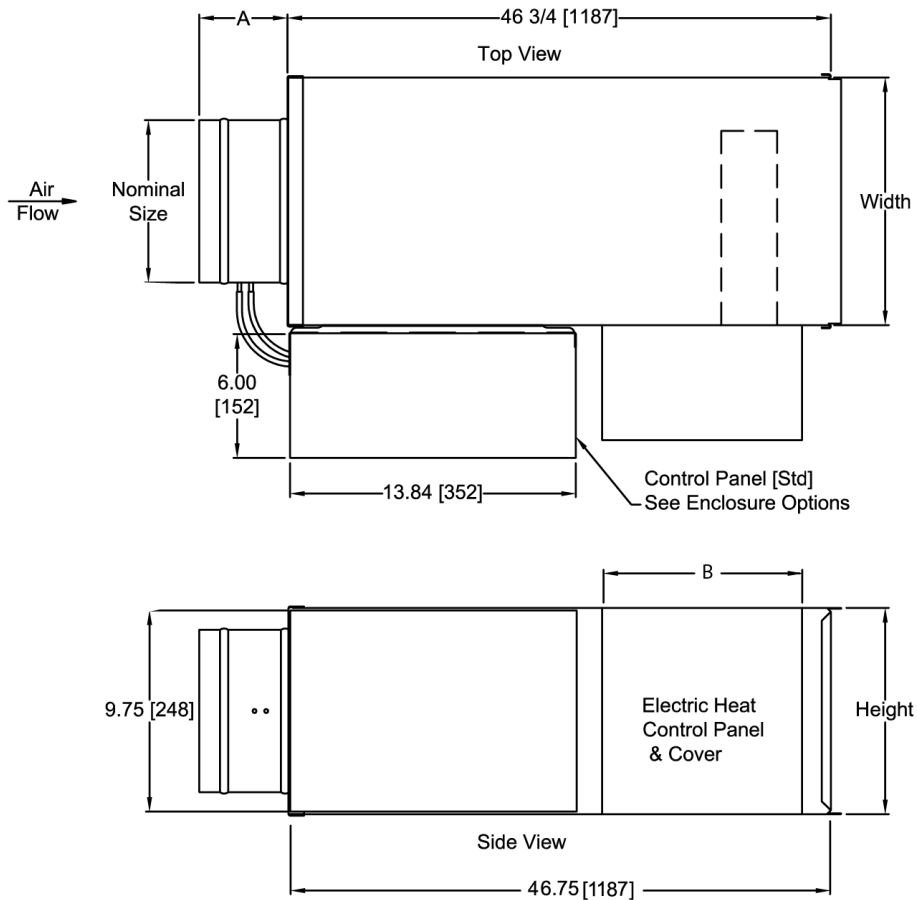

The standard location for control panel is Right Hand on Model MQTH.  
Looking in the primary inlet, the control panel is on the right.

The control panel will overhang the top and bottom of model MQTH506 1" (25.4 mm).  
Control Panel Mounting Surface width by height is 13-7/8" × 9-3/4".

Table 3: MQTH-500 Single Duct Air Terminal Unit with Electric Heat—Unit Dimensions, in (mm) and Weights, lb (kg)

Model Number	Inlet Size	A	B	Width	Height	Unit Weight
MQTH504	3-7/8 (99)	5 (127)	28 (711)	12 (305)	8 (203)	38 (17)
MQTH505	4-7/8 (124)	5 (127)	28 (711)	12 (305)	8 (203)	38 (17)
MQTH506	5-7/8 (149)	5 (127)	28 (711)	12 (305)	8 (203)	38 (17)
MQTH508	7-7/8 (200)	5 (127)	28 (711)	12 (305)	10 (254)	43 (20)
MQTH510	9-7/8 (251)	5 (127)	28 (711)	14 (356)	12-1/2 (318)	50 (23)
MQTH512	11-7/8 (302)	5 (127)	26 (640)	16 (406)	15 (381)	59 (27)
MQTH514	13-7/8 (353)	5 (127)	26 (640)	20 (508)	17-1/2 (445)	67 (30)
MQTH516	15-7/8 (403)	5 (127)	26 (640)	24 (610)	18 (457)	77 (35)
MQTH520	19-7/8×15-7/8 (505×403)	6 (152)	22 (559)	30 (762)	20 (508)	103 (47)
MQTH524	23-7/8×15-7/8 (607×403)	6 (152)	22 (559)	38 (965)	20 (508)	122 (55)

Figure 5: MQTH-500 Single Duct Air Terminal Unit with Integral Attenuator

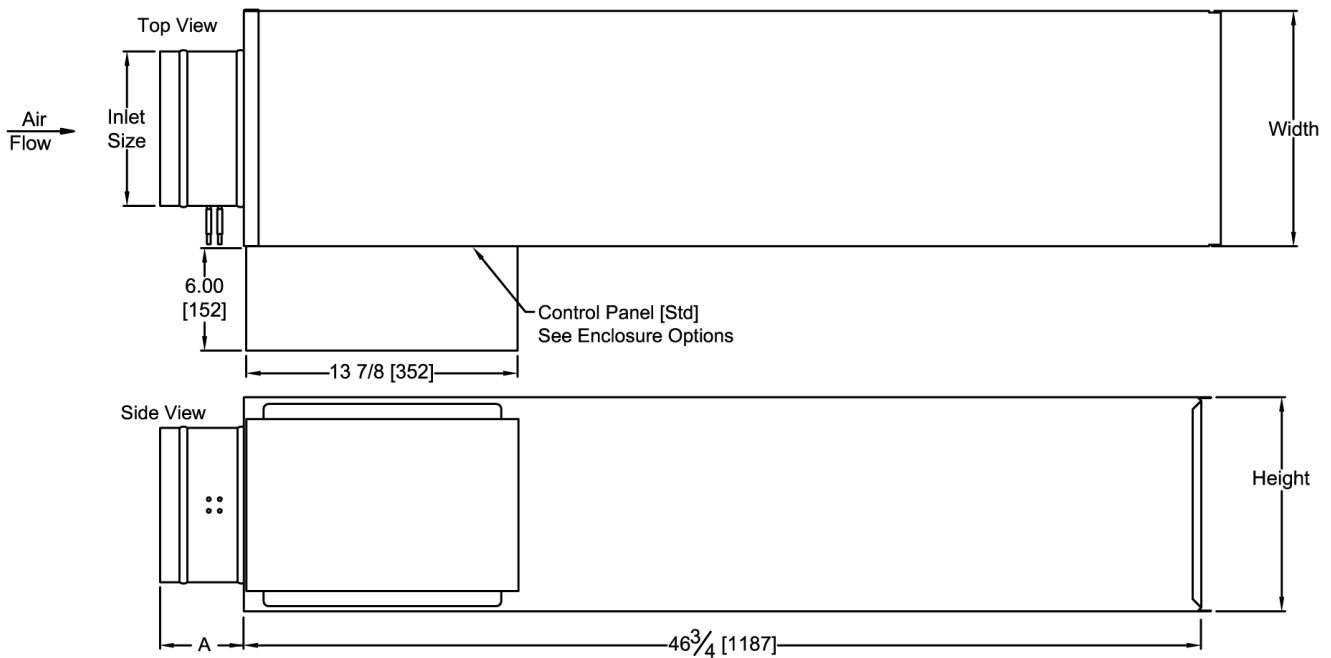

The standard location for control panel is Right Hand on Model MQTH.

Looking in the direction of airflow, the control panel is on the right.

The control panel will overhang the top and bottom of model MQTH506 1" (25.4 mm).

Control Panel Mounting Surface width by height is 13-7/8" × 9-3/4".

Table 4: MQTH-500 Single Duct Air Terminal Unit with Integral Attenuator—Unit Dimensions, in (mm) and Weights, lb (kg)

Model Number	Inlet Size	A	Width	Height	Unit Weight
MQTH504	3-7/8 (99)	5 (127)	12 (305)	8 (203)	24 (11)
MQTH505	4-7/8 (124)	5 (127)	12 (305)	8 (203)	24 (11)
MQTH506	5-7/8 (149)	5 (127)	12 (305)	8 (203)	24 (11)
MQTH508	7-7/8 (200)	5 (127)	12 (305)	10 (254)	28 (13)
MQTH510	9-7/8 (251)	5 (127)	14 (356)	12-1/2 (318)	34 (15)
MQTH512	11-7/8 (302)	5 (127)	16 (406)	15 (381)	41 (19)
MQTH514	13-7/8 (353)	5 (127)	20 (508)	17-1/2 (445)	47 (21)
MQTH516	15-7/8 (403)	5 (127)	24 (610)	18 (457)	54 (25)
MQTH520	19-7/8×15-7/8 (505×403)	6 (152)	30 (762)	20 (508)	77 (35)
MQTH524	23-7/8×15-7/8 (607×403)	6 (152)	38 (965)	20 (508)	93 (42)



Figure 6: MQTH-500 Single Duct Air Terminal Unit with Integral Attenuator and Hot Water Coil

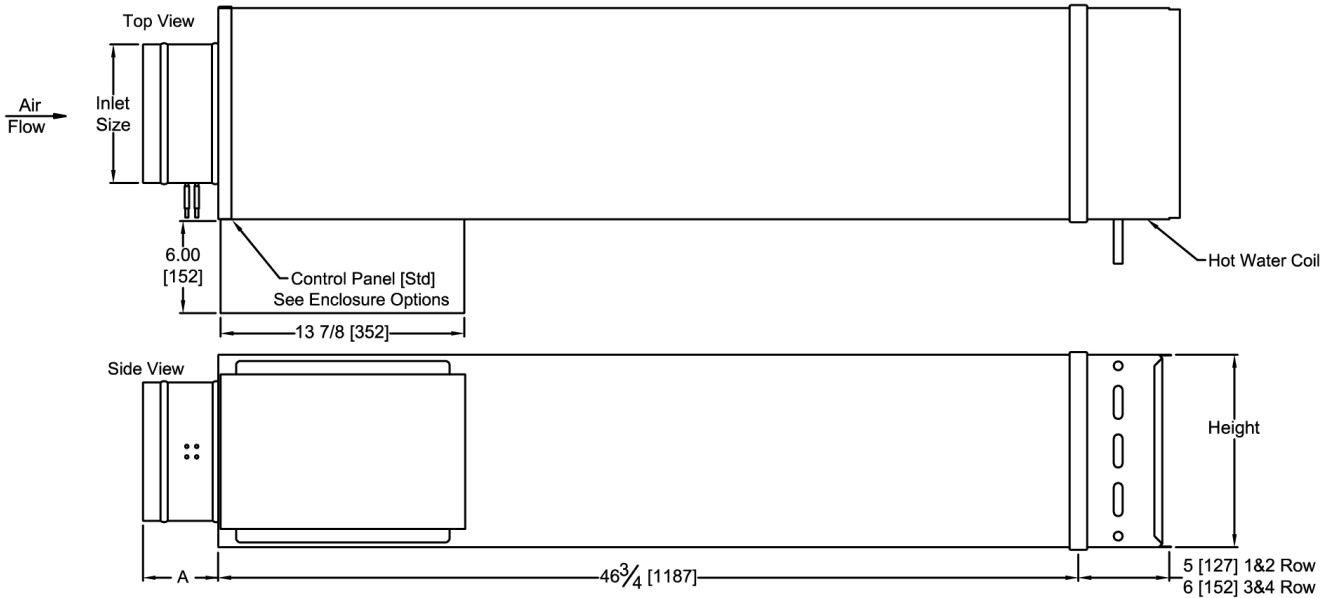

The standard location for control panel is Right Hand on Model MQTH.  
 Looking in the direction of airflow, the control panel is on the right.

The control panel will overhang the top and bottom of model MQTH506 1" (25.4 mm).  
 Control Panel Mounting Surface width by height is 13-7/8" × 9-3/4".

Table 5: MQTH-500 Single Duct Air Terminal Unit with Integral Attenuator and Hot Water Coil—Unit Dimensions, in (mm) and Weights, lb (kg)

Model Number	Inlet Size	A	Width	Height	Unit Weight			
					1 Row	2 Row	3 Row	4 Row
MQTH504	3-7/8 (99)	5 (127)	12 (305)	8 (203)	29 (13)	30 (14)	33 (15)	35 (16)
MQTH505	4-7/8 (124)	5 (127)	12 (305)	8 (203)	29 (13)	31 (14)	33 (15)	35 (16)
MQTH506	5-7/8 (149)	5 (127)	12 (305)	8 (203)	29 (13)	32 (14)	33 (15)	35 (16)
MQTH508	7-7/8 (200)	5 (127)	12 (305)	10 (254)	33 (15)	35 (16)	39 (18)	41 (19)
MQTH510	9-7/8 (251)	5 (127)	14 (356)	12-1/2 (318)	40 (18)	35 (16)	48 (22)	54 (25)
MQTH512	11-7/8 (302)	5 (127)	16 (406)	15 (381)	50 (23)	43 (20)	59 (27)	62 (28)
MQTH514	13-7/8 (353)	5 (127)	20 (508)	17-1/2 (445)	57 (26)	53 (24)	71 (32)	76 (35)
MQTH516	15-7/8 (403)	5 (127)	24 (610)	18 (457)	67 (30)	62 (28)	79 (36)	84 (38)
MQTH520	19-7/8×15-7/8 (505×403)	6 (152)	30 (762)	20 (508)	94 (43)	73 (33)	108 (49)	116 (53)
MQTH524	23-7/8×15-7/8 (607×403)	6 (152)	38 (965)	20 (508)	114 (52)	124 (56)	134 (61)	144 (65)

# Performance Data

## MQTH-500 AHRI Certified Rating Points

### Certifications and Standards

- Units tested per ANSI/ASHRAE Standard 130
- All model sizes certified in accordance with AHRI 880 certification program
- ETL listed to meet requirements of UL 1995 and CSA 236
- Dual-density fiberglass insulation meets UL 181 and NFPA 90A requirements
- Insulation meets ASHRAE 62.1 requirements for resistance to mold growth and erosion



**Table 6: MQTH-500 AHRI Certified Radiated Sound Power,  $\Delta P_s = 1.5$  in.w.g.**

Unit Size	Min Ps	CFM	Octave Band					
			2	3	4	5	6	7
504	0.04	200	52	44	38	32	26	22
505	0.04	200	52	44	38	32	26	22
506	0.08	400	58	53	49	44	41	36
508	0.01	700	62	56	49	44	36	32
510	0.02	1100	58	60	52	46	40	35
512	0.01	1600	61	56	54	45	41	40
514	0.01	2100	62	57	55	45	38	34
516	0.03	2800	64	62	56	50	47	44
520	0.06	3000	69	67	65	61	55	48
524	0.04	5300	73	71	66	63	60	52

**Table 7: MQTH-500 AHRI Certified Discharge Sound Power,  $\Delta P_s = 1.5$  in.w.g.**

Unit Size	Min Ps	Fan CFM	Octave Band					
			2	3	4	5	6	7
504	0.04	200	65	60	55	51	46	39
505	0.04	200	65	60	55	51	46	39
506	0.08	400	67	64	60	53	49	49
508	0.01	700	75	71	62	58	55	53
510	0.02	1100	73	70	65	60	56	53
512	0.01	1600	68	67	62	60	59	57
514	0.01	2100	66	62	61	63	63	60
516	0.03	2800	74	69	66	64	64	60
520	0.06	3000	74	71	71	71	67	63
524	0.04	5300	86	85	81	77	74	71

**Table 8: MQTH-500 Casing Leakage**

Casing Leakage, CFM						
Inlet Size	0.25" $\Delta P_s$	0.50" $\Delta P_s$	1.00" $\Delta P_s$	1.50" $\Delta P_s$	2.0" $\Delta P_s$	3.0" $\Delta P_s$
6	2	3	4	5	6	7
8	2	3	5	6	6	8
10	3	4	6	8	9	10
12	3	5	7	9	10	12
14	4	6	9	11	12	15
16	5	7	10	12	14	17
20×16	5	7	10	12	14	17
24×16	6	8	12	14	17	20

**Table 9: MQTH-500 Damper Leakage**

Damper Leakage, CFM			
Inlet Size	1.5" $\Delta P_s$	3.0" $\Delta P_s$	6.0" $\Delta P_s$
6	3	4	7
8	3	4	7
10	4	5	7
12	4	5	7
14	4	6	8
16	4	6	8
20×16	N/A	N/A	N/A
24×16	N/A	N/A	N/A

**Table 10: MQTH-500 Radiated Sound Power at ΔPS = 0.50, 0.75, and 1.0 in.w.g.**

Unit Size	CFM (L/s)	Min Ps in.w.g. (Pa)	ΔPs = 0.50 in.w.g. (125 Pa)							ΔPs = 0.75 in.w.g. (187 Pa)							ΔPs = 1.0 in.w.g. (500 Pa)						
			Octave Band Sound Power, Lw, dB							Octave Band Sound Power, Lw, dB							Octave Band Sound Power, Lw, dB						
			2	3	4	5	6	7	NC	2	3	4	5	6	7	NC	2	3	4	5	6	7	NC
504/505 4 & 5 inch	50 (24)	0.005 (1.2)	41	32	19	19	15	7	<15	42	33	20	20	16	8	<15	43	34	21	21	17	9	<15
	100 (47)	0.015 (3.8)	43	34	23	22	19	13	<15	44	35	24	23	20	14	<15	45	36	25	24	21	15	<15
	150 (71)	0.027 (6.7)	46	38	29	26	21	16	<15	47	39	30	27	22	17	<15	48	40	31	28	23	18	<15
	200 (94)	0.038 (9.5)	49	41	35	29	23	18	<15	50	42	36	30	24	19	<15	51	43	37	31	25	20	<15
	250 (118)	0.059 (14.8)	51	43	39	32	28	26	<15	52	44	40	33	29	27	<15	53	45	41	34	30	28	<15
300 (142)	0.071 (17.6)	53	46	43	35	32	30	17	54	47	44	36	33	31	18	55	48	45	37	34	32	19	
506 6 inch	100 (47)	0.005 (1.2)	43	34	23	22	19	13	<15	44	35	24	23	20	14	<15	45	36	25	24	21	15	<15
	200 (94)	0.020 (5.0)	49	41	35	29	23	18	<15	50	42	36	30	24	19	<15	51	43	37	31	25	20	<15
	300 (142)	0.045 (11.2)	53	46	43	35	32	30	17	54	47	44	36	33	31	18	55	48	45	37	34	32	19
	400 (189)	0.080 (19.9)	55	50	46	41	38	32	20	56	51	47	42	39	33	21	57	52	48	43	40	34	22
	500 (236)	0.136 (33.9)	57	53	48	44	40	34	22	58	54	49	45	41	35	23	59	55	50	46	42	36	24
600 (283)	0.180 (44.8)	58	55	50	46	42	36	24	59	56	51	47	43	37	25	60	57	52	48	44	38	26	
508 8 inch	200 (94)	0.000 (0.0)	48	36	25	20	17	16	<15	50	39	30	26	20	19	<15	51	41	35	30	23	20	<15
	300 (142)	0.001 (0.2)	51	40	33	25	20	19	<15	53	43	37	31	24	21	<15	55	46	42	36	28	24	16
	600 (283)	0.003 (0.7)	54	44	37	33	25	20	<15	57	48	40	35	28	23	18	59	52	43	38	31	27	21
	700 (330)	0.005 (1.2)	56	46	40	35	27	21	17	58	50	42	37	30	25	20	61	53	45	40	33	28	23
	1000 (472)	0.008 (2.0)	60	52	46	42	34	27	22	62	54	48	44	36	30	25	65	57	50	45	39	33	29
1100 (519)	0.009 (2.2)	61	53	48	44	37	30	23	63	55	50	45	38	32	26	66	58	51	47	40	35	30	
510 10 inch	300 (142)	0.002 (0.5)	43	38	29	20	18	18	<15	45	40	32	23	19	19	<15	47	42	36	26	21	20	<15
	600 (283)	0.009 (2.2)	47	46	37	30	26	22	<15	50	48	42	33	28	24	15	52	51	46	36	31	25	20
	800 (378)	0.013 (3.2)	48	48	40	34	28	22	15	50	50	43	36	31	24	18	53	53	47	39	33	26	21
	1000 (472)	0.018 (4.5)	49	49	42	36	29	24	16	51	52	45	38	32	26	20	54	54	48	40	34	28	22
	1100 (519)	0.021 (5.2)	51	50	44	38	30	24	18	53	53	46	40	33	27	21	55	55	49	41	35	29	24
1400 (661)	0.028 (7.0)	55	55	48	42	34	28	24	58	57	49	43	36	30	26	60	58	50	43	37	31	27	
1700 (802)	0.036 (9.0)	57	57	53	44	38	32	27	60	58	54	45	39	34	29	63	61	55	48	42	36	31	
512 12 inch	430 (203)	0.000 (0.1)	46	37	29	22	19	20	<15	49	39	32	25	21	21	<15	51	41	36	28	23	23	<15
	800 (378)	0.001 (0.2)	50	42	35	28	26	29	<15	52	45	40	32	29	31	<15	54	48	45	36	32	32	19
	1450 (684)	0.008 (2.0)	52	47	43	36	31	31	17	55	49	47	39	34	33	21	57	52	50	41	37	36	24
	1600 (755)	0.010 (2.5)	54	48	46	39	33	32	20	56	50	48	40	35	35	22	58	53	51	42	38	37	25
	1950 (920)	0.015 (3.7)	55	51	50	42	37	36	24	57	53	51	43	39	37	25	59	54	52	44	41	39	26
2200 (1038)	0.022 (5.5)	56	52	51	43	39	37	25	58	53	52	44	40	39	26	61	55	53	45	42	40	27	
2500 (1180)	0.025 (6.2)	57	53	52	44	40	38	26	59	55	53	46	41	41	27	62	58	56	48	44	43	31	
514 14 inch	550 (260)	0.000 (0.0)	52	38	36	28	25	20	<15	53	39	37	29	26	21	<15	54	40	38	30	27	22	<15
	925 (437)	0.001 (0.2)	53	41	39	31	27	22	<15	54	42	40	32	28	23	<15	55	43	41	33	29	24	16
	1600 (755)	0.003 (0.7)	56	46	44	35	31	26	18	57	47	45	36	32	27	19	58	48	46	37	33	28	20
	1900 (897)	0.004 (1.0)	57	50	49	39	33	28	23	58	51	50	40	34	29	24	59	52	51	41	35	30	25
	2100 (991)	0.005 (1.2)	59	54	51	42	36	31	25	60	55	52	43	37	32	26	61	56	53	44	38	33	27
2600 (1227)	0.006 (1.5)	62	56	54	43	40	36	29	63	57	55	44	41	37	30	64	58	56	45	42	38	31	
3250 (1534)	0.007 (1.7)	64	60	57	46	44	40	32	65	61	58	47	45	41	33	66	62	59	48	46	42	34	
516 16 inch	750 (354)	0.001 (0.4)	54	39	30	24	19	17	<15	54	41	33	28	21	19	<15	55	43	35	30	24	20	16
	1100 (519)	0.006 (1.5)	56	45	36	29	24	20	17	56	47	39	32	26	22	17	57	49	41	34	29	24	18
	1500 (708)	0.010 (2.6)	58	51	41	35	31	26	20	58	53	44	38	33	28	21	59	55	46	40	36	30	24
	2400 (1133)	0.023 (5.7)	60	53	44	40	37	33	22	60	55	47	42	38	34	24	60	57	49	43	40	35	26
	2800 (1321)	0.030 (7.5)	61	54	47	42	39	35	23	61	56	49	44	40	36	25	62	58	51	45	42	37	27
3600 (1699)	0.045 (11.1)	62	57	52	46	42	39	26	63	59	53	48	43	40	28	64	60	55	49	44	41	30	
4400 (2076)	0.060 (15.0)	65	61	57	50	46	43	32	66	62	58	51	47	44	33	67	63	58	52	48	45	33	
520 20x16 inches	1100 (519)	0.008 (2.0)	51	45	33	29	27	23	<15	53	47	35	31	29	25	<15	55	49	37	33	31	27	16
	1600 (755)	0.024 (6.0)	53	51	43	39	32	29	19	55	53	45	41	34	31	21	57	55	47	43	36	33	24
	2500 (1180)	0.055 (13.7)	59	58	56	52	44	39	31	61	60	58	54	46	41	33	63	62	60	56	48	43	35
	3000 (1416)	0.060 (14.9)	64	62	60	56	50	43	35	66	64	62	58	52	45	37	68	66	64	60	54	47	39
	4600 (2171)	0.140 (34.8)	70	67	65	62	52	47	41	72	69	67	64	54	49	43	74	71	69	66	56	51	45
5300 (2501)	0.167 (41.6)	71	69	67	64	54	48	43	73	71	69	66	56	50	45	75	73	71	68	58	52	47	
6200 (2926)	0.202 (50.3)	74	71	69	66	56	49	45	76	73	71	68	58	51	47	78	75	73	70	60	53	49	
524 24x16 inches	1250 (590)	0.010 (2.5)	54	45	35	32	30	23	<15	55	46	37	34	31	25	16	55	47	39	35	32	26	16
	2000 (944)	0.015 (3.7)	58	51	44	41	36	31	20	59	52	45	42	37	32	21	59	52	46	42	38	32	21
	3000 (1416)	0.020 (5.0)	63	56	50	47	42	37	26	64	57	51	48	43	38	27	64	57	52	48	44	38	27
	4000 (1888)	0.025 (6.2)	66	61	58	53	49	42	33	67	62	59	54	50	43	34	68	62	59	55	50	44	34
	5300 (2501)	0.040 (10.0)	70	66	63	59	55	49	38	72	67	64	61	56	50	39	73	68	64	62	57	51	39
6000 (2831)	0.050 (12.4)	73	68	66	61	57	51	42	75	69	67	63	58	52	43	76	70	68	64	59	53	44	
7200 (3398)	0.070 (17.4)	76	72	68	66	60	54	44	77	73	70	68	61	55	46	78	74	71	69	62	56	47	

**NOTE 1:** Performance data contained within a bold border outline are AHRI certified data.

**NOTE 2:** Performance data not contained within a bold border outline are application ratings. Application ratings are outside the scope of the Certification Program.

**NOTE 3:** Performance data is obtained from laboratory testing in accordance with AHRI 880-2011 and ANSI/ASHRAE 130-2008.

**NOTE 4:** NC values are calculated using attenuation credits outlined in Appendix E of AHRI 885-2008.

**NOTE 5:** Discharge Sound power levels shown with End Reflection Corrections Included in dB (ref: 10<sup>-12</sup> watts).

**NOTE 6:** Minimum Ps is the static pressure drop across the air terminal unit while the inlet damper is in the wide-open position at a given airflow rate.

**Table 11: MQTH-500 Radiated Sound Power at ΔPS = 1.50, 2.0, and 3.0 in.w.g.**

Unit Size	CFM (L/s)	Min Ps in.w.g. (Pa)	ΔPs = 1.5 in.w.g. (375 Pa)							ΔPs = 2.0 in.w.g. (500 Pa)							ΔPs = 3.0 in.w.g. (750 Pa)						
			Octave Band Sound Power, Lw, dB							Octave Band Sound Power, Lw, dB							Octave Band Sound Power, Lw, dB						
			2	3	4	5	6	7	NC	2	3	4	5	6	7	NC	2	3	4	5	6	7	NC
504/505 4 & 5 inch	50 (24)	0.005 (1.2)	44	35	22	22	18	11	<15	44	36	23	22	19	13	<15	45	38	25	24	23	18	<15
	100 (47)	0.015 (3.8)	46	37	26	25	22	17	<15	46	38	27	25	23	19	<15	47	40	29	27	27	24	<15
	150 (71)	0.027 (6.7)	49	41	32	29	24	20	<15	49	42	33	29	25	22	<15	50	44	35	31	29	27	<15
	200 (94)	0.038 (9.5)	52	44	38	32	26	22	<15	52	45	39	32	27	24	<15	53	47	41	34	31	29	<15
	250 (118)	0.059 (14.8)	54	46	42	35	31	30	15	54	47	43	35	32	32	17	55	49	45	37	36	37	19
	300 (142)	0.071 (17.6)	56	49	46	38	35	34	20	56	50	47	38	36	36	21	57	52	49	40	40	41	23
506 6 inch	100 (47)	0.005 (1.2)	46	37	26	25	22	17	<15	46	38	27	25	23	19	<15	47	40	29	27	27	24	<15
	200 (94)	0.020 (5.0)	52	44	38	32	26	22	<15	52	45	39	32	27	24	<15	53	47	41	34	31	29	<15
	300 (142)	0.045 (11.2)	56	49	46	38	35	34	20	56	50	47	38	36	36	21	57	52	49	40	40	41	23
	400 (189)	0.080 (19.9)	58	53	49	44	41	36	23	58	54	50	44	42	38	24	59	56	52	46	46	43	26
	500 (236)	0.136 (33.9)	60	56	51	47	43	38	25	61	57	52	47	44	40	26	61	59	54	49	48	45	29
	600 (283)	0.180 (44.8)	61	58	53	49	45	40	27	62	59	54	49	46	42	29	62	61	56	51	50	47	31
508 8 inch	200 (94)	0.000 (0.0)	52	42	37	33	26	22	<15	52	43	38	35	29	23	<15	53	45	39	36	32	27	<15
	300 (142)	0.001 (0.2)	55	46	43	38	32	29	17	55	46	43	40	35	33	17	56	47	45	42	40	38	19
	600 (283)	0.003 (0.7)	60	55	47	42	36	32	24	61	57	51	45	39	36	26	61	59	54	49	43	41	29
	700 (330)	0.005 (1.2)	62	57	52	44	39	34	26	63	60	53	47	40	37	29	64	61	56	51	44	41	31
	1000 (472)	0.008 (2.0)	67	60	53	48	42	36	31	68	63	56	50	44	39	33	70	66	60	54	47	42	37
	1100 (519)	0.009 (2.2)	68	61	54	50	43	38	32	69	64	57	52	45	40	34	71	67	61	56	49	44	38
510 10 inch	300 (142)	0.002 (0.5)	50	46	40	30	25	24	<15	54	47	40	32	26	25	<15	56	47	42	35	29	26	17
	600 (283)	0.009 (2.2)	55	55	50	40	35	29	24	59	55	51	43	39	35	25	60	56	51	45	42	40	25
	800 (378)	0.013 (3.2)	56	57	51	43	37	30	26	61	60	53	46	42	38	29	63	62	56	49	45	42	32
	1000 (472)	0.018 (4.5)	57	58	52	44	38	32	27	62	63	56	49	44	40	33	64	67	60	52	47	45	38
	1100 (519)	0.021 (5.2)	58	58	52	44	38	32	27	63	64	57	50	45	41	34	65	68	61	53	48	47	39
	1400 (661)	0.028 (7.0)	63	62	54	47	41	35	32	70	66	58	52	47	44	37	71	70	63	56	50	49	41
512 12 inch	1700 (802)	0.036 (9.0)	66	65	59	54	46	40	35	72	67	60	55	50	48	38	73	72	64	58	53	51	44
	430 (203)	0.000 (0.1)	54	45	40	31	26	26	<15	55	47	41	34	29	28	16	56	47	44	38	34	33	18
	800 (378)	0.001 (0.2)	57	51	49	40	35	35	23	58	54	53	45	40	41	27	58	56	56	50	44	42	31
	1450 (684)	0.008 (2.0)	60	55	53	44	40	39	27	62	60	58	49	44	43	33	63	64	63	55	48	45	38
	1600 (755)	0.010 (2.5)	61	56	54	45	41	40	29	63	60	58	49	44	44	33	65	65	63	55	48	46	38
	1950 (920)	0.015 (3.7)	62	58	56	47	44	42	31	64	62	60	51	47	47	35	66	66	65	56	50	49	41
514 14 inch	2200 (1038)	0.022 (5.5)	64	59	57	49	45	44	32	66	62	60	52	48	47	35	68	67	65	56	51	50	41
	2500 (1180)	0.025 (6.2)	65	61	59	51	48	46	34	67	65	63	55	51	49	38	69	68	67	60	52	51	43
	550 (260)	0.000 (0.0)	55	41	39	31	28	23	16	55	41	39	31	28	23	16	56	42	40	32	29	24	17
	925 (437)	0.001 (0.2)	56	43	41	33	30	24	17	56	44	42	34	30	25	17	57	45	43	35	31	26	18
	1600 (755)	0.003 (0.7)	58	49	46	38	33	28	20	59	49	47	38	34	29	21	60	50	48	39	35	30	22
	1900 (897)	0.004 (1.0)	60	53	52	41	36	31	26	60	53	52	42	36	31	26	61	54	53	43	37	32	27
516 16 inch	2100 (991)	0.005 (1.2)	62	57	55	45	40	34	30	62	57	54	45	40	34	29	63	58	55	46	40	35	30
	2600 (1227)	0.006 (1.5)	65	59	57	46	43	39	32	65	59	57	46	43	39	32	66	60	58	47	44	40	33
	3250 (1534)	0.007 (1.7)	67	63	60	49	47	43	35	67	63	60	49	47	43	35	68	64	61	50	48	44	36
	750 (354)	0.001 (0.4)	56	45	39	33	28	23	17	57	47	42	36	31	26	18	59	51	47	40	36	30	21
	1100 (519)	0.006 (1.5)	58	51	45	39	34	28	20	59	53	49	44	38	32	23	61	56	51	49	40	35	25
	1500 (708)	0.010 (2.6)	60	57	51	45	41	36	26	61	59	55	50	45	42	30	63	61	57	53	49	47	32
520 20x16 inches	2400 (1133)	0.023 (5.7)	63	61	55	49	46	42	31	65	65	60	54	51	48	35	68	67	64	60	58	56	39
	2800 (1321)	0.030 (7.5)	64	62	56	50	47	44	32	67	66	61	56	53	50	37	69	69	65	62	61	59	41
	3600 (1699)	0.045 (11.1)	67	64	59	54	50	47	34	69	67	63	58	56	53	38	71	70	67	64	63	62	43
	4400 (2076)	0.060 (15.0)	69	66	62	56	54	51	37	71	69	65	60	59	56	41	73	72	69	66	65	64	45
	1100 (519)	0.008 (2.0)	56	50	38	34	32	28	18	57	51	39	35	33	29	19	59	53	41	37	35	31	21
	1600 (755)	0.024 (6.0)	58	56	48	44	37	34	25	59	57	49	45	38	35	26	61	59	51	47	40	37	28
524 24x16 inches	2500 (1180)	0.055 (13.7)	64	63	61	57	49	44	36	65	64	62	58	50	45	37	67	67	66	64	60	52	47
	3000 (1416)	0.060 (14.9)	69	67	65	61	55	48	41	70	68	66	62	56	49	42	72	70	68	64	58	51	44
	4600 (2171)	0.140 (34.8)	75	72	70	67	57	52	46	76	73	71	68	58	53	47	78	75	73	70	60	55	49
	5300 (2501)	0.167 (41.6)	76	74	72	69	59	53	48	77	75	73	70	60	54	49	79	77	75	72	62	56	51
	6200 (2926)	0.202 (50.3)	79	76	74	71	61	54	50	80	77	75	72	62	55	51	82	79	77	74	64	57	54
	1250 (590)	0.010 (2.5)	58	50	42	38	35	29	20	58	52	44	39	37	32	20	59	55	49	42	39	35	24
524 24x16 inches	2000 (944)	0.015 (3.7)	62	55	49	45	41	35	25	62	59	53	49	45	39	28	63	63	57	53	49	43	33
	3000 (1416)	0.020 (5.0)	67	60	55	51	47	41	31	67	64	59	55	51	45	34	69	69	64	58	55	48	40
	4000 (1888)	0.025 (6.2)	71	65	62	58	53	47	37	72	70	68	63	57	52	44	74	72	70	66	60	55	46
	5300 (2501)	0.040 (10.0)	76	71	71	65	60	54	47	78	73	71	68	62	55	47	80	76	75	70	64	58	51
	6000 (2831)	0.050 (12.4)	77	72	70	66	61	55	46	81	75	73	69	63	57	49	83	77	76	72	65	59	53
	7200 (3398)	0.070 (17.4)	81	76	74	72	65	59	50	83	79	76	74	67	60	53	85	81	79	76	69	62	56

**NOTE 1:** Performance data contained within a bold border outline are AHRI certified data.

**NOTE 2:** Performance data not contained within a bold border outline are application ratings. Application ratings are outside the scope of the Certification Program.

**NOTE 3:** Performance data is obtained from laboratory testing in accordance with AHRI 880-2011 and ANSI/ASHRAE 130-2008.

**NOTE 4:** NC values are calculated using attenuation credits outlined in Appendix E of AHRI 885-2008.

**NOTE 5:** Discharge Sound power levels shown with End Reflection Corrections Included in dB (ref: 10<sup>-12</sup> watts).

**NOTE 6:** Minimum Ps is the static pressure drop across the air terminal unit while the inlet damper is in the wide-open position at a given airflow rate.

**Table 12: MQTH-500 Discharge Sound Power at ΔPS = 0.50, 0.75, and 1.0 in.w.g.**

Unit Size	CFM (L/s)	Min Ps in.w.g. (Pa)	ΔPs = 0.50 in.w.g. (125 Pa)								ΔPs = 0.75 in.w.g. (187 Pa)								ΔPs = 1.0 in.w.g. (250 Pa)							
			Octave Band Sound Power, Lw, dB								Octave Band Sound Power, Lw, dB								Octave Band Sound Power, Lw, dB							
			2	3	4	5	6	7	NC	NC w/ SA	2	3	4	5	6	7	NC	NC w/ SA	2	3	4	5	6	7	NC	NC w/ SA
504/505 4 & 5 inch	50 (24)	0.005 (1)	59	47	39	35	29	22	<15	<15	60	51	45	41	34	27	<15	<15	60	55	50	47	39	31	<15	<15
	100 (47)	0.015 (4)	60	49	39	34	30	26	<15	<15	61	53	46	41	35	30	16	<15	61	56	52	47	40	34	16	<15
	150 (71)	0.027 (7)	61	51	42	37	32	27	16	<15	62	54	48	43	37	32	17	<15	62	57	53	48	42	36	17	<15
	200 (94)	0.038 (9)	62	52	45	40	34	28	17	<15	63	55	49	45	39	33	18	16	63	58	53	49	44	37	18	16
	250 (118)	0.059 (15)	63	54	47	42	36	32	18	16	64	57	51	46	41	36	20	17	64	59	55	49	45	40	20	17
506 6 inch	300 (142)	0.071 (18)	64	56	51	45	38	34	16	<15	64	59	54	48	42	39	16	<15	64	61	57	50	46	43	19	<15
	100 (47)	0.005 (1.2)	60	49	39	34	30	26	<15	<15	61	53	46	41	35	30	16	<15	61	56	52	47	40	34	16	<15
	200 (94)	0.020 (5.0)	62	52	45	40	34	28	17	<15	63	55	49	45	39	33	18	16	63	58	53	49	44	37	18	16
	300 (142)	0.045 (11.2)	64	56	51	45	38	34	16	<15	64	59	54	48	42	39	16	<15	64	61	57	50	46	43	19	<15
	400 (189)	0.080 (19.9)	65	60	55	49	42	40	18	<15	65	61	57	50	45	44	19	<15	65	62	58	51	47	47	20	15
508 8 inch	500 (236)	0.136 (33.9)	68	64	59	54	48	45	22	18	68	65	61	55	50	48	24	19	68	66	62	56	52	50	25	20
	600 (283)	0.180 (44.8)	69	67	62	59	52	49	26	21	69	68	63	60	54	50	27	22	69	68	64	60	55	51	27	22
	200 (94)	0.000 (0.0)	62	53	46	40	34	30	17	<15	63	56	50	43	37	34	18	16	66	60	55	49	44	42	22	20
	300 (142)	0.001 (0.2)	64	57	48	43	38	33	16	<15	65	60	52	46	41	37	18	<15	68	64	58	53	49	45	22	19
	600 (283)	0.003 (0.7)	69	63	54	51	43	39	22	20	71	65	56	53	46	42	25	22	73	69	61	58	53	48	28	25
510 10 inch	700 (330)	0.005 (1.2)	71	65	56	54	45	40	25	22	72	67	58	55	48	43	26	23	74	70	63	60	54	50	29	26
	1000 (472)	0.008 (2.0)	75	70	62	60	52	47	28	25	77	71	64	63	54	49	30	27	79	74	67	65	58	53	33	30
	1100 (519)	0.009 (2.2)	76	71	64	62	56	50	29	26	78	72	66	64	56	51	31	29	80	75	69	67	60	54	34	31
	300 (142)	0.002 (0.5)	58	55	46	43	36	31	<15	<15	59	58	50	46	39	35	15	<15	62	62	55	52	46	43	20	16
	600 (283)	0.009 (2.2)	62	59	50	46	38	36	16	<15	64	62	52	49	42	39	20	16	67	65	58	54	49	46	24	20
512 12 inch	800 (378)	0.013 (3.2)	65	62	53	49	41	39	19	15	67	64	55	51	44	42	21	18	69	68	60	56	51	48	26	22
	1000 (472)	0.018 (4.5)	68	63	55	52	41	40	20	17	69	65	57	53	44	43	22	19	71	68	62	58	55	52	26	22
	1100 (519)	0.021 (5.2)	68	64	57	53	45	43	21	18	70	66	59	55	48	45	24	20	72	69	63	58	55	52	27	24
	1400 (661)	0.028 (7.0)	72	70	62	59	52	50	28	25	74	71	64	62	54	52	29	26	76	74	67	64	58	56	33	29
	1700 (802)	0.036 (9.0)	76	74	65	64	59	55	33	29	78	75	67	66	59	56	34	31	80	78	70	69	63	59	38	34
514 14 inch	430 (203)	0.000 (0.1)	55	47	46	45	39	35	<15	<15	58	51	48	48	44	41	<15	<15	60	53	49	49	46	44	<15	<15
	800 (378)	0.001 (0.2)	57	55	52	50	46	40	<15	<15	60	59	54	53	51	46	15	<15	62	59	54	53	51	48	15	<15
	1450 (684)	0.008 (2.0)	61	59	58	54	50	45	15	<15	64	63	60	57	55	51	20	16	65	64	60	58	56	53	21	18
	1600 (755)	0.010 (2.5)	62	60	59	55	51	46	16	<15	65	64	61	58	56	52	21	18	67	66	62	59	58	55	24	20
	1950 (920)	0.015 (3.7)	64	61	59	56	52	48	18	<15	67	65	61	59	57	54	22	19	70	68	64	62	61	59	26	22
516 16 inch	2200 (1038)	0.022 (5.5)	64	61	60	57	53	48	18	<15	68	65	62	60	58	55	22	19	71	69	65	63	62	60	27	24
	2500 (1180)	0.025 (6.2)	66	62	61	57	53	50	19	15	70	66	64	61	59	57	24	20	73	70	67	64	63	62	28	25
	550 (260)	0.000 (0.0)	46	38	36	34	27	22	<15	<15	51	45	43	41	36	31	<15	<15	57	51	49	49	44	39	<15	<15
	925 (437)	0.001 (0.2)	46	38	38	36	30	23	<15	<15	52	45	45	44	39	32	<15	<15	57	52	51	51	47	42	<15	<15
	1600 (755)	0.003 (0.7)	49	43	43	42	37	32	<15	<15	55	49	49	48	44	40	<15	<15	60	55	54	55	52	48	<15	<15
520 20x16 inches	1900 (897)	0.004 (1.0)	51	45	45	44	40	36	<15	<15	56	51	50	50	47	44	<15	<15	60	56	55	56	54	51	15	<15
	2100 (991)	0.005 (1.2)	53	48	49	48	44	41	<15	<15	57	53	53	53	50	47	<15	<15	62	57	57	58	57	54	18	<15
	2600 (1227)	0.006 (1.5)	58	52	52	51	48	47	<15	<15	61	56	55	56	54	52	16	<15	65	59	59	60	59	57	21	<15
	3250 (1534)	0.007 (1.7)	64	57	54	54	52	55	19	<15	66	60	57	58	56	58	22	<15	67	62	60	61	61	60	24	16
	750 (354)	0.001 (0.4)	48	43	41	33	29	25	<15	<15	54	49	45	40	37	34	<15	<15	60	55	53	48	46	43	<15	<15
524 24x16 inches	1100 (519)	0.006 (1.5)	50	45	43	36	32	26	<15	<15	56	51	47	43	40	35	<15	<15	62	57	53	50	48	44	<15	<15
	1500 (708)	0.010 (2.6)	53	48	45	41	36	31	<15	<15	58	53	50	47	43	39	<15	<15	64	59	56	53	51	47	15	<15
	2400 (1133)	0.023 (5.7)	60	55	53	50	44	40	<15	<15	64	59	57	54	50	46	15	<15	68	63	61	58	56	52	20	18
	2800 (1321)	0.030 (7.5)	64	58	58	55	49	44	<15	<15	67	62	61	58	54	49	19	16	71	66	64	61	59	55	24	21
	3600 (1699)	0.045 (11.1)	69	63	64	60	55	50	20	18	71	66	65	62	59	54	24	21	74	69	67	64	63	58	27	25
520 20x16 inches	4400 (2076)	0.060 (15.0)	74	67	68	65	57	53	26	25	75	69	68	66	60	57	27	26	77	71	69	67	64	61	30	29
	1100 (519)	0.008 (2.0)	49	43	42	36	34	34	<15	<15	54	50	49	43	42	42	<15	<15	59	56	55	50	49	49	<15	<15
	1600 (755)	0.024 (6.0)	54	50	48	42	39	36	<15	<15	58	55	53	48	46	43	<15	<15	62	59	58	54	52	50	15	<15
	2500 (1180)	0.055 (13.7)	64	62	59	54	51	44	19	16	66	64	61	58	55	50	21	19	68	66	63	61	58	55	24	21
	3000 (1416)	0.060 (14.9)	69	67	64	60	57	52	25	22	71	68	65	62	60	55	26	24	72	69	66	64	62	58	27	25
524 24x16 inches	4600 (2171)	0.140 (34.8)	76	73	72	70	63	55	32	29	78	75	74	73	66	59	34	32	79	76	75	75	68	62	35	33
	5300 (2501)	0.167 (41.6)	80	76	75	74	66	57	35	33	82	78	77	76	69	60	38	35	83	79	78	78	71	63	39	37
	6200 (2926)	0.202 (50.3)	83	79	78	79	69	58	39	37	85	80	79	81	72	62	40	39	86	81	81	83	74	65	41	40
	1250 (590)	0.010 (2.5)	47	52	45	44	38	35	<15	<15	60	58	53	51	48	45	<15	<15	65	63	61	58	58	54	20	18
	2000 (944)	0.015 (3.7)	60	61	55	52	48	46	18	15	65	64	60	58	54	51	21	19	68	67	64	63	59	57	25	22
524 24x16 inches	3000 (1416)	0.020 (5.0)	71																							

**Table 13: MQTH-500 Discharge Sound Power at ΔPS = 1.50, 2.0, and 3.0 in.w.g.**

Unit Size	CFM (L/s)	Min Ps in.w.g. (Pa)	ΔPs = 1.5 in.w.g. (375 Pa)								ΔPs = 2.0 in.w.g. (500 Pa)								ΔPs = 3.0 in.w.g. (750 Pa)							
			Octave Band Sound Power, Lw, dB								Octave Band Sound Power, Lw, dB								Octave Band Sound Power, Lw, dB							
			2	3	4	5	6	7	NC	NC w/ SA	2	3	4	5	6	7	NC	NC w/ SA	2	3	4	5	6	7	NC	NC w/ SA
504/505 4 & 5 inch	50 (24)	0.005 (1)	62	57	52	49	41	33	<b>17</b>	<b>&lt;15</b>	62	57	52	49	41	33	<b>17</b>	<b>&lt;15</b>	64	59	52	51	43	35	<b>20</b>	<b>17</b>
	100 (47)	0.015 (4)	63	58	54	49	42	36	<b>18</b>	<b>16</b>	63	58	54	49	42	36	<b>18</b>	<b>16</b>	65	60	54	51	44	38	<b>21</b>	<b>18</b>
	150 (71)	0.027 (7)	64	59	55	50	44	38	<b>20</b>	<b>17</b>	64	59	55	50	44	38	<b>20</b>	<b>17</b>	66	61	55	52	46	40	<b>22</b>	<b>20</b>
	200 (94)	0.038 (9)	65	60	55	51	46	39	<b>21</b>	<b>18</b>	65	60	55	51	46	39	<b>21</b>	<b>18</b>	67	62	55	53	48	41	<b>23</b>	<b>21</b>
	250 (118)	0.059 (15)	66	61	57	51	47	42	<b>22</b>	<b>20</b>	66	61	57	51	47	42	<b>22</b>	<b>20</b>	68	63	59	53	49	44	<b>25</b>	<b>22</b>
506 6 inch	300 (142)	0.071 (18)	66	63	59	52	48	45	<b>21</b>	<b>16</b>	66	63	59	52	48	45	<b>21</b>	<b>16</b>	68	65	61	54	50	47	<b>24</b>	<b>19</b>
	100 (47)	0.005 (1.2)	63	58	54	49	42	36	<b>18</b>	<b>16</b>	63	58	54	49	42	36	<b>18</b>	<b>16</b>	65	60	54	51	44	38	<b>21</b>	<b>18</b>
	200 (94)	0.020 (5.0)	65	60	55	51	46	39	<b>21</b>	<b>18</b>	65	60	55	51	46	39	<b>21</b>	<b>18</b>	67	62	55	53	48	41	<b>23</b>	<b>21</b>
	300 (142)	0.045 (11.2)	66	63	59	52	48	45	<b>21</b>	<b>16</b>	66	63	59	52	48	45	<b>21</b>	<b>16</b>	68	65	61	54	50	47	<b>24</b>	<b>19</b>
	400 (189)	0.080 (19.9)	67	64	60	53	49	49	<b>22</b>	<b>18</b>	67	64	60	53	49	49	<b>22</b>	<b>18</b>	69	67	62	55	51	51	<b>26</b>	<b>21</b>
508 8 inch	500 (236)	0.136 (33.9)	70	68	64	58	54	52	<b>27</b>	<b>22</b>	70	68	64	58	54	52	<b>27</b>	<b>22</b>	72	70	66	60	56	54	<b>29</b>	<b>25</b>
	600 (283)	0.180 (44.8)	71	70	66	62	57	53	<b>29</b>	<b>25</b>	71	70	66	62	57	53	<b>29</b>	<b>25</b>	73	72	68	64	59	55	<b>32</b>	<b>27</b>
	200 (94)	0.000 (0.0)	66	60	54	50	46	44	<b>22</b>	<b>0</b>	67	61	55	52	48	46	<b>23</b>	<b>21</b>	68	62	56	54	50	48	<b>25</b>	<b>22</b>
	300 (142)	0.001 (0.2)	68	64	56	53	49	48	<b>22</b>	<b>0</b>	69	65	57	55	51	50	<b>24</b>	<b>20</b>	70	66	58	57	53	52	<b>25</b>	<b>21</b>
	600 (283)	0.003 (0.7)	73	68	59	56	53	52	<b>27</b>	<b>22</b>	74	69	60	58	55	54	<b>29</b>	<b>26</b>	75	70	61	60	57	56	<b>30</b>	<b>27</b>
510 10 inch	700 (330)	0.005 (1.2)	75	71	62	58	55	53	<b>31</b>	<b>25</b>	76	72	63	60	57	55	<b>32</b>	<b>29</b>	77	73	64	62	59	57	<b>33</b>	<b>30</b>
	1000 (472)	0.008 (2.0)	80	75	67	66	61	58	<b>34</b>	<b>33</b>	81	76	68	68	63	60	<b>35</b>	<b>32</b>	82	77	69	70	65	62	<b>37</b>	<b>34</b>
	1100 (519)	0.009 (2.2)	81	76	69	68	62	60	<b>35</b>	<b>36</b>	82	77	70	70	64	62	<b>37</b>	<b>34</b>	83	78	71	72	66	64	<b>38</b>	<b>35</b>
	300 (142)	0.002 (0.5)	62	62	56	53	48	45	<b>20</b>	<b>15</b>	62	62	56	53	48	45	<b>20</b>	<b>16</b>	64	64	57	55	50	48	<b>22</b>	<b>19</b>
	600 (283)	0.009 (2.2)	68	66	61	57	52	49	<b>25</b>	<b>20</b>	68	66	61	57	52	49	<b>25</b>	<b>21</b>	70	68	63	59	55	53	<b>27</b>	<b>24</b>
512 12 inch	800 (378)	0.013 (3.2)	70	68	63	58	54	51	<b>26</b>	<b>21</b>	70	68	63	58	54	51	<b>26</b>	<b>22</b>	72	70	65	61	57	53	<b>28</b>	<b>25</b>
	1000 (472)	0.018 (4.5)	72	69	64	59	55	52	<b>27</b>	<b>22</b>	72	69	64	59	55	52	<b>27</b>	<b>24</b>	74	71	66	61	57	54	<b>29</b>	<b>26</b>
	1100 (519)	0.021 (5.2)	73	70	65	60	56	53	<b>28</b>	<b>24</b>	73	70	65	60	56	53	<b>28</b>	<b>25</b>	74	72	68	62	59	55	<b>31</b>	<b>27</b>
	1400 (661)	0.028 (7.0)	77	75	69	65	60	57	<b>34</b>	<b>29</b>	77	75	69	65	60	57	<b>34</b>	<b>31</b>	79	76	71	66	63	60	<b>35</b>	<b>32</b>
	1700 (802)	0.036 (9.0)	81	79	72	70	64	60	<b>39</b>	<b>34</b>	81	79	72	70	64	60	<b>39</b>	<b>35</b>	83	81	74	71	66	64	<b>41</b>	<b>38</b>
514 14 inch	430 (203)	0.000 (0.1)	61	55	49	50	47	46	<b>&lt;15</b>	<b>&lt;15</b>	62	56	50	51	48	47	<b>&lt;15</b>	<b>&lt;15</b>	64	58	52	53	50	49	<b>16</b>	<b>&lt;15</b>
	800 (378)	0.001 (0.2)	63	58	52	53	50	49	<b>&lt;15</b>	<b>&lt;15</b>	64	59	53	54	51	50	<b>15</b>	<b>&lt;15</b>	66	61	55	56	53	52	<b>18</b>	<b>&lt;15</b>
	1450 (684)	0.008 (2.0)	66	64	59	58	56	54	<b>21</b>	<b>16</b>	67	65	60	59	57	55	<b>22</b>	<b>19</b>	69	67	62	61	59	57	<b>25</b>	<b>21</b>
	1600 (755)	0.010 (2.5)	68	67	62	60	59	57	<b>25</b>	<b>20</b>	69	68	63	61	60	58	<b>26</b>	<b>22</b>	71	70	65	63	62	60	<b>28</b>	<b>25</b>
	1950 (920)	0.015 (3.7)	73	71	66	65	64	63	<b>29</b>	<b>25</b>	74	72	67	66	65	64	<b>31</b>	<b>27</b>	76	74	69	68	67	66	<b>33</b>	<b>29</b>
516 16 inch	2200 (1038)	0.022 (5.5)	74	72	67	66	66	64	<b>31</b>	<b>26</b>	75	73	68	67	67	65	<b>32</b>	<b>28</b>	77	75	70	69	69	67	<b>34</b>	<b>31</b>
	2500 (1180)	0.025 (6.2)	76	73	69	67	67	66	<b>32</b>	<b>27</b>	77	74	70	68	68	67	<b>33</b>	<b>29</b>	79	76	72	70	70	69	<b>35</b>	<b>32</b>
	550 (260)	0.000 (0.0)	62	58	56	56	53	48	<b>15</b>	<b>&lt;15</b>	64	60	58	58	55	50	<b>18</b>	<b>15</b>	67	63	61	61	58	53	<b>21</b>	<b>19</b>
	925 (437)	0.001 (0.2)	63	59	57	58	55	51	<b>15</b>	<b>&lt;15</b>	65	61	59	60	57	53	<b>18</b>	<b>15</b>	68	64	62	63	60	56	<b>21</b>	<b>19</b>
	1600 (755)	0.003 (0.7)	65	61	60	61	59	56	<b>20</b>	<b>&lt;15</b>	67	63	62	63	61	58	<b>22</b>	<b>18</b>	70	66	65	66	64	61	<b>25</b>	<b>21</b>
520 20x16 inches	1900 (897)	0.004 (1.0)	65	61	60	62	61	58	<b>22</b>	<b>&lt;15</b>	67	63	62	64	63	60	<b>24</b>	<b>18</b>	70	66	65	67	66	63	<b>27</b>	<b>21</b>
	2100 (991)	0.005 (1.2)	66	62	61	63	63	60	<b>24</b>	<b>&lt;15</b>	68	64	63	65	65	62	<b>26</b>	<b>19</b>	71	67	66	68	68	65	<b>29</b>	<b>22</b>
	2600 (1227)	0.006 (1.5)	68	63	62	64	64	62	<b>26</b>	<b>16</b>	70	65	64	66	66	64	<b>28</b>	<b>20</b>	73	68	67	69	69	67	<b>31</b>	<b>24</b>
	3250 (1534)	0.007 (1.7)	69	64	63	65	65	63	<b>27</b>	<b>17</b>	71	66	65	67	67	65	<b>29</b>	<b>21</b>	74	69	68	70	70	68	<b>32</b>	<b>25</b>
	750 (354)	0.001 (0.4)	66	61	57	55	54	52	<b>18</b>	<b>&lt;15</b>	67	62	58	57	56	54	<b>19</b>	<b>16</b>	69	64	60	59	58	56	<b>21</b>	<b>19</b>
524 24x16 inches	1100 (519)	0.006 (1.5)	67	62	59	57	56	53	<b>19</b>	<b>&lt;15</b>	68	63	60	59	58	55	<b>20</b>	<b>18</b>	70	65	62	61	60	57	<b>22</b>	<b>20</b>
	1500 (708)	0.010 (2.6)	69	64	61	59	58	55	<b>21</b>	<b>17</b>	70	65	62	61	60	57	<b>22</b>	<b>20</b>	72	67	64	63	62	59	<b>25</b>	<b>22</b>
	2400 (1133)	0.023 (5.7)	72	67	64	62	62	58	<b>25</b>	<b>21</b>	73	68	65	64	64	60	<b>26</b>	<b>24</b>	75	70	67	66	66	62	<b>28</b>	<b>26</b>
	2800 (1321)	0.030 (7.5)	74	69	66	64	64	60	<b>27</b>	<b>23</b>	75	70	67	66	66	62	<b>28</b>	<b>26</b>	77	72	69	68	68	64	<b>31</b>	<b>29</b>
	3600 (1699)	0.045 (11.1)	76	71	68	66	66	62	<b>29</b>	<b>26</b>	77	72	69	68	68	64	<b>31</b>	<b>29</b>	79	74	71	70	70	66	<b>33</b>	<b>31</b>

- NOTE 1:** Performance data contained within a bold border outline are AHRI certified data.
- NOTE 2:** Performance data not contained within a bold border outline are application ratings. Application ratings are outside the scope of the Certification Program.
- NOTE 3:** Performance data is obtained from laboratory testing in accordance with AHRI 880-2011 and ANSI/ASHRAE 130-2008.
- NOTE 4:** NC values are calculated using attenuation credits outlined in Appendix E of AHRI 885-2008.
- NOTE 5:** Discharge Sound power levels shown with End Reflection Corrections Included in dB (ref: 10<sup>-12</sup> watts).
- NOTE 6:** Minimum Ps is the static pressure drop across the air terminal unit while the inlet damper is in the wide-open position at a given airflow rate.

**Table 14: MQTH-500 Minimum Pressures, in.w.g.**

Unit Size	CFM	Unit ΔPs	Unit ΔPt	Unit + 1R Coil, ΔPs	Unit + 1R Coil, ΔPt	Unit + 2R Coil, ΔPs	Unit + 2R Coil, ΔPt	Unit + 3R Coil, ΔPs	Unit + 3R Coil, ΔPt	Unit + 4R Coil, ΔPs	Unit + 4R Coil, ΔPt
504/505 4 & 5 inch	100	0.005	0.020	0.02	0.03	0.04	0.05	0.05	0.06	0.05	0.06
	200	0.020	0.079	0.06	0.12	0.10	0.16	0.14	0.20	0.18	0.24
	300	0.045	0.178	0.12	0.25	0.21	0.34	0.29	0.42	0.37	0.50
	400	0.080	0.316	0.20	0.44	0.34	0.58	0.47	0.71	0.60	0.84
	500	0.125	0.494	0.31	0.67	0.51	0.87	0.69	1.05	0.88	1.24
506 6 inch	600	0.180	0.712	0.39	0.92	0.69	1.22	—	—	—	—
	300	0.001	0.039	0.05	0.09	0.10	0.14	0.16	0.20	0.20	0.24
508 8 inch	400	0.001	0.069	0.08	0.15	0.16	0.23	0.24	0.31	0.32	0.39
	500	0.002	0.108	0.11	0.22	0.23	0.34	0.35	0.46	0.46	0.57
	600	0.003	0.155	0.15	0.30	0.32	0.47	0.47	0.62	0.63	0.78
	700	0.004	0.211	0.19	0.40	0.41	0.62	0.61	0.82	0.82	1.03
	800	0.005	0.275	0.25	0.52	0.52	0.79	0.78	1.05	—	—
	900	0.007	0.348	0.31	0.65	0.63	0.97	—	—	—	—
	1000	0.008	0.430	0.37	0.79	0.75	1.17	—	—	—	—
510 10 inch	400	0.004	0.030	0.04	0.07	0.09	0.12	0.13	0.16	0.17	0.20
	600	0.009	0.068	0.09	0.15	0.18	0.24	0.25	0.31	0.35	0.41
	800	0.016	0.121	0.15	0.25	0.29	0.39	0.37	0.47	0.56	0.66
	1000	0.025	0.189	0.21	0.38	0.41	0.58	0.49	0.66	0.81	0.98
	1200	0.036	0.272	0.29	0.52	0.58	0.81	0.65	0.88	—	—
	1400	0.049	0.370	0.38	0.70	0.78	1.10	—	—	—	—
512 12 inch	1600	0.063	0.483	0.48	0.90	—	—	—	—	—	—
	800	0.020	0.070	0.09	0.14	0.19	0.24	0.26	0.31	0.34	0.39
	1000	0.031	0.110	0.14	0.22	0.27	0.35	0.38	0.46	0.49	0.57
	1200	0.045	0.158	0.20	0.31	0.38	0.49	0.52	0.63	0.68	0.79
	1400	0.061	0.215	0.25	0.41	0.49	0.65	0.67	0.83	0.88	1.04
	1600	0.080	0.281	0.32	0.52	0.59	0.79	0.85	1.05	—	—
	1800	0.101	0.356	0.40	0.66	0.72	0.98	—	—	—	—
514 14 inch	2000	0.125	0.439	0.49	0.80	0.87	1.18	—	—	—	—
	2200	0.151	0.532	0.57	0.95	—	—	—	—	—	—
	1000	0.000	0.044	0.06	0.10	0.12	0.16	0.19	0.23	0.25	0.29
	1300	0.000	0.075	0.09	0.16	0.19	0.26	0.29	0.36	0.38	0.45
	1600	0.001	0.113	0.13	0.24	0.27	0.38	0.41	0.52	0.54	0.65
	2000	0.001	0.177	0.18	0.36	0.39	0.57	0.59	0.77	0.79	0.97
	2300	0.001	0.234	0.24	0.47	0.50	0.73	0.75	0.98	—	—
516 16 inch	2600	0.002	0.299	0.29	0.59	0.61	0.91	—	—	—	—
	3000	0.002	0.398	0.37	0.77	0.78	1.18	—	—	—	—
	3300	0.003	0.482	0.44	0.92	—	—	—	—	—	—
	1600	0.030	0.094	0.12	0.18	0.23	0.29	0.33	0.39	0.45	0.51
	2000	0.044	0.144	0.18	0.28	0.33	0.43	0.48	0.58	0.62	0.72
	2300	0.052	0.185	0.22	0.35	0.42	0.55	0.60	0.73	0.78	0.91
	2600	0.070	0.239	0.28	0.45	0.52	0.69	0.75	0.92	—	—
520 20×16 inches	3000	0.085	0.310	0.36	0.58	0.66	0.88	0.95	1.17	—	—
	3300	0.100	0.373	0.42	0.69	0.77	1.04	—	—	—	—
	3600	0.113	0.438	0.48	0.81	0.89	1.22	—	—	—	—
	4000	0.131	0.532	0.58	0.98	—	—	—	—	—	—
	1500	0.008	0.028	0.05	0.07	0.11	0.13	0.16	0.18	0.21	0.23
	2000	0.013	0.049	0.08	0.12	0.17	0.21	0.25	0.29	0.33	0.37
	2500	0.021	0.077	0.13	0.19	0.25	0.31	0.37	0.43	0.48	0.54
524 24×16 inches	3000	0.030	0.111	0.18	0.26	0.35	0.43	0.50	0.58	0.66	0.74
	3500	0.041	0.151	0.23	0.34	0.45	0.56	0.65	0.76	0.86	0.97
	4000	0.053	0.198	0.29	0.44	0.56	0.71	0.82	0.97	—	—
	5000	0.083	0.309	0.44	0.67	0.82	1.05	—	—	—	—
	6000	0.120	0.445	0.61	0.94	—	—	—	—	—	—
	2000	0.014	0.040	0.06	0.09	0.12	0.15	0.17	0.20	0.23	0.26
	3000	0.031	0.090	0.13	0.19	0.24	0.30	0.35	0.41	0.45	0.51
524 24×16 inches	4000	0.056	0.160	0.22	0.32	0.40	0.50	0.58	0.68	0.75	0.85
	5000	0.087	0.250	0.33	0.49	0.59	0.75	0.84	1.00	—	—
	6000	0.125	0.360	0.45	0.68	0.81	1.04	—	—	—	—
	6500	0.152	0.428	0.52	0.80	—	—	—	—	—	—
	7000	0.173	0.493	0.59	0.91	—	—	—	—	—	—

**NOTE 1:** ΔPs = static pressure drop; ΔPt = total pressure drop.

**NOTE 2:** Calculations of ΔPs and ΔPt were performed using standard air with a density of 0.075 lb m/cu ft.

**NOTE 3:** Data based on testing standard Daikin Applied hot water coils per AHRI Standard 410.

**NOTE 4:** Unit ΔPs and Unit ΔPt are pressure drops across the air terminal unit while the inlet damper is in the wide-open position.

**NOTE 5:** Data applies to air terminal units with hot water coil mounted on the discharge side.

**NOTE 6:** “ — ” is shown when the static pressure drop exceeds 0.50 in.w.g.

**Table 15: MQTH-500 Unit Size 504-506 Hot Water Coils MBH Selection Data – Imperial Units**

Unit Size	Rows	Connection OD (in)	GPM	Head Loss (ft-H <sub>2</sub> O)	CFM							
					100	200	300	350	400	450	500	600
504 505 506	1	0.625	1	0.46	5.1	7.2	8.6	9.1	9.6	10.0	10.3	11.0
			2	1.76	5.4	7.8	9.5	10.1	10.7	11.2	11.7	12.5
			3	3.86	5.5	8.1	9.8	10.5	11.2	11.7	12.2	13.2
			4	6.73	5.6	8.2	10.0	10.7	11.4	12.0	12.6	13.5
				Airside Ps	0.01	0.04	0.07	0.10	0.12	0.15	0.18	0.24
	2	0.875	1	0.12	7.5	11.1	13.4	14.3	15.0	15.7	16.3	17.3
			2	0.46	8.1	12.5	15.5	16.8	17.8	18.8	19.7	21.2
			4	1.75	8.4	13.4	17.0	18.4	19.8	21.0	22.1	24.1
			6	3.84	8.5	13.7	17.5	19.1	20.6	21.9	23.1	25.2
				Airside Ps	0.03	0.08	0.16	0.21	0.26	0.32	0.38	0.51
	3	0.875	1	0.07	8.9	13.2	15.9	16.8	17.7	18.4	19.0	20.0
			2	0.28	9.6	15.2	19.1	20.6	21.9	23.1	24.1	25.9
			4	1.09	10.0	16.5	21.3	23.2	25.0	26.6	28.0	30.5
			6	2.44	10.2	17.0	22.2	24.3	26.3	28.0	29.7	32.5
				Airside Ps	0.04	0.12	0.24	0.31	0.39	0.47	0.56	0.77
	4	0.875	1	0.05	9.7	14.5	17.4	18.4	19.3	20.1	20.7	21.7
			2	0.20	10.5	17.0	21.4	23.2	24.7	26.0	27.1	29.1
			4	0.79	10.9	18.6	24.2	26.6	28.7	30.6	32.3	35.3
			6	1.77	11.1	19.2	25.3	28.0	30.4	32.5	34.5	38.0
				Airside Ps	0.05	0.16	0.32	0.41	0.52	0.63	0.75	1.02

**NOTE:** Heating capacity data in tables assume an entering water temperature (EWT) of 180°F, and an entering air temperature (EAT) of 65°F, which corresponds to a temperature difference of 115°F. Smaller temperature differences will result in a decrease of heating capacity. To obtain the heating capacity at another temperature difference, refer to the hot water coil notes located in the Reference Section.

**Table 16: MQTH-500 Unit Size 504-506 Hot Water Coils kW Selection Data – Metric Units**

Unit Size	Rows	Connection OD (mm)	Water Flow (L/s)	Head Loss (kPa)	Airflow (L/s)							
					47	94	142	165	189	212	236	283
504 505 506	1	15.9	0.06	1.37	1.5	2.1	2.5	2.7	2.8	2.9	3.0	3.2
			0.13	5.26	1.6	2.3	2.8	3.0	3.1	3.3	3.4	3.7
			0.19	11.54	1.6	2.4	2.9	3.1	3.3	3.4	3.6	3.9
			0.25	20.12	1.6	2.4	2.9	3.1	3.3	3.5	3.7	4.0
				Airside Ps (kPa)	0.00	0.01	0.02	0.02	0.03	0.04	0.04	0.06
	2	22.2	0.06	0.36	2.2	3.3	3.9	4.2	4.4	4.6	4.8	5.1
			0.13	1.37	2.4	3.7	4.5	4.9	5.2	5.5	5.8	6.2
			0.25	5.23	2.5	3.9	5.0	5.4	5.8	6.1	6.5	7.1
			0.38	11.48	2.5	4.0	5.1	5.6	6.0	6.4	6.8	7.4
				Airside Ps (kPa)	0.01	0.02	0.04	0.05	0.06	0.08	0.09	0.13
	3	22.2	0.06	0.21	2.6	3.9	4.7	4.9	5.2	5.4	5.6	5.9
			0.13	0.84	2.8	4.5	5.6	6.0	6.4	6.8	7.1	7.6
			0.25	3.26	2.9	4.8	6.2	6.8	7.3	7.8	8.2	8.9
			0.38	7.29	3.0	5.0	6.5	7.1	7.7	8.2	8.7	9.5
				Airside Ps (kPa)	0.01	0.03	0.06	0.08	0.10	0.12	0.14	0.19
	4	22.2	0.06	0.15	2.8	4.2	5.1	5.4	5.7	5.9	6.1	6.4
			0.13	0.60	3.1	5.0	6.3	6.8	7.2	7.6	7.9	8.5
			0.25	2.36	3.2	5.4	7.1	7.8	8.4	9.0	9.5	10.3
			0.38	5.29	3.3	5.6	7.4	8.2	8.9	9.5	10.1	11.1
				Airside Ps (kPa)	0.01	0.04	0.08	0.10	0.13	0.16	0.19	0.25

**NOTE:** Heating capacity data in tables assume an entering water temperature (EWT) of 82°C, and an entering air temperature (EAT) of 18°C, which corresponds to a temperature difference of 64°C. Smaller temperature differences will result in a decrease of heating capacity. To obtain the heating capacity at another temperature difference, refer to the hot water coil notes located in the Reference Section.



**Table 17: MQTH-500 Unit Size 508 and 510 Hot Water Coils MBH Selection Data – Imperial Units**

Unit Size	Rows	Connection OD (in)	GPM	Head Loss (ft-H <sub>2</sub> O)	CFM							
					500	600	700	800	1000	1200	1400	1600
508	1	0.625	1	0.63	12.1	12.9	13.5	14.1	15.1	15.9	16.5	17.1
			2	2.39	13.7	14.7	15.6	16.4	17.7	18.8	19.7	20.5
			3	5.24	14.3	15.4	16.4	17.3	18.8	20.1	21.1	22.1
			4	9.14	14.7	15.9	16.9	17.9	19.5	20.8	21.9	22.9
			Airsides Ps		0.11	0.15	0.19	0.24	0.36	0.49	0.64	0.81
	2	0.875	1	0.17	18.6	19.8	20.9	21.7	22.5	23.1	25.1	—
			2	0.63	22.5	24.3	25.9	27.3	28.5	29.6	33.0	—
			4	2.39	25.1	27.5	29.6	31.5	33.1	34.6	39.4	—
			6	5.22	26.2	28.8	31.1	33.2	35.1	36.7	42.2	—
			Airsides Ps		0.23	0.32	0.41	0.51	0.62	0.74	1.31	—
	3	0.875	1	0.08	21.8	23.1	24.1	25.0	26.3	27.3	—	—
			2	0.31	27.5	29.8	31.6	33.2	35.8	37.8	—	—
			4	1.21	31.7	34.8	37.5	39.9	43.8	47.0	—	—
			8	4.78	34.3	38.1	41.5	44.4	49.5	53.8	—	—
			Airsides Ps		0.35	0.47	0.61	0.77	1.11	1.51	—	—
	4	0.875	2	0.21	30.9	33.4	35.4	37.1	39.9	—	—	—
4			0.84	36.3	40.0	43.1	45.9	50.5	—	—	—	
6			1.87	38.5	42.8	46.5	49.8	55.4	—	—	—	
8			3.32	39.8	44.4	48.5	52.1	58.3	—	—	—	
Airsides Ps			0.46	0.63	0.82	1.02	1.49	—	—	—		
510	1	0.625	1	0.11	13.4	14.3	15.0	15.6	16.7	17.5	18.2	18.7
			2	0.43	15.7	16.9	17.9	18.8	20.4	21.6	22.7	23.6
			4	1.63	17.2	18.6	19.9	21.1	23.0	24.7	26.0	27.3
			6	3.58	17.8	19.3	20.7	22.0	24.1	25.9	27.5	28.8
			Airsides Ps		0.06	0.08	0.10	0.13	0.19	0.25	0.33	0.42
	2	0.875	1	0.36	20.5	21.9	23.0	24.0	25.5	26.7	27.7	28.5
			2	1.43	25.2	27.4	29.3	30.9	33.6	35.8	37.6	39.1
			3	3.20	27.3	29.9	32.2	34.2	37.6	40.4	42.8	44.8
			4	5.68	28.5	31.4	34.0	36.2	40.0	43.2	46.0	48.3
			Airsides Ps		0.12	0.17	0.22	0.27	0.39	0.54	0.69	0.87
	3	0.875	1	0.24	23.7	25.1	26.2	27.1	28.6	29.6	30.4	31.1
			2	0.94	30.4	33.0	35.1	36.9	39.9	42.2	44.0	45.5
			4	3.79	35.3	39.0	42.2	45.0	49.8	53.6	56.8	59.6
			6	8.53	37.3	41.6	45.3	48.6	54.3	59.0	63.0	66.5
			Airsides Ps		0.19	0.25	0.33	0.41	0.59	0.80	1.04	1.30
	4	0.875	2	0.83	34.3	37.3	39.7	41.7	45.0	47.5	49.5	—
4			3.35	40.3	44.7	48.6	51.9	57.5	62.0	65.8	—	
6			7.54	42.7	47.9	52.4	56.5	63.4	69.1	73.9	—	
8			13.41	44.0	49.6	54.6	59.0	66.8	73.2	78.8	—	
Airsides Ps			0.25	0.34	0.43	0.54	0.79	1.07	1.39	—		

**NOTE:** Heating capacity data in tables assume an entering water temperature (EWT) of 180°F, and an entering air temperature (EAT) of 65°F, which corresponds to a temperature difference of 115°F. Smaller temperature differences will result in a decrease of heating capacity. To obtain the heating capacity at another temperature difference, refer to the hot water coil notes located in the Reference Section.

**Table 18: MQTH-500 Unit Size 508 and 510 Hot Water Coils kW Selection Data – Metric Units**

Unit Size	Rows	Connection OD (mm)	Water Flow (L/s)	Head Loss (kPa)	Airflow (L/s)								
					236	283	330	378	472	566	661	755	
508	1	15.9	0.06	1.88	3.5	3.8	4.0	4.1	4.4	4.7	4.8	5.0	
			0.13	7.14	4.0	4.3	4.6	4.8	5.2	5.5	5.8	6.0	
			0.19	15.66	4.2	4.5	4.8	5.1	5.5	5.9	6.2	6.5	
			0.25	27.32	4.3	4.7	4.9	5.2	5.7	6.1	6.4	6.7	
				Airside Ps (kPa)		0.03	0.04	0.05	0.06	0.09	0.12	0.16	0.20
	2	22.2	0.06	0.51	5.4	5.8	6.1	6.4	6.6	6.8	7.3	—	
			0.13	1.88	6.6	7.1	7.6	8.0	8.3	8.7	9.7	—	
			0.25	7.14	7.3	8.1	8.7	9.2	9.7	10.1	11.5	—	
			0.38	15.60	7.7	8.4	9.1	9.7	10.3	10.7	12.4	—	
				Airside Ps (kPa)		0.06	0.08	0.10	0.13	0.15	0.18	0.33	—
	3	22.2	0.06	0.24	6.4	6.8	7.1	7.3	7.7	8.0	—	—	
			0.13	0.93	8.1	8.7	9.3	9.7	10.5	11.1	—	—	
			0.25	3.62	9.3	10.2	11.0	11.7	12.8	13.8	—	—	
			0.50	14.29	10.0	11.2	12.2	13.0	14.5	15.8	—	—	
				Airside Ps (kPa)		0.09	0.12	0.15	0.19	0.28	0.38	—	—
	4	22.2	0.13	0.63	9.0	9.8	10.4	10.9	11.7	—	—	—	
0.25			2.51	10.6	11.7	12.6	13.4	14.8	—	—	—		
0.38			5.59	11.3	12.5	13.6	14.6	16.2	—	—	—		
0.50			9.92	11.7	13.0	14.2	15.3	17.1	—	—	—		
			Airside Ps (kPa)		0.11	0.16	0.20	0.25	0.37	—	—	—	
510	1	15.9	0.06	0.33	3.9	4.2	4.4	4.6	4.9	5.1	5.3	5.5	
			0.13	1.29	4.6	4.9	5.2	5.5	6.0	6.3	6.6	6.9	
			0.25	4.87	5.0	5.4	5.8	6.2	6.7	7.2	7.6	8.0	
			0.38	10.70	5.2	5.7	6.1	6.4	7.1	7.6	8.1	8.4	
				Airside Ps (kPa)		0.01	0.02	0.02	0.03	0.05	0.06	0.08	0.10
	2	22.2	0.06	1.08	6.0	6.4	6.7	7.0	7.5	7.8	8.1	8.3	
			0.13	4.27	7.4	8.0	8.6	9.0	9.8	10.5	11.0	11.4	
			0.19	9.56	8.0	8.8	9.4	10.0	11.0	11.8	12.5	13.1	
			0.25	16.98	8.3	9.2	10.0	10.6	11.7	12.6	13.5	14.1	
				Airside Ps (kPa)		0.03	0.04	0.05	0.07	0.10	0.13	0.17	0.22
	3	22.2	0.06	0.72	6.9	7.3	7.7	7.9	8.4	8.7	8.9	9.1	
			0.13	2.81	8.9	9.7	10.3	10.8	11.7	12.4	12.9	13.3	
			0.25	11.33	10.3	11.4	12.4	13.2	14.6	15.7	16.6	17.5	
			0.38	25.5	10.9	12.2	13.3	14.2	15.9	17.3	18.4	19.5	
				Airside Ps (kPa)		0.05	0.06	0.08	0.10	0.15	0.20	0.26	0.32
	4	22.2	0.13	2.48	10.0	10.9	11.6	12.2	13.2	13.9	14.5	—	
0.25			10.01	11.8	13.1	14.2	15.2	16.8	18.2	19.3	—		
0.38			22.54	12.5	14.0	15.3	16.5	18.6	20.2	21.6	—		
0.50			40.08	12.9	14.5	16.0	17.3	19.6	21.4	23.1	—		
			Airside Ps (kPa)		0.06	0.08	0.11	0.13	0.20	0.27	0.35	—	

**NOTE:** Heating capacity data in tables assume an entering water temperature (EWT) of 82°C, and an entering air temperature (EAT) of 18°C, which corresponds to a temperature difference of 64°C. Smaller temperature differences will result in a decrease of heating capacity. To obtain the heating capacity at another temperature difference, refer to the hot water coil notes located in the Reference Section.

**Table 19: MQTH-500 Unit Size 512 Hot Water Coils MBH Selection Data – Imperial Units**

Unit Size	Rows	Connection OD (in)	GPM	Head Loss (ft-H <sub>2</sub> O)	CFM							
					800	1000	1200	1400	1600	1800	2000	2200
512	1	0.875	2	0.54	22.2	24.1	25.7	27.1	28.2	29.3	30.2	31.0
			4	2.07	24.8	27.3	29.4	31.2	32.7	34.1	35.4	36.5
			6	4.53	25.9	28.6	30.9	32.9	34.6	36.2	37.6	38.9
			8	7.90	26.5	29.3	31.7	33.8	35.7	37.4	38.9	40.3
			Airsides Ps		0.07	0.11	0.15	0.19	0.24	0.30	0.36	0.42
	2	0.875	2	0.33	34.1	37.2	39.7	41.7	43.4	46.2	47.3	48.4
			4	1.30	40.4	44.9	48.7	51.8	54.6	59.2	61.2	62.9
			6	2.89	43.1	48.3	52.7	56.5	59.9	65.5	67.9	70.1
			8	5.10	44.6	50.3	55.1	59.2	62.9	69.2	71.9	74.4
			Airsides Ps		0.16	0.23	0.32	0.41	0.51	0.74	0.87	1.01
	3	0.875	2	0.23	42.4	46.0	48.9	51.2	53.1	54.7	56.1	57.3
			4	0.90	51.3	57.2	62.0	66.1	69.6	72.6	75.2	77.6
			8	3.55	57.2	64.9	71.5	77.2	82.2	86.7	90.7	94.3
			12	7.95	59.5	68.0	75.4	81.8	87.6	92.7	97.4	101.6
			Airsides Ps		0.24	0.35	0.47	0.61	0.77	0.93	1.11	1.31
	4	0.875	2	0.42	47.6	51.6	54.7	57.2	59.2	60.9	62.3	—
			4	0.73	58.6	65.6	71.2	76.0	79.7	83.4	86.4	—
			8	2.89	65.9	75.3	83.4	90.4	96.5	101.9	106.7	—
			12	6.47	68.7	79.2	88.4	96.4	103.5	110.0	115.8	—
			Airsides Ps		0.32	0.46	0.63	0.82	1.02	1.25	1.49	—

**NOTE:** Heating capacity data in tables assume an entering water temperature (EWT) of 180°F, and an entering air temperature (EAT) of 65°F, which corresponds to a temperature difference of 115°F. Smaller temperature differences will result in a decrease of heating capacity. To obtain the heating capacity at another temperature difference, refer to the hot water coil notes located in the Reference Section.

**Table 20: MQTH-500 Unit Size 512 Hot Water Coils kW Selection Data – Metric Units**

Unit Size	Rows	Connection OD (mm)	Water Flow (L/s)	Head Loss (kPa)	Airflow (L/s)							
					378	472	566	661	755	850	944	1038
512	1	22.2	0.13	1.61	6.5	7.1	7.5	7.9	8.3	8.6	8.8	9.1
			0.25	6.19	7.3	8.0	8.6	9.1	9.6	10.0	10.4	10.7
			0.38	13.54	7.6	8.4	9.0	9.6	10.1	10.6	11.0	11.4
			0.50	23.61	7.8	8.6	9.3	9.9	10.5	11.0	11.4	11.8
			Airsides Ps (kPa)		0.02	0.03	0.04	0.05	0.06	0.07	0.09	0.10
	2	22.2	0.13	0.99	10.0	10.9	11.6	12.2	12.7	13.5	13.8	14.2
			0.25	3.89	11.8	13.1	14.3	15.2	16.0	17.3	17.9	18.4
			0.38	8.64	12.6	14.1	15.4	16.5	17.5	19.2	19.9	20.5
			0.50	15.24	13.1	14.7	16.1	17.3	18.4	20.3	21.1	21.8
			Airsides Ps (kPa)		0.04	0.06	0.08	0.10	0.13	0.18	0.22	0.25
	3	22.2	0.13	0.69	12.4	13.5	14.3	15.0	15.5	16.0	16.4	16.8
			0.25	2.69	15.0	16.7	18.2	19.4	20.4	21.3	22.0	22.7
			0.50	10.61	16.7	19.0	20.9	22.6	24.1	25.4	26.6	27.6
			0.76	23.76	17.4	19.9	22.1	24.0	25.6	27.1	28.5	29.7
			Airsides Ps (kPa)		0.06	0.09	0.12	0.15	0.19	0.23	0.28	0.33
	4	22.2	0.13	1.26	13.9	15.1	16.0	16.7	17.3	17.8	18.2	—
			0.25	2.18	17.2	19.2	20.8	22.3	23.3	24.4	25.3	—
			0.50	8.64	19.3	22.0	24.4	26.5	28.3	29.8	31.2	—
			0.76	19.34	20.1	23.2	25.9	28.2	30.3	32.2	33.9	—
			Airsides Ps (kPa)		0.08	0.11	0.16	0.20	0.25	0.31	0.37	—

**NOTE:** Heating capacity data in tables assume an entering water temperature (EWT) of 82°C, and an entering air temperature (EAT) of 18°C, which corresponds to a temperature difference of 64°C. Smaller temperature differences will result in a decrease of heating capacity. To obtain the heating capacity at another temperature difference, refer to the hot water coil notes located in the Reference Section.

**Table 21: MQTH-500 Unit Size 514 Hot Water Coils MBH Selection Data – Imperial Units**

Unit Size	Rows	Connection OD (in)	GPM	Head Loss (ft-H <sub>2</sub> O)	CFM							
					600	700	800	1000	1500	2000	2500	3000
514	1	0.625	1	0.20	19.8	21.9	22.7	23.5	26.3	28.2	29.5	30.6
			2	0.74	23.4	26.6	27.9	29.1	33.6	36.9	39.3	41.3
			3	3.36	25.9	29.8	31.4	33.0	37.1	41.1	44.2	46.8
			4	6.17	26.8	31.1	32.9	34.6	39.1	43.6	47.1	50.1
			Airsides Ps		0.02	0.04	0.05	0.06	0.11	0.19	0.27	0.37
	2	0.875	2	0.39	34.4	39.4	41.4	43.3	50.1	54.7	58.0	60.6
			4	1.52	39.7	46.6	49.6	52.3	63.0	70.7	76.6	81.4
			6	3.36	41.8	49.7	53.1	56.2	68.9	78.4	85.8	91.9
			8	5.84	43.0	47.4	51.3	58.4	72.3	82.9	91.3	98.2
			Airsides Ps		0.05	0.09	0.10	0.12	0.24	0.39	0.57	0.78
	3	0.875	2	0.25	42.8	46.1	48.9	53.5	61.2	66.0	69.4	71.8
			6	2.20	52.1	57.6	62.7	71.5	88.5	100.8	110.3	117.9
			8	3.89	53.4	59.4	64.8	74.5	93.4	107.6	118.7	127.8
			10	6.05	54.3	60.5	66.2	76.3	96.6	112.1	124.4	134.5
			Airsides Ps		0.08	0.10	0.13	0.19	0.37	0.59	0.86	1.17
	4	0.875	4	0.78	55.4	61.2	66.3	75.0	90.9	101.7	109.5	115.5
			6	1.26	58.3	64.9	71.0	81.6	101.9	116.5	127.5	136.3
			8	3.08	59.8	66.9	73.5	85.2	108.2	125.3	138.6	149.4
			12	6.89	61.3	69.0	76.1	89.0	115.1	135.3	151.6	165.0
			Airsides Ps		0.11	0.14	0.17	0.25	0.49	0.79	1.15	1.56

**NOTE:** Heating capacity data in tables assume an entering water temperature (EWT) of 180°F, and an entering air temperature (EAT) of 65°F, which corresponds to a temperature difference of 115°F. Smaller temperature differences will result in a decrease of heating capacity. To obtain the heating capacity at another temperature difference, refer to the hot water coil notes located in the Reference Section.

**Table 22: MQTH-500 Unit Size 514 Hot Water Coils kW Selection Data – Metric Units**

Unit Size	Rows	Connection OD (mm)	Water Flow (L/s)	Head Loss (kPa)	Airflow (L/s)							
					283	330	378	472	708	944	1180	1416
514	1	15.9	0.06	0.60	5.8	6.4	6.6	6.9	7.7	8.3	8.6	9.0
			0.13	2.21	6.9	7.8	8.2	8.5	9.8	10.8	11.5	12.1
			0.19	10.04	7.6	8.7	9.2	9.7	10.9	12.0	12.9	13.7
			0.25	18.44	7.8	9.1	9.6	10.1	11.4	12.8	13.8	14.7
			Airsides Ps (kPa)		0.00	0.01	0.01	0.01	0.03	0.05	0.07	0.09
	2	22.2	0.13	1.17	10.1	11.5	12.1	12.7	14.7	16.0	17.0	17.7
			0.25	4.54	11.6	13.6	14.5	15.3	18.4	20.7	22.4	23.8
			0.38	10.04	12.2	14.6	15.5	16.5	20.2	23.0	25.1	26.9
			0.50	17.46	12.6	13.9	15.0	17.1	21.2	24.3	26.7	28.8
			Airsides Ps (kPa)		0.01	0.02	0.02	0.03	0.06	0.10	0.14	0.19
	3	22.2	0.13	0.75	12.5	13.5	14.3	15.7	17.9	19.3	20.3	21.0
			0.38	6.58	15.3	16.9	18.4	20.9	25.9	29.5	32.3	34.5
			0.50	11.63	15.6	17.4	19.0	21.8	27.3	31.5	34.8	37.4
			0.63	18.08	15.9	17.7	19.4	22.3	28.3	32.8	36.4	39.4
			Airsides Ps (kPa)		0.02	0.02	0.03	0.05	0.09	0.15	0.21	0.29
	4	22.2	0.25	2.33	16.2	17.9	19.4	22.0	26.6	29.8	32.1	33.8
			0.38	3.77	17.1	19.0	20.8	23.9	29.8	34.1	37.3	39.9
			0.50	9.21	17.5	19.6	21.5	24.9	31.7	36.7	40.6	43.7
			0.76	20.59	17.9	20.2	22.3	26.1	33.7	39.6	44.4	48.3
			Airsides Ps (kPa)		0.03	0.03	0.04	0.06	0.12	0.20	0.29	0.39

**NOTE:** Heating capacity data in tables assume an entering water temperature (EWT) of 82°C, and an entering air temperature (EAT) of 18°C, which corresponds to a temperature difference of 64°C. Smaller temperature differences will result in a decrease of heating capacity. To obtain the heating capacity at another temperature difference, refer to the hot water coil notes located in the Reference Section.

**Table 23: MQTH-500 Unit Size 516 Hot Water Coils MBH Selection Data – Imperial Units**

Unit Size	Rows	Connection OD (in)	GPM	Head Loss (ft-H <sub>2</sub> O)	CFM							
					1000	1500	2000	2500	3000	3500	4000	4200
516	1	0.625	1	0.23	25.4	28.5	30.5	32.0	33.2	34.1	34.8	35.1
			2	0.86	31.6	36.7	40.3	43.1	45.3	47.1	48.7	49.2
			4	3.25	35.9	42.8	47.9	51.9	55.3	58.1	60.5	61.4
			6	7.12	37.6	45.3	51.1	55.8	59.7	63.0	65.9	66.9
			Airsides Ps		0.04	0.08	0.14	0.20	0.27	0.36	0.45	0.49
	2	0.875	2	0.41	46.2	53.7	58.8	62.4	65.2	67.5	69.3	69.9
			4	1.59	55.8	67.8	76.4	83.0	88.4	92.7	96.5	97.8
			6	2.52	60.0	74.2	84.8	93.1	100.0	105.8	110.8	112.6
			8	6.21	62.3	77.9	89.7	99.2	107.1	113.8	119.6	121.7
			Airsides Ps		0.09	0.18	0.29	0.42	0.57	0.74	0.93	1.01
	3	0.875	2	0.26	57.1	65.5	70.8	74.4	77.0	79.1	80.7	81.3
			4	1.03	70.4	85.7	96.3	104.2	110.3	115.3	119.4	120.8
			8	4.06	78.9	100.0	115.9	128.5	138.8	147.4	141.1	157.5
			10	6.31	80.8	103.4	120.7	134.6	146.1	155.9	154.8	167.4
			Airsides Ps		0.14	0.27	0.44	0.63	0.86	1.11	1.40	1.51
	4	0.875	2	0.20	63.2	72.1	77.5	81.0	83.5	85.5	—	—
			4	0.80	79.5	97.1	109.1	117.8	124.4	129.7	—	—
			8	1.80	86.1	115.1	134.3	149.3	161.4	171.5	—	—
			10	4.95	91.8	119.3	140.4	157.3	171.2	182.8	—	—
			Airsides Ps		0.18	0.36	0.58	0.84	1.15	1.49	—	—

**NOTE:** Heating capacity data in tables assume an entering water temperature (EWT) of 180°F, and an entering air temperature (EAT) of 65°F, which corresponds to a temperature difference of 115°F. Smaller temperature differences will result in a decrease of heating capacity. To obtain the heating capacity at another temperature difference, refer to the hot water coil notes located in the Reference Section.

**Table 24: MQTH-500 Unit Size 516 Hot Water Coils kW Selection Data – Metric Units**

Unit Size	Rows	Connection OD (mm)	Water Flow (L/s)	Head Loss (kPa)	Airflow (L/s)							
					472	708	944	1180	1416	1652	1888	1982
516	1	15.9	0.06	0.69	7.4	8.3	8.9	9.4	9.7	10.0	10.2	10.3
			0.13	2.57	9.3	10.7	11.8	12.6	13.3	13.8	14.3	14.4
			0.25	9.71	10.5	12.5	14.0	15.2	16.2	17.0	17.7	18.0
			0.38	21.28	11.0	13.3	15.0	16.3	17.5	18.4	19.3	19.6
			Airsides Ps (kPa)		0.01	0.02	0.03	0.05	0.07	0.09	0.11	0.12
	2	22.2	0.13	1.23	13.5	15.7	17.2	18.3	19.1	19.8	20.3	20.5
			0.25	4.75	16.3	19.9	22.4	24.3	25.9	27.1	28.3	28.6
			0.38	7.53	17.6	21.7	24.8	27.3	29.3	31.0	32.4	33.0
			0.50	18.56	18.2	22.8	26.3	29.0	31.4	33.3	35.0	35.6
			Airsides Ps (kPa)		0.02	0.04	0.07	0.10	0.14	0.18	0.23	0.25
	3	22.2	0.13	0.78	16.7	19.2	20.7	21.8	22.5	23.2	23.6	23.8
			0.25	3.08	20.6	25.1	28.2	30.5	32.3	33.8	35.0	35.4
			0.50	12.14	23.1	29.3	33.9	37.6	40.6	43.2	41.3	46.1
			0.63	18.86	23.7	30.3	35.3	39.4	42.8	45.6	45.3	49.0
			Airsides Ps (kPa)		0.03	0.07	0.11	0.16	0.21	0.28	0.35	0.38
	4	22.2	0.13	0.60	18.5	21.1	22.7	23.7	24.4	25.0	—	—
			0.25	2.39	23.3	28.4	31.9	34.5	36.4	38.0	—	—
			0.50	5.38	25.2	33.7	39.3	43.7	47.3	50.2	—	—
			0.63	14.80	26.9	34.9	41.1	46.1	50.1	53.5	—	—
			Airsides Ps (kPa)		0.04	0.09	0.14	0.21	0.29	0.37	—	—

**NOTE:** Heating capacity data in tables assume an entering water temperature (EWT) of 82°C, and an entering air temperature (EAT) of 18°C, which corresponds to a temperature difference of 64°C. Smaller temperature differences will result in a decrease of heating capacity. To obtain the heating capacity at another temperature difference, refer to the hot water coil notes located in the Reference Section.

**Table 25: MQTH-500 Unit Size 520 Hot Water Coils MBH Selection Data – Imperial Units**

Unit Size	Rows	Connection OD (in)	GPM	Head Loss (ft-H <sub>2</sub> O)	CFM							
					2000	2500	3000	3500	4000	4500	5000	5500
520	1	0.875	2	0.33	43.8	46.7	49.0	50.9	52.4	53.8	54.9	55.9
			4	1.30	54.0	58.5	62.3	65.4	68.1	70.5	72.6	74.4
			6	2.89	58.6	64.0	68.5	72.4	75.7	78.7	81.3	83.7
			8	5.10	61.2	67.2	72.2	76.5	80.2	83.6	86.6	89.3
			Airside Ps		0.07	0.11	0.15	0.19	0.24	0.30	0.36	0.42
	2	0.875	2	0.56	63.3	67.2	70.2	72.5	74.4	75.9	77.3	78.4
			4	1.12	84.3	91.8	97.8	102.7	106.9	110.4	113.5	116.2
			8	3.89	100.7	111.9	121.3	129.2	136.0	142.1	147.4	152.2
			10	6.05	104.8	117.1	127.3	136.2	143.9	150.7	156.8	162.2
			Airside Ps		0.16	0.23	0.32	0.41	0.51	0.62	0.74	0.87
	3	1.125	4	0.44	97.4	106.1	112.9	118.5	123.1	127.1	130.5	133.4
			6	0.97	109.4	121.1	130.6	138.5	145.3	151.2	156.3	160.8
			8	1.71	116.3	130.0	141.3	151.0	159.3	166.5	173.0	178.7
			12	3.79	124.1	140.1	153.7	165.5	175.8	185.0	193.2	200.7
			Airside Ps		0.19	0.29	0.40	0.52	0.66	0.81	0.97	1.15
	4	1.125	6	0.62	124.6	137.8	148.3	157.0	164.3	170.5	175.8	180.6
			10	1.70	139.8	157.5	172.4	184.9	195.8	205.3	213.8	221.3
			14	3.31	147.2	167.5	184.8	199.7	212.8	224.4	234.9	244.3
			18	5.44	151.6	173.5	192.3	208.8	223.4	236.5	248.3	259.0
			Airside Ps		0.26	0.38	0.53	0.69	0.88	1.08	1.29	1.53

**NOTE:** Heating capacity data in tables assume an entering water temperature (EWT) of 180°F, and an entering air temperature (EAT) of 65°F, which corresponds to a temperature difference of 115°F. Smaller temperature differences will result in a decrease of heating capacity. To obtain the heating capacity at another temperature difference, refer to the hot water coil notes located in the Reference Section.

**Table 26: MQTH-500 Unit Size 520 Hot Water Coils kW Selection Data – Metric Units**

Unit Size	Rows	Connection OD (mm)	Water Flow (L/s)	Head Loss (kPa)	Airflow (L/s)							
					944	1180	1416	1652	1888	2124	2360	2596
520	1	22.2	0.13	0.99	12.8	13.7	14.3	14.9	15.3	15.8	16.1	16.4
			0.25	3.89	15.8	17.1	18.2	19.1	19.9	20.6	21.3	21.8
			0.38	8.64	17.2	18.7	20.1	21.2	22.2	23.0	23.8	24.5
			0.50	15.24	17.9	19.7	21.1	22.4	23.5	24.5	25.4	26.1
			Airside Ps (kPa)		0.02	0.03	0.04	0.05	0.06	0.07	0.09	0.10
	2	22.2	0.13	1.67	18.5	19.7	20.6	21.2	21.8	22.2	22.6	23.0
			0.25	3.35	24.7	26.9	28.6	30.1	31.3	32.3	33.2	34.0
			0.50	11.63	29.5	32.8	35.5	37.8	39.8	41.6	43.2	44.6
			0.63	18.08	30.7	34.3	37.3	39.9	42.1	44.1	45.9	47.5
			Airside Ps (kPa)		0.04	0.06	0.08	0.10	0.13	0.15	0.18	0.22
	3	28.6	0.25	1.32	28.5	31.1	33.1	34.7	36.0	37.2	38.2	39.1
			0.38	2.90	32.0	35.5	38.2	40.6	42.5	44.3	45.8	47.1
			0.50	5.11	34.1	38.1	41.4	44.2	46.6	48.8	50.7	52.3
			0.76	11.33	36.3	41.0	45.0	48.5	51.5	54.2	56.6	58.8
			Airside Ps (kPa)		0.05	0.07	0.10	0.13	0.16	0.20	0.24	0.29
	4	28.6	0.38	1.85	36.5	40.3	43.4	46.0	48.1	49.9	51.5	52.9
			0.63	5.08	40.9	46.1	50.5	54.1	57.3	60.1	62.6	64.8
			0.88	9.89	43.1	49.0	54.1	58.5	62.3	65.7	68.8	71.5
			1.14	16.26	44.4	50.8	56.3	61.1	65.4	69.2	72.7	75.8
			Airside Ps (kPa)		0.06	0.09	0.13	0.17	0.22	0.27	0.32	0.38

**NOTE:** Heating capacity data in tables assume an entering water temperature (EWT) of 82°C, and an entering air temperature (EAT) of 18°C, which corresponds to a temperature difference of 64°C. Smaller temperature differences will result in a decrease of heating capacity. To obtain the heating capacity at another temperature difference, refer to the hot water coil notes located in the Reference Section.

**Table 27: MQTH-500 Unit Size 524 Hot Water Coils MBH Selection Data – Imperial Units**

Unit Size	Rows	Connection OD (in)	GPM	Head Loss (ft-H <sub>2</sub> O)	CFM							
					2000	2500	3000	3500	4000	5000	6000	7000
524	1	0.875	2	0.36	48.7	52.0	54.6	56.7	58.5	61.3	63.5	65.3
			4	1.41	60.3	65.7	70.0	73.7	76.8	82.0	86.2	89.6
			6	3.13	65.6	71.9	77.2	81.8	85.7	92.3	97.7	102.3
			8	5.52	68.5	75.6	81.4	86.6	91.0	98.6	104.8	110.0
			Airsides Ps		0.05	0.07	0.10	0.13	0.16	0.24	0.32	0.42
	2	0.875	2	0.27	68.4	72.7	75.9	78.4	80.5	83.6	85.9	87.6
			4	1.05	91.7	100.2	107.0	112.6	117.3	124.8	130.6	135.2
			8	4.15	109.9	122.7	133.4	142.6	150.5	163.8	174.4	183.2
			10	6.45	114.3	128.4	140.2	150.5	159.4	174.5	186.7	197.0
			Airsides Ps		0.11	0.16	0.21	0.27	0.34	0.50	0.68	0.88
	3	1.125	3	0.28	94.7	102.0	107.6	112.0	115.6	121.1	125.1	128.2
			6	1.07	118.8	132.0	142.9	151.9	159.6	172.0	181.7	189.6
			10	2.92	131.1	148.2	162.7	175.2	186.0	204.3	219.0	231.3
			15	6.46	138.0	157.5	174.3	189.1	202.2	224.5	243.1	258.8
			Airsides Ps		0.13	0.19	0.26	0.34	0.43	0.64	0.88	1.16
	4	1.125	4	0.29	117.9	128.3	136.3	142.6	147.7	155.5	161.3	165.7
			8	1.16	144.4	162.4	177.2	189.7	200.3	217.6	231.2	242.1
			12	2.58	155.0	176.8	195.4	211.3	225.3	248.6	267.5	283.2
			18	5.76	162.7	187.5	209.1	228.0	244.9	273.7	297.6	317.9
			Airsides Ps		0.17	0.25	0.35	0.46	0.58	0.86	1.18	1.54

**NOTE:** Heating capacity data in tables assume an entering water temperature (EWT) of 180°F, and an entering air temperature (EAT) of 65°F, which corresponds to a temperature difference of 115°F. Smaller temperature differences will result in a decrease of heating capacity. To obtain the heating capacity at another temperature difference, refer to the hot water coil notes located in the Reference Section.

**Table 28: MQTH-500 Unit Size 524 Hot Water Coils kW Selection Data – Metric Units**

Unit Size	Rows	Connection OD (mm)	Water Flow (L/s)	Head Loss (kPa)	Airflow (L/s)							
					944	1180	1416	1652	1888	2360	2832	3304
524	1	22.2	0.13	1.08	14.3	15.2	16.0	16.6	17.1	17.9	18.6	19.1
			0.25	4.21	17.7	19.2	20.5	21.6	22.5	24.0	25.2	26.2
			0.38	9.36	19.2	21.1	22.6	24.0	25.1	27.0	28.6	30.0
			0.50	16.50	20.1	22.1	23.8	25.4	26.6	28.9	30.7	32.2
			Airsides Ps (kPa)		0.01	0.02	0.02	0.03	0.04	0.06	0.08	0.10
	2	22.2	0.13	0.81	20.0	21.3	22.2	23.0	23.6	24.5	25.2	25.6
			0.25	3.14	26.8	29.3	31.3	33.0	34.3	36.5	38.2	39.6
			0.50	12.40	32.2	35.9	39.1	41.8	44.1	48.0	51.1	53.6
			0.63	19.28	33.5	37.6	41.1	44.1	46.7	51.1	54.7	57.7
			Airsides Ps (kPa)		0.03	0.04	0.05	0.07	0.08	0.12	0.17	0.22
	3	28.6	0.19	0.84	27.7	29.9	31.5	32.8	33.8	35.5	36.6	37.5
			0.38	3.20	34.8	38.6	41.8	44.5	46.7	50.4	53.2	55.5
			0.63	8.73	38.4	43.4	47.6	51.3	54.5	59.8	64.1	67.7
			0.95	19.31	40.4	46.1	51.0	55.4	59.2	65.7	71.2	75.8
			Airsides Ps (kPa)		0.03	0.05	0.06	0.08	0.11	0.16	0.22	0.29
	4	28.6	0.25	0.87	34.5	37.6	39.9	41.8	43.2	45.5	47.2	48.5
			0.50	3.47	42.3	47.6	51.9	55.5	58.6	63.7	67.7	70.9
			0.76	7.71	45.4	51.8	57.2	61.9	66.0	72.8	78.3	82.9
			1.14	17.22	47.6	54.9	61.2	66.8	71.7	80.1	87.1	93.1
			Airsides Ps (kPa)		0.04	0.06	0.09	0.11	0.14	0.21	0.29	0.38

**NOTE:** Heating capacity data in tables assume an entering water temperature (EWT) of 82°C, and an entering air temperature (EAT) of 18°C, which corresponds to a temperature difference of 64°C. Smaller temperature differences will result in a decrease of heating capacity. To obtain the heating capacity at another temperature difference, refer to the hot water coil notes located in the Reference Section.

# Accessories and Components

## Hot Water Coils

When ordered with the air terminal, the hot water coil is shipped attached to the discharge of the terminal casing via slip and drive connections. The discharge end of the casing has slip and drive connections for easy connection to downstream ductwork. The hot water coil is constructed of aluminum fin and copper serpentine-type tubes with male sweat connections tested at 300 psig.

Coil selection may be made using Daikin Select Tools selection software. Contact your Daikin Applied representative for a copy. In the interest of energy conservation and due to the possibility of condensation, all hot water coils are marked, "Coil must be externally insulated after installation in the field." Hot water coils are tested in accordance to AHRI. Options, at an additional charge on hot water coils, include access doors for inspection and cleaning, and inlet/outlet on opposite sides of coils.

All accessories which can be attached to the Single Duct Boxes are not a part of the AHRI certification program but ratings can be affected by their use.

## Hot Water Coil Construction Details

Hot water coils are factory mounted on the discharge of the terminal and are available with an optional integral coil access door.



- Coils are enclosed in 20 gauge coated steel casing with slip and drive connection.
- Fins are rippled and sine wave type constructed from heavy gauge aluminum, mechanically bonded to the tubes.
- Tubes are copper with a minimum wall thickness of 0.016" with male solder header connections.
- Coils are leak tested to 300 psig with minimum burst of 2000 psig at ambient temperature.
- Coil performance data is based on tests run in accordance with AHRI standard 410; coils are AHRI certified and include AHRI label.

**Table 29: Coil Connection Size, in (mm)**

MQTH Size	1 Row	2 Row	3 Row	4 Row
504/505/506	5/8" (15.8)	7/8" (22.2)	7/8" (22.2)	7/8" (22.2)
508	5/8" (15.8)	7/8" (22.2)	7/8" (22.2)	7/8" (22.2)
510	5/8" (15.8)	7/8" (22.2)	7/8" (22.2)	7/8" (22.2)
512	7/8" (22.2)	7/8" (22.2)	7/8" (22.2)	7/8" (22.2)
514	5/8" (15.8)	7/8" (22.2)	7/8" (22.2)	7/8" (22.2)
516	5/8" (15.8)	7/8" (22.2)	7/8" (22.2)	7/8" (22.2)
520	7/8" (22.2)	7/8" (22.2)	1-1/8" (28.6)	1-1/8" (28.6)
524	7/8" (22.2)	7/8" (22.2)	1-1/8" (28.6)	1-1/8" (28.6)

**NOTE:** All coils have 10 fins/inch with the exception of 3 & 4 row coils on 20 & 24 boxes which are 8 FPI.

## Electric Heat

Electric heater elements, as illustrated on this page, are integral to the air terminal. Electric heat is controlled via a staged command from a 0-10 vdc signal on the analog output of the unit controller. This signal is sent to the solid state relay which then pulses the voltage for the electric heat. The discharge end has slip and drive connections for easy connection to downstream ductwork. ETL® listed heaters are provided with a fan interlock relay. Heaters that will be controlled electronically must include a 24 VAC control circuit to operate with the low voltage controls on the air terminal. Heater plenums are internally insulated. When an air terminal is ordered with clean room lining and electric heat, the heater plenum is either internally lined with optional foil backed insulation or closed cell foam or may require external insulation in field.

All accessories that can be attached to the Single Duct Boxes are not a part of the AHRI certification program but ratings can be affected by their use.

### Included with each heater assembly:

- Heater and cabinet mounted on the discharge of the MQTH-500
- Discharge plenum with 1/2" fiber face lining
- Air pressure switch
- De-energizing magnetic contactors per step and backup magnetic contactor
- Primary automatic reset high temperature limit (disc type)
- Backup manual reset high temperature limit (disc type)
- Non-isolated transformer
- Slip and drive connections
- Heater is shipped factory mounted and wired

## Electric Heater Assembly Construction Details

Electric reheat coils are factory mounted on the discharge of the air terminal. The heaters are ETL listed for zero clearance, and are tested in accordance with UL Standard 1995, CSA-C22.2 No. 236 and the National Electric Code (NEC). Heater casings are constructed of heavy-duty zinc-coated steel. Element wire is high grade nichrome alloy derated to 45 watts per square inch density. Element wire is supported by moisture-resistant steatite ceramics.

Ceramics are enclosed in reinforcement brackets spaced across the heater element rack at 2" to 4" intervals. Controls are contained in a NEMA 1 control cabinet with a hinged, latching door. A permanent wiring diagram is affixed to the inside of the control cabinet door for field reference.

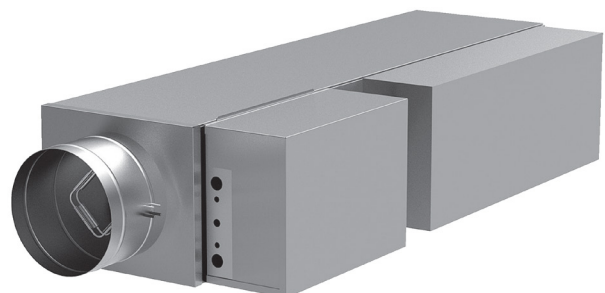



**Table 30: MQTH-500 Single Duct Electric Heater Capacities**

Single Phase					Three Phase kW Limits					
Unit Size	Heater Voltage	Min. kW Step	Max. kW	Max. Steps	Unit Size	Heater Voltage	Min. kW Step	Max. kW	Max. Steps	
504	120	1	4	2	504	208	0.6	4	2	
	208	0.6	4	2		505	240	0.6	4	2
	240	0.6	4	2			506	480	1.6	4
	277	0.6	4	2		508		208	1.6	8
480	1.6	4	2	240	1.6		8	3		
				480	1.6		8	3		
508	120	1	5	3	510	208	1.6	13	3	
	208	0.6	8	3		240	1.6	13	3	
	240	0.6	8	3		480	1.6	15	3	
	277	0.6	8	3	512	208	1.6	16	3	
480	1	8	3	240		1.6	16	3		
				480		1.6	23	3		
510	120	0.6	5	3	514	208	1.6	16	3	
	208	0.6	9.5	3		240	1.6	16	3	
	240	0.6	11	3		480	1.6	24	3	
	277	0.6	12	3	516	208	1.6	16	3	
480	1	15	3	240		1.6	16	3		
				480		1.6	39	3		
512	120	0.6	5	3	520	208	1.6	16	3	
	208	0.6	9.5	3		240	1.6	16	3	
	240	0.6	11	3		480	1.6	39	3	
	277	0.6	12	3	524	208	1.6	16	3	
480	0.6	23	3	240		1.6	16	3		
				480		1.6	39	3		
514	120	0.6	5	3						
	208	0.6	9.5	3						
	240	0.6	11	3						
	277	0.6	12	3						
516	480	0.6	23	3						
	120	1.4	5	3						
	208	0.6	9.5	3						
	240	0.6	11	3						
520	277	0.6	12	3						
	480	0.6	23	3						
	120	0.6	5	3						
	208	0.6	9.5	3						
524	240	0.6	11	3						
	277	0.6	12	3						
	480	0.6	23	3						

**NOTE 1:** Heaters less than 5 kW are specifiable to nearest 0.2 kW. Heaters greater than 5 kW and less than 10 kW are specifiable to nearest 0.5 kW. Heaters greater than 10 kW are specifiable to nearest 1 kW.

**NOTE 2:** Minimum flow rate for electric heat is 70 CFM/kW. Lower CFM's can cause nuisance tripping, excessive discharge temperatures, rapid cycling, and rapid element failure. Electric Heat units running below 70 CFM/kW will void all warranties.

**NOTE 3:** For optimum thermal comfort, the suggested discharge temperature should not exceed 20°F above room set point.

**NOTE 4:** We do not recommend discharge temperatures in excess of 115°F to protect heater coils.

**NOTE 5:** Maximum number of steps at minimum kW is one step.

**NOTE 6:** If more than 1 heater is wired into a building's circuit breaker (multi-outlet branch circuit) each heater will require the addition of power side fusing.

**Electric Heat Selection:**

- A. Specify electric duct heaters using voltage, kW, and number of steps.
- B. Use above chart to select voltage. Calculate required kW using following equations:

$$kW = \frac{BTU}{HR} \div 3413 \quad kW = \frac{CFM \times \Delta \times 1.085}{3413} \quad \Delta = \frac{kW \times 3413}{CFM \times 1.085}$$

$$CFM = \frac{kW \times 3413}{\Delta \times 1.085} \quad CFM = \frac{kW \times 3413}{\Delta \times 1.085}$$

\* Air density at sea level—reduce by 0.036 for each 1000 feet of altitude above sea level

Where: BTU / Hr = Required heating capacity

CFM = volume of air during heating. Typically 100% of maximum cooling air volume

Δ = desired air temperature rise across the electric heater

Inlet air temperature = primary air temperature, usually 55°F

# Introduction

## Fan Powered Terminal Units

Fan powered terminals are typically used for heating and cooling of perimeter zones. Operating cost savings can be achieved through the use of waste heat recovery from the ceiling plenum and from reduced central fan HP. This coupled with a relatively low impact on installation costs are reasons for the widespread application of fan powered terminal units.

Both parallel and series fan powered terminals have a damper to modulate primary cooling air and a fan/motor assembly that draws return air from the ceiling plenum. The difference in the configuration and operation of these terminals is illustrated on these pages.

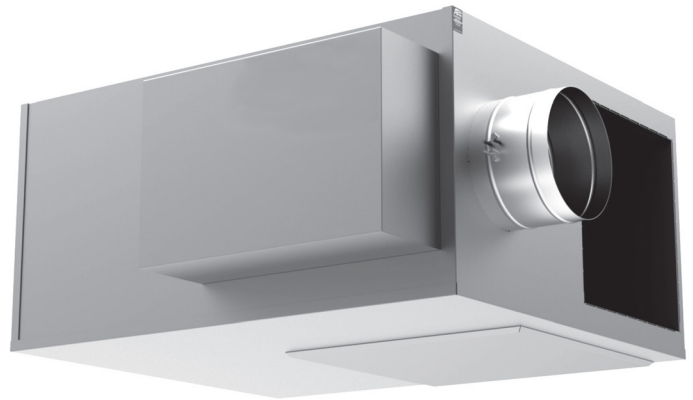

Fan Type	Series Fan Powered Terminal Units	Parallel Fan Powered Terminal Units
<b>Description</b>	In the series fan powered terminal, the primary air valve and fan are in the primary airstream, and are sized for the cooling load. The fan runs continuously during both heating and cooling modes. The volume of supply air remains constant at all times resulting in better diffuser performance and constant noise levels.	In the parallel fan powered terminal, the primary air valve is sized for the cooling airflow just as in single duct terminals. The fan section is outside of the primary airstream and typically runs only in the heating mode. It is typically sized for 50% of the maximum primary airflow which can result in lower noise levels, lower unit first costs, and reduced energy usage when compared to a series fan powered terminal due to the fan not being on at all times with fan being energized only during heating mode.
<b>Function</b>	Series Terminal Constant volume	Parallel Terminal Variable volume
<b>Fan Operation</b>	Continuous. Runs under heating and cooling in occupied and unoccupied modes.	Intermittent. Typically runs only under heating mode.
<b>Operation of Terminal</b>	Constant volume, variable temperature at all times. Supplemental heat raises supply temperature in stages.	Variable volume, constant temperature during cooling. Constant volume variable temperature during heating. Fan and supplemental heat raise supply temperature in stages.
<b>Terminal Fan Sizing</b>	For design airflow — heating or cooling, whichever is greater — at required downstream static pressure.	For design heating load at reduced downstream static pressure (typically 50% of cooling cfm).
<b>Central Fan Sizing</b>	Static pressure needed to overcome volume damper only.	Static pressure needed to overcome volume damper, heating coil, downstream duct, and diffusers.

Figure 7: Fan Powered Terminal Units Nomenclature

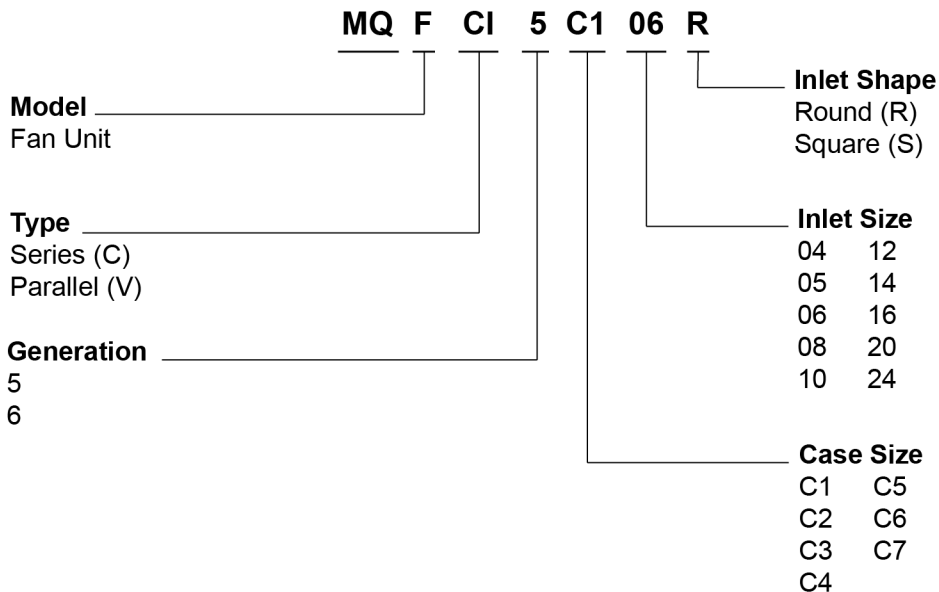

In a constant volume (or series) fan powered terminal, the fan runs continuously. Both primary and induced air are discharged through the fan.

**Figure 8: MQFCI-600 Series Fan Powered Unit**

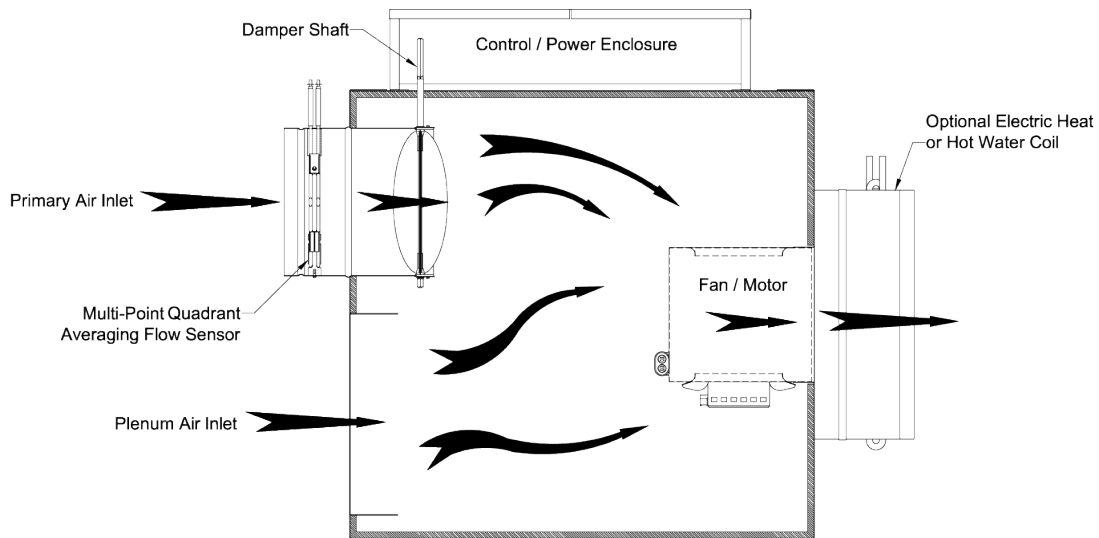

In a variable volume (or parallel) terminal unit, the fan runs only when heating is required. In cooling, the unit functions the same as a single duct VAV terminal.

**Figure 9: MQFVI-500 Parallel Fan Powered Unit**

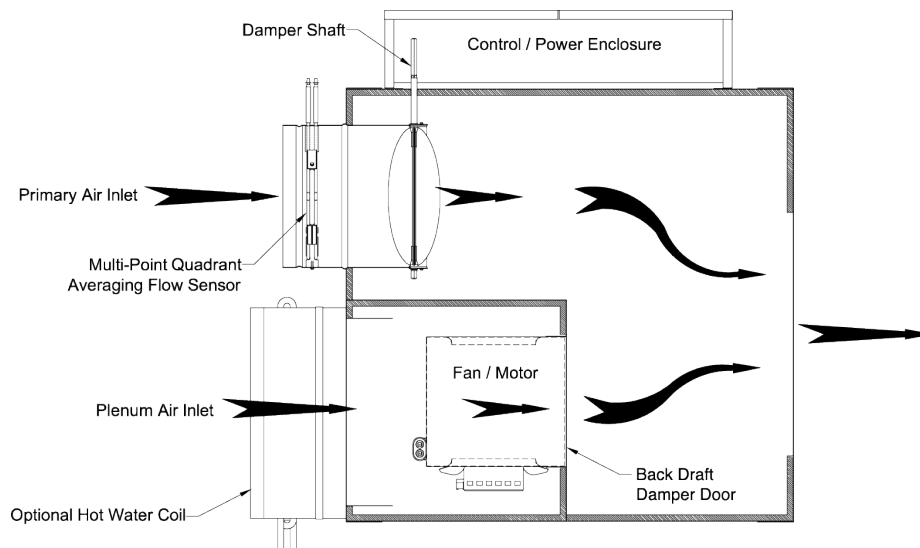

## Certification and Standards

- Units tested per ANSI/ASHRAE Standard 130.
- All model sizes certified in accordance with AHRI 880 certification program.
- ETL listed to meet requirements of UL 1995 and CSA 236.
- Dual-density fiberglass insulation meets UL 181 and NFPA 90A requirements.
- Insulation meets ASHRAE 62.1 requirements for resistance to mold growth and erosion.

## Options

- Inlet attenuator for quiet applications.
- SSR controlled electric heater.

## Series Fan Powered Terminal Units - MQFCI-600

Daikin Applied's series fan-powered terminal units are designed to provide superior comfort by supplying constant volume, variable temperature air into the occupied zone. Series fan-powered terminal units reduce central fan energy, allow for recovery of waste heat from the return plenum, lower operating costs, improve air circulation through better diffuser performance, and provide a constant sound level for maximum occupant comfort.

The primary function of the Daikin Applied series fan-powered terminal unit is to deliver a constant volume of conditioned air into the occupied zone. The terminal unit mixes conditioned air from the primary duct and warm air from the return plenum in varying amounts in response to a control signal. Supplemental heating is available in both electric heat and hot water coils if plenum heat is insufficient.

With the demands of today's building designs to reduce energy in smaller mechanical spaces, the Daikin Applied series fan-powered terminal unit is the perfect choice.

The Daikin Applied MQFCI series fan-powered terminal unit has been engineered to provide a balance between quiet operation, minimal footprint, and a broadflow range.

The MQFCI is constructed from 22 gauge metal designed to mitigate vibration and increase rigidity. The unique 4-piece case allows for fewer seams to minimize leakage. Every MQFCI includes bottom motor/blower access panel: These simple-to-remove panels provide access to allow trouble-free maintenance of the fan motor and blower assembly. The control enclosure for the MQFCI allows critical component access.

MQFCI units include 1" thick, matt-faced fiberglass insulation that complies with UL 181 horizontal burn test, NFPA 90A and UL 723/ASTM E 84 flame spread and smoke developed ratings of 25/50. Optional insulations include metal-foil-faced and fiber- and erosion-free ThermoPure (closed-cell foam), a polyolefin product with superior acoustical properties compared to solid metal duct liner.

### Standard Features

- MQFCI-600 is available in 6 casing sizes to handle 200–4400 cfm
- 22 ga. galvanized steel casing, mechanically sealed, low leakage construction
- Damper constructed of double layer, 18 ga. equivalent, galvanized steel with sandwiched flexible gasket, mechanically fastened to provide tight seal (<1% at 3.0 in.w.g. static pressure)
- Factory calibrated controls per each job requirement
- Multi-quadrant averaging flow sensor provides highly accurate +/- 5% flow readings after certified balancer has balanced terminal
- Easy access external balancing taps
- Standard highly efficient Electronically Commutated Motors (ECM)
- External control cabinet with offset mounting plate as standard
- Single-point electrical connections
- For added rigidity, the primary inlet incorporates 3 strengthening beads which also provide a stop for field attached flex duct, forms the seal where primary duct enters the casing and serves as the sealing surface for the damper assembly in closed position
- Round inlets available in sizes 6" through 16"
- 1" thick, dual density (1.5 lbs/ft<sup>3</sup> min.) fiberglass insulation with edges coated. Meets NFPA 90A and UL 181
- Flanged discharge with optional slip and drive cleat duct connection
- Removable bottom access panel provides complete access to motor/blower
- Independently tested and certified laboratory performance data
- Full range of options and accessories available (heating coils, disconnects, attenuators, etc.)
- Full range of liners/insulation available

## Components and Technology

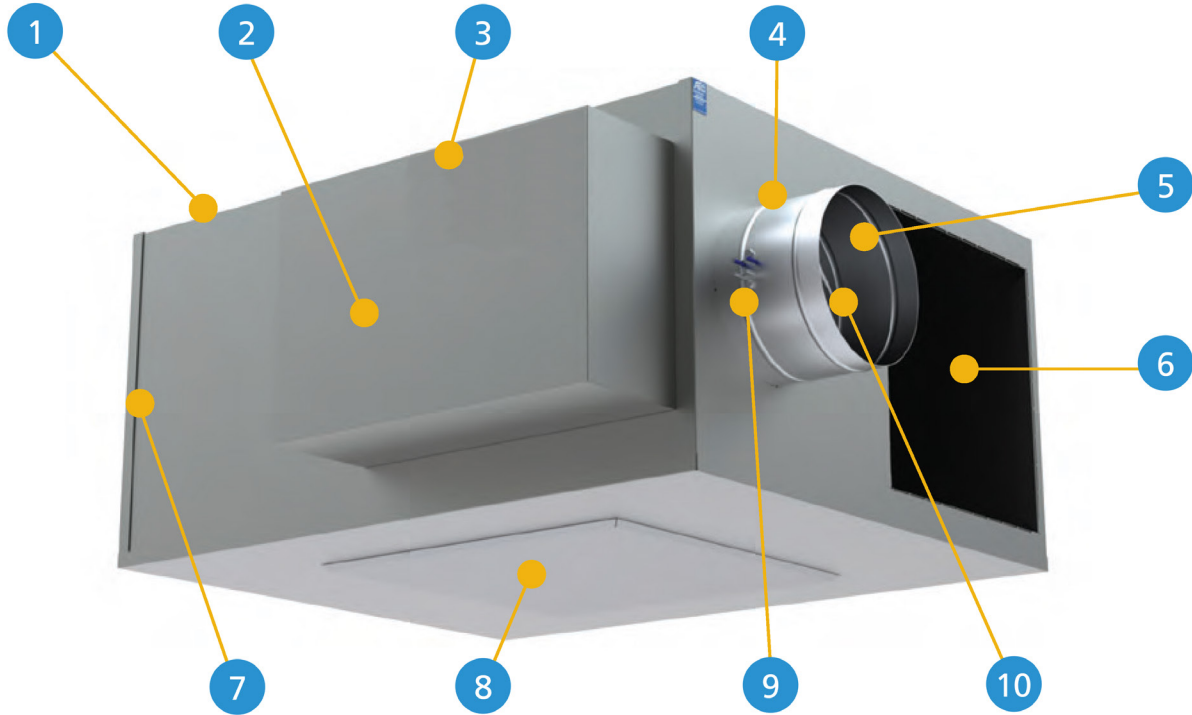

No.	Component	Description
1	Galvanized steel casing	Mechanically sealed for low leakage construction
2	NEMA 1 rated hinged control enclosure	With standoff to prevent penetration of casing
3	High efficiency ECM	Brushless-DC motor with built in speed and torque controls
4	Continuous butt-welded primary inlet duct	Minimizes leakage with 3 stiffening beads for added rigidity, provides a stop for field-attached flex duct, seals primary duct and casing; serves as damper assembly sealing surface in closed position
5	Double layer 18 gauge damper construction	With mechanically fastened integral blade seal
6	Field adjustable baffles	Top and bottom for balancing
7	18 gauge galvanized steel discharge panel	Manufactured to mitigate vibration
8	Bottom access panel	For easy motor/blower servicing
9	Multi-Quadrant averaging flow sensor	All metal construction inlet flow sensor with extra balancing taps
10	Durable damper assembly	Long life, low friction, self-lubricating thermoplastic bearing

# Dimensional Data

## MQFCI-600 Series Fan Powered Air Terminal Unit

Figure 10: MQFCI-600 ECM Series Fan Powered Air Terminal Unit Cooling Only

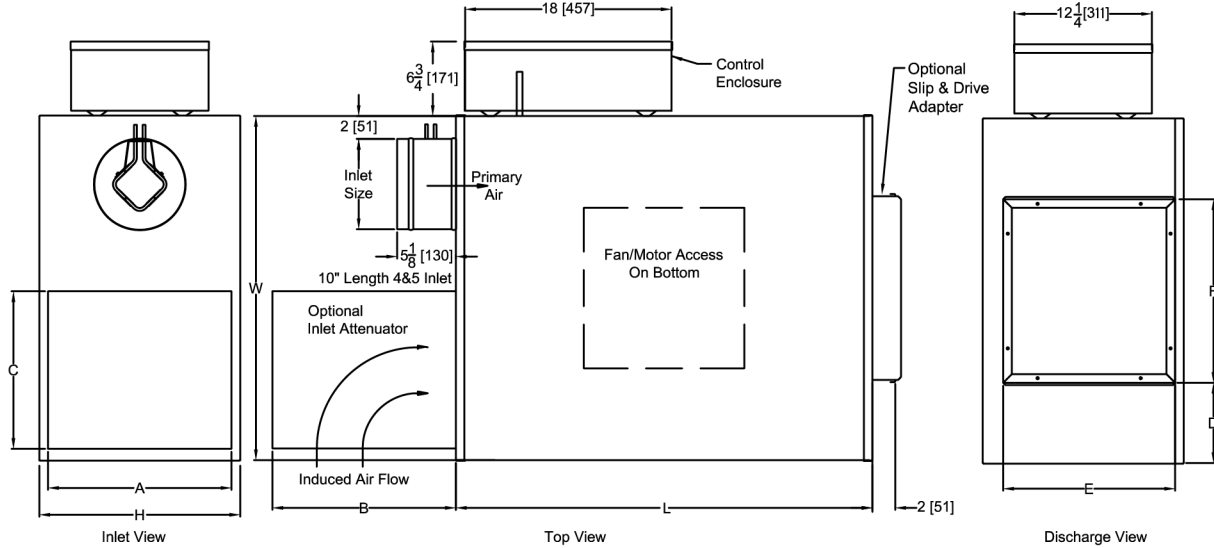

The standard location for control enclosure is Left Hand on Model MQFCI.  
Looking in the direction of airflow, the control enclosure is on the left.

Table 31: Unit Dimensions MQFCI-600 ECM Series Fan Powered Air Terminal Unit Cooling Only, in (mm)

Case Size	Inlet Size		Horsepower	Unit Dimensions			Induction Attenuator			Loc. D	Discharge	
	Standard	Optional		Height H	Width W	Length L	Height A	Width B	Length C		Height E	Width F
2	8 (203)	4, 5, 6, 10, 12	1/3	17-1/2 (445)	30 (718)	36 (914)	14 (356)	16 (406)	14 (356)	9-1/8 (231)	7-7/3 (197)	11-15/16 (303)
3	10 (254)	4, 5, 6, 8, 12, 14	1/3	17-1/2 (445)	36 (914)	40 (1016)	14 (356)	20 (508)	18 (457)	12-3/16 (309)	7-7/3 (197)	11-15/16 (303)
4	12 (305)	8, 10, 14	1/2	17-1/2 (445)	36 (914)	40 (1016)	14 (356)	20 (508)	18 (457)	12-3/4 (324)	10-7/8 (276)	10-5/8 (270)
5	14 (356)	10, 12, 14	1	20 (508)	40 (1016)	40 (1016)	16 (406)	20 (508)	18 (457)	13-1/2 (343)	11-3/16 (284)	13-1/4 (336)
6	16 (406)	10, 12, 14	1	20 (508)	42 (1067)	42 (1067)	16 (406)	24 (610)	20 (508)	14-1/8 (359)	13-1/2 (343)	14 (355)
7	18x16 (457x406)	12, 14, 16	1 (2)	20 (508)	46 (1168)	46 (1168)	16 (406)	24 (610)	22 (559)	5-13/16 (148)	9-1/2 (241)	13-1/4 (337)

NOTE 1: All filter sizes are equal to induction attenuator dimensions A & B.

NOTE 2: Field connected induction duct dimensions should equal A-2" & B-2" with a 1" flange.

Figure 11: MQFCI-600 ECM Series Fan Powered Air Terminal Unit with Hot Water Coil

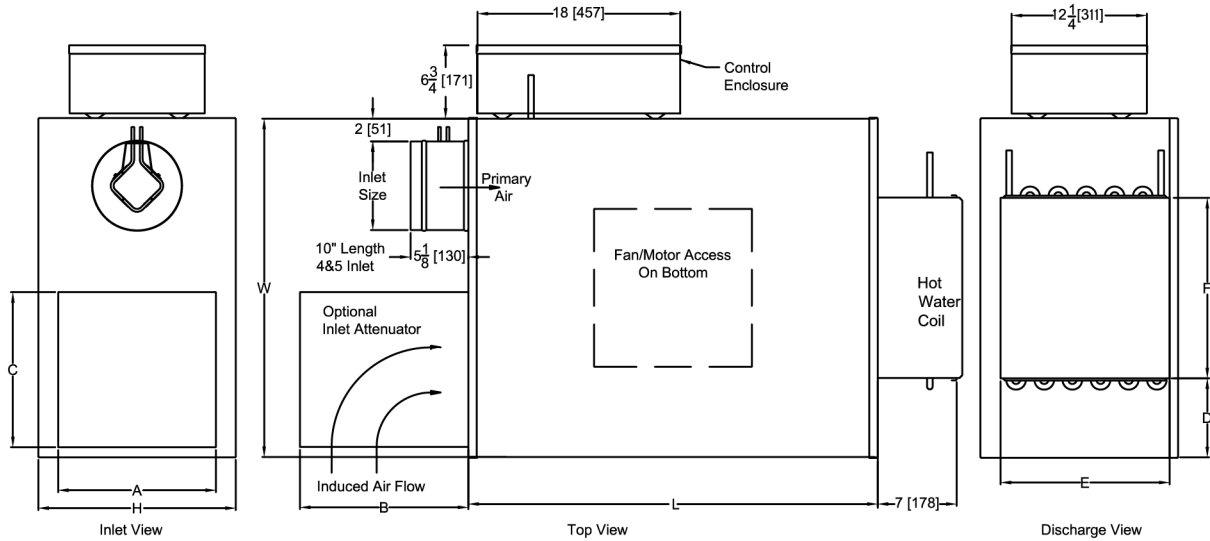

The standard location for control enclosure is Left Hand on Model MQFCI.  
Looking in the direction of airflow, the control enclosure is on the left.

Table 32: Unit Dimensions MQFCI-600 ECM Series Fan Powered Air Terminal Unit with Hot Water Coil, in (mm)

Case Size	Inlet Size		Horsepower	Unit Dimensions			Induction Attenuator			Loc. D	Discharge	
	Standard	Optional		Height H	Width W	Length L	Height A	Width B	Length C		Height E	Width F
2	8 (203)	4, 5, 6, 10, 12	1/3	17-1/2 (445)	30 (718)	36 (914)	14 (356)	16 (406)	14 (356)	7 (178)	15 (381)	16 (406)
3	10 (254)	4, 5, 6, 8, 12, 14	1/3	17-1/2 (445)	36 (914)	40 (1016)	14 (356)	20 (508)	18 (457)	8 (203)	17-1/2 (445)	20 (508)
4	12 (305)	8, 10, 14	1/2	17-1/2 (445)	36 (914)	40 (1016)	14 (356)	20 (508)	18 (457)	8 (203)	17-1/2 (445)	20 (508)
5	14 (356)	10, 12, 14	1	20 (508)	40 (1016)	40 (1016)	16 (406)	20 (508)	18 (457)	10 (254)	17-1/2 (445)	20 (508)
6	16 (406)	10, 12, 14	1	20 (508)	42 (1067)	42 (1067)	16 (406)	24 (610)	20 (508)	10 (254)	18 (457)	22 (559)
7	18×16 (457×406)	12, 14, 16	1 (2)	20 (508)	46 (1168)	46 (1168)	16 (406)	24 (610)	22 (559)	4 (102)	20 (508)	38 (965)

NOTE 1: All filter sizes are equal to induction attenuator dimensions A & B.

NOTE 2: Field connected induction duct dimensions should equal A-2" & B-2" with a 1" flange.

Figure 12: MQFCI-600 ECM Series Fan Powered Air Terminal Unit with Electric Heat

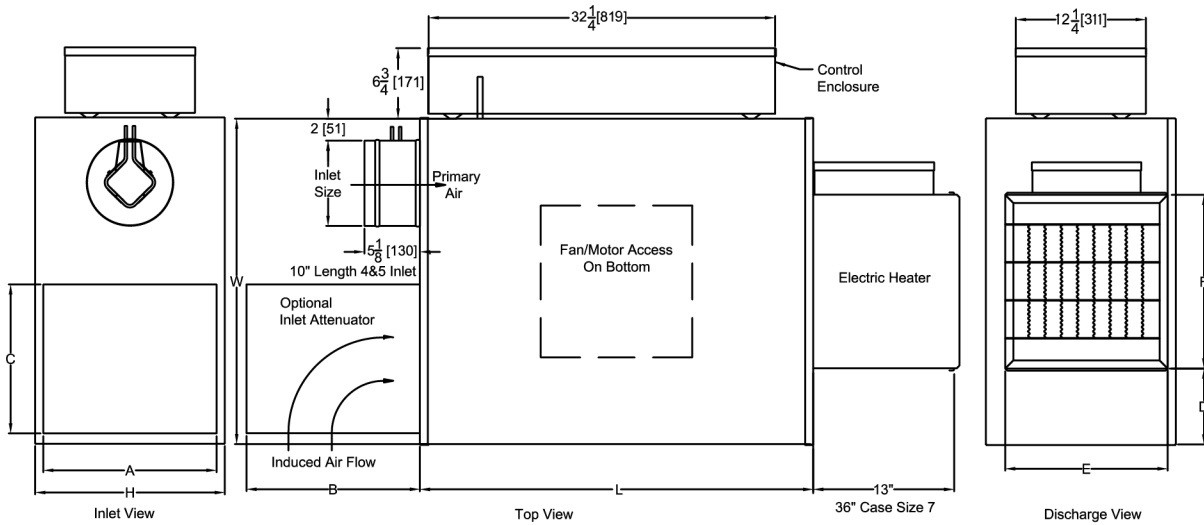

The standard location for control enclosure is Left Hand on Model MQFCI.  
Looking in the direction of airflow, the control enclosure is on the left.

Table 33: Unit Dimensions MQFCI-600 ECM Series Fan Powered Air Terminal Unit with Electric Heat, in (mm)

Case Size	Inlet Size		Horsepower	Unit Dimensions			Induction Attenuator			Loc. D	Discharge	
	Standard	Optional		Height H	Width W	Length L	Height A	Width B	Length C		Height E	Width F
2	8 (203)	4, 5, 6, 10, 12	1/3	17-1/2 (445)	30 (718)	36 (914)	14 (356)	16 (406)	14 (356)	7 (178)	15 (381)	16 (406)
3	10 (254)	4, 5, 6, 8, 12, 14	1/3	17-1/2 (445)	36 (914)	40 (1016)	14 (356)	20 (508)	18 (457)	8 (203)	17-1/2 (445)	20 (508)
4	12 (305)	8, 10, 14	1/2	17-1/2 (445)	36 (914)	40 (1016)	14 (356)	20 (508)	18 (457)	8 (203)	17-1/2 (445)	20 (508)
5	14 (356)	10, 12, 14	1	20 (508)	40 (1016)	40 (1016)	16 (406)	20 (508)	18 (457)	10 (254)	17-1/2 (445)	20 (508)
6	16 (406)	10, 12, 14	1	20 (508)	42 (1067)	42 (1067)	16 (406)	24 (610)	20 (508)	10 (254)	18 (457)	22 (559)
7	18x16 (457x406)	12, 14, 16	1 (2)	20 (508)	46 (1168)	46 (1168)	16 (406)	24 (610)	22 (559)	4 (102)	20 (508)	38 (965)

NOTE 1: All filter sizes are equal to induction attenuator dimensions A & B.

NOTE 2: Field connected induction duct dimensions should equal A-2" & B-2" with a 1" flange.

Table 34: FCI-600 Approximate Shipping Weights

Case	FCI (lbs)
2	124
3	165
4	165
5	198
6	220
7	260

NOTE: The weight is considering all the options that can be added to a box, including the weight of the boxes with different hot water or electric heat options. In the case of the hot water coil, water weight is not included.

Table 35: FCI-600 Filter Sizes per Case Size

Case Size	Filter Dimension (in)
2	16 x 16
3	20 x 16
4	20 x 16
5	20 x 20
6	24 x 20
7	20 x 20

NOTE: Filters are mounted on the fan induction and are available in 1" or 2" thicknesses.



# Performance Data

## MQFCI-600 AHRI Certified Rating Points

### Certifications and Standards

- Units tested per ANSI/ASHRAE Standard 130
- All model sizes certified in accordance with AHRI 880 certification program
- ETL listed to meet requirements of UL 1995 and CSA 236
- Dual-density fiberglass insulation meets UL 181 and NFPA 90A requirements
- Insulation meets ASHRAE 62.1 requirements for resistance to mold growth and erosion



**Table 36: MQFCI-600 AHRI Certified Radiated Sound Power, Fan Only**

Case Size	Inlet Size (in)	Fan CFM	Octave Band						Electrical Power (Watts)
			2	3	4	5	6	7	
2	8	400	57	51	50	33	33	29	155
3	10	700	58	55	46	39	37	37	230
4	12	1200	65	64	50	47	45	42	430
5	14	1800	67	67	56	51	50	48	770
6	16	2400	67	67	56	51	50	48	1350
7	18×16	2700	74	66	60	54	54	53	1700

**Table 37: MQFCI-600 AHRI Certified Radiated Sound Power, Inlet Ps = 1.5 in.w.g. Static Pressure**

Case Size	Inlet Size (in)	Fan CFM	Primary CFM	Min Ps	Octave Band					
					2	3	4	5	6	7
2	8	400	400	0.03	57	56	52	42	44	44
3	10	700	700	0.03	62	59	52	45	45	46
4	12	1200	1200	0.01	67	65	52	50	50	46
5	14	1800	1800	0.02	72	71	61	56	54	51
6	16	2400	2400	0.01	73	71	65	58	56	54
7	18×16	2700	2700	0.09	77	72	66	57	56	55

**Table 38: MQFCI-600 AHRI Certified Discharge Sound Power, Fan Only**

Case Size	Inlet Size (in)	Fan CFM	Octave Band						Electrical Power (Watts)
			2	3	4	5	6	7	
2	8	400	54	57	58	50	49	45	155
3	10	700	58	60	61	59	56	54	230
4	12	1200	62	68	65	64	64	63	430
5	14	1800	69	68	72	70	67	66	770
6	16	2400	73	73	75	74	74	74	1350
7	18×16	2700	79	71	70	69	68	67	1700

**Table 39: MQFCI-600 ECM Radiated Sound Power Level at Fan Only, Inlet Ps = 0.50 and 0.75 in.w.g.**

Case Size	Inlet Size (in)	CFM (L/s)	Min Ps in.w.g. (Pa)	Fan Only							Inlet Ps = 0.50 in.w.g. (125 Pa)							Inlet Ps = 0.75 in.w.g. (187 Pa)										
				Octave Band Sound Power, Lw, dB							NC	NC w/ SA	Octave Band Sound Power, Lw, dB							NC	NC w/ SA	Octave Band Sound Power, Lw, dB						
				2	3	4	5	6	7	2			3	4	5	6	7	2	3			4	5	6	7			
2	8	200 (94)	0.007 (1.6)	53	49	47	28	27	22	<b>21</b>	<b>&lt;15</b>	53	50	48	31	30	26	<b>22</b>	<b>15</b>	53	51	48	35	33	30	<b>22</b>	<b>15</b>	
		300 (142)	0.017 (4.2)	55	50	49	31	30	26	<b>23</b>	<b>17</b>	55	52	49	33	33	29	<b>23</b>	<b>17</b>	55	53	50	37	36	33	<b>24</b>	<b>18</b>	
		400 (189)	0.031 (7.7)	57	51	50	33	33	29	<b>24</b>	<b>18</b>	57	52	51	35	36	33	<b>25</b>	<b>19</b>	57	54	51	38	39	37	<b>25</b>	<b>19</b>	
		500 (236)	0.045 (11.2)	58	52	51	34	34	30	<b>25</b>	<b>19</b>	58	53	51	36	37	34	<b>25</b>	<b>19</b>	58	55	52	38	39	38	<b>26</b>	<b>20</b>	
		600 (283)	0.076 (18.9)	60	53	52	35	35	31	<b>26</b>	<b>21</b>	60	54	52	37	37	35	<b>26</b>	<b>21</b>	60	56	53	39	40	39	<b>27</b>	<b>21</b>	
		750 (354)	0.110 (27.4)	62	55	53	36	36	33	<b>27</b>	<b>23</b>	62	56	54	38	39	37	<b>29</b>	<b>23</b>	62	58	54	41	42	41	<b>29</b>	<b>23</b>	
3	10	300 (142)	0.006 (1.4)	56	52	43	35	32	32	<b>20</b>	<b>16</b>	56	53	44	38	36	35	<b>21</b>	<b>16</b>	57	53	45	40	38	37	<b>21</b>	<b>17</b>	
		400 (189)	0.010 (2.6)	56	53	43	36	34	33	<b>21</b>	<b>16</b>	57	54	45	39	37	36	<b>22</b>	<b>18</b>	58	54	46	41	39	38	<b>22</b>	<b>18</b>	
		500 (236)	0.016 (4.0)	57	53	44	37	35	34	<b>21</b>	<b>17</b>	58	55	46	40	37	37	<b>24</b>	<b>19</b>	58	55	47	42	40	39	<b>24</b>	<b>19</b>	
		600 (283)	0.023 (5.8)	57	54	45	38	36	36	<b>22</b>	<b>18</b>	58	55	47	41	38	38	<b>24</b>	<b>19</b>	59	56	48	43	41	40	<b>25</b>	<b>20</b>	
		700 (330)	0.032 (7.9)	58	55	46	39	37	37	<b>24</b>	<b>19</b>	59	56	47	41	39	39	<b>25</b>	<b>20</b>	60	57	48	44	42	41	<b>26</b>	<b>21</b>	
		800 (378)	0.041 (10.3)	60	57	46	41	40	40	<b>26</b>	<b>21</b>	60	58	48	43	41	42	<b>27</b>	<b>22</b>	62	59	49	46	44	44	<b>28</b>	<b>24</b>	
		900 (425)	0.052 (13.0)	61	58	47	43	42	42	<b>27</b>	<b>22</b>	62	59	49	45	43	44	<b>28</b>	<b>24</b>	63	61	50	47	45	46	<b>31</b>	<b>26</b>	
4	12	400 (189)	0.001 (0.2)	56	54	45	39	36	31	<b>22</b>	<b>18</b>	58	56	46	41	38	33	<b>25</b>	<b>20</b>	60	58	47	43	39	35	<b>27</b>	<b>22</b>	
		600 (283)	0.002 (0.4)	57	55	45	39	36	31	<b>24</b>	<b>19</b>	59	57	46	41	38	33	<b>26</b>	<b>21</b>	61	59	47	43	39	35	<b>28</b>	<b>24</b>	
		800 (378)	0.002 (0.4)	58	56	46	40	38	33	<b>25</b>	<b>20</b>	60	58	47	42	40	35	<b>27</b>	<b>22</b>	62	60	48	44	41	37	<b>29</b>	<b>25</b>	
		1000 (472)	0.004 (0.9)	61	60	48	44	42	38	<b>29</b>	<b>25</b>	61	60	49	46	44	40	<b>29</b>	<b>25</b>	63	62	50	47	45	42	<b>32</b>	<b>27</b>	
		1200 (566)	0.010 (2.5)	65	64	50	47	45	42	<b>34</b>	<b>29</b>	65	64	51	49	47	44	<b>34</b>	<b>29</b>	66	64	52	50	48	46	<b>34</b>	<b>29</b>	
		1400 (661)	0.016 (4.1)	65	65	53	50	49	46	<b>35</b>	<b>31</b>	65	65	53	52	51	48	<b>35</b>	<b>31</b>	66	66	53	52	52	50	<b>37</b>	<b>32</b>	
		1600 (755)	0.026 (6.6)	66	66	57	52	52	48	<b>37</b>	<b>32</b>	67	67	57	54	54	50	<b>38</b>	<b>33</b>	69	69	57	54	55	52	<b>40</b>	<b>35</b>	
5	14	1000 (472)	0.006 (1.5)	63	60	50	43	42	37	<b>29</b>	<b>25</b>	65	61	51	45	42	38	<b>31</b>	<b>27</b>	66	62	52	47	44	39	<b>32</b>	<b>29</b>	
		1200 (566)	0.009 (2.2)	65	61	52	45	44	40	<b>31</b>	<b>27</b>	67	63	52	47	44	40	<b>33</b>	<b>30</b>	68	64	53	48	46	42	<b>34</b>	<b>31</b>	
		1400 (661)	0.012 (3.0)	66	64	53	48	47	43	<b>34</b>	<b>29</b>	68	65	54	49	47	44	<b>35</b>	<b>31</b>	70	66	55	50	49	45	<b>37</b>	<b>34</b>	
		1600 (755)	0.016 (3.9)	67	66	54	50	50	47	<b>37</b>	<b>32</b>	69	68	55	51	50	47	<b>39</b>	<b>34</b>	71	68	56	52	51	47	<b>39</b>	<b>35</b>	
		1800 (849)	0.020 (5.0)	67	67	56	51	50	48	<b>38</b>	<b>33</b>	69	70	57	53	52	50	<b>41</b>	<b>37</b>	71	71	58	54	53	50	<b>42</b>	<b>38</b>	
		2000 (944)	0.025 (6.1)	69	70	57	54	54	52	<b>41</b>	<b>37</b>	70	72	59	55	54	52	<b>44</b>	<b>39</b>	72	73	60	56	55	52	<b>45</b>	<b>40</b>	
6	16	1600 (755)	0.003 (0.7)	60	60	53	45	42	41	<b>29</b>	<b>25</b>	63	62	56	48	45	43	<b>32</b>	<b>27</b>	64	63	58	49	46	44	<b>33</b>	<b>28</b>	
		1800 (849)	0.005 (1.2)	62	62	53	48	44	43	<b>32</b>	<b>27</b>	65	64	57	50	46	45	<b>34</b>	<b>29</b>	66	65	58	51	47	46	<b>35</b>	<b>31</b>	
		2000 (944)	0.007 (1.7)	64	64	54	49	46	44	<b>34</b>	<b>29</b>	66	66	57	51	48	46	<b>37</b>	<b>32</b>	67	66	59	52	49	47	<b>37</b>	<b>32</b>	
		2200 (1038)	0.008 (2.0)	65	65	55	49	48	46	<b>35</b>	<b>31</b>	68	67	58	52	50	48	<b>38</b>	<b>33</b>	69	68	60	53	51	49	<b>39</b>	<b>34</b>	
		2400 (1133)	0.010 (2.5)	67	67	56	51	50	48	<b>38</b>	<b>33</b>	69	69	59	54	52	50	<b>40</b>	<b>35</b>	70	69	61	55	53	51	<b>40</b>	<b>35</b>	
		2600 (1227)	0.011 (2.7)	69	69	57	55	53	51	<b>40</b>	<b>35</b>	71	70	60	56	55	53	<b>41</b>	<b>37</b>	72	71	62	57	55	53	<b>42</b>	<b>38</b>	
		2800 (1321)	0.012 (3.0)	72	72	58	59	56	54	<b>44</b>	<b>39</b>	74	73	62	59	57	55	<b>45</b>	<b>40</b>	74	73	63	59	57	55	<b>45</b>	<b>40</b>	
7	18x16	2200 (1038)	0.068 (17.0)	69	62	57	52	52	51	<b>34</b>	<b>32</b>	70	63	58	53	52	52	<b>35</b>	<b>34</b>	72	64	59	53	53	53	<b>38</b>	<b>36</b>	
		2500 (1180)	0.082 (20.5)	71	64	59	54	54	52	<b>36</b>	<b>35</b>	72	65	60	55	54	53	<b>38</b>	<b>36</b>	74	66	61	55	55	54	<b>40</b>	<b>39</b>	
		2700 (1274)	0.091 (22.8)	74	66	60	54	54	53	<b>40</b>	<b>39</b>	75	68	62	55	55	54	<b>41</b>	<b>40</b>	76	69	63	56	55	54	<b>43</b>	<b>41</b>	
		3000 (1416)	0.105 (26.1)	75	67	61	55	55	54	<b>41</b>	<b>40</b>	76	69	63	56	56	55	<b>43</b>	<b>41</b>	77	70	64	57	56	55	<b>44</b>	<b>43</b>	
		4000 (1888)	0.151 (37.6)	78	71	65	59	60	57	<b>45</b>	<b>44</b>	79	72	66	59	60	57	<b>46</b>	<b>45</b>	79	73	67	60	60	58	<b>46</b>	<b>45</b>	
		4400 (2076)	0.163 (40.5)	79	72	66	61	62	59	<b>46</b>	<b>45</b>	80	73	67	62	63	60	<b>48</b>	<b>46</b>	80	74	68	63	64	62	<b>48</b>	<b>46</b>	

**NOTE 1:** Performance data contained within a bold border outline are AHRI certified data.

**NOTE 2:** Performance data not contained within a bold border outline are application ratings. Application ratings are outside the scope of the Certification Program.

**NOTE 3:** Performance data is obtained from laboratory testing in accordance with AHRI 880-2011 and ANSI/ASHRAE 130-2008.

**NOTE 4:** NC values are calculated using attenuation credits outlined in Appendix E of AHRI 885-2008.

**NOTE 5:** Air terminal units were tested with an external static pressure of 0.25 in.w.g.

**NOTE 6:** Discharge Sound power levels shown with End Reflection Corrections Included in dB (ref: 10<sup>-12</sup> watts).

**NOTE 7:** Minimum Ps is the static pressure drop across the air terminal unit while the inlet damper is in the wide-open position at a given airflow rate and the fan is on.

**Table 40: MQFCI-600 ECM Radiated Sound Power Level at Inlet Ps = 1.0, 1.5, and 2.0 in.w.g.**

Case Size	Inlet Size (in)	CFM (L/s)	Min Ps in.w.g. (Pa)	Fan Only							Inlet Ps = 0.50 in.w.g. (125 Pa)							Inlet Ps = 0.75 in.w.g. (187 Pa)												
				Octave Band Sound Power, Lw, dB							NC	NC w/ SA	Octave Band Sound Power, Lw, dB							NC	NC w/ SA	Octave Band Sound Power, Lw, dB							NC	NC w/ SA
				2	3	4	5	6	7	2			3	4	5	6	7	2	3			4	5	6	7					
2	8	200 (94)	0.007 (1.6)	53	52	49	35	35	34	<b>23</b>	<b>17</b>	53	54	49	38	38	37	<b>23</b>	<b>18</b>	55	56	50	42	40	39	<b>25</b>	<b>20</b>			
		300 (142)	0.017 (4.2)	55	54	50	38	38	37	<b>24</b>	<b>18</b>	55	55	51	40	41	41	<b>25</b>	<b>19</b>	57	57	52	43	43	43	<b>26</b>	<b>21</b>			
		400 (189)	0.031 (7.7)	57	55	52	40	41	40	<b>26</b>	<b>20</b>	57	56	52	42	44	44	<b>26</b>	<b>20</b>	59	58	53	44	46	46	<b>27</b>	<b>22</b>			
		500 (236)	0.045 (11.2)	58	56	52	41	42	41	<b>26</b>	<b>20</b>	58	57	53	43	45	45	<b>27</b>	<b>21</b>	60	59	54	45	47	47	<b>29</b>	<b>24</b>			
		600 (283)	0.076 (18.9)	60	57	53	41	43	42	<b>27</b>	<b>21</b>	60	58	54	44	46	46	<b>29</b>	<b>22</b>	62	60	55	46	48	48	<b>30</b>	<b>25</b>			
		750 (354)	0.110 (27.4)	62	59	55	43	44	44	<b>30</b>	<b>24</b>	62	60	55	45	47	48	<b>30</b>	<b>25</b>	64	62	56	47	49	50	<b>32</b>	<b>27</b>			
3	10	300 (142)	0.006 (1.4)	57	53	47	41	40	38	<b>21</b>	<b>17</b>	57	53	49	42	42	43	<b>23</b>	<b>17</b>	57	53	51	44	45	46	<b>25</b>	<b>19</b>			
		400 (189)	0.010 (2.6)	58	54	47	42	41	39	<b>22</b>	<b>18</b>	58	54	50	43	43	43	<b>24</b>	<b>18</b>	58	55	51	45	46	47	<b>25</b>	<b>19</b>			
		500 (236)	0.016 (4.0)	59	55	48	43	42	41	<b>24</b>	<b>20</b>	60	56	50	43	43	44	<b>25</b>	<b>21</b>	60	56	52	46	46	48	<b>26</b>	<b>21</b>			
		600 (283)	0.023 (5.8)	60	56	48	44	43	42	<b>25</b>	<b>21</b>	61	57	51	44	44	45	<b>26</b>	<b>22</b>	61	58	53	47	47	48	<b>27</b>	<b>22</b>			
		700 (330)	0.032 (7.9)	61	57	49	45	44	43	<b>26</b>	<b>22</b>	62	59	52	45	45	46	<b>28</b>	<b>24</b>	63	60	54	47	48	49	<b>29</b>	<b>25</b>			
		800 (378)	0.041 (10.3)	62	60	50	47	45	45	<b>29</b>	<b>25</b>	64	61	53	47	46	47	<b>31</b>	<b>26</b>	64	62	55	48	48	50	<b>32</b>	<b>27</b>			
		900 (425)	0.052 (13.0)	64	61	51	49	47	47	<b>31</b>	<b>26</b>	65	62	54	49	48	49	<b>32</b>	<b>27</b>	66	63	56	49	50	51	<b>33</b>	<b>29</b>			
4	12	400 (189)	0.001 (0.3)	62	59	49	43	40	35	<b>28</b>	<b>24</b>	63	60	50	46	41	35	<b>29</b>	<b>25</b>	64	61	53	48	43	39	<b>31</b>	<b>26</b>			
		600 (283)	0.002 (0.6)	63	60	49	43	40	35	<b>29</b>	<b>25</b>	64	61	50	46	41	35	<b>31</b>	<b>26</b>	65	62	53	48	43	39	<b>32</b>	<b>27</b>			
		800 (378)	0.002 (1.2)	64	61	50	44	42	37	<b>31</b>	<b>26</b>	65	62	51	47	43	37	<b>32</b>	<b>27</b>	66	63	54	49	45	41	<b>33</b>	<b>29</b>			
		1000 (472)	0.004 (2.0)	65	63	51	47	46	42	<b>33</b>	<b>28</b>	66	64	52	49	47	42	<b>34</b>	<b>29</b>	67	65	54	51	49	46	<b>35</b>	<b>31</b>			
		1200 (566)	0.010 (3.5)	66	64	52	50	49	46	<b>34</b>	<b>29</b>	67	65	52	50	50	46	<b>35</b>	<b>31</b>	68	66	55	52	52	50	<b>37</b>	<b>32</b>			
		1400 (661)	0.016 (5.7)	68	67	53	52	53	50	<b>38</b>	<b>33</b>	69	68	54	52	54	50	<b>39</b>	<b>34</b>	70	69	57	54	56	54	<b>40</b>	<b>35</b>			
		1600 (755)	0.026 (9.2)	71	70	58	54	56	52	<b>41</b>	<b>37</b>	72	71	58	54	57	52	<b>42</b>	<b>38</b>	73	72	59	55	59	56	<b>44</b>	<b>39</b>			
5	14	1000 (472)	0.006 (7.2)	67	62	54	48	45	40	<b>32</b>	<b>30</b>	67	62	55	49	45	40	<b>32</b>	<b>30</b>	67	62	56	50	45	40	<b>32</b>	<b>30</b>			
		1200 (566)	0.009 (10.3)	69	64	55	49	47	43	<b>34</b>	<b>32</b>	69	64	56	50	47	43	<b>34</b>	<b>32</b>	69	64	57	51	47	43	<b>34</b>	<b>32</b>			
		1400 (661)	0.012 (14.0)	71	66	57	51	50	46	<b>37</b>	<b>35</b>	71	66	58	52	50	46	<b>37</b>	<b>35</b>	71	66	59	53	50	46	<b>37</b>	<b>35</b>			
		1600 (755)	0.016 (18.3)	72	68	58	53	52	48	<b>39</b>	<b>36</b>	72	68	59	54	52	48	<b>39</b>	<b>36</b>	72	68	60	55	52	48	<b>39</b>	<b>36</b>			
		1800 (849)	0.020 (23.2)	72	71	60	55	54	51	<b>42</b>	<b>38</b>	72	71	61	56	54	51	<b>42</b>	<b>38</b>	72	71	62	57	54	51	<b>42</b>	<b>38</b>			
		2000 (944)	0.025 (28.6)	73	73	62	57	56	53	<b>45</b>	<b>40</b>	73	73	63	58	56	53	<b>45</b>	<b>40</b>	73	73	64	59	56	53	<b>45</b>	<b>40</b>			
6	16	1600 (755)	0.003 (7.5)	66	64	60	51	47	46	<b>35</b>	<b>29</b>	68	65	62	53	49	47	<b>37</b>	<b>31</b>	69	66	62	53	50	48	<b>37</b>	<b>32</b>			
		1800 (849)	0.005 (9.7)	67	66	61	52	49	48	<b>37</b>	<b>32</b>	69	67	63	53	50	49	<b>38</b>	<b>33</b>	70	68	64	54	51	50	<b>39</b>	<b>34</b>			
		2000 (944)	0.007 (11.9)	69	67	61	53	51	49	<b>38</b>	<b>33</b>	70	68	63	54	52	50	<b>39</b>	<b>34</b>	71	69	64	55	53	51	<b>40</b>	<b>35</b>			
		2200 (1038)	0.008 (14.4)	70	69	62	54	53	51	<b>40</b>	<b>35</b>	72	70	64	56	54	52	<b>41</b>	<b>37</b>	73	71	65	57	54	53	<b>42</b>	<b>38</b>			
		2400 (1133)	0.010 (17.2)	72	70	63	56	55	53	<b>41</b>	<b>37</b>	73	71	65	58	56	54	<b>42</b>	<b>38</b>	74	71	66	59	57	55	<b>42</b>	<b>39</b>			
		2600 (1227)	0.011 (20.2)	74	71	64	57	56	54	<b>42</b>	<b>39</b>	75	72	66	58	57	55	<b>44</b>	<b>40</b>	76	72	66	59	57	56	<b>44</b>	<b>41</b>			
7	18x16	2200 (1038)	0.068 (17.0)	73	65	60	54	53	54	<b>39</b>	<b>38</b>	74	67	61	54	53	54	<b>40</b>	<b>39</b>	76	69	65	55	54	54	<b>42</b>	<b>41</b>			
		2500 (1180)	0.082 (20.5)	75	67	62	56	55	55	<b>41</b>	<b>40</b>	76	69	63	56	55	55	<b>43</b>	<b>41</b>	78	71	67	57	56	55	<b>45</b>	<b>44</b>			
		2700 (1274)	0.091 (22.8)	77	71	65	57	56	55	<b>44</b>	<b>43</b>	77	72	66	57	56	55	<b>44</b>	<b>43</b>	79	72	68	58	57	56	<b>46</b>	<b>45</b>			
		3000 (1416)	0.105 (26.1)	78	72	66	58	57	56	<b>45</b>	<b>44</b>	78	73	67	58	57	56	<b>45</b>	<b>44</b>	81	74	70	60	59	58	<b>49</b>	<b>48</b>			
		4000 (1888)	0.151 (37.6)	80	74	68	60	60	58	<b>48</b>	<b>46</b>	80	75	69	60	61	58	<b>48</b>	<b>46</b>	85	78	74	64	63	62	<b>54</b>	<b>53</b>			
		4400 (2076)	0.163 (40.5)	81	75	69	64	65	63	<b>49</b>	<b>48</b>	81	76	70	65	65	64	<b>49</b>	<b>48</b>	86	79	76	67	66	66	<b>55</b>	<b>54</b>			

- NOTE 1:** Performance data contained within a bold border outline are AHRI certified data.
- NOTE 2:** Performance data not contained within a bold border outline are application ratings. Application ratings are outside the scope of the Certification Program.
- NOTE 3:** Performance data is obtained from laboratory testing in accordance with AHRI 880-2011 and ANSI/ASHRAE 130-2008.
- NOTE 4:** NC values are calculated using attenuation credits outlined in Appendix E of AHRI 885-2008.
- NOTE 5:** Air terminal units were tested with an external static pressure of 0.25 in.w.g.
- NOTE 6:** Discharge Sound power levels shown with End Reflection Corrections Included in dB (ref: 10<sup>-12</sup> watts).
- NOTE 7:** Minimum Ps is the static pressure drop across the air terminal unit while the inlet damper is in the wide-open position at a given airflow rate and the fan is on.

**Table 41: MQFCI-600 ECM Radiated Sound Power Level at Fan Only, Inlet Ps = 0.50 and 0.75 in.w.g.**

Case Size	Inlet Size (in)	CFM (L/s)	Min Ps in.w.g. (Pa)	Fan Only							Inlet Ps = 0.50 in.w.g. (125 Pa)							Inlet Ps = 0.75 in.w.g. (187 Pa)									
				Octave Band Sound Power, Lw, dB							NC	Octave Band Sound Power, Lw, dB							NC	Octave Band Sound Power, Lw, dB							NC
				2	3	4	5	6	7	2		3	4	5	6	7	2	3		4	5	6	7				
2	8	200 (94)	0.007 (1.6)	55	58	56	47	44	39	<b>16</b>	56	59	57	48	45	40	<b>18</b>	56	59	57	49	45	40	<b>18</b>			
		300 (142)	0.017 (4.2)	57	59	58	49	47	43	<b>16</b>	58	60	59	50	48	44	<b>18</b>	58	60	59	51	48	44	<b>18</b>			
		400 (189)	0.031 (7.7)	59	60	59	51	50	46	<b>18</b>	60	61	60	52	51	47	<b>19</b>	60	61	60	52	51	47	<b>19</b>			
		500 (236)	0.045 (11.2)	60	61	60	52	51	47	<b>19</b>	61	62	61	53	52	48	<b>20</b>	61	62	61	53	52	48	<b>20</b>			
		600 (283)	0.076 (18.9)	62	62	61	53	52	48	<b>20</b>	63	63	62	54	53	49	<b>21</b>	63	63	62	54	53	49	<b>21</b>			
		750 (354)	0.110 (27.4)	64	64	62	54	53	50	<b>21</b>	65	65	63	55	54	51	<b>22</b>	65	65	63	55	54	51	<b>22</b>			
3	10	300 (142)	0.006 (1.4)	60	58	62	55	51	49	<b>15</b>	61	59	63	56	52	50	<b>17</b>	61	59	63	56	52	50	<b>17</b>			
		400 (189)	0.010 (2.6)	61	60	62	57	54	51	<b>18</b>	62	61	63	58	55	52	<b>19</b>	62	61	63	58	55	52	<b>19</b>			
		500 (236)	0.016 (4.0)	62	60	62	58	55	52	<b>18</b>	63	61	63	59	56	53	<b>19</b>	63	61	63	59	56	53	<b>19</b>			
		600 (283)	0.023 (5.8)	62	61	62	59	56	54	<b>19</b>	63	62	63	60	57	55	<b>20</b>	63	62	63	60	57	55	<b>20</b>			
		700 (330)	0.032 (7.9)	63	62	62	60	57	55	<b>20</b>	64	63	63	61	58	56	<b>21</b>	64	63	63	61	58	56	<b>21</b>			
		800 (378)	0.041 (10.3)	65	64	62	62	60	58	<b>22</b>	66	65	63	63	61	59	<b>23</b>	66	65	63	63	61	59	<b>23</b>			
		900 (425)	0.052 (13.0)	66	65	63	64	62	60	<b>24</b>	67	66	64	65	63	61	<b>25</b>	67	66	64	65	63	61	<b>25</b>			
4	12	400 (189)	0.004 (0.3)	62	60	55	54	53	49	<b>18</b>	63	61	56	55	54	50	<b>19</b>	63	62	56	55	54	50	<b>20</b>			
		600 (283)	0.010 (0.6)	64	62	59	57	56	53	<b>20</b>	65	63	60	58	57	54	<b>21</b>	65	64	60	58	57	54	<b>22</b>			
		800 (378)	0.018 (1.2)	65	66	60	58	58	55	<b>24</b>	66	67	61	59	59	56	<b>25</b>	66	68	61	59	59	56	<b>26</b>			
		1000 (472)	0.028 (2.0)	66	69	62	62	60	57	<b>27</b>	67	70	63	63	63	61	<b>28</b>	67	71	63	63	63	61	<b>29</b>			
		1200 (566)	0.040 (3.5)	67	72	66	65	65	64	<b>31</b>	68	73	67	66	66	65	<b>32</b>	68	74	67	66	66	65	<b>33</b>			
		1400 (661)	0.054 (5.7)	69	73	67	68	69	68	<b>32</b>	70	74	68	69	70	69	<b>33</b>	70	75	68	69	70	69	<b>34</b>			
		1600 (755)	0.071 (9.2)	72	74	71	70	72	70	<b>33</b>	73	75	72	71	73	71	<b>34</b>	73	76	72	71	73	71	<b>35</b>			
		1000 (472)	0.015 (7.2)	70	62	65	62	60	55	<b>21</b>	71	63	66	63	61	56	<b>22</b>	71	63	66	63	61	56	<b>22</b>			
5	14	1200 (566)	0.022 (10.3)	72	64	69	65	62	59	<b>23</b>	73	65	70	66	63	60	<b>25</b>	73	65	70	66	63	60	<b>25</b>			
		1400 (661)	0.030 (14.0)	73	67	70	68	65	62	<b>26</b>	74	68	71	69	66	63	<b>27</b>	74	68	71	69	66	63	<b>27</b>			
		1600 (755)	0.040 (18.3)	74	69	71	70	68	66	<b>30</b>	75	70	72	71	69	67	<b>31</b>	75	70	72	71	69	67	<b>31</b>			
		1800 (849)	0.050 (23.2)	74	70	73	71	68	67	<b>31</b>	75	71	74	72	69	68	<b>32</b>	75	71	74	72	69	68	<b>32</b>			
		2000 (944)	0.062 (28.6)	76	73	74	74	72	71	<b>34</b>	77	74	75	75	73	72	<b>35</b>	77	74	75	75	73	72	<b>35</b>			
6	16	1600 (755)	0.030 (7.5)	68	66	72	67	65	66	<b>30</b>	69	67	73	68	66	67	<b>31</b>	69	67	73	68	66	67	<b>31</b>			
		1800 (849)	0.039 (9.7)	72	70	73	72	69	70	<b>33</b>	73	71	74	73	70	71	<b>34</b>	73	71	74	73	70	71	<b>34</b>			
		2000 (944)	0.048 (11.9)	74	72	74	73	71	71	<b>34</b>	75	73	75	74	72	72	<b>35</b>	75	73	75	74	72	72	<b>35</b>			
		2200 (1038)	0.058 (14.4)	75	73	75	73	73	73	<b>36</b>	76	74	76	74	74	74	<b>37</b>	76	74	76	74	74	74	<b>37</b>			
		2400 (1133)	0.069 (17.2)	77	75	76	75	75	75	<b>38</b>	78	76	77	76	76	76	<b>39</b>	78	76	77	76	76	76	<b>39</b>			
		2600 (1227)	0.081 (20.2)	79	77	77	79	78	78	<b>41</b>	80	78	78	80	79	79	<b>42</b>	80	78	78	80	79	79	<b>42</b>			
7	18x16	2200 (1038)	0.068 (17.0)	77	69	68	68	67	66	<b>30</b>	78	70	69	69	68	67	<b>31</b>	78	70	69	69	68	67	<b>31</b>			
		2500 (1180)	0.082 (20.5)	79	71	70	70	69	67	<b>32</b>	80	72	71	71	70	68	<b>34</b>	80	72	71	71	70	68	<b>34</b>			
		2700 (1274)	0.091 (22.8)	82	73	71	70	69	68	<b>36</b>	83	74	72	71	70	69	<b>38</b>	83	74	72	71	70	69	<b>38</b>			
		3000 (1416)	0.105 (26.1)	83	74	72	71	70	69	<b>38</b>	84	75	73	72	71	70	<b>39</b>	84	75	73	72	71	70	<b>39</b>			
		4000 (1888)	0.151 (37.6)	86	78	76	75	75	72	<b>41</b>	87	79	77	76	76	73	<b>43</b>	87	79	77	76	76	73	<b>43</b>			
		4400 (2076)	0.163 (40.5)	87	79	77	77	77	74	<b>43</b>	88	80	78	78	78	75	<b>44</b>	88	80	78	78	78	75	<b>44</b>			

**NOTE 1:** Performance data contained within a bold border outline are AHRI certified data.

**NOTE 2:** Performance data not contained within a bold border outline are application ratings. Application ratings are outside the scope of the Certification Program.

**NOTE 3:** Performance data is obtained from laboratory testing in accordance with AHRI 880-2011 and ANSI/ASHRAE 130-2008.

**NOTE 4:** NC values are calculated using attenuation credits outlined in Appendix E of AHRI 885-2008.

**NOTE 5:** Air terminal units were tested with an external static pressure of 0.25 in.w.g.

**NOTE 6:** Discharge Sound power levels shown with End Reflection Corrections Included in dB (ref: 10<sup>-12</sup> watts).

**NOTE 7:** Minimum Ps is the static pressure drop across the air terminal unit while the inlet damper is in the wide-open position at a given airflow rate and the fan is on.

**Table 42: MQFCI-600 ECM Discharge Sound Power Level at Inlet Ps = 1.0, 1.5, and 2.0 in.w.g.**

Case Size	Inlet Size (in)	CFM (L/s)	Min Ps in.w.g. (Pa)	Fan Only							Inlet Ps = 0.50 in.w.g. (125 Pa)							Inlet Ps = 0.75 in.w.g. (187 Pa)									
				Octave Band Sound Power, Lw, dB							NC	Octave Band Sound Power, Lw, dB							NC	Octave Band Sound Power, Lw, dB							NC
				2	3	4	5	6	7	2		3	4	5	6	7	2	3		4	5	6	7				
2	8	200 (94)	0.007 (1.6)	55	58	56	47	44	39	<b>16</b>	56	59	57	48	45	40	<b>18</b>	56	59	57	49	45	40	<b>18</b>			
		300 (142)	0.017 (4.2)	57	59	58	49	47	43	<b>16</b>	58	60	59	50	48	44	<b>18</b>	58	60	59	51	48	44	<b>18</b>			
		400 (189)	0.031 (7.7)	59	60	59	51	50	46	<b>18</b>	60	61	60	52	51	47	<b>19</b>	60	61	60	52	51	47	<b>19</b>			
		500 (236)	0.045 (11.2)	60	61	60	52	51	47	<b>19</b>	61	62	61	53	52	48	<b>20</b>	61	62	61	53	52	48	<b>20</b>			
		600 (283)	0.076 (18.9)	62	62	61	53	52	48	<b>20</b>	63	63	62	54	53	49	<b>21</b>	63	63	62	54	53	49	<b>21</b>			
		750 (354)	0.110 (27.4)	64	64	62	54	53	50	<b>21</b>	65	65	63	55	54	51	<b>22</b>	65	65	63	55	54	51	<b>22</b>			
3	10	300 (142)	0.006 (1.4)	60	58	62	55	51	49	<b>15</b>	61	59	63	56	52	50	<b>17</b>	61	59	63	56	52	50	<b>17</b>			
		400 (189)	0.010 (2.6)	61	60	62	57	54	51	<b>18</b>	62	61	63	58	55	52	<b>19</b>	62	61	63	58	55	52	<b>19</b>			
		500 (236)	0.016 (4.0)	62	60	62	58	55	52	<b>18</b>	63	61	63	59	56	53	<b>19</b>	63	61	63	59	56	53	<b>19</b>			
		600 (283)	0.023 (5.8)	62	61	62	59	56	54	<b>19</b>	63	62	63	60	57	55	<b>20</b>	63	62	63	60	57	55	<b>20</b>			
		700 (330)	0.032 (7.9)	63	62	62	60	57	55	<b>20</b>	64	63	63	61	58	56	<b>21</b>	64	63	63	61	58	56	<b>21</b>			
		800 (378)	0.041 (10.3)	65	64	62	62	60	58	<b>22</b>	66	65	63	63	61	59	<b>23</b>	66	65	63	63	61	59	<b>23</b>			
		900 (425)	0.052 (13.0)	66	65	63	64	62	60	<b>24</b>	67	66	64	65	63	61	<b>25</b>	67	66	64	65	63	61	<b>25</b>			
4	12	400 (189)	0.004 (0.3)	62	60	55	54	53	49	<b>18</b>	63	61	56	55	54	50	<b>19</b>	63	62	56	55	54	50	<b>20</b>			
		600 (283)	0.010 (0.6)	64	62	59	57	56	53	<b>20</b>	65	63	60	58	57	54	<b>21</b>	65	64	60	58	57	54	<b>22</b>			
		800 (378)	0.018 (1.2)	65	66	60	58	58	55	<b>24</b>	66	67	61	59	59	56	<b>25</b>	66	68	61	59	59	56	<b>26</b>			
		1000 (472)	0.028 (2.0)	66	69	62	62	62	60	<b>27</b>	67	70	63	63	63	61	<b>28</b>	67	71	63	63	63	61	<b>29</b>			
		1200 (566)	0.040 (3.5)	67	72	66	65	65	64	<b>31</b>	68	73	67	66	66	65	<b>32</b>	68	74	67	66	66	65	<b>33</b>			
		1400 (661)	0.054 (5.7)	69	73	67	68	69	68	<b>32</b>	70	74	68	69	70	69	<b>33</b>	70	75	68	69	70	69	<b>34</b>			
		1600 (755)	0.071 (9.2)	72	74	71	70	72	70	<b>33</b>	73	75	72	71	73	71	<b>34</b>	73	76	72	71	73	71	<b>35</b>			
		1000 (472)	0.015 (7.2)	70	62	65	62	60	55	<b>21</b>	71	63	66	63	61	56	<b>22</b>	71	63	66	63	61	56	<b>22</b>			
5	14	1200 (566)	0.022 (10.3)	72	64	69	65	62	59	<b>23</b>	73	65	70	66	63	60	<b>25</b>	73	65	70	66	63	60	<b>25</b>			
		1400 (661)	0.030 (14.0)	73	67	70	68	65	62	<b>26</b>	74	68	71	69	66	63	<b>27</b>	74	68	71	69	66	63	<b>27</b>			
		1600 (755)	0.040 (18.3)	74	69	71	70	68	66	<b>30</b>	75	70	72	71	69	67	<b>31</b>	75	70	72	71	69	67	<b>31</b>			
		1800 (849)	0.050 (23.2)	74	70	73	71	68	67	<b>31</b>	75	71	74	72	69	68	<b>32</b>	75	71	74	72	69	68	<b>32</b>			
		2000 (944)	0.062 (28.6)	76	73	74	74	72	71	<b>34</b>	77	74	75	75	73	72	<b>35</b>	77	74	75	75	73	72	<b>35</b>			
				1600 (755)	0.030 (7.5)	68	66	72	67	65	66	<b>30</b>	69	67	73	68	66	67	<b>31</b>	69	67	73	68	66	67	<b>31</b>	
6	16	1800 (849)	0.039 (9.7)	72	70	73	72	69	70	<b>33</b>	73	71	74	73	70	71	<b>34</b>	73	71	74	73	70	71	<b>34</b>			
		2000 (944)	0.048 (11.9)	74	72	74	73	71	71	<b>34</b>	75	73	75	74	72	72	<b>35</b>	75	73	75	74	72	72	<b>35</b>			
		2200 (1038)	0.058 (14.4)	75	73	75	73	73	73	<b>36</b>	76	74	76	74	74	74	<b>37</b>	76	74	76	74	74	74	<b>37</b>			
		2400 (1133)	0.069 (17.2)	77	75	76	75	75	75	<b>38</b>	78	76	77	76	76	76	<b>39</b>	78	76	77	76	76	76	<b>39</b>			
		2600 (1227)	0.081 (20.2)	79	77	77	79	78	78	<b>41</b>	80	78	78	80	79	79	<b>42</b>	80	78	78	80	79	79	<b>42</b>			
7	18x16	2200 (1038)	0.068 (17.0)	77	69	68	68	67	66	<b>30</b>	78	70	69	69	68	67	<b>31</b>	78	70	69	69	68	67	<b>31</b>			
		2500 (1180)	0.082 (20.5)	79	71	70	70	69	67	<b>32</b>	80	72	71	71	70	68	<b>34</b>	80	72	71	71	70	68	<b>34</b>			
		2700 (1274)	0.091 (22.8)	82	73	71	70	69	68	<b>36</b>	83	74	72	71	70	69	<b>38</b>	83	74	72	71	70	69	<b>38</b>			
		3000 (1416)	0.105 (26.1)	83	74	72	71	70	69	<b>38</b>	84	75	73	72	71	70	<b>39</b>	84	75	73	72	71	70	<b>39</b>			
		4000 (1888)	0.151 (37.6)	86	78	76	75	75	72	<b>41</b>	87	79	77	76	76	73	<b>43</b>	87	79	77	76	76	73	<b>43</b>			
		4400 (2076)	0.163 (40.5)	87	79	77	77	77	74	<b>43</b>	88	80	78	78	78	75	<b>44</b>	88	80	78	78	78	75	<b>44</b>			

- NOTE 1:** Performance data contained within a bold border outline are AHRI certified data.
- NOTE 2:** Performance data not contained within a bold border outline are application ratings. Application ratings are outside the scope of the Certification Program.
- NOTE 3:** Performance data is obtained from laboratory testing in accordance with AHRI 880-2011 and ANSI/ASHRAE 130-2008.
- NOTE 4:** NC values are calculated using attenuation credits outlined in Appendix E of AHRI 885-2008.
- NOTE 5:** Air terminal units were tested with an external static pressure of 0.25 in.w.g.
- NOTE 6:** Discharge Sound power levels shown with End Reflection Corrections Included in dB (ref: 10<sup>-12</sup> watts).
- NOTE 7:** Minimum Ps is the static pressure drop across the air terminal unit while the inlet damper is in the wide-open position at a given airflow rate and the fan is on.

**Table 43: MQFCI-600 Minimum Pressures**

Case Size	CFM	Unit ΔPs (in.w.g.) [no coil]	Unit ΔPt (in.w.g.) [no coil]	Unit + 1R Coil, ΔPs (in.w.g.)	Unit + 1R Coil, ΔPt (in.w.g.)	Unit + 2R Coil, ΔPs (in.w.g.)	Unit + 2R Coil, ΔPt (in.w.g.)
2	200	0.01	0.02	0.02	0.03	0.03	0.04
	300	0.02	0.05	0.03	0.06	0.05	0.08
	400	0.03	0.10	0.05	0.12	0.08	0.15
	500	0.05	0.15	0.08	0.18	0.12	0.22
	600	0.08	0.23	0.12	0.27	0.18	0.33
	750	0.11	0.35	0.16	0.40	0.24	0.48
3	300	0.01	0.05	0.02	0.06	0.03	0.07
	400	0.01	0.08	0.02	0.09	0.04	0.11
	500	0.02	0.06	0.04	0.08	0.06	0.10
	600	0.02	0.08	0.04	0.10	0.07	0.13
	700	0.03	0.11	0.07	0.15	0.12	0.20
	800	0.04	0.15	0.09	0.20	0.14	0.25
4	600	0.00	0.07	0.02	0.09	0.05	0.12
	800	0.00	0.05	0.05	0.10	0.10	0.15
	1000	0.00	0.08	0.06	0.14	0.12	0.20
	1200	0.01	0.12	0.09	0.20	0.18	0.29
	1400	0.02	0.17	0.12	0.27	0.24	0.39
	1600	0.03	0.23	0.16	0.36	0.30	0.50
5	800	0.01	0.06	0.06	0.11	0.11	0.16
	1000	0.01	0.10	0.07	0.16	0.13	0.22
	1200	0.01	0.07	0.09	0.15	0.18	0.24
	1400	0.01	0.10	0.11	0.20	0.23	0.32
	1600	0.02	0.13	0.15	0.26	0.29	0.40
6	800	0.00	0.03	0.03	0.06	0.07	0.10
	1000	0.00	0.05	0.05	0.10	0.11	0.16
	1200	0.00	0.07	0.07	0.14	0.14	0.21
	1400	0.00	0.09	0.09	0.18	0.19	0.28
	1600	0.00	0.12	0.11	0.23	0.23	0.35
	1800	0.01	0.09	0.14	0.22	0.29	0.37
7	1600	0.04	0.12	0.07	0.15	0.11	0.19
	2000	0.06	0.18	0.11	0.23	0.17	0.29
	2400	0.08	0.25	0.15	0.32	0.23	0.40
	2800	0.10	0.33	0.19	0.42	0.29	0.52
	3200	0.12	0.42	0.23	0.53	0.36	0.66
	3600	0.13	0.52	0.26	0.65	0.42	0.81

- NOTE 1:** ΔPs = static pressure drop; ΔPt = total pressure drop.
- NOTE 2:** Calculations of ΔPs and ΔPt were performed using standard air with a density of 0.075 lb m/cu ft.
- NOTE 3:** Data based on testing standard Daikin Applied hot water coils per AHRI Standard 410.
- NOTE 4:** Unit ΔPs and Unit ΔPt are pressure drops across the air terminal unit while the inlet damper is in the wide-open position.
- NOTE 5:** Data applies to air terminal units with hot water coil mounted on the discharge side.

**Table 44: MQFCI-600 ECM Amperage Ratings**

Case Size	Motor HP	ECM Amperage Ratings		
		115V-1 Phase 60 Hz Rated Amps	208-240V-1 Phase 60 Hz Rated Amps	277V-1 Phase 60 Hz Rated Amps
2	1/3	4.7	3	2.4
3	1/3	4.7	3	2.4
4	1/2	6.6	4.2	3.4
5	1	12	7.5	6.2
6	1	12	7.5	6.2
7	1 (Qty 2)	12 (Each)	7.5 (Each)	6.2 (Each)

**Table 45: MQFCI-600 ECM Damper Leakage**

Inlet Size (in)	Damper Leakage, CFM		
	1.5" ΔPs	3.0" ΔPs	6.0" ΔPs
6	3	4	7
8	2	4	7
10	4	5	7
12	4	5	7
14	4	6	8
16	4	6	8

**Table 46: MQFCI-600 Hot Water Coils MBH Selection Data – Imperial Units**

Case Size	Rows	Connection (OD)	GPM	Head Loss (ft-H <sub>2</sub> O)	CFM							
					300	350	400	450	500	550	600	700
2	One	0.875	1	0.14	12.7	13.5	14.3	15.0	15.6	16.2	16.7	17.6
			2	0.54	14.3	15.4	16.5	17.4	18.2	19.0	19.7	21.1
			4	2.06	15.3	16.6	17.8	18.9	20.0	20.9	21.8	23.4
			6	4.52	15.7	17.1	18.4	19.5	20.6	21.6	22.6	24.3
			Airsides Ps		0.01	0.02	0.02	0.03	0.03	0.04	0.04	0.06
2	Two	0.875	1	0.09	17.8	19.1	20.3	21.3	22.2	23.0	23.7	25.0
			2	0.34	20.9	22.9	24.6	26.2	27.6	28.9	30.1	32.2
			4	1.32	23.0	25.4	27.6	29.6	31.5	33.2	34.8	37.8
			6	2.94	23.8	26.4	28.8	31.0	33.0	35.0	36.8	40.1
			Airsides Ps		0.03	0.04	0.05	0.06	0.07	0.09	0.10	0.13
					CFM							
					400	450	500	550	600	700	800	900
3	One	0.625	1	0.20	16.8	17.6	18.4	19.1	19.8	20.9	21.9	22.7
			2	0.75	19.3	20.5	21.5	22.5	23.4	25.1	26.6	27.9
			4	2.88	20.9	22.3	23.5	24.8	25.9	27.9	29.8	31.4
			6	6.30	21.5	23.0	24.3	25.6	26.8	29.0	31.1	32.9
			Airsides Ps		0.01	0.01	0.02	0.02	0.02	0.03	0.04	0.05
3	Two	0.875	1	0.10	22.9	24.1	25.3	26.2	27.1	28.7	30.0	31.1
			2	0.39	27.7	29.6	31.3	32.9	34.4	37.1	39.4	41.4
			4	1.52	30.9	33.3	35.6	37.7	39.7	43.3	46.6	49.6
			6	3.36	32.1	34.8	37.2	39.6	41.8	45.9	49.7	53.1
			Airsides Ps		0.03	0.03	0.04	0.05	0.05	0.07	0.09	0.10
					CFM							
					800	900	1000	1100	1200	1300	1400	1500
4	One	0.625	1	0.20	21.9	22.7	23.5	24.2	24.8	25.3	25.9	26.3
			2	0.76	26.6	27.9	29.1	30.1	31.1	32.0	32.9	33.6
			4	2.88	29.8	31.4	33.0	34.4	35.7	36.9	38.0	39.1
			6	6.31	31.1	32.9	34.6	36.1	37.5	38.9	40.2	41.4
			Airsides Ps		0.04	0.05	0.06	0.07	0.08	0.09	0.1	0.11
4	Two	0.875	1	0.10	30.0	31.1	32.1	32.9	33.6	34.3	34.9	35.4
			2	0.39	39.4	41.4	43.3	44.9	46.4	47.7	49.0	50.1
			4	1.52	46.6	49.6	52.3	54.8	57.1	59.2	61.2	63.0
			6	3.36	49.7	53.1	56.2	59.1	61.8	64.3	66.7	68.9
			Airsides Ps		0.09	0.10	0.12	0.15	0.17	0.19	0.22	0.24
					CFM							
					1200	1350	1475	1600	1725	1850	1975	2000
5	One	0.625	1	0.20	24.8	25.6	26.2	26.7	27.2	27.7	28.1	28.2
			2	0.76	31.1	32.4	33.4	34.4	35.2	36.0	36.7	36.9
			4	2.89	35.7	37.5	38.8	40.1	41.3	42.4	43.4	43.6
			6	6.32	37.5	39.5	41.1	42.5	43.8	45.1	46.2	46.5
			Airsides Ps		0.08	0.09	0.11	0.13	0.14	0.16	0.18	0.19
5	Two	0.875	1	0.10	33.6	34.6	35.3	35.9	36.5	37.0	37.4	37.5
			2	0.39	46.4	48.4	49.8	51.2	52.4	53.5	54.5	54.7
			4	1.52	57.1	60.2	62.5	64.7	66.8	68.6	70.4	70.7
			6	3.36	61.8	65.5	68.4	71.0	73.5	75.8	77.9	78.4
			Airsides Ps		0.17	0.20	0.24	0.27	0.31	0.35	0.39	0.39
					CFM							
					1800	1900	2000	2100	2200	2300	2400	2600
6	One	0.625	1	0.21	28.7	29.1	29.4	29.7	30.0	30.3	30.6	31.1
			2	0.81	37.4	38.0	38.7	39.2	39.8	40.3	40.8	41.7
			4	3.08	44.0	45.0	45.8	46.6	47.4	48.2	48.9	50.3
			6	6.73	46.8	47.9	48.9	49.8	50.7	51.6	52.4	54.0
			Airsides Ps		0.13	0.14	0.16	0.17	0.19	0.2	0.22	0.25
6	Two	0.875	1	0.10	38.0	38.4	38.8	39.0	39.4	39.7	40.0	40.4
			2	0.40	55.0	55.9	56.8	57.6	58.4	59.0	59.7	60.9
			4	1.57	70.6	72.2	73.7	75.1	76.4	77.6	78.8	81.1
			6	3.47	78.0	79.9	81.7	83.4	85.1	86.6	88.2	91.0
			Airsides Ps		0.28	0.31	0.34	0.36	0.39	0.43	0.46	0.52
					CFM							
					2400	2600	2800	3000	3200	3400	3600	4000
7	One	0.875	2	0.37	51.4	52.6	53.6	54.6	55.5	56.3	57.1	58.5
			4	1.43	64.7	66.6	68.4	70.0	71.5	73.0	74.3	76.8
			6	3.18	70.8	73.1	75.2	77.2	79.1	80.9	82.6	85.7
			8	3.65	74.3	76.8	79.2	81.5	83.6	85.6	87.5	91.0
			Airsides Ps		0.07	0.08	0.09	0.1	0.11	0.12	0.13	0.16
7	Two	0.875	2	0.27	71.9	73.4	74.7	75.9	77.0	78.0	78.9	80.5
			4	1.07	98.7	101.7	104.5	107.0	109.4	111.6	113.6	117.3
			6	2.39	112.2	116.2	119.9	123.3	126.6	129.6	132.4	137.6
			8	4.22	120.3	125.0	129.3	133.4	137.2	140.9	144.3	150.5
			Airsides Ps		0.15	0.17	0.19	0.21	0.24	0.26	0.29	0.34

**NOTE:** Heating capacity data in tables assume an entering water temperature (EWT) of 180°F, and an entering air temperature (EAT) of 65°F, which corresponds to a temperature difference of 115°F. Smaller temperature differences will result in a decrease of heating capacity. To obtain the heating capacity at another temperature difference, refer to the hot water coil notes located in the Reference Section.

**Table 47: MQFCI-600 Hot Water Coils MBH Selection Data – Metric Units**

Case Size	Rows	Connection OD (mm)	Water Flow (L/s)	Head Loss (kPa)	Airflow (L/s)							
					142	165	189	212	236	260	283	330
2	One	22.2	0.01	0.42	3.7	4.0	4.2	4.4	4.6	4.7	4.9	5.2
			0.03	1.61	4.2	4.5	4.8	5.1	5.3	5.6	5.8	6.2
			0.13	6.16	4.5	4.9	5.2	5.5	5.9	6.1	6.4	6.9
			0.29	13.51	4.6	5.0	5.4	5.7	6.0	6.3	6.6	7.1
			Airsides Ps (kPa)		0.002	0.005	0.005	0.007	0.007	0.010	0.010	0.015
2	Two	22.2	0.01	0.27	5.2	5.6	5.9	6.2	6.5	6.7	6.9	7.3
			0.02	1.02	6.1	6.7	7.2	7.7	8.1	8.5	8.8	9.4
			0.08	3.95	6.7	7.4	8.1	8.7	9.2	9.7	10.2	11.1
			0.19	8.79	7.0	7.7	8.4	9.1	9.7	10.2	10.8	11.7
			Airsides Ps (kPa)		0.01	0.01	0.01	0.01	0.02	0.02	0.02	0.03
					Airflow (L/s)							
					189	212	236	260	283	330	378	425
3	One	15.9	0.01	0.60	4.9	5.2	5.4	5.6	5.8	6.1	6.4	6.6
			0.05	2.24	5.6	6.0	6.3	6.6	6.9	7.3	7.8	8.2
			0.18	8.61	6.1	6.5	6.9	7.2	7.6	8.2	8.7	9.2
			0.40	18.83	6.3	6.7	7.1	7.5	7.8	8.5	9.1	9.6
			Airsides Ps (kPa)		0.002	0.002	0.005	0.005	0.005	0.01	0.01	0.01
3	Two	22.2	0.01	0.30	6.7	7.1	7.4	7.7	7.9	8.4	8.8	9.1
			0.02	1.17	8.1	8.7	9.2	9.6	10.1	10.9	11.5	12.1
			0.10	4.54	9.0	9.7	10.4	11.0	11.6	12.7	13.6	14.5
			0.21	10.04	9.4	10.2	10.9	11.6	12.2	13.4	14.5	15.5
			Airsides Ps (kPa)		0.01	0.01	0.01	0.01	0.01	0.02	0.02	0.02
					Airflow (L/s)							
					378	425	472	519	566	614	661	708
4	One	15.9	0.01	0.60	6.4	6.7	6.9	7.1	7.3	7.4	7.6	7.7
			0.05	2.27	7.8	8.2	8.5	8.8	9.1	9.4	9.6	9.8
			0.18	8.61	8.7	9.2	9.7	10.1	10.5	10.8	11.1	11.4
			0.40	18.86	9.1	9.6	10.1	10.6	11.0	11.4	11.8	12.1
			Airsides Ps (kPa)		0.01	0.01	0.01	0.02	0.02	0.02	0.02	0.03
4	Two	22.2	0.01	0.30	8.8	9.1	9.4	9.6	9.8	10.0	10.2	10.4
			0.02	1.17	11.5	12.1	12.7	13.1	13.6	14.0	14.3	14.7
			0.10	4.54	13.6	14.5	15.3	16.0	16.7	17.3	17.9	18.4
			0.21	10.04	14.5	15.5	16.5	17.3	18.1	18.8	19.5	20.2
			Airsides Ps (kPa)		0.02	0.02	0.03	0.04	0.04	0.05	0.05	0.06
					Airflow (L/s)							
					566	637	696	755	814	873	932	944
5	One	15.9	0.01	0.60	7.3	7.5	7.7	7.8	8.0	8.1	8.2	8.3
			0.05	2.27	9.1	9.5	9.8	10.1	10.3	10.5	10.8	10.8
			0.18	8.64	10.5	11.0	11.4	11.7	12.1	12.4	12.7	12.8
			0.40	18.89	11.0	11.6	12.0	12.4	12.8	13.2	13.5	13.6
			Airsides Ps (kPa)		0.02	0.02	0.03	0.03	0.03	0.04	0.04	0.1
5	Two	22.2	0.01	0.30	9.8	10.1	10.3	10.5	10.7	10.8	11.0	11.0
			0.02	1.17	13.6	14.2	14.6	15.0	15.3	15.7	16.0	16.0
			0.10	4.54	16.7	17.6	18.3	18.9	19.5	20.1	20.6	20.7
			0.21	10.04	18.1	19.2	20.0	20.8	21.5	22.2	22.8	22.9
			Airsides Ps (kPa)		0.04	0.05	0.06	0.07	0.08	0.09	0.10	0.1
					Airflow (L/s)							
					850	897	944	991	1038	1085	1133	1227
6	One	15.9	0.01	0.63	8.4	8.5	8.6	8.7	8.8	8.9	9.0	9.1
			0.05	2.42	11.0	11.1	11.3	11.5	11.7	11.8	11.9	12.2
			0.19	9.21	12.9	13.2	13.4	13.6	13.9	14.1	14.3	14.7
			0.42	20.12	13.7	14.0	14.3	14.6	14.8	15.1	15.3	15.8
			Airsides Ps (kPa)		0.03	0.03	0.04	0.04	0.05	0.05	0.05	0.06
6	Two	22.2	0.01	0.30	11.1	11.2	11.3	11.4	11.5	11.6	9.94	10.06
			0.03	1.20	16.1	16.4	16.6	16.9	17.1	17.3	14.86	15.16
			0.10	4.69	20.7	21.1	21.6	22.0	22.4	22.7	19.62	20.17
			0.22	10.37	22.8	23.4	23.9	24.4	24.9	25.4	21.94	22.65
			Airsides Ps (kPa)		0.07	0.08	0.08	0.09	0.10	0.11	0.11	0.13
					Airflow (L/s)							
					1133	1227	1321	1416	1510	1605	1699	1888
7	One	22.2	0.02	1.11	15.0	15.4	15.7	16.0	16.3	16.5	16.7	17.1
			0.09	4.27	18.9	19.5	20.0	20.5	20.9	21.4	21.8	22.5
			0.20	9.51	20.7	21.4	22.0	22.6	23.2	23.7	24.2	25.1
			0.23	10.91	21.8	22.5	23.2	23.9	24.5	25.1	25.6	26.6
			Airsides Ps (kPa)		0.02	0.02	0.02	0.02	0.03	0.03	0.03	0.04
7	Two	22.2	0.02	0.81	21.1	21.5	21.9	22.2	22.5	22.8	19.64	20.03
			0.07	3.20	28.9	29.8	30.6	31.3	32.0	32.7	28.28	29.19
			0.15	7.14	32.9	34.0	35.1	36.1	37.1	37.9	32.95	34.26
			0.27	12.61	35.2	36.6	37.9	39.1	40.2	41.2	35.92	37.46
			Airsides Ps (kPa)		0.04	0.04	0.05	0.05	0.06	0.06	0.06	0.07

**NOTE:** Heating capacity data in tables assume an entering water temperature (EWT) of 82°C, and an entering air temperature (EAT) of 18°C, which corresponds to a temperature difference of 64°C. Smaller temperature differences will result in a decrease of heating capacity. To obtain the heating capacity at another temperature difference, refer to the hot water coil notes located in the Reference Section.



**Figure 13: MQFCI-600 ECM Fan Performance Curves, Case 2**

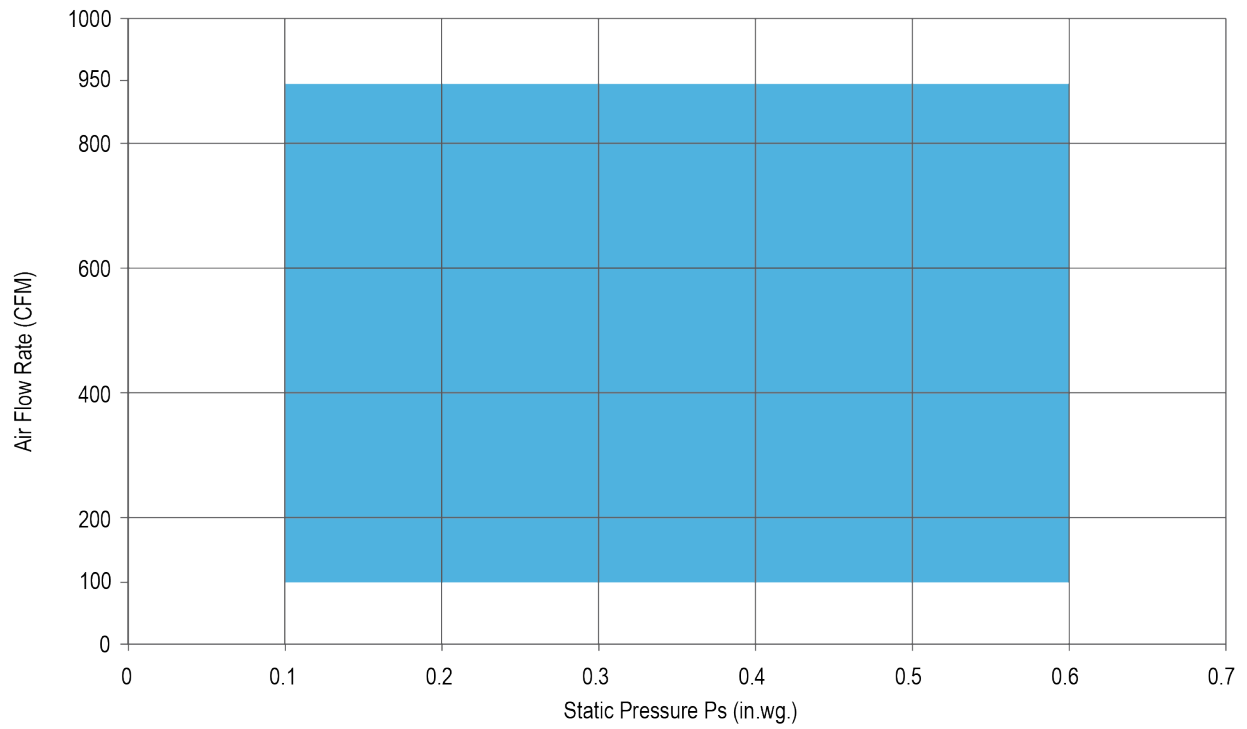

**Figure 14: MQFCI-600 ECM Fan Performance Curves, Case 3**

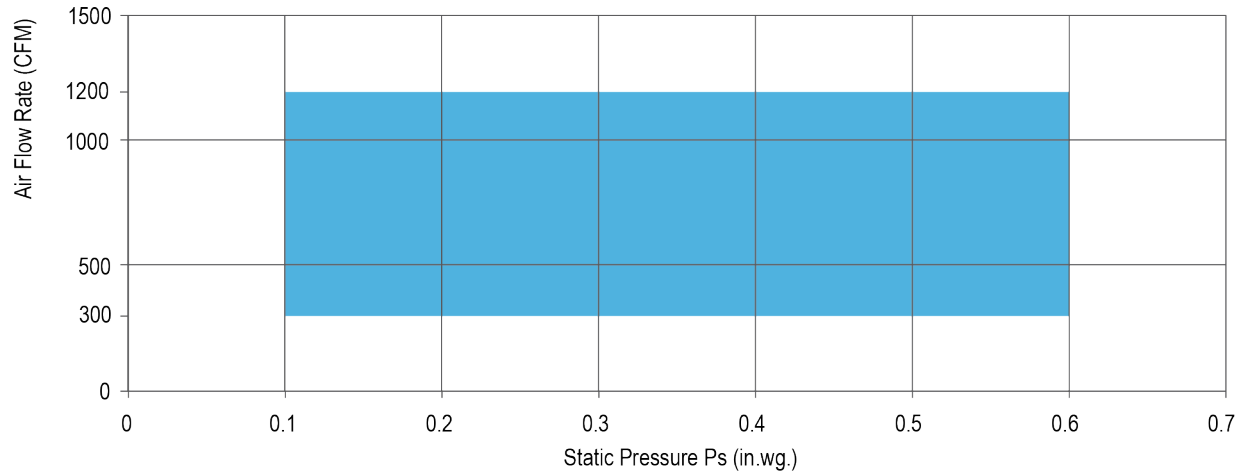

**Figure 15: MQFCI-600 ECM Fan Performance Curves, Case 4**

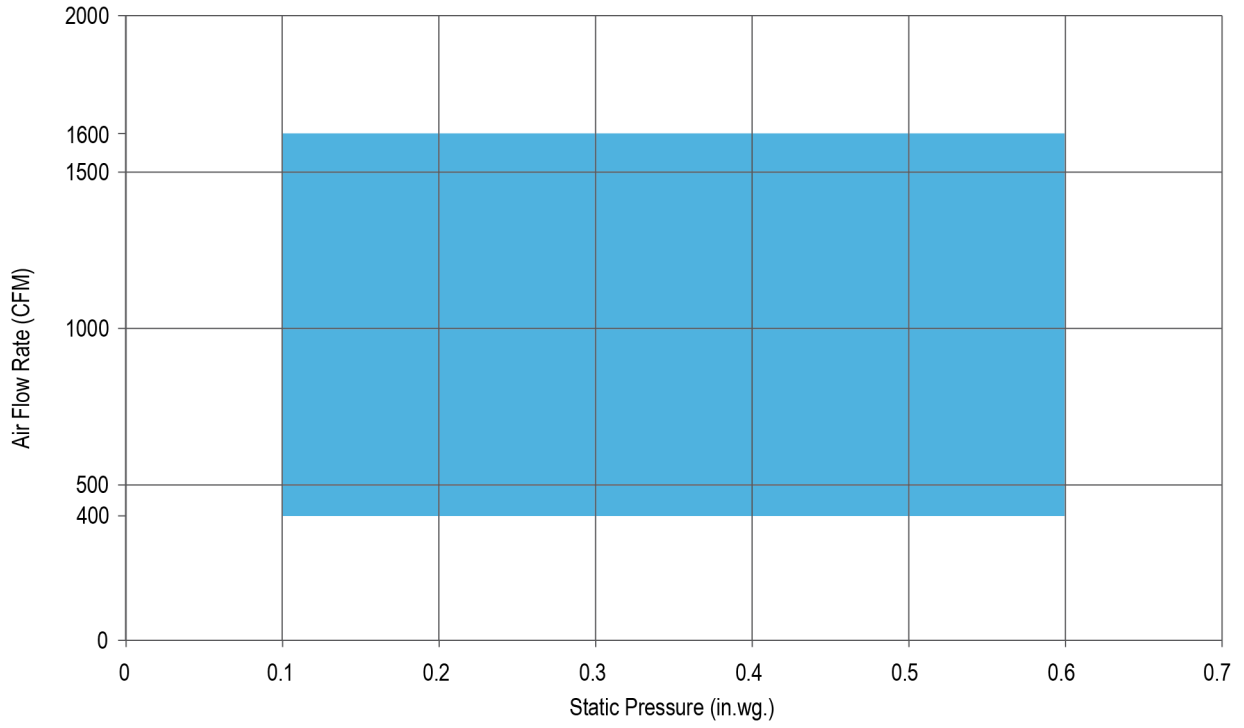

**Figure 16: MQFCI-600 ECM Fan Performance Curves, Case 5**

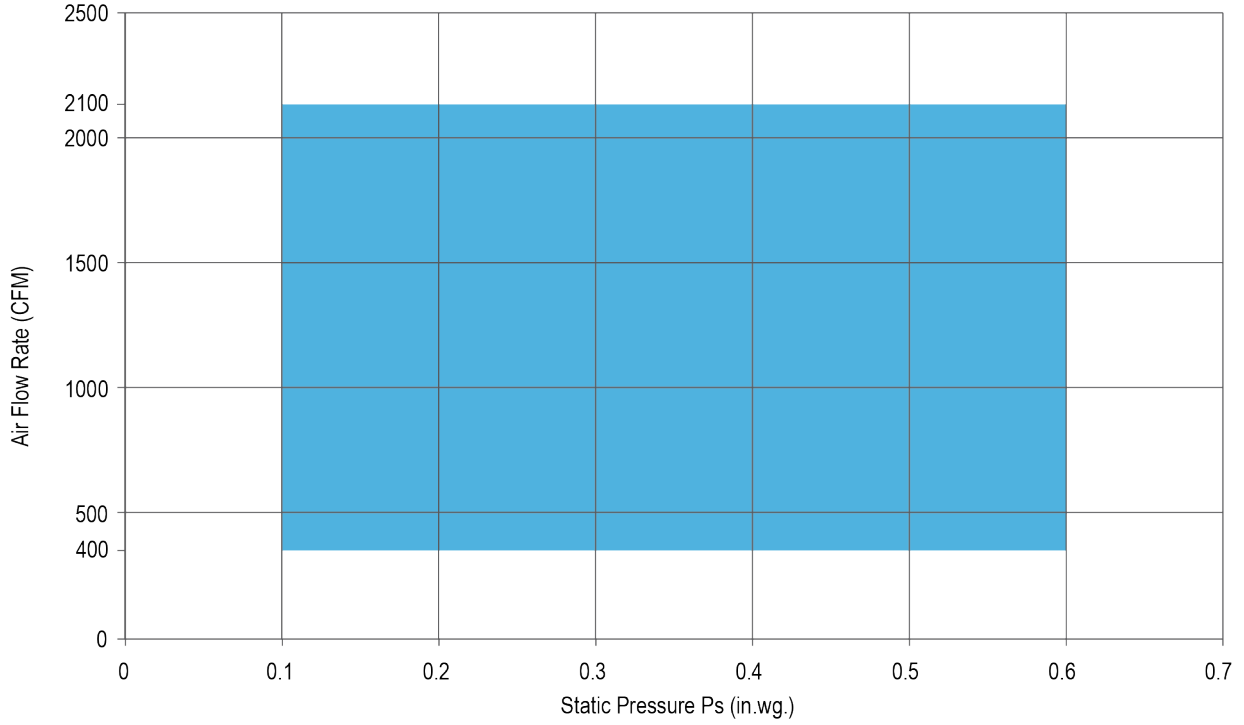

**Figure 17: MQFCI-600 ECM Fan Performance Curves, Case 6**

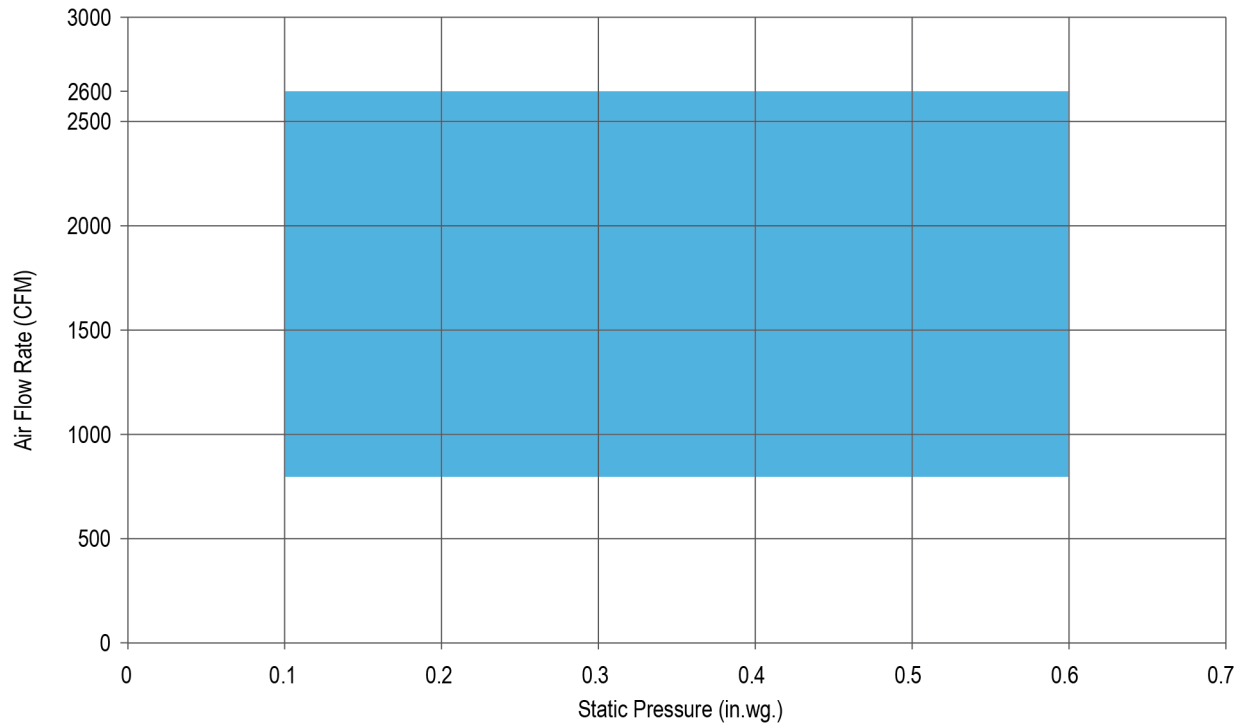

**Figure 18: MQFCI-600 ECM Fan Performance Curves, Case 7**

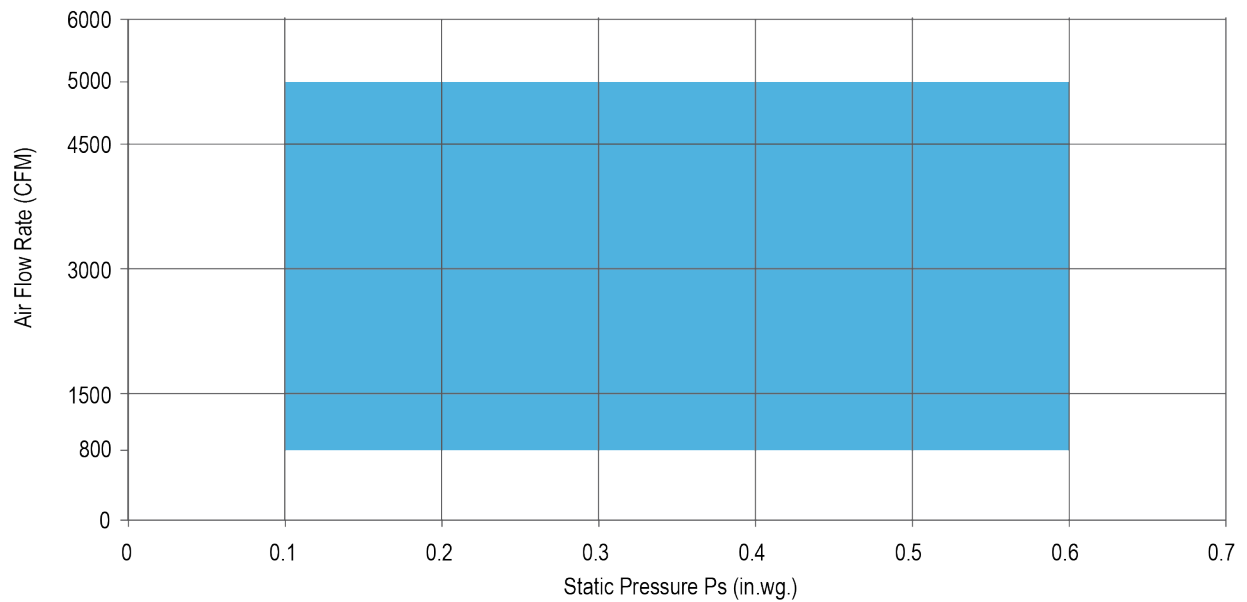

## Hot Water Coils

When ordered with the air terminal, the hot water coil is shipped attached to the discharge of the terminal casing. The discharge end of the casing has slip and drive connections for easy connection to downstream ductwork. The hot water coil is constructed of aluminum fin and copper serpentine-type tubes with male sweat connections tested at 300 psig.

Coil selection can be made using Daikin Select Tools selection software. Contact your Daikin Applied representative for a copy. In the interest of energy conservation and due to the possibility of condensation, all hot water coils are marked "Coil must be externally insulated after installation in the field." Hot water coils are tested in accordance with AHRI Standards 410. Hot water coils may be ordered with optional access doors for inspection and cleaning to meet requirements of ASHRAE Standard 62.1.

All accessories which can be attached to the Series Fan Boxes are not a part of the AHRI certification program but ratings can be affected by their use.

### Hot Water Coil Construction Details

- Hot Water Coils are factory mounted to the discharge of the terminal and are available with an optional factory mounted discharge plenum section with access door.
- Hot water coils are enclosed in a 20 gauge coated steel casing allowing for attachment to metal ductwork with a slip and drive connection.
- Fins are rippled and sine wave type constructed from heavy gauge aluminum and are mechanically bonded to the tubes.
- Tubes are copper with a minimum wall thickness of 0.016" with male solder header connections.
- Coils are leak tested to 300 psi with minimum burst of 2000 psi at ambient temperature. Coil performance data is based on tests run in accordance with AHRI standard 410. Coils are AHRI certified and include an AHRI label.

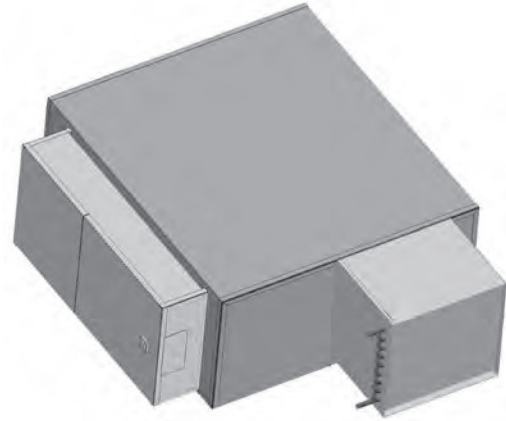

**Table 48: Hot Water Coil Tubing Connections**

Case Size	Standard HW Coil in (mm)	
	1 Row	2 Row
2	7/8 (22.2)	7/8 (22.2)
3	5/8 (15.8)	7/8 (22.2)
4	5/8 (15.8)	7/8 (22.2)
5	5/8 (15.8)	7/8 (22.2)
6	5/8 (15.8)	7/8 (22.2)
7	7/8 (22.2)	7/8 (22.2)

**NOTE:** All coils have 10 fins per inch.

**Table 49: Hot Water Coil Outlet Dimensions**

Case Size	Standard HW Coil in (mm)	
	H	W
2	15 (381)	16 (406)
3	17.5 (445)	20 (508)
4	17.5 (445)	20 (508)
5	17.5 (445)	20 (508)
6	18 (457)	22 (559)
7	20 (508)	38 (952)

## Electric Heat

Electric heater elements, as illustrated on this page, are integral to the air terminal. The discharge end has slip and drive connections for easy connection to downstream ductwork. ETL® listed heaters are provided with a fan interlock relay. Heaters that will be controlled electronically must include a 24 VAC control circuit to operate with the low voltage controls on the air terminal. Heater plenums are internally insulated. When an air terminal is ordered with clean room lining and electric heat, the heater plenum is either internally lined with optional foil backed insulation or closed cell foam or may require external insulation in field.

All accessories which can be attached to the Series Fan Boxes are not a part of the AHRI certification program but ratings can be affected by their use.

### Electric Heater Assembly Construction Details

- Electric Reheat Coils are factory mounted on the discharge of the Air Terminal. The heaters are ETL® listed for zero clearance, are tested in accordance with UL® Standard 1995, CSA-C22.2 No. 236 and the National Electric Code (NEC). Heater casings are constructed of heavy-duty zinc-coated steel. Element wire is high grade nichrome alloy derated to 45 watts per square inch density. Element wire is supported by moisture-resistant steatite ceramics.
- Ceramics are enclosed in reinforcement brackets spaced across the heater element rack at 2" to 4" intervals. Controls are contained in a NEMA 1 control cabinet with a hinged, latching door. A permanent wiring diagram is affixed to the inside of the control cabinet door for field reference.
- The 208 and 480 volt units require a neutral connection for both single and three phase service. Our standard motors are 120 and 277 volt single phase. The 208-240 volt single phase motor is optional. 480 volt motors are not available for our units. See [Table 50](#) for reference.

### Included with Each Heater Assembly:

- Heater and cabinet mounted on the discharge of the MQFCI-600
- Electric heater is interlocked into fan control relay
- De-energizing magnetic contactors per step
- Primary automatic reset high temperature limit (disc type)
- Backup manual reset high temperature limit (disc type)
- Non-fused transformer with voltage to match heater voltage
- Single-point power wiring connection
- Heater is shipped factory mounted and wired



**Table 50: Electric Heat Information**

Heater Voltage	Motor Voltage	Separate Neutral Required
120 V 1PH	120 V 1PH	NO
208 V 1PH	120 V 1PH	YES
277 V 1PH	277 V 1PH	NO
480 V 1PH	277 V 1PH	YES
208 V 1PH	208 V 1PH	NO
208 V 3PH	120 V 1PH	YES
480 V 3PH	277 V 1PH	YES
208 V 3PH	208 V 1PH	NO

**Table 51: MQFCI-600 Electric Heater Capacities**

Single Phase MQFCI kW Limits					Three Phase MQFCI kW Limits				
Case Size	Heater Voltage	Min. kW Step	Max. kW	Max. Steps	Case Size	Heater Voltage	Min. kW Step	Max. kW	Max. Step
2	120	0.5	5	3	2	208	0.5	13	3
2	208	0.5	8.5	3	2	240	0.5	14.5	3
2	240	0.5	10	3	2	480	1.5	17	3
2	277	0.5	11.5	3	3	208	0.5	13	3
2	480	0.5	11.5	3	3	240	0.5	14.5	3
3	120	0.5	5	3	3	480	1.5	17	3
3	208	0.5	8.5	3	4	208	0.5	13	3
3	240	0.5	10	3	4	240	1.5	15	3
3	277	0.5	11.5	3	4	480	1.5	25	3
3	480	0.5	11.5	3	5	208	0.5	13	3
4	120	0.5	5	3	5	240	1.5	15	3
4	208	0.5	8.5	3	5	480	1.5	25	3
4	240	0.5	10	3	6	208	0.5	13	3
4	277	0.5	11.5	3	6	240	1.5	15	3
4	480	0.5	17	3	6	480	1.5	25	3
5	120	0.5	5	3	7	208	0.5	13	3
5	208	0.5	8.5	3	7	240	1.5	15	3
5	240	0.5	10	3	7	480	1.5	25	3
5	277	0.5	11.5	3					
5	480	0.5	17	3					
6	120	0.5	5	3					
6	208	0.5	8.5	3					
6	240	0.5	10	3					
6	277	0.5	11.5	3					
6	480	0.5	17	3					
7	120	0.5	5	3					
7	208	0.5	8.5	3					
7	240	0.5	10	3					
7	277	0.5	11.5	3					
7	480	0.5	17	3					

- NOTE 1:** Heaters equal to or less than 5 kW are specifiable to the nearest 0.2 kW. Heaters less than 5 kW are specifiable to the nearest 0.2 kW. Heaters greater than 5 kW and less than 10.0 kW are specifiable to nearest 0.5 kW. Heaters greater than 10.0 kW are specifiable to nearest 1.0 kW.
- NOTE 2:** Minimum flow rate for electric heat is 70 CFM/kW. Lower CFM's can cause nuisance tripping, excessive discharge temperatures, rapid cycling and rapid element failure. Electric Heat units running below 70 CFM/kW will void all warranties.
- NOTE 3:** For optimum thermal comfort, the suggested discharge temperature should not exceed 20°F above room set point.
- NOTE 4:** We do not recommend discharge temperatures in excess of 115°F to protect heater coils.
- NOTE 5:** Maximum number of steps at minimum kW is one step.
- NOTE 6:** If more than 1 heater is wired into a building's circuit breaker (multi-outlet branch circuit), each heater will require the addition of power side fusing.

**Electric Heat Selection:**

- A. Specify electric duct heaters using voltage, kW, and number of steps.
- B. Use above chart to select voltage. Calculate required kW using following equations:

$$kW = \frac{BTU / HR}{3413} \quad kW = \frac{CFM \times \Delta \times 1.085}{3413} \quad \Delta = \frac{kW \times 3413}{CFM \times 1.085}$$

$$CFM = \frac{kW \times 3413}{\Delta \times 1.085} \quad CFM = \frac{kW \times 3413}{\Delta \times 1.085}$$

\* Air density at sea level—reduce by 0.036 for each 1000 feet of altitude above sea level

Where: BTU / Hr = Required heating capacity  
 CFM = volume of air during heating. Typically 100% of maximum cooling air volume  
 Δ = desired air temperature rise across the electric heater  
 Inlet air temperature = primary air temperature, usually 55°F

## Parallel Fan Powered Terminal Units - MQFVI-500 Variable Volume

Daikin Applied's parallel fan-powered terminal units are designed to provide superior comfort by intermittent parallel fan operation. Conditioned primary air is varied during cooling while the fan cycles on during heating. Parallel fan-powered terminal units allow for recovery of waste heat from the return plenum and a potential reduction in central fan energy, thereby lowering operating costs. In the heating mode with the fan energized, parallel fan-powered terminal units improve air circulation through better diffuser performance.

The primary function of the Daikin Applied parallel fan-powered terminal unit is to deliver variable volume, constant temperature primary air to the space in the cooling mode. The volume of supply air is varied in response to a control signal. In the heating mode, with the fan energized, the terminal unit mixes conditioned air and plenum air in response to a control signal to supply constant volume, variable temperature supply air into the space.

Supplemental heating is available in both electric heat and hot water coils if plenum heat is insufficient. With the demands of today's building designs to reduce energy in smaller mechanical spaces, the Daikin Applied parallel fan-powered terminal unit is the perfect choice.

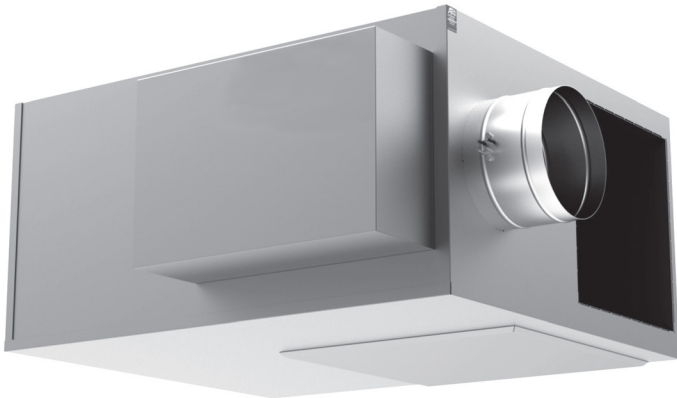

### Standard Features

- MQFVI-500 is available in 7 casing sizes to handle 150 – 5600 cfm
- 22 ga. galvanized steel casing, mechanically sealed, low leakage construction
- Damper constructed of double layer of 24 ga. galvanized steel with sandwiched flexible gasket to provide tight seal (<1% at 3" static pressure)
- Factory calibrated controls per each job requirement
- Multi-quadrant averaging flow sensor provides highly accurate +/- 5% flow readings after certified balancer has balanced terminal
- Easy access, steel balancing taps
- Standard highly efficient Electronically Commutated Motors (ECM)
- External control cabinet with offset mounting plate as standard
- Single point electrical connections
- 3-beaded primary inlet connection tube for added rigidity and secure flex duct connections
- Round inlets available in sizes 6" through 16"
- 1" thick, dual density (1.5lb/ft<sup>3</sup> min.) fiberglass insulation with edges coated. Meets NFPA 90A and UL 181
- Rectangular discharge with optional slip and drive duct connection
- Large removable bottom access panel provides complete access to interior of unit
- Independently tested and certified laboratory performance data
- Full range of options and accessories available (heating coils, disconnects, attenuators, etc.)
- Full range of liners/insulation available

## Components and Technology

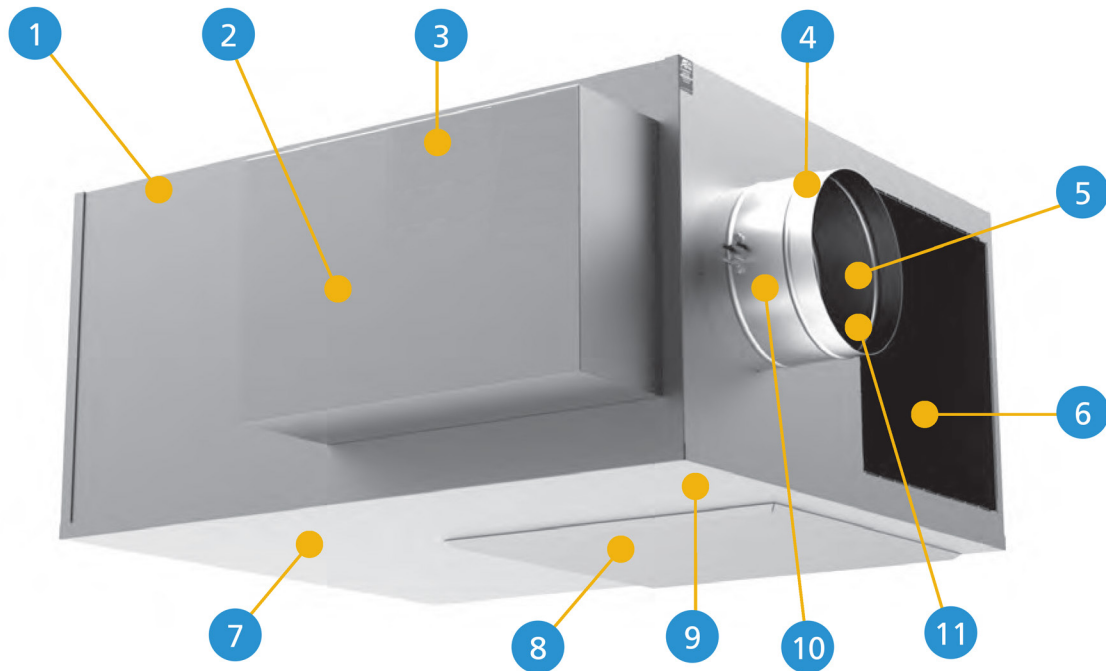

No.	Component	Description
1	Galvanized steel casing	Mechanically sealed for low leakage construction
2	NEMA 1 rated hinged control enclosure	With standoff to prevent penetration of casing
3	High efficiency ECM	Brushless-DC motor with built in speed and torque controls
4	Continuous welded primary inlet duct	Minimizes leakage with 3 stiffening beads for added rigidity and secure flex duct connections
5	Double layer 18 gauge damper construction	With mechanically fastened integral blade seal
6	Hand adjustable restrictor plates	Top and bottom for balancing
7	18 gauge bulkhead motor/blower assembly	Manufactured to mitigate vibration
8	Bottom access panel	For easy motor/blower servicing
9	Gasketed back draft damper door	Minimizes leakage in cooling mode
10	Multi-Quadrant averaging flow sensor	All metal construction inlet flow sensor with extra balancing taps
11	Durable damper assembly	Long life, low friction, self-lubricating thermoplastic bearing



# Dimensional Data

Figure 19: MQFVI-500 ECM Parallel Fan Powered Air Terminal Unit Cooling Only

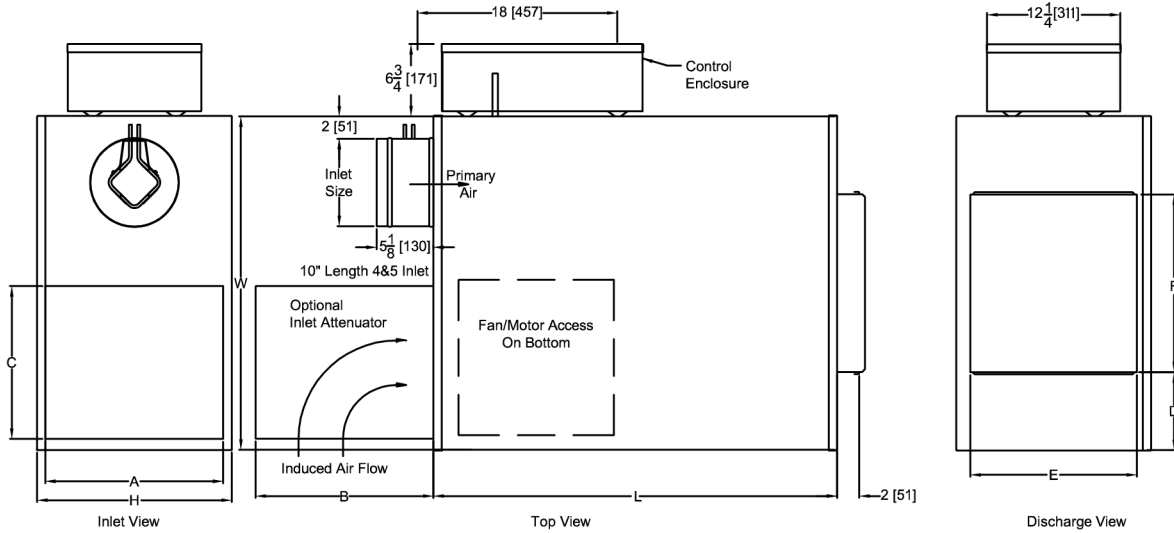

The standard location for control enclosure is Left Hand on Model MQFVI.  
Looking in the direction of airflow, the control enclosure is on the left.

Table 52: Unit Dimensions MQFVI-500 ECM Parallel Fan Powered Air Terminal Unit Cooling Only, in (mm)

Case Size	Inlet Size		Horsepower	Unit Dimensions			Induction Attenuator			Loc. D	Discharge	
	Standard	Optional		Height H	Width W	Length L	Height A	Width B	Length C		Height E	Width F
1	6 (152)	4, 5, 8, 10	1/3	17-1/2 (445)	30 (718)	36 (914)	14 (356)	16 (406)	14 (356)	8 (203)	13 (330)	14 (356)
2	8 (203)	4, 5, 6, 10, 12	1/3	17-1/2 (445)	30 (718)	36 (914)	14 (356)	16 (406)	14 (356)	8 (203)	13 (330)	14 (356)
3	10 (254)	4, 5, 6, 8, 12	1/2	17-1/2 (445)	36 (914)	40 (1016)	14 (356)	20 (508)	18 (457)	10 (254)	15-1/2 (394)	16 (406)
4	12 (305)	8, 10, 14	1/2	17-1/2 (445)	36 (914)	40 (1016)	14 (356)	20 (508)	18 (457)	10 (254)	15-1/2 (394)	16 (406)
5	14 (356)	10, 12, 16	1	20 (508)	40 (1016)	40 (1016)	16 (406)	20 (508)	18 (457)	11 (279)	15 (381)	18 (457)
6	16 (406)	10, 12, 14	1	20 (508)	42 (1067)	42 (1067)	16 (406)	24 (610)	20 (508)	11 (279)	16 (406)	20 (508)
7	16 (406)	12, 14	1	20 (508)	42 (1067)	42 (1067)	16 (406)	24 (610)	20 (508)	14 (356)	18 (457)	22 (559)

NOTE: "A" dimension will increase or decrease 1" as the inlet diameter increases or decreases 2" from the standard inlet diameter.

Figure 20: MQFVI-500 ECM Parallel Fan Powered Air Terminal Unit with Induction-Mounted Hot Water Coil

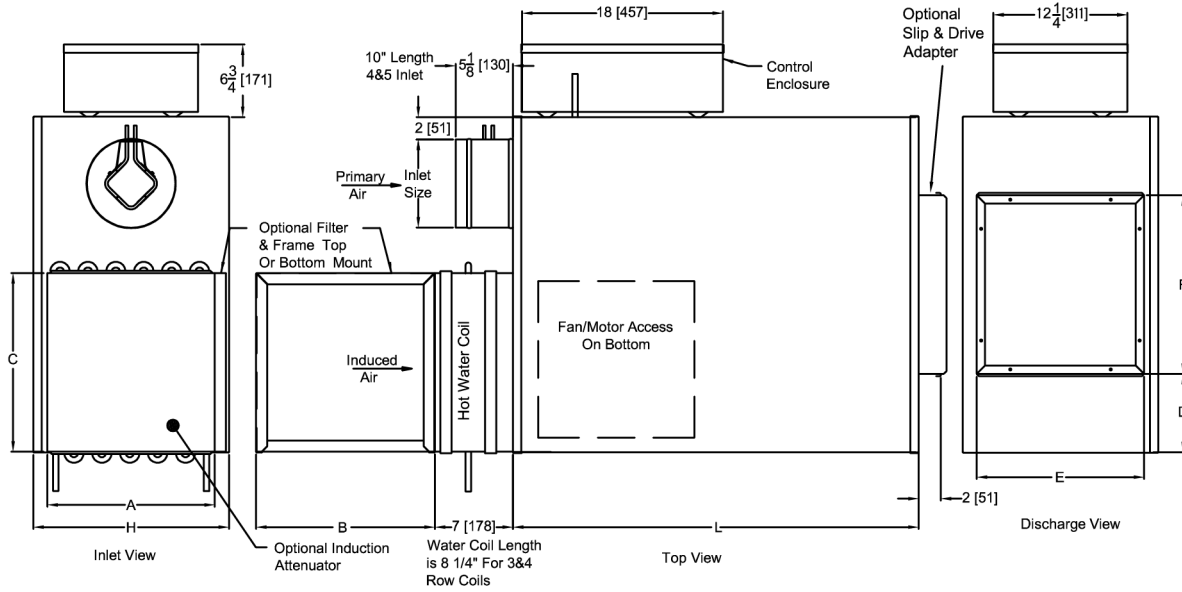

The standard location for control enclosure is Left Hand on Model MQFVI.  
Looking in the direction of airflow, the control enclosure is on the left.

Table 53: Unit Dimensions MQFVI-500 ECM Parallel Fan Powered Air Terminal Unit with Induction Mounted Hot Water Coil, in (mm)

Case Size	Inlet Size		Horsepower	Unit Dimensions			Induction Attenuator			Loc. D	Discharge	
	Standard	Optional		Height H	Width W	Length L	Height A	Width B	Length C		Height E	Width F
1	6 (152)	4, 5, 8, 10	1/3	17-1/2 (445)	30 (718)	36 (914)	15 (381)	16 (406)	16 (406)	8 (203)	13 (330)	14 (356)
2	8 (203)	4, 5, 6, 10, 12	1/3	17-1/2 (445)	30 (718)	36 (914)	15 (381)	16 (406)	16 (406)	8 (203)	13 (330)	14 (356)
3	10 (254)	4, 5, 6, 8, 12	1/2	17-1/2 (445)	36 (914)	40 (1016)	17-1/2 (445)	20 (508)	20 (508)	10 (254)	15-1/2 (394)	16 (406)
4	12 (305)	8, 10, 14	1/2	17-1/2 (445)	36 (914)	40 (1016)	17-1/2 (445)	20 (508)	20 (508)	10 (254)	15-1/2 (394)	16 (406)
5	14 (356)	10, 12, 16	1	20 (508)	40 (1016)	40 (1016)	17-1/2 (445)	20 (508)	20 (508)	11 (279)	15 (381)	18 (457)
6	16 (406)	10, 12, 14	1	20 (508)	42 (1067)	42 (1067)	18 (457)	24 (610)	22 (559)	11 (279)	16 (406)	20 (508)
7	16 (406)	12, 14	1	20 (508)	42 (1067)	42 (1067)	18 (457)	24 (610)	24 (610)	14 (356)	18 (457)	22 (559)

NOTE: "A" dimension will increase or decrease 1" as the inlet diameter increases or decreases 2" from the standard inlet diameter.

Figure 21: MQFVI-500 ECM Parallel Fan Powered Air Terminal Unit with Hot Water Coil Mounted on Discharge

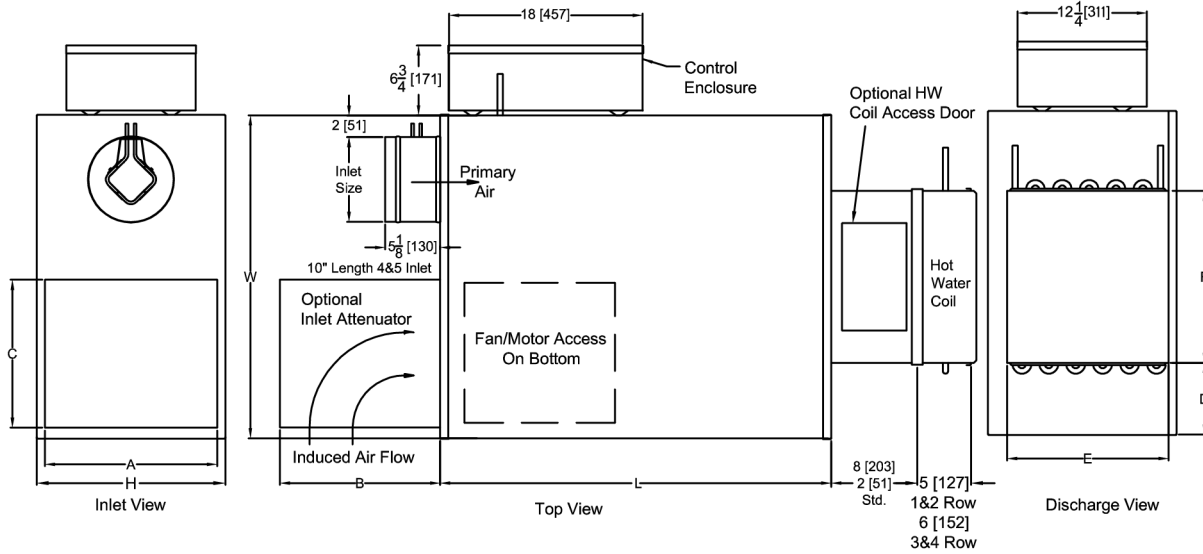

The standard location for control enclosure is Left Hand on Model MQFVI.  
Looking in the direction of airflow, the control enclosure is on the left.

Table 54: Unit Dimensions MQFVI-500 ECM Parallel Fan Powered Air Terminal Unit with Hot Water Coil Mounted on Discharge, in (mm)

Case Size	Inlet Size		Horsepower	Unit Dimensions			Induction Attenuator			Loc. D	Discharge	
	Standard	Optional		Height H	Width W	Length L	Height A	Width B	Length C		Height E	Width F
1	6 (152)	4, 5, 8, 10	1/3	17-1/2 (445)	30 (718)	36 (914)	14 (356)	16 (406)	14 (356)	7 (178)	15 (381)	16 (406)
2	8 (203)	4, 5, 6, 10, 12	1/3	17-1/2 (445)	30 (718)	36 (914)	14 (356)	16 (406)	14 (356)	7 (178)	15 (381)	16 (406)
3	10 (254)	4, 5, 6, 8, 12	1/2	17-1/2 (445)	36 (914)	40 (1016)	14 (356)	20 (508)	18 (457)	8 (203)	17-1/2 (445)	20 (508)
4	12 (305)	8, 10, 14	1/2	17-1/2 (445)	36 (914)	40 (1016)	14 (356)	20 (508)	18 (457)	8 (203)	17-1/2 (445)	20 (508)
5	14 (356)	10, 12, 16	1	20 (508)	40 (1016)	40 (1016)	16 (406)	20 (508)	18 (457)	10 (254)	17-1/2 (445)	20 (508)
6	16 (406)	10, 12, 14	1	20 (508)	42 (1067)	42 (1067)	16 (406)	24 (610)	20 (508)	10 (254)	18 (457)	22 (559)
7	16 (406)	12, 14	1	20 (508)	42 (1067)	42 (1067)	16 (406)	24 (610)	20 (508)	4-1/2 (114)	20 (508)	30 (762)

NOTE: "A" dimension will increase or decrease 1" as the inlet diameter increases or decreases 2" from the standard inlet diameter.

Figure 22: MQFVI-500 ECM Parallel Fan Powered Air Terminal Unit with Electric Heat

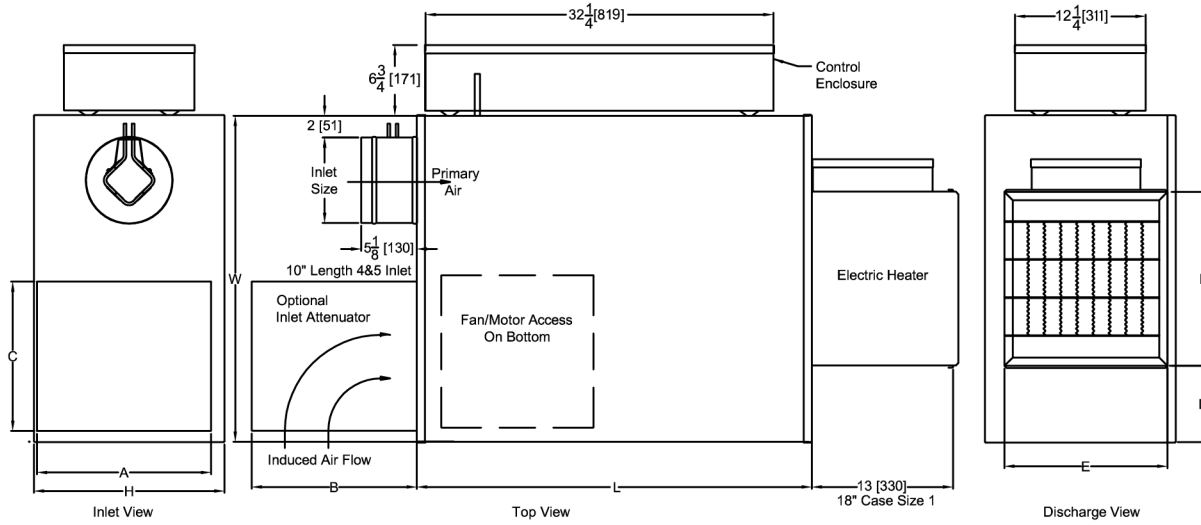

The standard location for control enclosure is Left Hand on Model MQFVI.  
Looking in the direction of airflow, the control enclosure is on the left.

Table 55: Unit Dimensions MQFVI-500 ECM Parallel Fan Powered Air Terminal Unit with Electric Heat, in (mm)

Case Size	Inlet Size		Horsepower	Unit Dimensions			Induction Attenuator			Loc. D	Discharge	
	Standard	Optional		Height H	Width W	Length L	Height A	Width B	Length C		Height E	Width F
1	6 (152)	4, 5, 8, 10	1/3	17-1/2 (445)	30 (718)	36 (914)	16 (406)	14 (356)	16 (406)	11 (279)	15 (381)	16 (406)
2	8 (203)	4, 5, 6, 10, 12	1/3	17-1/2 (445)	30 (718)	36 (914)	16 (406)	14 (356)	16 (406)	11 (279)	15 (381)	16 (406)
3	10 (254)	4, 5, 6, 8, 12	1/2	17-1/2 (445)	36 (914)	40 (1016)	16 (406)	18 (457)	20 (508)	13-1/8 (333)	15 (381)	16 (406)
4	12 (305)	8, 10, 14	1/2	17-1/2 (445)	36 (914)	40 (1016)	16 (406)	18 (457)	20 (508)	11-1/8 (283)	17-1/2 (445)	20 (508)
5	14 (356)	10, 12, 16	1	20 (508)	40 (1016)	40 (1016)	20 (508)	18 (457)	20 (508)	14-3/8 (365)	17-1/2 (445)	20 (508)
6	16 (406)	10, 12, 14	1	20 (508)	42 (1067)	42 (1067)	20 (508)	20 (508)	24 (610)	15-3/4 (400)	17-1/2 (445)	20 (508)
7	16 (406)	12, 14	1	20 (508)	42 (1067)	42 (1067)	20 (508)	20 (508)	24 (610)	6 (152)	20 (508)	30 (762)

NOTE: "A" dimension will increase or decrease 1" as the inlet diameter increases or decreases 2" from the standard inlet diameter.

Table 56: FCI-500 Approximate Shipping Weights

Case	FCI (lbs.)
1	120
2	124
3	165
4	165
5	198
6	220
7	220

NOTE: The weight is considering all the options that can be added to a box, including the weight of the boxes with different hot water or electric heat options. In the case of the hot water coil, water weight is not included.

Table 57: FCI-500 Filter Sizes per Case Size

Case Size	Filter Dimension (in)
1	16 x 16
2	16 x 16
3	20 x 16
4	20 x 16
5	20 x 20
6	24 x 20
7	24 x 20

NOTE: Filters are mounted on the fan induction and are available in 1" or 2" thicknesses.

# Performance Data

## MQFVI-500 AHRI Certified Rating Points

### Certifications and Standards

- Units tested per ANSI/ASHRAE Standard 130
- All model sizes certified in accordance with AHRI 880 certification program
- ETL listed to meet requirements of UL 1995 and CSA 236
- Dual-density fiberglass insulation meets UL 181 and NFPA 90A requirements
- Insulation meets ASHRAE 62.1 requirements for resistance to mold growth and erosion



**Table 58: MQFVI-500 AHRI Certified Radiated Sound Power, Fan Only**

Case Size	Inlet Size (in)	Fan CFM	Octave Band						Electrical Power (Watts)
			2	3	4	5	6	7	
1	6	270	65	60	52	45	42	41	140
2	8	440	63	58	48	41	37	35	170
3	10	780	66	62	55	49	43	44	300
4	12	1000	69	67	61	61	52	52	490
5	14	1200	68	61	58	50	49	48	630
6	16	1800	76	73	67	63	57	56	760
7	18	2600	77	74	71	69	62	61	1430

**Table 59: MQFVI-500 AHRI Certified Radiated Sound Power, Inlet Ps = 1.5 in.w.g. Static Pressure**

Case Size	Inlet Size (in)	Primary CFM	Min Ps	Octave Band					
				2	3	4	5	6	7
1	6	400	0.16	56	50	43	38	34	34
2	8	700	0.15	59	52	43	39	34	29
3	10	1100	0.16	63	54	50	47	41	35
4	12	1600	0.13	70	62	55	51	48	45
5	14	2100	0.14	66	61	52	48	43	36
6	16	2800	0.16	73	67	62	58	54	50
7	18	3750	0.13	77	71	68	65	61	56

**Table 60: MQFVI-500 AHRI Certified Discharge Sound Power, Fan Only**

Case Size	Inlet Size (in)	Fan CFM	Octave Band						Electrical Power (Watts)
			2	3	4	5	6	7	
1	6	270	63	58	52	50	46	41	140
2	8	440	62	56	52	53	47	40	170
3	10	780	69	62	58	57	54	50	300
4	12	1000	72	67	59	60	58	55	490
5	14	1200	64	63	59	57	54	53	630
6	16	1800	76	71	67	69	63	64	760
7	18	2600	81	77	75	73	70	73	1430

**Table 61: MQFVI-500 AHRI Certified Radiated Sound Power, Inlet Ps = 1.5 in.w.g. Static Pressure**

Case Size	Inlet Size (in)	Primary CFM	Min Ps	Octave Band					
				2	3	4	5	6	7
1	6	400	0.16	62	54	51	48	45	45
2	8	700	0.15	67	59	52	53	49	45
3	10	1100	0.16	69	62	57	56	53	50
4	12	1600	0.13	77	69	63	62	56	54
5	14	2100	0.14	73	67	61	61	58	52
6	16	2800	0.16	80	74	68	63	61	60
7	18	3750	0.13	85	82	77	76	74	74

**Table 62: MQFVI-500 Radiated Sound Power Level at Fan Only (Heating)**

Case Size	Inlet Size (in)	CFM (L/s)	Fan Only							
			Octave Band Sound Power, Lw, dB						NC	NC w/SA
			2	3	4	5	6	7		
1	6	150 (71)	59	44	48	43	36	35	22	20
		200 (94)	64	57	49	42	39	40	27	26
		250 (118)	65	59	52	44	41	41	29	27
		270 (127)	65	60	52	45	42	41	29	27
		300 (142)	66	61	53	46	43	42	31	29
		400 (189)	68	64	58	59	51	49	34	31
		450 (212)	70	66	64	64	55	53	39	34
2	8	250 (118)	56	51	42	37	33	32	19	16
		300 (142)	57	53	43	38	34	32	21	17
		350 (165)	60	56	46	40	36	34	25	21
		400 (189)	62	57	47	41	37	35	26	23
		440 (208)	63	58	48	41	37	35	27	25
		500 (236)	64	59	49	42	38	36	28	26
		600 (283)	66	61	50	44	39	37	31	29
3	10	125 (59)	49	46	41	36	32	33	<15	<15
		300 (142)	52	50	44	39	34	35	18	<15
		425 (201)	56	53	47	42	36	37	21	16
		675 (319)	63	61	53	47	40	41	31	26
		780 (368)	66	62	55	49	43	44	32	29
		925 (437)	67	64	56	50	44	45	34	30
		1175 (555)	71	68	59	53	45	46	39	35
4	12	500 (236)	61	60	56	53	45	42	31	25
		700 (330)	64	63	58	56	48	46	33	28
		900 (425)	67	66	60	59	50	50	37	32
		1000 (472)	69	67	61	61	52	52	38	33
		1100 (519)	70	68	62	62	53	53	39	34
		1300 (614)	72	71	64	66	56	57	42	38
		1500 (708)	75	74	66	69	58	61	46	41
5	14	800 (378)	58	54	47	38	35	36	22	18
		950 (448)	62	56	51	43	40	40	25	23
		1100 (519)	67	60	57	49	48	47	32	30
		1200 (566)	68	61	58	50	49	48	33	31
		1300 (614)	69	62	59	51	50	49	34	32
		1500 (708)	71	66	63	53	52	51	38	35
		1700 (802)	72	68	65	54	53	52	41	36
		1800 (850)	75	69	66	55	53	53	42	40
6	16	800 (378)	62	58	52	46	42	40	27	23
		1000 (472)	66	63	60	55	47	45	35	29
		1250 (590)	72	69	64	59	52	50	40	36
		1400 (661)	73	71	65	61	54	53	42	38
		1650 (779)	74	72	66	62	56	55	44	39
		1800 (850)	76	73	67	63	57	56	45	41
		2160 (1020)	78	75	68	65	59	58	47	44
7	18x16	1875 (885)	72	67	61	56	47	46	38	36
		2100 (991)	73	68	63	57	49	48	39	38
		2400 (1133)	75	71	67	62	54	53	43	40

**NOTE 1:** Performance data contained within a bold border outline are AHRI certified data.

**NOTE 2:** Performance data not contained within a bold border outline are application ratings. Application ratings are outside the scope of the Certification Program.

**NOTE 3:** Performance data is obtained from laboratory testing in accordance with AHRI 880-2011 and ANSI/ASHRAE 130-2008.

**NOTE 4:** NC values are calculated using attenuation credits outlined in Appendix E of AHRI 885-2008.

**NOTE 5:** Discharge Sound power levels shown with End Reflection Corrections Included in dB (ref: 10<sup>-12</sup> watts).

**NOTE 6:** Minimum Ps is the static pressure drop across the air terminal unit while the inlet damper is in the wide-open position at a given airflow rate.

**Table 63: MQFVI-500 Radiated Sound Power Level at Inlet Ps = 0.25, 0.50, and 0.75 in.w.g. (Cooling)**

Case Size	Inlet Size (in)	CFM (L/s)	Min Ps in.w.g. (Pa)	Inlet Ps = 0.25 in.w.g. (62 Pa)							Inlet Ps = 0.50 in.w.g. (125 Pa)							Inlet Ps = 0.75 in.w.g. (187 Pa)												
				Octave Band Sound Power, Lw, dB							NC	NC w/ SA	Octave Band Sound Power, Lw, dB							NC	NC w/ SA	Octave Band Sound Power, Lw, dB							NC	NC w/ SA
				2	3	4	5	6	7	2			3	4	5	6	7	2	3			4	5	6	7					
1	6	100 (47)	0.080 (20.0)	45	34	28	23	19	20	<15	<15	46	35	29	24	20	21	<15	<15	46	36	30	25	21	21	<15	<15			
		200 (94)	0.100 (24.9)	46	37	31	26	21	22	<15	<15	47	38	32	27	23	23	<15	<15	48	39	32	28	23	24	<15	<15			
		250 (118)	0.110 (27.5)	48	39	33	28	22	24	<15	<15	48	40	35	29	25	27	<15	<15	49	41	38	30	28	30	<15	<15			
		300 (142)	0.127 (31.6)	48	40	33	29	24	24	<15	<15	49	41	36	30	26	27	<15	<15	50	42	38	32	28	31	<15	<15			
		400 (189)	0.160 (39.7)	50	44	36	31	26	27	<15	<15	51	44	38	32	28	29	<15	<15	52	45	41	34	30	31	<15	<15			
		450 (212)	0.176 (43.8)	51	45	38	32	27	28	<15	<15	52	46	40	33	29	30	<15	<15	53	46	42	35	31	31	<15	<15			
		500 (236)	0.192 (47.9)	53	47	39	33	28	29	<15	<15	53	47	41	35	30	30	<15	<15	53	47	42	36	32	32	15	<15			
600 (283)	0.241 (60.1)	55	49	43	38	31	31	17	<15	56	50	44	40	34	33	18	16	57	50	45	41	34	33	19	17					
2	8	200 (94)	0.084 (20.9)	46	35	27	21	17	18	<15	<15	47	36	27	22	18	19	<15	<15	49	37	29	23	19	21	<15	<15			
		300 (142)	0.094 (23.5)	48	39	31	25	20	22	<15	<15	49	40	32	26	20	23	<15	<15	50	42	33	28	22	24	<15	<15			
		400 (189)	0.105 (26.2)	50	41	34	28	22	23	<15	<15	51	42	34	28	23	25	<15	<15	52	43	35	30	24	27	<15	<15			
		500 (236)	0.116 (28.8)	51	43	36	30	23	25	<15	<15	53	45	37	32	26	29	<15	<15	54	47	39	33	28	32	<15	<15			
		650 (307)	0.138 (34.4)	52	47	41	34	26	27	<15	<15	54	48	41	35	27	30	15	<15	56	49	41	35	29	33	17	16			
700 (330)	0.146 (36.3)	53	48	42	35	27	28	15	<15	55	49	42	36	28	31	16	16	57	50	42	36	30	33	18	18					
3	10	300 (142)	0.088 (21.9)	49	41	38	35	27	20	<15	<15	50	40	38	35	27	20	<15	<15	52	41	39	36	28	22	<15	<15			
		500 (236)	0.103 (26.5)	51	43	40	37	29	21	<15	<15	53	43	40	37	30	22	<15	<15	54	44	42	39	32	24	15	<15			
		775 (366)	0.125 (31.1)	53	45	41	38	30	22	<15	<15	56	46	42	39	32	27	17	16	59	49	44	41	35	31	21	20			
		925 (437)	0.136 (33.9)	54	46	42	39	31	23	15	<15	57	48	43	41	33	27	18	17	60	50	46	42	36	32	22	21			
1100 (519)	0.158 (39.3)	55	48	45	42	31	23	19	<15	57	50	45	42	34	29	19	17	62	52	47	43	37	32	25	23					
4	12	450 (212)	0.076 (18.9)	48	40	36	33	25	20	<15	<15	49	40	37	34	27	23	<15	<15	51	42	39	36	30	29	<15	<15			
		650 (307)	0.084 (20.9)	51	43	38	37	28	25	<15	<15	52	44	39	38	29	27	<15	<15	54	46	42	39	35	32	15	<15			
		900 (425)	0.094 (23.4)	54	47	41	40	29	27	<15	<15	56	49	43	42	32	31	17	16	61	53	45	42	41	36	23	22			
		1100 (519)	0.100 (25.0)	56	53	47	43	35	27	21	16	59	54	47	44	37	32	22	20	63	54	47	44	42	37	26	25			
		1300 (614)	0.107 (26.6)	57	55	49	45	36	28	24	19	60	56	49	45	38	32	25	21	64	55	49	45	43	38	27	26			
		1500 (708)	0.118 (29.4)	64	56	50	45	39	35	27	26	64	56	50	46	43	39	27	26	65	56	51	47	44	40	29	27			
5	14	550 (260)	0.072 (18.0)	41	41	32	28	16	20	<15	<15	44	43	34	30	22	22	<15	<15	46	45	36	32	25	21	<15	<15			
		800 (378)	0.081 (20.1)	44	43	34	30	19	23	<15	<15	47	45	36	31	25	24	<15	<15	49	47	38	34	28	23	<15	<15			
		1000 (472)	0.090 (22.5)	48	45	36	32	22	25	<15	<15	50	47	39	34	27	27	<15	<15	52	49	41	38	31	27	16	<15			
		1500 (708)	0.106 (26.5)	55	49	40	35	28	29	16	<15	58	51	42	38	32	30	20	18	59	54	45	41	36	31	22	20			
2000 (944)	0.134 (33.3)	58	50	42	37	30	31	20	18	59	53	44	40	34	32	21	20	61	55	47	43	38	33	24	22					
6	16	750 (354)	0.083 (20.6)	49	44	35	30	26	24	<15	<15	51	46	37	33	29	28	<15	<15	53	48	39	36	32	31	15	<15			
		950 (448)	0.088 (21.8)	52	45	37	33	29	26	<15	<15	54	47	39	35	32	30	<15	<15	56	50	42	38	35	32	18	16			
		1525 (720)	0.104 (25.9)	57	47	40	36	32	28	18	17	59	49	42	38	35	32	21	20	61	53	47	42	38	33	23	22			
		1800 (850)	0.115 (28.7)	60	48	44	42	37	30	22	21	62	54	48	47	41	36	25	23	64	59	53	49	45	41	28	26			
2400 (1133)	0.138 (34.3)	65	58	52	48	43	37	29	27	67	60	54	49	45	40	31	30	68	62	56	51	47	42	32	31					
7	18x16	975 (460)	0.178 (44.4)	54	40	38	36	34	31	<15	<15	56	43	39	37	35	33	17	16	58	45	42	39	37	35	20	18			
		1200 (566)	0.021 (5.2)	56	43	41	39	37	32	17	16	58	46	44	42	39	35	20	18	60	48	46	44	41	37	22	21			
		1600 (755)	0.028 (6.9)	59	47	45	44	40	34	21	20	60	49	48	47	42	37	22	21	61	52	50	49	45	41	24	22			
		2000 (944)	0.036 (9.0)	62	52	50	51	43	37	25	23	64	56	53	53	46	41	27	26	66	60	57	55	50	46	32	29			
		2500 (1180)	0.056 (14.0)	66	59	56	54	48	42	31	29	67	60	57	55	49	44	32	30	69	62	59	56	51	47	34	32			

**NOTE 1:** Performance data contained within a bold border outline are AHRI certified data.

**NOTE 2:** Performance data not contained within a bold border outline are application ratings. Application ratings are outside the scope of the Certification Program.

**NOTE 3:** Performance data is obtained from laboratory testing in accordance with AHRI 880-2011 and ANSI/ASHRAE 130-2008.

**NOTE 4:** NC values are calculated using attenuation credits outlined in Appendix E of AHRI 885-2008.

**NOTE 5:** Discharge Sound power levels shown with End Reflection Corrections Included in dB (ref: 10<sup>-12</sup> watts).

**NOTE 6:** Minimum Ps is the static pressure drop across the air terminal unit while the inlet damper is in the wide-open position at a given airflow rate.

**Table 64: MQFVI-500 Radiated Sound Power Level at Inlet Ps = 1.25, 1.50, and 1.75 in.w.g. (Cooling)**

Case Size	Inlet Size (in)	CFM (L/s)	Min Ps in.w.g. (Pa)	Inlet Ps = 0.25 in.w.g. (62 Pa)							Inlet Ps = 0.50 in.w.g. (125 Pa)							Inlet Ps = 0.75 in.w.g. (187 Pa)												
				Octave Band Sound Power, Lw, dB							NC	NC w/ SA	Octave Band Sound Power, Lw, dB							NC	NC w/ SA	Octave Band Sound Power, Lw, dB							NC	NC w/ SA
				2	3	4	5	6	7	2			3	4	5	6	7	2	3			4	5	6	7					
1	6	100 (47)	0.080 (20.0)	50	39	33	30	25	22	<15	<15	50	40	33	30	26	23	<15	<15	51	41	33	30	26	24	<15	<15			
		200 (94)	0.100 (24.9)	52	43	34	31	28	25	<15	<15	53	44	34	31	28	26	<15	<15	53	44	35	31	29	27	<15	<15			
		250 (118)	0.110 (27.5)	54	47	39	35	31	30	<15	<15	55	48	40	36	32	33	16	<15	55	49	41	37	32	35	16	<15			
		300 (142)	0.127 (31.6)	54	48	39	36	32	30	15	<15	55	49	41	37	32	33	16	<15	55	49	42	37	33	35	16	<15			
		400 (189)	0.160 (39.7)	55	50	42	37	34	32	18	<15	56	50	43	38	34	34	18	<15	56	50	43	39	34	36	18	16			
		450 (212)	0.176 (43.8)	56	51	46	41	35	33	20	16	56	51	45	41	35	34	19	17	57	52	45	41	35	36	20	17			
2	8	200 (94)	0.084 (20.9)	50	39	30	25	22	18	<15	<15	51	39	31	26	23	19	<15	<15	51	39	31	26	23	20	<15	<15			
		300 (142)	0.094 (23.5)	51	44	35	30	24	20	<15	<15	52	44	35	31	25	21	<15	<15	52	43	35	31	26	21	<15	<15			
		400 (189)	0.105 (26.2)	53	45	37	32	27	22	<15	<15	54	45	37	33	28	23	<15	<15	54	45	37	33	29	24	<15	<15			
		500 (236)	0.116 (28.8)	55	49	40	35	30	27	16	<15	56	49	41	36	31	29	17	<15	56	49	41	37	32	30	17	16			
		650 (307)	0.138 (34.4)	57	51	42	37	32	28	19	17	58	51	43	38	33	29	20	18	59	51	43	39	34	30	21	20			
		700 (330)	0.146 (36.3)	58	52	43	38	33	28	20	20	59	52	43	39	34	29	21	21	60	52	44	40	35	30	22	22			
3	10	300 (142)	0.088 (21.9)	54	42	40	39	31	23	<15	<15	55	43	41	40	32	25	16	<15	56	44	42	40	33	26	17	16			
		500 (236)	0.103 (25.7)	56	45	43	41	34	25	17	16	57	46	44	42	35	27	18	17	57	47	44	43	36	28	18	17			
		775 (366)	0.125 (31.1)	60	50	45	43	37	32	22	21	61	52	47	45	39	34	23	22	61	53	48	46	40	35	23	22			
		925 (437)	0.136 (33.9)	62	51	46	45	38	33	25	23	62	53	48	46	39	34	25	23	62	55	50	47	40	35	25	23			
		1100 (519)	0.158 (39.3)	63	52	47	46	40	34	26	25	63	54	50	47	41	35	26	25	63	56	52	48	41	36	26	25			
4	12	450 (212)	0.076 (18.9)	53	45	40	38	35	32	<15	<15	55	47	42	39	37	34	16	<15	56	49	43	40	39	35	17	16			
		650 (307)	0.084 (20.9)	57	50	44	42	39	36	18	17	59	53	46	44	41	38	21	20	60	55	48	45	42	40	24	21			
		900 (425)	0.094 (23.4)	63	56	49	45	43	41	26	25	65	58	51	47	45	43	29	27	66	59	53	49	47	45	30	29			
		1100 (519)	0.100 (25.0)	65	57	50	47	44	42	29	27	67	59	52	49	46	44	31	30	68	61	54	50	48	46	32	31			
		1300 (614)	0.107 (26.6)	66	58	52	48	45	42	30	29	68	60	54	50	47	44	32	30	69	62	55	51	49	46	34	32			
		1500 (708)	0.118 (29.4)	67	59	53	49	46	43	31	30	69	61	55	51	48	45	34	32	71	63	56	52	49	47	36	35			
5	14	550 (260)	0.072 (18.0)	49	47	38	34	28	21	<15	<15	51	48	41	36	30	22	15	<15	52	48	43	37	32	23	17	<15			
		800 (378)	0.081 (20.1)	52	49	41	36	32	24	16	<15	53	52	43	38	33	25	20	15	54	54	45	40	34	26	22	18			
		1000 (472)	0.090 (22.5)	55	54	45	42	35	28	22	18	57	56	47	44	36	29	25	20	59	57	49	45	37	30	26	21			
		1500 (708)	0.106 (26.5)	62	58	49	45	40	33	27	23	64	59	51	47	42	35	28	25	65	60	52	48	43	37	29	27			
6	16	2000 (944)	0.134 (33.3)	64	59	50	46	41	34	28	26	66	61	52	48	43	36	31	29	68	62	54	50	45	38	32	31			
		750 (354)	0.083 (20.6)	56	50	43	39	35	33	18	16	57	51	45	41	36	34	19	17	58	52	46	42	37	35	20	18			
		950 (448)	0.088 (21.8)	58	52	50	42	37	39	24	18	59	54	51	45	41	41	25	20	60	56	52	48	45	43	26	21			
		1525 (720)	0.104 (25.9)	64	56	53	46	44	43	27	26	65	59	55	48	47	46	30	27	66	62	57	50	49	48	32	29			
7	18x16	1800 (850)	0.115 (28.7)	67	62	57	53	49	46	32	30	68	64	59	56	52	49	34	30	68	65	60	58	55	51	35	31			
		2400 (1133)	0.138 (34.3)	70	64	59	54	50	47	35	34	71	66	61	57	53	49	37	35	72	67	62	59	55	51	38	36			
		975 (460)	0.178 (44.4)	60	48	45	42	40	39	22	21	61	50	47	44	42	40	23	22	61	52	48	46	43	41	23	22			
		1200 (566)	0.021 (5.2)	62	50	48	47	44	41	25	23	63	53	50	48	46	42	26	25	63	56	51	49	48	43	26	25			
		1600 (755)	0.028 (6.9)	63	57	53	52	48	45	27	25	64	59	55	54	50	47	30	26	65	61	56	55	52	48	31	27			
2000 (944)	0.036 (9.0)	68	63	60	58	53	50	35	31	69	65	62	61	56	53	37	32	70	66	64	63	59	55	39	34					
2500 (1180)	0.056 (14.0)	70	65	62	59	54	51	37	34	72	67	64	62	57	54	39	35	73	68	66	64	59	56	42	38					

- NOTE 1:** Performance data contained within a bold border outline are AHRI certified data.
- NOTE 2:** Performance data not contained within a bold border outline are application ratings. Application ratings are outside the scope of the Certification Program.
- NOTE 3:** Performance data is obtained from laboratory testing in accordance with AHRI 880-2011 and ANSI/ASHRAE 130-2008.
- NOTE 4:** NC values are calculated using attenuation credits outlined in Appendix E of AHRI 885-2008.
- NOTE 5:** Discharge Sound power levels shown with End Reflection Corrections Included in dB (ref: 10<sup>-12</sup> watts).
- NOTE 6:** Minimum Ps is the static pressure drop across the air terminal unit while the inlet damper is in the wide-open position at a given airflow rate.



**Table 65: MQFVI-500 Discharge Sound Power Level at Fan Only (Heating)**

Case Size	Inlet Size (in)	CFM (L/s)	Fan Only							
			Octave Band Sound Power, Lw, dB							NC
			2	3	4	5	6	7		
1	6	150 (71)	42	40	37	36	33	29	<15	
		200 (94)	50	47	44	43	39	35	<15	
		250 (118)	58	55	51	50	45	40	<15	
		270 (127)	59	56	52	50	46	41	<15	
		300 (142)	60	57	53	51	47	42	<15	
		400 (189)	65	61	57	55	51	45	19	
		450 (212)	67	63	59	57	53	47	21	
2	8	250 (118)	55	49	47	47	42	36	<15	
		300 (142)	56	50	48	48	43	37	<15	
		350 (165)	57	52	50	50	44	38	<15	
		400 (189)	57	53	52	52	46	39	<15	
		440 (208)	58	54	52	53	47	40	<15	
		500 (236)	59	55	53	54	48	42	<15	
		600 (283)	65	60	55	56	50	49	18	
3	10	125 (59)	43	41	36	28	36	27	<15	
		300 (142)	48	47	42	35	41	35	<15	
		425 (201)	54	51	45	39	46	36	<15	
		675 (319)	63	60	57	55	50	46	18	
		780 (368)	65	61	58	57	54	50	18	
		925 (437)	70	63	60	61	58	57	21	
		1175 (555)	72	67	62	62	60	59	25	
4	12	500 (236)	60	58	54	52	50	46	15	
		700 (330)	64	62	56	55	54	50	20	
		900 (425)	66	65	58	57	56	53	22	
		1000 (472)	68	66	59	60	58	55	24	
		1100 (519)	69	67	59	63	59	56	25	
		1300 (614)	71	70	61	62	62	59	28	
		1500 (708)	73	72	63	64	63	61	31	
5	14	800 (378)	60	56	50	46	43	40	<15	
		950 (448)	63	58	58	55	52	49	<15	
		1100 (519)	59	61	58	56	53	52	18	
		1200 (566)	60	62	59	57	54	53	19	
		1300 (614)	61	62	60	58	55	54	19	
		1500 (708)	73	71	63	62	60	60	29	
		1700 (802)	74	73	64	64	61	63	32	
6	16	800 (378)	58	55	55	52	48	44	<15	
		1000 (472)	61	58	57	56	51	48	<15	
		1250 (590)	64	61	60	55	54	52	18	
		1400 (661)	66	63	62	60	56	54	20	
		1650 (779)	70	67	65	61	60	60	25	
		1800 (850)	73	70	67	69	63	64	28	
		2160 (1020)	75	72	68	67	66	65	31	
7	18×16	1875 (885)	71	68	70	65	64	67	31	
		2100 (991)	74	71	72	68	66	69	32	
		2400 (1133)	77	74	74	71	69	71	34	

**NOTE 1:** Performance data contained within a bold border outline are AHRI certified data.

**NOTE 2:** Performance data not contained within a bold border outline are application ratings. Application ratings are outside the scope of the Certification Program.

**NOTE 3:** Performance data is obtained from laboratory testing in accordance with AHRI 880-2011 and ANSI/ASHRAE 130-2008.

**NOTE 4:** NC values are calculated using attenuation credits outlined in Appendix E of AHRI 885-2008.

**NOTE 5:** Discharge Sound power levels shown with End Reflection Corrections Included in dB (ref: 10<sup>-12</sup> watts).

**NOTE 6:** Minimum Ps is the static pressure drop across the air terminal unit while the inlet damper is in the wide-open position at a given airflow rate.

**Table 66: MQFVI-500 Discharge Sound Power Level at Inlet Ps = 0.25, 0.50, and 0.75 in.w.g. (Cooling)**

Case Size	Inlet Size (in)	CFM (L/s)	Min Ps in.w.g. (Pa)	Inlet Ps = 0.25 in.w.g. (62 Pa)							Inlet Ps = 0.50 in.w.g. (125 Pa)							Inlet Ps = 0.75 in.w.g. (187 Pa)								
				Octave Band Sound Power, Lw, dB							NC	Octave Band Sound Power, Lw, dB							NC	Octave Band Sound Power, Lw, dB						
				2	3	4	5	6	7	NC		2	3	4	5	6	7	NC		2	3	4	5	6	7	NC
1	6	100 (47)	0.080 (20.0)	52	38	33	28	27	26	<15	53	39	33	29	28	27	<15	53	40	33	30	29	26	<15		
		200 (94)	0.100 (24.9)	54	41	36	31	30	28	<15	53	42	37	32	31	29	<15	54	43	36	33	31	29	<15		
		250 (118)	0.110 (27.5)	55	43	38	33	31	30	<15	55	45	40	34	34	34	<15	56	45	42	35	38	37	<15		
		300 (142)	0.127 (31.6)	55	44	39	34	33	31	<15	56	46	42	36	37	34	<15	57	46	43	37	39	38	<15		
		400 (189)	0.160 (39.7)	57	48	42	37	37	34	<15	58	49	44	38	39	37	<15	59	49	46	40	41	38	<15		
		450 (212)	0.176 (43.8)	58	49	44	38	38	36	<15	59	51	46	39	40	38	<15	60	50	47	41	42	38	<15		
		500 (236)	0.192 (47.9)	60	51	46	39	40	37	<15	60	52	47	41	41	38	<15	60	51	47	42	43	39	<15		
2	8	600 (283)	0.241 (60.1)	63	53	50	45	44	40	<15	63	55	50	45	45	41	<15	64	54	50	46	45	40	16		
		200 (94)	0.084 (20.9)	56	42	34	32	29	25	<15	56	43	34	32	29	25	<15	58	43	36	34	31	26	<15		
		300 (142)	0.094 (23.5)	58	46	39	38	34	30	<15	59	47	40	38	34	30	<15	60	48	41	42	34	29	<15		
		400 (189)	0.105 (26.2)	60	49	43	42	37	33	<15	61	50	43	41	38	32	<15	62	50	44	45	38	33	<15		
		500 (236)	0.116 (28.8)	61	51	45	45	40	35	<15	63	53	46	46	42	39	<15	64	54	48	48	44	40	16		
		650 (307)	0.138 (34.4)	62	55	51	51	45	38	<15	64	56	51	51	45	40	16	66	56	51	52	46	41	18		
		700 (330)	0.146 (36.3)	62	55	51	51	45	38	<15	64	56	51	51	45	40	16	66	56	51	52	46	41	18		
3	10	300 (142)	0.088 (21.9)	59	48	45	44	34	29	<15	59	51	45	44	37	33	<15	59	52	45	46	39	32	<15		
		500 (236)	0.103 (25.7)	61	54	47	47	38	30	<15	61	54	48	47	41	35	<15	61	55	48	50	44	35	<15		
		775 (366)	0.125 (31.1)	66	56	48	48	39	33	16	66	56	50	49	43	42	16	66	60	50	52	48	43	16		
		925 (437)	0.136 (33.9)	67	58	50	50	40	34	17	67	58	51	51	44	42	17	67	61	51	53	49	44	18		
		1100 (519)	0.158 (39.3)	67	58	50	50	40	34	17	67	58	51	51	44	42	17	67	61	51	53	49	44	18		
4	12	450 (212)	0.076 (18.9)	59	52	43	41	37	32	<15	62	55	47	44	40	35	<15	65	58	51	45	39	35	17		
		650 (307)	0.084 (20.9)	62	54	46	44	40	36	<15	64	57	49	46	43	38	16	67	60	53	48	42	39	20		
		900 (425)	0.094 (23.4)	65	56	50	47	43	38	<15	67	59	52	49	45	42	17	69	61	55	51	45	42	20		
		1100 (519)	0.100 (25.0)	67	58	52	50	46	44	17	69	60	54	52	48	44	20	70	62	56	52	48	45	21		
		1300 (614)	0.107 (26.6)	69	60	54	55	49	47	20	70	62	56	55	50	47	21	72	64	58	56	50	48	23		
		1500 (708)	0.118 (29.4)	72	61	57	57	53	50	23	73	63	58	57	53	51	25	73	65	60	57	53	51	25		
5	14	550 (260)	0.072 (18.0)	49	47	41	38	27	25	<15	53	49	43	41	33	31	<15	54	51	44	43	36	33	<15		
		800 (378)	0.081 (20.1)	52	49	43	40	31	29	<15	56	51	45	42	36	33	<15	57	53	46	45	40	35	<15		
		1000 (472)	0.090 (22.5)	56	51	45	42	34	31	<15	59	53	48	45	39	36	<15	60	55	49	49	43	39	<15		
		1500 (708)	0.106 (26.5)	63	55	49	45	41	35	<15	66	57	51	49	44	39	16	66	60	53	53	48	44	16		
		2000 (944)	0.134 (33.3)	65	56	51	47	43	37	<15	67	59	53	52	46	42	17	68	61	55	55	51	46	18		
		750 (354)	0.083 (20.6)	61	52	47	42	32	30	<15	64	54	49	43	38	32	<15	65	56	50	43	39	33	<15		
6	16	950 (448)	0.088 (21.8)	63	54	48	43	35	32	<15	66	56	50	45	40	35	16	67	57	52	45	41	39	17		
		1525 (720)	0.104 (25.9)	67	61	53	47	41	35	18	68	61	54	49	45	41	18	70	61	56	49	46	45	21		
		1800 (850)	0.115 (28.7)	70	62	54	49	43	38	21	71	63	56	50	47	45	22	72	63	58	51	49	47	23		
		2400 (1133)	0.138 (34.3)	75	67	59	52	50	48	27	76	67	60	54	52	51	29	76	68	61	56	55	54	29		
		975 (460)	0.178 (44.4)	61	56	48	42	34	31	<15	62	57	48	43	36	32	<15	62	57	49	44	36	33	<15		
7	18x16	1200 (566)	0.021 (5.2)	66	63	54	52	47	46	20	67	63	55	53	48	47	20	67	63	56	54	49	48	20		
		1600 (755)	0.028 (6.9)	69	64	56	55	51	50	21	70	65	57	56	53	51	22	71	66	58	57	54	51	24		
		2000 (944)	0.036 (9.0)	73	67	58	57	54	53	25	74	68	59	58	56	54	26	75	69	59	59	57	55	27		
		2500 (1180)	0.056 (14.0)	77	70	61	59	59	58	30	78	71	61	60	59	59	31	79	73	62	61	60	59	32		

- NOTE 1:** Performance data contained within a bold border outline are AHRI certified data.
- NOTE 2:** Performance data not contained within a bold border outline are application ratings. Application ratings are outside the scope of the Certification Program.
- NOTE 3:** Performance data is obtained from laboratory testing in accordance with AHRI 880-2011 and ANSI/ASHRAE 130-2008.
- NOTE 4:** NC values are calculated using attenuation credits outlined in Appendix E of AHRI 885-2008.
- NOTE 5:** Discharge Sound power levels shown with End Reflection Corrections Included in dB (ref: 10<sup>-12</sup> watts).
- NOTE 6:** Minimum Ps is the static pressure drop across the air terminal unit while the inlet damper is in the wide-open position at a given airflow rate.

**Table 67: MQFVI-500 Discharge Sound Power Level at Inlet Ps = 1.25, 1.50, and 1.75 in.w.g. (Cooling)**

Case Size	Inlet Size (in)	CFM (L/s)	Min Ps in.w.g. (Pa)	Inlet Ps = 0.25 in.w.g. (62 Pa)							Inlet Ps = 0.50 in.w.g. (125 Pa)							Inlet Ps = 0.75 in.w.g. (187 Pa)								
				Octave Band Sound Power, Lw, dB							NC	Octave Band Sound Power, Lw, dB							NC	Octave Band Sound Power, Lw, dB						
				2	3	4	5	6	7	8		2	3	4	5	6	7	8		2	3	4	5	6	7	8
1	6	100 (47)	0.080 (20.0)	56	42	40	37	33	30	<15	57	43	40	37	34	31	<15	57	44	40	38	34	32	<15		
		200 (94)	0.100 (24.9)	59	46	41	39	36	33	<15	60	47	42	39	38	34	<15	60	48	43	40	39	35	<15		
		250 (118)	0.110 (27.5)	61	51	46	43	41	41	16	62	52	48	45	42	43	17	62	53	51	47	43	46	17		
		300 (142)	0.127 (31.6)	61	52	47	45	42	41	<15	62	53	49	47	43	43	17	62	53	52	49	44	46	<15		
		400 (189)	0.160 (39.7)	62	54	50	46	45	43	<15	62	54	51	48	45	45	17	63	54	53	50	45	47	<15		
		450 (212)	0.176 (43.8)	63	55	54	51	46	44	<15	63	55	55	51	46	46	18	64	56	55	52	46	47	16		
		500 (236)	0.192 (47.9)	64	56	55	53	47	44	16	64	56	56	53	47	46	20	65	57	56	53	47	47	17		
600 (283)	0.241 (60.1)	65	57	56	53	48	45	17	65	57	57	54	49	46	21	66	58	58	55	49	46	18				
2	8	200 (94)	0.084 (20.9)	58	45	37	35	33	28	<15	58	46	38	35	34	29	<15	59	47	38	36	34	31	<15		
		300 (142)	0.094 (23.5)	60	50	42	42	37	31	<15	60	50	43	42	38	32	<15	61	51	43	43	39	33	<15		
		400 (189)	0.105 (26.2)	62	52	45	45	40	34	<15	62	52	45	46	41	35	17	63	53	46	46	42	36	<15		
		500 (236)	0.116 (28.8)	64	56	48	49	46	43	16	64	57	49	50	47	44	20	65	58	50	52	48	46	17		
		650 (307)	0.138 (34.4)	66	58	51	52	48	44	18	67	59	52	53	49	45	20	68	60	53	54	50	46	15		
		700 (330)	0.146 (36.3)	66	58	51	52	48	44	18	67	59	52	53	49	45	20	68	60	53	54	50	46	15		
3	10	300 (142)	0.088 (21.9)	61	52	50	49	44	37	<15	62	52	50	49	45	38	17	63	52	49	49	45	39	<15		
		500 (236)	0.103 (25.7)	63	55	53	51	47	39	<15	64	55	52	52	48	41	20	64	55	51	52	48	42	16		
		775 (366)	0.125 (31.1)	67	60	55	53	51	48	17	68	61	55	54	52	49	21	68	61	55	55	53	50	18		
		925 (437)	0.136 (33.9)	69	61	56	55	52	49	20	69	62	57	56	53	50	22	69	63	57	56	53	50	20		
		1100 (519)	0.158 (39.3)	69	61	56	55	52	49	20	69	62	57	56	53	50	22	69	63	57	56	53	50	20		
4	12	450 (212)	0.076 (18.9)	66	59	53	47	41	37	18	67	60	54	48	43	40	23	67	60	54	49	45	42	20		
		650 (307)	0.084 (20.9)	68	61	55	49	44	40	21	69	62	56	51	45	43	22	70	62	56	52	46	45	23		
		900 (425)	0.094 (23.4)	70	62	57	52	47	43	21	71	63	57	53	48	45	25	71	63	58	54	50	47	22		
		1100 (519)	0.100 (25.0)	71	64	58	54	49	46	22	72	65	59	55	51	48	26	72	65	60	57	52	50	23		
		1300 (614)	0.107 (26.6)	73	66	59	57	51	49	25	74	67	60	58	53	51	29	75	67	62	60	55	54	27		
5	14	1500 (708)	0.118 (29.4)	75	68	61	58	53	51	27	76	68	62	61	55	53	29	77	69	64	63	56	55	30		
		550 (260)	0.072 (18.0)	57	53	46	45	40	37	<15	58	53	49	47	42	37	<15	59	53	51	49	44	37	<15		
		800 (378)	0.081 (20.1)	60	55	49	47	45	40	<15	61	57	51	50	46	40	<15	61	59	53	52	47	40	15		
		1000 (472)	0.090 (22.5)	62	60	53	54	48	44	16	64	61	55	56	49	45	19	65	62	57	57	50	45	19		
		1500 (708)	0.106 (26.5)	69	64	57	57	54	50	21	70	65	59	59	56	51	22	71	65	60	61	57	52	22		
2000 (944)	0.134 (33.3)	71	65	58	58	55	51	22	73	66	61	61	57	52	25	74	67	63	63	59	53	26				
6	16	750 (354)	0.083 (20.6)	66	57	51	45	41	40	16	67	58	52	51	42	41	20	67	59	53	57	43	42	17		
		950 (448)	0.088 (21.8)	68	59	54	47	43	42	18	69	60	55	49	44	43	22	69	60	56	50	45	44	20		
		1525 (720)	0.104 (25.9)	71	62	57	50	47	46	22	72	63	58	52	49	48	23	72	63	59	53	51	50	23		
		1800 (850)	0.115 (28.7)	73	65	59	53	52	51	25	74	66	61	55	53	52	26	74	67	63	57	53	52	26		
		2400 (1133)	0.138 (34.3)	78	69	62	58	57	56	31	79	70	64	59	58	57	32	80	71	66	60	58	57	34		
7	18x16	975 (460)	0.178 (44.4)	64	58	50	48	41	35	<15	64	58	50	48	41	35	16	64	58	50	48	41	35	<15		
		1200 (566)	0.021 (5.2)	68	64	57	56	51	49	21	68	64	57	56	51	49	22	68	64	57	56	51	49	21		
		1600 (755)	0.028 (6.9)	72	67	59	58	56	52	25	72	67	59	58	56	52	25	72	67	59	58	56	52	25		
		2000 (944)	0.036 (9.0)	77	72	61	60	58	57	31	77	72	61	60	58	57	31	77	72	61	60	58	57	31		
		2500 (1180)	0.056 (14.0)	80	75	63	61	60	59	34	80	75	63	61	60	59	34	80	75	63	61	60	59	34		

**NOTE 1:** Performance data contained within a bold border outline are AHRI certified data.

**NOTE 2:** Performance data not contained within a bold border outline are application ratings. Application ratings are outside the scope of the Certification Program.

**NOTE 3:** Performance data is obtained from laboratory testing in accordance with AHRI 880-2011 and ANSI/ASHRAE 130-2008.

**NOTE 4:** NC values are calculated using attenuation credits outlined in Appendix E of AHRI 885-2008.

**NOTE 5:** Discharge Sound power levels shown with End Reflection Corrections Included in dB (ref: 10<sup>-12</sup> watts).

**NOTE 6:** Minimum Ps is the static pressure drop across the air terminal unit while the inlet damper is in the wide-open position at a given airflow rate.

**Table 68: MQFVI-500 ECM Amperage Ratings**

Case Size	Motor HP	ECM Amperage Ratings		
		115V-1 Phase 60 Hz Rated Amps	208-240V-1 Phase 60 Hz Rated Amps	277V-1 Phase 60 Hz Rated Amps
1	1/3	4.7	3	2.4
2	1/3	4.7	3	2.4
3	1/2	6.6	4.2	3.4
4	1/2	6.6	4.2	3.4
5	1	12	7.5	6.2
6	1	12	7.5	6.2
7	1	12	7.5	6.2

**Table 69: MQFVI-500 ECM Damper Leakage**

Inlet Size (in)	Damper Leakage, CFM		
	1.5" ΔPs	3.0" ΔPs	6.0" ΔPs
6	3	4	7
8	2	4	7
10	4	5	7
12	4	5	7
14	4	6	8
16	4	6	8

**Table 70: MQFVI-500 Minimum Pressures**

Case Size	CFM	Min PS	Unit ΔPs (in.w.g.) [no coil]	Unit ΔPt (in.w.g.) [no coil]	Unit + 1R Coil, ΔPs (in.w.g.)	Unit + 1R Coil, ΔPt (in.w.g.)	Unit + 2R Coil, ΔPt (in.w.g.)
1	100	0.08	0.10	0.08	0.10	0.09	0.11
	200	0.10	0.16	0.11	0.17	0.12	0.18
	300	0.13	0.27	0.14	0.28	0.16	0.30
	400	0.16	0.42	0.18	0.44	0.21	0.47
	500	0.19	0.59	0.22	0.62	0.26	0.66
	600	0.24	0.82	0.28	0.86	0.34	0.92
2	300	0.09	0.14	0.10	0.15	0.12	0.17
	400	0.11	0.18	0.13	0.20	0.16	0.23
	500	0.12	0.24	0.15	0.27	0.19	0.31
	600	0.13	0.31	0.17	0.35	0.23	0.41
	700	0.14	0.38	0.20	0.44	0.27	0.51
	800	0.16	0.47	0.23	0.54	0.32	0.63
3	600	0.12	0.30	0.14	0.32	0.17	0.35
	800	0.13	0.45	0.17	0.49	0.22	0.54
	1000	0.15	0.35	0.21	0.41	0.27	0.47
	1200	0.17	0.45	0.25	0.53	0.34	0.62
	1400	0.19	0.58	0.29	0.68	0.41	0.80
	1600	0.24	0.75	0.37	0.88	—	—
4	600	0.08	0.15	0.10	0.17	0.13	0.20
	800	0.09	0.22	0.13	0.26	0.18	0.31
	1000	0.10	0.19	0.16	0.25	0.22	0.31
	1200	0.11	0.24	0.19	0.32	0.28	0.41
	1400	0.12	0.30	0.22	0.40	0.34	0.52
	1600	0.13	0.36	0.26	0.49	0.40	0.63
5	600	0.07	0.10	0.09	0.12	0.12	0.15
	800	0.08	0.14	0.12	0.18	0.17	0.23
	1000	0.09	0.18	0.15	0.24	0.21	0.30
	1200	0.10	0.16	0.18	0.24	0.27	0.33
	1400	0.10	0.19	0.20	0.29	0.32	0.41
	1600	0.11	0.22	0.24	0.35	0.38	0.49
6	1000	0.09	0.14	0.14	0.19	0.20	0.25
	1200	0.10	0.17	0.17	0.24	0.24	0.31
	1400	0.10	0.19	0.19	0.28	0.29	0.38
	1600	0.11	0.23	0.22	0.34	0.34	0.46
	1800	0.11	0.26	0.24	0.39	0.39	0.54
	2000	0.12	0.31	0.28	0.47	0.46	0.65
	2200	0.13	0.35	0.32	0.54	—	—
	2400	0.14	0.28	0.36	0.50	—	—
7	1000	0.01	0.04	0.03	0.06	0.06	0.09
	1400	0.02	0.08	0.06	0.12	0.11	0.17
	1800	0.03	0.12	0.09	0.18	0.16	0.25
	2200	0.05	0.19	0.14	0.28	0.24	0.38
	2600	0.06	0.25	0.17	0.36	0.31	0.50
	3000	0.08	0.34	0.23	0.49	0.40	0.66
	3400	0.10	0.43	0.28	0.61	0.49	0.82

**NOTE 1:** ΔPs = static pressure drop; ΔPt = total pressure drop.

**NOTE 2:** Calculations of ΔPs and ΔPt were performed using standard air with a density of 0.075 lb m/cu ft.

**NOTE 3:** Data based on testing standard Daikin Applied hot water coils per AHRI Standard 410.

**NOTE 4:** Unit ΔPs and Unit ΔPt are pressure drops across the air terminal unit while the inlet damper is in the wide-open position

**NOTE 5:** Data applies to air terminal units with hot water coil mounted on the discharge side.

**NOTE 6:** '—' is shown when the static pressure drop exceeds 0.50 in.w.g.

**Table 71: MQFVI-500 Hot Water Coils Mbh Selection Data – Imperial Units**

Case Size	Rows	Connection OD	GPM	Head Loss (ft-H <sub>2</sub> O)	MBH							
					CFM							
					200	250	300	350	400	450	500	550
1	One	0.875	1	0.14	10.4	11.6	12.7	13.5	14.3	15.0	15.6	16.2
			2	0.54	11.5	13.0	14.3	15.4	16.5	17.4	18.2	19.0
			4	2.06	12.1	13.8	15.3	16.6	17.8	18.9	20.0	20.9
			6	4.52	12.3	14.1	15.6	17.1	18.4	19.5	20.6	21.6
			Airsides Ps		0.01	0.01	0.01	0.02	0.02	0.03	0.03	0.04
1	Two	0.875	1	0.09	14.3	16.2	17.8	19.1	20.3	21.3	22.2	—
			2	0.34	16.2	18.7	20.9	22.9	24.6	26.2	27.6	—
			4	1.32	17.4	20.3	23.0	25.4	27.6	29.6	31.5	—
			6	2.94	17.8	21.0	23.8	26.4	28.8	31.0	33.0	—
			Airsides Ps		0.02	0.02	0.03	0.04	0.05	0.06	0.07	—
					CFM							
					300	350	400	450	500	600	650	700
2	One	0.875	1	0.14	12.7	13.5	14.3	15.0	15.6	16.7	17.2	17.6
			2	0.54	14.3	15.4	16.5	17.4	18.2	19.7	20.4	21.1
			4	2.06	15.3	16.6	17.8	18.9	20.0	21.8	22.6	23.4
			6	4.52	15.7	17.1	18.4	19.5	20.6	22.6	23.5	24.3
			Airsides Ps		0.01	0.02	0.02	0.03	0.03	0.04	0.05	0.06
2	Two	0.875	1	0.09	17.8	19.1	20.3	21.3	22.2	23.7	24.4	—
			2	0.34	20.9	22.9	24.6	26.2	27.6	30.1	31.2	—
			4	1.32	23.0	25.4	27.6	29.6	31.5	34.8	36.3	—
			6	2.94	23.8	26.4	28.8	31.0	33.0	36.8	38.5	—
			Airsides Ps		0.03	0.04	0.05	0.06	0.07	0.10	0.11	—
					CFM							
					400	500	600	700	800	900	1000	1200
3	One	0.625	1	0.20	16.8	18.4	19.8	20.9	21.9	22.7	23.5	24.8
			2	0.76	19.3	21.5	23.4	25.1	26.6	27.9	29.1	31.1
			4	2.88	20.9	23.5	25.9	27.9	29.8	31.4	33.0	35.7
			6	6.30	21.5	24.3	26.8	29.0	31.1	32.9	34.6	37.5
			Airsides Ps		0.01	0.02	0.02	0.03	0.04	0.05	0.06	0.08
3	Two	0.875	1	0.10	22.9	25.3	27.1	28.7	30.0	31.1	32.1	—
			2	0.39	27.7	31.3	34.4	37.1	39.4	41.4	43.3	—
			4	1.51	30.9	35.6	39.7	43.3	46.6	49.6	52.3	—
			6	3.36	32.1	37.2	41.8	45.9	49.7	53.1	56.2	—
			Airsides Ps		0.03	0.04	0.05	0.07	0.09	0.10	0.12	—
					CFM							
					800	900	1000	1100	1200	1300	1400	1600
4	One	0.625	1	0.20	21.9	22.7	23.5	24.2	24.8	25.3	25.9	26.7
			2	0.76	26.6	27.9	29.1	30.1	31.1	32.0	32.9	34.4
			4	2.88	29.8	31.4	33.0	34.4	35.7	36.9	38.0	40.1
			6	6.31	31.1	32.9	34.6	36.1	37.5	38.9	40.2	42.5
			Airsides Ps		0.04	0.05	0.06	0.07	0.08	0.09	0.1	0.13
4	Two	0.875	1	0.10	30.0	31.1	32.1	32.9	33.6	34.3	34.9	—
			2	0.39	39.4	41.4	43.3	44.9	46.4	47.7	49.0	—
			4	1.52	46.6	49.6	52.3	54.8	57.1	59.2	61.2	—
			6	3.36	49.7	53.1	56.2	59.1	61.8	64.3	66.7	—
			Airsides Ps		0.09	0.10	0.12	0.15	0.17	0.19	0.22	—
					CFM							
					1000	1100	1200	1300	1400	1500	1600	1700
5	One	0.625	1	0.20	23.5	24.2	24.8	25.3	25.9	26.3	26.7	27.1
			2	0.76	29.1	30.1	31.1	32.0	32.9	33.6	34.4	35.0
			4	2.89	33.0	34.4	35.7	36.9	38.0	39.1	40.1	41.0
			6	6.32	34.6	36.1	37.5	38.9	40.2	41.4	42.5	43.6
			Airsides Ps		0.06	0.07	0.08	0.09	0.1	0.11	0.13	0.14
5	Two	0.875	1	0.10	32.1	32.9	33.6	34.3	34.9	35.4	35.9	—
			2	0.39	43.3	44.9	46.4	47.7	49.0	50.1	51.2	—
			4	1.52	52.3	54.7	57.1	59.2	61.2	63.0	64.7	—
			6	3.36	56.2	59.1	61.8	64.3	66.7	68.9	71.0	—
			Airsides Ps		0.12	0.15	0.17	0.19	0.22	0.24	0.27	—

Case Size	Rows	Connection OD	GPM	Head Loss (ft-H <sub>2</sub> O)	MBH							
					CFM							
					1000	1100	1200	1300	1400	1600	1800	2000
6	One	0.625	1	0.21	24.5	25.2	25.9	26.4	27.0	27.9	28.7	29.4
			2	0.81	30.4	31.5	32.5	33.5	34.4	36.0	37.4	38.7
			4	3.07	34.5	36.0	37.4	38.7	39.9	42.1	44.0	45.8
			6	6.72	36.2	37.8	39.3	40.8	42.1	44.6	46.8	48.9
			Airside Ps		0.05	0.06	0.07	0.07	0.09	0.11	0.13	0.16
6	Two	0.875	1	0.10	33.1	34.0	34.8	35.4	36.1	37.1	38.0	—
			2	0.40	44.8	46.5	48.1	49.5	50.8	53.1	55.1	—
			4	1.57	54.1	56.7	59.2	61.4	63.5	67.3	70.7	—
			6	3.47	58.2	61.3	64.1	66.8	69.3	73.9	78.0	—
			Airside Ps		0.11	0.12	0.14	0.16	0.19	0.23	0.28	—
					CFM							
					2000	2100	2200	2300	2400	2600	2800	3000
7	One	0.875	2	0.34	43.8	44.5	45.1	45.7	46.2	47.2	48.1	49.0
			4	1.32	54.0	55.0	55.9	56.8	57.7	59.3	60.9	62.3
			6	2.94	58.6	59.7	60.9	61.9	63.0	65.0	66.8	68.5
			8	5.19	61.2	62.5	63.7	64.9	66.0	68.2	70.3	72.2
			Airside Ps		0.07	0.08	0.09	0.09	0.1	0.11	0.13	0.15
7	Two	0.875	2	0.26	63.3	64.2	65.0	65.8	66.5	67.9	69.1	—
			4	1.01	84.3	86.0	87.5	89.0	90.4	93.1	95.5	—
			6	2.24	94.6	96.7	98.8	100.7	102.5	106.0	109.3	—
			8	3.97	100.7	103.2	105.5	107.7	109.9	113.9	117.7	—
			Airside Ps		0.16	0.17	0.19	0.20	0.22	0.25	0.28	—

**NOTE:** Heating capacity data in tables assume an entering water temperature (EWT) of 180°F, and an entering air temperature (EAT) of 65°F, which corresponds to a temperature difference of 115°F. Smaller temperature differences will result in a decrease of heating capacity. To obtain the heating capacity at another temperature difference, refer to the hot water coil notes located in the Reference Section.

**Table 72: MQFVI-500 Hot Water Coils Kw Selection Data – Metric Units**

Case Size	Rows	Connection OD (mm)	Water Flow (L/s)	Head Loss (kPa)	Airflow (L/s)							
					94	118	142	165	189	212	236	260
1	One	22.2	0.01	0.42	3.0	3.4	3.7	4.0	4.2	4.4	4.6	4.7
			0.03	1.61	3.4	3.8	4.2	4.5	4.8	5.1	5.3	5.6
			0.13	6.16	3.5	4.0	4.5	4.9	5.2	5.5	5.9	6.1
			0.29	13.51	3.6	4.1	4.6	5.0	5.4	5.7	6.0	6.3
			Airside Ps (kPa)		0.002	0.002	0.002	0.005	0.005	0.01	0.01	0.01
1	Two	22.2	0.01	0.27	4.2	4.7	5.2	5.6	5.9	6.2	6.5	—
			0.02	1.02	4.7	5.5	6.1	6.7	7.2	7.7	8.1	—
			0.08	3.95	5.1	5.9	6.7	7.4	8.1	8.7	9.2	—
			0.19	8.79	5.2	6.1	7.0	7.7	8.4	9.1	9.7	—
			Airside Ps (kPa)		0.005	0.005	0.01	0.01	0.01	0.01	0.01	0.02
					Airflow (L/s)							
					142	165	189	212	236	283	307	330
2	One	22.2	0.01	0.42	3.7	4.0	4.2	4.4	4.6	4.9	5.0	5.2
			0.03	1.61	4.2	4.5	4.8	5.1	5.3	5.8	6.0	6.2
			0.13	6.16	4.5	4.9	5.2	5.5	5.9	6.4	6.6	6.9
			0.29	13.51	4.6	5.0	5.4	5.7	6.0	6.6	6.9	7.1
			Airside Ps (kPa)		0.002	0.005	0.005	0.01	0.01	0.01	0.01	0.01
2	Two	22.2	0.01	0.27	5.2	5.6	5.9	6.2	6.5	6.9	7.1	—
			0.02	1.02	6.1	6.7	7.2	7.7	8.1	8.8	9.1	—
			0.08	3.95	6.7	7.4	8.1	8.7	9.2	10.2	10.6	—
			0.19	8.79	7.0	7.7	8.4	9.1	9.7	10.8	11.3	—
			Airside Ps (kPa)		0.01	0.01	0.01	0.01	0.02	0.02	0.02	0.03
					Airflow (L/s)							
					189	236	283	330	378	425	472	566
3	One	15.9	0.01	0.60	4.9	5.4	5.8	6.1	6.4	6.7	6.9	7.3
			0.05	2.27	5.6	6.3	6.9	7.3	7.8	8.2	8.5	9.1
			0.18	8.61	6.1	6.9	7.6	8.2	8.7	9.2	9.7	10.5
			0.40	18.83	6.3	7.1	7.8	8.5	9.1	9.6	10.1	11.0
			Airside Ps (kPa)		0.002	0.005	0.005	0.01	0.01	0.01	0.01	0.01
3	Two	22.2	0.01	0.30	6.7	7.4	7.9	8.4	8.8	9.1	9.4	—
			0.02	1.17	8.1	9.2	10.1	10.9	11.5	12.1	12.7	—
			0.10	4.51	9.0	10.4	11.6	12.7	13.6	14.5	15.3	—
			0.21	10.04	9.4	10.9	12.2	13.4	14.5	15.5	16.5	—
			Airside Ps (kPa)		0.01	0.01	0.01	0.02	0.02	0.02	0.02	0.03
					Airflow (L/s)							
					378	425	472	519	566	614	661	755
4	One	15.9	0.01	0.60	6.4	6.7	6.9	7.1	7.3	7.4	7.6	7.8
			0.05	2.27	7.8	8.2	8.5	8.8	9.1	9.4	9.6	10.1
			0.18	8.61	8.7	9.2	9.7	10.1	10.5	10.8	11.1	11.7
			0.40	18.86	9.1	9.6	10.1	10.6	11.0	11.4	11.8	12.4
			Airside Ps (kPa)		0.01	0.01	0.01	0.02	0.02	0.02	0.02	0.02
4	Two	22.2	0.01	0.30	8.8	9.1	9.4	9.6	9.8	10.0	10.2	—
			0.02	1.17	11.5	12.1	12.7	13.1	13.6	14.0	14.3	—
			0.10	4.54	13.6	14.5	15.3	16.0	16.7	17.3	17.9	—
			0.21	10.04	14.5	15.5	16.5	17.3	18.1	18.8	19.5	—
			Airside Ps (kPa)		0.02	0.02	0.03	0.04	0.04	0.05	0.05	—
					Airflow (L/s)							
					472	519	566	614	661	708	755	802
5	One	15.9	0.01	0.60	6.9	7.1	7.3	7.4	7.6	7.7	7.8	7.9
			0.05	2.27	8.5	8.8	9.1	9.4	9.6	9.8	10.1	10.3
			0.18	8.64	9.7	10.1	10.5	10.8	11.1	11.4	11.7	12.0
			0.40	18.89	10.1	10.6	11.0	11.4	11.8	12.1	12.4	12.8
			Airside Ps (kPa)		0.01	0.02	0.02	0.02	0.02	0.03	0.03	0.03
5	Two	22.2	0.01	0.30	9.4	9.6	9.8	10.0	10.2	10.4	10.5	—
			0.02	1.17	12.7	13.1	13.6	14.0	14.3	14.7	15.0	—
			0.10	4.54	15.3	16.0	16.7	17.3	17.9	18.4	18.9	—
			0.21	10.04	16.5	17.3	18.1	18.8	19.5	20.2	20.8	—
			Airside Ps (kPa)		0.03	0.04	0.04	0.05	0.05	0.06	0.07	—



					Airflow (L/s)							
					472	519	566	614	661	755	850	944
6	One	15.9	0.01	0.63	7.2	7.4	7.6	7.7	7.9	8.2	8.4	8.6
			0.05	2.42	8.9	9.2	9.5	9.8	10.1	10.5	11.0	11.3
			0.19	9.18	10.1	10.5	11.0	11.3	11.7	12.3	12.9	13.4
			0.42	20.09	10.6	11.1	11.5	11.9	12.3	13.1	13.7	14.3
			Airside Ps (kPa)		0.01	0.01	0.02	0.02	0.02	0.03	0.03	0.04
6	Two	22.2	0.01	0.30	9.7	9.9	10.2	10.4	10.6	10.9	11.1	—
			0.03	1.20	13.1	13.6	14.1	14.5	14.9	15.5	16.1	—
			0.10	4.69	15.8	16.6	17.3	18.0	18.6	19.7	20.7	—
			0.22	10.37	17.0	17.9	18.8	19.6	20.3	21.6	22.8	—
			Airside Ps (kPa)		0.03	0.03	0.03	0.04	0.05	0.06	0.07	—
					Airflow (L/s)							
					944	991	1038	1085	1133	1227	1321	1416
7	One	22.2	0.02	1.02	12.8	13.0	13.2	13.4	13.5	13.8	14.1	14.3
			0.08	3.95	15.8	16.1	16.4	16.6	16.9	17.4	17.8	18.2
			0.19	8.79	17.2	17.5	17.8	18.1	18.4	19.0	19.6	20.1
			0.33	15.51	17.9	18.3	18.7	19.0	19.3	20.0	20.6	21.1
			Airside Ps (kPa)		0.02	0.02	0.02	0.02	0.02	0.03	0.03	0.04
7	Two	22.2	0.02	0.78	18.5	18.8	19.0	19.3	19.5	19.9	20.2	—
			0.06	3.02	24.7	25.2	25.6	26.1	26.5	27.3	28.0	—
			0.14	6.70	27.7	28.3	28.9	29.5	30.0	31.0	32.0	—
			0.25	11.87	29.5	30.2	30.9	31.5	32.2	33.3	34.5	—
			Airside Ps (kPa)		0.04	0.04	0.05	0.05	0.05	0.06	0.07	—

**NOTE:** Heating capacity data in tables assume an entering water temperature (EWT) of 82°C, and an entering air temperature (EAT) of 18°C, which corresponds to a temperature difference of 64°C. Smaller temperature differences will result in a decrease of heating capacity. To obtain the heating capacity at another temperature difference, refer to the hot water coil notes located in the Reference Section.

**Figure 23: MQFVI-500 ECM Fan Performance Curves Unit Size 1**

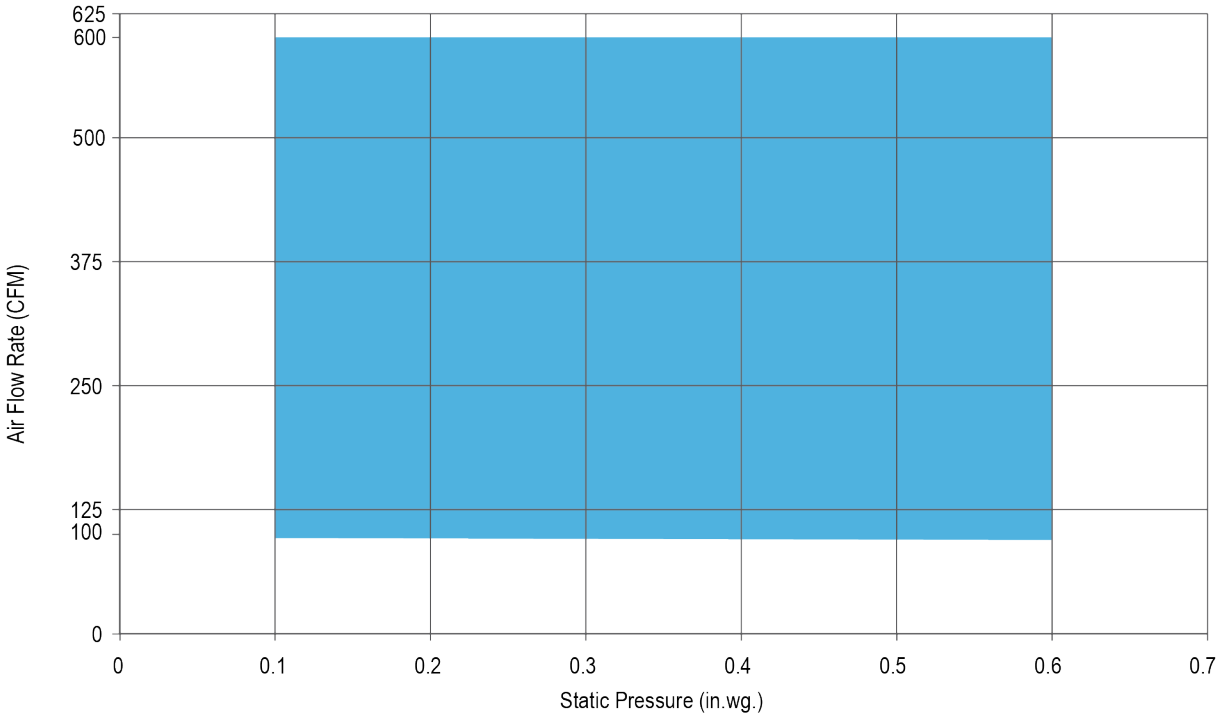

**Figure 24: MQFVI-500 ECM Fan Performance Curves Unit Size 2**

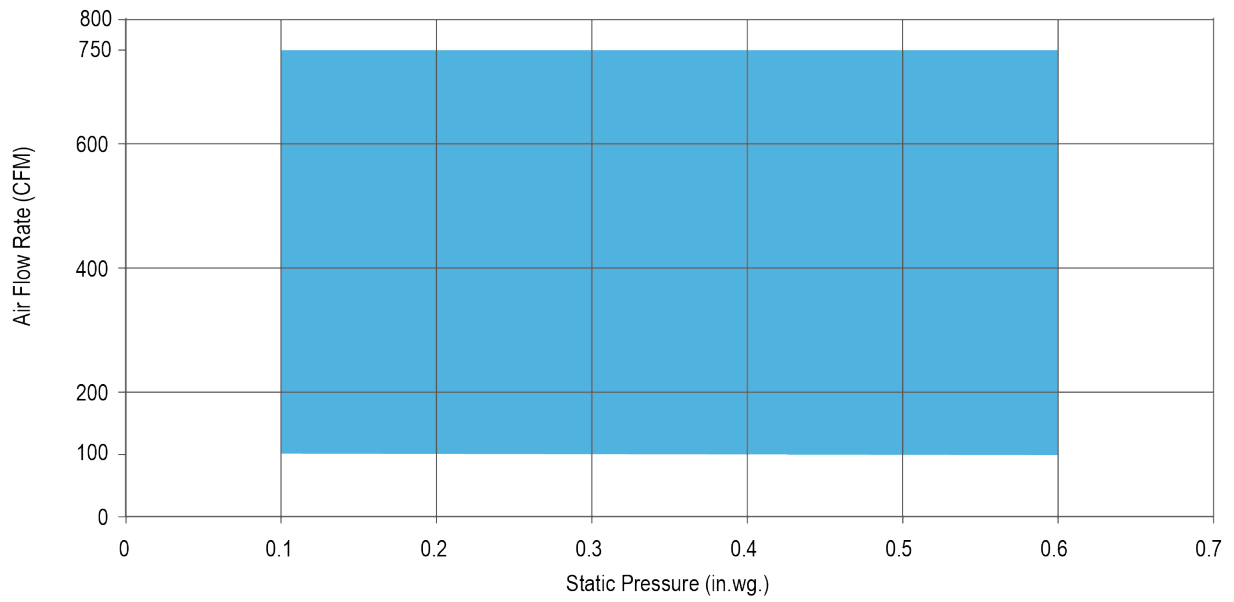

**Figure 25: MQFVI-500 ECM Fan Performance Curves Unit Size 3**

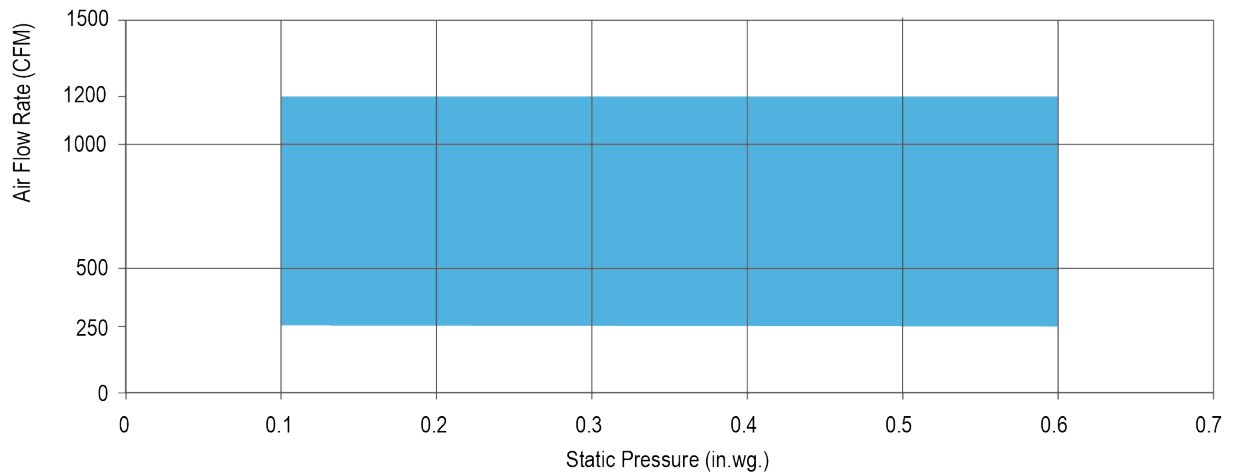

**Figure 26: MQFVI-500 ECM Fan Performance Curves Unit Size 4**

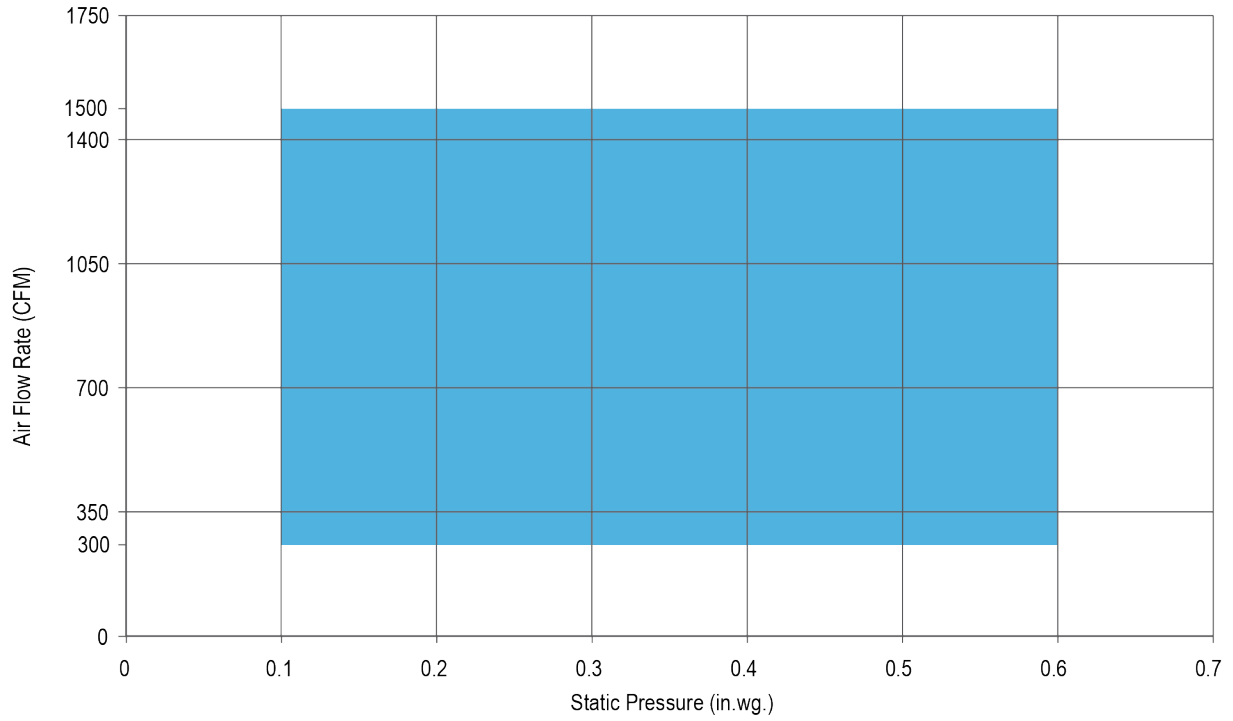

**Figure 27: MQFVI-500 ECM Fan Performance Curves Unit Size 5**

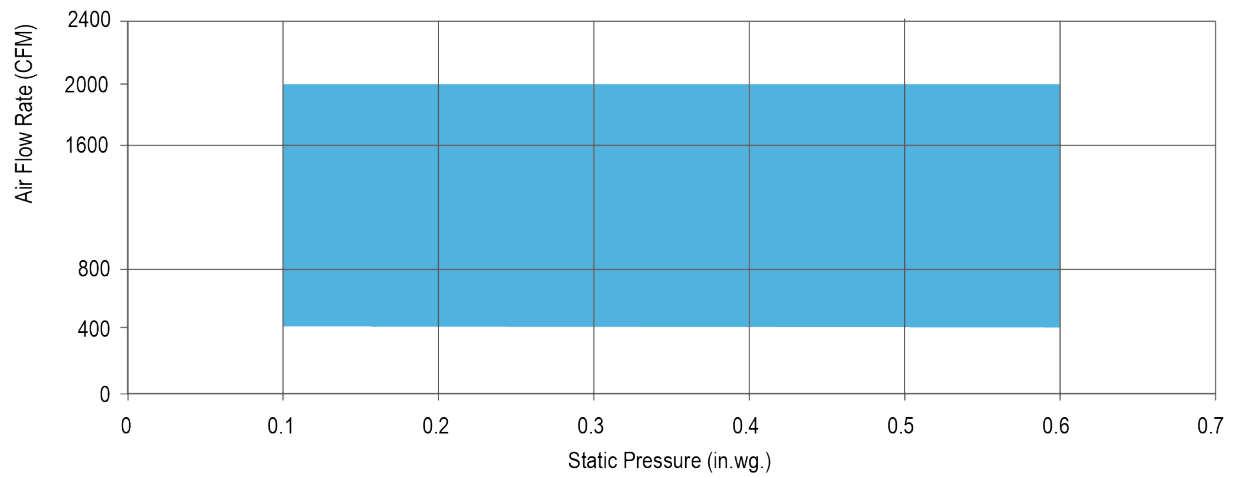

**Figure 28: MQFVI-500 ECM Fan Performance Curves Unit Size 6**

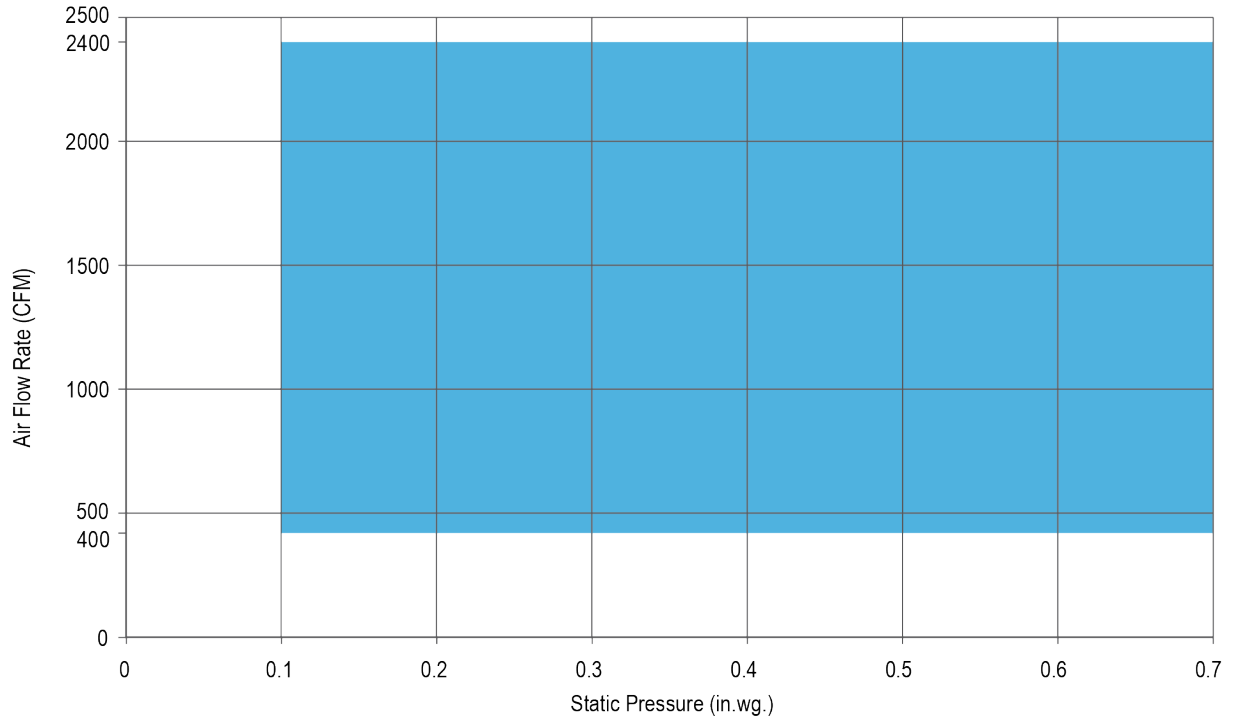

**Figure 29: MQFVI-500 ECM Fan Performance Curves Unit Size 7**

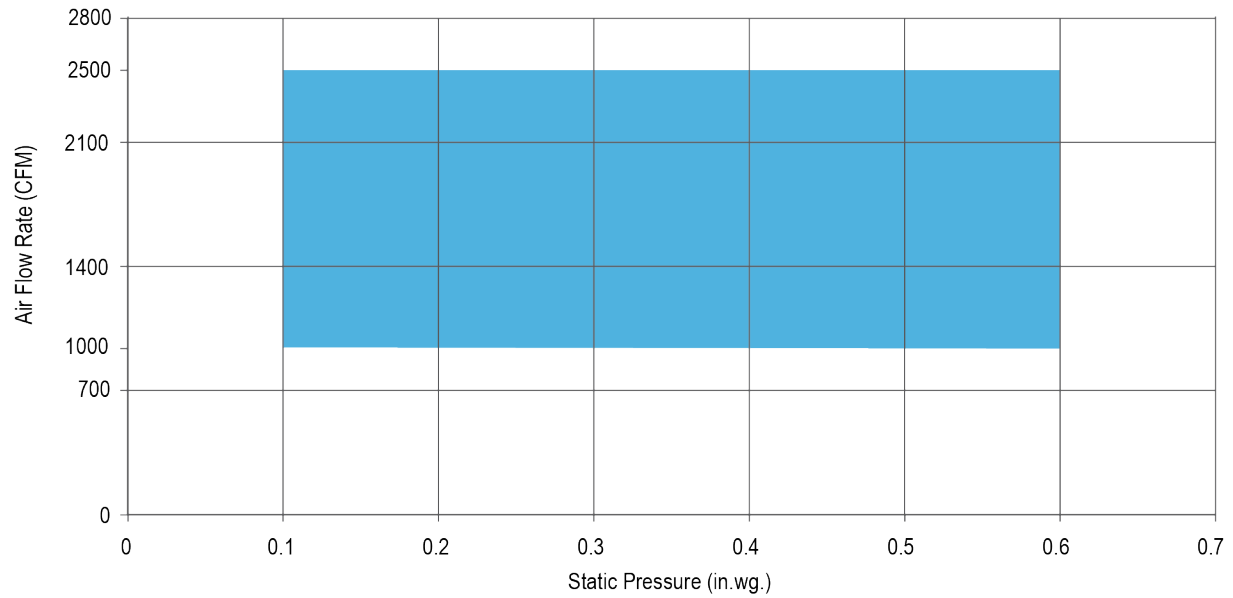

## Hot Water Coils

When ordered with the air terminal, the hot water coil is shipped attached to the discharge of the terminal casing. The discharge end of the casing has slip and drive connections for easy connection to downstream ductwork. The hot water coil is constructed of aluminum fin and copper serpentine-type tubes with male sweat connections tested at 300 psig.

Coil selection may be made using Daikin Select Tools selection software. Contact your Daikin Applied representative for a copy. In the interest of energy conservation and due to the possibility of condensation, all hot water coils are marked, "Coil must be externally insulated after installation in the field." Hot water coils are tested in accordance to AHRI. Options, at an additional charge on hot water coils, include access doors for inspection and cleaning, and inlet/outlet on opposite sides of coils.

All accessories which can be attached to the Parallel Fan Boxes are not a part of the AHRI certification program but ratings can be affected by their use.

### Hot Water Coil Construction Details

- Hot Water Coils are factory mounted to the discharge of the terminal and are available with an optional factory mounted discharge plenum section with access door
- Hot water coils are enclosed in a 20 gauge coated steel casing allowing for attachment to metal ductwork with a slip and drive connection
- Fins are rippled and sine wave type constructed from heavy gauge aluminum and are mechanically bonded to the tubes
- Tubes are copper with a minimum wall thickness of 0.016" with male solder header connection.
- Coils are leak tested to 300 psi with minimum burst of 2000 psi at ambient temperature. Coil performance data is based on tests run in accordance with AHRI standard 410. Coils are AHRI certified and include an AHRI label

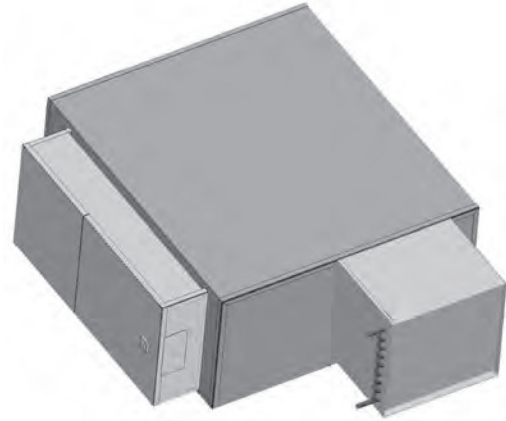

**Table 73: Hot Water Tubing Connections**

Case Size	Standard HW Coil, inches (mm)	
	1 Row	2 Row
1	7/8 (22.2)	7/8 (22.2)
2	7/8 (22.2)	7/8 (22.2)
3	5/8 (15.8)	7/8 (22.2)
4	5/8 (15.8)	7/8 (22.2)
5	7/8 (15.8)	7/8 (22.2)
6	7/8 (15.8)	7/8 (22.2)
7	7/8 (22.2)	7/8 (22.2)

**NOTE:** All coils have 10 fins per inch.

**Table 74: Hot Water Outlet Dimensions**

Case Size	Standard HW Coil, inches (mm)	
	H	W
1	15 (381)	16 (406)
2	15 (381)	16 (406)
3	17.5 (445)	20 (508)
4	17.5 (445)	20 (508)
5	17.5 (445)	20 (508)
6	18 (457)	22 (559)
7	20 (508)	30 (718)

## Electric Heat

Electric heater elements, as illustrated on this page, are integral to the air terminal. The discharge end has slip and drive connections for easy connection to downstream ductwork. ETL® listed heaters are provided with a fan interlock relay. Heaters that will be controlled electronically must include a 24 VAC control circuit to operate with the low voltage controls on the air terminal. Heater plenums are internally insulated. When an air terminal is ordered with clean room lining and electric heat, the heater plenum is either internally lined with optional foil backed insulation or closed cell foam or may require external insulation in field.

All accessories which can be attached to the Parallel Fan Boxes are not a part of the AHRI certification program but ratings can be affected by their use.



### Electric Heater Assembly Construction Details

Electric Reheat Coils are factory mounted on the discharge of the Air Terminal. The heaters are ETL® listed for zero clearance, are tested in accordance with UL® Standard 1995, CSA-C22.2 No. 236 and the National Electric Code (NEC). Heater casings are constructed of heavy-duty zinc-coated steel. Element wire is high grade nichrome alloy derated to 45 watts per square inch density. Element wire is supported by moisture-resistant steatite ceramics.

Ceramics are enclosed in reinforcement brackets spaced across the heater element rack at 2" to 4" intervals. Controls are contained in a NEMA 1 control cabinet with a hinged, latching door. A permanent wiring diagram is affixed to the inside of the control cabinet door for field reference.

The 208 and 480 volt units require a neutral connection for both single and three phase service. Our standard motors are 120 and 277 volt single phase. The 208-240 volt single phase motor is optional. 480 volt motors are not available for our units. See [Table 75](#) for reference.

#### **Included with Each Heater Assembly:**

- Heater and cabinet mounted on the discharge of the MQFVI-500
- Electric heater is interlocked into fan control relay
- De-energizing magnetic contactors per step
- Primary automatic reset high temperature limit (disc type)
- Backup manual reset high temperature limit (disc type)
- Non-fused transformer with voltage to match heater voltage
- Single point power wiring connection
- Heater is shipped factory mounted and wired

**Table 75: Electric Heat Information**

Heater Voltage	Motor Voltage	Separate Neutral Required
120 V 1PH	120 V 1PH	NO
208 V 1PH	120 V 1PH	YES
277 V 1PH	277 V 1PH	NO
480 V 1PH	277 V 1PH	YES
208 V 1PH	208 V 1PH	NO
208 V 3PH	120 V 1PH	YES
480 V 3PH	277 V 1PH	YES
208 V 3PH	208 V 1PH	NO

**Table 76: MQFVI-500 Electric Heater Capacities**

Single Phase MQFVI kW Limits				
Case Size	Heater Voltage	Min. kW Step	Max. kW	Max. Steps
1	120	0.5	5	2
1	208	0.5	8.5	2
1	240	0.5	10	2
1	277	0.5	11.5	2
1	480	0.5	11.5	2
2	120	0.5	5	2
2	208	0.5	8.5	2
2	240	0.5	10	2
2	277	0.5	11.5	2
2	480	0.5	11.5	2
3	120	0.5	5	3
3	208	0.5	8.5	3
3	240	0.5	10	3
3	277	0.5	11.5	3
3	480	0.5	11.5	3
4	120	0.5	5	3
4	208	0.5	8.5	3
4	240	0.5	10	3
4	277	0.5	11.5	3
4	480	0.5	17	3
5	120	0.5	5	3
5	208	0.5	8.5	3
5	240	0.5	10	3
5	277	0.5	11.5	3
5	480	0.5	17	3
6	120	0.5	5	3
6	208	0.5	8.5	3
6	240	0.5	10	3
6	277	0.5	11.5	3
6	480	0.5	17	3
7	120	0.5	5	3
7	208	0.5	8.5	3
7	240	0.5	10	3
7	277	0.5	11.5	3
7	480	0.5	17	3

**NOTE 1:** Heaters equal to or less than 5 kW are specifiable to the nearest 0.2 kW. Heaters greater than 5 kW and less than 10 kW are specifiable to the nearest 0.5 kW. Heaters less than 5 kW are specifiable to the nearest 0.2 kW. Heaters greater than 5 kW and less than 10.0 kW are specifiable to nearest 0.5 kW. Heaters greater than 10.0 kW are specifiable to nearest 1.0 kW.

**NOTE 2:** Minimum flow rate for electric heat is 70 CFM/kW. Lower CFM's can cause nuisance tripping, excessive discharge temperatures, rapid cycling and rapid element failure. Electric Heat units running below 70 CFM/kW will void all warranties.

**NOTE 3:** For optimum thermal comfort, the suggested discharge temperature should not exceed 20°F above room set point.

**NOTE 4:** We do not recommend discharge temperatures in excess of 115°F to protect heater coils.

**NOTE 5:** Maximum number of steps at minimum kW is one step.

**NOTE 6:** If more than 1 heater is wired into a building's circuit breaker (multi-outlet branch circuit), each heater will require the addition of power side fusing.

Three Phase MQFVI kW Limits				
Case Size	Heater Voltage	Min. kW Step	Max. kW	Max. Steps
1	208	0.5	13	2
1	240	0.5	14.5	2
1	480	10.5	17	2
2	208	0.5	13	2
2	240	0.5	14.5	2
2	480	1.5	17	2
3	208	0.5	13	3
3	240	0.5	14.5	3
3	480	1.5	17	3
4	208	0.5	13	3
4	240	1.5	15	3
4	480	1.5	25	3
5	208	0.5	13	3
5	240	1.5	15	3
5	480	1.5	25	3
6	208	0.5	13	3
6	240	1.5	15	3
6	480	1.5	25	3
7	208	0.5	13	3
7	240	1.5	15	3
7	480	1.5	25	3

**Electric Heat Selection:**

- A. Specify electric duct heaters using voltage, kW, and number of steps.
- B. Use above chart to select voltage. Calculate required kW using following equations:

$$kW = \frac{BTU / HR}{3413} \quad kW = \frac{CFM \times \Delta \times 1.085}{3413} \quad \Delta = \frac{kW \times 3413}{CFM \times 1.085}$$

$$CFM = \frac{kW \times 3413}{\Delta \times 1.085} \quad CFM = \frac{kW \times 3413}{\Delta \times 1.085}$$

\* Air density at sea level—reduce by 0.036 for each 1000 feet of altitude above sea level

Where: BTU / Hr = Required heating capacity

CFM = volume of air during heating. Typically 100% of maximum cooling air volume

Δ = desired air temperature rise across the electric heater

Inlet air temperature = primary air temperature, usually 55°F

## Options and Accessories

For a complete list of available options, please contact your Daikin Applied representative.

### Control Enclosures

- Dust tight control enclosures available for all units. The damper control enclosure is provided sealed to prevent light or dust from entering the enclosure when the cover is in place

### Filters

- Fan powered units have optional filter racks with filters. Filters are installed at the fan air intake and have a MERV 6-7 rating

### Handing

- All single duct units are configured with controls and coil connections on the right as standard (looking in direction of airflow). Optional configurations include controls on left, coil connections on right; controls on right, coil connections on left; and both controls and coil connections on the left
- All fan powered units are configured with the controls and coil connections on the left as standard (looking in direction of airflow). Optional configurations include controls on left, coil connections on right; controls on right, coil connections on left; and both controls and coil connections on right. Optional handing not available on the MQFVI unit if the coil is mounted on the induction.

### Construction Options

- 20 gauge construction available on all units
- Hanger brackets available for all units. Metal “L” brackets (4 per unit) which are shipped loose for field installation. Brackets are provided with a 5/8” diameter hole and vibration isolation grommet
- Inlet attenuators available for fan powered units. The opening is on the side of the box, and the insulation type will match whatever is chosen for the unit. With an induction mounted coil, the filter is on either the top or bottom

Figure 30: Position of Filter with Induction Mounted Coil



### Hanger Brackets

Hanger brackets are shipped loose for field installation. The optional hanger brackets (4) are bagged and placed inside the control enclosure on each air terminal.

Hanger bracket kit includes:

- (4) Hanger Brackets
- (12) Sheet Metal Screws
- (4) Isolation Grommets

Figure 31: Hanger Brackets

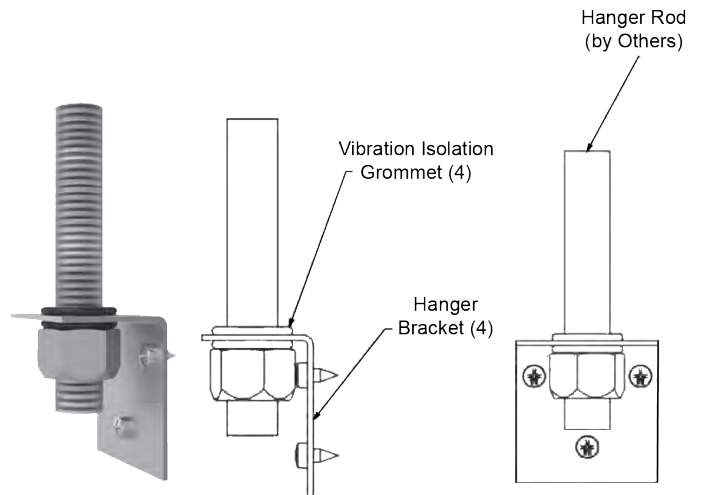



## Inlet Elbow Attenuator for Fan Powered Terminal Units

The inlet elbow attenuator is designed to reduce the radiated noise of fan powered terminal units. The standard inlet elbow attenuator is manufactured from 22 gauge metal and is lined with the same insulation material as the terminal unit it is mounted to. Optional 20 gauge construction and various types of insulation are also available. The standard inlet elbow attenuator is factory installed and ships as an integral part of the terminal. Depending on the terminal unit model and case size, attenuator lengths vary from 16-24". The [Table 77](#) lists the insertion loss credits for the inlet elbow attenuator.

**Table 77: Insertion Loss for Inlet Elbow Attenuator**

dB	CFM					
	125	250	500	1000	2000	4000
	1	4	6	7	10	12

**NOTE 1:** 22 ga. Galvanized steel casing

**NOTE 2:** 1.5 lbs/ft<sup>3</sup> dual density coated fiberglass insulation

**NOTE 3:** Insulation meets standards UL 181 and NFPA 90A

**NOTE 4:** Performance data is obtained from laboratory testing in accordance with AHRI 880-2011

## Insulation

- All units available with dual density fiberglass insulation. Available thicknesses are 1/2" and 1"
- All units available with foil-faced fiberglass insulation, 1.5 lbs density. Available thicknesses are 1/2", 3/4" and 1"
- All units are available with foil-faced fiberglass insulation, 4 lbs density. Only available in 1" thickness.
- All units available with ThermoPure closed cell foam insulation. Available thicknesses are 1/2" and 1"
- Single duct (TH) units are available with solid double-wall/ metal lined insulation. The double wall is available with either 1/2" or 1" fiberglass insulation between the unit and metal liner

Many insulation types are available for use in air terminal units. Each type and thickness of insulation has different thermal and acoustical characteristics as well as unit cost. It is important when specifying any type of insulation to specify not only the material, but the thickness and density as well. For instance, a common fiberglass specification is 1" thick, dual density (1.5 lbs/ft<sup>3</sup> min.) fiberglass insulation. For all insulations, the thicker the insulation, the greater the acoustical and thermal performance, and the higher the cost.

Generally, insulation erosion resistance is stated with respect to UL 181 erosion test. Insulation meeting this specification will not erode or otherwise contribute particulate to the airstream at velocities up to 2500 fpm. Also, insulation is regulated regarding the restriction of fire and smoke spread by NFPA 90A, which requires insulation to be tested at a minimum of 250°F. All insulations offered by Daikin Applied meet UL 181 and NFPA 90A requirements.

## Fiberglass

The most common type of insulation applied to ATU boxes is fiberglass. Fiberglass insulation is relatively inexpensive, and provides good thermal and acoustical performance. In most cases, some type of binder is applied to the airstream-facing side of the fiberglass to minimize fiber erosion. This is referred to as 'dual density' insulation as the density of the coated material 'skin' is greater than the core material.

## Foil-Faced Fiberglass Insulation

In situations where erosion resistance above that of dual density is required, foil-faced insulation may be specified. The material, commonly referred to as FSK (foil scrim kraft) facing is adhered to the face of the fiberglass insulation. Critical to the specification is whether or not the FSK material is to be included in the overall material density. Generally, the density of the underlying insulation should be clearly stated.

## Closed-Cell Foam Insulation

Closed-cell foam has acoustical and thermal properties at near parity to dual density fiberglass. In addition to its non-fibrous composition, the material resists mold and mildew growth and is easily cleanable. The material will not wick moisture on exposed edges. The material is more costly than dual density fiberglass and this must be considered when specifying the material.

## Double-Wall Insulation

For very stringent specifications where fiber erosion must be completely eliminated as a possibility, solid or double wall metal liners have been specified. These liners are extremely expensive and negatively affect the sound performance of the terminal unit to which it is applied.

## Access Options

### Motor/Blower Access

- Typical standard motor/blower access panel with zip screws

**Figure 32: Motor/Blower Access**



## Coil Access

On fan powered terminals with discharge mounted hot water coils that require an access door, a section of insulated duct is added to the discharge of the terminal upstream of the coil.

All coil access doors are insulated with ThermoPure closed cell fiber free insulation. The closed cell foam insulation is used for achieving an air tight seal on the access door. Also, by using the closed cell foam insulation there is no concern for the access door insulation tearing or the edge coating seal being damaged during removal.

**Figure 33: Coil Access**

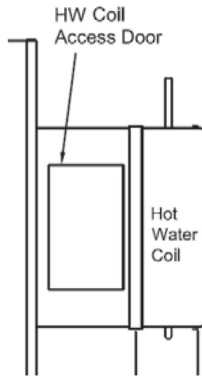

## Inlet Flow Sensors

### Multi-Quadrant Averaging Flow Sensor

Daikin Applied's standard airflow sensor is a multi-quadrant averaging sensor, suitable for use in most differential pressure feedback air control circuits. The accuracy or minimum-maximum set point is  $\pm 5\%$  or less when calibration is accurately performed.

**Table 78: Multi-Quadrant Averaging Flow Sensor**



## Inlet Flow Sensor Ports

Daikin Applied air terminal units are provided with external piping sensor connections, allowing visual verification of inlet sensor piping connections without having to remove the primary duct or relying solely on tubing color coding.

The units are shipped with blue stripe tubing on the high pressure port and red stripe tubing on the low pressure port of the inlet sensor. The tubing are short pieces with barbed fittings. The "HIGH" pressure side of the inlet flow sensor is what the air hits first and the "LOW" pressure side of the inlet flow sensor is farthest away from the airflow. All diagrams display the color of tubing used on the "HIGH" and "LOW" pressure ports of the inlet flow sensor.

**Figure 34: Inlet Flow Sensor Ports**

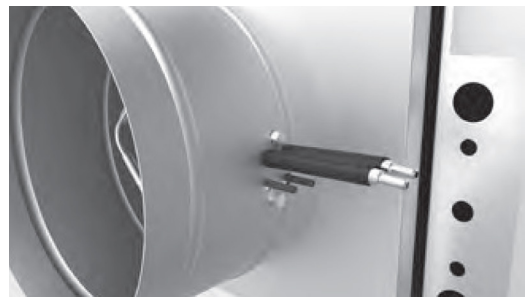

**Table 79: Round Duct Dimensions**

Size	D (in)
04	4
05	5
06	6
08	8
10	10
12	12
14	14
16	16

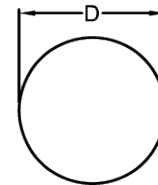

**Table 80: Rectangular Duct Dimensions**

Size	W (in)	H (in)
14x8	14	8
16x8	16	8
20x16	20	16
24x16	24	16

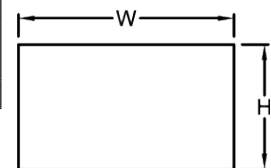
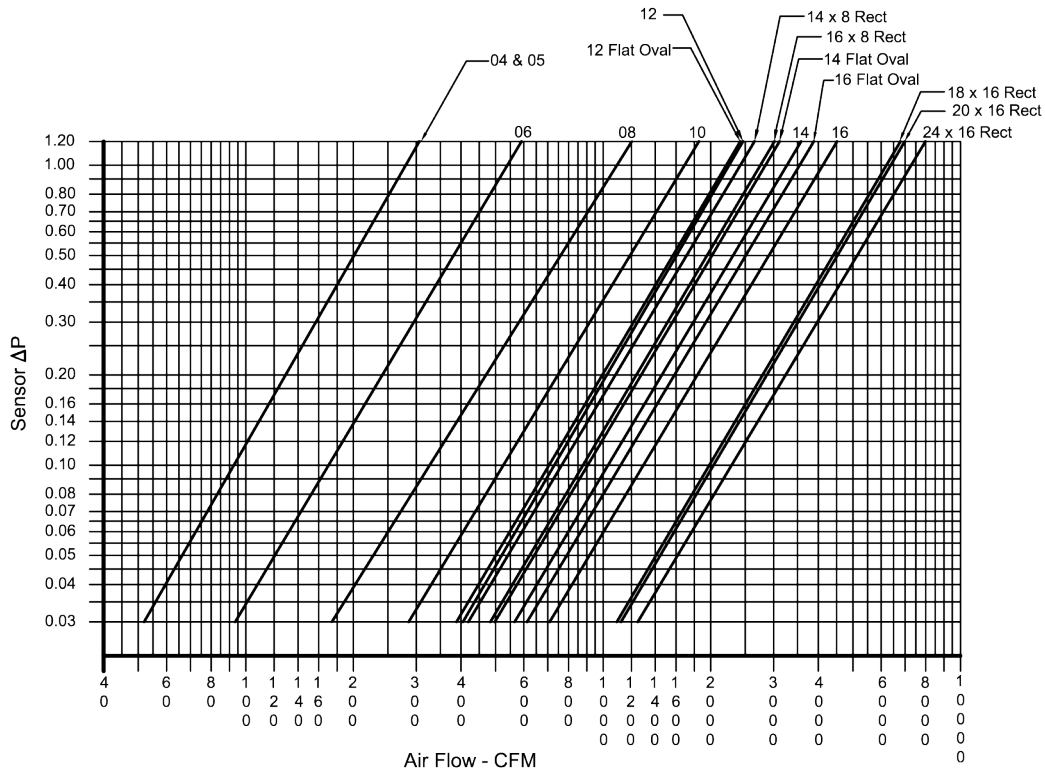

Figure 35: Multi-Quadrant Averaging Flow Sensor Coefficient Chart

$$C_{fm} = \sqrt{\Delta p} \times \text{Flow Coefficient}$$



Data per Test Number T-1103  
Sensors tested down to 0.005 ΔP.

Table 81: Flow Coefficient by Size

Model	Inlet Size	Flow Coefficient	Magnification Factor
TH, FCI, FVI	04, 05 RND	300	6.65
	06 RND	540	2.12
	08 RND	990	1.99
	10 RND	1640	1.77
	12 RND	2350	1.79
	14 RND	3250	1.74
	16 RND	4100	1.86
FVL C4	14x8 RCT	2450	1.62
FCL C4	16x8 RCT	2770	1.65
FCI, FVI C7	18x16 RCT	6200	1.67
TH20	20x16 RCT	6430	1.92
TH24	24x16 RCT	7270	2.16

## Primary Air Dampers

The Daikin Applied damper blade is manufactured with a flexible gasket and mounted without adhesives to provide an excellent close off seal. Included on the damper gasket are slits around the perimeter to prevent damper noise at low turn down. The damper is constructed of double thick 18-gauge equivalent steel. Damper leakage is less than 1% of maximum CFM at 3.0 in.w.g. static pressure.

Daikin Applied has designed the primary air damper shaft assembly for improved performance. The shaft is a one-piece, continuous shaft extruded from aluminum alloy. The shaft has a straightness tolerance of 0.010 in/ft which provides extremely smooth operation. Determining damper position is straightforward since the shaft has a built-in damper position indicator. The indicating arrows provide a high-contrast against the shaft interior for easily visible damper position confirmation. The continuous shaft is much stronger than multiple-piece shaft assemblies, which rely on a thin damper blade to span the middle part of the damper assembly, thus eliminating the opportunity for flexing and twisting of the damper blade.

**Figure 36: Damper Position Indicator**

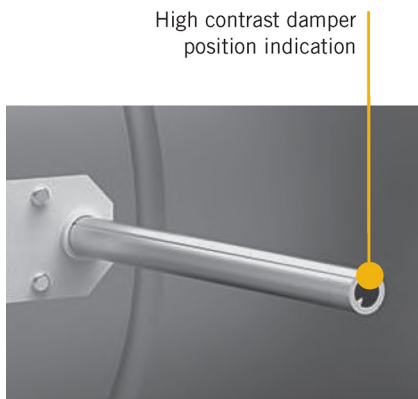

**Figure 37: Damper Blade Construction**

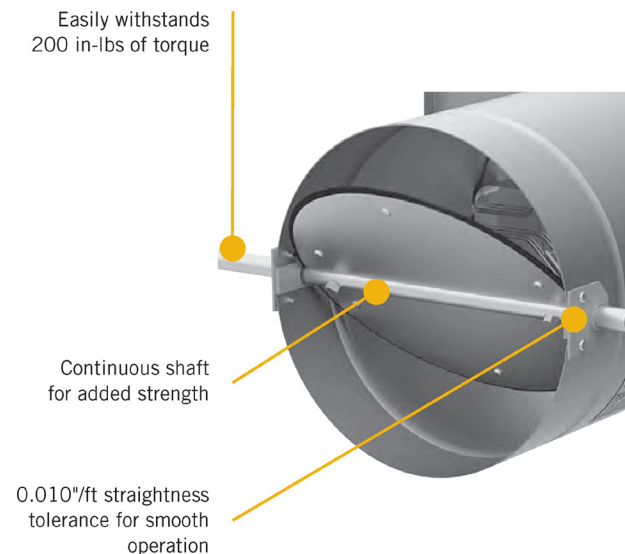

## Hot Water Coils

### Water Flow In Coil

For optimum performance, a water coil should have the water flowing counter to the direction of airflow (counter flow). If the water is run in the same direction as the airflow (parallel flow), the performance will be approximately 96% of the counter flow performance on a 3 row coil and 98% on a 2 row coil.

A coil should always be selected at 0.5 gpm or greater for Daikin Applied coils. If the gpm is below 0.5, the flow becomes laminar; turbulent flow is required for the heat transfer calculations to be valid.

### Coil Venting and Draining

When water is supplied to the coil the flow is in an upward direction, taking the air to the top of the coil and out the return connection. When the coil is to be drained, there will be no trapped water remaining in the coil circuitry; all water will drain out of the supply connection.

**Figure 38: Coil Water Flow**

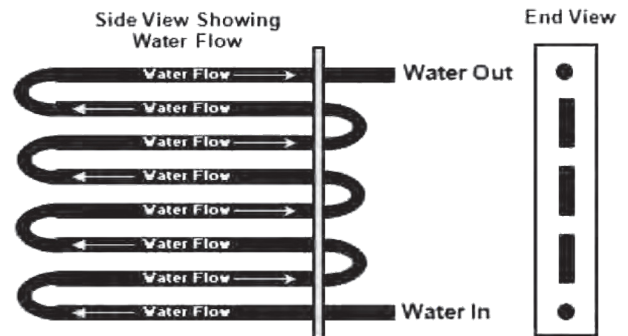

## Coil Performance

- Hot water coil data is for discharge mounted coils
- For water valve sizing, contact your Daikin Applied representative. For data values other than those listed, interpolate using the Daikin Select Tools selection software
- Daikin Applied coil data is AHRI 410 certified

**Table 82: Temperature Conversion Factors - Imperial**

Temperature Conversion Factors - Imperial										
ΔT (°F)	50	60	70	80	90	100	115	125	140	150
<b>Factor</b>	0.44	0.52	0.61	0.70	0.79	0.88	1.00	1.07	1.20	1.30

**NOTE 1:** Tabulated values are in MBH (thousands of BTU/hr)

**NOTE 2:** Head loss is in feet of water

**NOTE 3:** MBH values are based on a ΔT (temperature difference) of 115°F between entering air and entering water. For other ΔTs, multiply the MBH value by the factors shown:

Air Temperature Rise = 927 × MBH/CFM

Water Temperature Drop = 2.04 × MBH/GPM

**Table 83: Temperature Conversion Factors - Metric**

Temperature Conversion Factors - Metric									
ΔT (°C)	30	35	40	50	60	64	70	80	
<b>Factor</b>	0.48	0.55	0.63	0.78	0.94	1.00	1.08	1.24	

### Metric Notes

**NOTE 1:** Tabulated values are in kW (thousands of Watts)

**NOTE 2:** Head loss is in kPa

**NOTE 3:** kW values are based on a ΔT (temperature difference) between entering air and entering water of 64°C. For other ΔTs, multiply the kW values by the factors shown:

Air Temperature Rise = 579 × kW/Air Flow (L/s)

Water Temperature Drop = 0.17 × kW/Water Flow (L/s)

## Electric Heat

### Optional Accessories For Electric Heaters

#### Special Features:

- Disconnecting break magnetic contactors
- Fusing per step – all voltages / phase combinations
- Line-disconnect fusing

#### Fused Transformers:

- Transformer with fused primary
- Transformer with fused secondary
- Transformer with both fused primary and secondary

#### SSR Solid State Electronic Controls:

- 2 – 10 VDC
- 4 – 20 mA
- Pulse Width Modulation

#### Disconnect Switches:

- Door interlocking non-fused disconnect switch

## Disconnecting Break Contactors

Disconnecting break contactors break all ungrounded (hot) power leads when the contactor opens. In the case of 3-phase power, all 3 phases are broken simultaneously. For single phase power where both leads are ungrounded (208-240V), both leads are broken simultaneously.

When only one lead is ungrounded (120 or 277V) the other (neutral) does not need to be broken. When using a 1-pole contactor, there is no difference between 'disconnecting' and 'de-energizing'.

## De-Energizing Break Contactors

For de-energizing break contactors, only enough leads need to be broken to de-energize (turn off) the heater. For 3-phase power, 2 of the 3 leads are broken to achieve this. In single phase power, with 208-240V, only one of the leads needs to be broken. For single phase, 120 or 277V, only the underground lead will break (1-pole).

### Total Amps Calculation

- Heater Amps Single Phase = (kW × 1000) / (Line Voltage)
- Heater Amps Three Phase = (kW X 1000) / (Line Voltage × 1.732)
- Motor FLA is the nameplate amp rating of a given motor (depends on HP and Voltage)
- Total Circuit Amps = (Heater Amps + Motor FLA)
- Minimum Circuit Ampacity = (Total Circuit Amps × 1.25)
- Maximum Overcurrent Protection = (Minimum Circuit Ampacity) rounded up to the nearest standard fuse or HACR circuit breaker size.

## Electric Heat Wiring

All units with electric heat are single-point electrical connection devices. The power supply voltages can be single or three phase. See [Table 84](#) for voltage availability and requirements. In all cases of three phase power, only 3 wires of a 4-Wire supply will be used. A separate neutral is not required.

- 120 volts, single phase is derived from a 208 volt, 3-phase, 4-wire supply. The voltage is taken from the grounded neutral and any one of the 3 hot legs
- 220 volts, single phase (usually 50/60 Hz, Overseas) is derived from a 380 volt, 3-phase, 4-wire supply. The voltage is taken from the grounded neutral and any one of the 3 hot legs
- 240 volts, single phase can be derived from 2 possible sources:
  - Domestically, it is usually a stand alone transformer supplying a 3-phase, 3-wire supply and has no neutral. The exception is the residential market where the transformer has a center tapped grounded neutral to supply 120 volts for normal household usage with 240 volts available for heavy appliances, such as central A/C, Cooking Ranges, and Electric Clothes Dryers.
  - Commercially, it is usually derived from a 415 volt, 3-phase, 4-wire supply. The voltage is taken from the grounded neutral and any one of the 3 hot legs.

- 277 volts, single phase, is derived from a 480 volt, 3-phase, 4-wire supply. The voltage is taken from the grounded neutral and any one of the 3 hot legs
- 208 volts and 480 volts, 3-phase may not have a separate neutral available in some older buildings. This is called a Delta connected supply transformer. All 4-wire supplies are Wye connected transformers. This is not a concern with single duct units, since a separate neutral is not required

**Table 84: Single Duct Electrical Information**



Supply Volts	Phase	No. of Wires
120	1	2
208	1	2
220	1	2
240	1	2
277	1	2
380	1	2
415	1	2
480	1	2
415	1	2
208	3	3
240	3	3
415	3	3
380	3	3
480	3	3

**Table 85: Fan Powered Unit Electrical Information**



Heater Voltage	Motor Voltage	Separate Neutral Required
120 V, 1 PH	120 V, 1 PH	NO
208 V, 1 PH	120 V, 1 PH	YES
277 V, 1 PH	277 V, 1 PH	NO
480 V, 1 PH	277 V, 1 PH	YES
208 V, 1 PH	208 V, 1 PH	NO
208 V, 3 PH	120 V, 1 PH	YES
480 V, 3 PH	277 V, 1 PH	YES
208 V, 3 PH	208 V, 1 PH	NO

# Electric Heat – Typical Wiring Diagrams

Figure 39: 208/240/408V, Single Phase, SCR EH

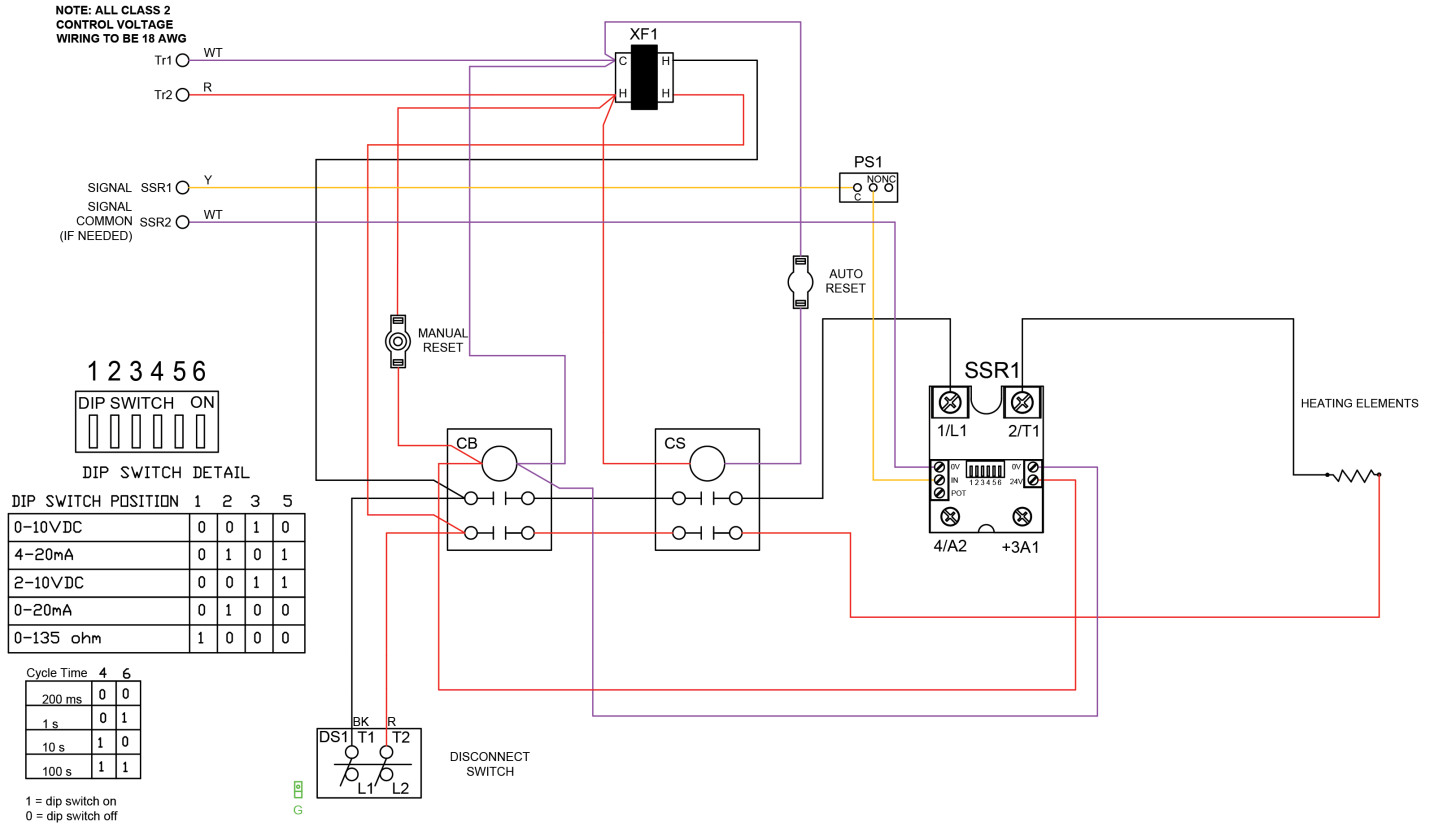

**CAUTION**  
Unit shall be grounded in accordance with N.E.C. Power must be off while servicing.

Wire Color Code					
<b>BK</b>	Black	<b>BL</b>	Blue	<b>BR</b>	Brown
<b>GN</b>	Green	<b>GY</b>	Gray	<b>LT BL</b>	Light Blue
<b>O</b>	Orange	<b>PK</b>	Pink	<b>PR</b>	Purple
<b>R</b>	Red	<b>WT</b>	White	<b>Y</b>	Yellow

LEGEND			
<b>CB</b>	Backup Contactor	<b>SSR1</b>	Solid State Relay 1
<b>CS</b>	Safety Contactor	<b>XF1</b>	Transformer Voltage - 480/24
<b>DS1</b>	Disconnect, Line Voltage - 480/1	---	Field Wired
<b>PS1</b>	Air Pressure Switch	---	Factory Supplied and Wired

- NOTE 1:** All class 2 control voltage wiring to be 18 AWG.
- NOTE 2:** Plug connection to controller. Wire gauge main = 0, Step = 0, Jumper = 0. Wire gauge varies by configuration. Refer to the unit wiring diagram.
- NOTE 3:** Use copper conductors only.
- NOTE 4:** 140°F (60°C) for terminals rated less than 100 amps.
- NOTE 5:** 167°F (75°C) for terminals rated 100 amps or more.
- NOTE 6:** Field control wiring resistance should not exceed 0.75 ohm.

Figure 40: 208/240/408V, Fused Disconnect, Three Phase, SCR EH

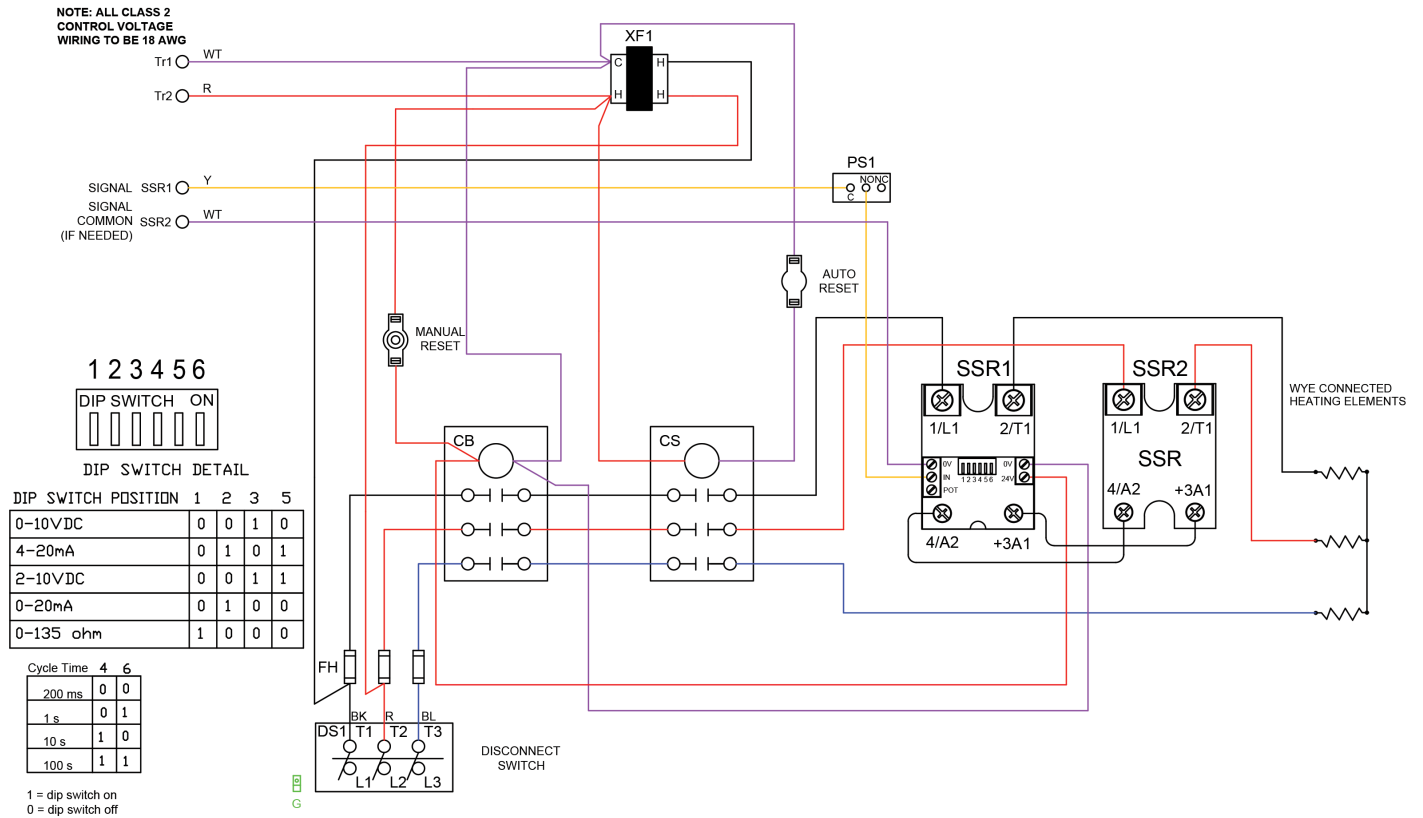

**CAUTION**  
Unit shall be grounded in accordance with N.E.C. Power must be off while servicing.

Wire Color Code					
BK	Black	BL	Blue	BR	Brown
GN	Green	GY	Gray	LT BL	Light Blue
O	Orange	PK	Pink	PR	Purple
R	Red	WT	White	Y	Yellow

LEGEND			
CB	Backup Contactor	SSR1	Solid State Relay 1
CS	Safety Contactor	SSR2	Solid State Relay 2
DS1	Disconnect, Line Voltage - 480/3	XF1	Transformer Voltage - 480/24
FH	Heat Fuse, Class CC Fuse, Rated 600 V, 15 amps	- - - -	Field Wired
PS1	Air Pressure Switch	_____	Factory Supplied and Wired

**NOTE 1:** All class 2 control voltage wiring to be 18 AWG.

**NOTE 2:** Plug connection to controller. Wire gauge main = 0, Step = 0, Jumper = 0. Wire gauge varies by configuration. Refer to the unit wiring diagram.

**NOTE 3:** Use copper conductors only.

**NOTE 4:** 140°F (60°C) for terminals rated less than 100 amps.

**NOTE 5:** 167°F (75°C) for terminals rated 100 amps or more.

**NOTE 6:** Field control wiring resistance should not exceed 0.75 ohm.



Figure 41: 208/240/408V, Three Phase, 1 Stage EH

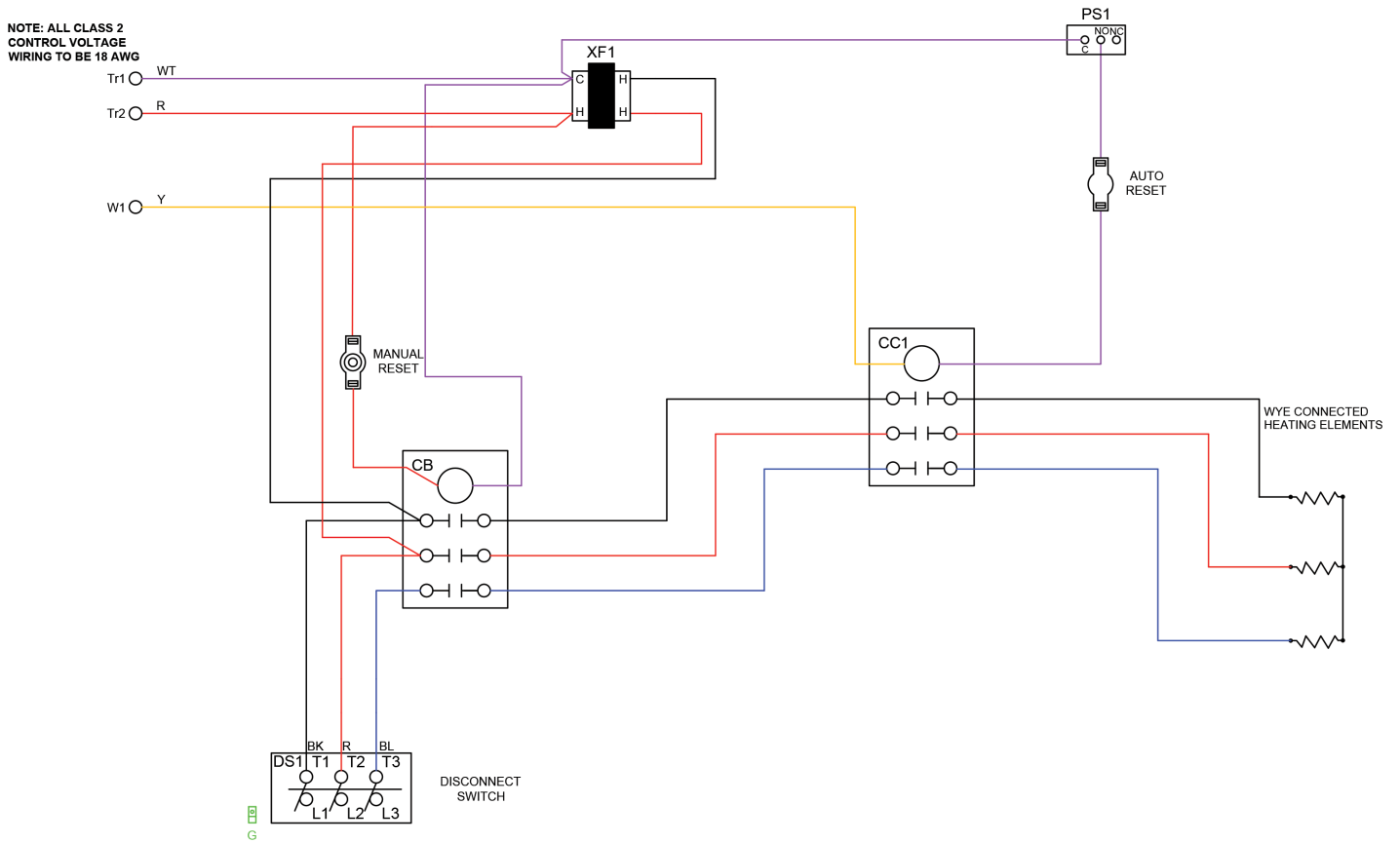

**CAUTION**  
Unit shall be grounded in accordance with N.E.C. Power must be off while servicing.

Wire Color Code					
BK	Black	BL	Blue	BR	Brown
GN	Green	GY	Gray	LT BL	Light Blue
O	Orange	PK	Pink	PR	Purple
R	Red	WT	White	Y	Yellow

LEGEND			
CB	Backup Contactor	PS1	Air Pressure Switch
CC1	Controlling Contactor 1	XF1	Transformer Voltage - 480/24
DS1	Disconnect, Line Voltage - 480/3	- - - -	Field Wired
PS1	Air Pressure Switch	————	Factory Supplied and Wired

- NOTE 1: All class 2 control voltage wiring to be 18 AWG.
- NOTE 2: Plug connection to controller. Wire gauge main = 0, Step = 0, Jumper = 0. Wire gauge varies by configuration. Refer to the unit wiring diagram.
- NOTE 3: Use copper conductors only.
- NOTE 4: 140° F (60° C) for terminals rated less than 100 amps.
- NOTE 5: 167° F (75° C) for terminals rated 100 amps or more.
- NOTE 6: Field control wiring resistance should not exceed 0.75 ohm.

Figure 42: 208/240/408V, Fused Disconnect, Single Phase, 1 Stage EH

NOTE: ALL CLASS 2 CONTROL VOLTAGE WIRING TO BE 18 AWG

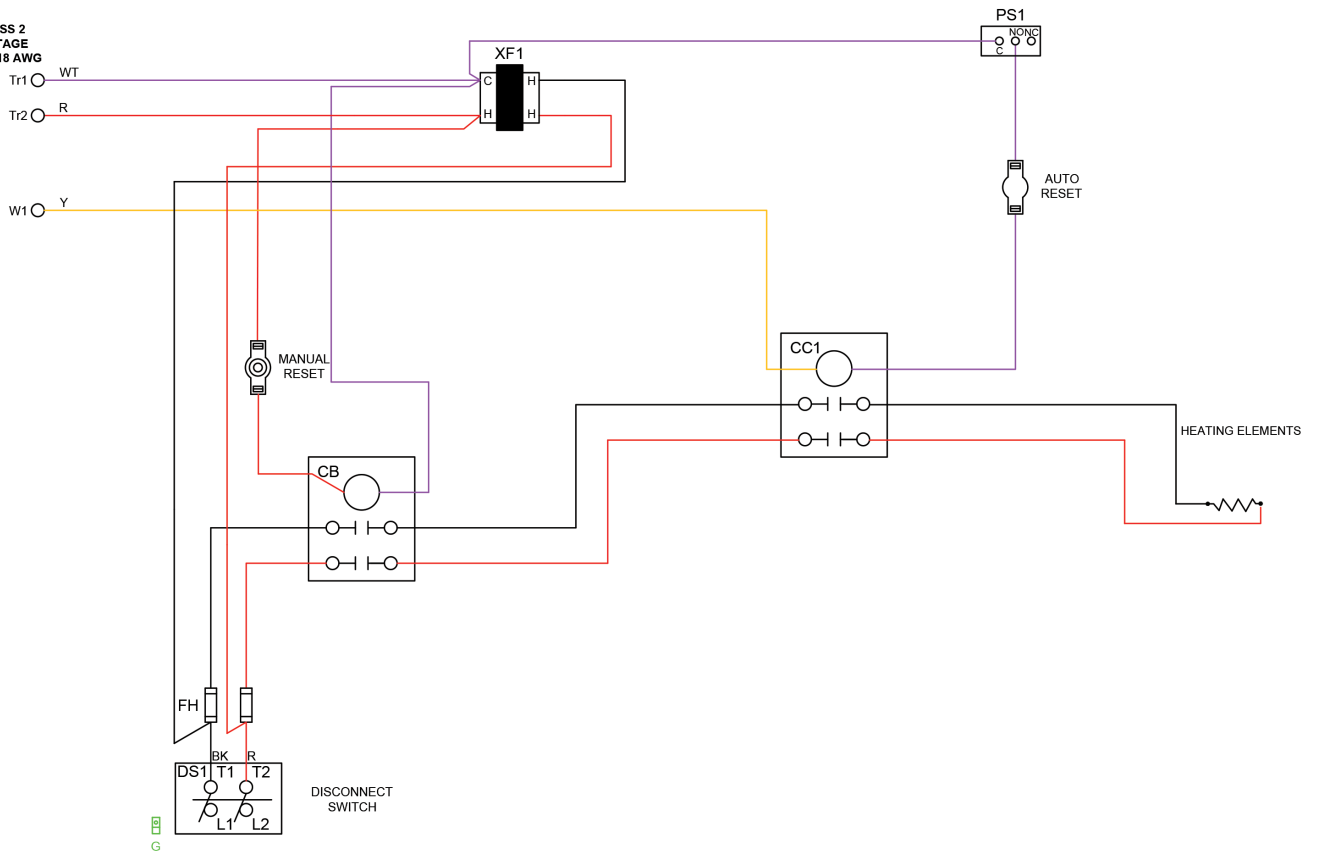

**CAUTION**  
Unit shall be grounded in accordance with N.E.C. Power must be off while servicing.

Wire Color Code					
BK	Black	BL	Blue	BR	Brown
GN	Green	GY	Gray	LT BL	Light Blue
O	Orange	PK	Pink	PR	Purple
R	Red	WT	White	Y	Yellow

LEGEND			
CB	Backup Contactor	PS1	Air Pressure Switch
CC1	Controlling Contactor 1	XF1	Transformer Voltage - 480/24
DS1	Disconnect, Line Voltage - 480/1	- - - -	Field Wired
FH	Heat Fuse, Class CC Fuse, Rated 600 V, 15 amps	_____	Factory Supplied and Wired

NOTE 1: All class 2 control voltage wiring to be 18 AWG.

NOTE 2: Plug connection to controller. Wire gauge main = 0, Step = 0, Jumper = 0. Wire gauge varies by configuration. Refer to the unit wiring diagram.

NOTE 3: Use copper conductors only.

NOTE 4: 140° F (60° C) for terminals rated less than 100 amps.

NOTE 5: 167° F (75° C) for terminals rated 100 amps or more.

NOTE 6: Field control wiring resistance should not exceed 0.75 ohm.

## Electronically Commutated Motors

Figure 43: ECM

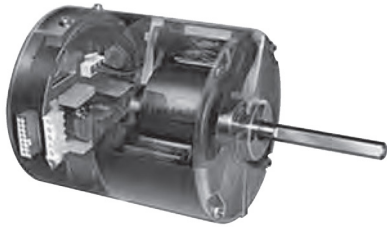

Daikin Applied offers highly efficient electronically commutated motors for the FCI and FVI fan powered terminal units. The ECM is a brushless-DC motor with built in speed and torque controls.

Unlike a conventional induction motor, the ECM regulates itself by automatically changing its torque and speed to maintain a pre-programmed level of constant airflow over a wide range of external static pressures and does so without the use of airflow sensors. The ECM's regulated airflow output remains constant over that same range of static pressure.

For optimum heating, the ECM system can be programmed to deliver just the right level of airflow for both low and high requirements.

### Features and Benefits

#### Ultra-High Efficiency

ECM efficiencies are as high as 82%. At full load the ECM is 20% more efficient than a standard induction motor. At low speed the ECM is over 30% more efficient than a standard induction motor. On constant fan speed, the ECM consumes 60-80 Watts as compared to 400 Watts for the induction motor. The permanent magnet DC design allows it to maintain its efficiency over its wide speed range.

#### Factory Programmed

Programming options for the ECM include: start/stop ramp rates, on/off blower delays, and many other functions all stored in the motor's memory. Even its speed and torque characteristics can be customized to meet specific performance requirements.

#### Self Regulating Constant Airflow

The ECM variable-speed motor can run in a wide range of speeds. The motor can be programmed to deliver constant airflow into a wide range of external static pressures in an air distribution system. This is all accomplished without the use of external sensors.

### ECM Controls

Daikin Applied engineering has carefully integrated the ECM into each terminal blower assembly resulting in a terminal fan that produces a constant CFM over a wide range of operating pressures.

The CFM can be adjusted from the specified minimum CFM to the specified maximum CFM by sending the fan a flow index signal. A fan control interface allows external adjustment of the flow index and provides fan ON/OFF control.

#### ECM Control Interfaces

Daikin Applied offers two fan control interface devices for fan terminals equipped with the ECM.

##### Model ECM-VCU

The visual fan control interface allows local adjustment of the fan CFM and indicates the fan RPM on an illuminated numerical display. The visual control interface may also be used where automation systems only turn the fan ON or OFF.

##### Model ECM-RPM

The automation fan control interface allows an automation system to control fan on/off, fan CFM, and to monitor the fan RPM from the automation console.

Both control interfaces provide a means to monitor fan RPM. This is an important value to record after air balance, and can be used to diagnose system problems.

##### Model ECM-RPM – Remote Adjustment

The ECM-RPM allows industry standard 2-10 VDC controls to adjust and monitor the ECM. These are fractional horsepower air moving motors featuring an internal microprocessor. The design provides exceptional efficiency, performance and motor life. The motor may be factory configured to provide constant mass airflow or constant torque.

The ECM-RPM allows remote adjustment of the output from 0% to 100% of the programmed control range. A lamp on the control continuously flashed out the flow index, so instruments are not required to read the value.

The ECM-RPM version provides low voltage ON/OFF controls by switching the motor's "GO" control when the input signal drops below the 2 volt (4 mA) operating point.

#### Specifications:

	NEC Class II Only
	24 Vac +/- 20%
Power	50/60 Hz
	2 W, 4 VA + 1VA/ Motor
	2-10 VDC – 0-100%
Control Signal	4-20 mA – 0-100%
	ON/OFF Control

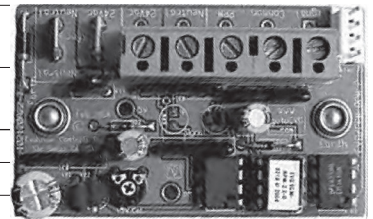

##### Model ECM-VCU – Manual Adjustment

The ECM-VCU control allows accurate manual adjustment and monitoring of fans using the ECM. These are fractional horsepower air moving motors featuring an internal microprocessor. The design provides exceptional efficiency, performance, and motor life. These self-regulating motors may be factory configured so the fan will provide constant mass airflow.

**Operation**

The ECM configured for Vspd operation are factory configured for external torque or airflow adjustment. The configuration data includes the fan manufacturer’s specified adjustment range. A numerical flow index accurately adjusts the fan to the desired torque or airflow. The flow index is a number from 0-100 having a linear relationship to the minimum to maximum torque or airflow range specified by the motor fan.

The ECM-VCU allows local ON/OFF and fan airflow adjustment. Rotating a single screwdriver adjuster changes the variable output signal to the motor from off to full output. While rotating the adjuster, a numerical flow index is locked on the illuminated numerical display. After adjustment, the display shows fan RPM.

The ECM-VCU may also be used where automation systems only turn the fan ON or OFF.

**Specifications:**

	NEC Class II Only
Power	24 Vac +/- 20%
	50/60 Hz
	4 W, 6 VA
Flow Index Adjustment	270° rotation F OFF – 0-100



**Controls**

**DDC Electronic Control Capability**

The majority of controls installed in HVAC systems today are direct digital controls (DDC). Daikin Applied can mount and wire any manufacturer’s control product that fits on our standard control panel, regardless of the brand. Mounting of other manufacturer’s control enclosures or transformer is not available.

In those cases where it is desirable to have the controls field mounted and wired, a basic air terminal without controls can be purchased from Daikin Applied. The basic unit includes a control panel and cover.

In either case where controls are to be factory mounted and wired by Daikin Applied or field installed by the control manufacturer, most types of DDC controllers require a flow sensor. Daikin Applied will provide our multi-quadrant averaging flow sensor which is compatible with all electronic control devices currently on the market.

**Daikin Applied BACnet VAV Actuator**

The Daikin Applied BACnet VAV Actuator provides high performance direct digital control (DDC) of pressure-independent, variable-air-volume zone-level routines. The BACnet VAV Actuator can operate stand-alone or can be networked to perform complex HVAC control, monitoring and energy management functions and is designed to reside on any BACnet control system.

**Figure 44: Daikin Applied BACnet VAV Actuator**



**Features**

- Controller integrated with actuator for ease of installation.
- Automated checkout procedure for ease of startup/ commissioning and troubleshooting.
- PID control of HVAC systems to minimize offset and maintain tighter setpoint control.
- Communicates using BACnet MS/TP protocol for open communications on BACnet MS/TP networks.
- BACnet VAV Actuator requires only 5 VA, an advantage when sizing electrical capacity.
- Suitable for installation in plenum areas.
- Setpoints and control parameters assigned and changed locally or remotely.
- Electrically Erasable Programmable Read Only Memory (EEPROM) used for storing setpoints and control parameters – no battery backup required.
- Return from power failure without operator intervention.
- No calibration required, thereby reducing maintenance costs.

**Applications**

Operating independently, or as part of a BACnet System, the BACnet VAV Actuator can control the following VAV pressure-independent zone applications.

- Single Duct Cooling Only
- Single Duct Cooling and Heating
- Single Duct with Electric Reheat or Baseboard Radiation
- Single Duct with Hot Water Reheat
- Series Fan with Electric Reheat
- Series Fan with Hot Water Reheat
- Parallel Fan with Electric Reheat
- Parallel Fan with Hot Water Reheat

# System Considerations

## UL 1995 and Daikin Applied Electric Heat Design Criteria

All Daikin Applied Air Terminal Units with electric heat are built to UL 1995 standards. Intertek/ETL is the listing agency we have chosen to enforce UL 1995 requirements. The agency is primarily concerned with safety of the product, especially in regards to fire and electric shock hazards.

The following items are governed by the listing agency to ensure safety:

- Sheet metal thickness and corrosion resistance
- All internal components must be either UL listed or recognized
- Internal wiring and electrical spacings of live uninsulated parts in regard to voltage ratings
- Internal control enclosure and electrical component temperatures
- Primary and secondary temperature limit ratings
- Airflow and fan interlock requirements
- Discharge and duct temperature rise. This indirectly influences our minimum airflow requirements
- Maximum kW for a given unit size based upon 17 kW/sq ft and available airflow
- Duct insulation and adhesive temperature and flammability ratings.

All Air Terminal Unit models must be tested before the ETL label is issued to our products. The agency representative chooses at least 2 samples of each model to be tested, usually the largest and smallest units with the maximum kW allowable for each size. A specially designed duct with temperature sensing thermocouples is attached to the discharge of the heater to measure temperature rise under various normal and abnormal operating conditions. All of our units with Electric Heat are designed for zero clearance to combustible materials. This limits our maximum discharge temperature to 200°F and the duct surface temperature to 197°F (Section 45.9 of UL 1995, 3rd Edition).

To meet the above temperature rise, testing has shown that the primary limit control (auto reset thermal cutout) should be rated at 120°F. The spacing between the return bend of the element and the primary limit control, as well as general placement, is determined by this test. As the airflow begins to drop, glowing of the return bends send radiant energy to the cutout, adding to the air temperature sensed by this device. The cutout is assured of tripping before the maximum temperature is achieved, by breaking the operating or safety contactors and de-energizing the heating elements.

In the event of primary limit control failure, a backup system is employed that is completely independent of the primary limit control or controlled switching device (operating contactor or safety contactor). This secondary limit control system utilizes a manual reset thermal cutout that controls a backup contactor

wired in series with the heating elements. The requirements and placement of the manual reset cutout is also determined by testing to limit the duct temperature to a maximum of 212°F (Section 47.2).

To meet the above temperature rise, testing has shown that the secondary limit control (manual reset thermal cutout) should be rated at 160°F maximum. The spacing between the return bend of the element and the primary limit control, as well as general placement, is determined by this test. The cutout is assured of tripping before the maximum temperature is achieved by breaking the backup contactor and de-energizing the heating elements. All tests are conducted under specific duct static pressure conditions.

In addition to temperature rise, a method of fan or airflow interlock system must be provided to prevent heater operation when no airflow is present. Section 26.11 of UL 1995 describes its function.

All single duct units with electric heat utilize an airflow-sensing switch that measures supply airflow at the discharge side near the air valve. It must read a total pressure (static + velocity) of at least 0.07" of positive pressure to operate. On Dust-Tight applications, the negative port of this switch must be vented outside of the control enclosure to prevent reading pressure buildup within the enclosure.

All fan powered units with electric heat have a fan interlocking relay that will not allow the heater to energize until power to the fan motor is confirmed. The control transformer is also wired in series with the motor fuse, to prevent the heater from energizing by breaking all control voltage to the heater when the fuse opens. The optional airflow-sensing switch can be specified as a secondary device. It requires a probe placed near the blower discharge to sense positive pressure. FC units also require venting of the negative port of the airflow switch to the negative pressure of the blower plenum to assure sufficient differential pressure. The fan interlock relay remains operational when the optional airflow switch is chosen.

Units with electric heat should have a minimum airflow of 70 CFM per kW. Also, a maximum leaving air temperature of 115°F should be observed to prevent premature heater coil failure. The temperature rise is a function of kW and airflow:  $TR = (kW \times 3413) / (CFM \times 1.085)$ . The entering air temperature will determine the leaving air temperature:  $Entering\ Air\ Temperature + Temperature\ Rise = Leaving\ Air\ Temperature$ . In this case, we want to limit the leaving air temperature to 115°F maximum. Ideally, per an ASHRAE Article published in a 1979 handbook, the leaving air temperature should be around 15°F above the room set point to prevent air stratification. Our catalog recommends no more than 20° F above the set point.

How does this all relate to Daikin Applied design? The primary cutout limit was selected to be 120°F to meet the Primary Limit Control test.

These cutouts are generally accurate within 5°F. To prevent nuisance tripping of the cutout, and eventual fatigue failure, the leaving air temperature must never exceed 115°F. Also, in the event that either the auto reset or airflow switch trips due to sudden loss of airflow or improperly programmed DDC control systems that allow the heater to function during recalibration,

stored heat will build up within the heater, allowing the temperature to continue to rise above the auto reset set point. To prevent unnecessary tripping of the manual reset, the setting of 160°F provides a safe temperature spread and prevents this from occurring. At the same time, it prevents duct temperatures above 212°F from being reached in the event that there is total failure of the primary limit system.

The 70 CFM/kW rule assumes that the inlet air temperature does not exceed 70°F. This temperature is usually less for single duct units (55°F typical). If it is known that the inlet temperature will always be below 70°F, calculation of the Catalog program can be used to determine the outlet temperature per the formulas above. As an example, a 5 kW heater will need at least 350 CFM if the inlet air temperature is 70°F, but this same heater can go as low as 265 CFM if the inlet air temperature is 55°F. Since the ideal leaving air temperature is 95°F or less, it is recommended not to go below 70 CFM per kW.

Fan powered units use a mix of primary air (about 55°F) and plenum air (about 75°F). This mix will usually average out to about 70°F or less unless the primary air is set to zero. This further reinforces the need to limit the minimum airflow setting to 70 CFM per kW.

## Sound Path Attenuation Assumptions

The current AHRI standard for NC calculation is AHRI 885-08

Table 86: AHRI-885-08 Radiated Sound Path Assumptions

Assumptions	Octave Band					
	2	3	4	5	6	7
Environmental Effect	2	1	0	0	0	0
Ceiling/Space Effect*	16	18	20	26	31	36
Total dB Reduction	18	19	20	26	31	36

NOTE: Attenuation assumptions are based upon factors located in the AHRI Standard AHRI-885-08

**Parameters:**

1. Mineral fiber ceiling tile, 5/8" thick (35 lb/3 ft density)
2. The plenum space is at least 3 ft deep and either wide (>30 ft) or insulated

\* Combined effect including absorption of the ceiling tile, plenum absorption and room absorption.

This is new to AHRI-885-08; AHRI-885-90 had separate lines for these absorptions.

## AHRI-885-08, Appendix E defines “Small” for applications less than 300 CFM

Table 87: AHRI-885-08 Discharge Sound Path Assumptions, Small

Assumptions	Octave Band					
	2	3	4	5	6	7
Environmental Effect	2	1	0	0	0	0
Duct Lining	2	6	12	25	29	18
End Reflection	9	5	2	0	0	0
Flex Duct	6	10	18	20	21	12
Space Effect	5	6	7	8	9	10
Power Split	0	0	0	0	0	0
Total dB Reduction	24	28	39	53	59	40

NOTE: Attenuation assumptions are based upon factors located in the AHRI Standard AHRI-885-08

**Parameters:**

1. Fiberglass duct lining is 1" thick, 8x8 duct length is 5 feet
2. Flex duct is 8" in diameter and 5 feet in length for run to diffuser
3. Flex duct has vinyl core
4. Room size is 2400 3 ft
5. Unit is located 5 feet from measurement point
6. Sound power split: attenuation credit based on unit feeding one outlet (10 log (# outlets=1))

## AHRI-885-08, Appendix E defines “Medium” for applications from 300-700 CFM

Table 88: AHRI-885-08 Discharge Sound Path Assumptions, Medium

Assumptions	Octave Band					
	2	3	4	5	6	7
Environmental Effect	2	1	0	0	0	0
Duct Lining	2	4	10	20	20	14
End Reflection	9	5	2	0	0	0
Flex Duct	6	10	18	20	21	12
Space Effect	5	6	7	8	9	10
Power Split	3	3	3	3	3	3
Total dB Reduction	27	29	40	51	53	39

NOTE: Attenuation assumptions are based upon factors located in the AHRI Standard AHRI-885-08

**Parameters:**

1. Fiberglass duct lining is 1" thick, 12x12 duct length is 5 feet
2. Flex duct is 8" in diameter and 5 feet in length for run to diffuser
3. Flex duct has vinyl core
4. Room size is 2400 3 ft
5. Unit is located 5 feet from measurement point
6. Sound power split: attenuation credit based on unit feeding one outlet (10 log [# outlets=2]).

## AHRI-885-08, Appendix E defines “Large” for applications 700 CFM and greater

**Table 89: AHRI-885-08 Discharge Sound Path Assumptions, Large**

Assumptions	Octave Band					
	2	3	4	5	6	7
Environmental Effect	2	1	0	0	0	0
Duct Lining	2	3	9	18	17	12
End Reflection	9	5	2	0	0	0
Flex Duct	6	10	18	20	21	12
Space Effect	5	6	7	8	9	10
Power Split	5	5	5	5	5	5
Total dB Reduction	29	30	41	51	52	39

**NOTE:** Attenuation assumptions are based upon factors located in the AHRI Standard AHRI-885-08

### Parameters:

1. Fiberglass duct lining is 1" thick, 15×15 duct length is 5 feet
2. Flex duct is 8" in diameter and 5 feet in length for run to diffuser
3. Flex duct has vinyl core
4. Room size is 2400 3 ft
5. Unit is located 5 feet from measurement point
6. Sound power split: attenuation credit based on unit feeding one outlet ( $10 \log [\# \text{ outlets}=3]$ ).

## System Design and Noise Generation

The central system equipment and distribution ductwork must be properly designed if the air terminal units are to operate correctly. Noise generated at the central system travels through the duct system to the individual zones and can be objectionable when it is sufficient to ‘break out’ of the duct system or is carried through the duct system to ‘discharge’ into the occupied zone.

The most common source of objectionable noise emanating from VAV systems arises from high static pressure in primary (upstream of the terminal unit) duct systems. These pressures have a two-fold effect of increasing the central system sound levels and of causing the terminal units to operate noisily. When the pressure is too high, the primary air damper must close to compensate. The air flowing past the damper must do so at a relatively high pressure drop creating objectionable noise levels.

This is seen quite commonly in VAV systems when the highest inlet static pressure in a distribution duct is used as the default condition for all terminal units served by the trunk duct. The result is over sizing of the upstream VAV terminal units. The result is additional system cost, excessive noise, and inefficient operation of the terminal units. To avoid this condition, the designer would be better suited to provide a balancing damper ahead of the upstream branch ducts serving these terminal units, reducing the inlet pressure at each unit.

System noise is also commonly generated by improper duct design or installation. Particular care should be taken in the excessive and improper use of flex duct as it is more susceptible to break out noise and can cause noisy airflow equipment operation when installed in a ‘kinked’ fashion. Avoid using ‘bullhead’ tees and tight elbows before and after terminal units and discharge devices.

In order to ensure proper VAV terminal selection, the system sound pressure levels should be determined. These levels can be used in accordance with AHRI Standard 885 to determine the maximum sound power levels acceptable for each terminal unit. Design engineers should familiarize themselves with the standard and perform an acoustical analysis of each critical path within the system. Standard 885 provides the methodology and data to perform such an analysis for most common applications. Critical applications may require consultation with an acoustical consultant.

# Engineering Specifications

## AIR TERMINAL UNITS

### PART 1--GENERAL

#### 1.01 SUBMITTALS

##### A. PRODUCT DATA

1. Specific airflows and electrical characteristics shall be indicated on the equipment schedules
2. Manufacturer's Installation Instructions.
3. Fan curve data shall be provided in a submittal.
4. Provide literature that indicates dimensions, weights, capacities, ratings, fan performance, and electrical characteristics and connection requirements.
5. All NC values shall be calculated per AHRI Standard 885-08. Terminal units shall be either ETL® or UL® listed as a complete assembly. Terminal electrical components, including actuators and low voltage controls shall be UL® listed. All electrical components including both line voltage and low voltage shall be mounted in a metal control enclosure. Units shall have a single point field wiring connection. Units shall be manufactured and wired per UL-1995 and in accordance with the National Electric Code.
6. Certification- Air terminals shall satisfy (AHRI) Standard 880-08.

B. Shop Drawings: Indicate unit dimensions, weight loading, construction details, field connection details, equipment schedule.

### PART 2--PRODUCTS

#### 2.01 GENERAL DESCRIPTION

A. The air terminals shall be constructed of zinc coated steel. Units shall have a universal control-mounting panel constructed of 20-gauge steel. The primary control damper shall be a single blade, round damper operating within a 20-gauge round tube. The terminal unit discharge shall allow for a rectangular flanged duct connection. Units shall have a universal control-mounting panel constructed of 20-gauge steel. Panel shall include stand-offs to allow controls to be mounted without penetrating the terminal casing. Low pressure downstream casing shall be 22-gauge.

B. Primary inlet valve assembly shall have a seamless butt weld on round inlet tube to minimize leakage and prevent the damper from binding on overlapping seam welds. Inlet tubes with overlapping welds or non-continuous, skipped welds are not acceptable. Damper shaft shall rotate in a self-lubricating, long life, low friction Thermoplastic bearing. Damper shaft end shall include a damper position indicator.

C. Damper tube shall be free of obstructions including damper stops to allow the free rotation of the damper. Mechanical damper stops located in the inlet tube are not acceptable. A flexible gasket mounted in the damper blade without adhesives shall provide damper seal. Damper gasket shall include slit partitioning around the perimeter to prevent damper noise at low flows near full close off. Damper gaskets without perimeter slit partitioning are not acceptable. Damper shall be a double thickness of 24-gauge steel and leakage through the damper assembly shall be less than 1% of maximum CFM at 3" static pressure.

D. Inlet air valve shall have structural beads machine formed into the tube. One external bead shall be provided for the attachment of flexible duct. Inlet air valve flow sensor shall be multipoint quadrant averaging with flow sampling of both velocity pressure and flow differential pressure from four quadrants, and shall contain two control ports and two accessory ports. Flow sensors sampling only velocity pressure in all four quadrants are not acceptable. Sensors reading differential pressure with less than 8 measuring points are not acceptable. All piping connections to the flow sensor must be made with external ports that extend through damper tube. Units with piping connections made in the primary air stream are not acceptable. Flow sensors with plastic piping connections of any kind are not acceptable.

E. At an inlet velocity of 2000 fpm, the differential static pressure required to operate any terminal size shall not exceed 0.14 in.w.g. for the basic terminal.

F. Standard profile inlet sizes 6 through 16 inch shall have a round inlet for field duct connection.

G. MQTH15 unit sizes 20 and 24 shall have a rectangular blade damper assembly.

H. Units shall be internally insulated with 1/2" thick (for TH and FCL) or 1" thick (for FCI and FVI), 1.5 lbs/ft<sup>3</sup> dual density glass fiber, coated to prevent air flow erosion to 6000 fpm surface velocity. However, if an upgraded liner is selected, it will replace the standard glass fiber. In that case, please reference the Upgrade Liner section for the appropriate specification insulation to comply with UL 181 and NFPA 90A.

I. Sound performance shall be ARI certified. Each individual terminal unit shall bear an ARI label. The specified NC for the radiated and discharge path attenuation function shall be based upon the calculations found in current ARI Terminal Unit Application Standard 885-2008E (data submitted per the previous ARI Standard 885-90 and 885-98 are not acceptable).

J. MQFCI6, MQFCL6, and MQFVI5 units shall have a bottom fan access panel and a separate bottom primary inlet access panel. Single bottom access panels are not acceptable.

K. All boxes shall be tagged with addresses, min/max flows and mounting locations per the room schedule to match mechanical prints.



## 2.02 HANGER BRACKETS

A. [OPTIONAL] Hanger brackets shall be shipped loose for field installation. Hanger brackets shall be designed to accept treaded rod up to 5/16" diameter.

## 2.03 FILTER RACK OPTION

A. [OPTIONAL] FC and FVI unit may include filter rack in the induced air inlet and shipped from the manufacturer with a 1" thick construction filter.

## 2.04 FAN MOTOR

A. ECM Fan shall be a forward curve, dynamically balanced with a direct drive motor. Units shall include energy efficient, General Electric electronically commutated motors model ECM 2.3. Motors shall be 60 cycle, (120 OR 277) volts. The motor shall be single speed manufactured specifically to meet the torque requirements for each size terminal.

## 2.05 FAN MOTOR CONTROL

A. [OPTIONAL] Units shall include the model ECM-VCU controller that allows for manual motor adjustment. Controller shall have a 4 digit LED display indicating motor RPM. The display shall also show a flow index.

B. [OPTIONAL] Units shall include the model ECM-RPM controller that allows for remote adjustment of the motor. Controller shall accept either a 2-10 Vdc signal or 4-20 to turn off the fan.

## 2.06 SUPPLY FAN

A. For FC and FV units, fan shall be a forward curve, dynamically balanced with a direct drive motor.

## 2.07 LINER UPGRADES

A. [OPTIONAL] Air Terminal shall be internally insulated with 1" thick, 1.5 lbs/ft<sup>3</sup> [dual] fiber free liner, rated to prevent air flow erosion to 6000 fpm surface velocity. Insulation to comply with UL 181 and NFPA 255 (25/50). Material shall be chemically resistant to most hydrocarbon based solvents. Material shall not support mold growth or demonstrated degradation while subject to air erosion when tested in accordance to UL 181 and UMC 10-1.2.

B. [OPTIONAL] Foil Face Linear Air Terminal shall be internally insulated with (1/2" thick, 1.5 lbs/ft<sup>3</sup> OR 1" thick, 4 lb/ft<sup>3</sup>) dual density fibrous glass with foil face, rated to prevent air flow erosion to 6000 fpm surface velocity. Insulation to comply with UL 1821 and NFPA 90A. All edges shall be encased within metal strips welded to the casing. Liner shall secure insulation into terminal unit. Liners made of Mylar, Tedlar, Silane, or woven fiberglass cloths not acceptable.

## 2.08 HEATING OPTION

### A. [OPTIONAL] ELECTRIC HEAT

1. All terminals shall be shipped as a single unit requiring no field assembly. Accessories including hot water coils and electric heaters shall be factory mounted.
2. Electric Reheat Coils are to be factory mounted on the outlet end of the Air Terminal with the sizes and with kilowatts, operating and control voltages, steps and accessories as outlined in the plans and specifications. The heaters shall be ETL<sup>®</sup> listed for zero clearance, tested in accordance with UL<sup>®</sup> Standard 1996 and the National Electric Code (NEC). Heater casings shall be constructed of heavy-duty zinc-coated steel. Element wire shall be high grade nichrome alloy de-rated to 50 watts per square inch density. Element wire shall be supported by moisture resistant steatite ceramics. Ceramics to be enclosed in reinforcement brackets spaced across the heater element rack at 2" to 4" intervals. Controls shall be contained in a NEMA 1 control cabinet with a hinged, latching door. A permanent wiring diagram shall be affixed to the inside of the control cabinet door for field reference. The heating element rack shall be recessed 1" into the duct to assure adequate air temperature readings for proper operation of safety switches.
3. Each Electric Duct Heater shall be shipped with a ETL<sup>®</sup> label certifying that it meets or exceeds the safety requirements of Standard 1996. Each heater will have an automatic primary over-temperature limit switch, a manual reset over-temperature limit switch, air static or fan relay type air proving switch and fusing if the heater exceeds 48 amps as required by UL<sup>®</sup>. A terminal block for line and control voltage shall be provided for simplified field wiring. A P. E. switch or contactor per step shall be provided for each stage of heat.

### B. [OPTIONAL] Hot Water Coil

1. Hot Water Coils are to be factory mounted to the discharge outlet of the terminal. Hot water coils shall be enclosed in a minimum 20-gauge coated steel casing allowing attachment to metal ductwork with a slip and drive connection. Fins shall be rippled and sine wave type, constructed from heavy gauge aluminum, and mechanically bonded to the tubes. Tubes shall be copper with a minimum wall thickness is 0.016" with male sweat header connections.
2. Coils shall be leak tested to 300 psi with minimum burst of 2000 psi at ambient temperature. Coil performance data shall be rated and presented in accordance with AHRI standard 410. Coils must be ARI rated, certified and include an AHRI label. Coils that are not AHRI rated, certified or labeled AHRI are not acceptable.

# COMPLETE HVAC SYSTEM SOLUTIONS

SELF-CONTAINED | ROOFTOPS | COILS | CONDENSING UNITS  
AIR HANDLERS | WATER-COOLED CHILLERS | AIR-COOLED CHILLERS  
MODULAR CENTRAL PLANTS | CONNECTED BUILDING CONTROLS  
UNIT HEATERS | FAN COILS | AIR PURIFIERS | WATER SOURCE HEAT PUMPS  
VARIABLE AIR VOLUME UNITS | UNIT VENTILATORS



13600 INDUSTRIAL PARK BLVD. | MINNEAPOLIS, MN 55441  
1-800-432-1342 | 763-553-5330

LEARN MORE AT  
**DAIKINAPPLIED.COM**