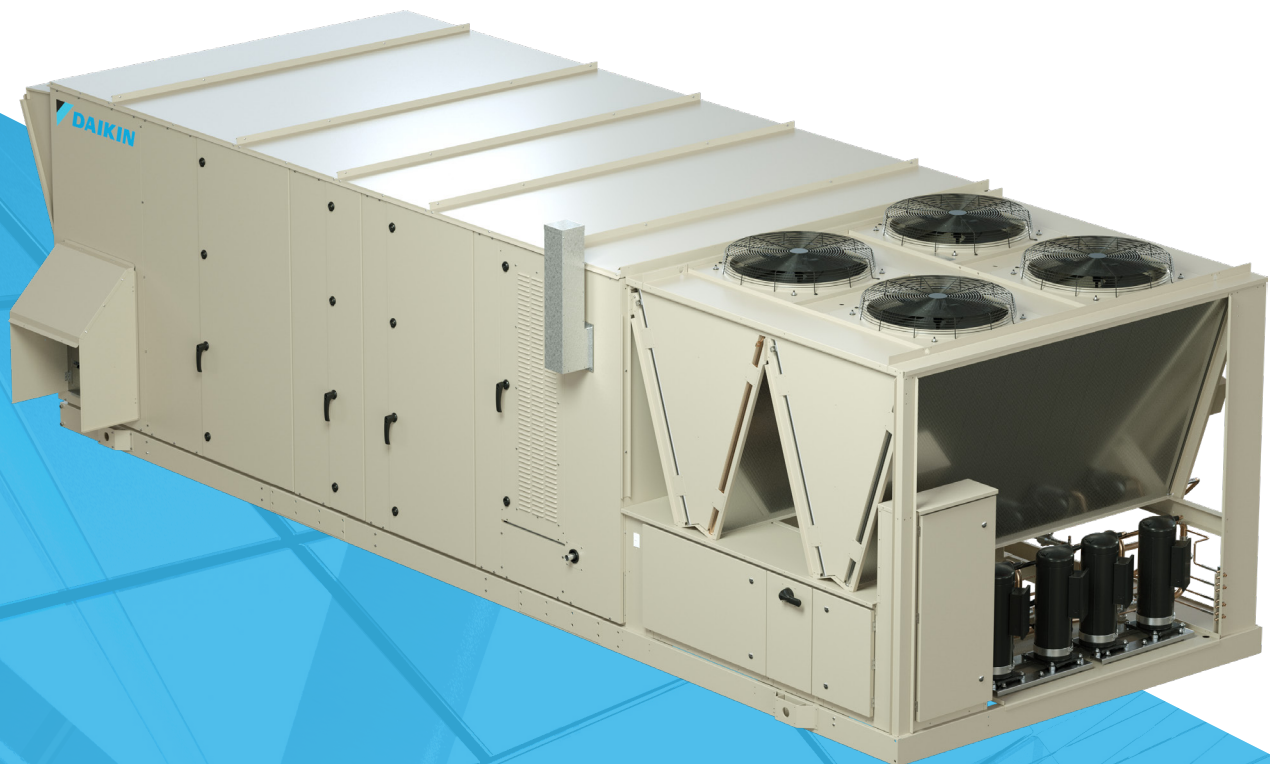




# REBEL APPLIED® PACKAGED ROOFTOP



- HEATING AND COOLING
- R-32 REFRIGERANT
- MODELS: DPSA, DAHA, DHSA
- 20 TO 160 TONS

# Table of Contents

<b>Introduction</b> . . . . .	<b>3</b>	<b>Unit Operation</b> . . . . .	<b>76</b>
Nameplate Information . . . . .	3	Preparing Unit for Operation . . . . .	76
Hazardous Information Messages . . . . .	3	<b>Start-Up, Checks, and Tests</b> . . . . .	<b>87</b>
Unit Labels . . . . .	5	ECM Motor . . . . .	96
Condenser and Compressor Piping . . . . .	15	MicroTech® Remote User Interface . . . . .	100
<b>Installation</b> . . . . .	<b>28</b>	<b>R-32 Guidelines</b> . . . . .	<b>103</b>
Receiving and Handling . . . . .	28	<b>Unit Maintenance</b> . . . . .	<b>112</b>
Compliance Statements . . . . .	28	Servicing Control Panel Components . . . . .	112
Unit Clearances . . . . .	28	Example Wiring Diagram . . . . .	113
Ventilation Clearance . . . . .	31	Planned Maintenance . . . . .	127
Roof Curb Assembly and Installation . . . . .	32	Daikin Applied Electric Heater Modules . . . . .	128
Wiring With Full Perimeter Curbs . . . . .	35	Electric Heater Step Controller . . . . .	131
Post and Rail Mounting . . . . .	37	Step Controller Troubleshooting . . . . .	133
Lifting Guidance . . . . .	37	<b>Tubular Gas Heater</b> . . . . .	<b>138</b>
Transit and Temporary Storage . . . . .	39	Unit Location and Clearances . . . . .	140
Shipping Splits . . . . .	40	Ventilation and Flue Pipe Requirements . . . . .	141
Unit Piping . . . . .	46	Field Gas Piping . . . . .	154
Panel Piping Penetrations . . . . .	54	Burner and Gas Manifold Pressure Adjustment Instructions . . . . .	160
Damper Assemblies . . . . .	59	Maxitrol EXA Star Controller . . . . .	161
HEPA Frame, Filter, and Prefilter Installation . . . . .	61	Sequences of Operation . . . . .	163
Installing Ductwork . . . . .	65	Operations . . . . .	173
Installing Duct Pressure Taps . . . . .	65	Furnace Wiring Diagrams . . . . .	175
Indoor Air Quality (IAQ) Installations . . . . .	66	Maxitrol EXA Star Valve Calibration . . . . .	191
Fan Block-off Plates . . . . .	68	<b>Warranty</b> . . . . .	<b>193</b>
Top Discharge . . . . .	69	Rooftop Equipment Warranty Registration Form . . . . .	193
Side Discharge . . . . .	69	Daikin Applied Limited Warranty . . . . .	194
<b>Unit Wiring</b> . . . . .	<b>71</b>	Warranty Registration Form . . . . .	195
Field Power Wiring . . . . .	71		
Field Control Wiring . . . . .	73		
Field Output Signals . . . . .	73		

©2026 Daikin Applied, Minneapolis, MN. All rights reserved throughout the world. This document contains the most current product information as of this printing. Daikin Applied Americas Inc. has the right to change the information, design, and construction of the product represented within the document without prior notice. For the most up-to-date product information, please go to [www.DaikinApplied.com](http://www.DaikinApplied.com).

™® Rebel Applied, MicroTech, and Daikin Applied are trademarks or registered trademarks of Daikin Applied Americas Inc. The following are trademarks or registered trademarks of their respective companies: BACnet from American Society of Heating, Refrigerating and Air-Conditioning Engineers, Inc.; Echelon, LonWorks, LonMark, and LonTalk from Echelon Corporation; Modbus from Schneider Electric; and Windows from Microsoft Corporation, Intertek from Intertek Group PLC.

# Introduction

This manual provides installation information about the Rebel Applied rooftop unit. In addition to an overall description of the unit, it includes mechanical and electrical installation and start-up procedures. For operations and/or maintenance procedures, see OM 1373.

**Table 1: Rebel Applied Rooftop Unit Literature**

Product	Manual Title	Manual Number
Rebel Applied	Unit Operation	OM 1373
	A2L Mitigation Board	IM 1365
	Forced Draft Furnace	IM 684
	Modbus Integration	ED 19133
	BACnet and Lon Protocol Information	ED 19117
	Non-Daikin Applied	See vendor manuals

## Nameplate Information

### Unit Nameplate

The unit nameplate is located on the outside lower right corner on the main control box door. It includes the unit model number, serial number, unit part number, electrical characteristics, and refrigerant charge. There is also a duplicate inside the main control box door.

### Compressor Nameplate

On units that utilize the tandem or trio compressor design, each compressor includes an individual nameplate.

### Electric Heater Nameplate

On units that include electric heat, the cabinet electric heater nameplate is located next to the electric heater access door. The electric heater rating plate is included on the electric heater; this includes the electric heater model number.

### Fusing

The use of properly sized time delay fuses, in accordance with nameplate data, is permitted for this unit.

## Hazardous Information Messages

### DANGER

Danger indicates a hazardous situation, which will result in death or serious injury if not avoided.

### WARNING

Warning indicates a potentially hazardous situations, which can result in property damage, personal injury, or death if not avoided.

### CAUTION

Caution indicates a potentially hazardous situations, which can result in minor injury or equipment damage if not avoided.

### NOTICE

Notice indicates practices not related to physical injury.

**NOTE:** Indicates important details or clarifying statements for information presented.

## Packaged Gas Heater Module

ANSI Z83.8/CSA 2.6

### WARNING

#### Risque D'Incendie ou D'Explosion

Le non respect des mises en garde pourrait entraîner des blessures graves, la mort, ou des pertes matérielles. Prendre soin de lire et de comprendre les instructions d'installation, de fonctionnement et d'entretien contenues dans ce guide. Une installation, un réglage, une modification, une réparation ou un entretien inapproprié peut entraîner des blessures graves, la mort, ou des pertes matérielles.

- Ne pas entreposer ni utiliser d'essence ou autres vapeurs ou liquides inflammables à proximité de cet appareil ou de tout autre appareil.
- **QUE FAIRE SI VOUS SENTEZ UNE ODEUR DE GAZ**
- Ne tentez pas d'allumer un appareil.
- Ne touchez pas à un interrupteur; n'utilisez pas de téléphone dans l'édifice ou vous trouvez.
- Sortez de l'édifice immédiatement.
- Appelez immédiatement le fournisseur de gaz à partir d'un téléphone à l'extérieur de l'édifice. Suivez les instructions du fournisseur de gaz.
- Si vous ne pouvez joindre le fournisseur de gaz, appelez les pompiers.
  - L'installation et les réparations doivent être confiées à un installateur qualifié ou au fournisseur de gaz.

### WARNING

#### Fire or Explosion Hazard

LOCKOUT/TAGOUT all power sources prior to installing the gas furnace. Failure to follow warnings exactly could result in serious injury, death, or property damage. Be sure to read and understand the installation, operation, and service instructions within this manual. Improper installation, adjustments, alterations, service, or maintenance can cause serious injury, death, or property damage.

- Do not store or use gasoline or other flammable vapors or liquids in the vicinity of this appliance.
- **What to do if you smell gas**
- Do not try to light any product that is fueled by or contains an open flame.
- Do not touch any electrical switch.
- Do not use any telephone in the building.
- Leave the building immediately.
- Immediately call the gas supplier from a remote telephone and follow the gas supplier's instructions.
- If you cannot reach the gas supplier, call the local fire department or 911.
  - Installation and service must be performed by a qualified installer, service agency, or gas supplier.

## R-32 Refrigerant Information

### WARNING



This unit contains R-32, a class A2L refrigerant that is flammable. This unit should only be installed, serviced, repaired, and disposed of by qualified personnel licensed or certified in their jurisdiction to work with R-32 refrigerant. Installation and maintenance must be done in accordance with this manual. Improper handling of this equipment can cause equipment damage or personal injury.

Be aware that R-32 refrigerant may not contain an odor. Place in a well ventilated area to prevent accumulation of refrigerant. Excessive refrigerant leaks, in the event of an accident in a closed ambient space, can lead to oxygen deficiency.

Do not pierce or burn this unit.

Never use an open flame during service or repair. Never store in a room with continuously operating ignition sources (for example: open flames, an operating gas appliance, or an operating electric heater), where there is ignitable dust suspension in the air, or where volatile flammables such as thinner or gasoline are handled.

Only use pipes, nuts, and tools intended for exclusive use with R-32 refrigerant in compliance with national codes (ASHRAE 15 or IRC).

Do not mix air or gas other than R-32 in the refrigerant system. If air enters the refrigerant system, an excessively high pressure results, which may cause equipment damage or injury.

For more information, consult "R-32 Guidelines" on page 103.

### WARNING

When moving flammable A2L refrigerant to/from the unit from an auxiliary tank, a grounding strap must be used. An electrical charge builds when halocarbon refrigerant travels in a rubber hose. A grounding strap must be used between the auxiliary refrigerant tank and the unit's end sheet (earth ground), which will safely take the charge to the ground. A fire risk could occur if this procedure is not followed.

## Unit Labels

Pictogram warning and informational labels may be present on the unit. Consult the table below for reference.








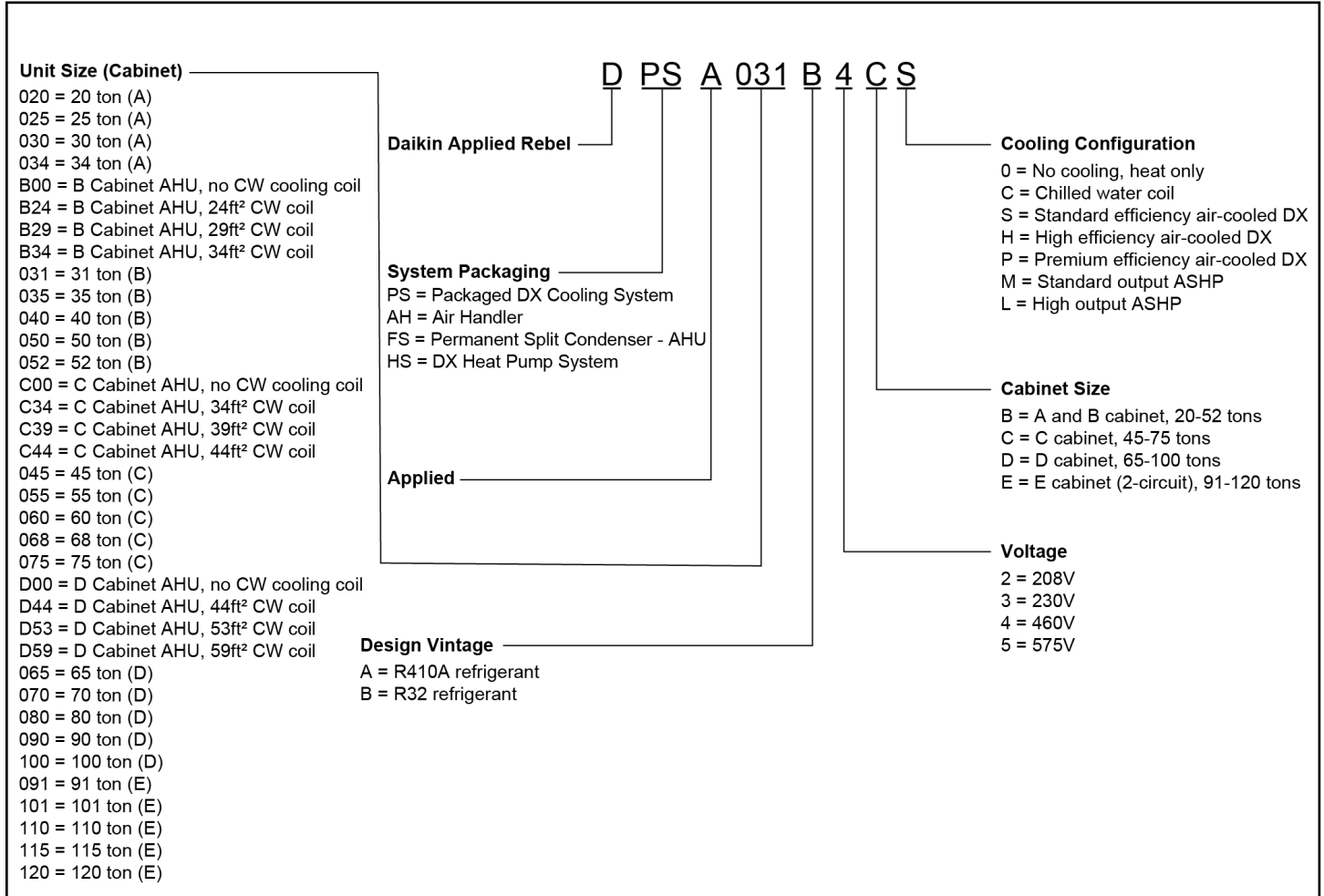
Label	Description
 <p>Refrigerant class per ISO 817</p>	<p><b>WARNING - flammable refrigerant present</b></p>
	<p>Read the technical manual for service instructions</p>
	<p>WARNING - A2L low-burning velocity refrigerant present</p>
	<p>Pressurized medium present</p>
	<p>Ultraviolet (UV) radiation present</p>
	<p>Read the technical manual for instructions</p>
	<p>WARNING - flammable refrigerant present</p>

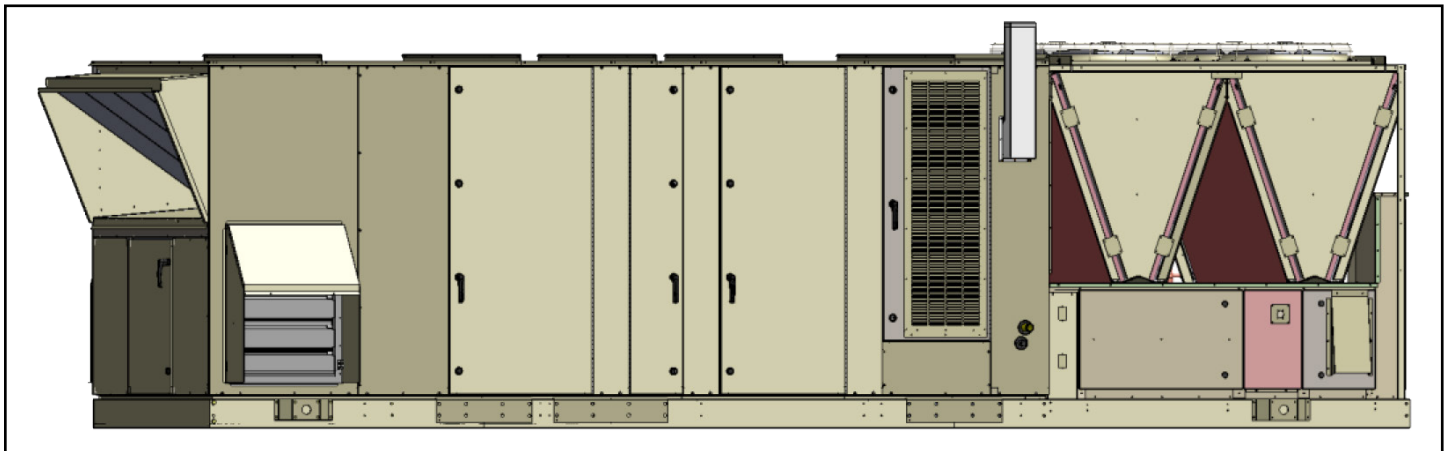
Figure 1: Nomenclature



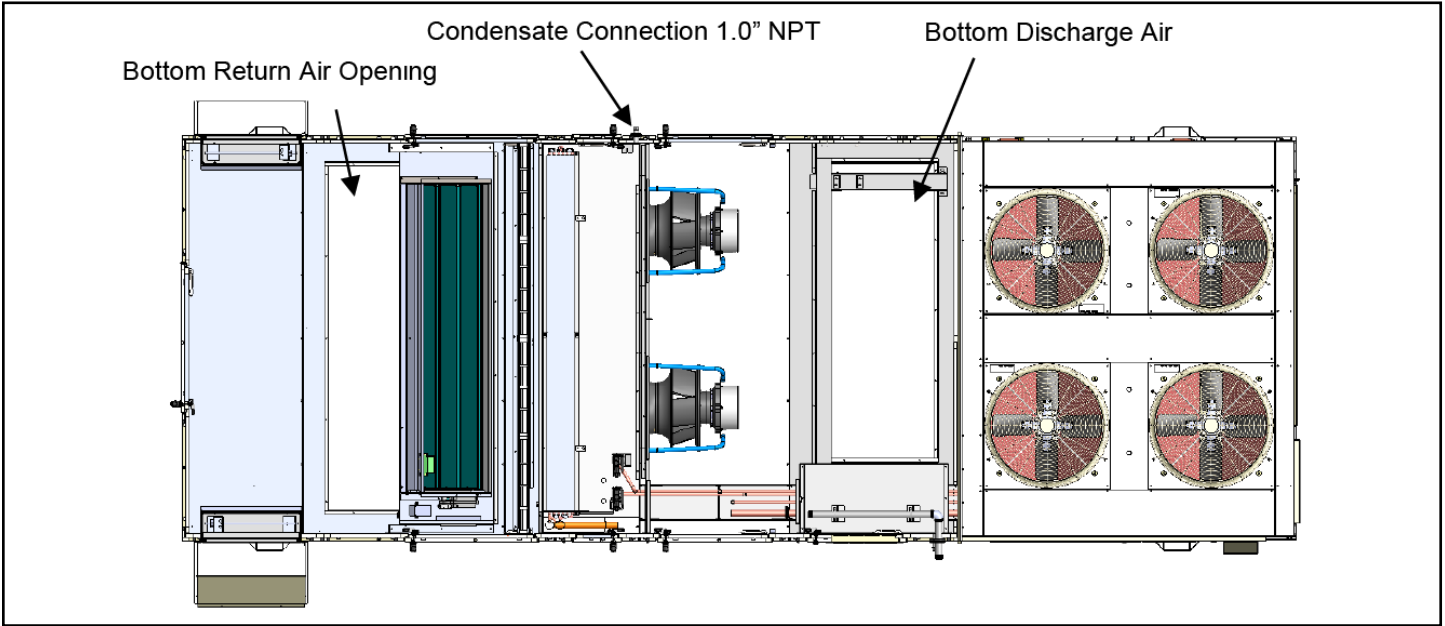
## Unit Description

Figure 2 shows a typical DPSA unit. Figure 3 shows a typical DPSA unit with the locations of the major components. These figures are for general information only. See the project's certified submittals for actual specific dimensions and locations.

Figure 2: DPSA Unit, Typical



**Figure 3: Typical Component Locations—DPSA Units (Top View)**



**Figure 4: Typical Component Locations—DPSA Units (Side View)**

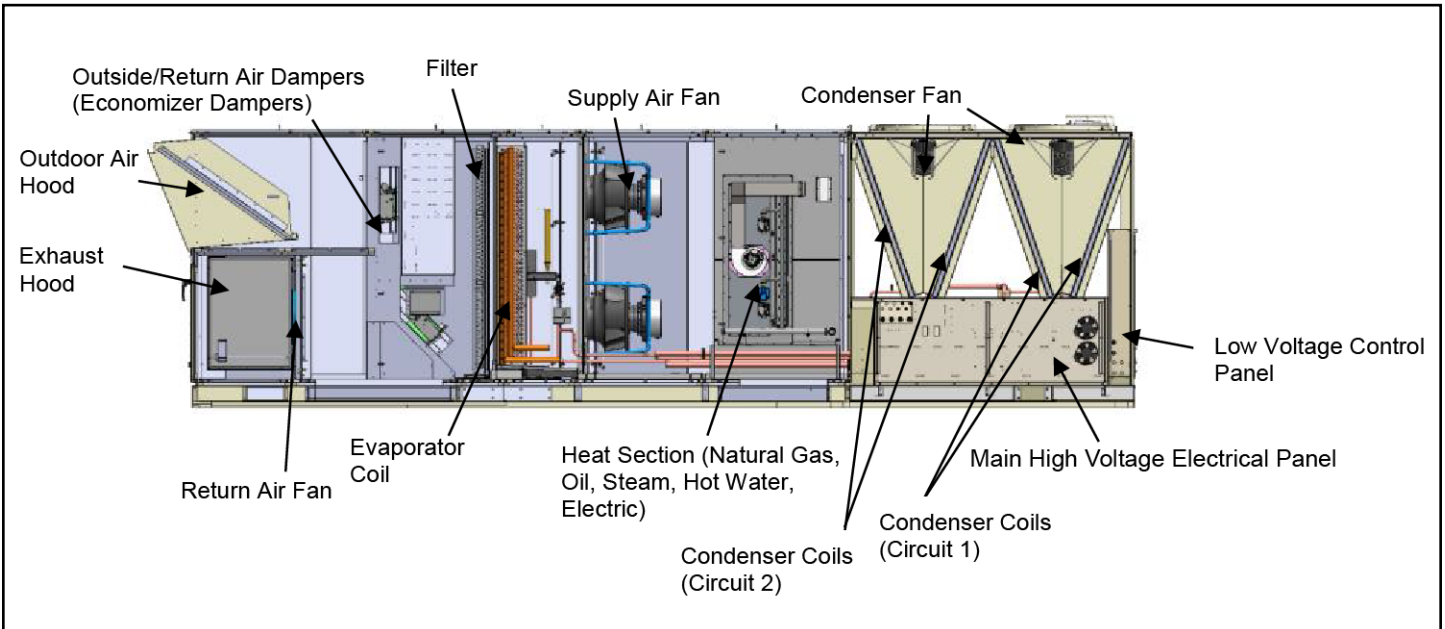


Figure 5: Typical Component Locations—DAHA Unit (Top View)

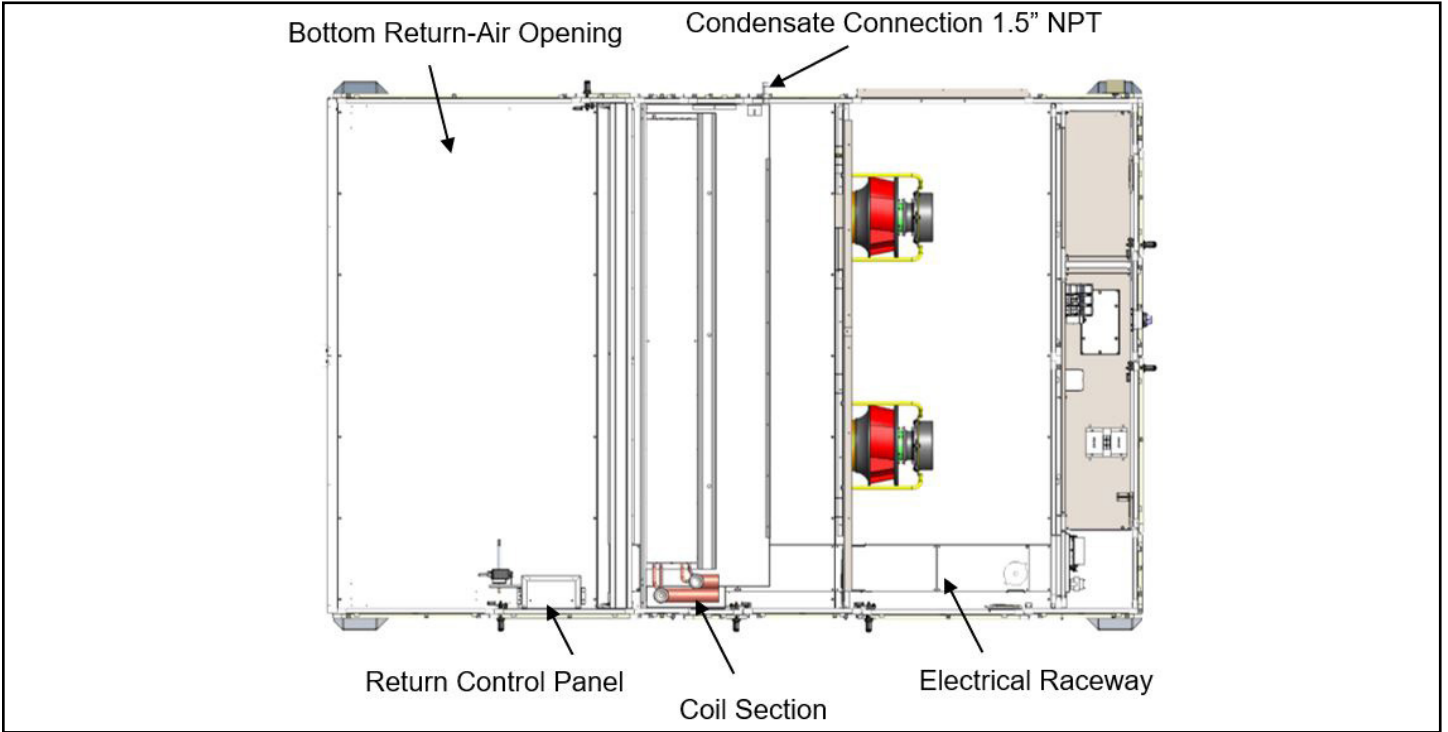


Figure 6: Typical Component Locations—DAHA Unit (Side View)

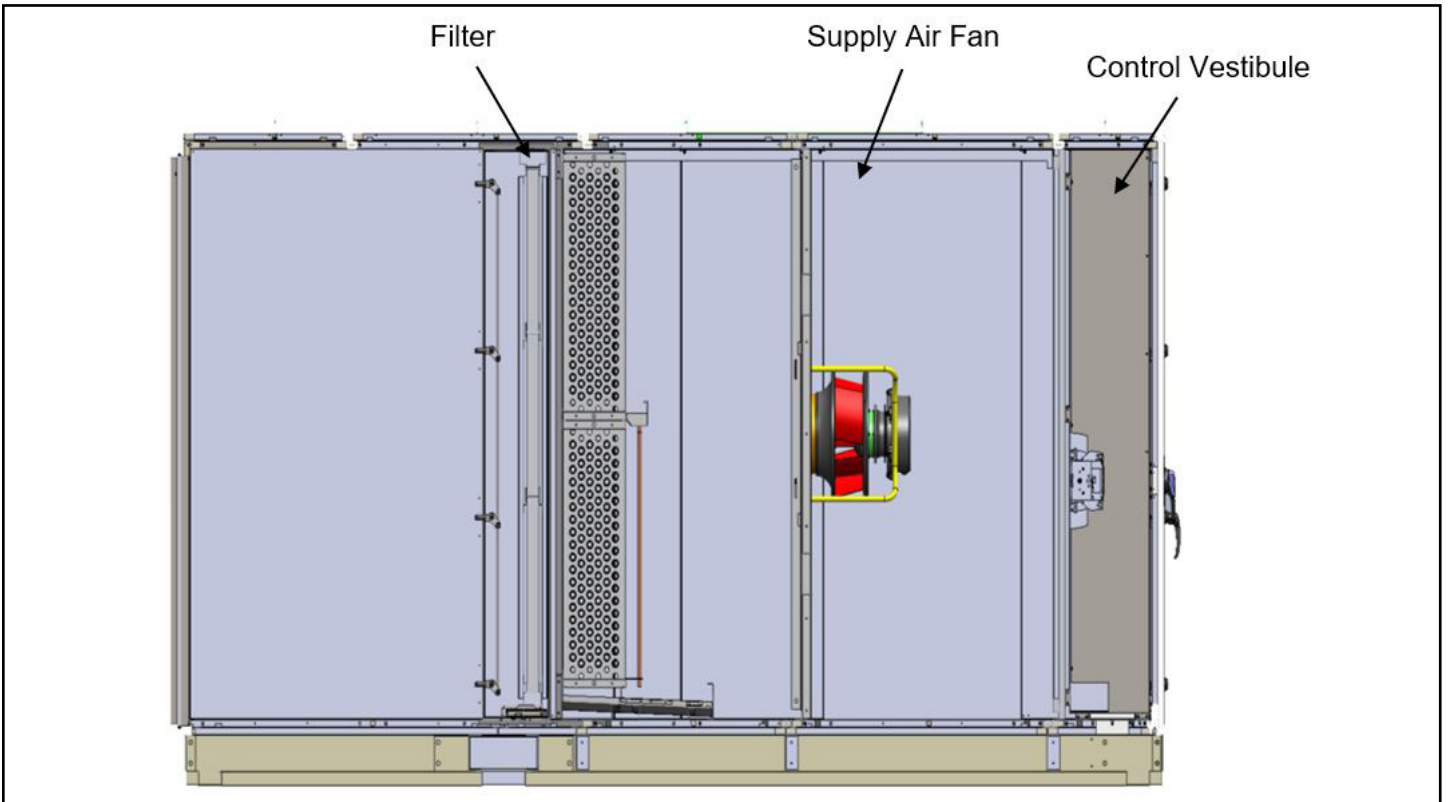
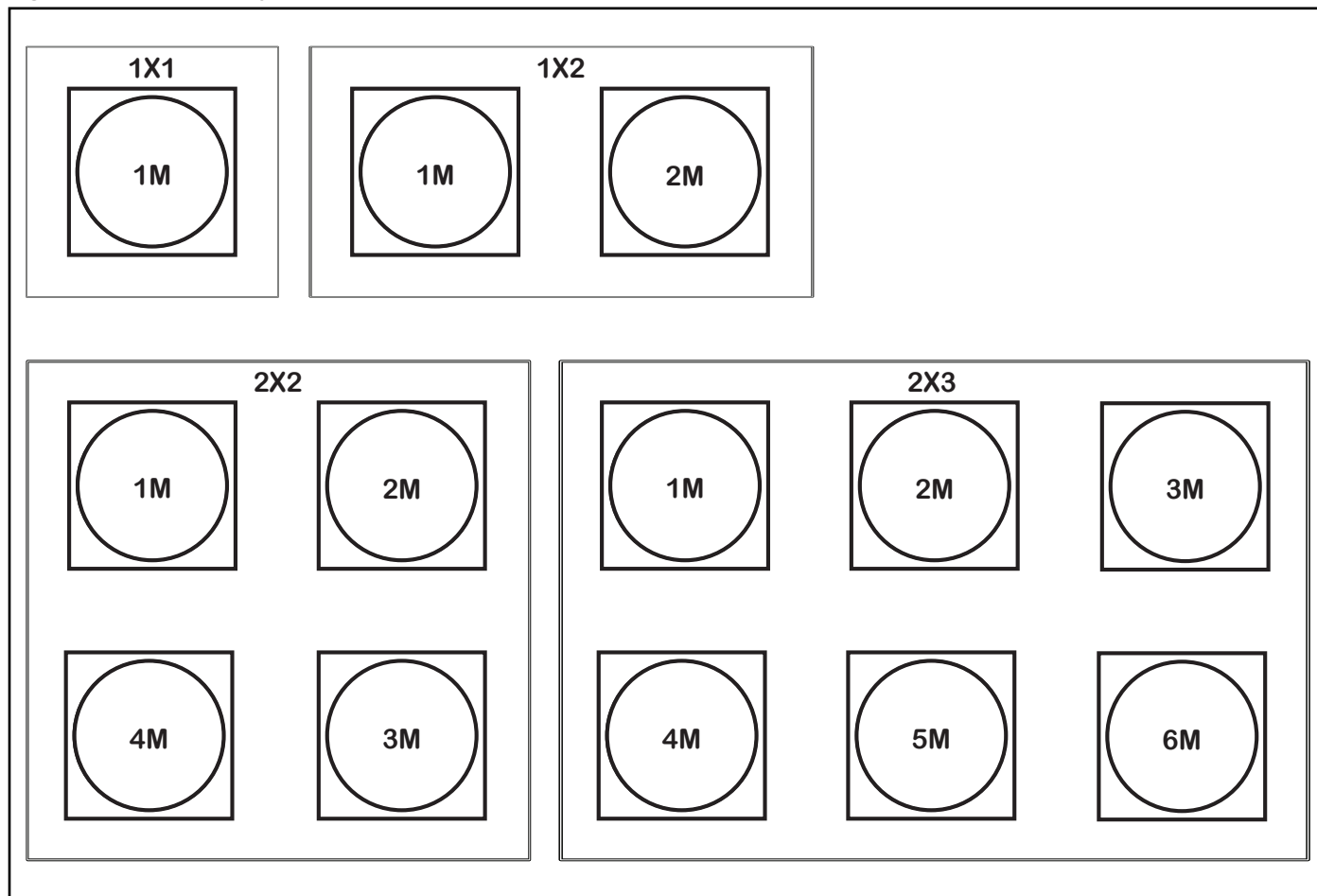


Figure 7: ECM Fan Array Identification

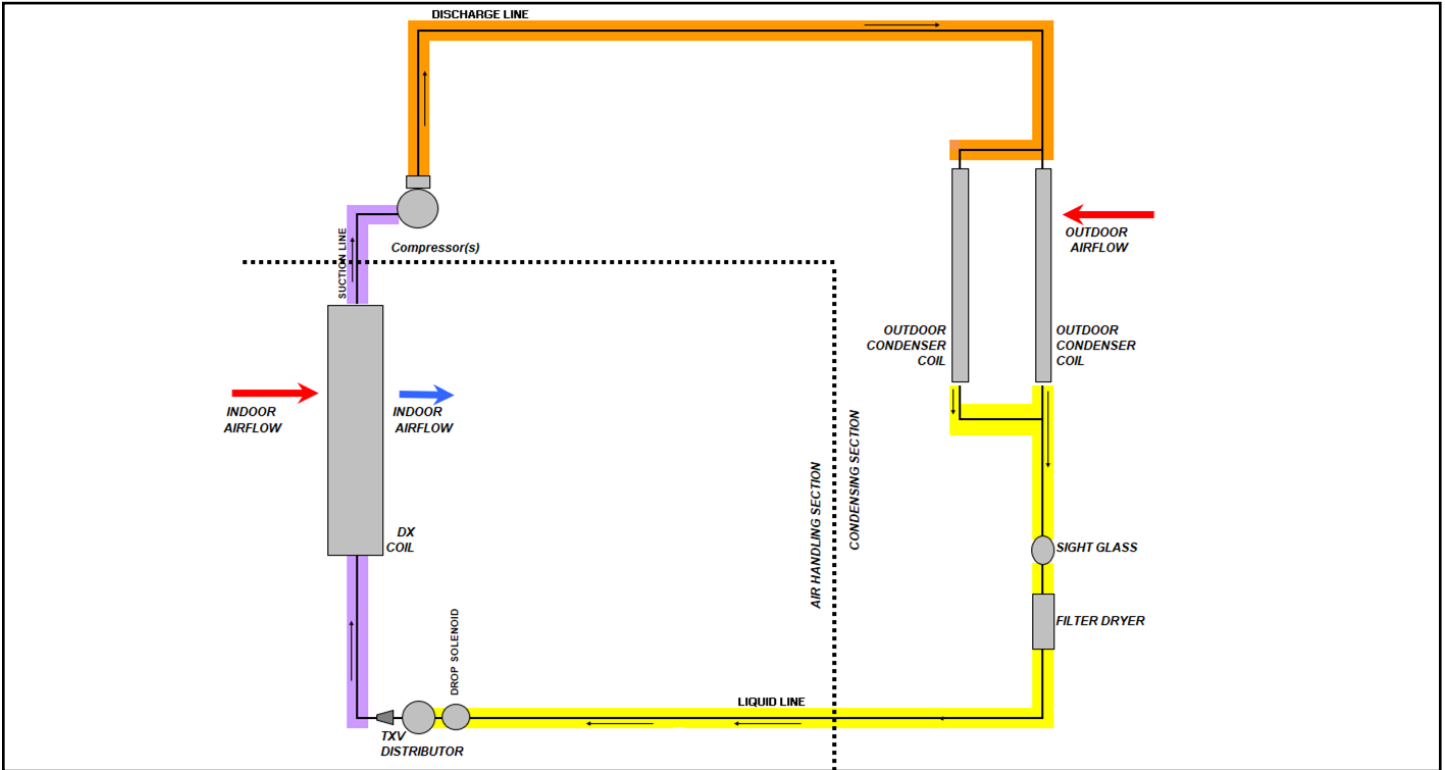


**NOTE:** MicroTech unit controller will communicate via modbus for M-marked fans.

# Refrigeration Piping

This section presents the unit refrigeration piping diagrams for the various available configurations.

**Figure 8: Schematic, Standard Circuit**



**Figure 9: Schematic, Hot Gas Bypass Circuit**

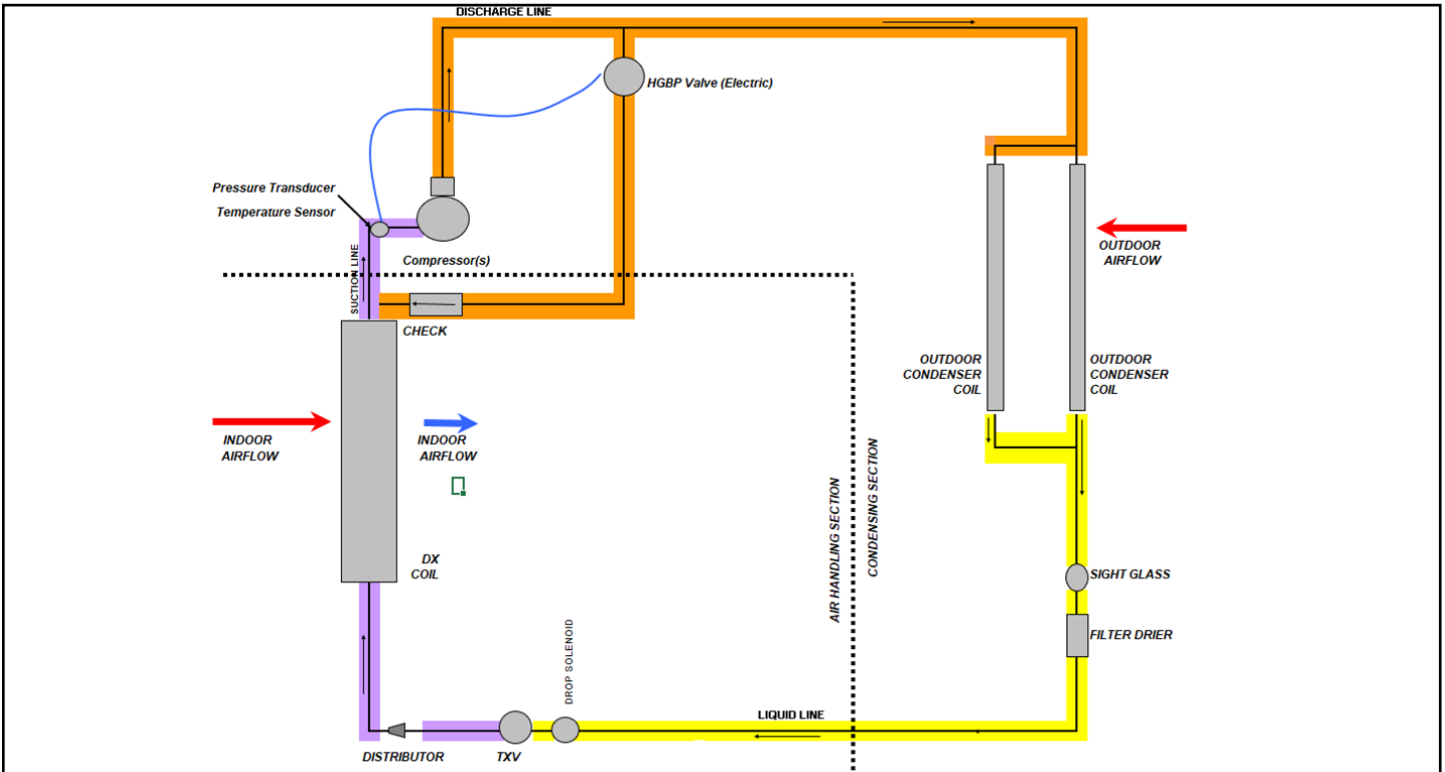


Figure 10: Schematic, MHGRH Circuit

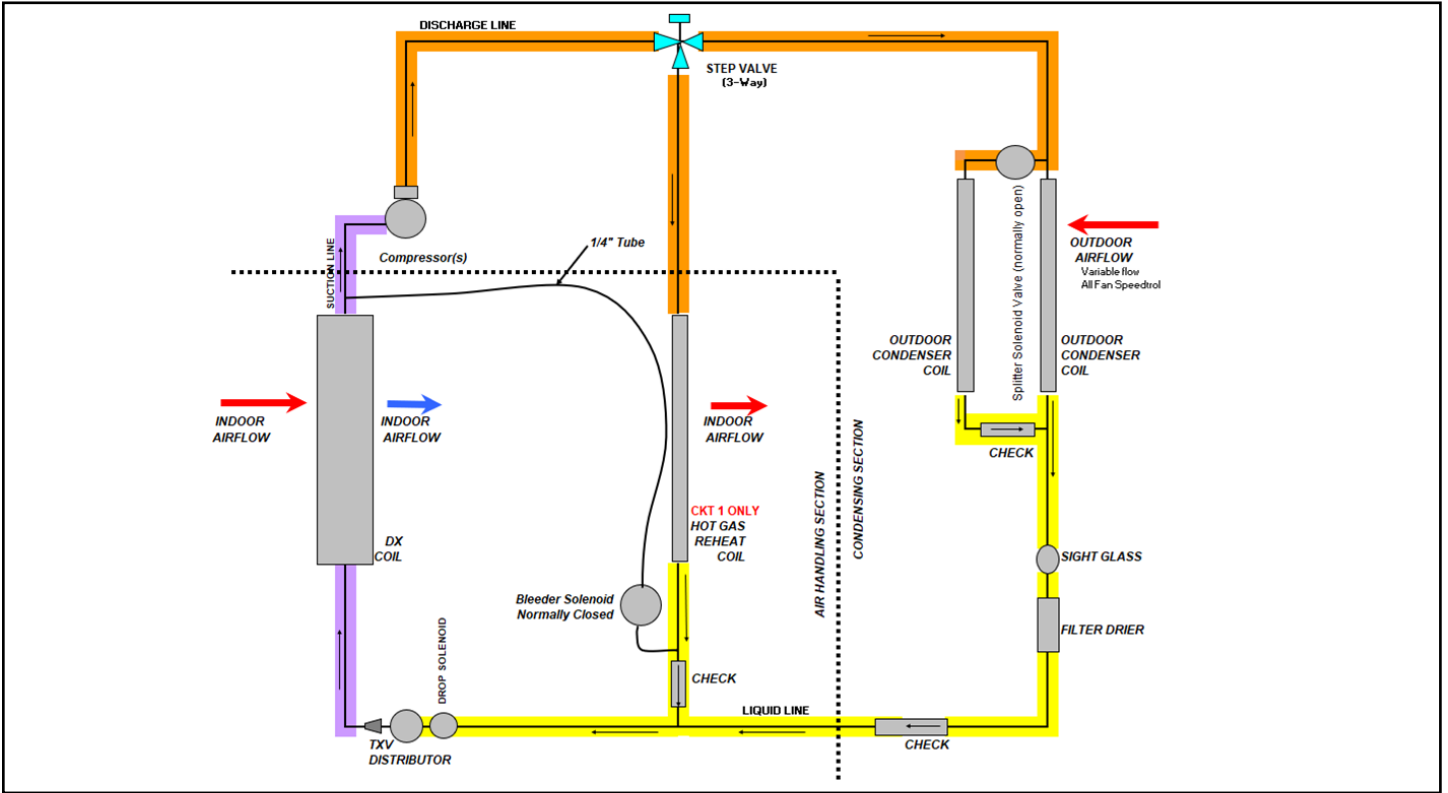


Figure 11: Schematic, LSCRH Circuit 1

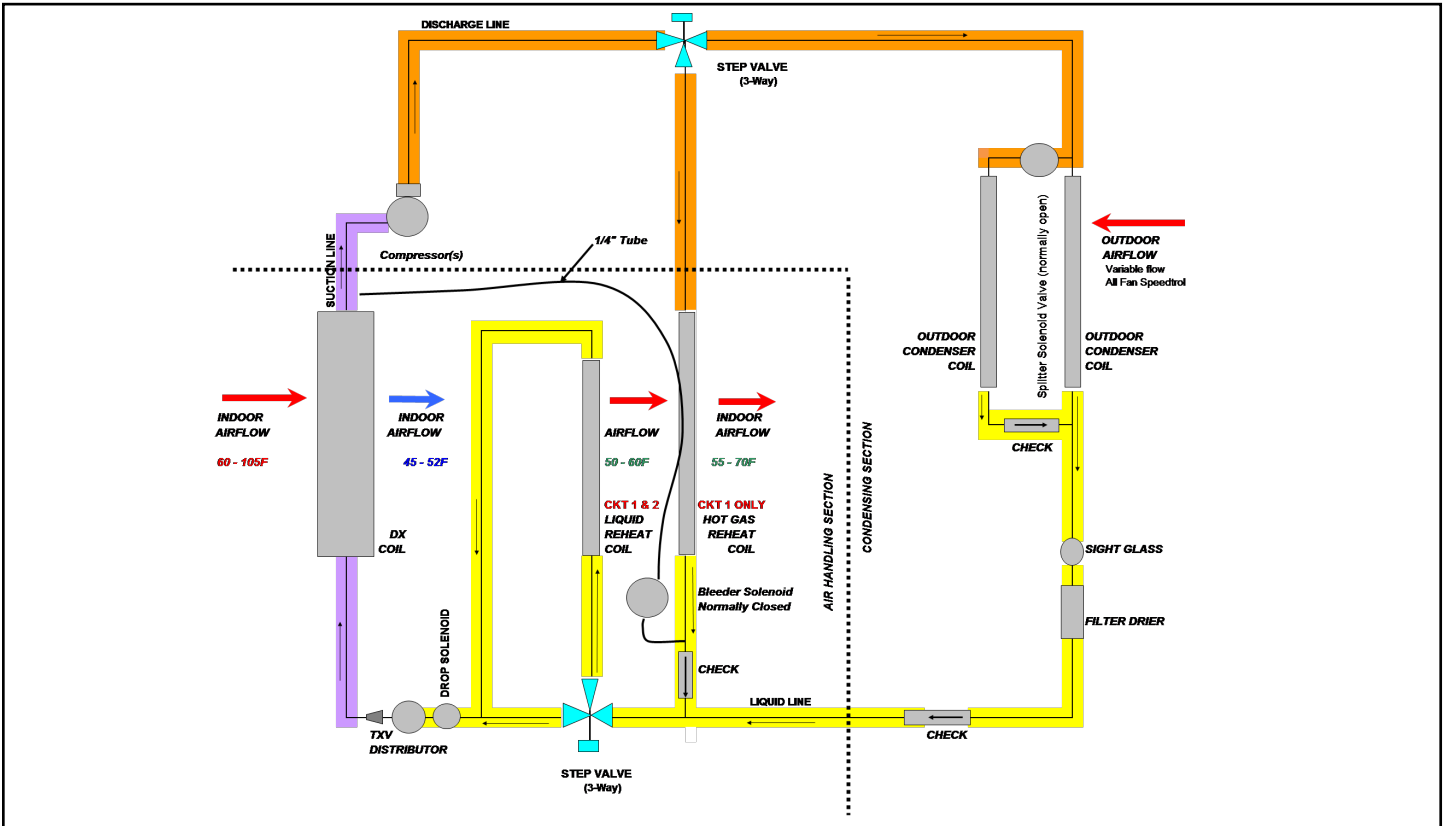


Figure 12: Schematic, LSCRH Circuit 2

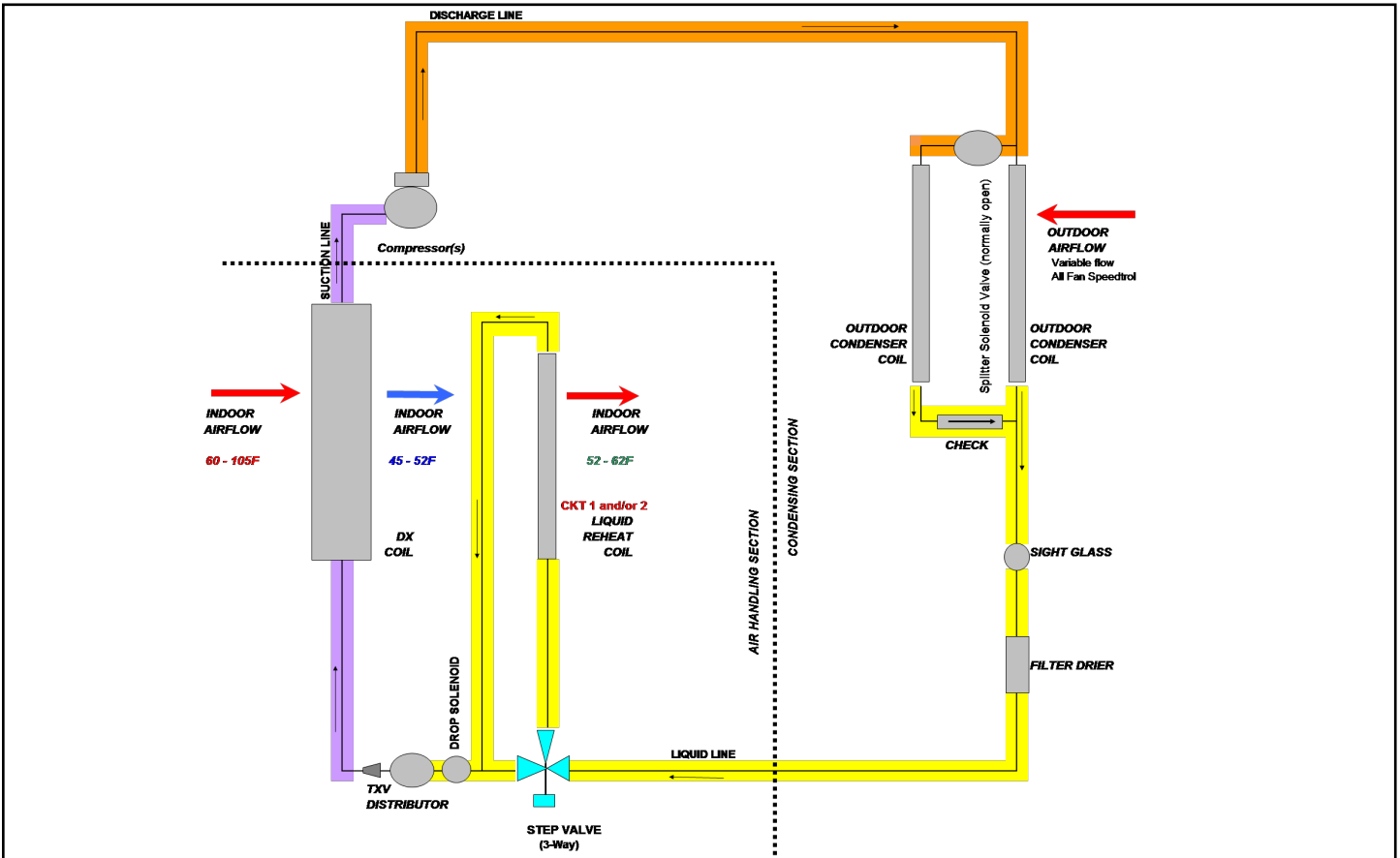
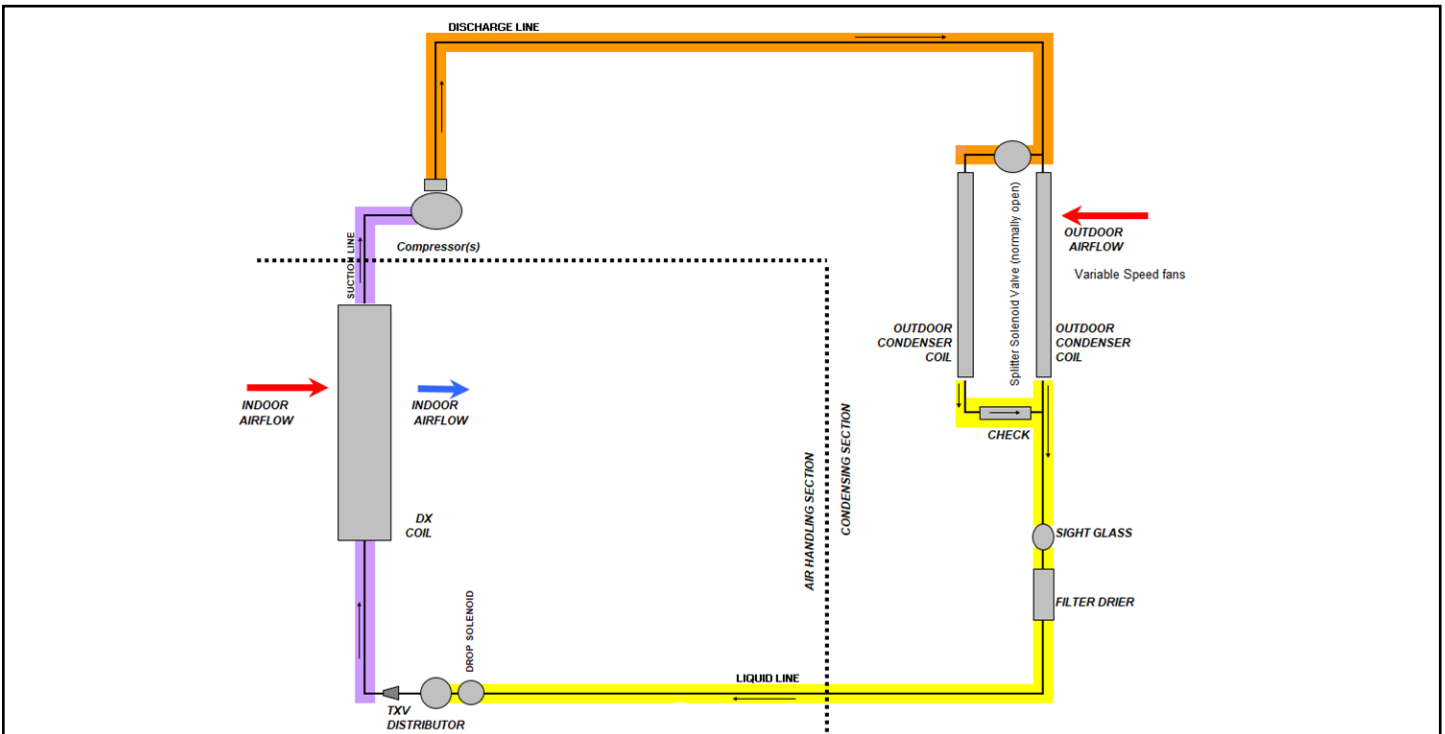


Figure 13: Low Ambient Circuit Schematic



Low Ambient Configurations  
 Speedtrol (Variable speed fans) down to 25°F (-4°C)  
 Speedtrol (Variable speed fans) + splitter solenoid down to -10°F (-23°C)

Figure 14: Schematic, Heat Pump, Variable Speed Compressor, MHGRH

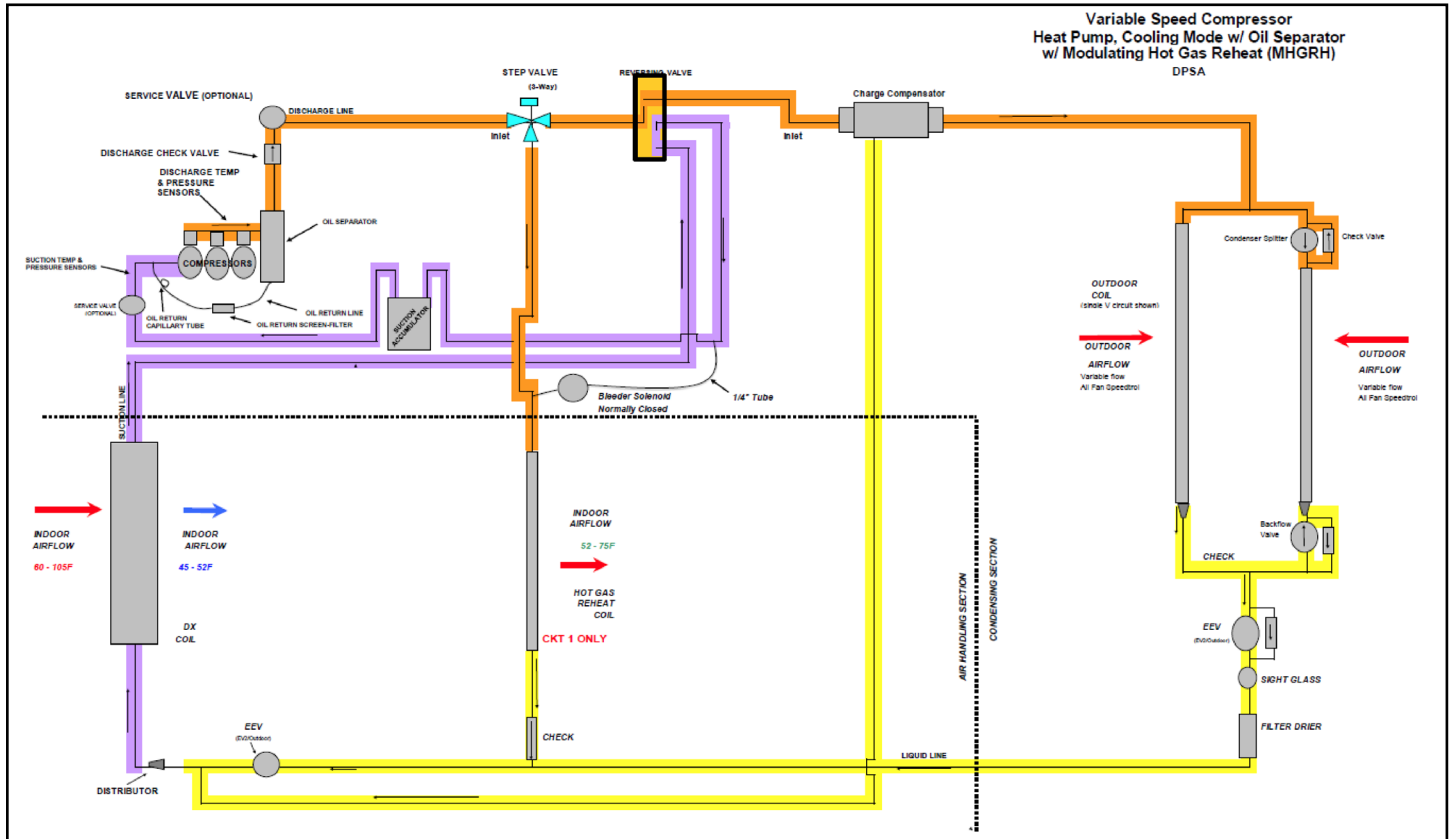


Figure 15: Schematic, Heat Pump, Variable Speed Compressor, Cooling Mode

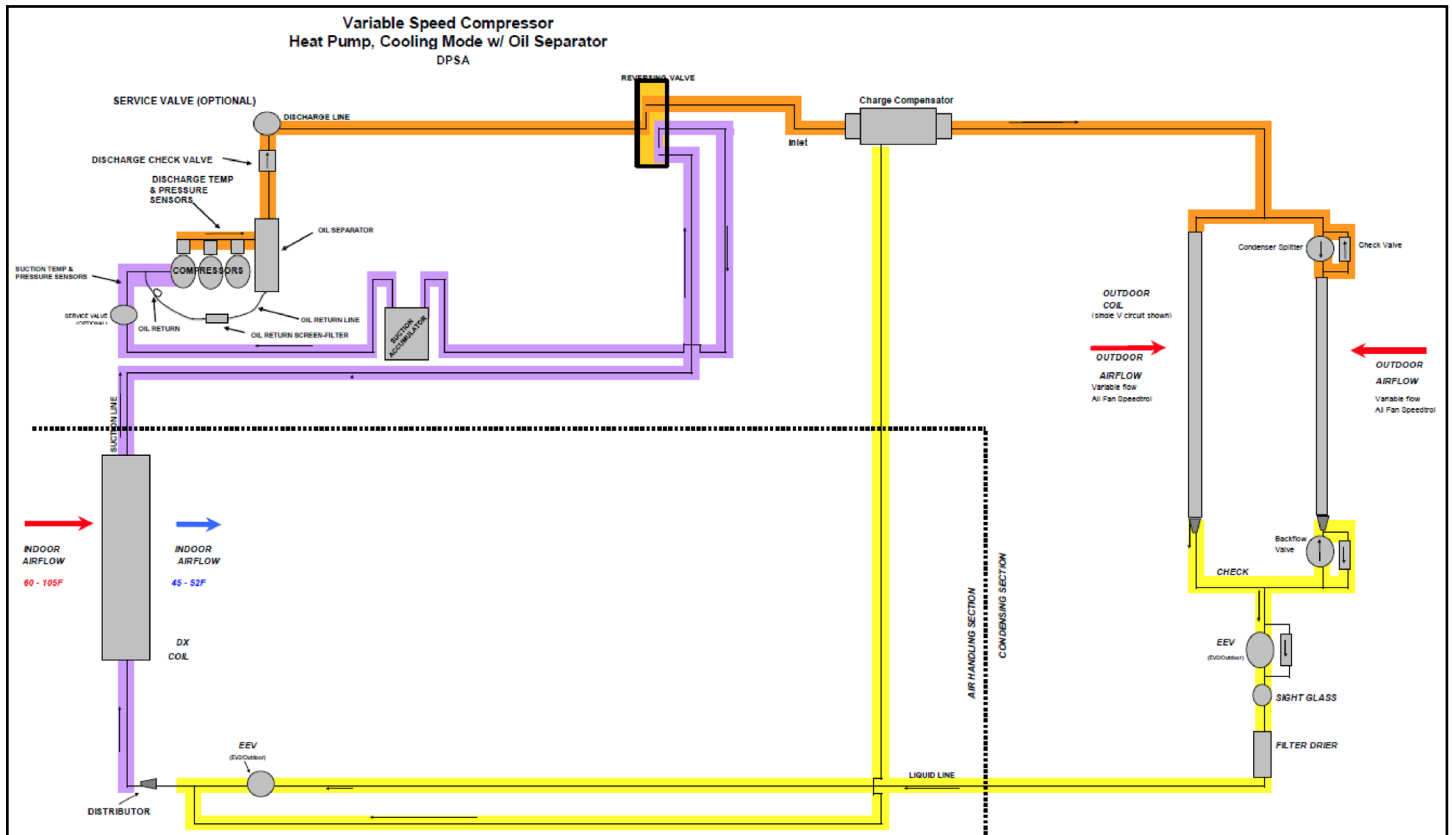
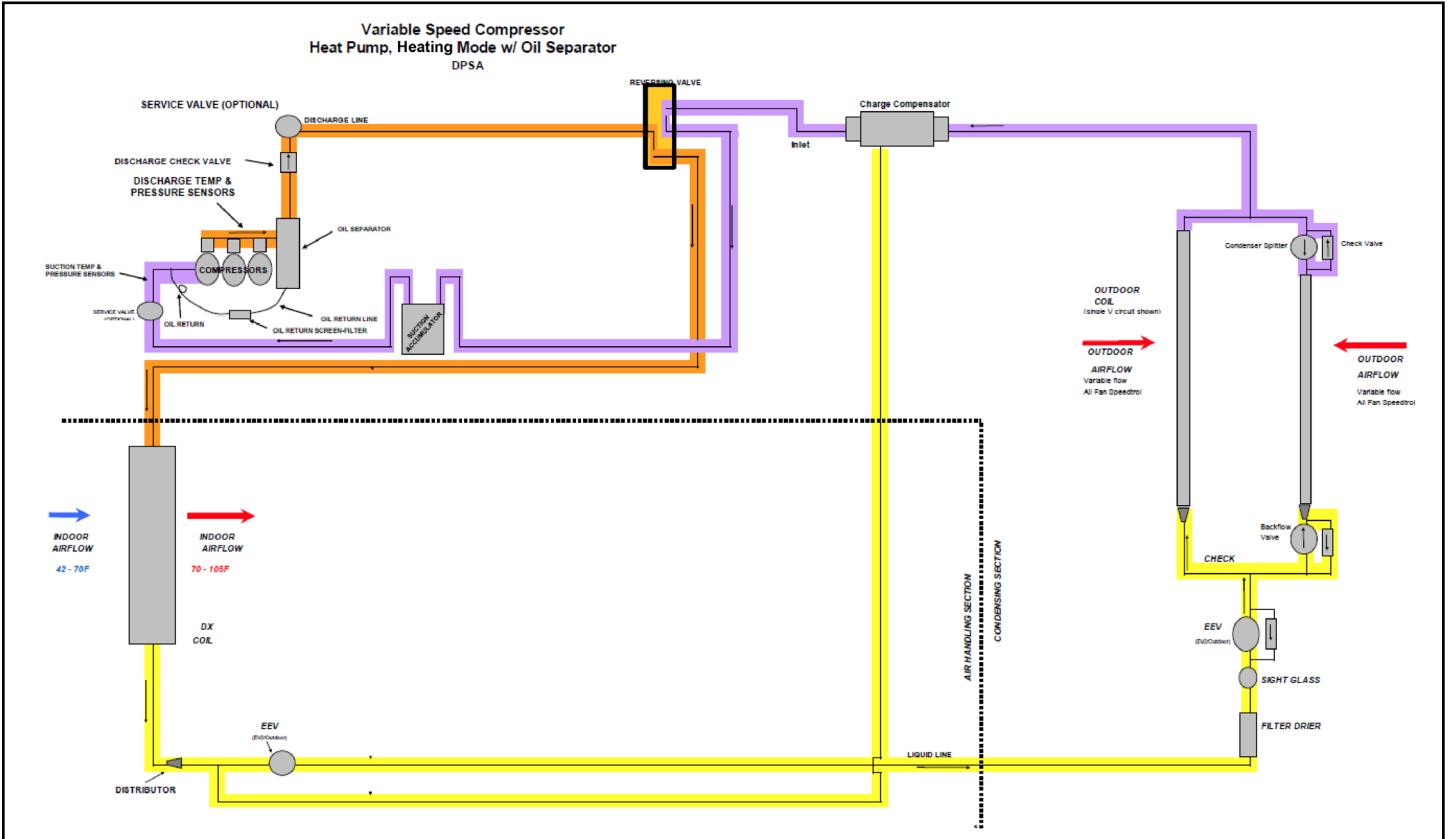
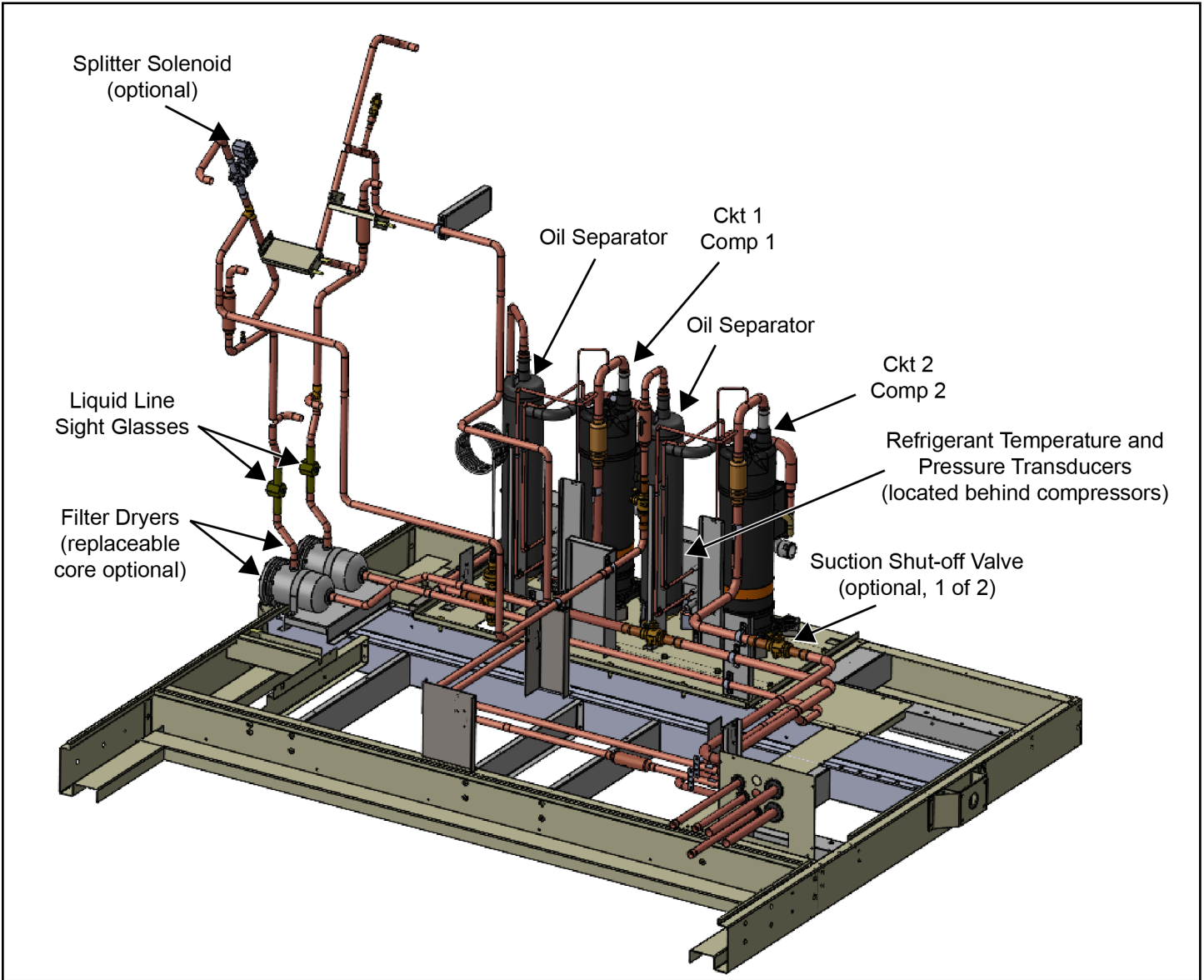


Figure 16: Schematic, Heat Pump, Variable Speed Compressor, Heating Mode

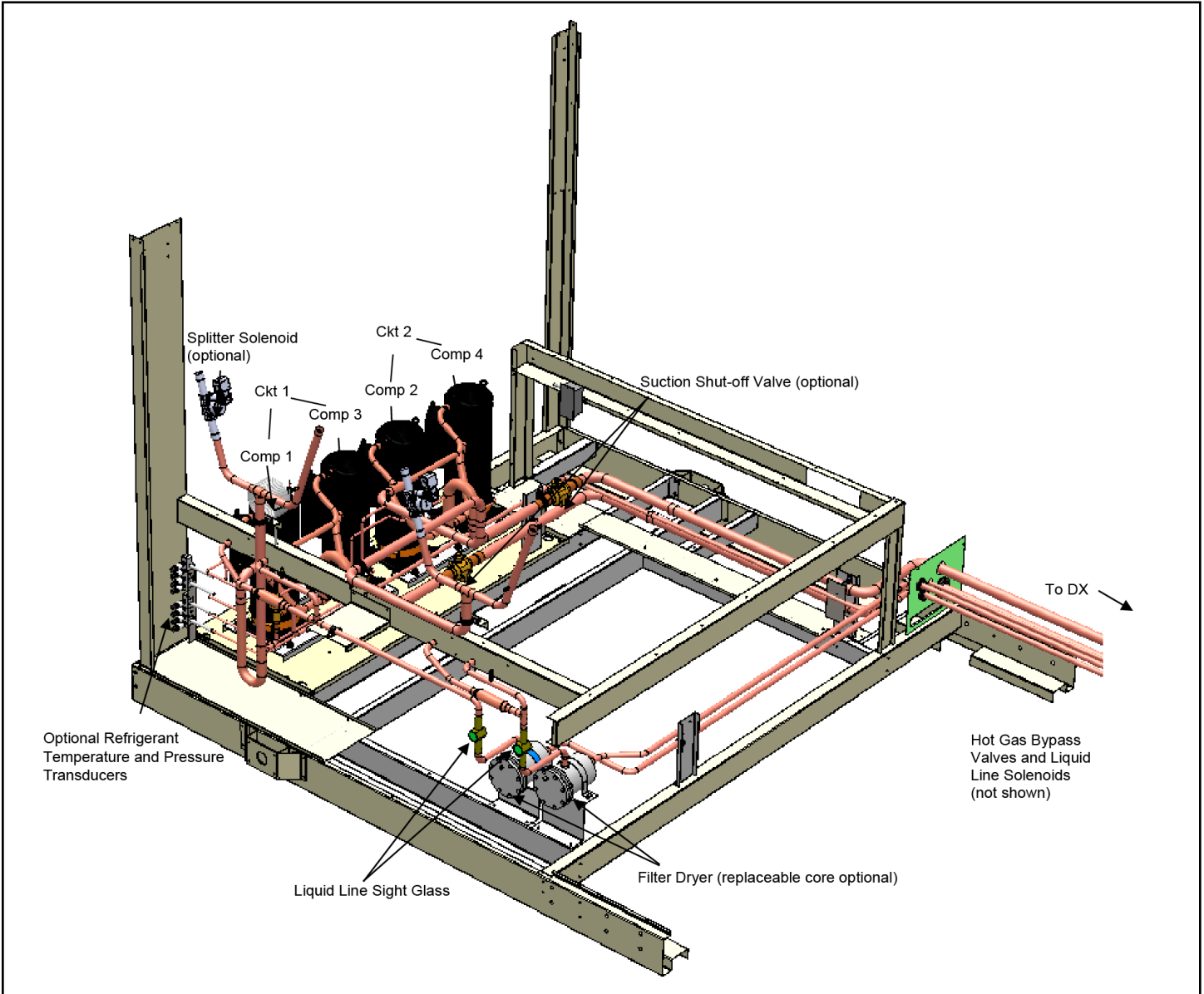


# Condenser and Compressor Piping

Figure 17: A-Cabinet Condenser Piping, Cooling Only



**Figure 18: B-Cabinet Condenser Piping, Cooling Only, 1 to 2 Compressors per Circuit are Provided**



**NOTE:** Unit with 4 fixed-speed compressors shown.

Figure 19: B-Cabinet Heat Pump Piping

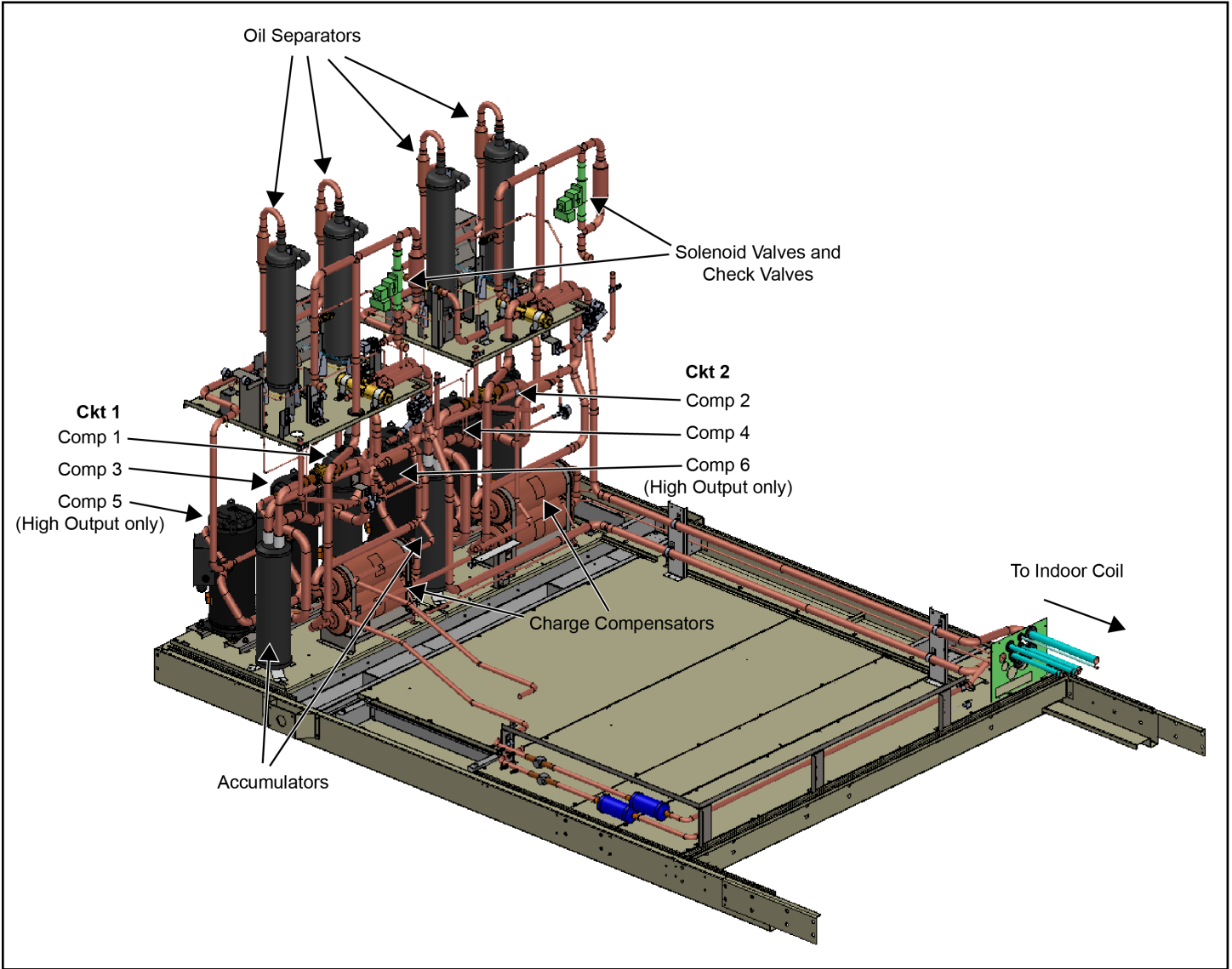


Figure 20: C-Cabinet Condenser Piping, Cooling Only, 1 to 2 Compressors per Circuit are Provided

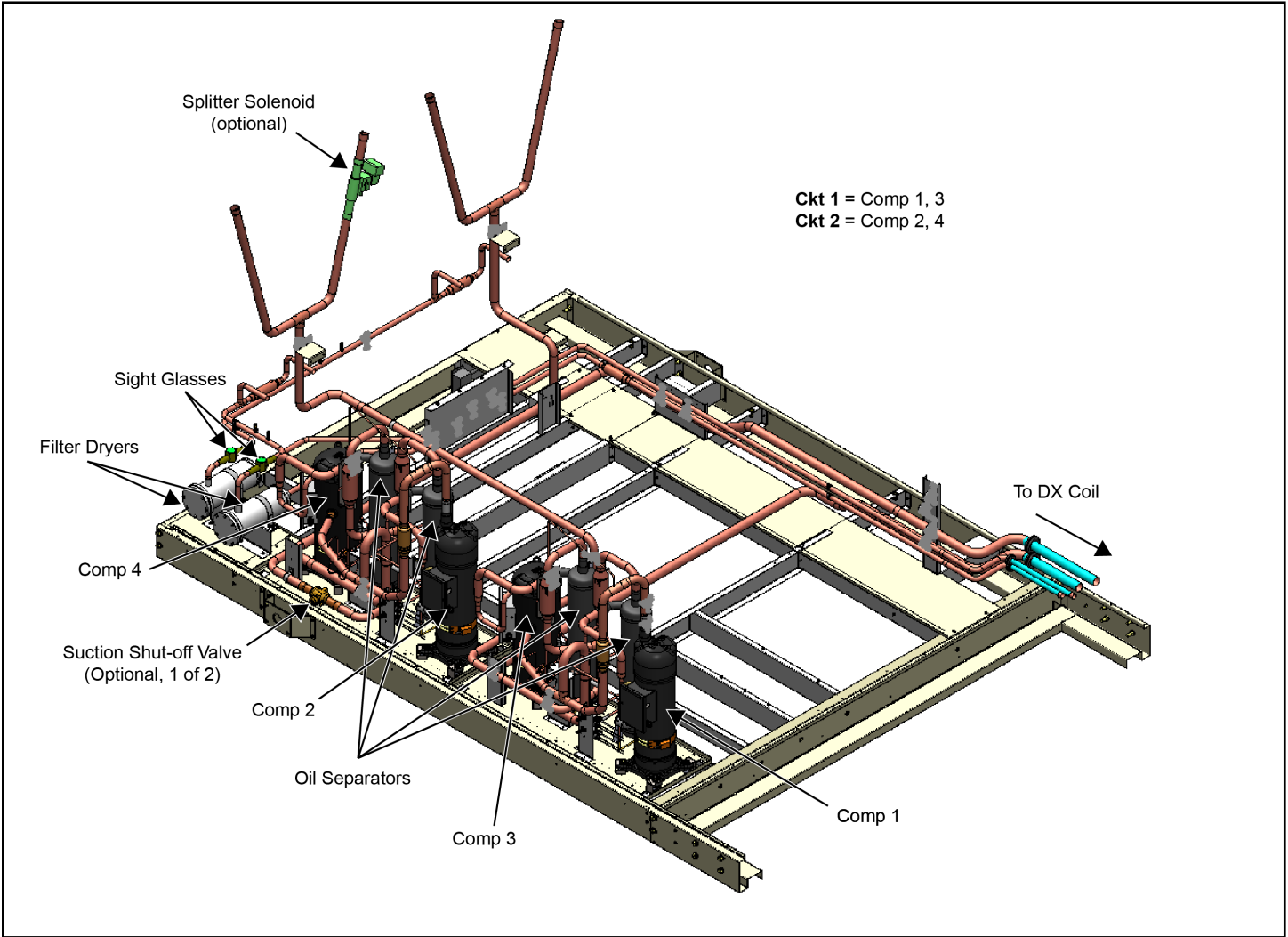


Figure 21: C-Cabinet Heat Pump Piping

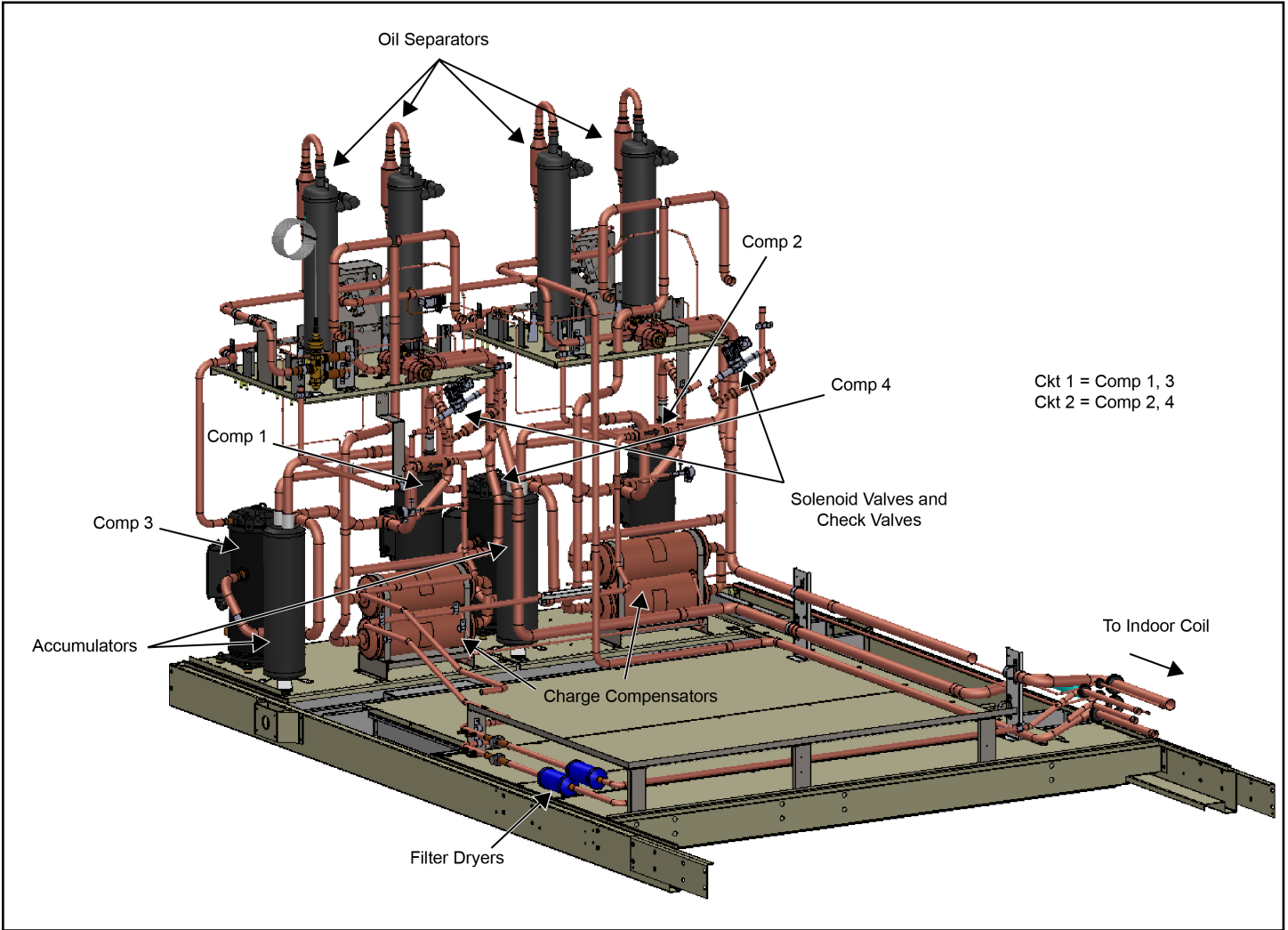


Figure 22: D-Cabinet Condenser Piping, Cooling Only

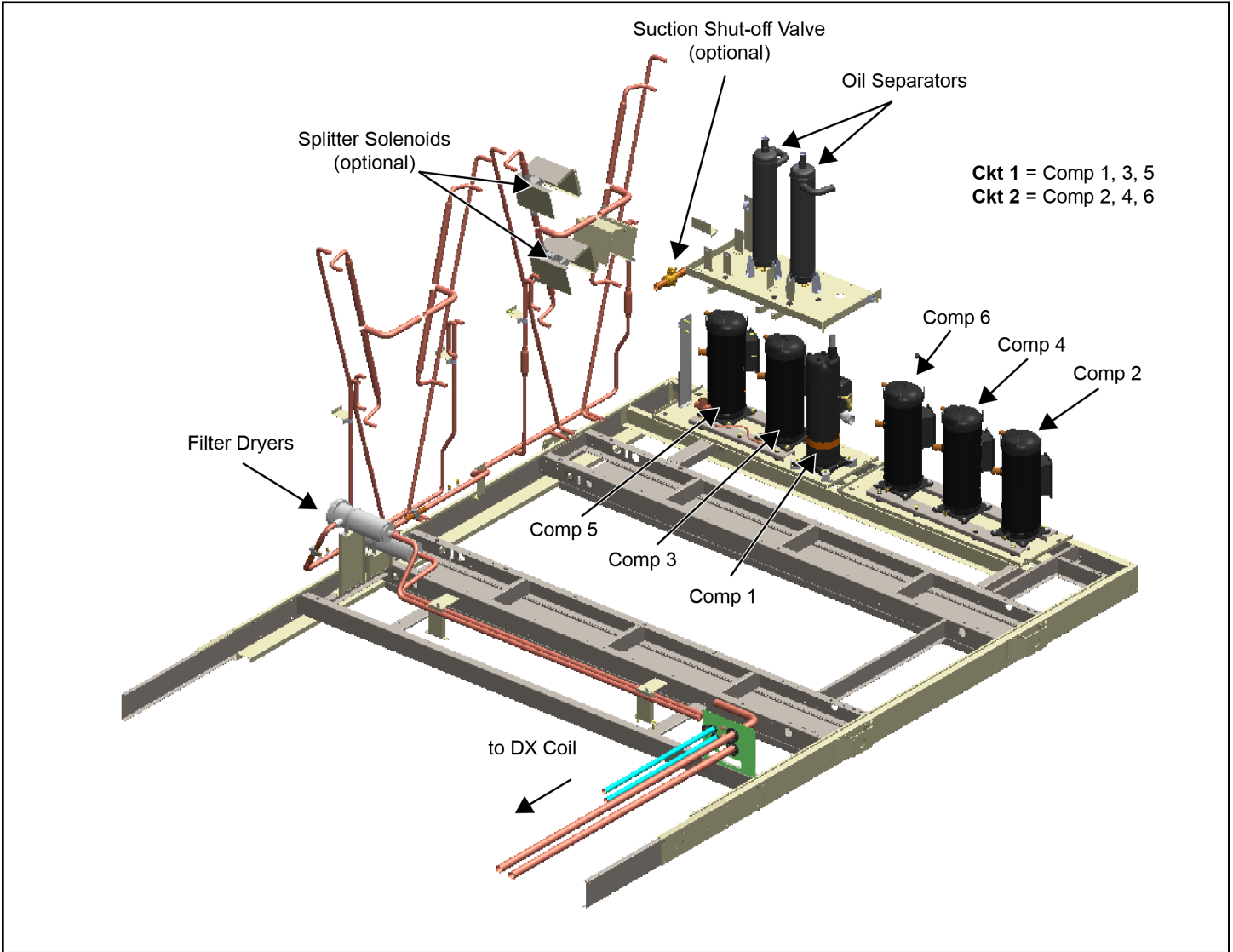


Figure 23: E-Cabinet Condenser Piping, Cooling Only

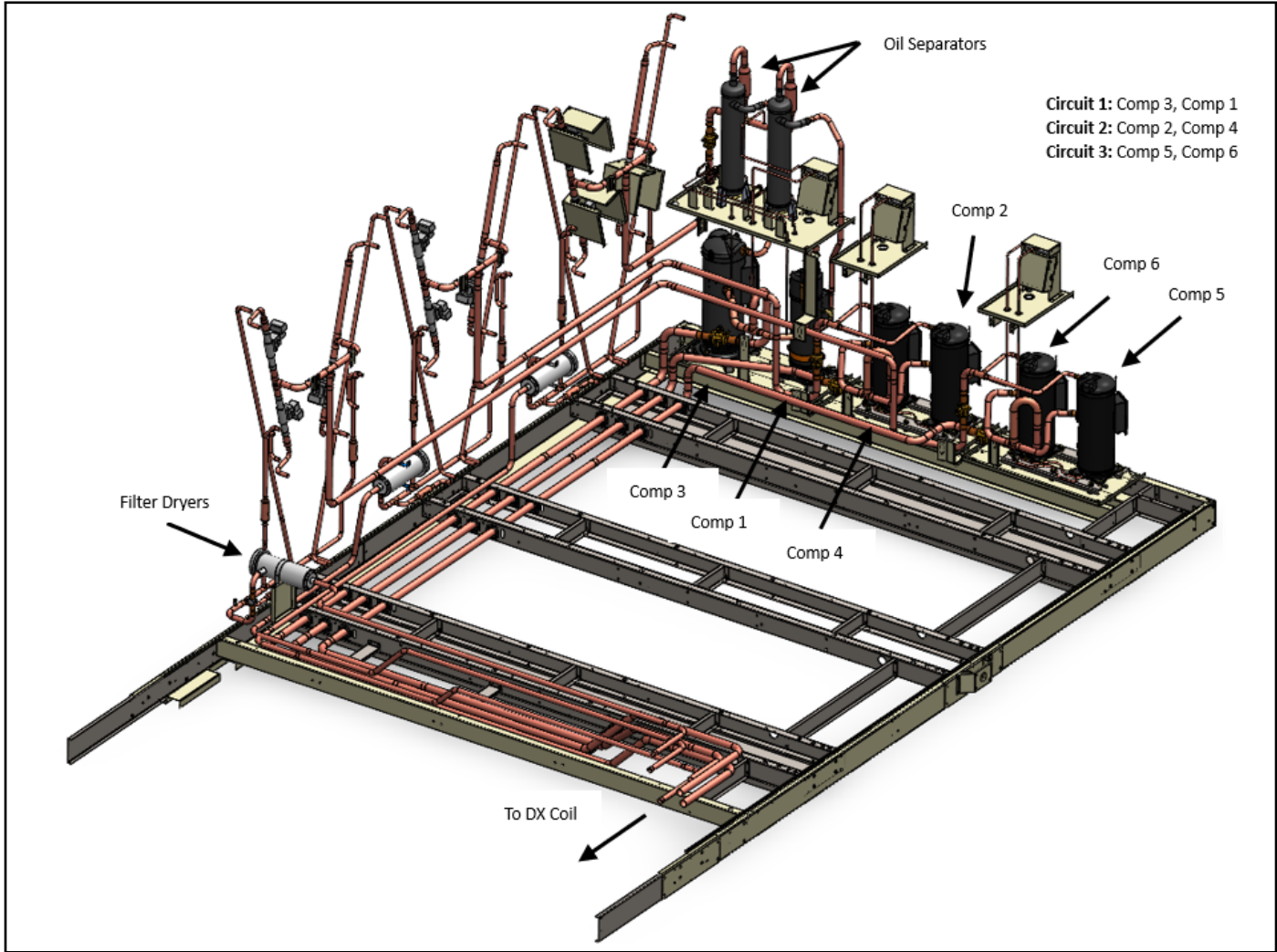
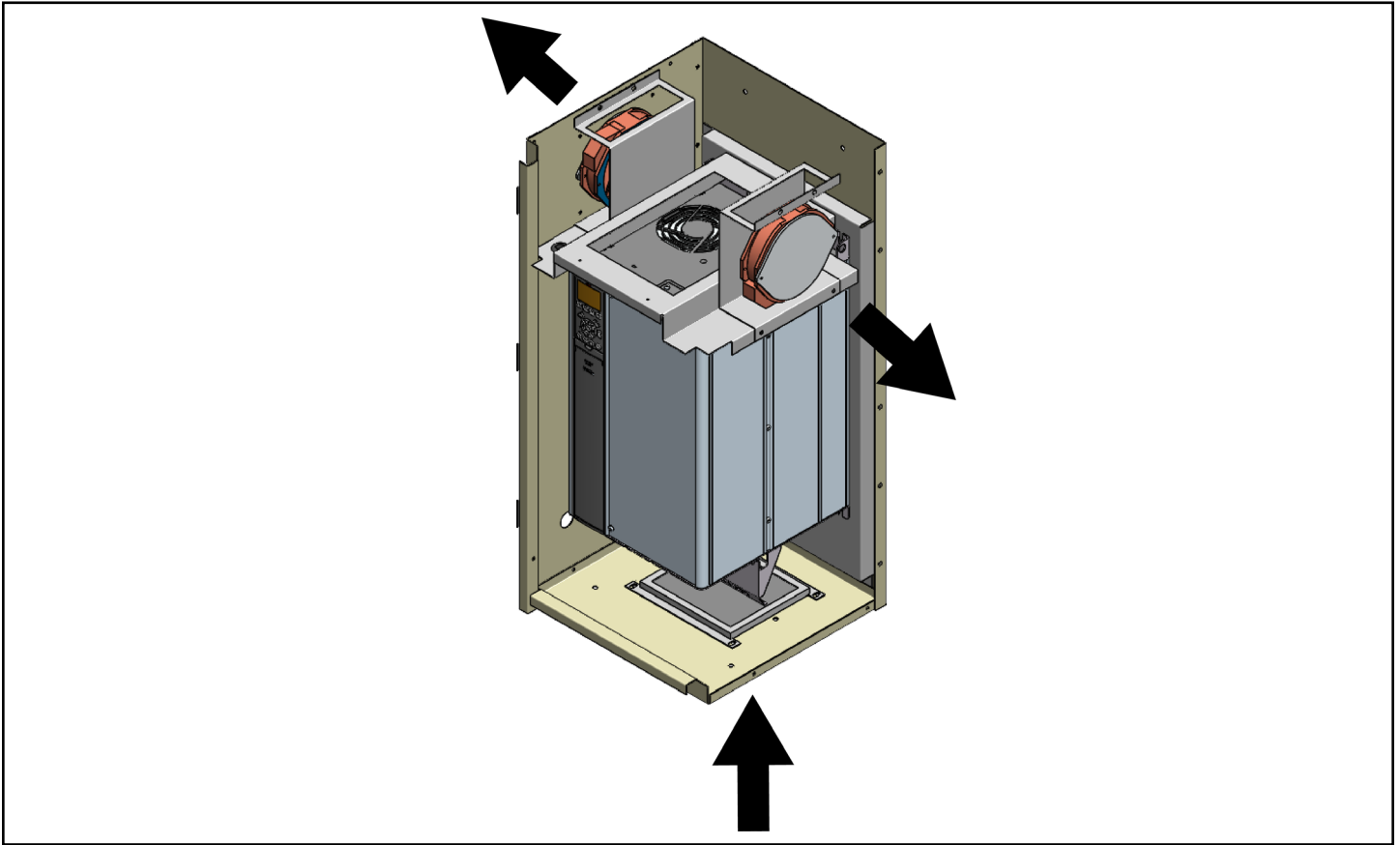


Figure 24: VFD Inverter Box Components

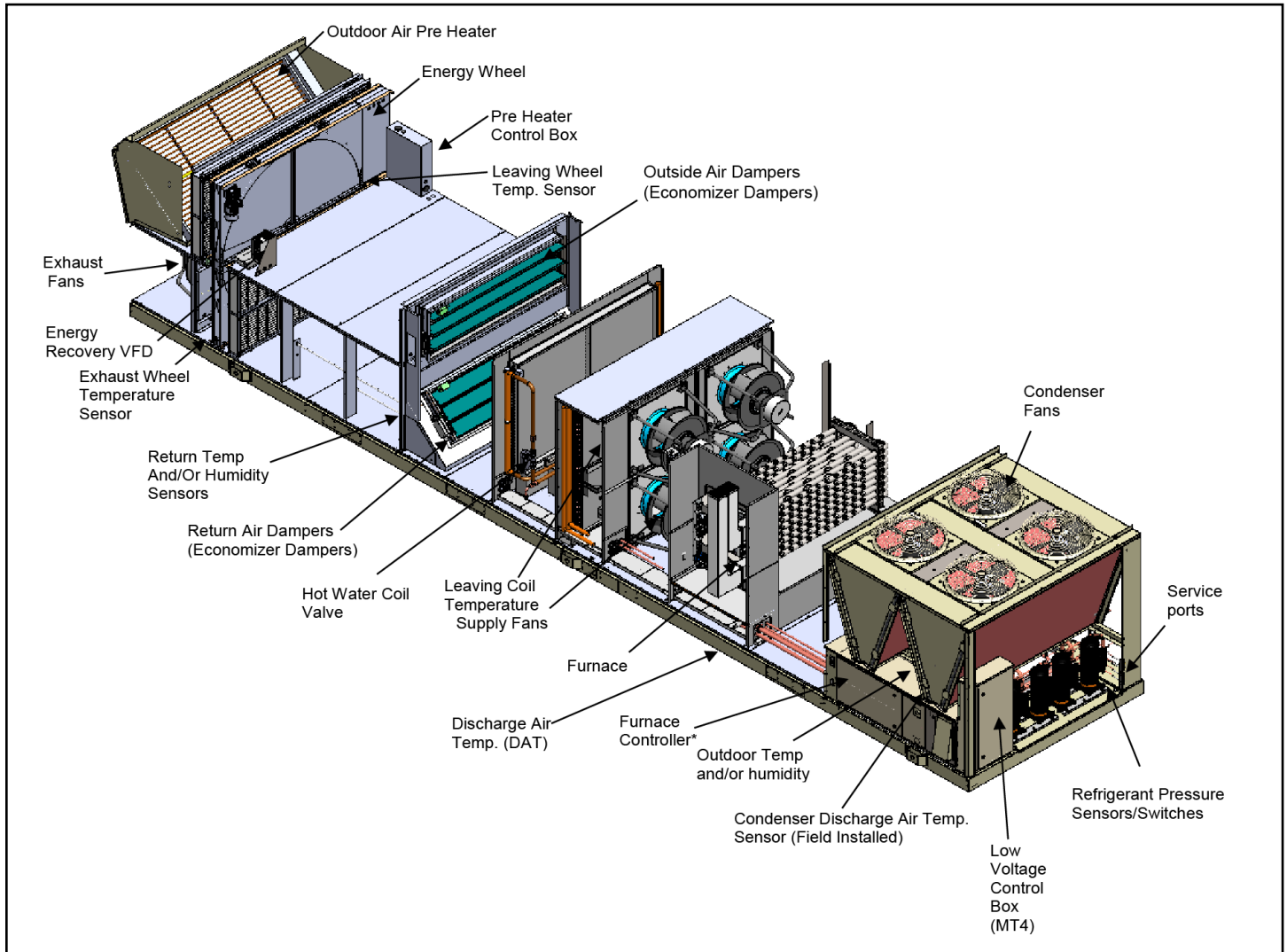


**NOTE:** Arrows indicate airflow direction.

# Controlled Component Locations

Figure 25 shows basic control and component locations within a typical unit.

**Figure 25: Typical Control and Component Locations**

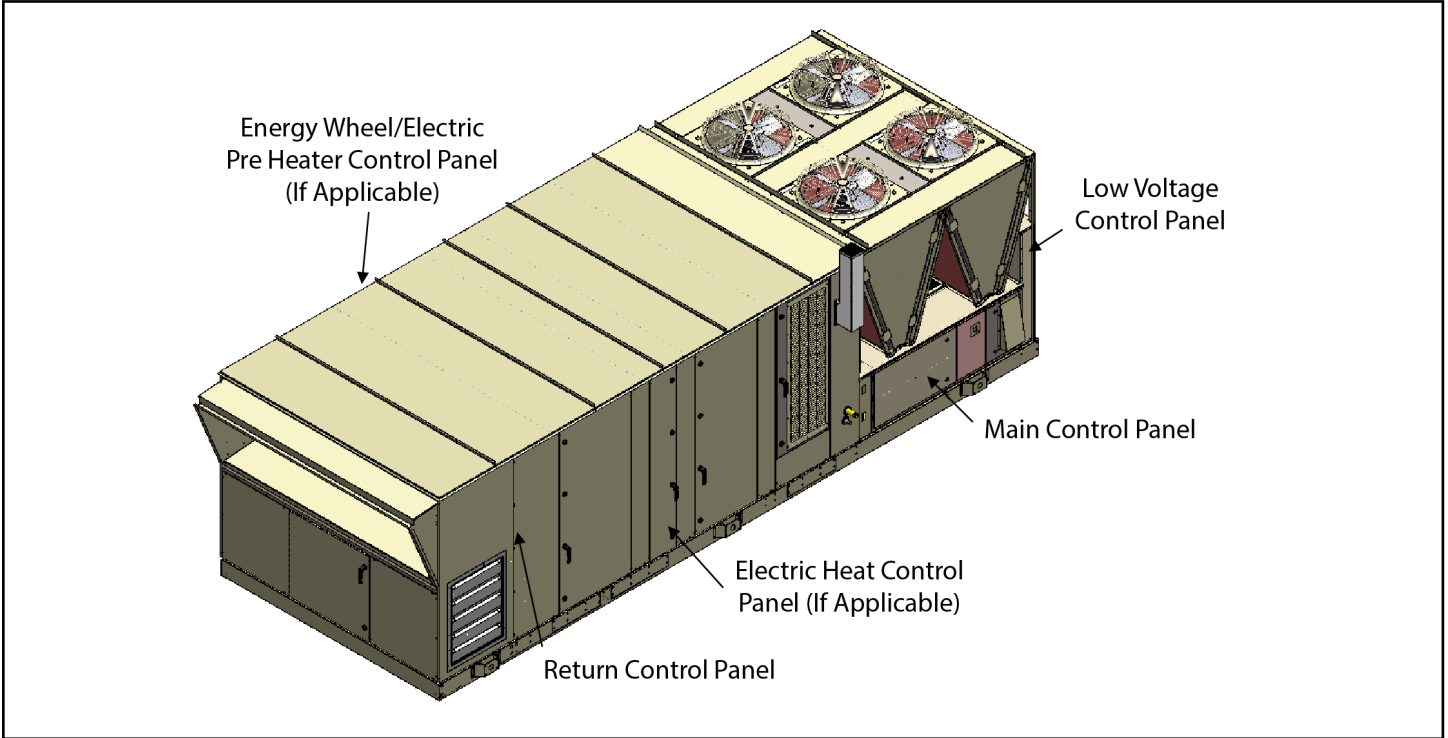


**NOTE:** \*Furnace controller located in furnace vestibule for D and E-Cabinet units.

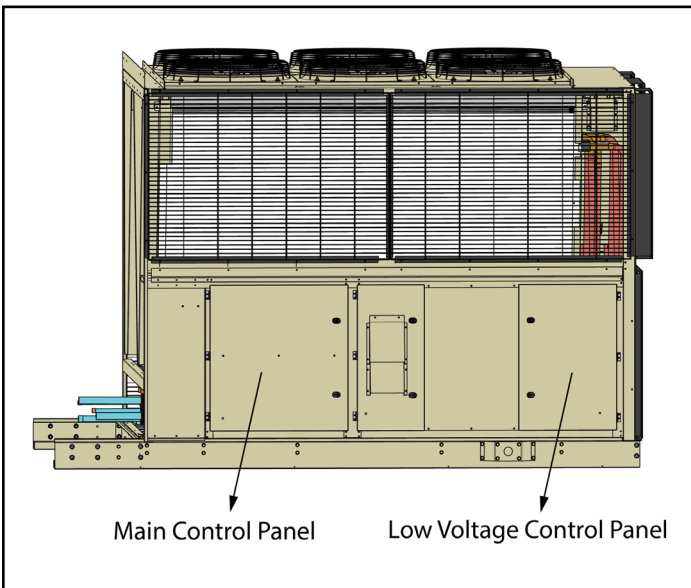
## Control Panel

The unit control panels and their locations are shown in the following figures. These figures show a typical unit. Specific unit configurations may differ.

**Figure 26: Control Panel Locations (DPSA Unit)**



**Figure 27: C Cabinet Control Panel Locations (DPSA Unit)**



**Figure 28: D Cabinet Control Panel Locations (DPSA Unit)**

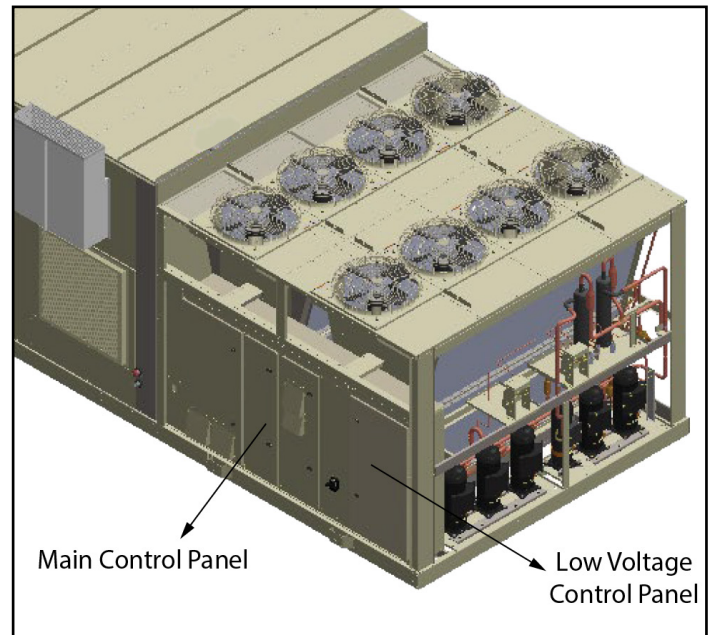


Figure 29: E Cabinet Control Panel Locations (DPSA Unit)

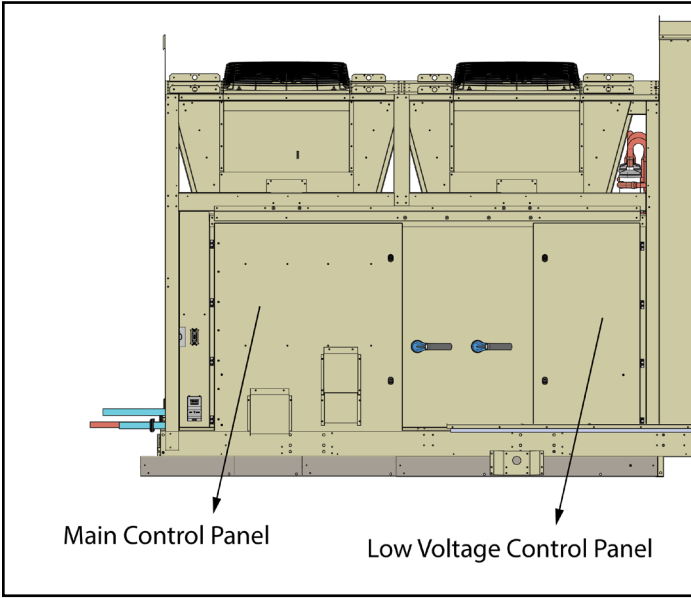


Figure 30: Control Panel Locations (DAHA Unit)

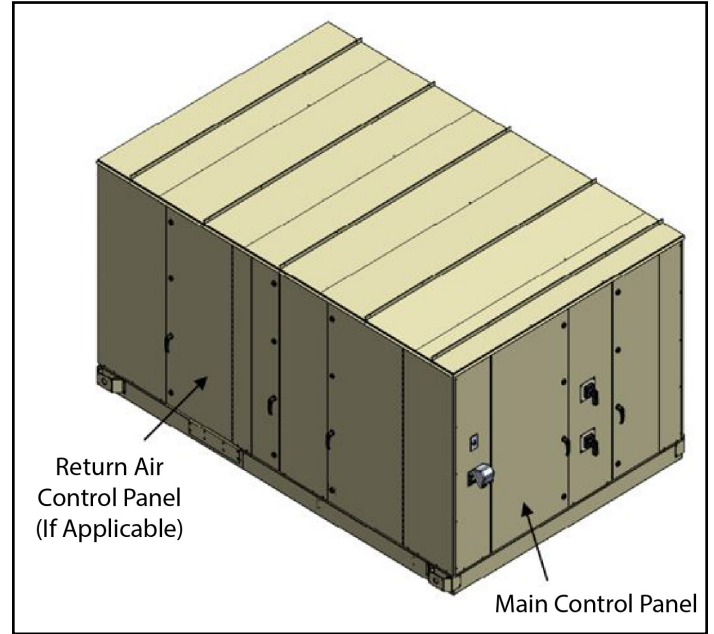
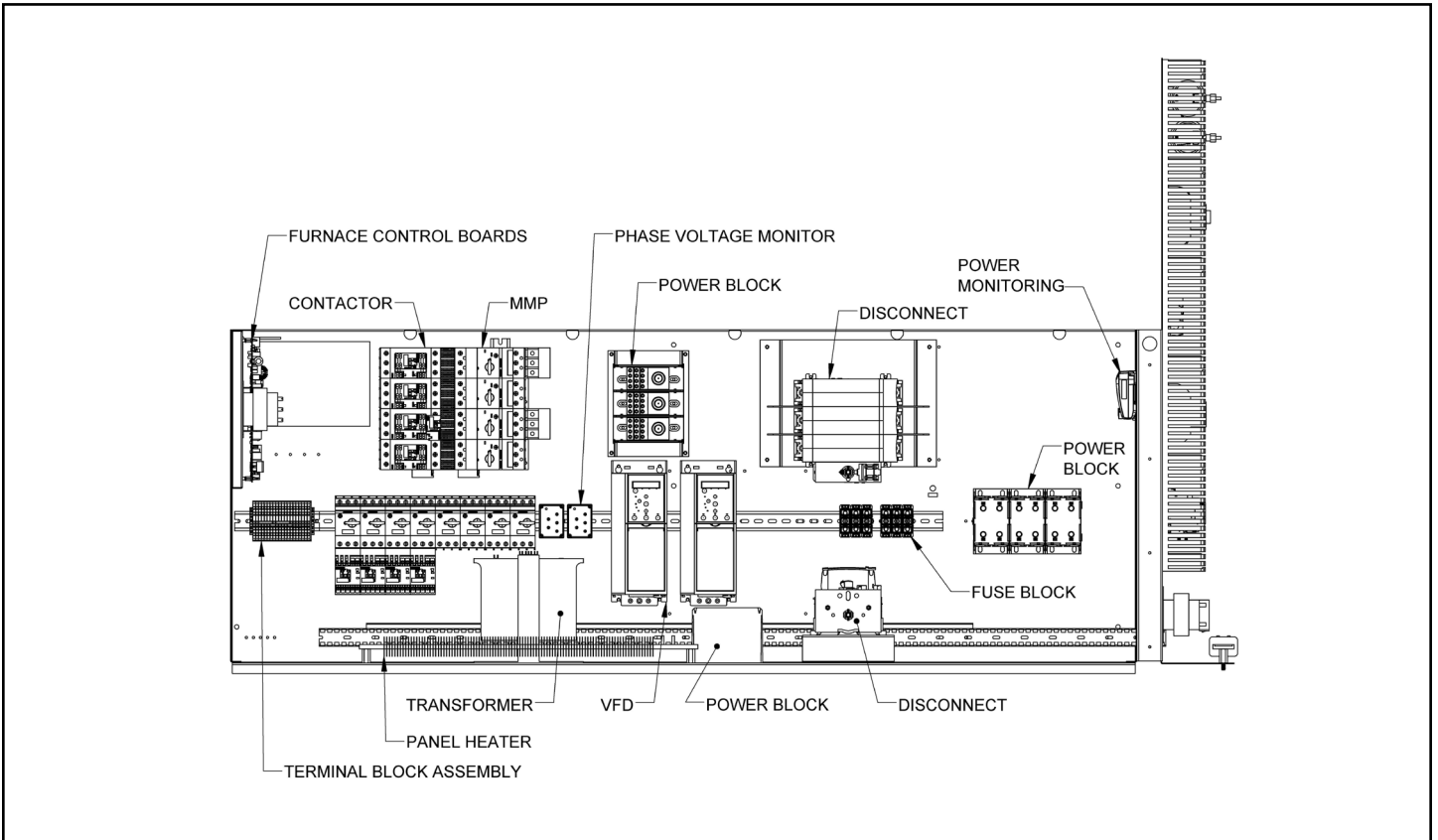
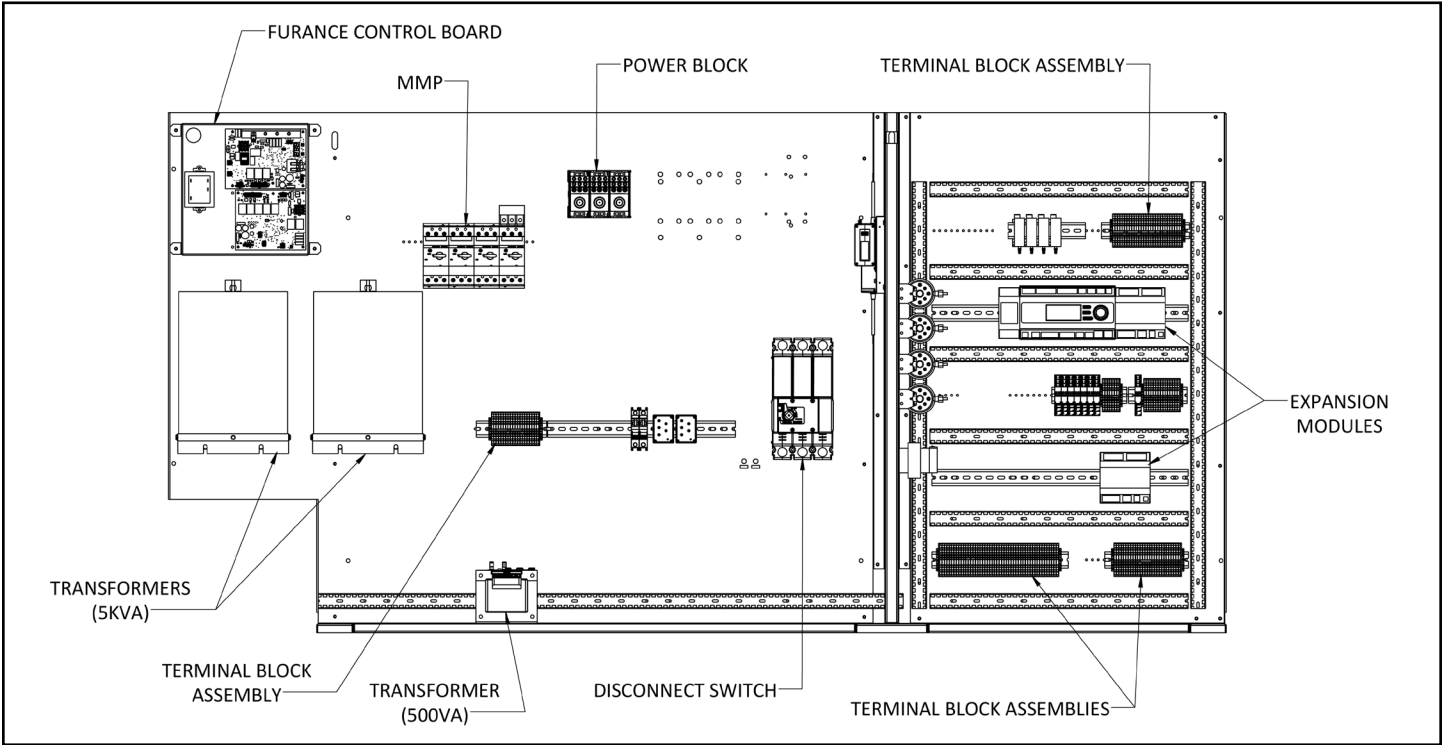


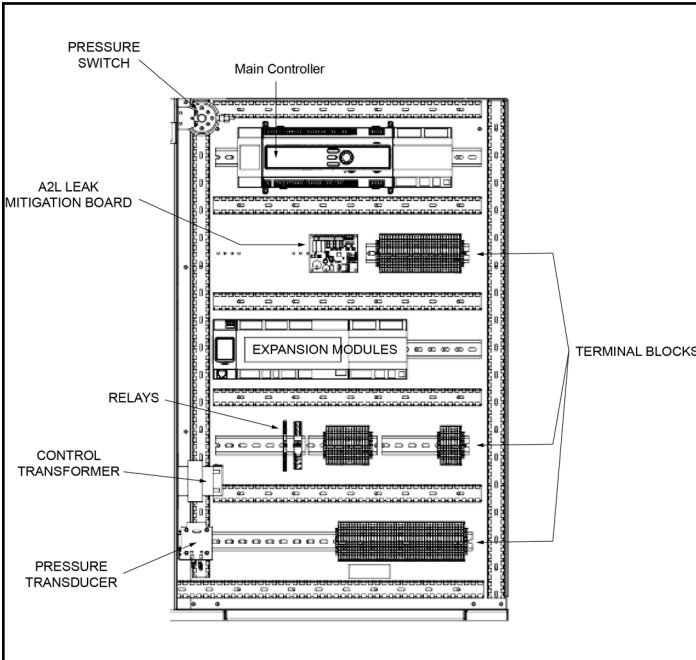
Figure 31: Typical Main High Voltage Electrical Panel (DPSA Unit)



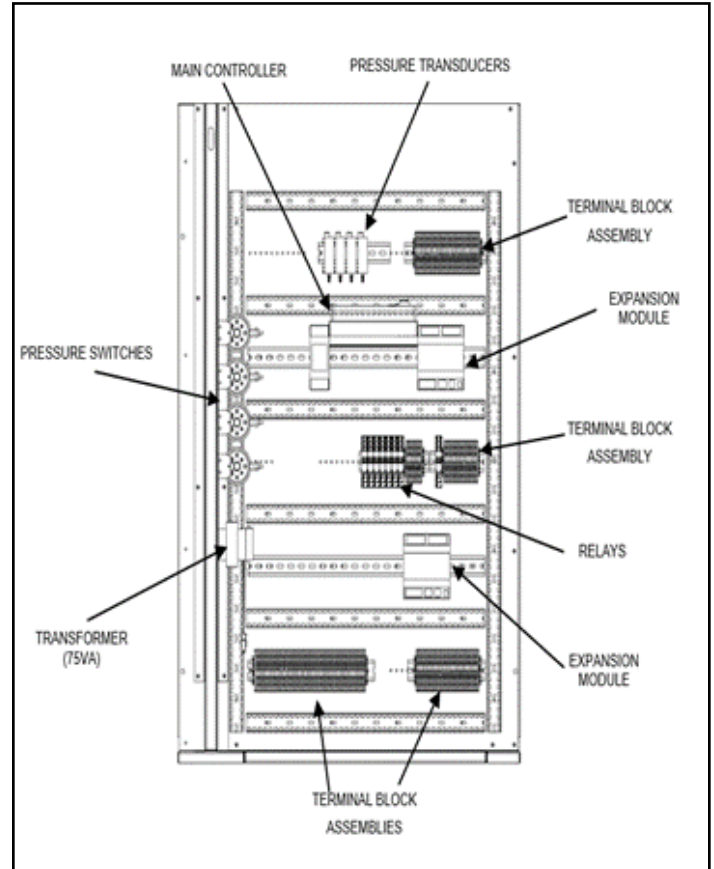
**Figure 32: Typical Main High Voltage Electrical Panel and Low Voltage Control Panel (DAHA Unit)**



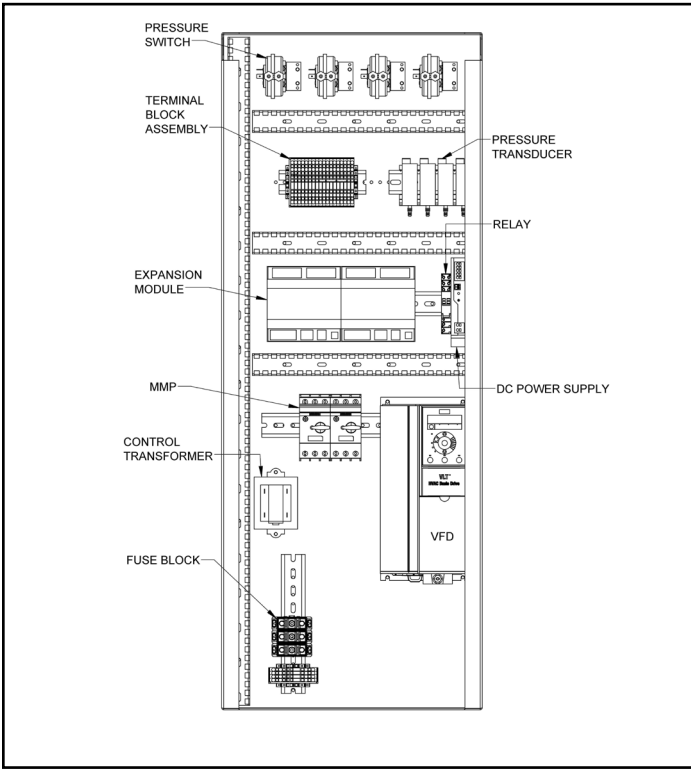
**Figure 33: Typical Low Voltage Control Panel (DPSA Unit)**



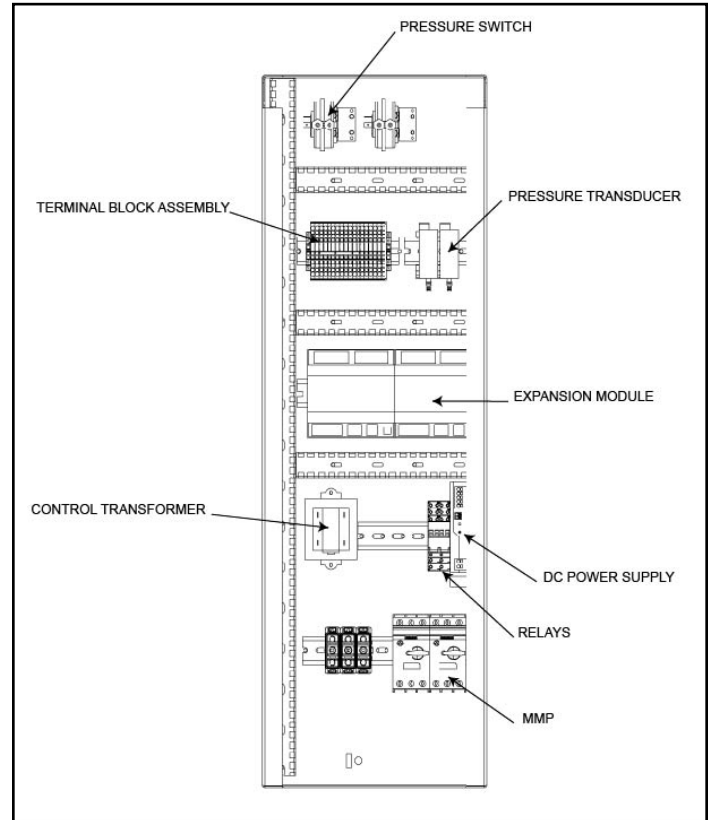
**Figure 34: Typical Low Voltage Control Panel (DAHA Unit)**



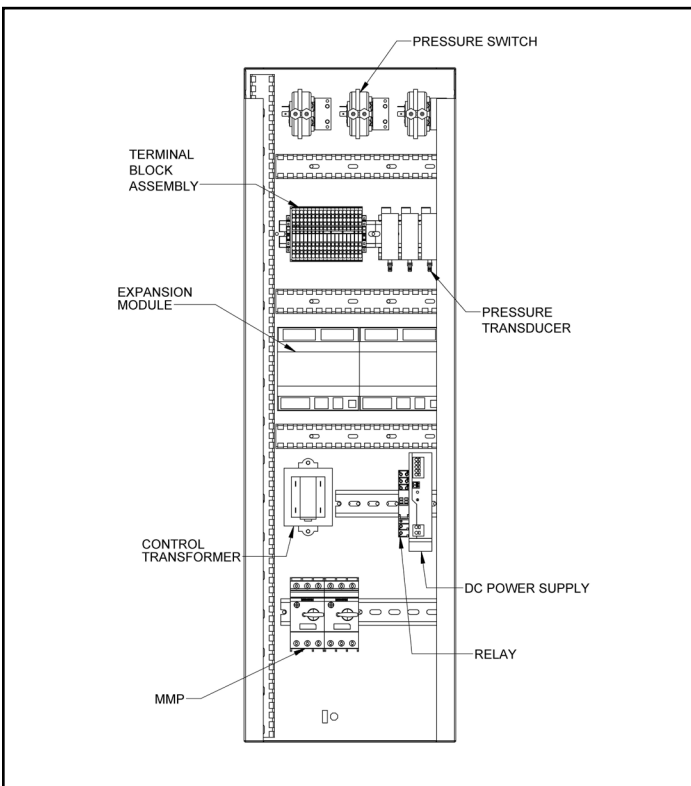
**Figure 35: Typical Return Control Panel (with Prop Exhaust Fan VFD)**



**Figure 37: Typical Return Control Panel (with Energy Recovery Wheel)**



**Figure 36: Typical Return Control Panel (without Prop Exhaust Fan VFD)**



# Installation

**WARNING**

Sharp edges on sheet metal and fasteners can cause personal injury. Always wear appropriate personal protective equipment (PPE) such as gloves, protective clothing, footwear, eye protection, etc. This equipment must be installed, operated, and serviced only by an experienced installation company and fully trained personnel.

The installation of this equipment shall be in accordance with the regulations of authorities having jurisdiction and all applicable codes. It is the responsibility of the installer to determine and follow the applicable codes.

**NOTICE**

Unit/equipment must be installed in a location that is not accessible to the general public.

## Receiving and Handling

Carefully check equipment against the bill of lading to ensure all items have been received. Before unloading any unit, check the nameplate to make sure the voltage complies with the power supply available.

Inspect all units for damage upon arrival. If a unit has become dirty during shipment, carefully clean it prior to completing the inspection. Daikin Applied is not responsible for physical damage after the unit leaves the factory unless the contract with Daikin Applied states otherwise.

**NOTICE**

All units should be carefully inspected for damage when received. Report all loss or shipping damage using a claim form supplied by Daikin Applied.

**VISIBLE LOSS OR DAMAGE:** Any external evidence of loss or damage must be noted on the freight bill or carrier's receipt, and signed by the carrier's agent. Failure to adequately describe such external evidence of loss or damage may result in the carrier's refusal to honor a damage claim.

**CONCEALED LOSS OR DAMAGE:** Concealed loss or damage means loss or damage which does not become apparent until the unit has been unpacked or unwrapped. The contents may be damaged in transit due to rough handling even though the exterior may not show damages. When the damage is discovered, make a written request for inspection by the carrier's agent within **five (5) days** of the delivery date and file a claim with the form provided by Daikin Applied. Refer to the Daikin Applied Freight Policy for further information.

## Compliance Statements

Depending on the unit configuration, the unit will come with either a Fused Disconnect, a Non-Fused Disconnect, a power block, or a combination in cases where multiple sources of power are specified. Consult the Unit Specific Electrical Schematics to determine the number of required sources of power. Refer to [page 71](#) for the standard multiple point power connection options and their function.

Children should be supervised to ensure that they do not play with the appliance.

This appliance is not intended for use by persons (including children) with reduced physical, sensory, or mental capabilities, or lack of experience and knowledge, unless they have been given supervision or instruction concerning use of the appliance by a person responsible for their safety.

## Unit Clearances

### Service Clearance

Allow service clearance as indicated in [Figure 38](#) or [Figure 39](#). [Figure 38](#) denotes clearances required if large component replacement would be completed through side access doors. [Figure 39](#) denotes clearances needed if large component replacement would be completed from the top of the unit (with a crane) after removing roof panels. Also, Daikin Applied recommends providing a walkway around the entire unit for access to controls and serviceable components.

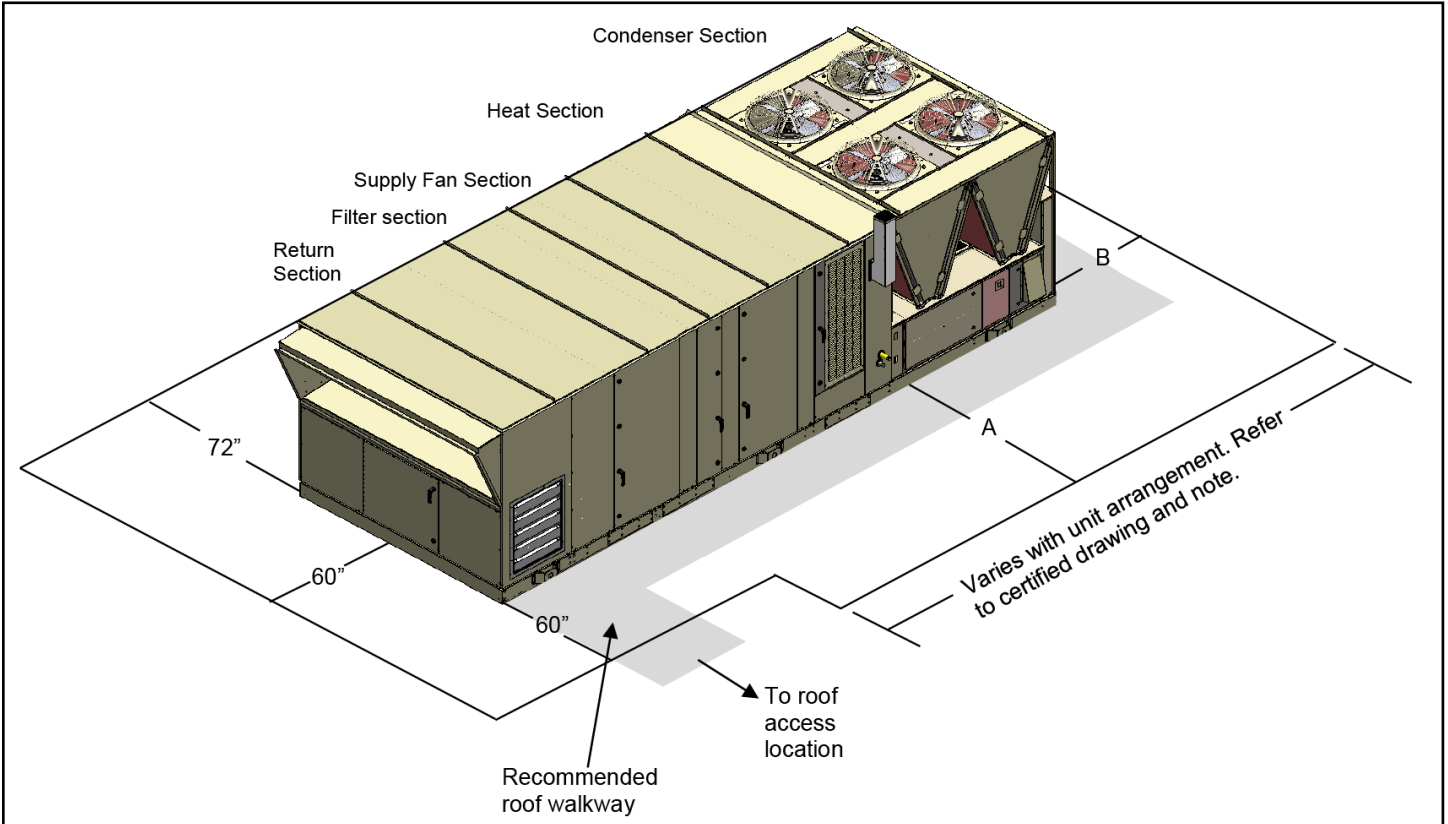
**Table 2: DPSA Unit Service Clearances by Unit Size (see [page 29](#))**

DPSA Cabinet Configuration	A Dimension	B Dimension
A Cooling	96	60
B Cooling	96	60
B Standard Output Heat Pump	96	100
B High Output Heat Pump	96	100
C Cooling	96	100
C Heat Pump	96	100
D Cooling	120	72
E Cooling	144	72

**Table 3: DAHA Unit Service Clearances by Unit Size (see [page 30](#))**

DAHA Cabinet Configuration	A Dimension	B Dimension
B Cooling	96	48
C Cooling	96	48
D Cooling	120	48

**Figure 38: DPSA/DHSA Unit Service Clearances (Scenario A)**



**Figure 39: DPSA/DHSA Unit Service Clearances (Scenario B)**

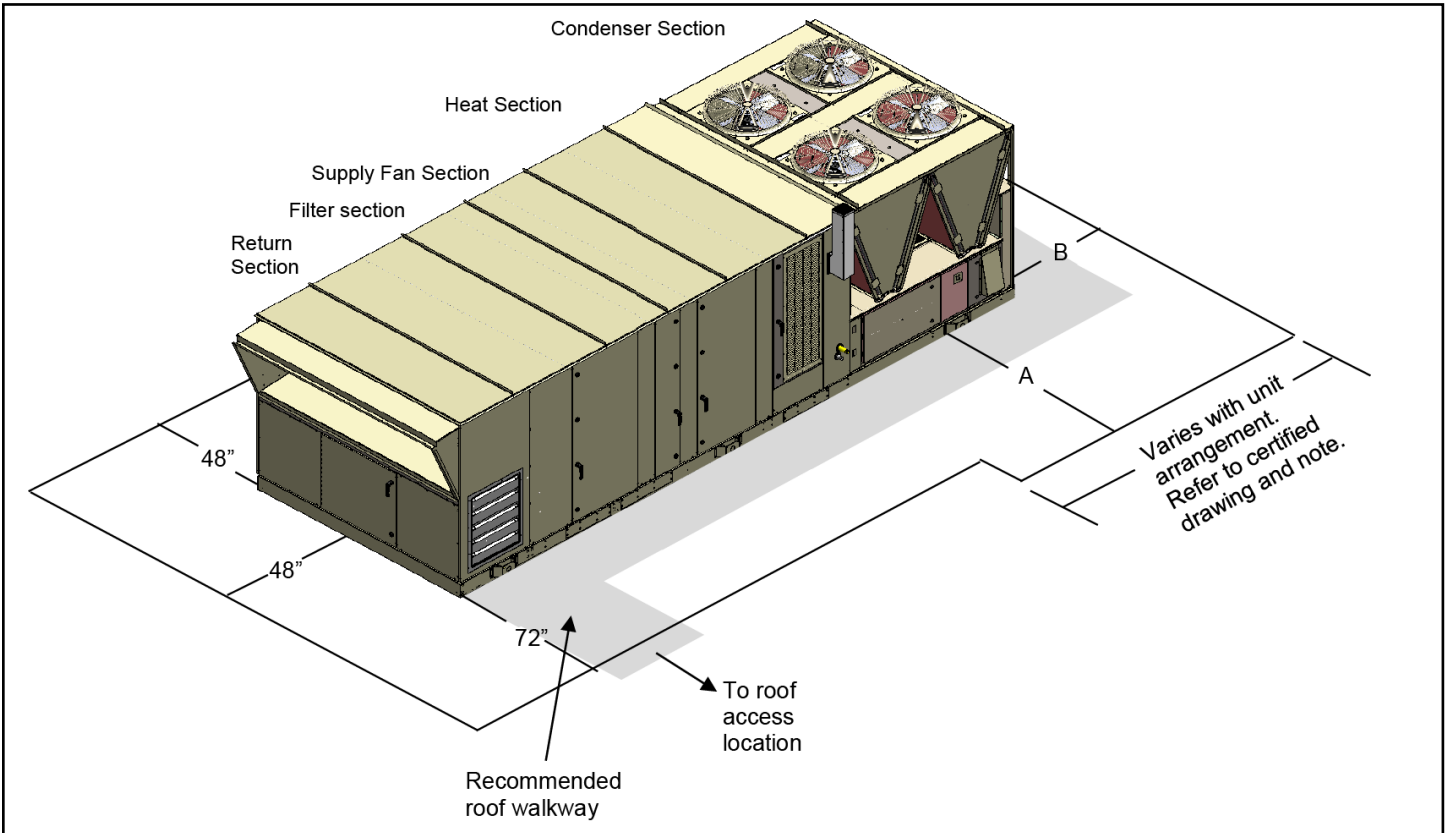


Figure 40: DAHA Unit Service Clearances (Scenario A)

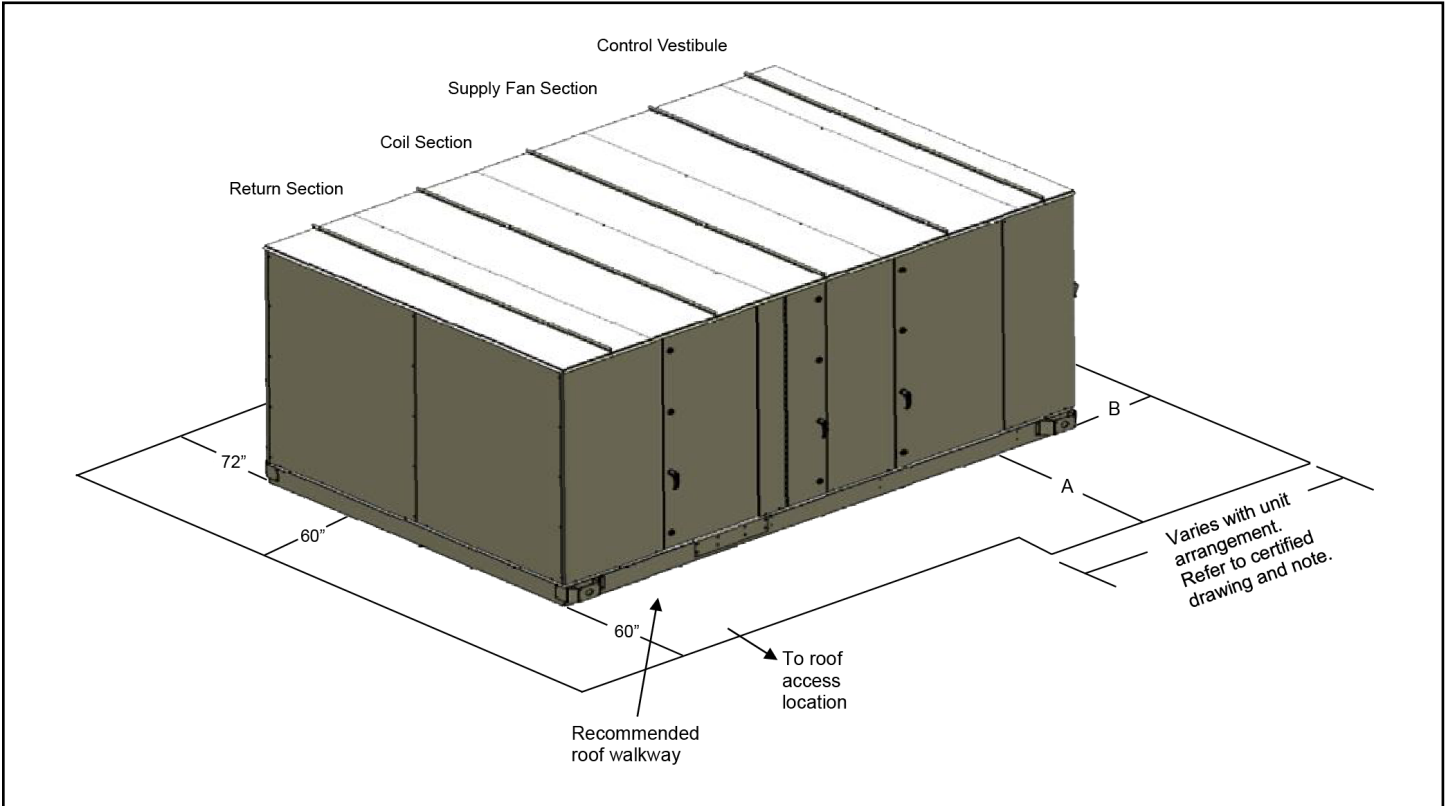
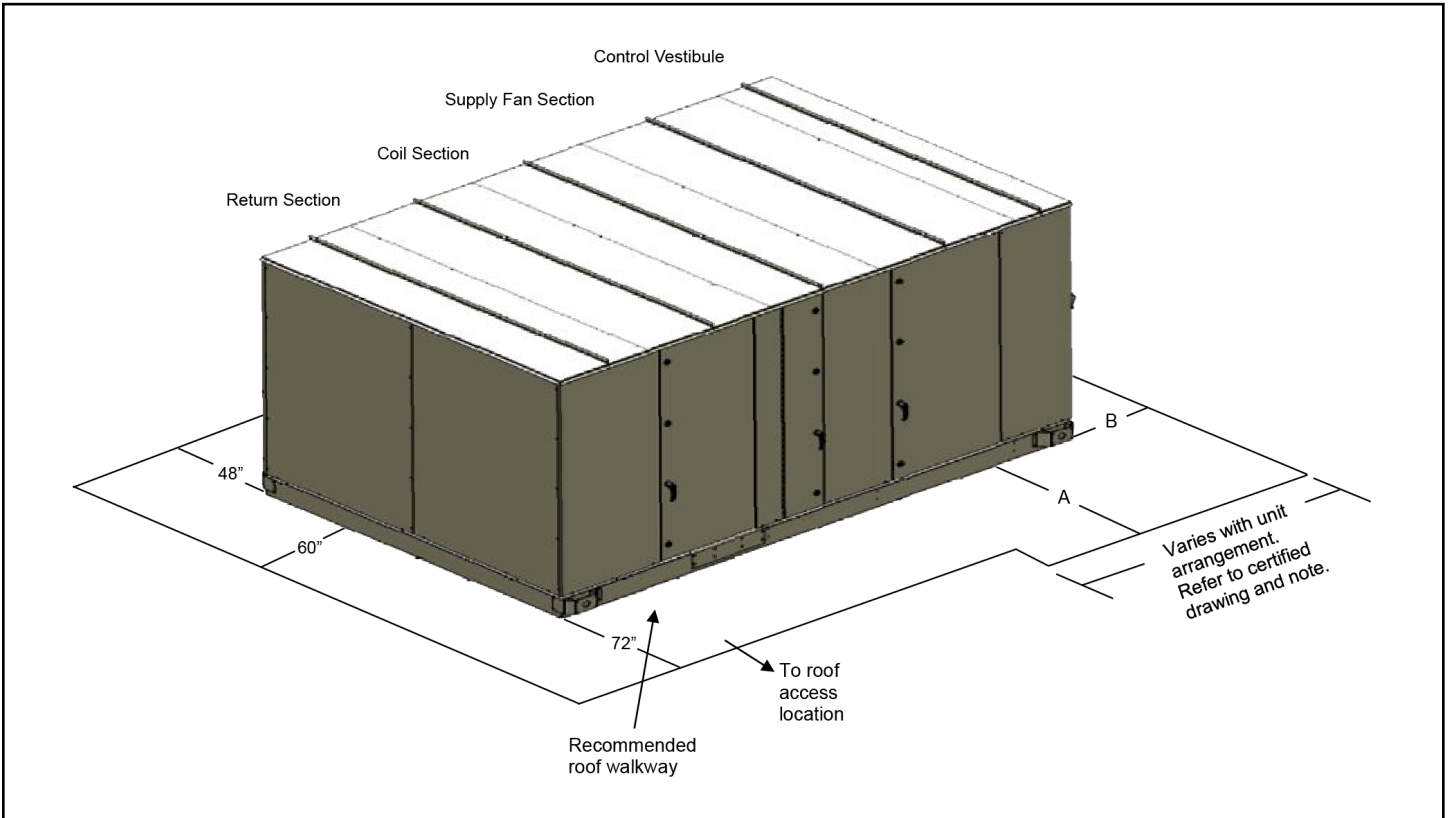


Figure 41: DAHA Unit Service Clearances (Scenario B)



## Ventilation Clearance

Figure 42 denotes minimum ventilation clearance recommendations. The system designer must consider each application and provide adequate ventilation. If this is not done, the unit will not perform properly.

### NOTICE

Units equipped with furnace flues should have no overhead obstructions. There should also be no obstructions within 9 in of the flue in any other direction.

### Unit(s) Surrounded by a Screen or a Fence:

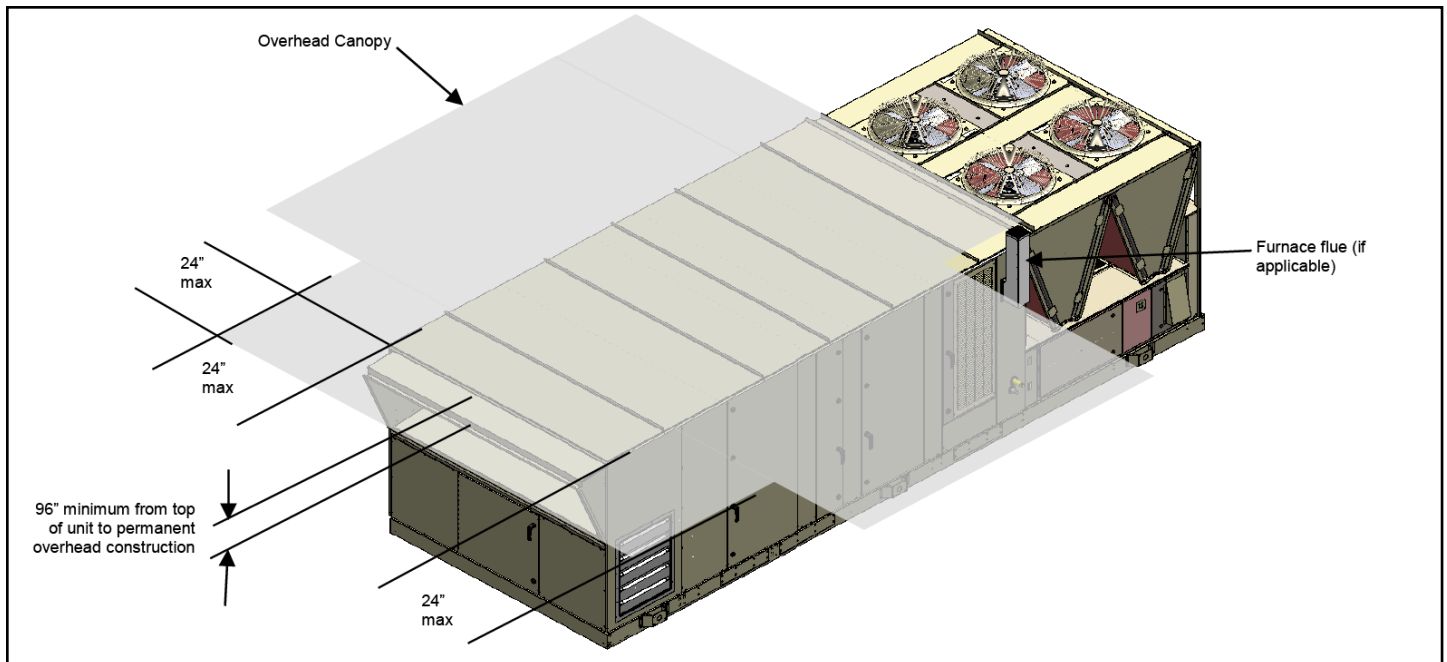
1. The bottom of the screen or fence should be at least 1 ft. (305 mm) above the roof surface.
2. The distance between the unit and a screen or fence should be as described in (Figure 38 or Figure 39 on page 29).
3. The distance between any two units within a screen or fence should be at least 120" (3048 mm).

### Unit(s) Surrounded by Solid Walls:

1. If there are walls on one or two adjacent sides of the unit, the walls may be any height. If there are walls on more than two adjacent sides of the unit, the walls should not be higher than the unit.
2. The distance between the unit and the wall should be at least 96" (2438 mm) on all sides of the unit.
3. The distance between any two units within the walls should be at least 120" (3048 mm).

Do not locate outside air intakes near exhaust vents or other sources of contaminated air.

Figure 42: Overhead Clearance



If the unit is installed where windy conditions are common, install wind screens around the unit, maintaining the clearances specified (Figure 38 or Figure 39 on page 29). This is particularly important to prevent blowing snow from entering outside air intake and to maintain adequate head pressure control when mechanical cooling is required at low outdoor air temperatures.

## Overhead Clearance

### WARNING

Obstructions above models equipped with heat pump technology could result in the formation of icicles in colder ambient temperatures. Do not examine, operate, or service the unit if icicle formations are present above the unit, as serious injury or property damage may occur.

1. If clearances from Scenario B (Figure 39 on page 29) are applied to the installation, then unit must not have any overhead obstructions over any part of the unit.
2. If unit is surrounded by solid walls or screens, then unit must not have any overhead obstructions over any part of the unit.
3. The area above the condenser must be unobstructed in all installations to allow vertical air discharge.
4. The following restrictions must be observed for overhead obstructions above the air handler section where ground clearances noted in scenario A are applied (i.e. if Figure 38 on page 29 or Figure 40 on page 30 is applicable, then Figure 42 shows allowable overhead canopy):
  - a. Overhead obstructions must be no less than 96" (2438 mm) above the top of the unit.
  - b. There must be no overhead obstructions in the areas above the outside air intake and exhaust dampers that are farther than 24" (610 mm) from the side of the unit.

## Roof Curb Assembly and Installation

### WARNING

Mold can cause serious illness and property damage. Some materials such as gypsum wall board can promote mold growth when damp. Such materials must be protected from moisture that can enter units during maintenance or normal operation.

Locate the roof curb and unit on a portion of the roof that can support the weight of the unit. The unit must be supported to prevent bending or twisting of the machine.

If building construction allows sound and vibration into the occupied space, locate the unit over a non-critical area. **It is the responsibility of the system designer to make adequate provisions for noise and vibration in the occupied space.**

Install the curb and unit level to allow the condensate drain to flow properly and allow service access doors to open and close without binding.

**NOTE:** It is critical that the condensate drain side of the unit be no higher than the opposite side.

Integral supply and return air duct flanges are provided with the DPSA factory-provided roof curb, allowing connection of duct work to the curb before the unit is set.

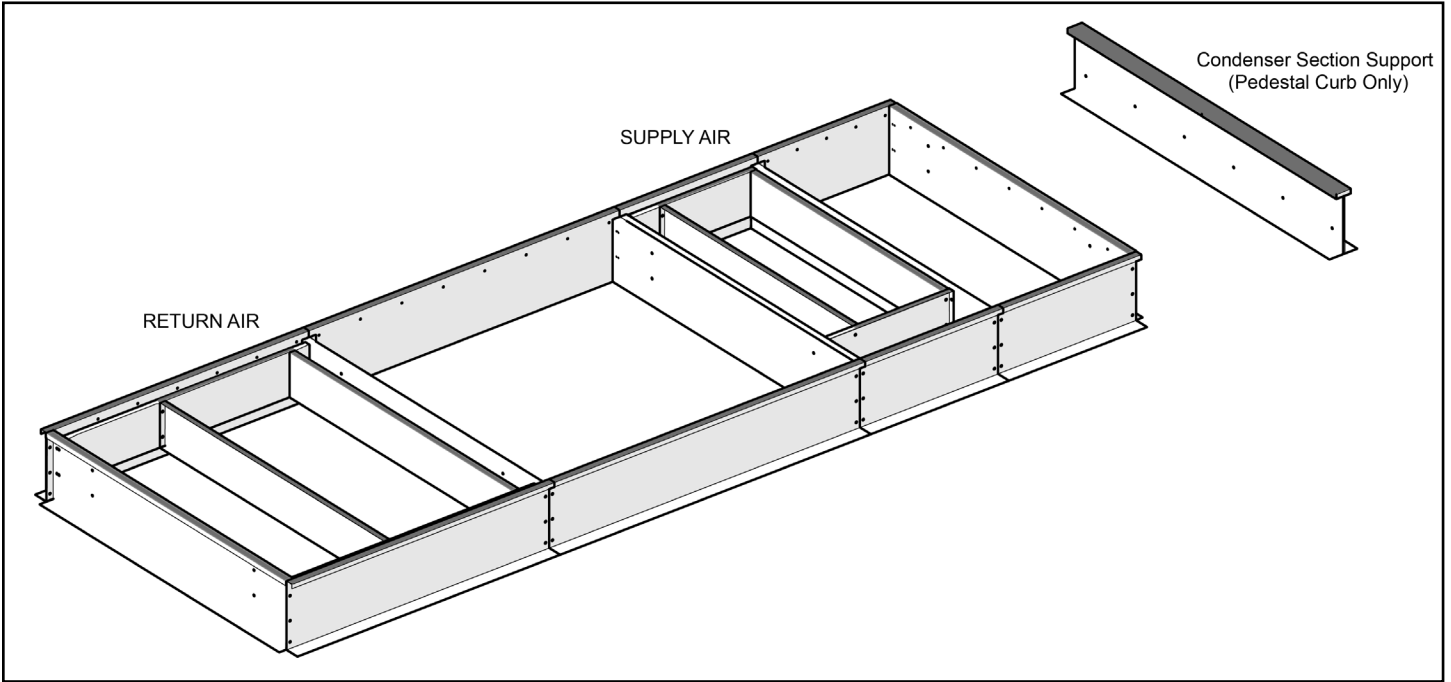
The gasketed top surface of the duct flanges seals against the unit when it is set on the curb.

These flanges must not support the total weight of the ductwork. Assembly of a typical DPSA roof curb is shown in [Figure 43](#). Assembly of a typical DPSA plenum curb is shown in [Figure 44](#) and can also have a full perimeter variation.

### **Curb Assembly instructions**

1. Set curbing parts in accordance with assembly instructions provided with unit. Take careful note of the location of return and supply air openings or plenum divider. Refer to submittal drawing for order-specific details.
2. If applicable, set other curbing parts in place making sure that the orientation complies with the assembly instructions. Check alignment of all mating bolt holes. See [Figure 45, Detail A](#).
3. Bolt curbing parts together using fasteners provided. Tighten all bolts finger tight.
4. Square entire curbing assembly and securely tighten all bolts.
5. Position curb assembly over roof openings. Curb must be level from side to side and over its length. Check that top surface of the curb is flat with no bowing or sagging.
6. Weld curbing in place. Caulk all seams watertight. Remove backing from 0.25" (6 mm) thick × 1.50" (38 mm) wide gasketing and apply to surfaces shown by the shaded areas in [Figure 43](#) and [Figure 44](#) on page 33.
7. Flash curbing into roof as shown in [Figure 45, Detail A](#).
8. Be sure that electrical connection are coordinated (see [Figure 47](#)).

**Figure 43: Typical Bottom-Ducted Roof Curb Assembly**



**Figure 44: Typical Plenum Curb Assembly**

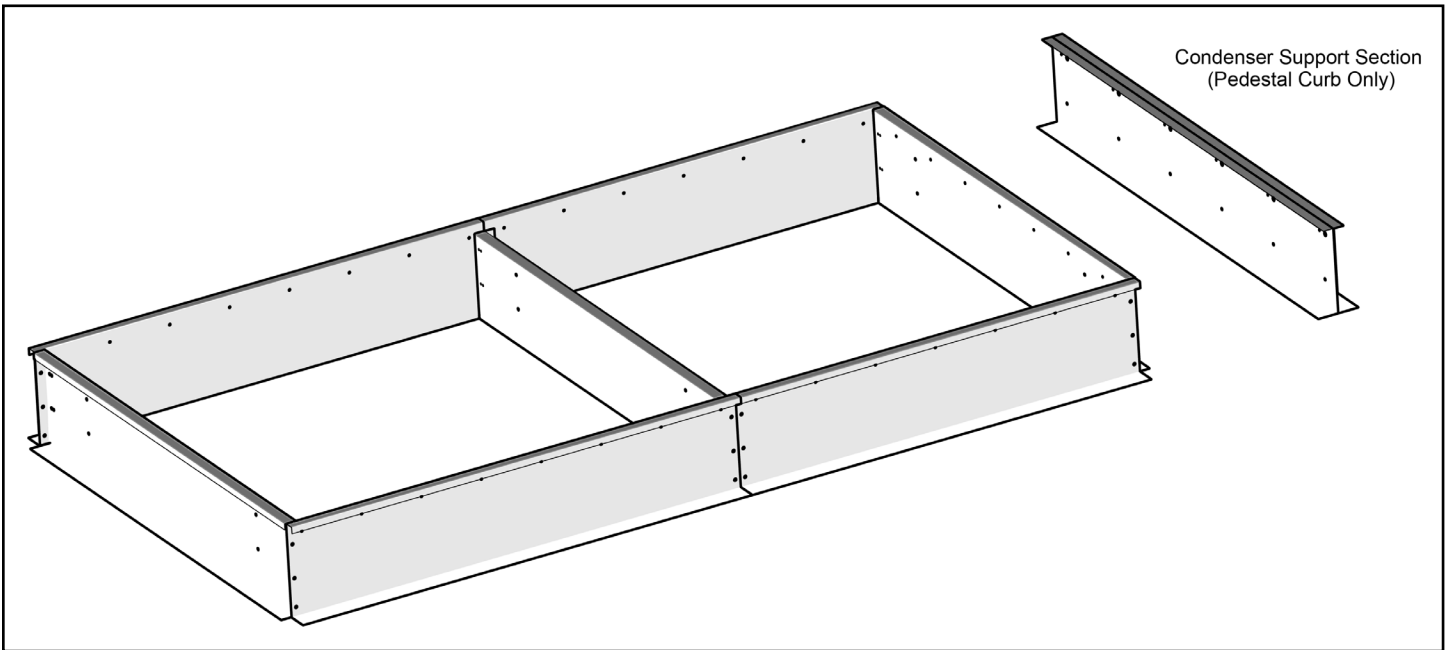
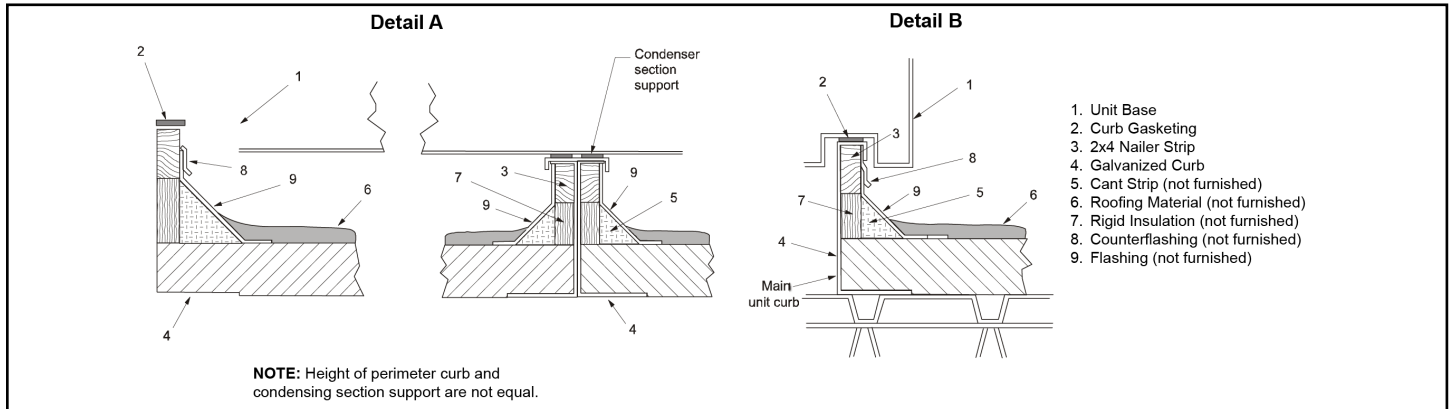
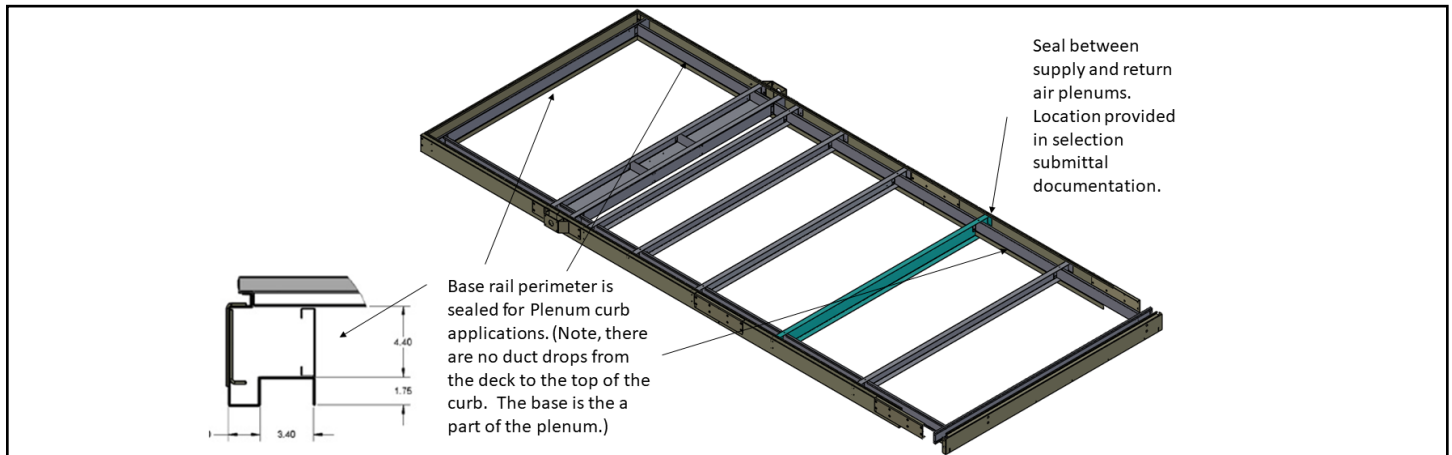


Figure 45: Detail Views



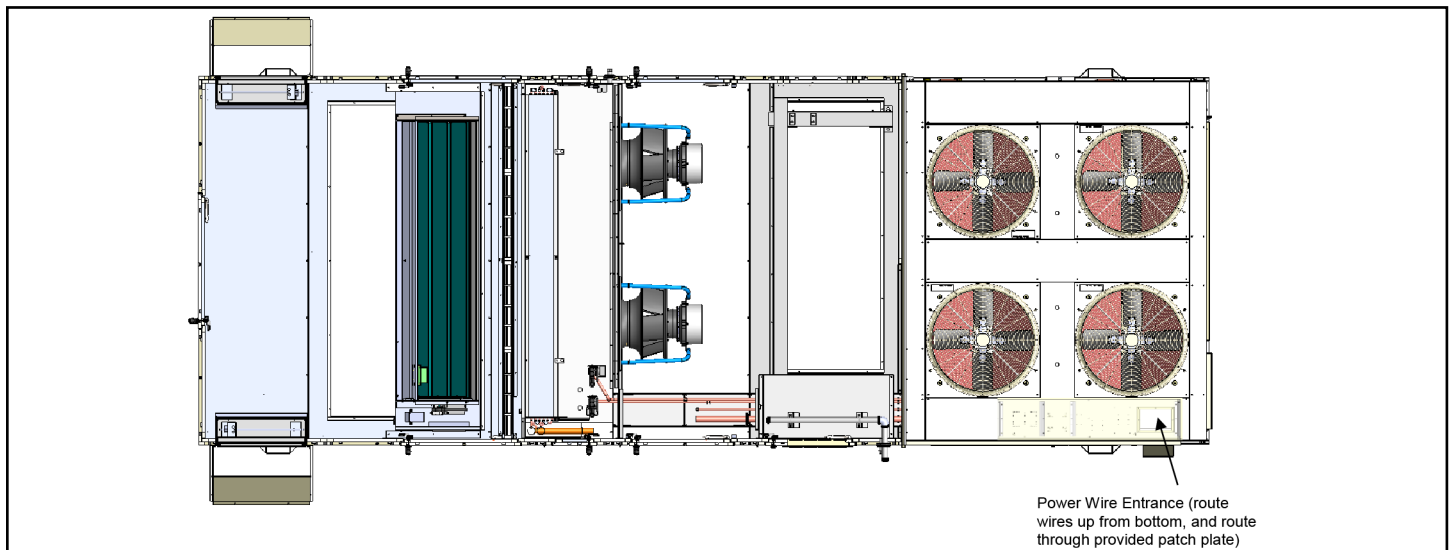
## Curb Assemblies

Figure 46: Plenum Curb Intermediate Steel Structure Member and Cross Section Details



The base of the unit has structural steel between the floor of the unit and the curb sealing surface. For plenum curb applications, extra insulation and sealing is required. Consult the factory before application with a plenum curb.

Figure 47: Typical Power Wire Entrance, Curb View, See Project Certified Drawings



**NOTE:** Dimensions Q and R can be found in unit documentation (submittal).

## Wiring With Full Perimeter Curbs

### NOTICE

Insulated condenser floors are provided when full perimeter roof curb support is selected. All penetrations made through full condenser floor models must be sealed to prevent leaks. Failure to do so could result in property damage.

#### Notes before following this procedure:

- Read through these instructions completely before starting work on the unit.
- These instructions assume the unit has been properly placed and there is adequate room to work below the unit for building conduit connections.
- These instructions assume component selections are appropriately sized. The installer must determine the correct hole sizes based on component selections.
- These instructions apply to Rebel Applied Full Floor Condenser type units.
- Each penetration will require a:
  - conduit hub
  - pipe nipple
  - lock nut
  - conduit flange plate
  - conduit coupler

#### 1. Access, Measure, and Drill

- Open the door to the main control panel section and locate the main panel plate. Remove the fasteners holding the main panel plate in position to access the condenser floor (DPSA unit shown).

Figure 48: Main High Voltage Electrical Panel

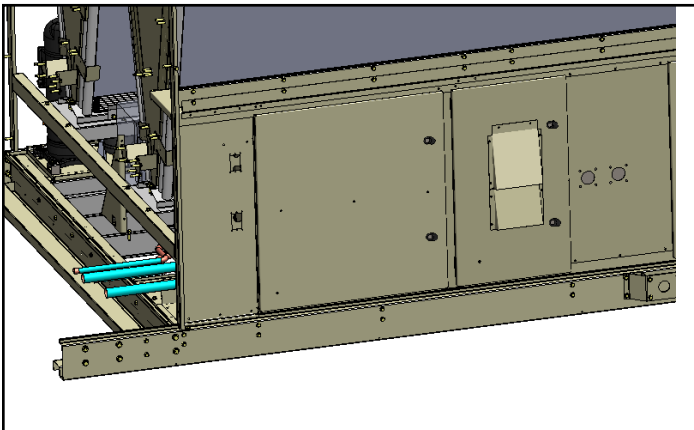


Figure 49: Main Panel Plate Location

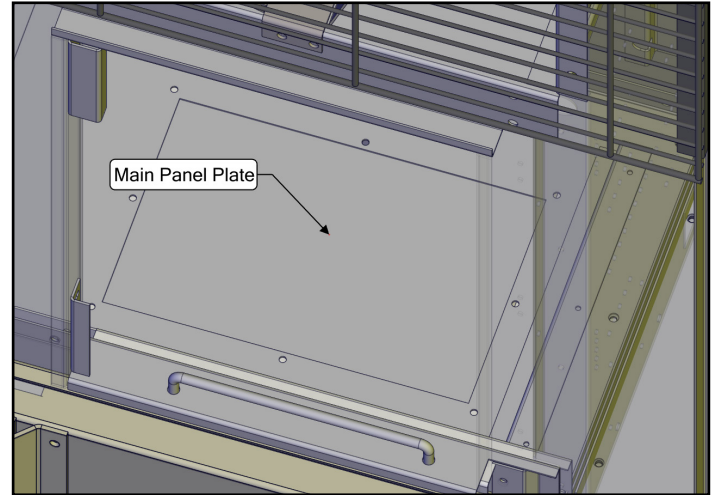
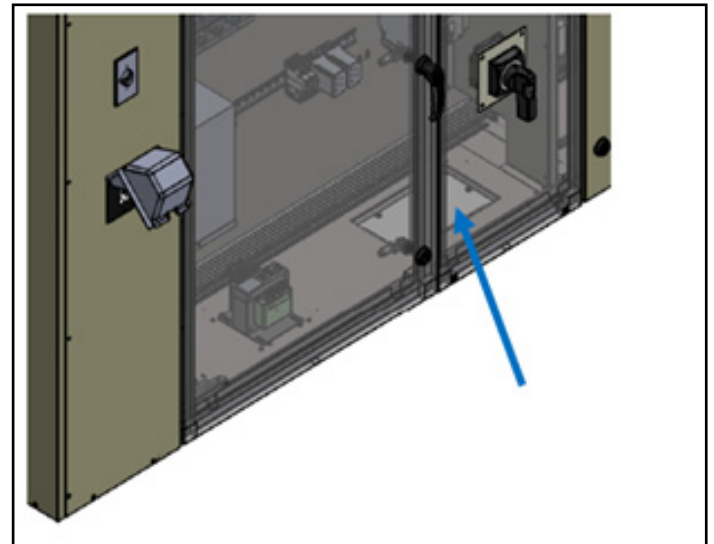


Figure 50: DAHA Unit Panel Plate Example

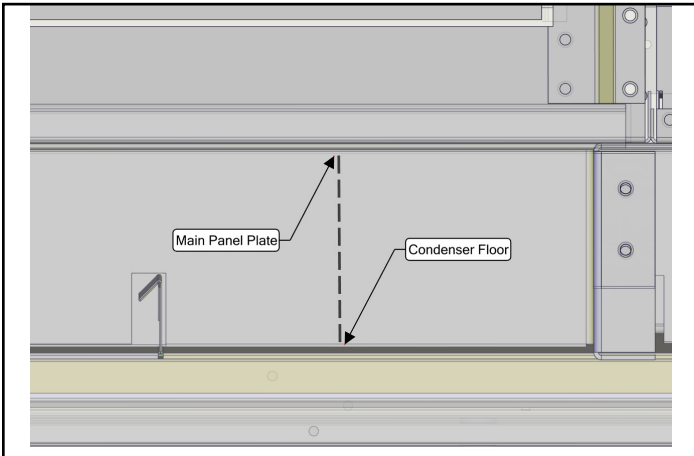


- Identify the correct placement for drilling holes in the main panel plate and the condenser floor.
- Drill concentric holes in the main panel plate and the condenser floor based on the selected conduit hub and pipe nipple.

#### 2. Measure

- Place the main panel plate back into position.
- Measure the distance from the bottom of the plate to the top of the condenser floor (retain this measurement for building the assembly).
- Remove the main panel plate.

**Figure 51: Condenser Floor and Main Panel Plate Measurement**

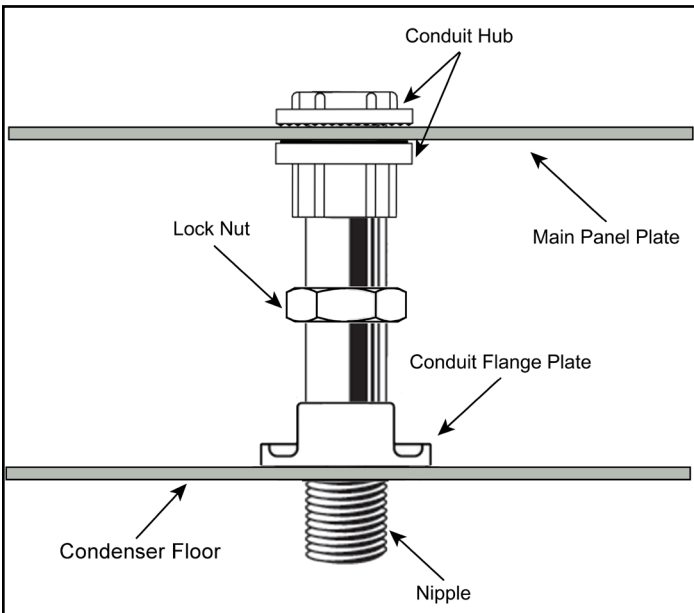


**3. Build Assembly**

- Spin the conduit flange plate onto the pipe nipple.
- Spin the lock nut onto the pipe nipple.
- Firmly attach the pipe nipple to the bottom of the conduit hub.
- Remove the top of the conduit hub to place the main panel plate into position.
- Hand tighten the top of the conduit hub to the main panel plate.
- Spin the conduit flange so that the bottom of the flange is the correct distance from the main panel plate using the measurement made previously in Step 3 (bottom of plate to top of condenser floor).

**NOTE:** It is better for conduit flange placement to be too long than too short.

**Figure 52: Assembly Components**



**4. Check Placement**

- Place assembly into position.
- Ensure that the conduit flange plate is resting on the condenser floor.
- It is acceptable for the main panel plate to be slightly above the bottom of the main control panel (no more than 1/8 in.). This will help when creating the final seal.

**5. Prepare for Sealing**

- Remove the assembly from position and remove the top of the conduit hub to remove the main panel plate.
- Place the assembly back into position.

**6. Measure and Drill**

- Mark and drill the top of the condenser floor to create fastener holes for the conduit flange plate.

**NOTE:** There are two layers of 0.022 in. steel sheet metal that need to be drilled through. Between this steel is the foam insulation of the panels.

**7. Seal with Caulk**

- Remove the assembly from position.
- Make a complete bead of caulk around the pipe nipple hole and each of the fastener holes drilled for the conduit flange plate. This will help prevent water from entering the building.

**8. Align Assembly**

- Lower assembly into the condenser floor penetration, aligning the holes in the conduit flange plate to the holes in the condenser floor.

**9. Secure Conduit Flange Plate**

**NOTICE**

Do not use excessive force when tightening fasteners, or they will strip.

- Secure the conduit flange plate to the condenser floor using the correct size fasteners. Screw **BY HAND** to snug the fasteners to the condenser floor.

**10. Fix Position**

- Spin the lock nut downward and snug to the conduit flange plate.

**NOTE:** Do not allow the nipple to spin while doing this.

**11. Repeat Steps 1-10 for Additional Penetrations**

- As necessary, repeat Steps 1-10 for additional electrical penetrations.
- Steps 12-14 define the final instructions necessary to complete each electrical penetration.

**12. Position and Secure Main Panel Plate**

- Position the main panel plate over the conduit hub.
- Tighten the top of the conduit hub to the assembly.

**13. Finalize Assembly**

- Attach a conduit coupler to the bottom of the pipe nipple for each assembly.
- The unit is now ready to have the building conduit attached and wire pulled.

## Post and Rail Mounting

**⚠ WARNING**

The unit must be level side to side and over the entire length. Equipment damage can result if the unit is not level.

**⚠ WARNING**

Lifting points may not be symmetrical to the center of gravity of the unit. Ballast or unequal cable lengths may be required.

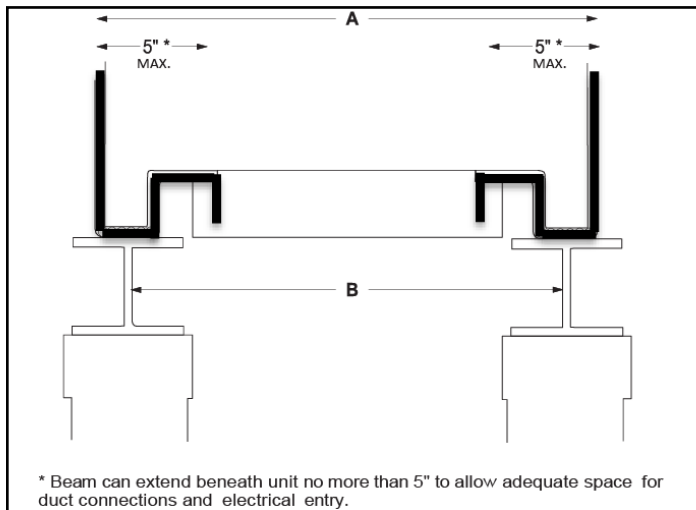
**⚠ CAUTION**

Use all lifting points. Improper lifting can cause injury, death, and property damage.

When mounting by post and rail, run the structural support the full length of the unit. Locate the structural member at the base of the unit as shown in [Figure 53](#), assuring the structural steel is well supported by the structural member.

If resilient material is placed between the unit and the rail, insert a heavy steel plate between the unit and the resilient material to distribute the load. Seal cabinet penetrations (electrical, piping, etc.) properly to protect against moisture and weather.

**Figure 53: Post and Rail Mounting**



**Table 4: Post and Rail Mounting Dimensions**

Cabinet Size	Dimension A	Dimension B
A	96.5 in.	94.5 in.
B		
C		
D	123.1 in.	121.1 in.
E	138.1 in.	136.1 in.

## Lifting Guidance

Daikin Applied equipment is designed to withstand the loads of the lifting and rigging process resulting from ASME Standard P30.1 - Planning for Load Handling Activities or equivalent. Lifting guidance is intended for installations of newly delivered equipment. If moving previously installed equipment for re-location or disposal, consideration should be given to unit condition. Equipment should also be drained as unit weight and center of gravity values do not reflect the addition of water for lifting.

**⚠ DANGER**

Improper rigging, lifting, or moving of a unit can result in unit damage, property damage, severe personal injury, or death. See the as-designed, certified dimensioned drawings included in the job submittal for the weights and center of gravity of the unit. If the drawings are not available, consult the local Daikin Applied sales office for assistance.

Installation is to be performed only by qualified personnel who are familiar with local codes and regulations, and experienced with this type of equipment. Lifting equipment and mechanisms must be determined by the Lifting Director per the current version of ASME Standard P30.1 or equivalent and must be suited for the load capacity. Daikin Applied is not a licensed nor certified rigging specialist. Therefore it is the customer's responsibility to consult a certified rigging contractor to rig, lift, and move components and subcomponents properly and safely as needed.

**⚠ CAUTION**

Forklifts may not be used to lift or move Rebel Applied units as the method may result in unit damage.

**⚠ CAUTION**

When around sharp edges, wear appropriate Personal Protective Equipment (PPE), such as gloves, protective clothing, foot wear, eye protection, etc., to prevent personal injury.

### Lifting Brackets

Lifting bracket designs vary from product to product. Rules of engagement with the lifting brackets are the same regardless of the bracket type. For Rebel Applied units, a typical lifting bracket with 2" (51 mm) diameter holes found on the sides of the unit base are illustrated in Figure 54. See the as-designed certified drawings for specific lifting points on this product model.

Engagement with each bracket is to be as close to vertical as possible. The maximum allowable lift angle from the vertical is 30 degrees as shown in Figure 55. If the lift angle shifts beyond 30° from vertical on any of the lift points, the lift shall not proceed until a plan and rigging can be secured that will correct the angle of lift.

**WARNING**

The lifting angle must not go beyond 30 degrees from vertical or the unit can become unstable which may result in unit damage, property damage, severe personal injury, or death.

Figure 54: Illustration of Lifting Bracket and Allowed Angle for Lifting

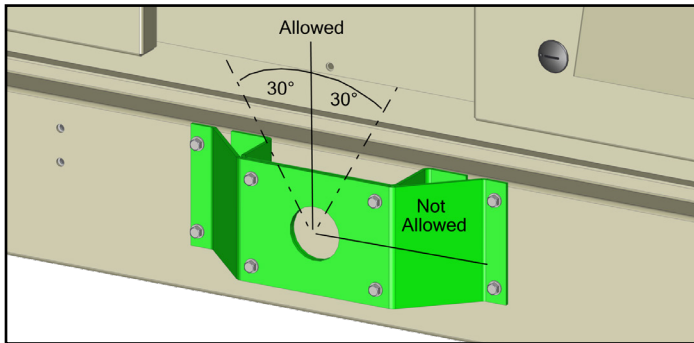


Figure 55: Example Illustrations of Allowed Angle Label

**WARNING**

**All factory provided lifting points must be used. Unit must remain level during lift and transit!**

The lifting and tie-down angle must not go beyond 30 degrees from vertical or the unit can become unstable which may result in unit damage, property damage or severe personal injury or death.

**WARNING**

**All factory provided lifting points must be used. Unit must remain level during lift and transit!**

The lifting strap angle must not go beyond 30 degrees from vertical or the unit can become unstable which may result in unit damage, property damage or severe personal injury or death.

**WARNING**

**All factory provided tie-down points must be used. Unit must remain level during transit!**

The tie-down strap angle must not go beyond 30 degrees from vertical or the unit can become unstable which may result in unit damage, property damage or severe personal injury or death.

### Lifting Equipment

Lifting equipment is supplied by the user or their designate. This is typically selected around the unit certified information of the equipment to be lifted and the available lifting equipment planned to be at the site where the lift is to take place. It is the responsibility of the Lifting Director to follow a standard practice of lift planning and equipment selection, like that found in the ASME P30 series of standards. Lifting plan and equipment must ensure that the only contact with the unit is at that lifting brackets. Straps, chains or spreader bars that are likely to be used shall not come in contact with the unit.

**⚠ CAUTION**

Lifting mechanisms must not make contact with the unit beyond the lifting bracket. Extreme care must be used when rigging the unit to prevent damage to the control panels, unit handles, unit piping, and unit frame.

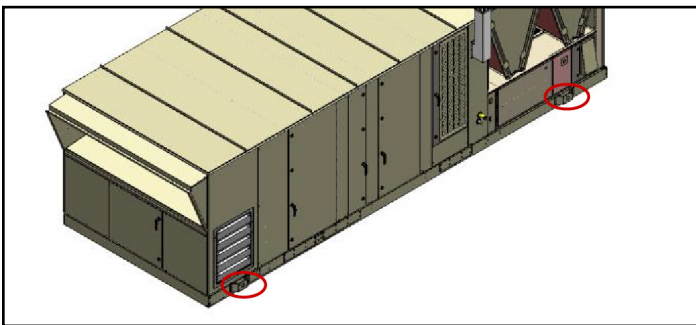
### Lifting Points

Lifting points are predetermined by design. When lifting, all factory installed lifting brackets must be used. Figure 56 illustrates typical 4 point and 6 point lifting configurations. Unit must remain level throughout the entire lifting event. Level is defined as one end being no more than 0.25 in. per foot of unit length to the opposite end.

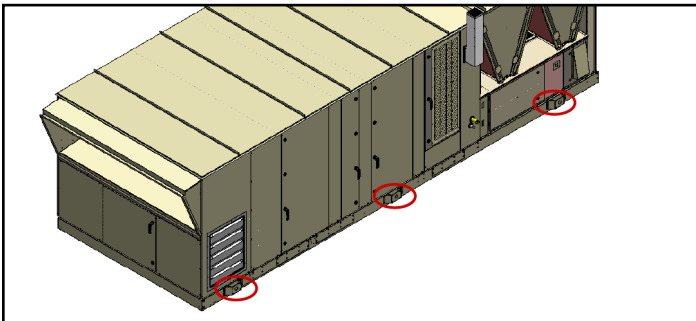
**⚠ WARNING**

Be aware that the center of gravity may not necessarily be in the geometric center of the unit. No additional items can be added to a lift with the unit as it may affect the center of gravity and cause unit damage, property damage, severe personal injury, or death. Refer to as-designed, certified drawings for weight, center of gravity location and details specific to unit configuration.

**Figure 56: Typical Lifting Points Locations (4 Lifting Points)**



**Figure 57: Typical Lifting Points Locations (6 Lifting Points)**



### Transit and Temporary Storage

If the unit is stored for an intermediate period before installation or moved to a different location, take these additional precautions:

1. Support the unit well along the length of the base rail.
2. Level the unit (no twists or uneven ground surface).
3. Provide proper drainage around the unit to prevent flooding of the equipment.
4. Provide adequate protection from vandalism, mechanical contact, etc.
5. Securely close the doors and lock the handles.
6. If there are isolation dampers, make sure they are properly installed and fully closed to prevent the entry of animals and debris through the supply and return air openings.
7. Cover the supply and return air openings on units without isolation dampers.
8. Long term storage in humid environments may cause condensate corrosion on steel surfaces. Consider adding a desiccant material to alleviate corrosion concerns.

When the unit is being tied down for transit, the maximum allowable attachment angle from the vertical is 30 degrees in the opposite direction of lifting in Figure 55. Shimming of the unit under the lifting brackets or tie-down points must be used to ensure even contact along the length of the base rail.

For more information on unit storage, refer to "Unit Storage" on page 127.

# Shipping Splits

## Reassembly of Shipping Splits

DPSA units are typically shipped complete, however, an optional configuration is available that allows for the unit to be split into 2 or 3 sections for easier shipping and handling. If this configuration is ordered, assembly of the split modules is required on site. Read and follow this instruction manual to ensure proper assembly and installation. A separate parts kit (Figure 58) will be shipped for each split in the cabinet. The kit contains the necessary components to reassemble the cabinet modules. The kit contents may differ from Figure 58 depending on the exact unit configuration and split location in the cabinet.

Figure 58: Kit for Reassembly of Shipping Splits

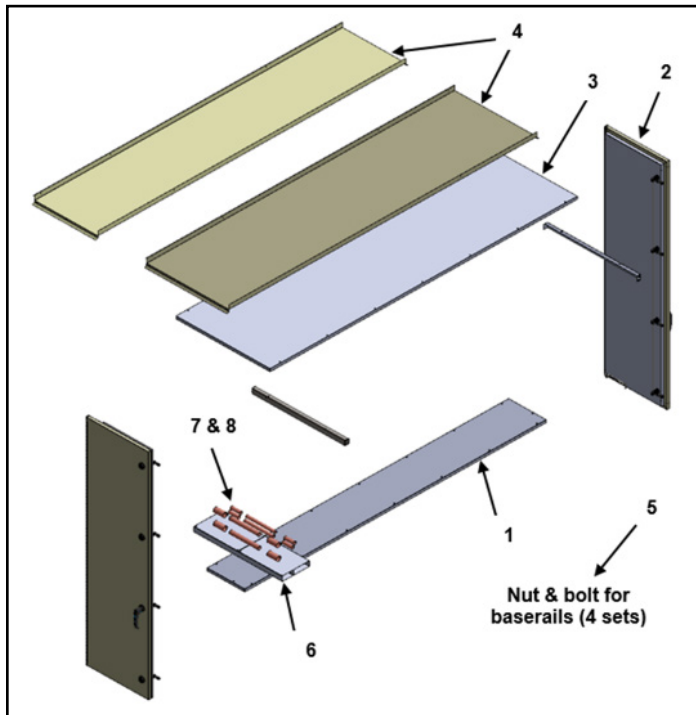
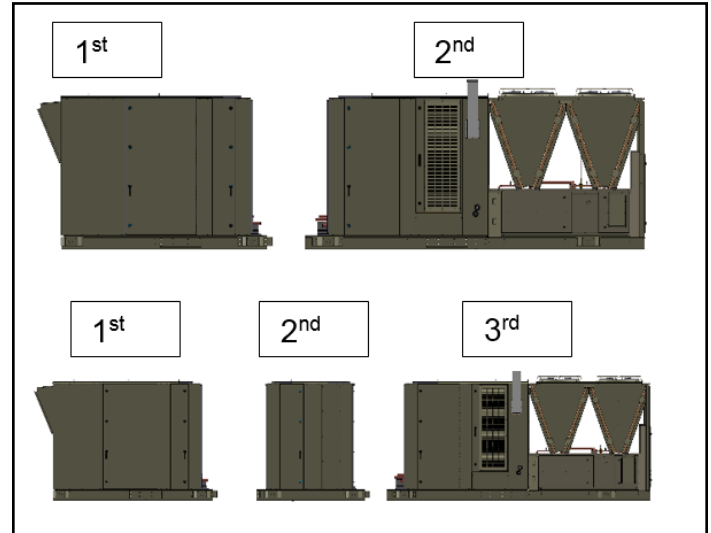


Table 5: Shipping Split Reassembly Kit

#	Components
1	2 in. deck panel (x1) (panel screws included)
2	2 in. doors (x2) (screws included for hinges)
3	2 in. roof panel (x1) (panel screws included)
4	Rain covers (x2) (hardware included)
5	Bolt, nut, and washer set for base rails (x4)
6	Parts for wire raceway
7	Up to 8 tubes
8	Up to 16 slip joints

The cabinet modules must be reassembled on the roof curb in the proper order. The return section should be set in place first, followed by the center section (if applicable), and the condenser section last (Figure 59).

Figure 59: Potential Split Locations and Order of Assembly on Curb

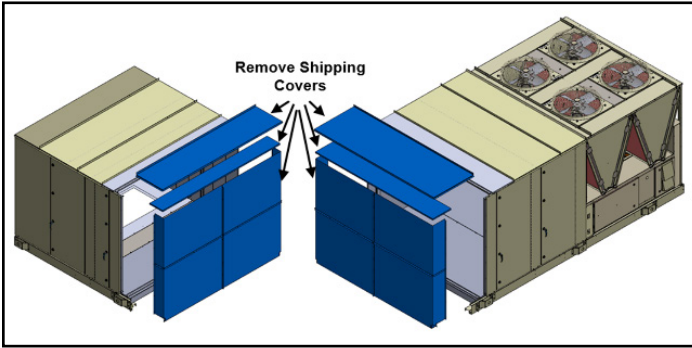


The instructions for setting and leveling the curb found in “Roof Curb Assembly and Installation” on page 32 must be followed to allow for the proper reassembly of the cabinet components. To ensure proper alignment and sealing of the cabinet panels it is critical that the curb is level and square before assembly.

## Reassembly Procedure

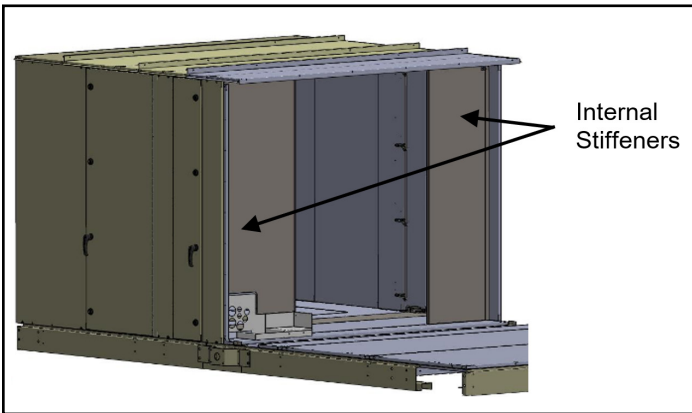
1. Always follow proper rigging and lifting procedures when moving the cabinet modules. See “Lifting Guidance” on page 37.
2. Remove the galvanized shipping covers. The open ends of the cabinet will be exposed once they are removed. The galvanized shipping covers will not be used during re-assembly and can be recycled. The cabinet will be resealed once the unit is reassembled using the supplied parts kit.

**Figure 60: Remove Shipping Covers**



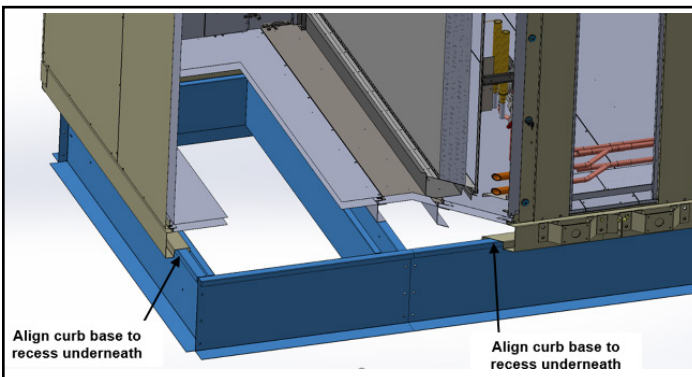
**NOTE:** Do not remove the Internal stiffeners at this time. They will help keep the cabinet square during the lift of the module to the roof curb (Figure 61).

**Figure 61: Do Not Remove Stiffeners Before Lift**



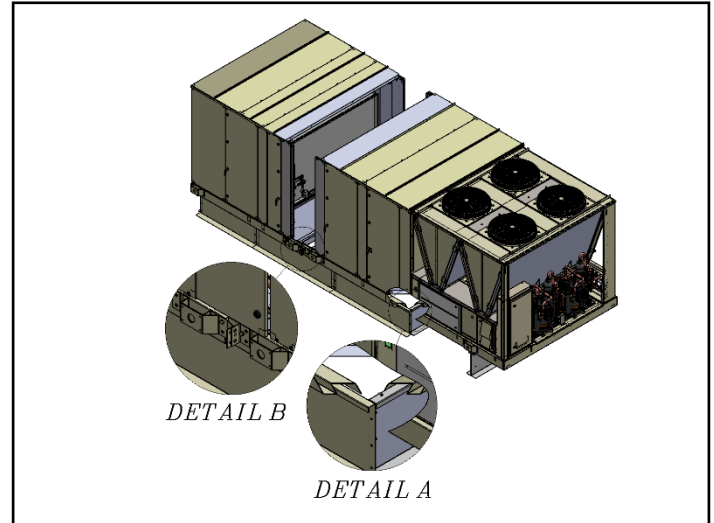
3. Set the return end section over roof curb pocket (Figure 62). Make sure locators underneath are aligned in the right place.

**Figure 62: Align Locators Underneath**



4. Carefully lower section into place, making sure the roof curb engages the recesses in the unit base (Figure 63).

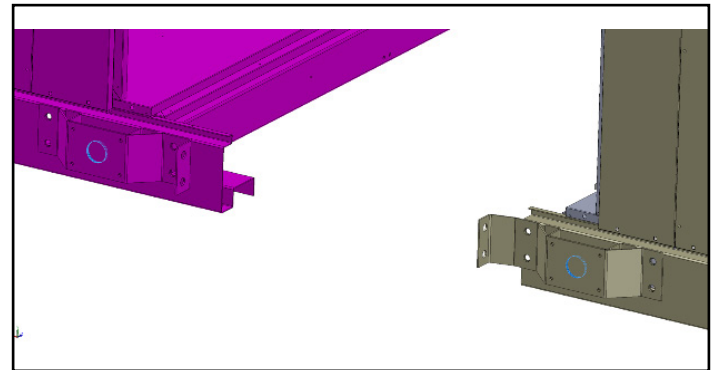
**Figure 63: Set Sections Over Roof Curb**



**NOTE:** The design of the lifting lugs is such to help align the 2 sections on the curb. It is critical that the unit base is co-planar down the air tunnel. The squareness of the unit air tunnel helps guarantee that the panels seal properly and keep out rain and prevent unit air leakage.

5. Bring the unit bases together by pulling lifting lugs together until the base rails touch. It is acceptable to use a come-along type cable puller attached to the lifting lug eyelets to assist in pulling the sections together. If using a come-along, both sides should be pulled simultaneously. The base rails should be in line and touching after this step (Figure 64).

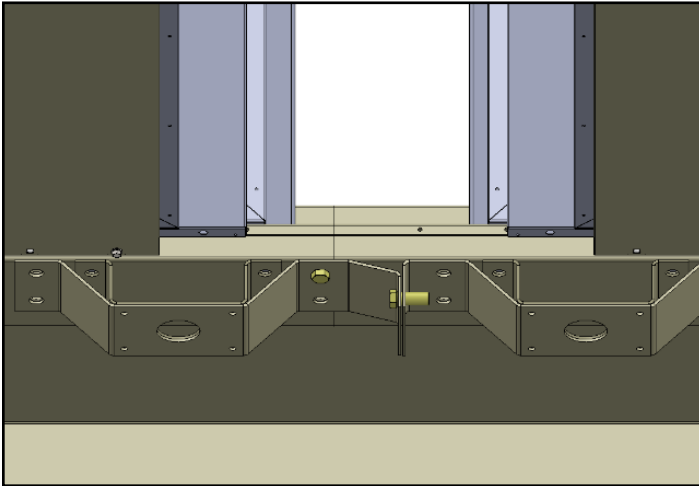
**Figure 64: Bring Together Two Halves**



6. Bolt together bases with the provided bolts, washers, and nuts. Check alignment of base rails for panel alignment (Figure 65).

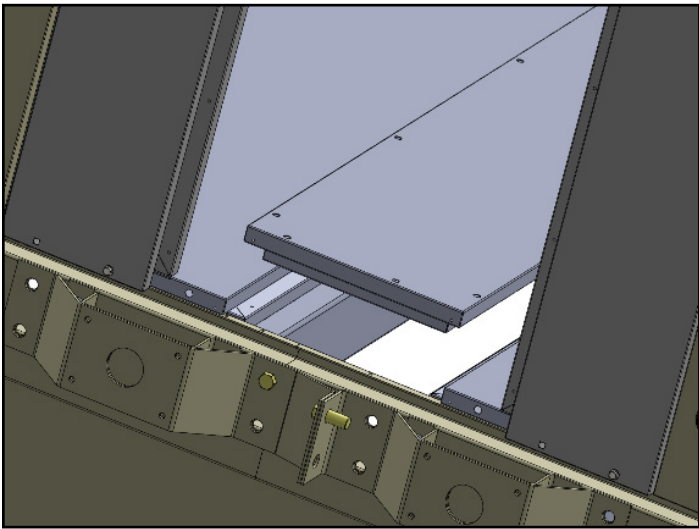
**NOTE:** The bolts are not to be used to pull the two sections together.

**Figure 65: Assembly Base Rails**



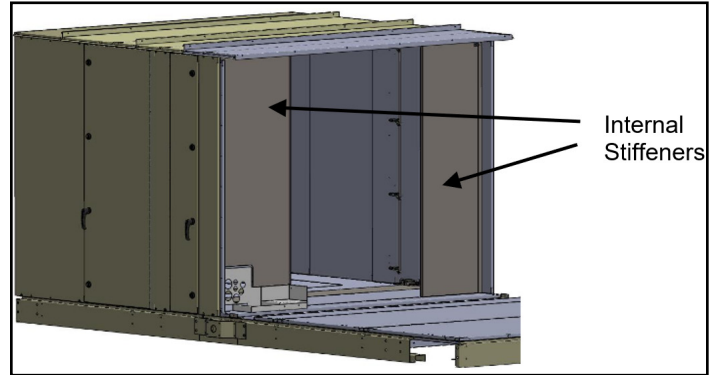
7. Place and fasten deck panel to base (Figure 65). All fasteners in the deck panel need to be fastened to a torque of 35 in-lbs and approximately flush with the deck sheet-metal.

**Figure 66: Install Deck Panel to Base**



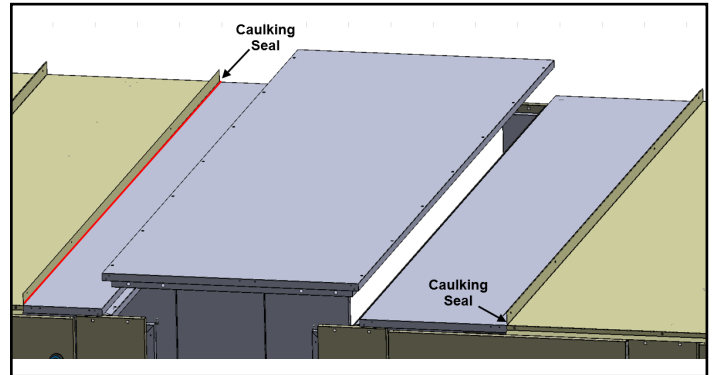
8. Remove internal stiffeners and recycle.

**Figure 67: Remove Stiffeners**



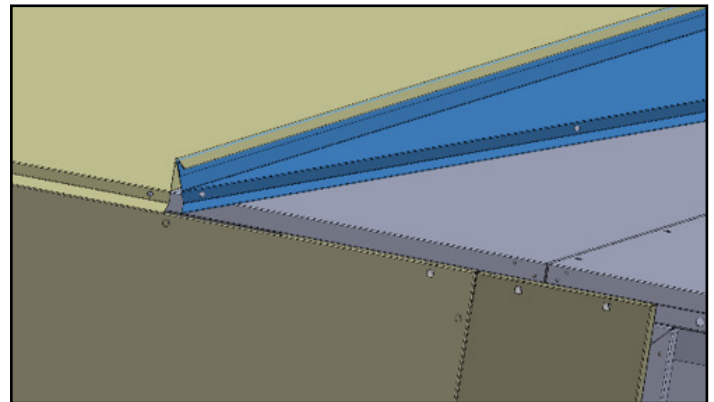
9. Place and fasten roof panel (there are 2 hex fasteners per side). Begin by manually turning the hex fasteners to ensure they do not cross thread. There will also be multiple flat head fasteners across the air tunnel along both seams. Fasten all fasteners to ensure a proper seal.

**Figure 68: Install Roof Panel**

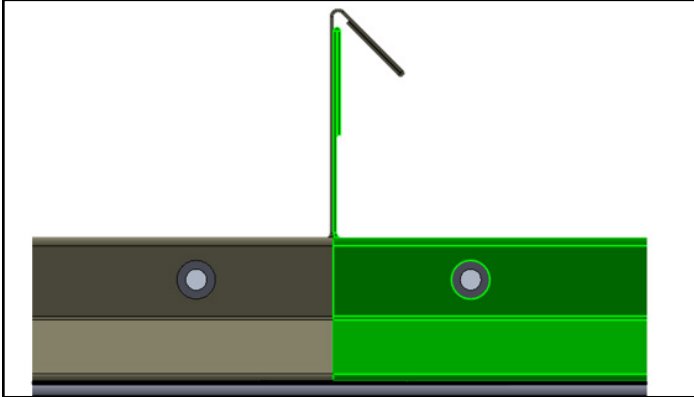


10. Add rain covers (Figure 69) by liberally applying caulk (Figure 68) to prevent leaks from rain or moisture. Tip hemmed lip in under previous rain cover (Figure 70).

**Figure 69: Install Rain Covers**

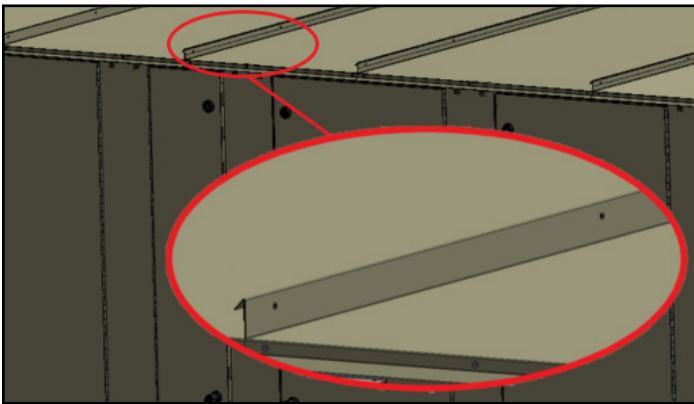


**Figure 70: Standing Seam**



11. Use the provided #10 sheet metal screws to secure the rain cover to the roof panels (up to 4 per side). Use the same screws to secure the standing seam (Figure 71).

**Figure 71: Fasten Standing Seam**



12. Install raceway junction box and connect the wiring.

**⚠ DANGER**

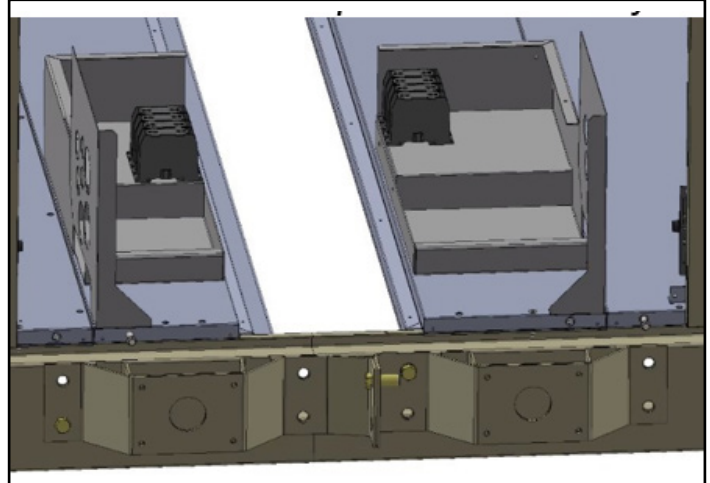
LOCKOUT/TAGOUT all power sources prior to wiring or servicing the unit. Hazardous voltage can cause serious injury or death. Disconnect electric power before servicing equipment. More than one disconnect may be required to de-energize the unit.

**⚠ CAUTION**

Connect the power block correctly and maintain proper phasing. Improper installation can cause severe equipment damage.

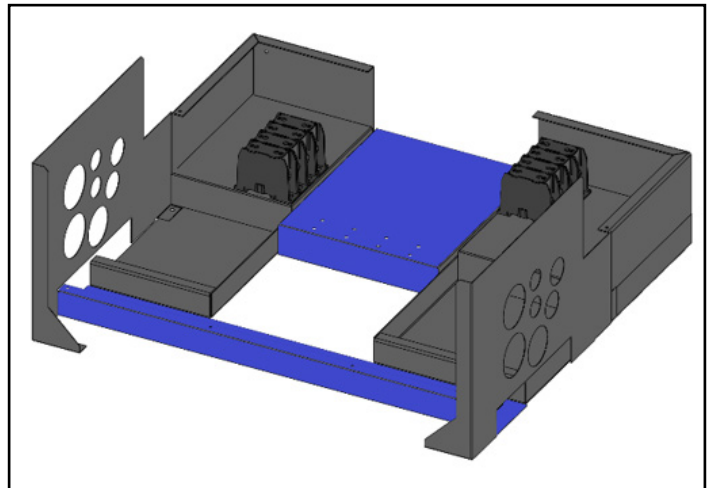
The wiring to the unit will be pulled back into either side of the shipping split modules. This wiring needs to be routed per the wiring diagram to ensure the proper operation of the unit (Figure 72).

**Figure 72: Terminal Box Prior to Assembly**



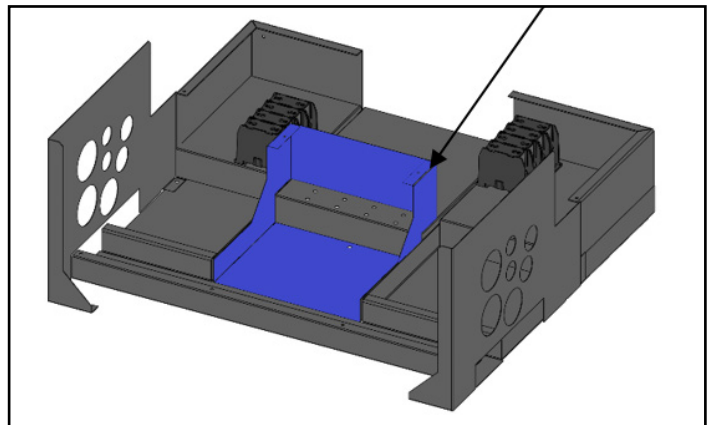
13. Install the low voltage raceway (Figure 73) by peeling back the plate and fastening in place by aligning the center hole with the hole in the deck, and the connection of the high voltage box by fastening the two screws in the back.

**Figure 73: Low Voltage Raceway**



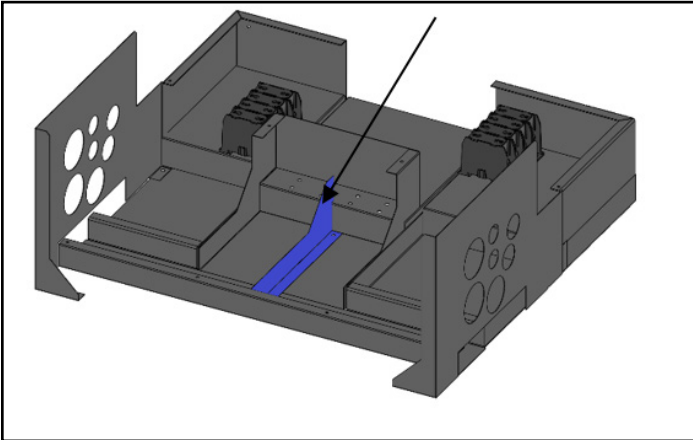
14. Install the high-to-low voltage divider (Figure 74).

**Figure 74: High-to-Low Voltage Divider**



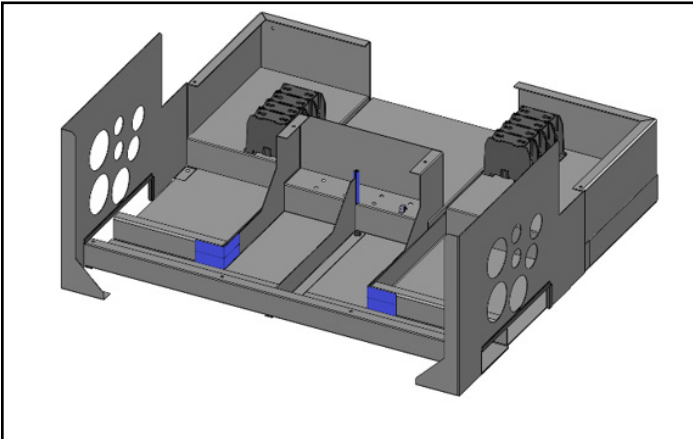
15. Install the low voltage divider (Figure 75).

**Figure 75: Low Voltage Divider**



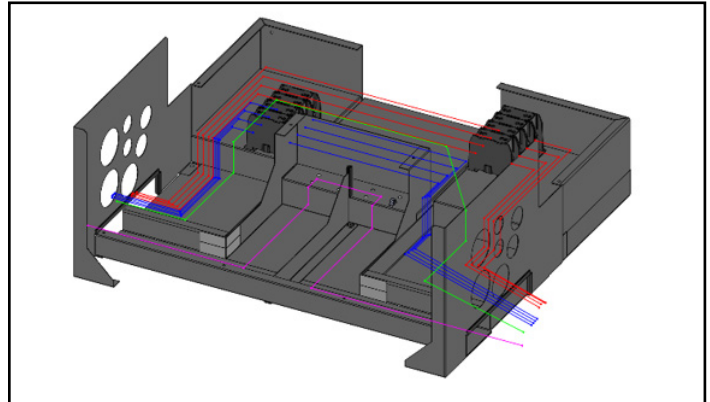
16. Install the edge protector on the low voltage divider and install the UHMW tape on the corners of the low voltage raceway (2 - 4 in. pieces stacked vertical on each corner).

**Figure 76: Edge Protectors**



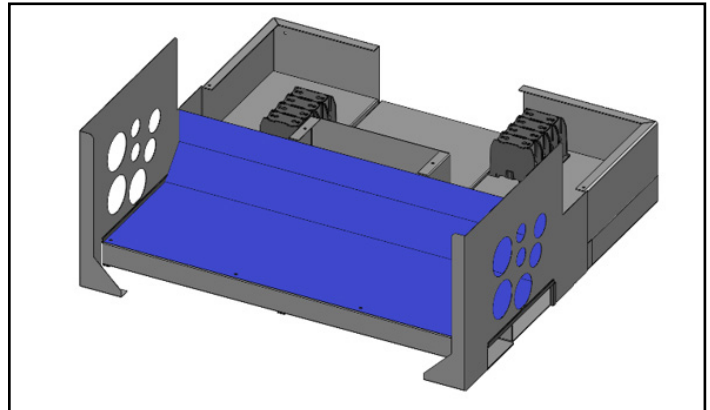
17. Connect the wires per the wiring schematic. In the low voltage raceway, connect the plugs that mate. The wires should be routed up to the platform and wire-tied such that the plugs sit on the platform. High voltage wires that are pulled back from the landing should be routed around the low voltage trough and passed into the high voltage raceway on the other side. Pull to the appropriate landing spot and connect the wires. High voltage wires that are split should be routed to the appropriate power block on the opposite side of the split. If there is pneumatic tubing for pressure switches or transducers that cross the shipping split, the tubing will need to be routed in the low voltage raceway. Connect matching labels with the provided barbed hose fitting.

**Figure 77: Route Wires**



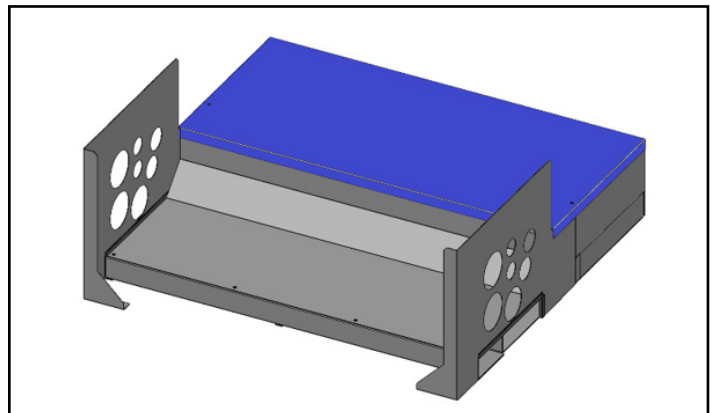
18. After all the wires have been properly connected, attach the low voltage cover (Figure 78) with the plastic clips through the holes on the front edge.

**Figure 78: Low Voltage Cover**



19. Attach the high voltage cover (Figure 79).

**Figure 79: High Voltage Cover**



20. Make refrigeration connections.

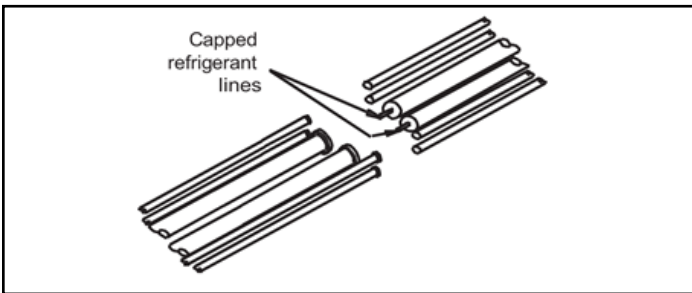
**NOTICE**

If the indoor coil is within 18 in. of the Shipping Split, remove Expansion Valve Bulbs before brazing the suction lines to prevent heat damage to the bulb. These will need to be reattached once all the brazing is completed to have a properly functioning machine. Install the sensing bulbs in the same location as received.

Refrigeration tubes are shipped with a nitrogen holding charge. This should be safely released through the depression of a Schrader valve until the charge has been reduced to atmospheric pressure.

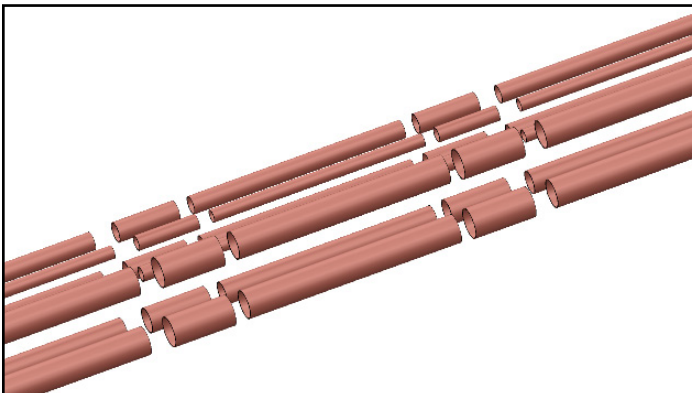
Removed the caps of the refrigeration tubing preferably by using a tube cutter. If a tube cutter is not possible, take caution to not have any remaining copper chips inside of the tube before brazing starts. Reconnect refrigerant piping. [Figure 80](#) illustrates what the installer sees at the shipping split.

**Figure 80: Braze Refrigerant Pipe Joints**



Given refrigerant piping is separated by shipping splits, the procedure must be followed through per the unit's refrigerant system requirements. [Figure 81](#) illustrates couplers and extensions to be added upon installation. Tube sizes and couplers must match manufactured tube sizes.

**Figure 81: Couplers and Extensions**

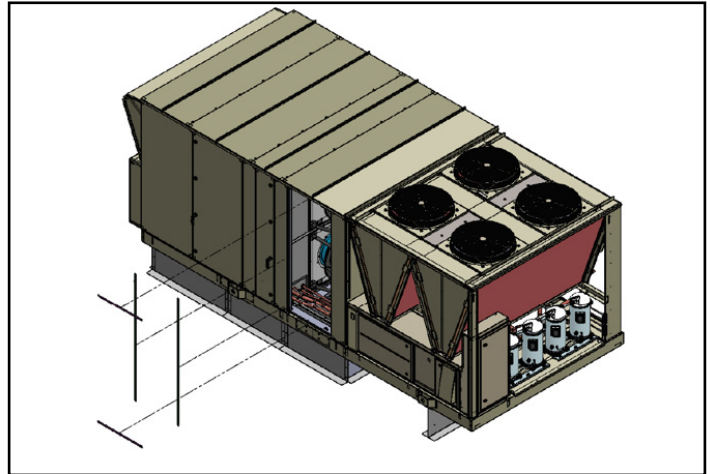


**CAUTION**

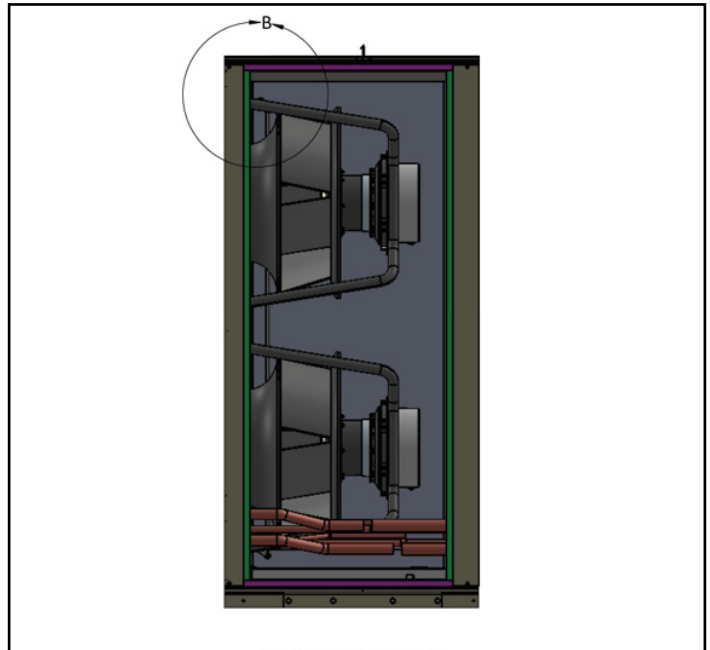
Protect wire harness from brazing heat, which can cause severe equipment damage.

21. Install the UHMW tape on the door frame ([Figure 82](#) and [Figure 83](#)). Attach the tape to the galvanized steel frame. The vertical should be installed first. The horizontal should be installed second, overlapping the vertical strips that were previously installed ([Figure 84](#)).

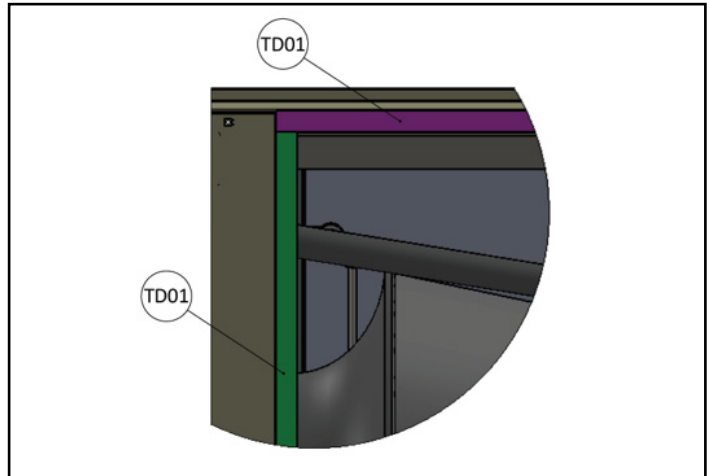
**Figure 82: UHMW Tape Application**



**Figure 83: Tape Location**

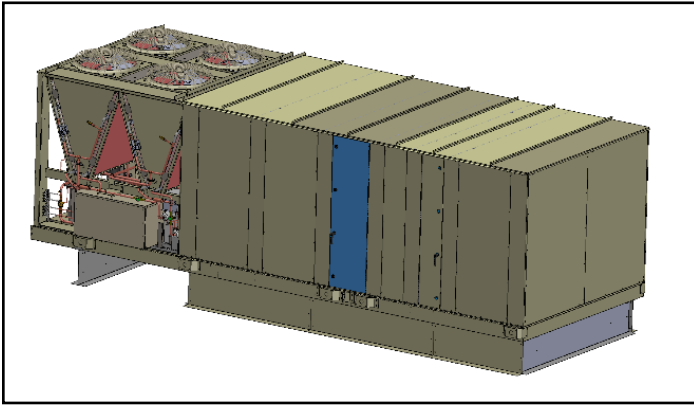


**Figure 84: Tape Overlap Detail**



- Attached door hinges to vertical structure of the cabinet on both sides of the unit with handles towards condenser end and engaging strike plates (see [Figure 85](#)).

**Figure 85: Install Doors**



- Leak check, evacuate, and charge the system per the unit's data plate information. It is important that standard refrigeration practices are followed for leak check, evacuation and charge for this unit. If you need assistance on these procedures, please contact Daikin Applied Technical Response Center via [www.DaikinApplied.com](http://www.DaikinApplied.com).

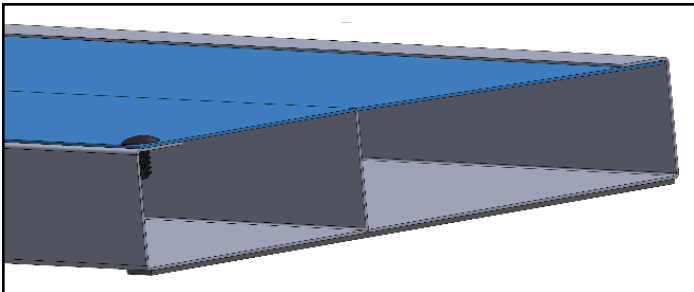
## Reconnecting Power and Control Wire

### CAUTION

Connect the power block correctly and maintain proper phasing. Improper installation can cause severe equipment damage.

- Once the sections are physically reconnected, and raceway extension is installed across shipping splits ([Figure 72 on page 43](#)), wires can be routed and connected.
- Run power wires through raceway channel for high voltages (greater than 110 volts) by pulling back to control box for termination or connect to terminal blocks one-to-one at splits, per the unit's electrical schematics.

**Figure 86: Separate Low Voltage Wire From High Voltage in Raceway**



- Run wire harness through raceway channel for low voltages (equal or less than 110 volts). Reconnect control wire harnesses to plugs at splits or pull back to control box for proper termination, per the unit's electrical schematics.

- Make all electrical connections per the unit's electrical schematics.
- Reinstall raceway cover as shown in [Figure 72](#) after routing of the control wires is complete.

## Unit Piping

### Condensate and Defrost Drain

#### WARNING

Drain pans must be cleaned periodically. Uncleaned drain pans can cause illness. Cleaning should be performed by qualified personnel with an alkaline based biodegradable cleaning solution.

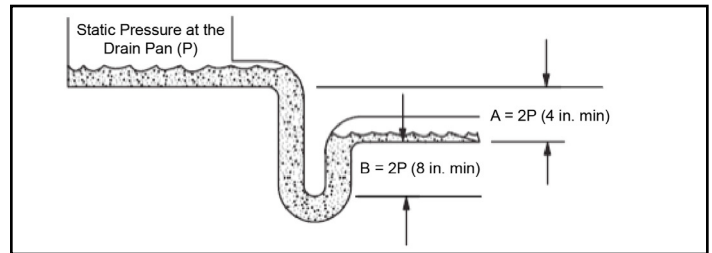
Units with an A-, B-, or C-Cabinet configuration are provided with a 1.0" male NPT condensate drain connection, while units with a D- or E-Cabinet configuration are provided with a 1.5" male NPT condensate drain connection. Units with an A-, B-, or C-Cabinet configuration also have two 1.0" male NPT defrost water drain connections for defrost water. Refer to certified drawings for the exact location.

#### Condensate Drain

For proper drainage, level the unit and drain pan side to side and install a P-trap.

Units may have positive or negative pressure sections. Use traps in both cases with extra care given to negative pressure sections. In [Figure 87](#), "P" is the static pressure at the drain pan in inches W.C. As a conservative measure to prevent the cabinet static pressure from blowing or drawing the water out of the trap and causing air leakage, dimension A should be two times the maximum static pressure encountered in the coil section in inches W.C. or a minimum of 4 inches, whichever dimension is greater. Dimension B should also have a dimension of twice the maximum static pressure at the drain pan or a minimum of 8 in, whichever dimension is greater.

**Figure 87: Condensate Drain Connection**



Draining condensate directly onto the roof may be acceptable; refer to local codes. Provide a small drip pad of stone, mortar, wood, or metal to protect the roof against possible damage.

If condensate is piped into the building drainage system, pitch the drain line away from the unit a minimum of 1/8" per foot. The drain line must penetrate the roof external to the unit.

Refer to local codes for additional requirements. Sealed drain lines require venting to provide proper condensate flow.

Where the cooling coils have intermediate condensate pans on the face of the evaporator coil, copper tubes near both ends of the coil provide drainage to the main drain pan. Check that the copper tubes are in place and open before the unit is put into operation. Check that this tube is open before putting the unit into operation and as a part of routine maintenance.

Drain pans in any air conditioning unit have some moisture in them, allowing micro-organisms to grow. Therefore, periodically clean the drain pan to prevent this buildup from plugging the drain and causing the drain pan to overflow.

**Defrost Condensate Drain (Heat Pump Units)**

For proper drainage, make sure unit is level.

Draining defrost water directly onto the roof may be acceptable; refer to local codes. Provide a small drip pad of stone, mortar, wood, or metal to protect the roof against possible damage.

If defrost drain water is piped into the building drainage system, pitch the drain line away from the unit a minimum of 1/8" per foot. The drain line must penetrate the roof external to the unit.

Refer to local codes for additional requirements. Sealed drain lines require venting to provide proper defrost water flow.

Check that the pipes leading from defrost water drain pans are in place, clear, and open before the unit is put into operation. Also, check these pipes as a part of routine maintenance.

Drain pans in any air conditioning unit have some moisture in them, allowing micro-organisms to grow. Therefore, periodically clean the drain pan to prevent this buildup from plugging the drain and causing the drain pan to overflow.

Depending on the length of the exposed drain pan piping, it may be necessary to add field heat tracing to the extended piping to prevent the defrost condensate from freezing during low ambient temperature operation. Refer to the unit wiring schematics for details on wiring the heat trace to the provided contacts inside the unit control panel. The contacts in the control panel will energize the heat trace when the drain pan heaters are active. If continuous heat is required, an alternate power source may be needed. See "Defrost Mode (Heat Pumps Only)" on page 77 for operation details.

**Hot Water or Hot Water Integral Face and Bypass (IFB)**

**⚠ CAUTION**

Coil freeze possible when the ambient temperature is below 35°F and can result in poor equipment operation or damage to the equipment. Follow instructions for mixing antifreeze solution used. Some products have higher freezing points in their natural state than when mixed with water. The freezing of coils is not the responsibility of Daikin Applied.

Hot water coils are not normally recommended for use with entering air temperatures below 35°F (1.6°C). No control system can guarantee a 100% safeguard against coil freeze-up. Glycol solutions or brines are the only freeze-safe media for operation of water coils at low entering air temperature conditions.

**NOTE:** All coils have vents and drains factory installed.

Hot water coils are provided without valves as a standard unit, requiring field installation of valves and piping. As an option, the hot water coil is supplied with either a two-way or three-way valve and actuator motor from the factory. Refer to the submittal drawings to determine unit configuration. The submittal drawing will also have information about the line size connections.

**NOTE:** Factory-installed water valves and piping are bronze, brass, and copper. Dissimilar metals within the plumbing system can cause galvanic corrosion. To avoid corrosion, provide proper dielectric fittings as well as appropriate water treatment when making a connection to a pipe that is not copper, bronze or brass.

A factory provided floor knockout location is provided on every unit equipped with a hot water coil. Refer to the certified drawings for the recommended piping entrance locations. Seal all piping penetrations to prevent air and water leakage.

**Table 6: Hot Water Connection Size**

		Hot Water Connections	
A, B, C, and D Cabinet	Hot Water	1 Row	1-1/2 in.
		2 Row	2-1/2 in.
	IFB	2 Row	
		3 Row	
E Cabinet	IFB	2 Row	3 in.
		3 Row	

The contents of Table 6 show the connection piping sizes based on the coil selection. Valve package connections are F-NPT and therefore will require a tapered pipe field connection (M-NPT). Header connection points are cup fittings and therefore will require a straight pipe connection (M-SWT).

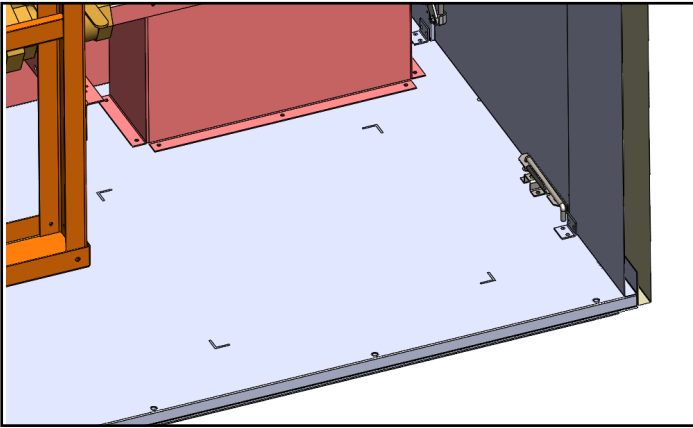
## Hot Water Piping

On the floor panel behind the drain pan are a series of corner punches in the panel, as shown in [Figure 88](#). When connected, this will form a safe area to run piping through.

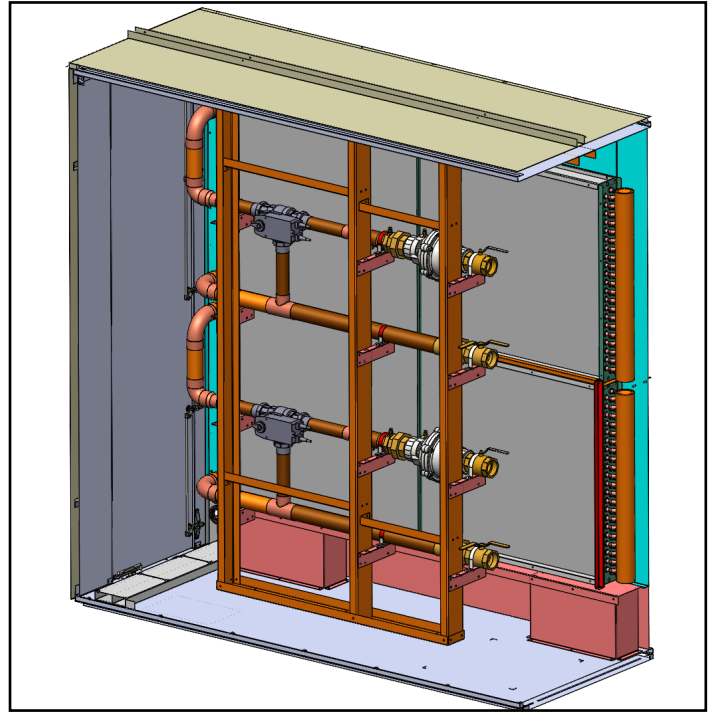
**NOTE:** Field-installed piping must be supported by the building structure. Field-installed piping should not be allowed to hang from the valves or be supported by the cabinet floor.

An alternative method is to continue the valve package piping and run the piping straight through the wall panel. Be sure to properly insulate exposed piping based on your geographical location.

**Figure 88: Hot Water C and D-Cabinet Floor Markings (Piping)**



**Figure 89: C and D-Cabinet Hot Water Heat Section (Shown with Factory 3-way Valve and Piping with Stacked Coils, No Bypass)**



**Figure 90: B-Cabinet IFB Hot Water**

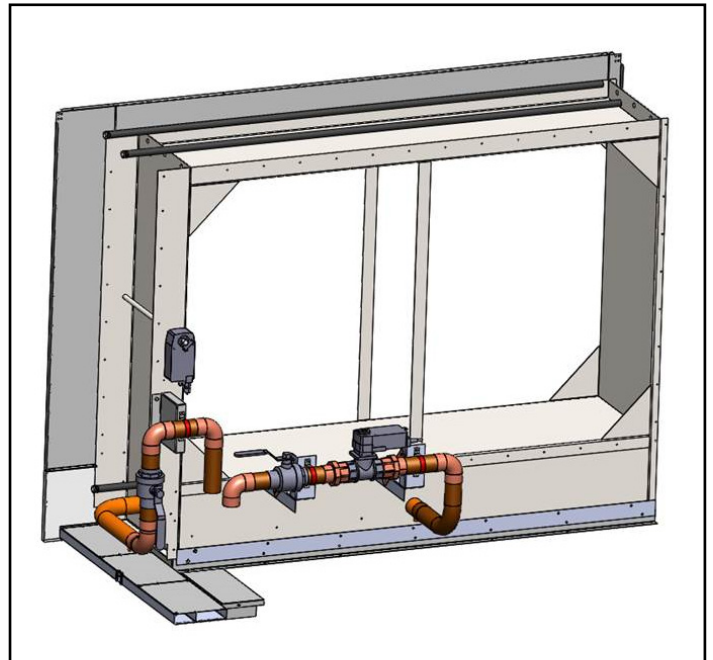
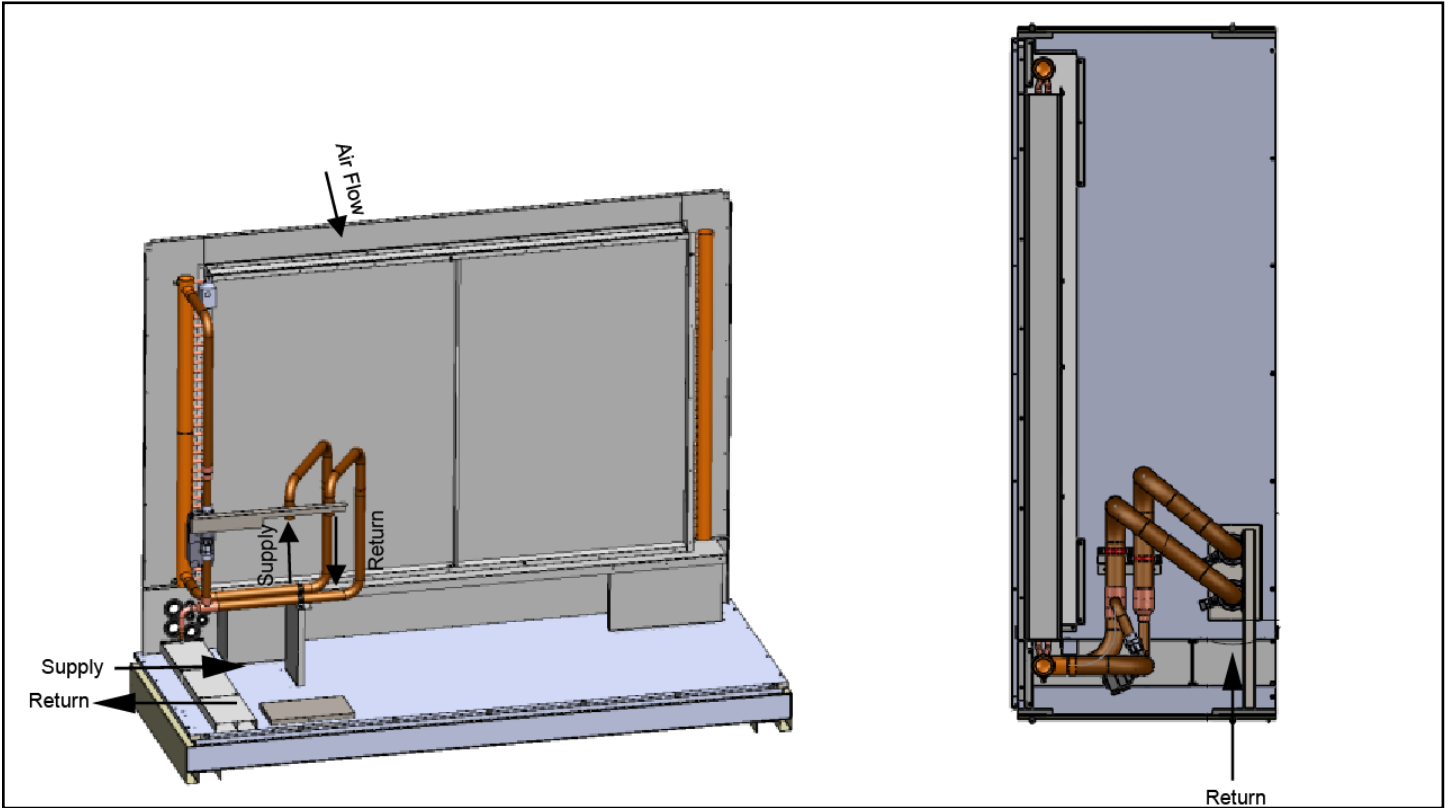
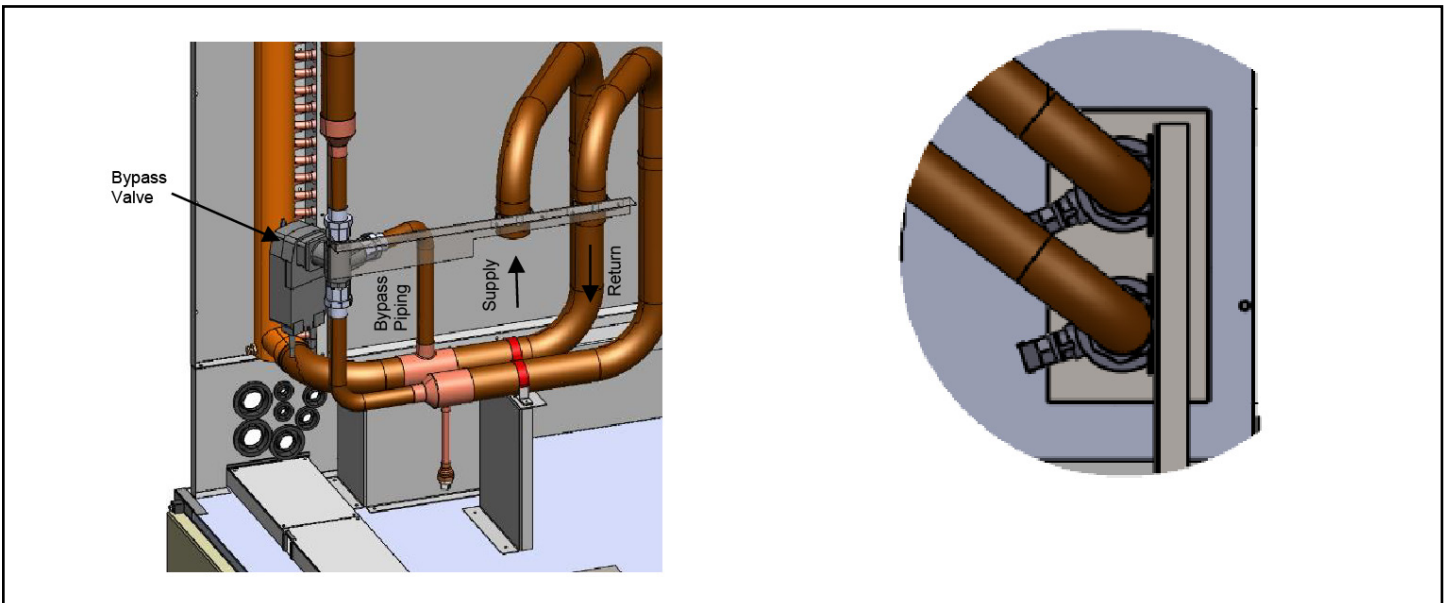


Figure 91: A and B-Cabinet Hot Water Heat Section (Shown with Factory Valve and Piping, no Bypass)



**NOTE:** Horizontal Supply and Return will be through the fixed panel in line with the pipe connections.

Figure 92: B-Cabinet Hot Water Bypass Valve Package



## Steam Coil or Steam Integral Face and Bypass (IFB) Coil

Steam coils are provided without valves as a standard unit, requiring field installation of valves and piping. As an option, the steam coil is supplied with a two-way valve and actuator motor from the factory. Refer to the submittal drawings to determine unit configuration. The submittal drawing will also have information about the line size connections.

The steam heat coil is pitched at 1/8" (3 mm) per foot (305 mm) to provide positive condensate removal.

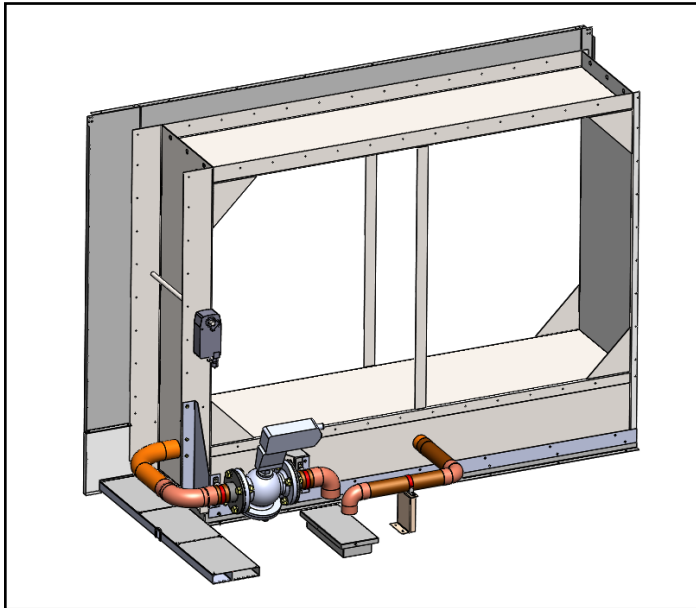
Refer to the certified drawings for the recommended piping entrance locations. All piping penetrations must be sealed to prevent air and water leakage.

**NOTE:** The valve actuator spring returns to a stem up position upon power failure. This allows full flow through the coil.

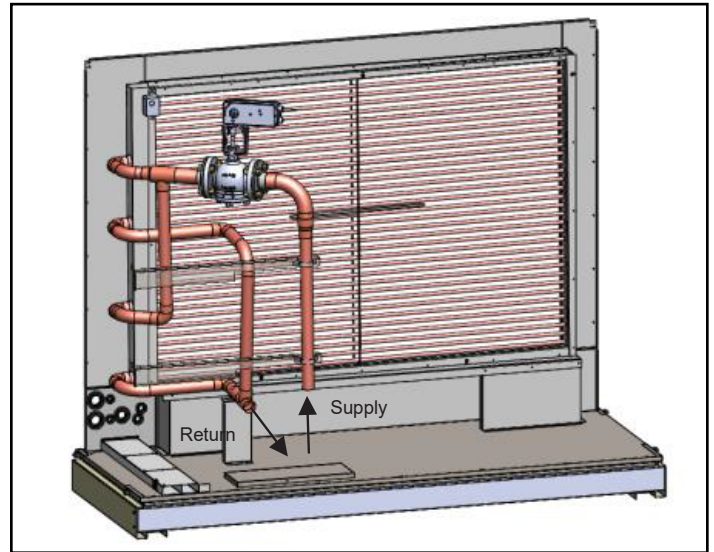
**Table 7: Steam and IFB Connection Size**

Type	Cabinet	Rows	Inlet	Outlet
Steam	B Cabinet	All Rows	2 in.	2 in.
IFB	B & C Cabinet	1 Row	2-1/2 in.	2 in.
		2 Row	3 in.	2-1/2 in.
	D Cabinet	1 Row	3 in.	2-1/2 in.
		2 Row	4 in.	3 in.
Steam	E Cabinet	1 Row	3 in.	2.5 in.
		2 Row	4 in.	3 in.

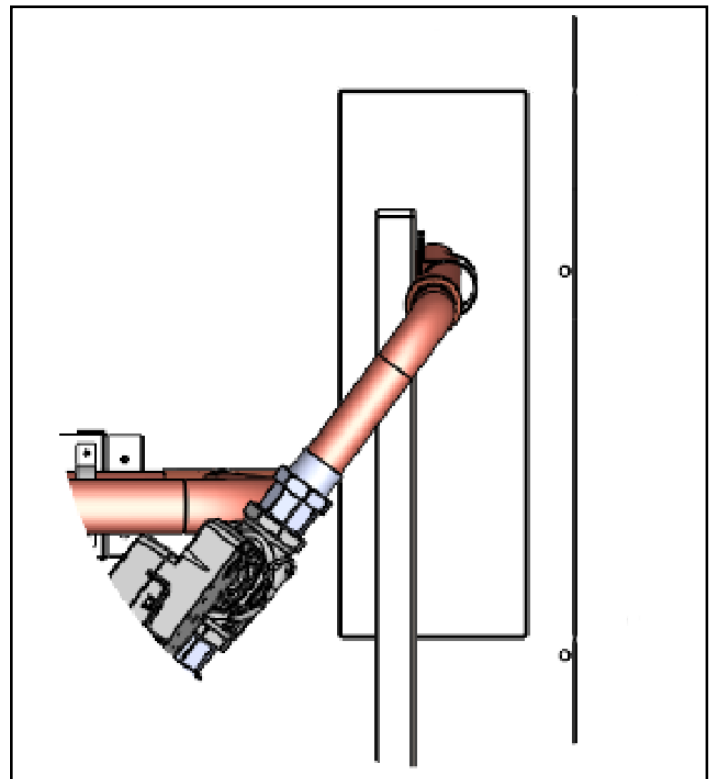
**Figure 93: IFB Steam Heat Section**



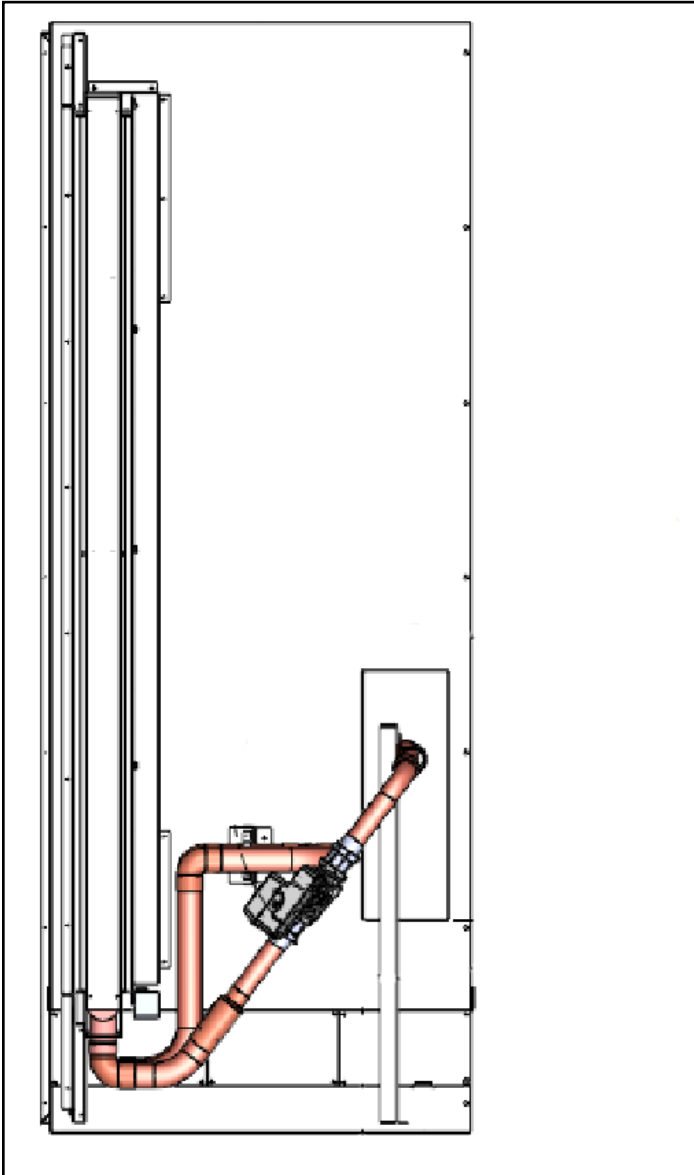
**Figure 94: B-Cabinet Steam Heat Section (Valve and Factory Piping)**



**Figure 95: B-Cabinet Steam Heat Section (Valve and Factory Piping)**



**Figure 96: B-Cabinet Steam Heat Section (Valve and Factory Piping)**



### **Steam Piping Recommendations**

1. Be certain that adequate piping flexibility is provided. Stresses resulting from expansion of closely coupled piping and coil arrangement can cause serious damage.
2. Do not reduce pipe size at the coil return connection. Carry return connection size through the dirt pocket, making the reduction at the branch leading to the trap.
3. Install vacuum breakers on all applications to prevent retaining condensate in the coil. Generally, the vacuum breaker is to be connected between the coil inlet and the return main. However, if the system has a flooded return main, the vacuum breaker to the atmosphere; the trap design should allow venting of the large quantities of air.
4. Do not drain steam mains or takeoffs through coils. Drain mains ahead of coils through a steam trap to the return line.
5. Do not attempt to lift condensate.
6. Pitch all supply and return steam piping down a minimum of 1" (25 mm) per 10 feet (3 m) of direction of flow.

### **Steam Trap Recommendations**

1. Size traps in accordance with manufacturers' recommendations. Be certain that the required pressure differential will always be available. Do not undersize.
2. Float and thermostatic or bucket traps are recommended for low pressure steam. Use bucket traps on systems with ON/OFF control only.
3. Locate traps at least 12" (305 mm) below the coil return connection.
4. Always install strainers as close as possible to the inlet side of the trap.
5. A single tap may generally be used for coils piped in parallel, but an individual trap for each coil is preferred.

### **Steam Coil Freeze Conditions**

If the air entering the steam coil is below 35°F (2°C), note the following recommendations:

1. Supply 5 psi (34.5 kPa) steam to coils at all times.
2. Modulating valves are not recommended. Control should be by means of face and bypass dampers.
3. As additional protection against freeze-up, install the tap sufficiently far below the coil to provide an adequate hydrostatic head to ensure removal of condensate during an interruption on the steam pressure. Estimate 3 ft. (914 mm) for each 1 psi (7 kPa) of trap differential required.
4. If the unit is to be operated in environments with possible freezing temperatures, an optional freezestat is recommended.

## Chilled Water

**CAUTION**

Coil freeze possible when the ambient temperature is below 35°F (1.6°C) and can result in poor equipment operation or damage to the equipment. Follow instructions for mixing antifreeze solution used. Some products have higher freezing points in their natural state than when mixed with water. The freezing of coils is not the responsibility of Daikin Applied.

Cold water coils are not normally recommended for use with entering air temperatures below 35°F (1.6°C). No control system can guarantee a 100% safeguard against coil freeze-up. Glycol solutions or brines are the only freeze-safe media for operation of water coils at low entering air temperature conditions.

**NOTE:** All coils have vents and drains factory installed.

Cold water coils are provided without valves as a standard unit, requiring field installation of valves and piping. As an option, the cold water coil is supplied with either a two-way or three-way valve and actuator motor from the factory. Refer to the submittal drawings to determine unit configuration. The submittal drawing will also have information about the line size connections.

**NOTE:** All field installed piping should be insulated to prevent condensation from dripping into the cabinet.

**NOTE:** Factory-installed water valves and piping are bronze, brass, and copper. Dissimilar metals within the plumbing system can cause galvanic corrosion. To avoid corrosion, provide proper dielectric fittings as well as appropriate water treatment when making a connection to a pipe that is not copper, bronze or brass.

A factory provided floor knockout location is provided on every unit equipped with a cold water coil. Refer to the certified drawings for the recommended piping entrance locations. Seal all piping penetrations to prevent air and water leakage.

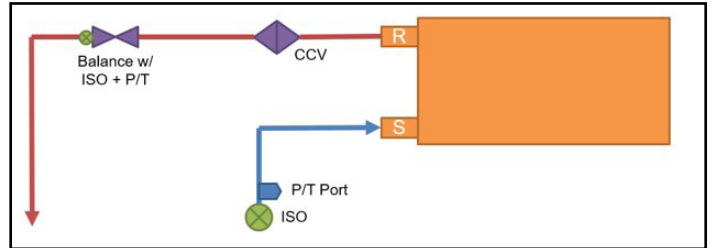
Table 8 shows the connection piping sizes based on the coil selection. Valve package connections will require a straight pipe connection and connections to the header pipe will require a coupling.

**Table 8: Cold Water Connection Sizes**

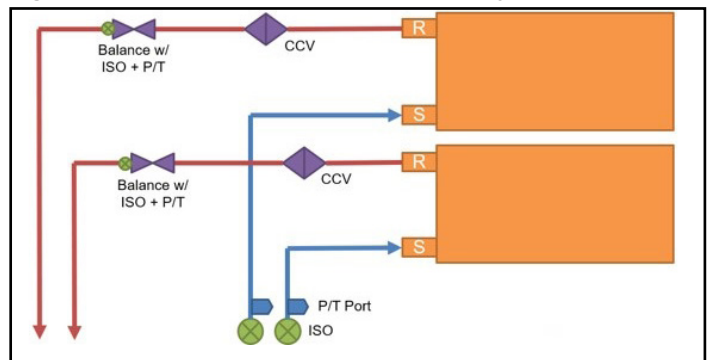
		Code 004 (Pos 5-7)					
		B24	B29	B34	C34	C39	C44
Code 009 (Pos 12)	T	2-½ in.	2-½ in.	2 in.	2 in.	2 in.	2 in.
	U	2-½ in.	3 in.	2-½ in.	2-½ in.	2-½ in.	2-½ in.
	V	2 in.	2-½ in.	2 in.	2 in.	2 in.	2 in.
	W	2-½ in.	3 in.	2-½ in.	2-½ in.	2-½ in.	2-½ in.
	Y	3 in.	3 in.	2-½ in.	2-½ in.	3 in.	3 in.
	1	2-½ in.	2-½ in.	2 in.	2 in.	2-½ in.	2-½ in.
	2	3 in.	3 in.	2-½ in.	2-½ in.	3 in.	3 in.
	3	3 in.	3 in.	3 in.	3 in.	3 in.	3 in.
	4	2-½ in.	2-½ in.	2 in.	2 in.	2-½ in.	2-½ in.
	5	3 in.	3 in.	2-½ in.	2-½ in.	3 in.	3 in.
	6	3 in.	3 in.	3 in.	3 in.	3 in.	3 in.
	7	2-½ in.	2-½ in.	2 in.	2 in.	2-½ in.	2-½ in.
8	3 in.	3 in.	2-½ in.	2-½ in.	3 in.	3 in.	
9	3 in.	3 in.	3 in.	3 in.	3 in.	3 in.	

The contents of Table 8 show the connection piping sizes based on the coil selection. Valve package connections are F-NPT and will require a tapered pipe field connection (M-NPT). Header connection points are straight pipe and will require a coupling (F-SWT).

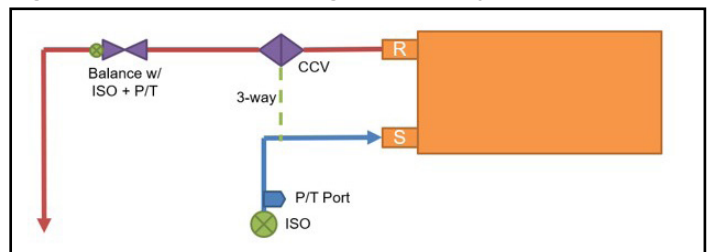
**Figure 97: Chilled Water Single Coil 2-Way Valve**



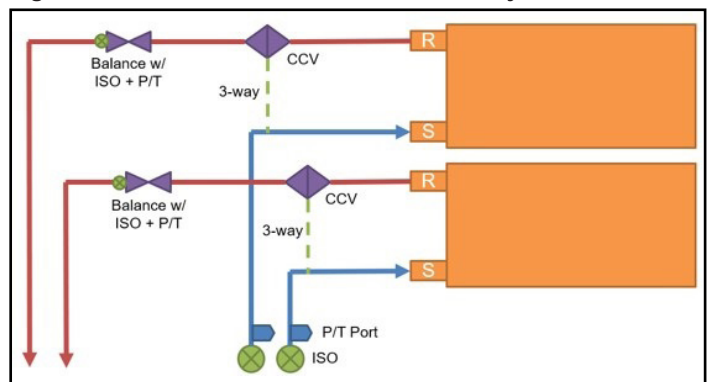
**Figure 98: Chilled Water Stacked Coil 2-Way Valve**



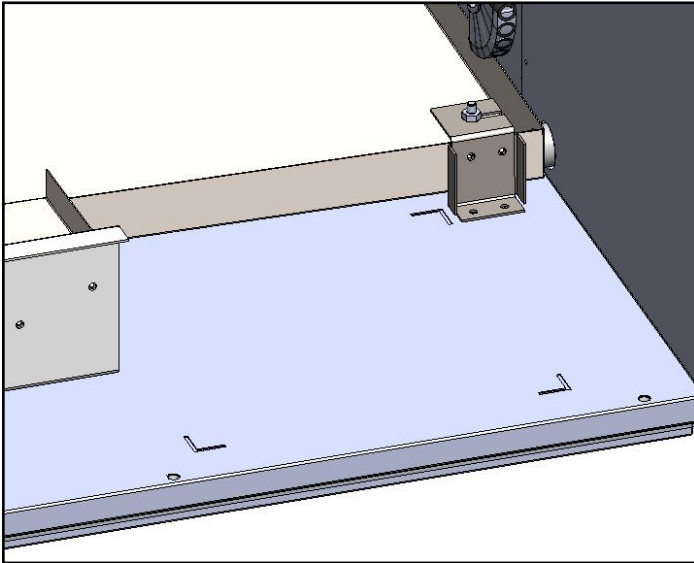
**Figure 99: Chilled Water Single Coil 3-Way Valve**



**Figure 100: Chilled water Stacked Coil 3-Way Valve**



**Figure 101: Floor Markings for Chilled Water (Piping)**



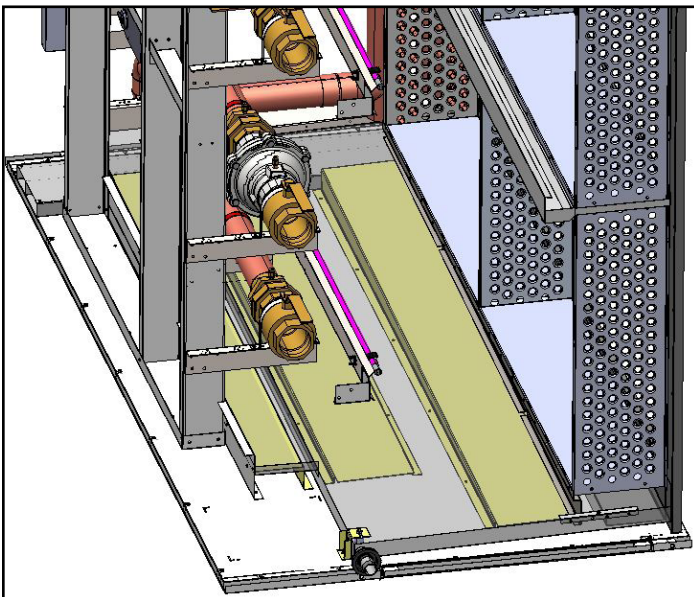
## Chilled Water Piping

On the floor panel behind the drain pan are a series of corner punches in the panel, as shown in Figure 101. When connected, this will form a 12 in. square signifying a safe area to run piping through.

**NOTE:** Field-installed piping must be supported by the building structure. Field-installed piping should not be allowed to hang from the valves or be supported by the cabinet floor.

An alternative method is to continue the valve package piping and run the piping straight through the wall panel. Be sure to properly insulate exposed piping based on your geographical location.

**Figure 102: Supports Under Drain Pan, Secondary Drain Pan (yellow), and Location of Drain Pan Connection Pipe**

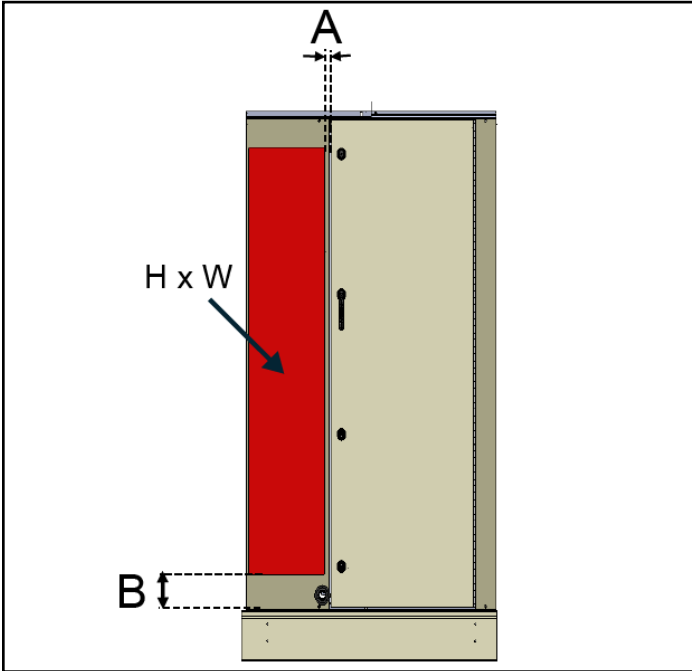


## Panel Piping Penetrations

When penetrations for unit piping are not made through the floor panel of the unit, penetrations can be made in specific areas along the side panels.

**NOTE:** “Left” or “Right” panel wall orientation is determined by facing the direction of airflow through the unit.

**Figure 103: Hot Water Side Cutout Dimensions**

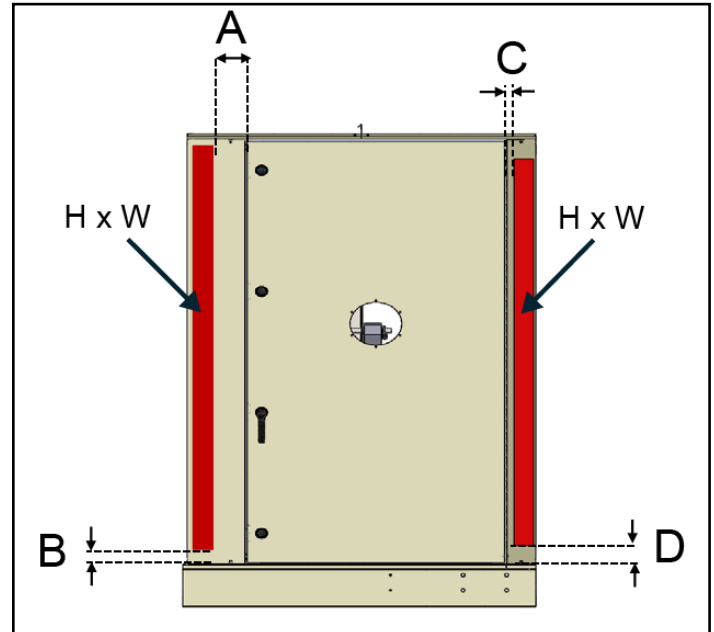


**Table 9: Hot Water Side Cutout Dimensions**

Cabinet Size	Dimensions (inches)			
	A	B	Width	Height
B	1	3	6.5	62
C				84.5
D			2.5	84.5
E				

**NOTE:** Variable dimensions are measured from either the bottom edge of the panel (vertically) or the inner edge of the panel (horizontally).

**Figure 104: Integral Face and Bypass (IFB) Side Cutout Dimensions**

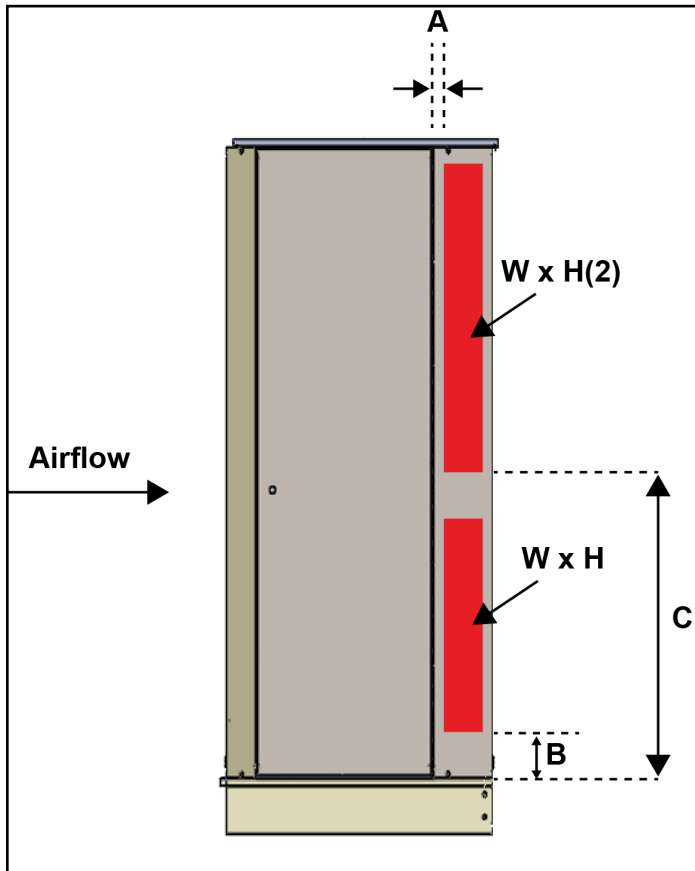


**Table 10: Integral Face and Bypass (IFB) Side Cutout Dimensions**

Cabinet Size	Dimensions (inches)					
	A	B	C	D	Width	Height
B	5	3	1	3	2.7	64
C						87
D						
E						

**NOTE:** Variable dimensions are measured from either the bottom edge of the panel (vertically) or the inner edge of the panel (horizontally).

**Figure 105: Steam WITH Valve Package Side Cutout Dimensions (Right Panel Only)**

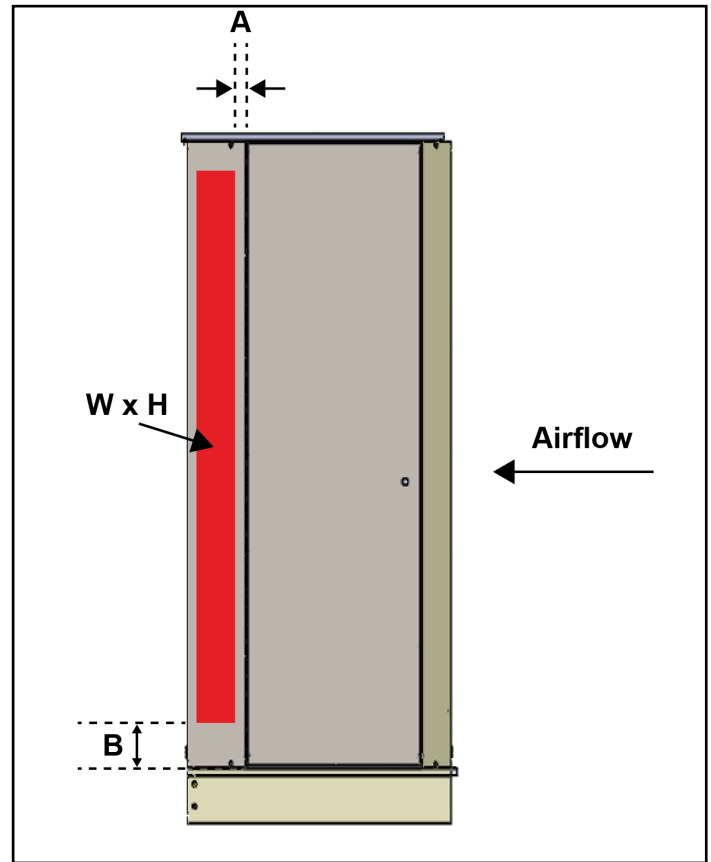


**Table 11: Steam WITH Valve Package Side Cutout Dimensions (Right Panel Only)**

Cabinet Size	Dimensions (inches)					
	A	B	C	Width	Height	Height(2)
B	1	3	22.5	6.5	14	43.5

**NOTE:** Variable dimensions are measured from either the bottom edge of the panel (vertically) or the inner edge of the panel (horizontally).

**Figure 106: Steam WITH Valve Package Side Cutout Dimensions (Left Panel Only)**

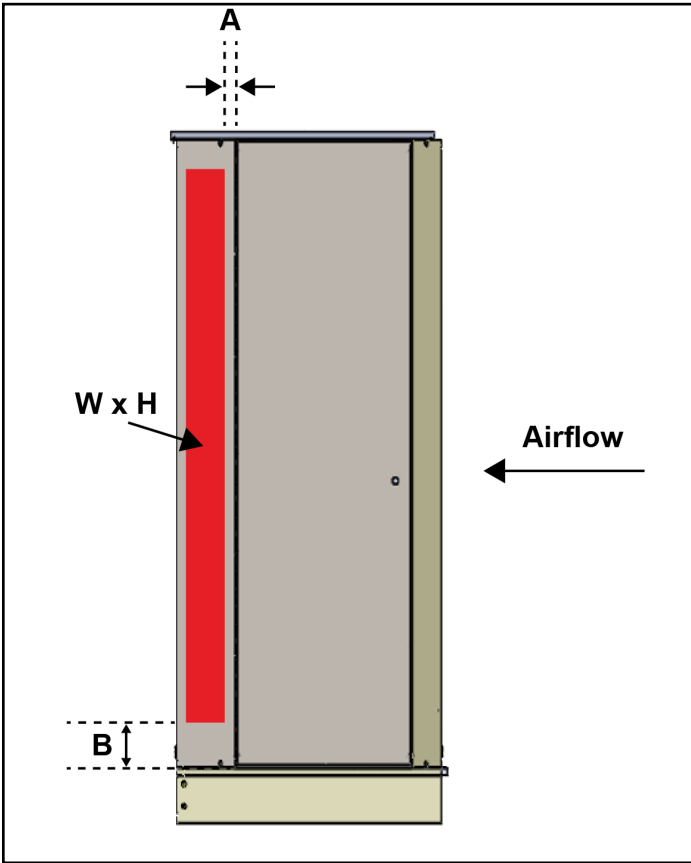


**Table 12: Steam WITH Valve Package Side Cutout Dimensions (Left Panel Only)**

Cabinet Size	Dimensions (inches)			
	A	B	Width	Height
B	1	3	6.5	63

**NOTE:** Variable dimensions are measured from either the bottom edge of the panel (vertically) or the inner edge of the panel (horizontally).

**Figure 107: Steam WITHOUT Valve Package Side Cutout Dimensions (Left or Right Panel)**

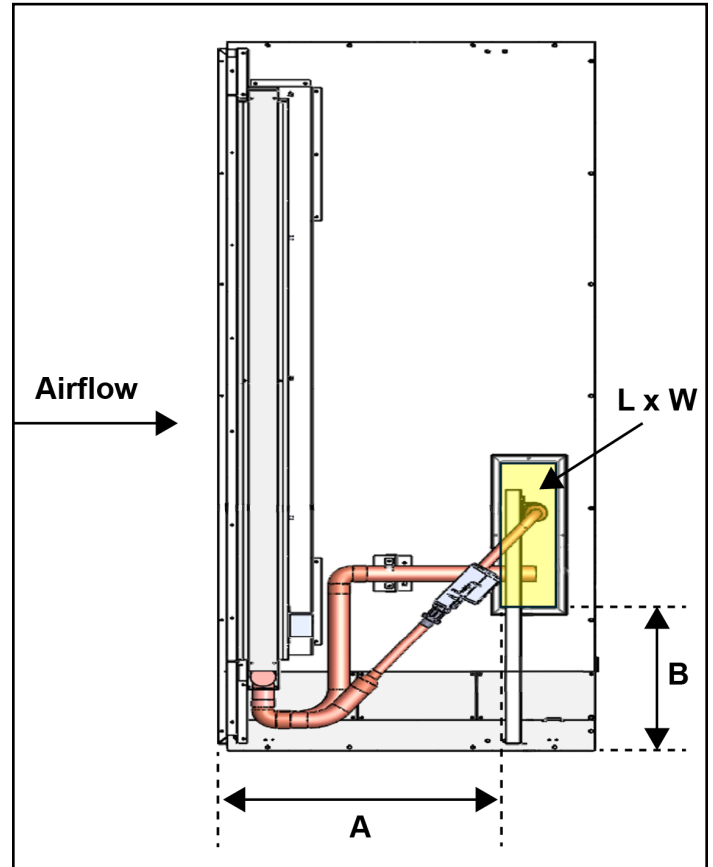


**Table 13: Steam WITHOUT Valve Package Side Cutout Dimensions**

Cabinet Size	Dimensions (inches)			
	A	B	Width	Height
B	1	3	6.5	63

**NOTE:** Variable dimensions are measured from either the bottom edge of the panel (vertically) or the inner edge of the panel (horizontally).

**Figure 108: Steam WITHOUT Valve Package Bottom Cutout Dimensions (Overhead View)**

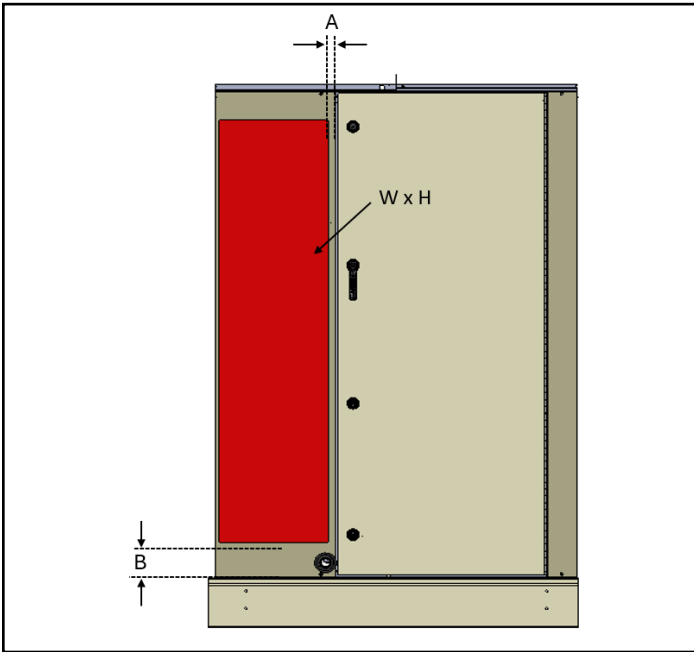


**Table 14: Steam WITHOUT Valve Package Bottom Cutout Dimensions**

Cabinet Size	Dimensions (inches)			
	A	B	Length	Width
B	27.55	19.78	19.6	5.56

**NOTE:** Variable dimensions are measured from either the bottom edge of the panel (vertically) or the inner edge of the panel (horizontally).

**Figure 109: Cold Water Side Cutout Dimensions (No UV Lights)**

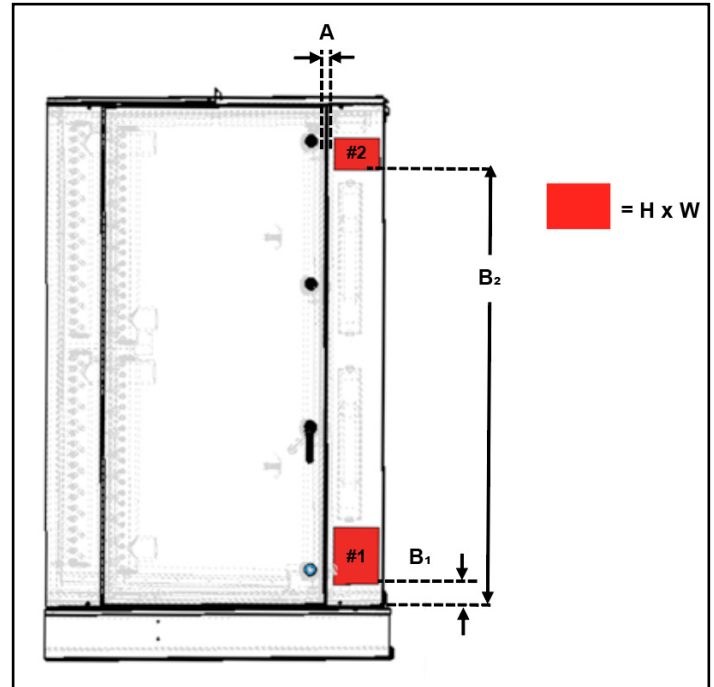


**Table 15: Cold Water Side Cutout Dimensions (No UV Lights)**

Cabinet Size	Dimensions (inches)				
	Wall	A	B	Width	Height
B	Right	1	3	6.5	62
	Left		5	14.5	60
C and D	Right		3	6.5	84.5
	Left		5	14.5	82.5

**NOTE:** Variable dimensions are measured from either the bottom edge of the panel (vertically) or the inner edge of the panel (horizontally).

**Figure 110: Cold Water Side Cutout Dimensions (Right Panel with UV Lights)**



**Table 16: Cold Water Side Cutout Dimensions (Right Panel with UV Lights)**

Cabinet Size	Coil Size	Dimensions (inches)							
		Cutout #1				Cutout #2			
		A	B <sub>1</sub>	Width	Height	A	B <sub>2</sub>	Width	Height
B	B24	1	3	6.5	8	1	33.5	6.5	31.5
	B29						5.5		
	B34						62		28
C and D	All								

**NOTE:** Variable dimensions are measured from either the bottom edge of the panel (vertically) or the inner edge of the panel (horizontally).

Figure 111: Cold Water Side Cutout Dimensions (Left Panel, with UV Lights)

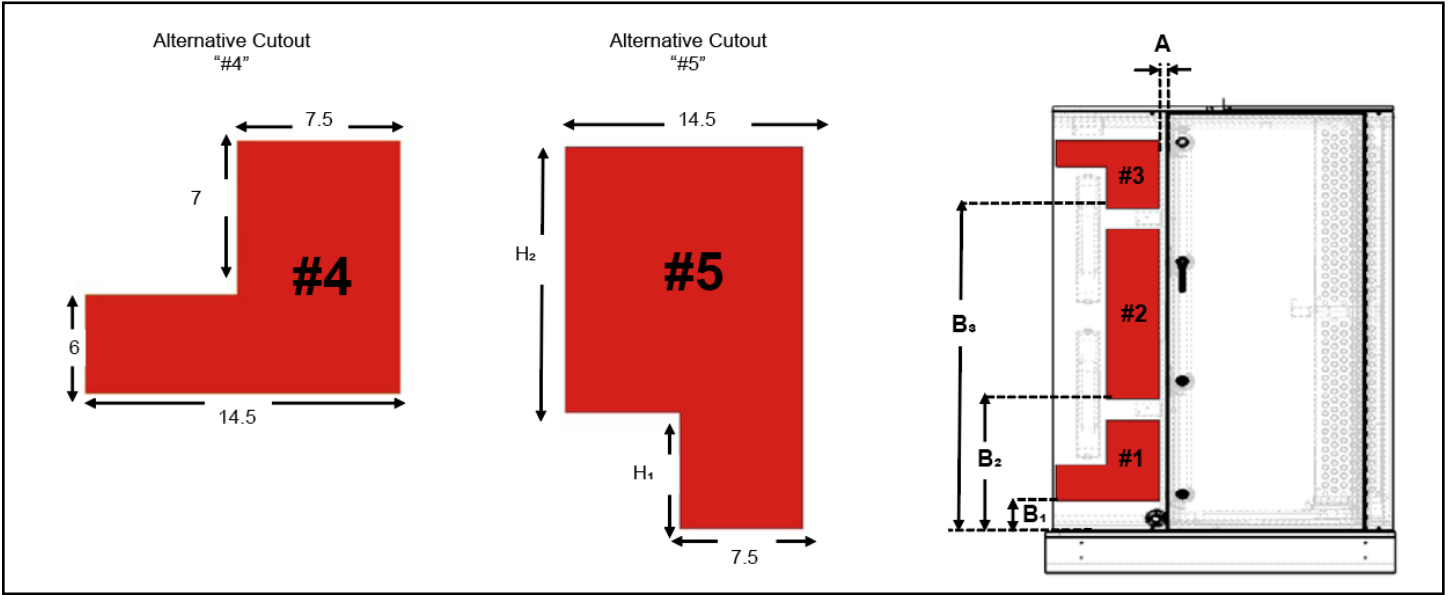


Table 17: Cold Water Side Cutout Dimensions (Left Panel, with UV Lights)

Cabinet Size	Coil Size	Dimensions (inches)													
		Cutout #1				Cutout #2				Cutout #3					
		A	B <sub>1</sub>	Width	Height	A	B <sub>2</sub>	Width	Height	A	B <sub>3</sub>	Width	Height <sub>1</sub>	Height <sub>2</sub>	
B	B24	1	5	See Alternative Cutout #4 in Figure 111	N/A				1	7.5	1	21	See Alternative Cutout #5 in Figure 111	12.5	31.5
	B29				N/A									6.5	5.5
	B34				21		29	53						6.5	28
C	C34				13		38	45						14.5	28
	C39						29	62						N/A	25.5
	C44						35	53						6.5	28
D	D44			38	59	0.5	28								
	D53			35	62	N/A	25.5								
	D59			38	62	N/A	25.5								

**NOTE:** Variable dimensions are measured from either the bottom edge of the panel (vertically) or the inner edge of the panel (horizontally).

## Damper Assemblies

The optional damper assemblies described in this section normally are ordered with factory-installed actuators and linkages. The following sections describe operation and linkage adjustment of the factory-installed air damper options.

### Economizer Dampers

Outside air intake is provided at end of the unit, and the return air path is at the bottom of the damper set. As the actuators modulate the outside air damper open, the return air damper closes. Exhaust air exits the unit through the gravity relief dampers provided at the sides of the economizer section.

The damper is set so that the actuator moves through a 90-degree angle to bring the economizer damper from full open to full close (Figure 112). Access to the actuator is from the filler section.

**NOTE:** Do not “overclose” low leak damper blades. The edge seal should just lightly contact the adjoining blade.

The blades will lock up if they are closed so far the seal goes over center.

### Intake Hood Damper (0% to 100% Outside Air)

Units requiring 100% outside air are provided with a rain hood and dampers that can be controlled by a single actuator. The actuator provides two-position control for opening the dampers fully during unit operation and closing the dampers during the off cycle. No unit mounted exhaust dampers are provided. See Figure 112 for operation of the damper.

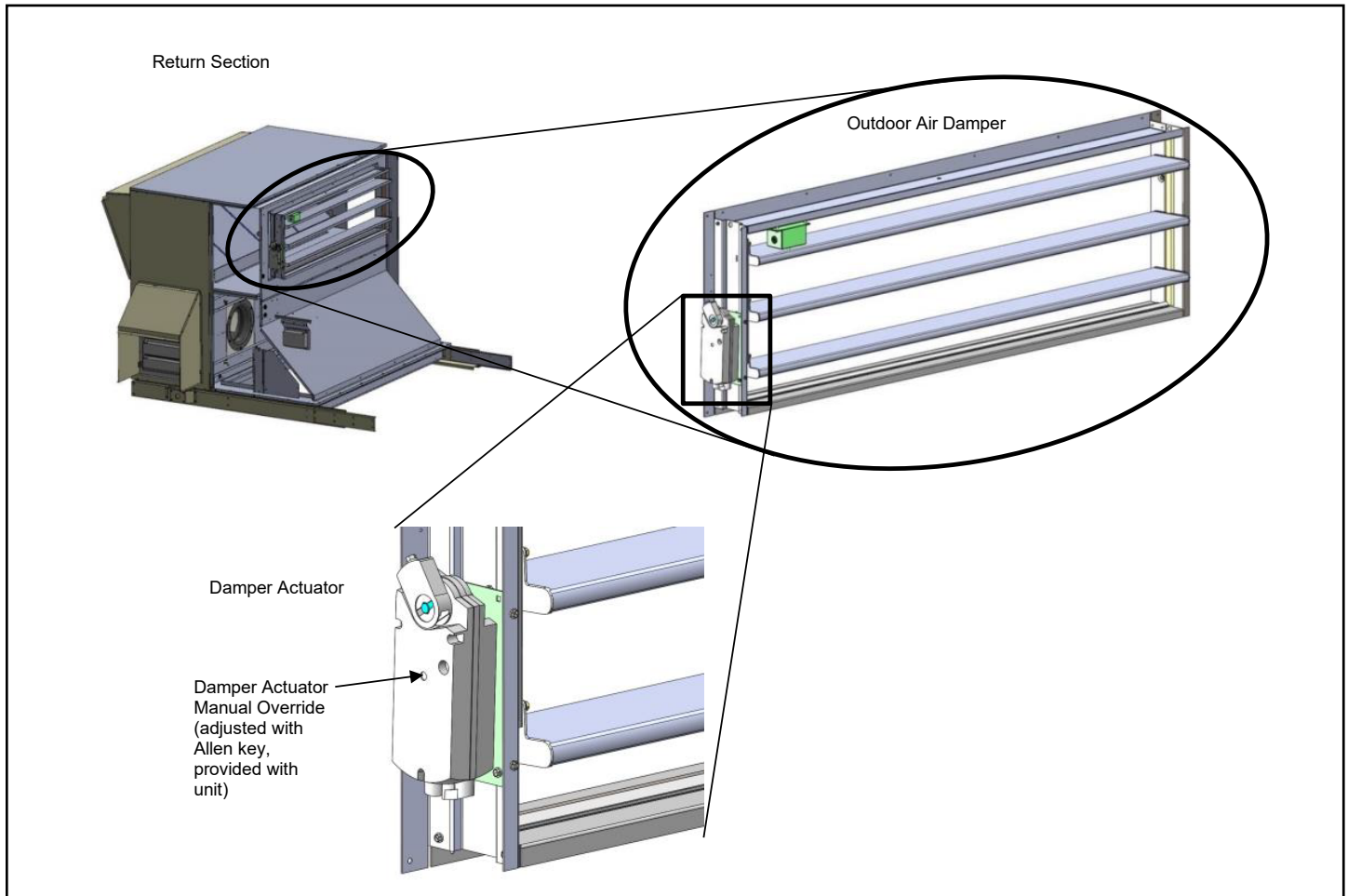
### Intake Hood Damper (0% to 30% Outside Air)

These dampers are intended to remain at a fixed position during unit operation, providing fresh air quantities from 0 to 30% of the total system airflow, depending on the damper setting.

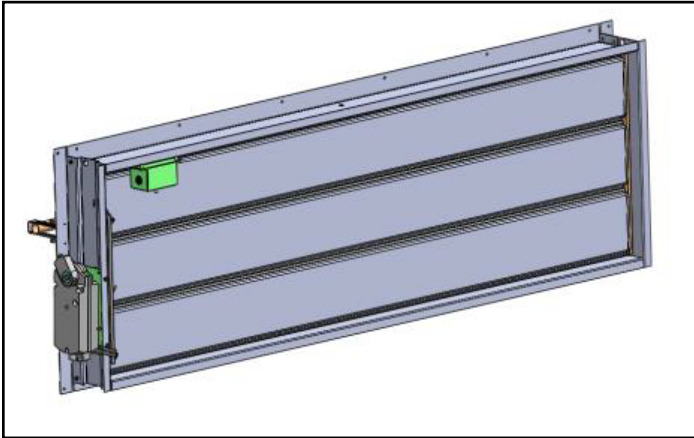
On units provided with MicroTech controls, the damper position may be set at the controller keypad. During unit operation, the analog controlled actuator drives the damper to the position set on the keypad. During the OFF cycle, the damper is automatically closed.

No unit-mounted exhaust dampers are provided with this option.

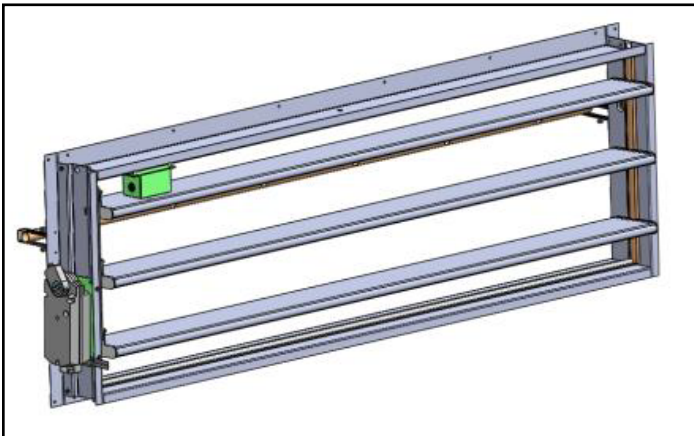
Figure 112: Damper Adjustment



**Figure 113: Intake Hood Damper Adjustment (0% Outside Air)**



**Figure 114: Intake Hood Damper Adjustment (100% Outside Air)**

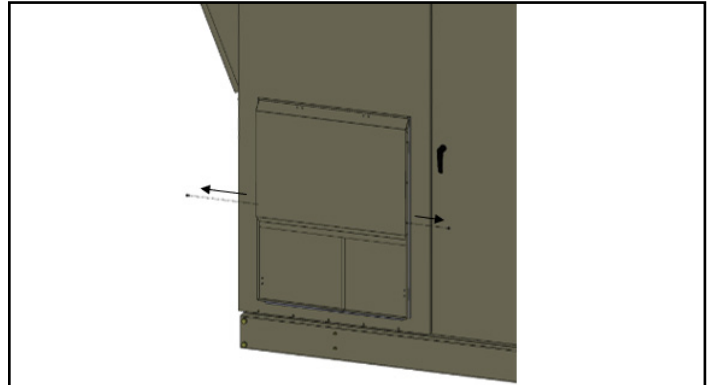


## Exhaust Hood Assembly

On units equipped with exhaust dampers, a hood is provided on the unit and must be set up properly prior to operation. This section describes the procedure for setting up the hood. Failure to complete this set up may cause damage to unit.

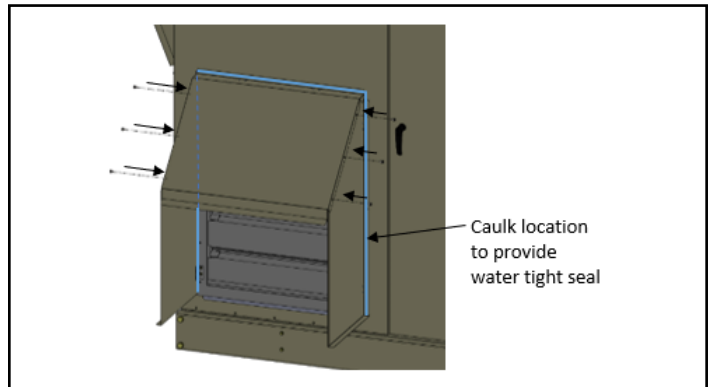
1. As shown in the figure below, the unit is shipped with the hood assembly folded in. To begin set up, remove and retain two shipping screws holding the hood pieces in place.

**Figure 115: Exhaust Hood Folded In**



2. Fold top of hood up.
3. Fold left side and right side out and put screws provided with unit into corresponding holes to lock in position of left side and top of the hood as shown in [Figure 116](#) (reinstall 2 shipping screws and use 4 additional screws provided with unit).
4. Place caulk where shown below in [Figure 116](#) to seal all seams between unit cabinet and hood to create a leak proof water tight seal.

**Figure 116: Exhaust Hood Folded Out**



# HEPA Frame, Filter, and Prefilter Installation

**WARNING**

Sharp edges on sheet metal and fasteners can cause personal injury. Always wear appropriate personal protective equipment (PPE) such as gloves, protective clothing, footwear, eye protection, etc. This equipment must be installed, operated, and serviced only by an experienced installation company and fully trained personnel.

These instructions are for installing AAF HEPA filters (11-1/2 in. depth) into AAF HEPA Holding Frames.

Read the entire installation instructions before beginning the installation process.

Install filters into the HEPA Holding Frames only after the frames have been securely installed into existing ductwork or housing. Frames should be bolted or pop riveted together into the permanent structure through the pre-drilled holes around the outside perimeter of the frames. Frames should be sufficiently caulked and sealed to prevent any air bypass or leakage.

**Required tools for filter installation:**

- T-handle Hex Key, size 5/32 in.

**Framing Components Required:**

- AAF HEPA Holding Frames
  - Daikin Applied PN: 910111491 & 910111674
- Leg Extensions, 4 per frame (A)
  - Daikin Applied PN: 910111494
- Latches, 4 per frame
  - Daikin Applied PN: 910111493 (B) (without prefilters)
  - Daikin Applied PN: 910123164 (C) (with prefilters)
- Prefilter Holding Frames (when prefilters are ordered)
  - Daikin Applied PN: 910123166 & 910123168
- Prefilter Latches (when prefilters are ordered)
  - Daikin Applied PN: 111048304 & 111048305

**Figure 117: Leg Extensions and Latches Without Prefilters (B's and A's)**



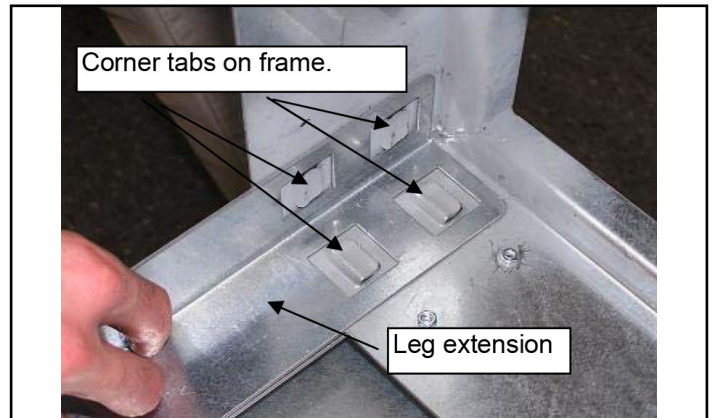
**Figure 118: Leg Extensions and Latches With Prefilters (C's and A's)**



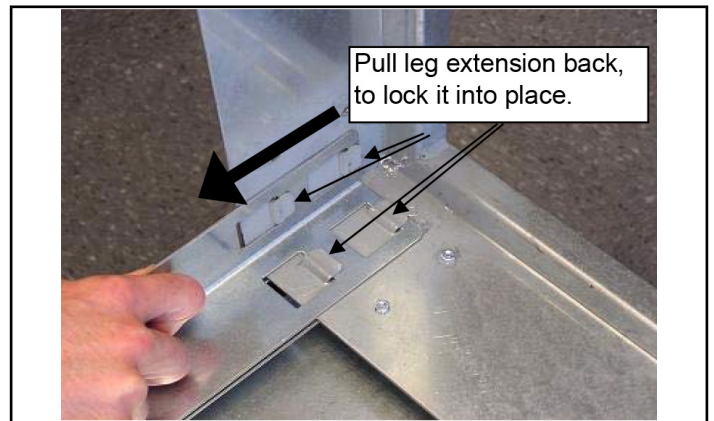
**AAF HEPA Filters without Prefilters**

**STEP 1:** At the inside corner of each frame are 4 tabs, 2 per side. Place a leg extension over the 4 tabs as shown in Figure 119, then pull back on the leg extension locking it into place (Figure 120).

**Figure 119: Place Leg Extension Over the Frame Tabs**



**Figure 120: Pull Back to Lock the Leg Extension Into Place**

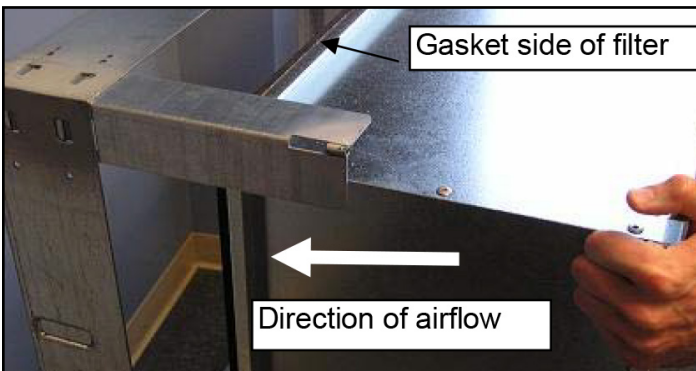


**Figure 121: Frame with Leg Extensions Installed**

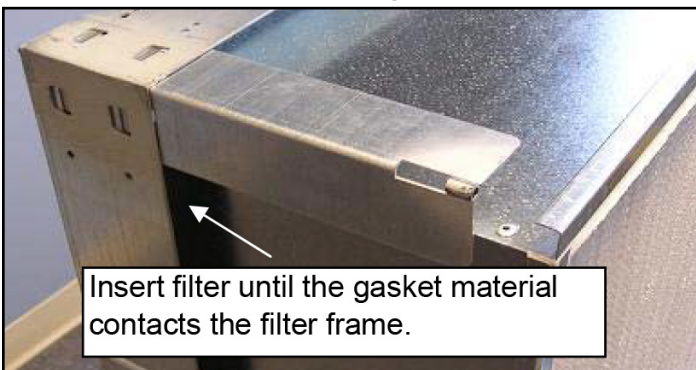


**STEP 2:** Insert the HEPA filter into the HEPA Holding Frame. The HEPA should be installed with the gasket side of the filter facing the frame. Insert the filter as far into the frame as possible, so that the gasket material is contacting the frame. See [Figure 122](#).

**Figure 122: Insert HEPA Filter Into Frame Until the Gasket Comes in Contact With the Holding Frame (1)**



**Figure 123: Insert HEPA Filter Into Frame Until the Gasket Comes in Contact With the Holding Frame (2)**



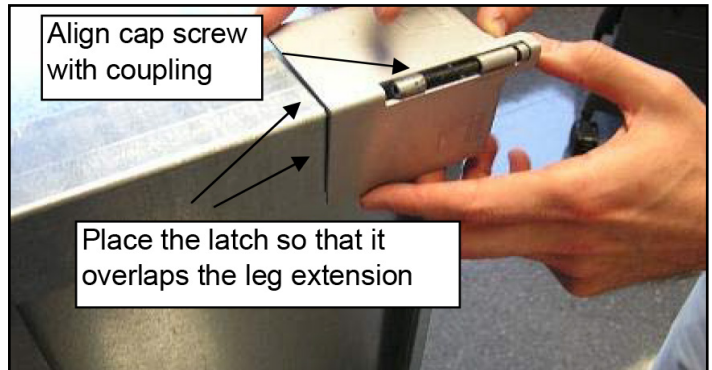
The filter should now be resting inside of the holding frame. When installing the filters into a frame bank of multiple frames, install the lower filters first so that the upper filters can rest on the lower filters ([Figure 124](#)).

**Figure 124: Filter Placed Inside of Frame**

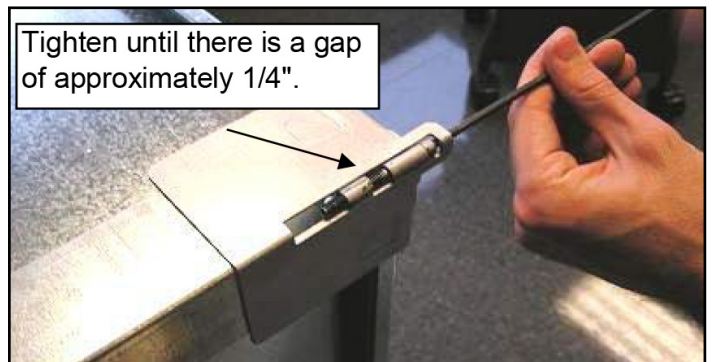


**STEP 3:** Place a latch so that it overlaps the leg extension, as shown in [Figure 125](#). Align the latches' cap screw with the threaded coupling on the end of the leg extension and tighten using the hex key. Tighten the cap screw until there is an approximately 1/4 in. gap between the latch and the leg extension coupling as shown in [Figure 126](#). Repeat this step with all 4 corners.

**Figure 125: Latch Overlapping Leg Extension**



**Figure 126: Tighten Cap Screw to 1/4 in. of the Coupling**

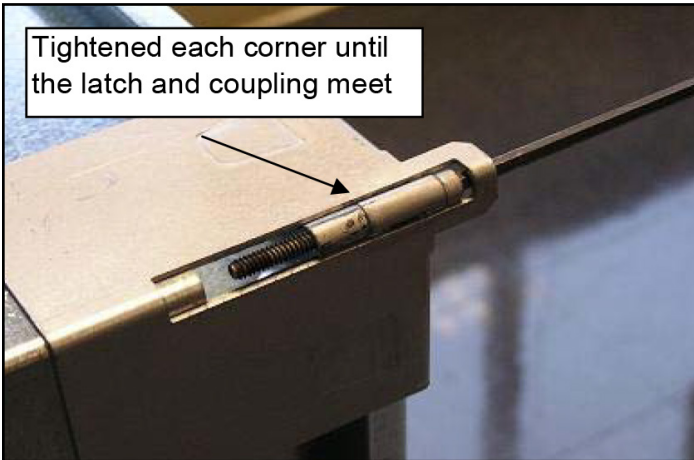


**STEP 4:** Once all four corner latches have been tightened within 1/4 in. of the leg extension coupling, complete the installation by tightening each corner until the latch and leg extension coupling meet. This is illustrated in [Figure 127](#).

Once all four corners have been tightened the filter should now be properly seated and sealed.

Repeat the process with all remaining filters working from the bottom to the top.

**Figure 127: Tighten Until Latch and Coupling Meet**



**Figure 128: Properly Installed Filter Inside of the Frame**



## AAF HEPA Filters with Prefilters

Follow previous steps 1-2, then continue straight to step 5.

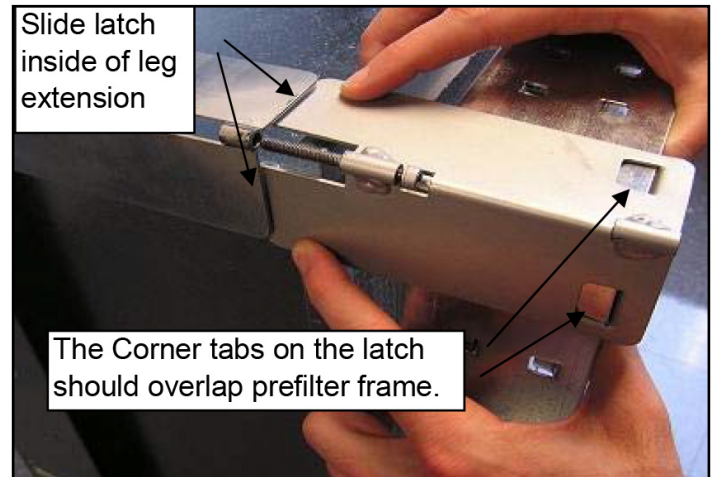
**STEP 5:** The prefilter holding frame should be placed directly in front of the HEPA filter as shown in [Figure 129](#).

**Figure 129: Positioning of the Prefilter Frame**



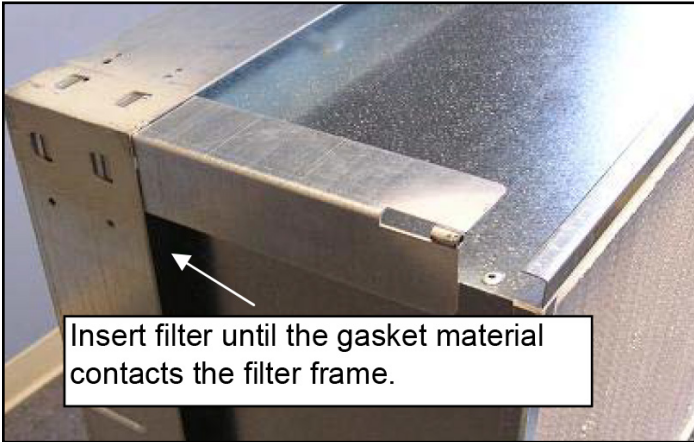
**STEP 6:** Place a latch so that the 2 tabs of the latch overlap the prefilter frame on each side of the corner. Slide the latch inside of the leg extension and align the latches' cap screw with the threaded coupling on the end of the leg extension and tighten using the hex key. See [Figure 130](#).

**Figure 130: Latch Positioning for Prefilter Frame**



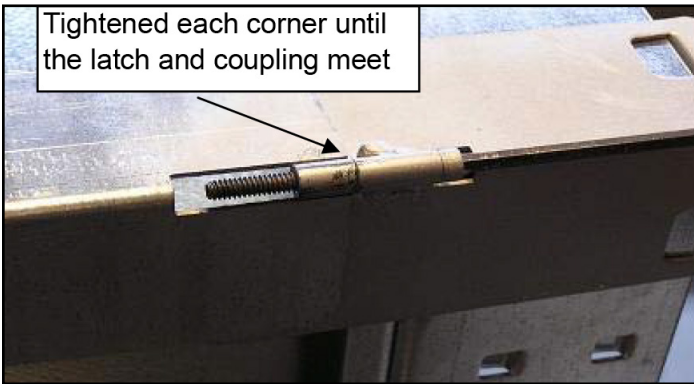
Tighten the cap screw until there is an approximately 1/4 in. gap between the latch and the leg extension coupling as shown in [Figure 131](#). Repeat this step with all 4 corners.

**Figure 131: Tighten Cap Screw to 1/4 in. of the Coupling**



**STEP 7:** Once all four corner latches have been tightened within 1/4 in. of the leg extension coupling, tighten each corner until the latch and leg extension coupling meet. This is shown in [Figure 132](#).

**Figure 132: Tighten until Latch and Coupling Meet**



Once all four corners have been tightened the HEPA filter should now be properly seated and sealed ([Figure 133](#)).

Repeat the process with all remaining filters working from the bottom to the top.

**Figure 133: Properly Installed HEPA Filter**



**STEP 8:** To complete the installation, add the appropriate prefilter latches to the prefilter holding frame ([Figure 134](#)). Once latches are installed, place the prefilter in the frame, secure with the latches and the installation is complete ([Figure 135](#)).

Repeat with all remaining prefilters and frames.

**Figure 134: Installation of Prefilter Into Frame**



**Figure 135: Completed Assembly**



## Installing Ductwork

**⚠ WARNING**

Mold can cause serious illness or property damage. Materials such as gypsum wallboard can promote mold growth when damp. Such materials must be protected from moisture that can enter units during maintenance or normal operation.

On bottom-supply/bottom-return units, if a Daikin Applied roof curb is not used, installing contractor should make an airtight connection by attaching field fabricated duct collars to the bottom surface of either the roof curb's duct flange or the unit's duct opening. Do not support the total weight of the duct work from the unit or these duct flanges. See [Figure 136](#).

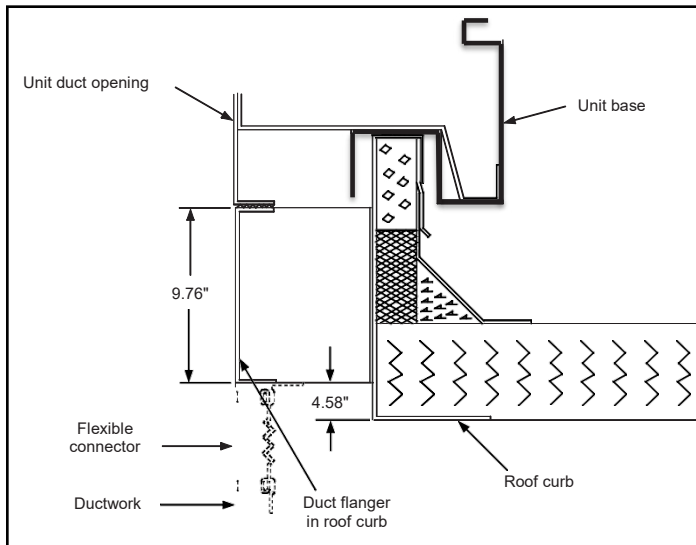
Use flexible connections between the unit and ductwork to avoid transmission of vibration from the unit to the structure.

To minimize losses and sound transmission, design duct work per ASHRAE and SMACNA recommendations.

Where return air ducts are not required, connect a sound absorbing T or L section to the unit return to reduce noise transmission to the occupied space.

Ductwork exposed to outdoor conditions must be built in accordance with ASHRAE and SMACNA recommendations and local building codes.

**Figure 136: Installing Duct Work**



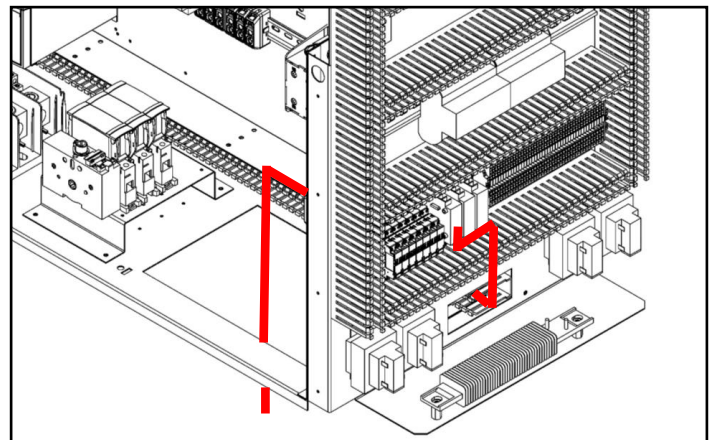
## Installing Duct Pressure Taps

Units that will operate as a VAV unit require a reading of the duct static pressure. This requires that pressure taps and tubing be field provided, installed, and plumbed back to the pressure sensors in the unit. There may be up to two duct static pressure sensors on a unit; DSP1 is provided when the unit is built for VAV operation and an additional sensor DSP2 is optional. When present, these sensors are located within the Low Voltage Control Panel shown in [Figure 3](#) on page 7 and [Figure 137](#).

Carefully locate and install the field provided pressure tap. Improperly locating or installing the DSP1 or DSP2 tap may cause unsatisfactory operation of the building VAV system. Consider the following pressure tap location and installation recommendations. The installation must comply with all applicable local code requirements.

1. Install a tee fitting with a leak-tight removable cap in each tube near the sensor fitting. This facilitates connecting a manometer or pressure gauge if testing is required.
2. Differentiate between the duct pressure (HI) and reference pressure (LO) taps by using different color tubing or by tagging the tubes. Daikin Applied recommends 3/16" I.D. plastic tubing.
3. Locate the duct pressure (HI) tap near the end of a long duct to ensure that all terminal box take-offs along the run have adequate static pressure.
4. Locate the duct pressure tap in a non-turbulent flow area of the duct. Keep it several duct diameters away from take-off points, bends, neckdowns, attenuators, vanes, or other irregularities that may create turbulent air flow.
5. Use a static pressure tip (Dwyer A302 or equivalent) or the bare end of the plastic tubing for the duct tap. (If the duct is lined inside, use a static pressure tip device.)
6. Install the pressure tap so that it senses only static pressure (not velocity pressure). If a bare tube end is used, it must be smooth, square (not cut at an angle) and perpendicular to the airstream.
7. Locate the reference pressure (LO) tap somewhere near the duct pressure tap within the building.
8. If the reference pressure tap is not connected to the sensor, unsatisfactory operation will result.
9. Route the tubes between the curb and the supply duct, feeding them into the Main Control Panel through the Panel Entrance Plate. Connect the tubes to their respective inlets on the appropriate pressure sensor in the Low Voltage Control Panel. See [Figure 137](#) for the suggested routing for the tubing.

**Figure 137: Recommended Tubing Route to Sensors**



## Indoor Air Quality (IAQ) Installations

**WARNING**

POSSIBLE EXPOSURE TO ULTRAVIOLET RADIATION AND HAZARDOUS VOLTAGE!

Failure to disconnect power before servicing could result in severe electrocution or burns leading to serious injury or death. This product contains components that emit Ultraviolet Light radiation (UV-C) which can be harmful to the skin and unprotected eyes, causing severe personal injury. Disconnect all electrical power, including remote disconnects, and ensure UV lights are off before servicing. Follow proper LOCKOUT/TAGOUT procedures to ensure the power cannot be energized while in service.

### Installing UV Lamps

Units equipped with an IAQ section will be shipped with all sheet metal and wiring in place. The UV lamps will need to be installed in the field. The lamps are packaged inside the unit for protection during transit.

- Wear cotton or polyester gloves and safety glasses while handling the lamps.

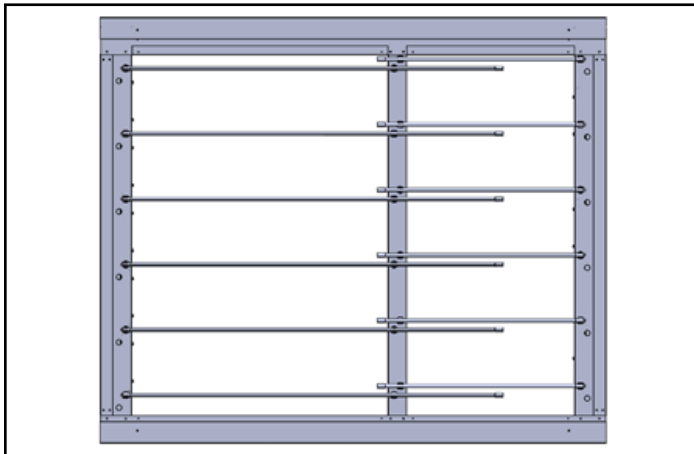
The UV light rack utilizes different lamp lengths to span the entire width inside of the cabinet.

**NOTE:** See “Ultraviolet Lights Option” on page 85 for additional information.

**Table 18: UV Light Rows and Dimensions**

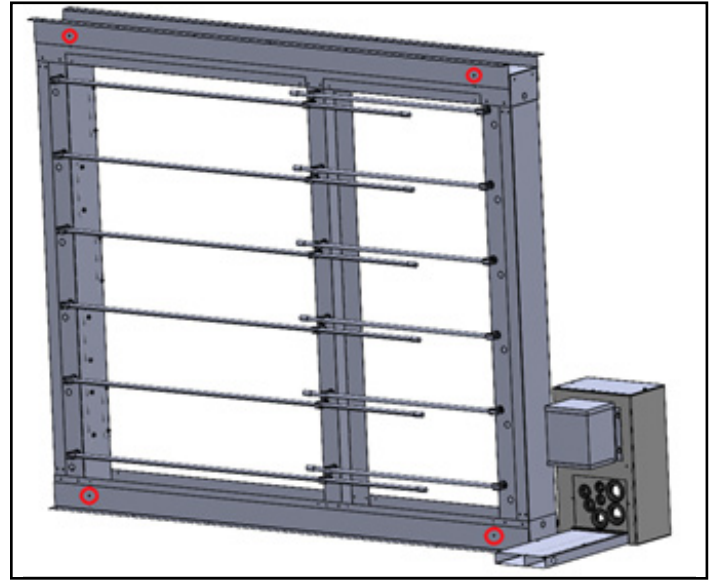
Cabinet Size	Rows	Size (Quantity)
A	4	33 in. (1) 61 in. (1)
B	6	
C	8	48 in. (1)
D		61 in. (1)
E	14	61 in. (2)

**Figure 138: Front View of IAQ Section (facing downstream)**



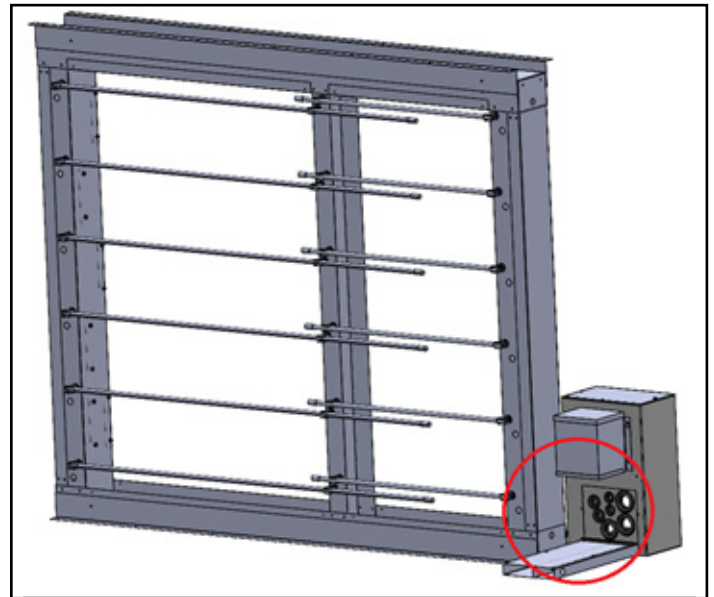
The IAQ sheet metal rack is held into place with 4 screws to secure it to the air handler. To ease the installation of UV lamps, unscrew these 4 fasteners at the corners of the rack as detailed in Figure 139. After the fasteners are removed, disconnect the power at the base of the right side of the rack as seen in Figure 140.

**Figure 139: IAQ Rack Fastener Locations**

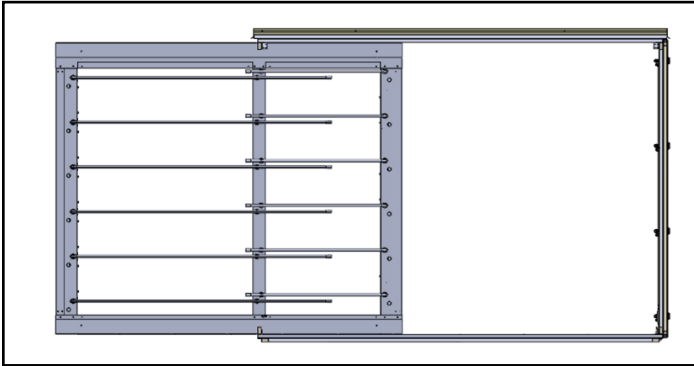


Once the power has been disconnected, slide the rack out of the unit 1/3 of the way so you can access the lamp clips that are the furthest apart while standing outside the unit as seen in Figure 141.

**Figure 140: IAQ Rack Power Location**



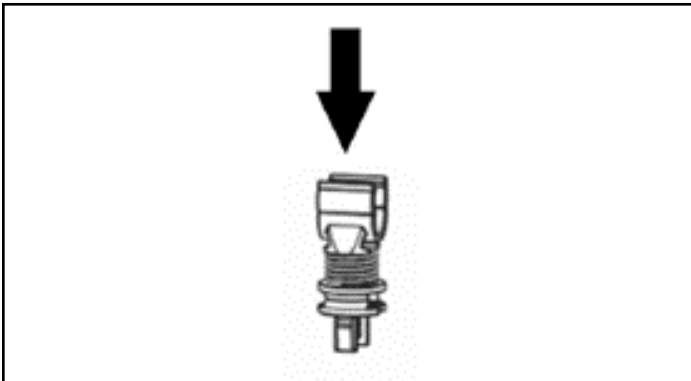
**Figure 141: IAQ Rack Partially Removed for 61 in. Bulb Installation**



- Carefully remove the lamps from the packaging and install them one at a time. There are black lamp clips already installed in the sheet metal rack that will be used to hold the UV lamps.
- The 61 in. lamp will be mounted to the clips that are furthest to the left of the unit and the clips in the center of the unit. The 33 in. lamps are staggered above the 61 in. lamp.
- The receiving power connection to the lamp must be facing the outer edge of the unit so that power can easily be connected/disconnected to the lamp. This connection has 4 pins on it and is on the end of the bulb.

Place the UV lamp evenly between the two clips and press the bulb into the center of the spring clip until the bulb is held firmly in the center semicircle. When pressing the bulb into the clip, apply pressure to the lamp directly above the clip to prevent fracturing the lamp as detailed in [Figure 142](#).

**Figure 142: Spring Clip Handling**

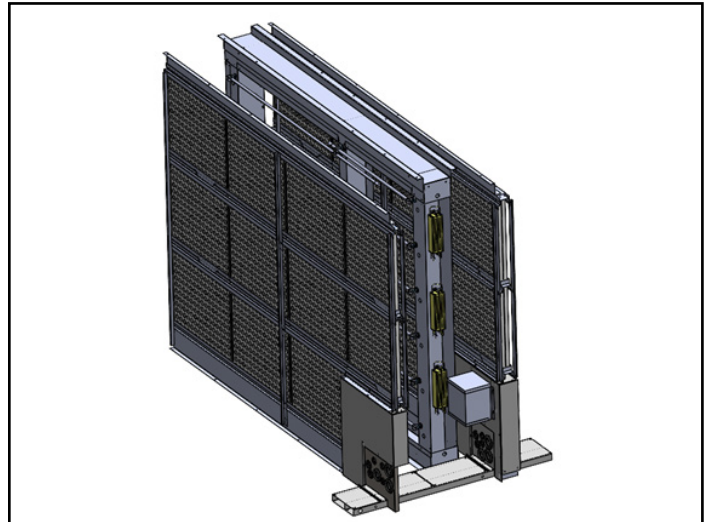


Once the bulb is installed into the clip, connect the wire harness to the end of the bulb. The wire harness is shielded by a flexible metal conduit and will already be installed in the unit. There will be one power harness per bulb.

## Installing PCO Panels and Carbon Filters

- Photocatalytic oxidation panels (PCO) are located upstream and/or downstream of the UV lights depending on the option configured in the unit.
- PCO panels and carbon filters will slide into a traditional filter rack downstream of the UV lights, where there will be a 2 in.-wide filter rack as seen in [Figure 143](#).
- PCO panels should be mounted upstream of the carbon filters. Carbon filters should be replaced at the same interval as the coil pre filters.
- PCO panels will require cleaning once a year or more if there is excess buildup of particulate on the panels. Wash with low pressure water and leave to air dry. Once all panels are dry, they can be reinstalled in the unit.

**Figure 143: IAQ Rack with PCO Panels Upstream and PCO Panels and Carbon Filters Downstream of UV lights**



## Replacing UV Light Bulbs

Ultraviolet bulbs should be replaced after 9,000 hours of use or annually, even if the bulbs still emit light. The blue light emitted from the bulb is not an indication of UV intensity. The UV light intensity emitted from the bulbs degrades over time and will no longer provide the same disinfection benefit. Replacement bulbs must be the exact same size and from the same manufacturer.

1. Disconnect power to unit and UV lamps.
2. Disconnect power harness at the base of the sheet metal rack holding the UV lamps.
3. Disconnect metal conduit power harness connected to the UV lamp.

4. For 33 in. bulbs, remove lamps from the right side of the unit. The 61 in. bulbs should be removed by unscrewing the 4 fasteners at the top and bottom corners of the sheet metal rack, disconnecting the power at the base of the right side, and then sliding the sheet metal rack 1/3 of the way out of the unit. Having the sheet metal rack partially removed from the unit allows for easier removal of the 61 in. lights.
5. Once all bulbs are installed and connected to a power harness, slide the rack back into the unit and reinstall the 4 mounting screws on the corners. Reconnect the power harness at the bottom right corner of the rack.

### Indoor Air Quality (IAQ) Sensors

The IAQ sensor package includes 3 sensors (2 indoor sensors and 1 outdoor sensor). The indoor sensors are placed in the return and supply sections of the unit. The outdoor sensor is located in the economizer section.

The expected life of the sensors is 10 years, after which replacement is recommended.

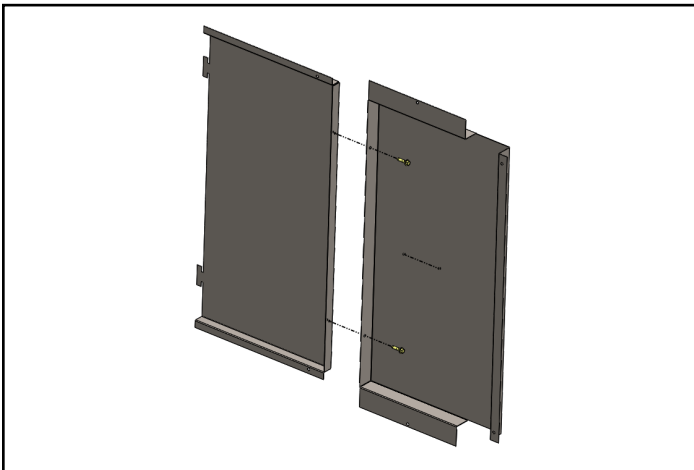
### Fan Block-off Plates

Optional fan block-off plates may be ordered to help maintain reduced capacity functionality in the case of a supply or return fan failure. A until replacement can be procured and installed. Fan block-off plates come in two styles, upstream and downstream. Plates are stored on the inside of one of the air tunnel access doors.

#### Upstream Fan Block-off Plate

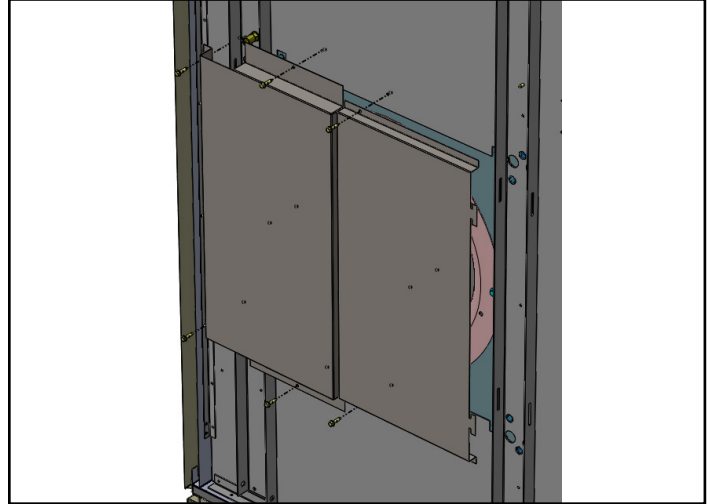
Upstream fan block-off plates are an option that can be assembled and applied without having to remove the failed fan. This block-off plate comes in two pieces which can be assembled outside the unit with the screws provided and installed on the upstream side of the fan bulkhead. [Figure 144](#) shows the proper assembly of the two pieces.

**Figure 144: Upstream Block-off Plate Assembly**



Once assembled, the upstream block-off plate can be installed into the unit to cover the inlet of the fan opening. The failed fan can be left in place for storage until a replacement fan can be installed. [Figure 145](#) shows the proper installation of the upstream fan block-off plate.

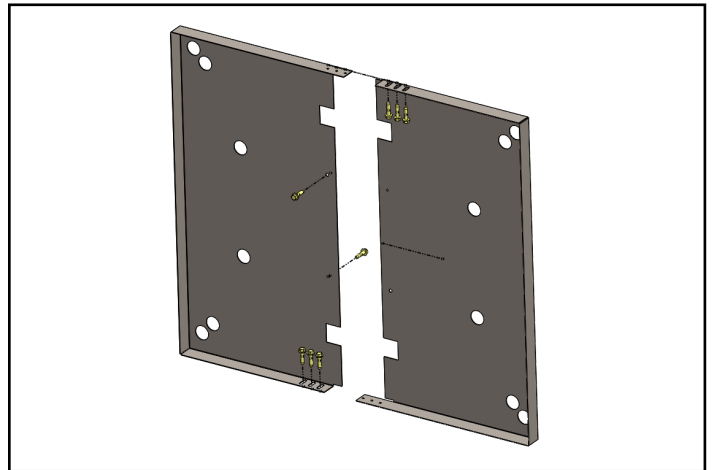
**Figure 145: Installing Upstream Block-off Plate**



#### Downstream Fan Block-off Plate

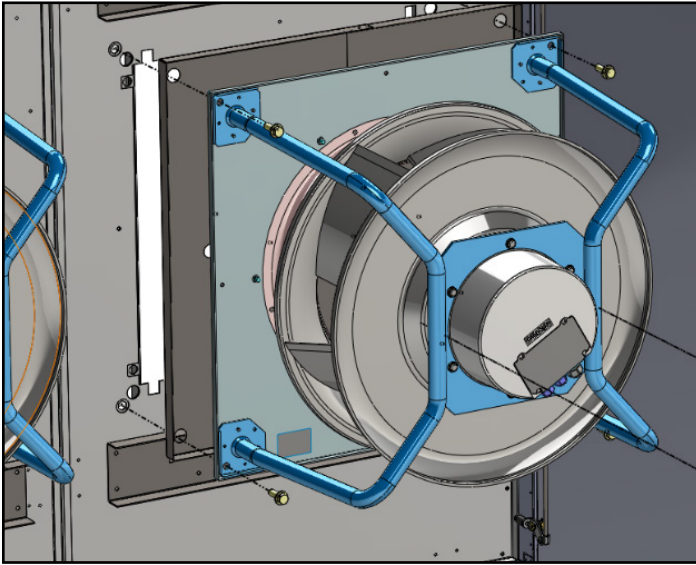
Downstream fan block-off plates are an option that requires removing the failed fan. This block off plate comes in two pieces which can be assembled outside the unit with the screws provided and installed on the downstream side of the fan bulkhead. [Figure 146](#) shows the proper assembly of the two pieces.

**Figure 146: Downstream Block-off Plate Assembly**



Once assembled, the downstream block-off plate can be installed in the unit, on the downstream side of the fan wall bulkhead. The failed fan must be removed in order to install the downstream block-off plate. However, as an added feature, the failed supply fan can be reinstalled over the block-off plate, if it is deemed more convenient for storage purposes (see [Figure 146](#)).

**Figure 147: Installing Downstream Block-off Plate**

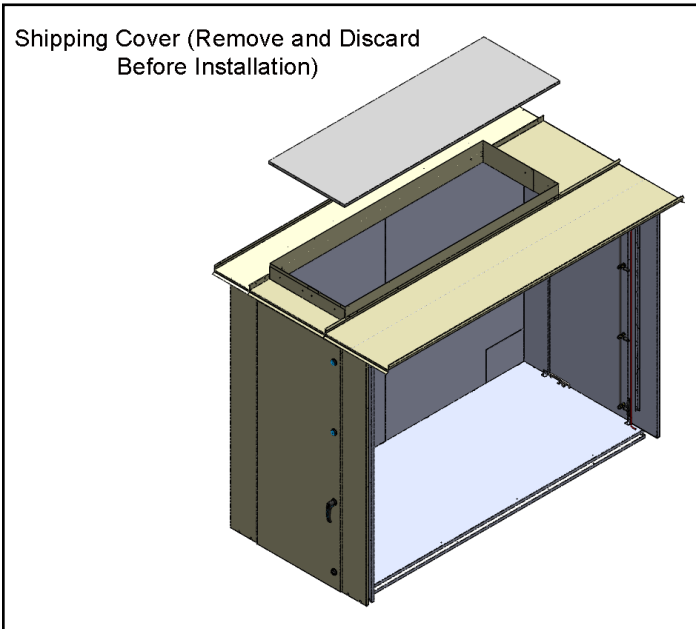


## Top Discharge

On units that are in the top discharge configuration, it is the installer's responsibility to ensure there can be no leakage at or around the duct collar, or the applied ductwork. Leak proof sealant is applied at the factory, however, additional sealant or waterproof tape should be added at installation to ensure no leakage occurs.

Figure 148 below shows the duct collar of a top discharge unit and surrounding joints and seams to be inspected and sealed.

**Figure 148: Top Discharge Opening**



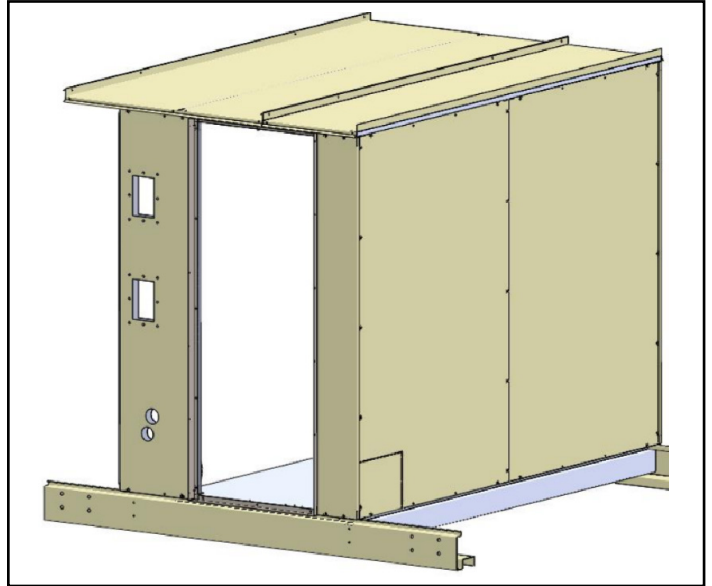
## Side Discharge

On units that are in the side discharge configuration, the same rules as top discharge for unit leakage apply. It is the installer's responsibility to ensure there can be no leakage at or around the duct collar, or the applied ductwork.

Additional support must be given to ductwork to avoid the deformation of the duct collar and damage to the unit.

Figure 149 below shows the duct collar and surrounding area of a side discharge unit.

**Figure 149: Side Discharge Opening**



### CAUTION

Use caution when removing shipping cover and installing duct work. Damage to top panels in this area could cause leaks that could cause damage to unit and building. Inspect all seams and apply sealant and/or waterproof tape to seams prior to operation.

## Installing Building Static Pressure Sensor Taps

**CAUTION**

Use caution when removing tubing from the fragile pressure sensor fitting. Do not use excessive force or wrench the tubing back and forth when removing the tubing. Excessive force and motion can break off and damage the sensor.

Units that are selected with the capability for direct building static pressure control require a reading of the building static pressure. This requires that pressure taps be field installed and plumbed back to the Building Static Pressure sensor (BSP) in the unit. When present, the BSP sensor is found in the Low Voltage Control Panel.

Carefully locate and install the field provided pressure taps. Improperly locating or installing the BSP pressure taps may result in unsatisfactory operation. Consider the following pressure tap locations and installation recommendations. The installation must comply with all applicable local code requirements.

1. Install a tee fitting with a leak-tight removable cap in each tube near the sensor fitting. This facilitates connecting a manometer or pressure gauge if testing is required.
2. Differentiate between the building pressure (HI) and outdoor pressure (LO) taps by using different color tubing or by tagging the tubes. Daikin Applied recommends 3/16" I.D. plastic tubing.
3. Regardless whether the pressure in the controlled space is to be positive or negative with respect to its reference, the building pressure tap will be the HI pressure tap on the Building Static Pressure sensor.
4. Locate the building pressure (HI) tap in the area that requires the closest control. Typically, this is a ground level floor that has doors to the outside. The location must not allow the reading to be influenced by any source of moving air (velocity pressure). These sources may include air diffusers or outside doors.
5. Route tubing between the building pressure tap and the Building Static Pressure sensor (HI) tap. The tubing should be routed between the curb and the supply duct, entering into the Main Control Panel through the Panel Entrance Plate. See [Figure 137 on page 65](#) for the recommended route for field installed tubing to the BSP.

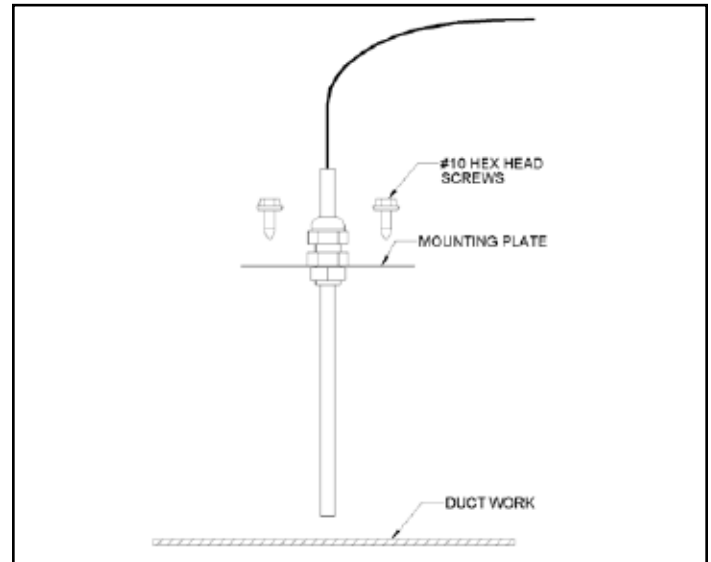
6. Locate the reference pressure (LO) tap in the area surrounding the controlled space. Improperly locating the reference tap may result in unsatisfactory operation.
7. If the reference pressure (LO) tap is to be located outside, locate it away from condenser fans, walls, or anything else that may cause air turbulence. The reference pressure (LO) tap must be mounted high enough above the roof or ground so that it is not affected by snow. Additionally, use an outdoor static pressure tip (Dwyer A306 or equivalent) to minimize the adverse effects of wind. Place some type of screen over the sensor to keep out insects. Loosely packed cotton works well.
8. Route tubing between the reference pressure tap and the Building Static Pressure sensor (LO) tap. The tubing should be routed between the curb and the supply duct, entering the Main Control Panel through the Panel Entrance Plate. See [Figure 3 on page 7](#) and [Figure 137 on page 65](#) for the recommended route for field installed tubing to the BSP. Seal the penetration to prevent water from entering.

## Installing Discharge Air Temperature Sensor

The discharge air temperature sensor should be installed in the supply air duct downstream of the rooftop unit. Locate the sensor at a location that approximates the average duct temperature. Generally, locate the sensor 5-10' from the unit discharge and after one duct turn to allow for air mixing. Do not install downstream of VAV boxes or other dampers.

1. Drill a 7/8 in. Diameter hole in the duct, insert the temperature probe and secure plate to duct using 2-#10 screws.
2. Be sure to apply gasket or sealant to back of mounting plate prior to screwing the plate to the duct to create an air tight seal.

**Figure 150: Temperature Sensor Installation**



# Unit Wiring

## Field Power Wiring

**⚠ DANGER**

LOCKOUT/TAGOUT all power sources prior to wiring or servicing the unit. Hazardous voltage can cause serious injury or death. Disconnect electric power before servicing equipment. More than one disconnect may be required to de-energize the unit.

**⚠ DANGER**

Dangers indicate a hazardous electrical situation which will result in death or serious injury if not avoided.

**⚠ DANGER**

Proper line voltage and phase balance must be provided. Improper voltage or excessive phase imbalance may result in severe damage to the electrical components within the unit.

**⚠ CAUTION**

Miswiring field-installed accessories or sensors can damage the controller. Do not deviate from the prescribed wiring directions.

**⚠ CAUTION**

All penetrations made through control panel knockouts must be sealed to prevent leaks. Gaps around field conductors and wiring should be sealed using elastic compound. Failure to do so may result in property damage.

For the unit to operate, power must be supplied to the unit through field installed service conductors. Electrical characteristics, such as Unit Voltage, Minimum Current Ampacity (MCA), and Maximum Overcurrent Protection (MOP) are found on the Unit Nameplate. These characteristics must be considered when planning the installation of the service conductors and other applicable field wiring.

**NOTE:** The installation of all field wiring, must comply with all applicable local codes and ordinances. The warranty is void if the field wiring is not in accordance with these standards.

Depending on the unit configuration, the unit will come with either a Fused Disconnect (factory-installed or field supplied), a Non-Fused Disconnect, a power block, or a combination in cases where multiple sources of power are specified. Consult the Unit Specific Electrical Schematics to determine the number of required sources of power. Refer to [Table 19](#) for the standard multiple point power connection options and their function.

**Table 19: Multiple Point Power Connection Options**

Power Sources	Disconnect Designation	Load	Location
2	DS2	Supply and return fan motors plus controls	Main control panel
	DS1	Balance of unit	Main control panel
2	Field Connect	Electric heat	Main control panel
	DS1	Balance of unit	
3	Field Connect	Electric heat	Electric heat control panel
	DS2	Supply and return fan motors plus controls	Main control panel
	DS1	Balance of unit	Main control panel

The point of connection for service conductors will be within the Main Control Panel. However, on some units service conductors may be required to be installed in the Electric Heater Control Panel. Consult the Unit Specific Electrical Schematics to determine if the electric heater will require its own set of service conductors. Refer to [“Daikin Applied Electric Heater Modules” on page 128](#) for service conductor entrance details pertaining to the electric heater.

The recommended entrance for field installed service conductors that terminate in the Main Control Panel is through the Panel Entrance Plate in the bottom right corner of the control panel enclosure. This entrance to the Main Control Panel is shown in [Figure 152 on page 72](#) and also noted in [Figure 151](#).

When planning the installation of the service conductors, consider the information in [Table 20](#), [Table 21](#), and [Table 22 on page 72](#). These tables provide details for the field wired service conductor connections including the number of ports that will be available per phase as well as the range of conductor gauge that they will accept. [Table 20](#) provides this information for non-fused disconnects, [Table 21](#) covers the fused disconnects, and [Table 22](#) details power block ports.

**Table 20: Non-Fused Disconnect Lug Port Details**

Non Fused Disconnect Size	Type 1 Ports			Type 2 Ports		
	Qty	Min AWG	Max AWG	Qty	Min AWG	Max AWG
30	1	#10	2/0	—	—	—
60	1	#10	2/0	—	—	—
100	1	#10	2/0	—	—	—
200	1	#6	300MCM	—	—	—
400	2	1/0	250MCM	1	#4	600MCM
600	2	2	600MCM	—	—	—
800	4	2	600MCM	—	—	—

**Table 21: Fused Disconnect Lug Port Details**

Fused Disconnect Size	Type 1 Ports			Type 2 Ports		
	Qty	Min AWG	Max AWG	Qty	Min AWG	Max AWG
60	1	#14	#6	—	—	—
100	1	#12	#1	—	—	—
200	1	#6	300MCM	—	—	—
400	2	1/0	250MCM	1	#4	600MCM
600	2	2	600MCM	—	—	—
800	2	2	600MCM	—	—	—

**Table 22: Power Block Port Details**

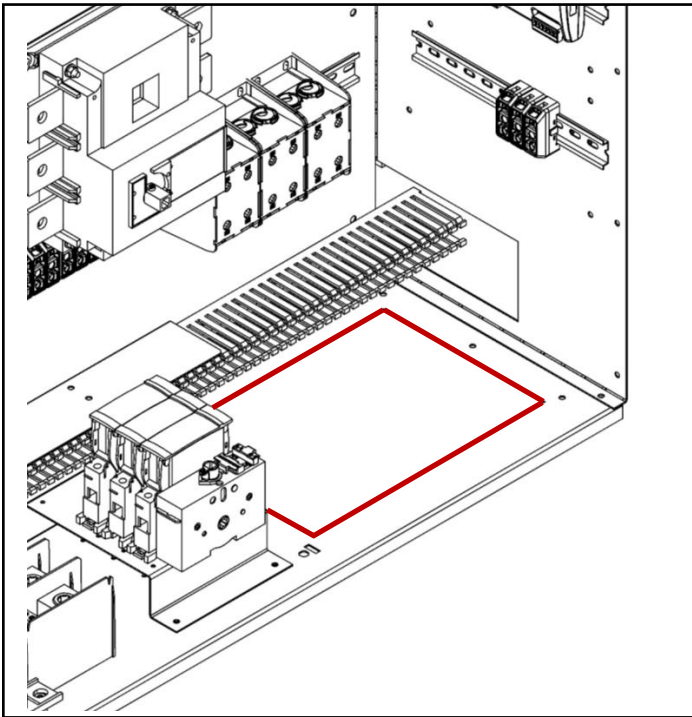
Power Block	Type 1 Ports			Type 2 Ports		
	Ampacity	Qty	Min AWG	Max AWG	Qty	Min AWG
510	1	#2	600MCM	12	#14	#4
760	4	#4	500MCM	—	—	—
950	2	1/0	750MCM	10	#14	2/0

Copper wire is required for all field installed conductors. Supply voltage must not vary by more than 10% of the unit voltage specified on the nameplate. Phase voltage imbalance must not exceed +/- 2%. (Calculate the average voltage of the three legs. The leg with voltage deviating the farthest from the average value must not be more than 2% away.) Contact the local power company for correction of improper voltage or phase imbalance.

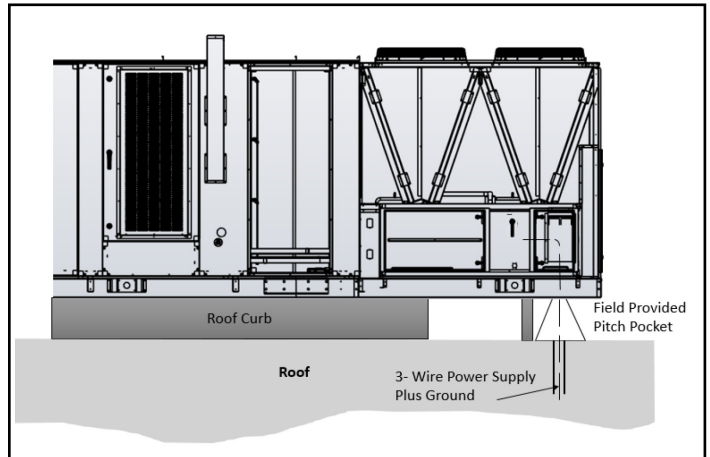
The unit has an option to come with a GFCI service outlet pre-installed in order to satisfy the code requirements of NEC 210.63. If the GFCI or the service lights were selected as field powered, conductors supplying a 115V 20/15A source must be run to terminals in the control panel as shown in the example in [Figure 152](#). These terminals are typically located in the Main Control Panel at the High Voltage Terminal Block, TBHV.

If the GFCI or service lights were selected as unit powered, then no additional wiring must be run beyond the 3 phase service conductors to power the 115V service outlet. Consult the Unit Specific Electrical Schematics to determine the installation requirements.

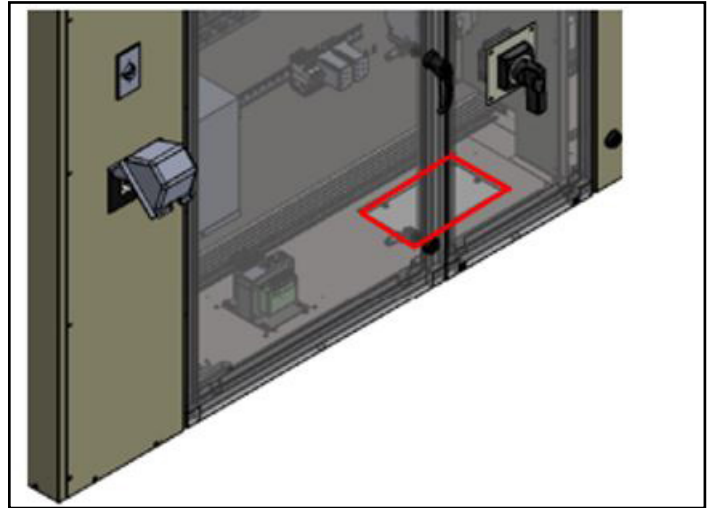
**Figure 151: DPSA Unit - Typical Field Power Entrance – Power Entrance Plate**



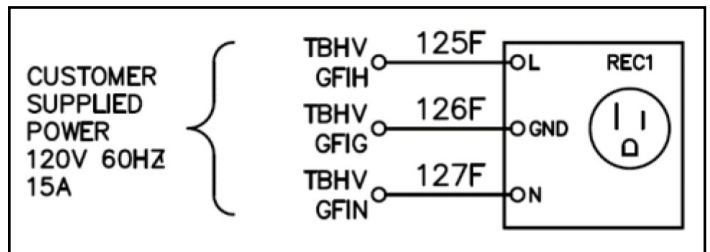
**Figure 152: Typical Field Power Entrance – Main Control Box**



**Figure 153: DAHA Unit - Typical Field Power Entrance - Power Entrance Plate**



**Figure 154: Field Wired GFCI Power**



## Field Control Wiring

**⚠ DANGER**

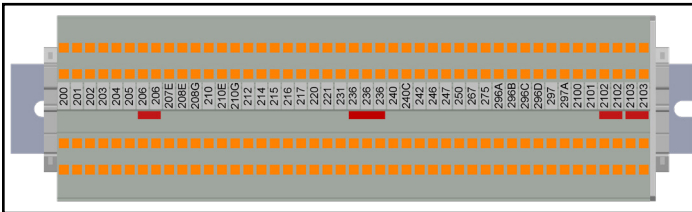
LOCKOUT/TAGOUT all power sources prior to wiring or servicing the unit. Electrical shock hazard that may cause severe injury or death. Connect only low voltage NEC Class II circuits to the terminal blocks. Reinstall and secure all protective front panels when the wiring installation is complete.

**⚠ CAUTION**

Miswiring field-installed accessories or sensors can damage the controller. Do not deviate from the prescribed wiring directions.

Rebel Applied units are available with several control schemes which may require low voltage field wiring. Use the Unit Specific Electrical Schematics to determine which control connections will be required for installation. Check unit specific electrical documentation in the door of the control panel. Figure 155 is a graphical representation of TB2 and Table 23 shows the possible field connections that can be made.

Figure 155: Graphical Representation of TB2



Rebel Applied units operate with 115V and 24V control circuit power. All field control wiring connections are made at the class II terminal block TBLV2 which is located in the Low Voltage Control Panel, shown in Figure 159.

**NOTE:** The installation of all field wiring, must comply with all applicable local codes and ordinances. The warranty may be limited or certain aspects excluded if the field wiring is not in accordance with these standards.

If a single conduit containing 24V and 115V wiring is run above the roofline between units, consider the 24V wiring within as an NEC Class I wiring system.

Table 23: Potential field Connections and Locations on TB2

Terminal Block Number	Description	Signal
200	Power	24VAC
201	Signal for Tennant Override	Contact Closure
202	Condensate Overflow Switch Contact 1	Contact Closure
203	Condensate Overflow Switch Contact 2 & feed into SD2 E-stop series	Contact Closure
204	Feed from SD2 into E-Stop Series	Contact Closure
205	Field Provisions for E-Stop	Contact Closure
206	Field Provisions for E-Stop	Contact Closure
207E	Relative Humidity Sensor #1 (ZRH1)	4-20mA
208E	Humidity Sensor	4-20mA
208G	Relative Humidity Sensor #2 (ZRH2)	4-20mA
210	Space Temperature Sensor 1	Class II Thermistor

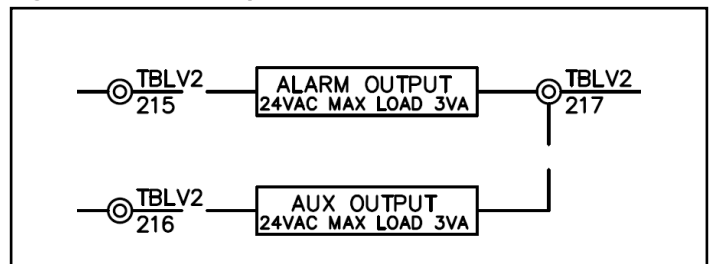
Terminal Block Number	Description	Signal
210E	Space Temperature Sensor 2	Class II Thermistor
210G	Space Temperature Sensor 3	Class II Thermistor
212	Setpoint Adjustment, Wallstat	0-5 VDC Signal
214	CO2 / Ext OA Reset	0-10V DC
215	Alarm Output	24VAC relay
216	Alarm Return	24VAC relay
217	Fan Operation	24VAC relay
220	Freezestat Sensor Terminal 1	Contact Closure
221	Freezestat Sensor Terminal 2	Contact Closure
231	Alarm Reset	Contact Closure
236	Controller Common	
240	Local / Remote Status	Relay output
240C	System Ready Output	Relay output
242	Cooling system Interlock (From Field)	Contact Closure
246	Reheat Valve Cmd	0-10V DC
247	Cooling Capacity Input	0-10V DC
250	Cooling Actual Capacity Output	0-10V DC
267	SAF1 Capacity Cmd (From Field)	0-10V DC
275	EF Capacity Cmd (From Field)	0-10V DC
296A	Return Air SD Aux Contact	Relay output
296B	Return Air SD Aux Contact	Relay output
296C	Supply Air SD Aux Contact	Relay output
296D	Supply Air SD Aux Contact	Relay output
297	Passive Ventilation Input	Contact Closure
297A	Passive Ventilation Input	Contact Closure
2100	Smoke Purge - Purge	Contact Closure
2101	Smoke Purge - Pressurize	Contact Closure
2102	Smoke Purge - Vent	Contact Closure
2103	Smoke Purge - Shutdown	Contact Closure

## Field Output Signals

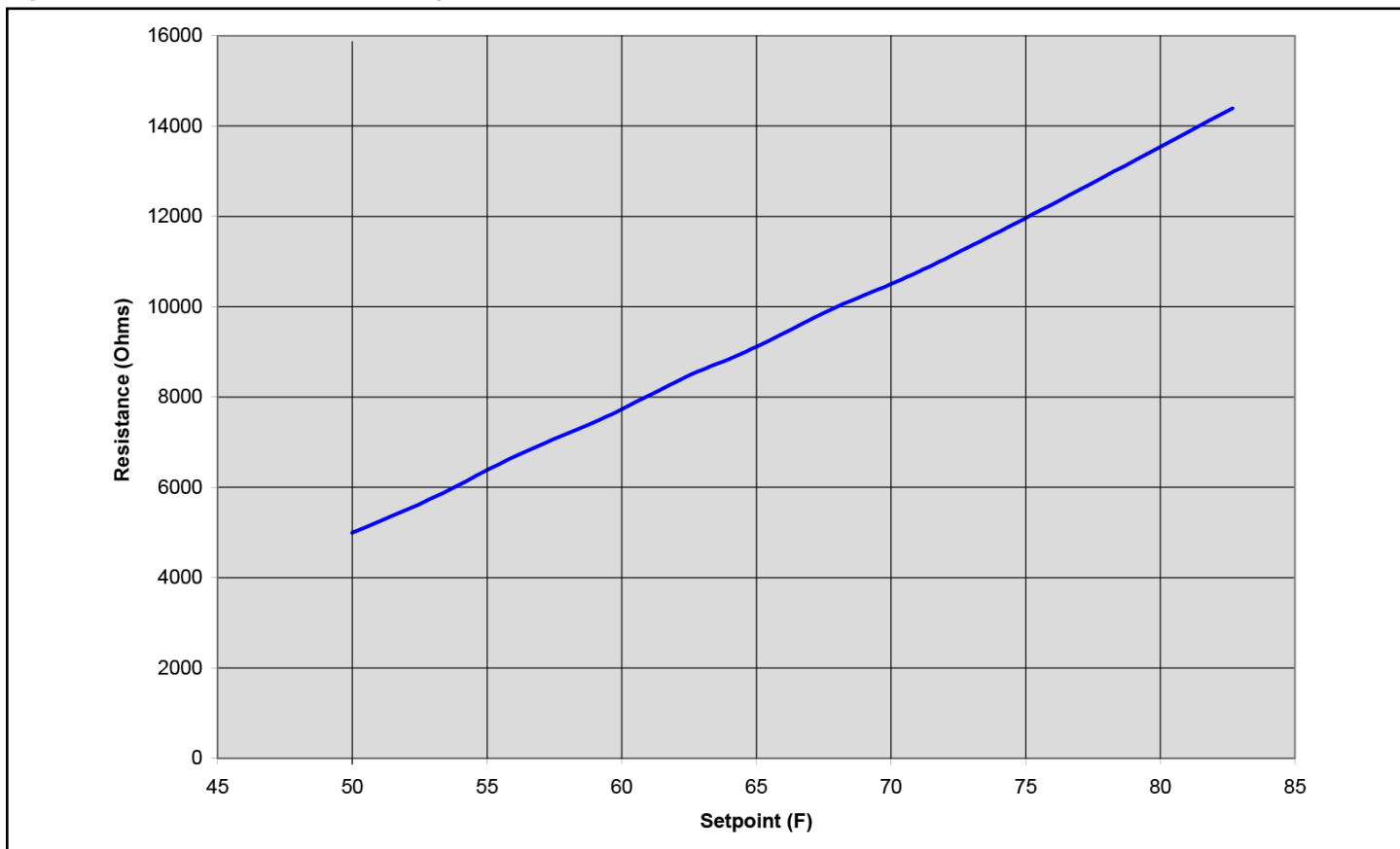
There are several output signals on the MicroTech Controller that may be available for field connections. For example, the Alarm Output and the Auxiliary Output, shown in Figure 156, can be used to send signals to external systems.

A field supplied 24VAC relay must be installed in order to interface these outputs with a system external to the unit. When the respective signal is active, the signal terminal will be energized with 24VAC. The coil of the field supplied 24VAC relay must be wired between the signal terminal and the common terminal. These would be terminals TBLV2-215 and TBLV2-217 in the case of the Alarm Output and terminals TBLV2-216 and TBLV2-217 in the case of the Auxiliary Output. The field installed relay coil may draw no more than 3VA or 125mA at 24VAC.

Figure 156: Field Output Schematic



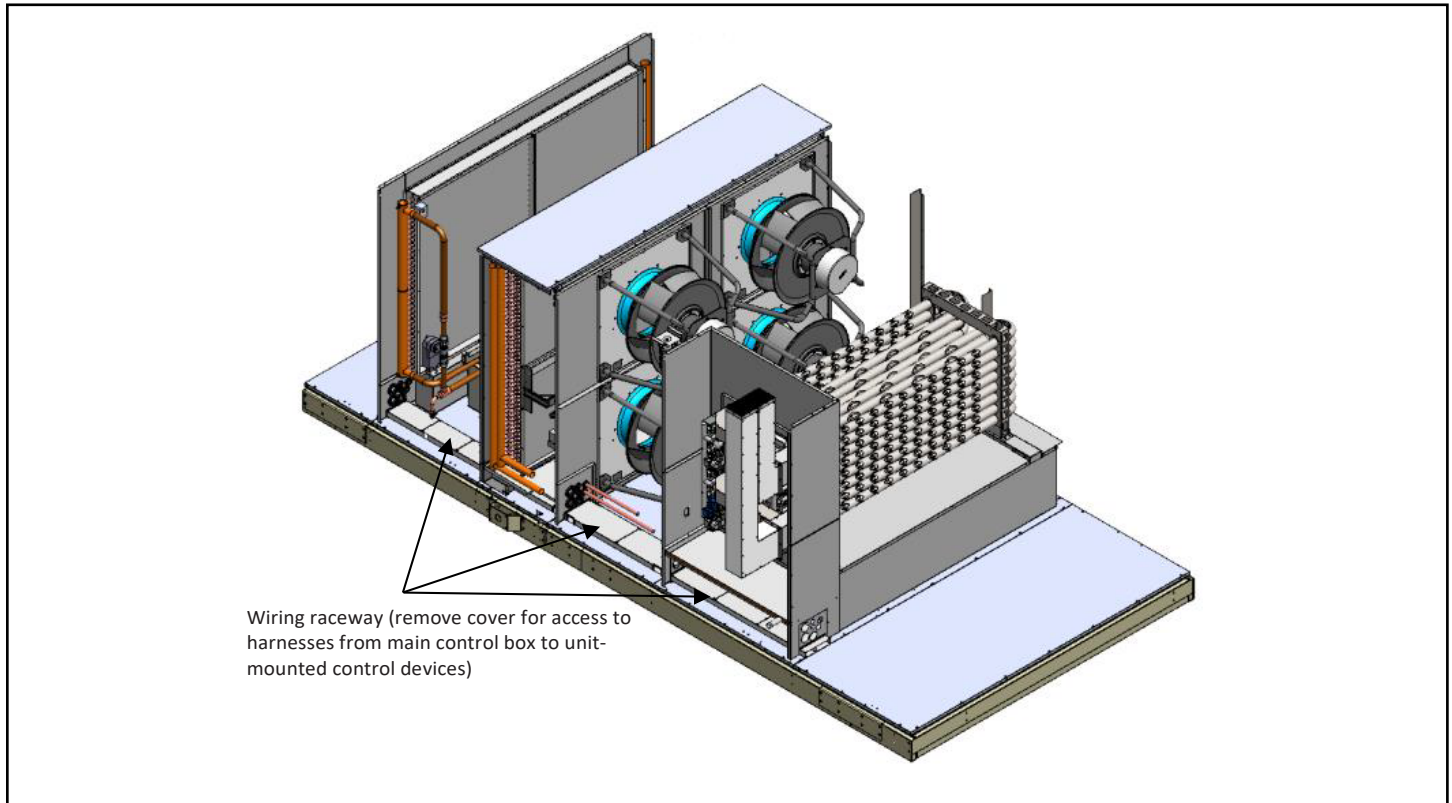
**Figure 157: Wallstat Resistance vs. Setpoint**



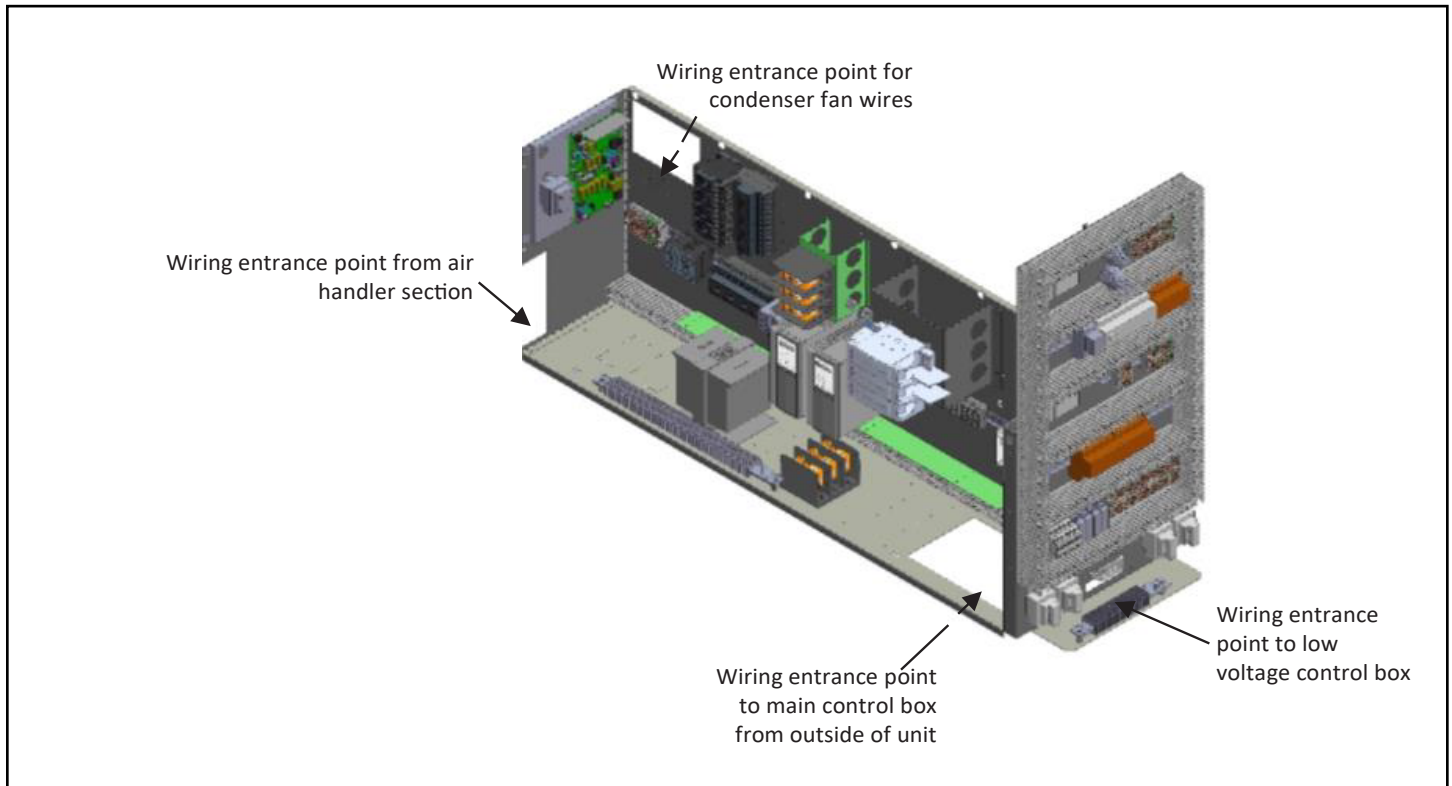
**Table 24: Resistance vs. Temperature for Setpoint Adjustment**

Ohms	T (°F)	T (°C)
5000	50	10
6000	54	12
7000	57	14
8000	61	16
9000	64	18
10000	68	20
11000	72	22
12000	75	24
13000	79	26
14000	82	28
15000	86	30

**Figure 158: Wiring Raceway, Air Handler Sections**



**Figure 159: Wiring Connections Control Box (located in Condenser Section, Shown without Doors or Panels)**



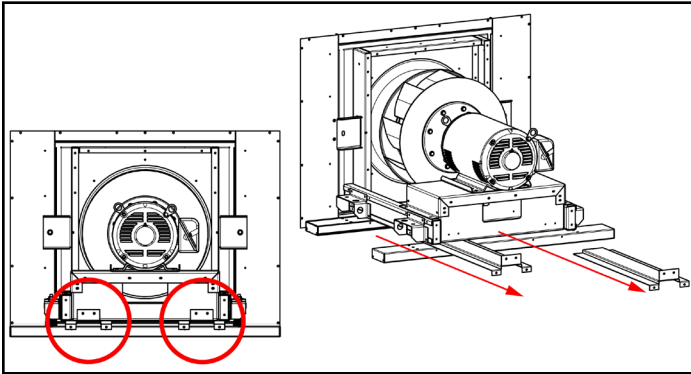
# Unit Operation

## Preparing Unit for Operation

### Supply and Exhaust Fan Shipping Bracket Removal

Supply and exhaust fans are shipped with brackets that must be removed prior to start up. See [Figure 160](#).

**Figure 160: Supply and Exhaust Fan Shipping Bracket Removal**



### Power-up

There is a 115 VAC control circuit transformer and several 24VAC circuit transformers within the unit to control the various loads and sensors within the unit. See as-built schematics that are sent with the unit to familiarize yourself with the various features and control circuits.

**NOTE:** Unit ships with factory installed jumpers in the emergency override circuit on TB2 between terminals 202 and 203.

### Start Up Operating State

When a unit is commanded to start it will always enter the Start Up operating state from the OFF operating state. The unit remains in the Start Up operating state for an adjustable time period (default 180 seconds) before entering the recirculating operating state.

### Recirculating Operating State

During the Start Up, operating state the fans remain off, the outdoor air dampers are driven closed, and variable speed supply air fan's remain at 0%. Cooling and heating are disabled, except for 100% OA heating start sequences. Recirculating Operating State Units with return air always enter the Recirculating operating state after the completion of the Start Up operating state. In the Recirculating operating state fans are started and operate while the outdoor air dampers remain closed. This allows temperature conditions throughout the unit and space to equalize before temperature control begins. Cooling and heating remain disabled. The unit remains in the Recirculating operating state

until the Recirculate State Timer (default 180 seconds) expires.

**NOTE:** 100% outdoor air units do not transition through the Recirculating operating state.

### Fan Only

The unit enters the Fan Only operating state after the recirculation timer expires. Units configured for 100% outside air operation will transition directly from the Start up operating state into the Fan Only operating state. Once entering the Fan Only state of operation the unit will then, based on sensor inputs transition into any of the 4 remaining states of operation - heating, cooling, economizer, or minimum discharge air heating.

### Compressor Start

#### NOTICE

This unit's compressors are pre-charged with oil from the factory. If compressor oil is seen leaking from any components, contact Daikin Applied's Technical Response Center.

Unit is shipped with stiffening brackets attached to all compressor feet to avoid unwanted vibration during transit. These must be removed after unit is set in final position and prior to start up.

### Fan Operation

Within 120 seconds after the fans start, the controller expects to get feedback from the fans (via modbus) that they are operating properly. If the controller does not receive that feedback, the controller assumes the fans did not start. It then shuts down the unit and generates an alarm. Units configured for VAV control, the supply fan(s) is modulated to maintain the duct static pressure setpoint. On VAV units or CAV units equipped with return fan capacity control, the fan(s) is modulated to maintain an acceptable building static pressure.

### Economizer Operation

If the unit is equipped with a 0-100% modulating economizer and the conditions are suitable for free cooling, the unit attempts to satisfy the cooling load by using the outdoor air economizer before using mechanical cooling.

If the unit is configured for Zone Temperature Control the transition to economizer operation will occur if all the following are true:

- The control temperature rises above the occupied cooling set point by more than  $\frac{1}{2}$  the occupied cooling high deadband
- The discharge air temperature is greater than the Min DAT limit by more than  $\frac{1}{2}$  the DAT heating deadband. This will prevent more cold air from being brought in when the DAT is already cold
- The economizer operation is not disabled

If the unit is configured for Discharge Air Temperature Control the transition to Mechanical cooling will occur if all the following are true:

- The control temperature rises above the occupied cooling set point by more than ½ the occupied cooling deadband
- The discharge air temperature is greater than the DAT cooling set point by more than ½ the DAT cooling deadband
- Post heat operation is complete
- Economizer operation is not disabled

## Defrost Mode (Heat Pumps Only)

Heat pumps in heating mode (and in certain conditions) will develop a layer of frost on the outdoor coils which can prevent airflow and reduce performance. Heat pumps come equipped with sensors and control software logic that switches the unit refrigeration circuit into “Defrost Mode” to mitigate the effect of frost on the outdoor coils.

Defrost mode is only active on one refrigeration circuit at a time. If both circuits meet the requirements to initiate defrost, the defrost cycle on the second circuit will not start until the defrost cycle on the first circuit has completed and the circuit has transitioned back into heating mode.

Defrost mode switches the applicable refrigeration circuit into a temporary cooling mode by actuating the reversing valve, which directs hot refrigerant to the outdoor coil, melting the accumulated frost. The melted frost is then collected in a defrost drain pan and directed to a pipe for defrost water management. See “Unit Piping” on page 46 for details on defrost drain connections.

The defrost cycle is triggered when the circuit DFT (outdoor coil temperature sensor) reaches a threshold that is determined by the OAT, which occurs when enough frost has accumulated on the coil such that heat transfer is significantly impacted. The circuit in defrost mode goes through a sequence to ramp down the compressors, switch the reversing valve to the cooling position, and then ramp up the compressors while keeping the outdoor fans off to generate as much heat as possible in the outdoor coils. During the time in which one circuit is in defrost mode, the circuit remaining in heating mode will ramp up to full capacity in order to maintain a DAT as high as possible. Table 25 outlines the expected maximum change in air temperature (between RAT and DAT) while one of the unit circuits is in a defrost mode cycle.

**Table 25: Air Temperature Changes While in Defrost Mode**

Standard Output		
RAT	OAT	Defrost Delta T
42°F-70°F	> 38°F	3°F
42°F-70°F	20°F-38°F	0°F
42°F-70°F	< 20°F	-5°F
High Output		
RAT	OAT	Defrost Delta T
42°F-70°F	> 30°F	3°F
42°F-70°F	15°F-30°F	0°F
42°F-70°F	< 15°F	-5°F

The defrost cycle ends when either the DFT sensor reaches 100°F, the circuit discharge pressure reaches 450 psig, or the timer limit of 15 minutes is reached. Once one of these scenarios occurs, the defrost cycle enters the termination stage where the reversing valve returns to the heating position and the circuit transitions back to heating operation. To prevent freezing of the condensate that collects in the drain pans from the melting frost on the coils, a drain pan heater installed on the bottom of each outdoor coil drain pan is activated for 15 minutes, allowing the collected condensate to flow to the drain pipe.

## Refrigerant Charge

Rebel Applied units have many configurable options that can affect the refrigerant charge. Actual unit charge is on the unit’s data plate found on the outside and inside of the unit’s main control panel. Rebel Applied units use electronic expansion valves that digitally optimize unit efficiency. If a leak is suspected, the full charge should be removed, weighed, and compared against the unit data plate to ensure full evacuation/reclaim of refrigerant.

## Recharging Unit

The entire system must be evacuated using a suitable vacuum pump, and the quality of the vacuum must use a suitable calibrated micron gauge. The criteria for proper evacuation is under 300 microns and decay of not more than 500 microns after 30 minutes.

The crankcase heaters should be on during the evacuation procedure. This will help boil and release any refrigerant trapped in the oil.

## Compressor Operation

### Compressor Configuration - 4 Fixed

In this configuration there are four fixed speed compressors split into two equally sized refrigeration circuits. Two compressor staging methods are available:

CrossLoad = Alternate staging of the compressors between the two circuits leading to a more evenly loading up of the unit. The compressor staging selected is based on staging up the compressors with the least number of run hours first.

LeadLoad = Fully load up one circuit before fully loading up other circuit.

### Compressor Configuration - 1 Variable, 2 Fixed

In this configuration there are three total compressors across two refrigeration circuits.

Circuit #1 contains one variable speed compressor.

Circuit #2 contains two fixed speed compressors.

In this configuration the variable speed compressor is the lead.

### **Compressor Configuration - 1 Two-speed, 2 Fixed**

In this configuration there are three total compressors across two refrigeration circuits.

Circuit #1 contains one two-speed compressor.

Circuit #2 contains two fixed speed compressors.

In this configuration the two-speed compressor is the lead.

### **Compressor Configuration - 2 Variable**

In this configuration there are two variable speed compressors, one on each circuit.

The two compressors operate in parallel (same speed) except when the capacity demand is lower than the capacity provided by both compressors operating at minimum speed (low demand scenarios) or when the unit is operating in dehumidification mode.

### **Compressor Configuration - 2 Variable, 2 Fixed**

In this configuration there are two variable speed compressors and two fixed speed compressors - one of each on each circuit.

The two variable speed compressors operate in parallel (same speed) except when the capacity demand is lower than the capacity provided by both compressors operating at minimum speed (low demand scenarios) or when the unit is operating in dehumidification mode. Fixed speed compressors are switched on only if capacity demand is high enough, with circuit 1 fixed speed compressor being brought online prior to the fixed speed compressor on circuit 2.

### **Compressor Configuration - 2 Variable, 4 Fixed**

In this configuration there are two variable speed compressors and four fixed speed compressors – one variable and two fixed on each circuit.

The two variable speed compressors operate in parallel (same speed) except when the capacity demand is lower than the capacity provided by both compressors operating at minimum speed (low demand scenarios) or when the unit is operating in dehumidification mode. Fixed speed compressors are switched on only if capacity demand is high enough, with circuit 1 and circuit 2 adding compressors in the way that best balances efficiency and capacity demand. The fixed compressor with the least amount of run hours will be turned on first (of the two fixed compressors on each circuit).

In the case where this compressor configuration is used in a high output heat pumps, the last fixed speed compressors on both circuits, referred to as “boost compressors”, will be switched on only when extra capacity is needed in extra low ambient scenarios (<15 deg F).

### **Cross Load - 4 Fixed**

During a call for mechanical cooling, if HP1 is closed, then DO1 on expansion module C closes, energizing the M1 compressor contactor. The M1 auxiliary brings on required condenser fans, liquid line solenoid valve and de-energizes the crankcase heater.

The second stage of cooling is controlled by DO1 on expansion module D. Compressor 2 is on circuit 2 and is brought on in the same manner as compressor #1, as well as the condenser fans, solenoid valve and crankcase heater on the circuit.

The 3rd stage of cooling is controlled by DO2 on expansion module C and brings on compressor 3.

The 4th stage of cooling is controlled by DO2 on expansion module D and brings on compressor 4.

### **Lead Load**

The loading and unloading process is similar except that both compressors in the lead cooling circuit 1 energize before energizing any compressors in lag circuit 2.

### **Phase Voltage Monitor**

The phase voltage monitor protects against high voltage, phase imbalance, and phase loss (single phasing) when any one of three line voltages drops to 74% or less of setting. This device also protects against phase reversal when improper phase sequence is applied to equipment, and low voltage (brownout) when all three line voltages drop to 90% or less of setting. An indicator run light is ON when all phase voltages are within specified limits. The phase voltage monitor is located on the load side of the power block with a set of contacts wired to the 115-volt control circuit to shut the unit down whenever the phase voltages are outside the specified limits.

### **External Time Clock**

You can use an external time clock as an alternative to (or in addition to) the MicroTech controller’s internal scheduling function. The external timing mechanism is set up to open and close the circuit between field terminals 201 and 202. When the circuit is open, power is not supplied to digital input MCB-DI3. This is the normal condition where the controller follows the programmable internal schedule. When the circuit is closed, power is fed to DI3, the MicroTech controller responds by placing the unit in the occupied mode, overriding any set internal schedule

### **VAV Box Signal/Fan Operation Signal**

Digital Output #10 (MCB-DO10) may be selected as either the Fan Operation output or the VAV output via the keypad. The VAV/ Fan Pop selection can be selected by accessing the Unit Setup menu in the Extended Menu section. See “Unit Wiring” on page 71 for details.

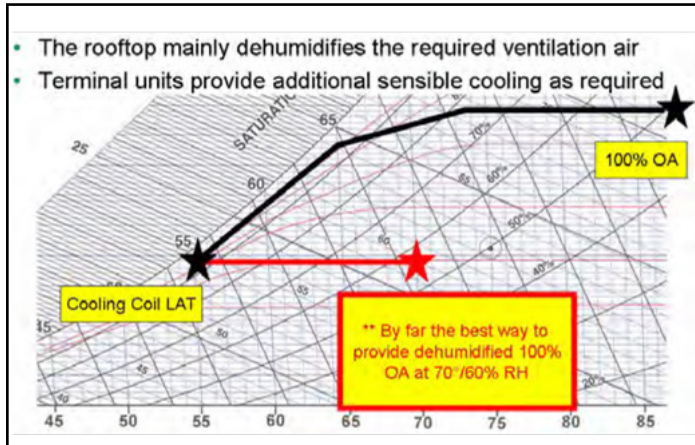
### **Fan Operation**

The Fan Operation output is ON when the unit is not Off and when both the unit is OFF and airflow is detected. It is off when the unit is off and airflow is not detected.

## Dehumidification Operation

In dehumidification mode, mechanical cooling is used to cool air low enough to lower the moisture content of the air and then reheat it to comfort conditions. There are two methods offered in the DPSA product line to accomplish this reheat –modulating hot gas reheat and modulating liquid subcool reheat.

**Figure 161: Ideal for Neutral Air Ventilation Control**



### Modulating Hot Gas Reheat (MHGRH)

Modulating hot gas reheat (MHGRH) systems redirect a portion of the hot refrigerant coming from the compressor(s) on circuit 1 to a coil within the airstream. When there is a call for dehumidification and MHGRH is activated, the compressor(s) on circuit 1 will first be utilized to meet the cooling and dehumidification demand. If the capacity demand cannot be satisfied using only the compressor(s) on circuit 1, the compressors on circuit 2 will be staged to satisfy the remaining demand.

### Modulating Liquid Subcool/Hot Gas Reheat (MLSCRH+MHGRH)

Modulating liquid subcool reheat (MLSCRH) systems redirect a portion of the warm liquid refrigerant leaving the condenser coil on both circuits to a reheat coil within the airstream as shown in [Figure 10](#) and [Figure 11](#). Due to the increased subcooling effect with this option, MLSCRH can increase the unit gross capacity up to 20% depending on operating conditions. When there is a call for dehumidification and MLSCRH is active, the compressors will stage/modulate accordingly to meet the leaving DX coil temperature setpoint and modulate refrigerant to the liquid reheat coil to meet the leaving unit temperature (DAT) setpoint. If the DAT setpoint cannot be satisfied by MLSCRH only, MHGRH will then be activated to assist in meeting the DAT setpoint.

**NOTE:** MLSCRH not available for heat pump units.

### Dehumidification Initiation

An analog sensor is mounted in the return duct, the space, or outdoors to sense Relative Humidity. The location is selected by setting the Sensor Location value on the keypad to Return, Space, or OAT. OAT can only be selected for units with DAT control. Dehumidification is disabled when the unit is in either the Heating or Minimum DAT state. When Dehumidification is enabled, Dehumidification operation is initiated when Humidity Control is set to either Relative Humidity or Dew Point and that value rises above the appropriate setpoint by more than half its dead band. Economizer operation is disabled in the Dehumidification mode, so the unit immediately transitions to Cooling if Dehumidification is initiated in Economizer state.

### Dehumidification Termination

Dehumidification is terminated if the selected variable, Relative Humidity or Dew Point, drops below the appropriate humidity setpoint by more than half its dead band. Dehumidification is also terminated if cooling is disabled for any reason or the unit enters either the Heating or Minimum DAT state. For units with compressors, the number of cooling stages is reduced by one and control reverts to normal control when dehumidification is terminated in the Cooling state. Another compressor stage change could then occur after one Cooling Stage Time has elapsed.

## MHGRH Control & Arrangement

In conjunction with dehumidification, MHGRH is used to raise the temperature of the cooled air to a desirable value without auxiliary heat. MHGRH is comprised of a parallel coil arrangement, with both the condenser and reheat coils of the micro channel type, three-way modulating reheat valve and dual check valves. MHGRH components will always be installed in circuit #1.

During Dehumidification control with modulating Hot Gas Reheat (MHGRH) is done via MicroTech output signal from the main unit controller as described below.

- A PI Loop is used to control the MHGRH valve to maintain the Discharge Air Temperature from the reheat coil.
- Compressor staging during reheat (or dehumidification) will be controlled by the Leaving DX Coil Temperature. For increased dehumidification during reheat, the standard default compressor staging range is 45 - 52°F.
- When dehumidification is active in the Cooling state, the reheat set point equals the DAT Cooling Setpoint. For DAT units, this is the normal DAT set point resulting from any reset. For Zone Control units, this set point is the result of a PI Loop based on the Control Temperature.
- Communication with the reheat control valve is accomplished by providing a Modbus signal to control the reheat valve (stepper type).
- In the Fan Only state, no sensible cooling is required, but the dehumidification mode will still be enabled if the dew point or humidity sensor is not satisfied. In this case the reheat set point varies from a maximum value (default 65°F) when the Control Temperature is at or below the heating

changeover setpoint to a minimum value (default 55°F) when the Control Temperature is at or above the cooling changeover setpoint.

- Lead/Load Arrangement with MHGRH
  - When MHGRH is active, circuit #1 will lead and load up before starting circuit #2.
  - For reheat operation, compressor(s) in circuit #1 must be active. If the unit is operating in the cooling mode when a call for dehumidification/reheat arises, circuit #1 will become the lead and the controller will bring on one additional stage of cooling for dehumidification. If any compressors in circuit #2 are operating at this moment they will be switched over to compressors in circuit #1. Dehumidification operation is disabled if circuit #1 is disabled for any reason.
- In the reheat mode, the minimum position for the reheat valves is 10%. The controller will modulate the reheat valves from this starting position.
- Maximum reheat signal is 85%. This will allow for the outdoor condenser to remain active in the circuit and assist with condenser pressure control.
- Reheat Capacity Limiting Feature is activated if the unit is at maximum reheat (85%) and cannot achieve DAT setpoint (minus ½ dead band) and if any compressor(s) in circuit #2 are active. One of the compressors in circuit #2 will be shut down in order to raise the DAT at the sacrifice of slightly less dehumidification capability.
- Upon termination of dehumidification (reheat), the maximum ramp down or decay rate of the reheat control valves shall be 1% per sec (or 0.1V per sec).
- The reheat valve stepper motor will require occasional re-synchronization to assure the motor and driver remain in step with one another. Every 24 hours, the reheat control valve will automatically be synchronized by driving the valve to its minimum position plus 10% over drive closed. The reheat valve will also be synchronized if there are unexpected system responses in relation to valve position.
- Dehumidification status can be found under the MTIII main system menu along with reheat capacity (valve position) display based on percentage (0-100%).
- A solenoid (SV6) and a check valve is provided to the reheat refrigeration circuit. The solenoid is normally closed and removes refrigerant from the reheat portion of the refrigerant circuit when Reheat is inactive. When Reheat is active, the solenoid closes and isolates the reheat portion of the refrigeration circuit. When the solenoid is in the open position, it meters (by pulsing) refrigerant flow as it enters the suction line. This feature reduces the amount of refrigerant needed for reheat up to 75%, compared to a flooded system arrangement. The bleed solenoid is also pulsed at the start of the circuit to remove any refrigerant that may have leaked past the stepper valve and check valve while the circuit was off.

## MLSCRH+MHGRH Control & Arrangement

- In conjunction with dehumidification, the combination of MLSCRH & MHGRH is used to increase the gross cooling capacity of the unit by increasing the subcooling along with utilizing hot gas reheat to assist in controlling the temperature of air leaving the unit. This combination option is done with two separate reheat coils located downstream of the DX coil in the air handling portion of the unit.
- Operation is similar to MHGRH where compressor staging is based on leaving DX temperature and MLSCRH is modulated to achieve and maintain the DAT setpoint.
- If MLSCRH is at maximum signal and unable to achieve DAT setpoint (minus ½ dead band) then MHGRH is activated to trim the DAT to the setpoint.
- MLSCRH is installed in both circuit #1 and circuit #2.
- The minimum position for the liquid reheat valves is 15%. The controller will modulate the reheat valves from this starting position.
- The maximum reheat signal for the liquid reheat valves is 100%.
- Communication with the liquid valves is accomplished by 0-10Vdc signal from the unit controller with the use of an interface board.
- The liquid subcool reheat valve stepper motor will require occasional re-synchronization to assure the motor and driver remain in step with one another. Every 24 hours, the reheat control valve will automatically be synchronized by driving the valves to their maximum position (10 Vdc) for 60 seconds and then driving the valves to their minimum position (0%) for an additional 60 seconds. The reheat valves will also be synchronized if there are unexpected system responses in relation to the valves position.

**NOTE:** MLSCRH not available for heat pump units.

## Humidification

A unit can be ordered with a factory installed humidification grid/manifold assembly. Figure 162 shows the humidifier section as it comes from the factory. All additional piping, valves, traps, generators (if required), and controls are to be field supplied and installed. It is the responsibility of the installer to ensure that these are safely sized, configured and installed.

Figure 162: DPSA Humidifier

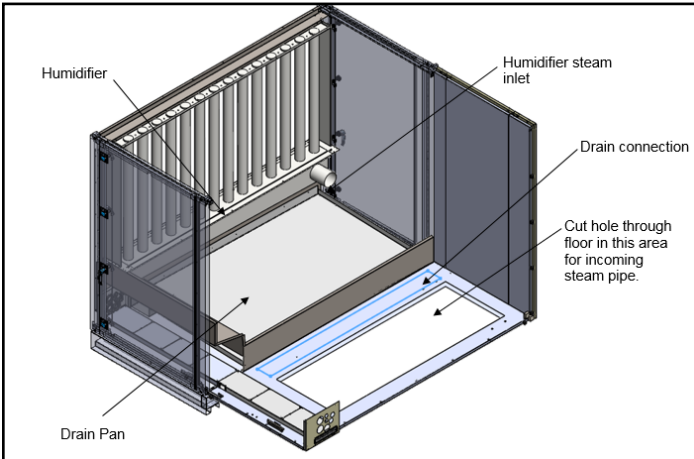


Figure 163: Humidifier Grid Drain Pan Connection

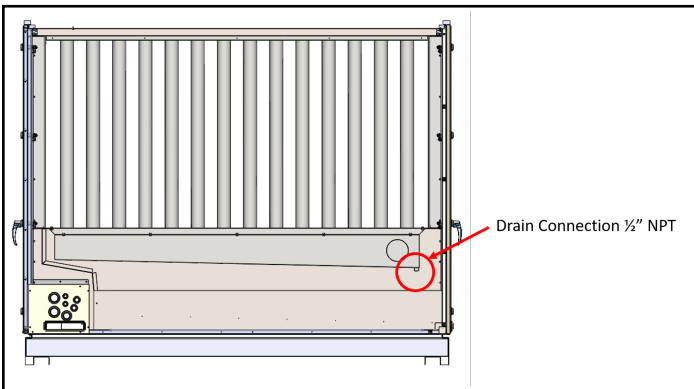
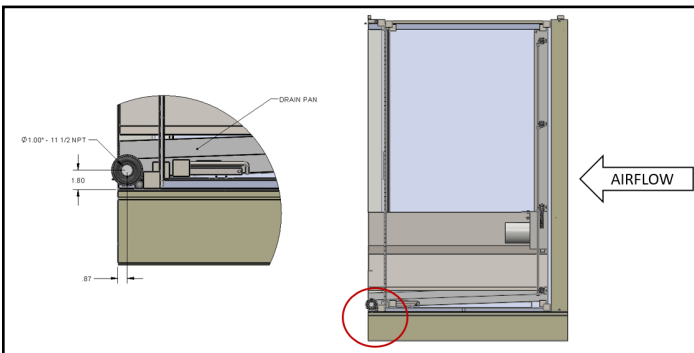


Figure 164: Humidifier Drain Pan Hole Location



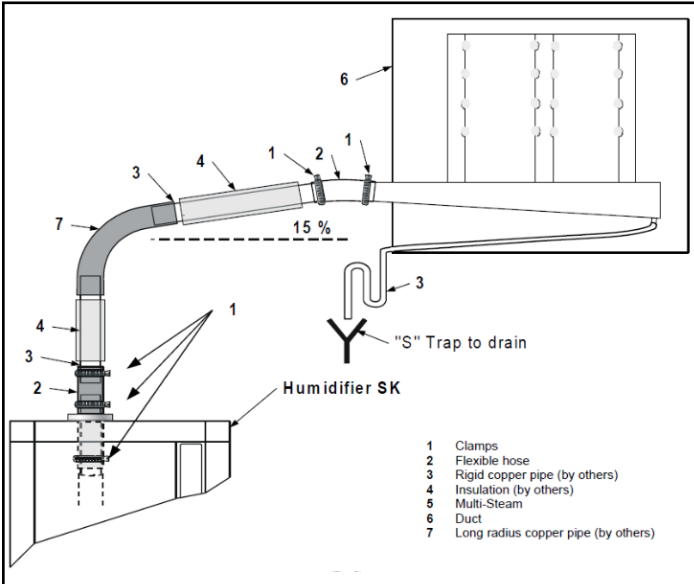
## Steam Supply Line Connection

Table 26: Humidifier Connections Sizes

Number of Tubes	Steam Type	Cabinet	Steam Inlet Size	Drain Outlet Size
4	Atmospheric	B	4 in. OD	1/2 in. NPT
		C	5 in. OD	
6	Pressurized (SKD)	B & C	1-1/4 in. NPT	1/2 in. NPT
		B & C	5 in. OD	
8	Atmospheric	B, C & D	5 in. OD	1/2 in. NPT
		E	2 x 4 in. OD	
10	Pressurized (SKD)	All	1-1/4 in. NPT	1/2 in. NPT
		B, C & D	5 in. OD	
12	Atmospheric	E	2 x 5 in. OD	1/2 in. NPT
		B, C & D	1-1/4 in. NPT	
		E	1-1/2 in. NPT	
14	Pressurized (SKD)	B, C & D	5 in. OD	1/2 in. NPT
		E	2 x 5 in. OD	
		B, C & D	1-1/4 in. NPT	
16	Atmospheric	B & C	5 in. OD	1/2 in. NPT
		D & E	2 x 5 in.	
		B & C	1-1/4 in. NPT	
18	Pressurized (SKD)	D	1-1/2 in. NPT	1/2 in. NPT
		E	2 in. NPT	
		D & E	2 x 5 in.	
20	Atmospheric	D & E	2 in. NPT	1/2 in. NPT
		D & E	2 x 5 in.	
20	Pressurized (SKD)	E	2 in. NPT	1/2 in. NPT
		E	2 x 5 in.	

Figure 165 on page 82 shows proper installation of supply line connections.

**Figure 165: Humidifier Supply Line Installation**



Follow the below general installation rules in order to avoid any condensation accumulation which can cause severe water accumulation in the duct or a humidifier malfunction.

**NOTICE**

Risk of malfunction. Avoid kinks, sags, and areas where condensate can become trapped. Plumbing installation should conform to Local and National Codes.

**Figure 166: Proper and Improper Installation Examples**



1. The slope of the steam hose (rigid or flexible) should not be less than 15% (7 horizontal lengths for 1 vertical length) in order to ensure continuous drainage of condensation back to humidifier or to steam trap.
2. The lowest point of any steam hose or rigid pipe must be the humidifier. If necessary, a steam trap (S Type) should be installed higher than the static pressure of the system by at least 2 in. (51 mm).
3. Total length of the steam hose or rigid pipe should not exceed 15 feet (5 meters). Longer runs will result in added condensation losses. Whenever possible, use insulated copper piping. Flexible steam hose should be used for short runs (up to 15 feet or 5 m) or for interconnecting between the rigid pipe runs. For longer runs, consult the factory.
4. Whenever using rigid copper pipe, use insulation to diminish condensation build up.

**Single steam outlet**

- Run one steam line from the steam outlet of the evaporation chamber of the humidifier to the Multi-Steam header (a reducer is welded at the inlet of the Multi-Steam header).
- Use steam hose and clamps to make the connection from hard insulated copper pipe to the Multi-Steam and the humidifier.

**NOTICE**

Never reduce the diameter of the steam lines. Improper size will over-pressurize the humidifier.

**Condensate drain outlet**

The Multi-Steam has a 1/2 in. (15 mm) or 3/4 in. (20 mm) NPT (or BSPT) condensate drain connection.

**NOTICE**

Remove the 1/2 in (15 mm) or 3/4 in (20 mm) cap (shipping protection) from the condensate drain before the installation.

- Run a pipe (same size as the condensate drain connection) as directly as possible from the condensate drain outlet to the floor drain with a proper slope and install a steam trap to prevent any steam leakage from the drain.
- The steam trap (S Type) should be installed higher than the static pressure of the system by at least 2 in. (51 mm).

**Start-up procedure**

Follow this start-up procedure to avoid improper system operation:

1. Ensure that plumbing connections have been done in accordance with the instructions in this manual.
1. Verify that the steam supply line is connected properly to the Multi-Steam.
2. Verify that the Humidifier Grid is properly pitched.
3. Verify that the Humidifier Grid condensate drain is connected to the drain line.

**Maintenance**

- Inspect the Multi-Steam at start-up and during normal operation.
- Make sure all hose connections are secure and there are no leaks in the line.

**Troubleshooting**

Problem	Causes	Corrective Actions
Multi-Steam discharges water inside the duct or AHU	<ul style="list-style-type: none"> <li>• Steam supply line is not insulated.</li> <li>• Steam supply line is not properly drained or sloped.</li> <li>• The Multi-Steam condensate drain is blocked or drain line is not properly sloped.</li> <li>• The Multi-Steam is not properly pitched.</li> <li>• Steam or condensate is leaking from the gasket on the Multi-Steam collapsible.</li> </ul>	<ul style="list-style-type: none"> <li>• Insulate the steam supply line.</li> <li>• Install steam trap to remove the condensate from the steam supply line.</li> <li>• Slope the steam supply line properly as per instruction.</li> <li>• Verify the condensate drain line.</li> <li>• Pitch the Multi-Steam as per instructions in Fig. <a href="#">Figure 136</a> and <a href="#">Figure 137</a></li> <li>• Replace the gasket (Daikin Applied PN: SP 6867).</li> </ul>

**VAV Box Output**

In the Heating state, the VAV Output is turned OFF to indicate that hot air instead of the normal cool air is being supplied to the VAV boxes. The VAV boxes are driven to their Heating Position when hot air is provided based on either the normally open or normally closed contacts of the VAV output. The VFD will continue to be controlled to maintain the desired duct static pressure. This output is also OFF when the unit is in the Start Up or Recirculation states. If this output is in the Heat (OFF) position when the unit enters the Fan Only state or Minimum DAT Control state, the output remains OFF for an adjustable Post Heat Time (while the unit VFDs are driven to minimum speed) or until the VFD gets to its minimum speed if the Post Heat Time is set greater than 0. The Post Heat Timer can be adjusted via the keypad/display Timer Setting menu in the Extended Menus.

During unoccupied operation, the VAV Box Output is in the Cool (ON) position unless airflow is detected. When airflow is detected, it switches to the Heat (OFF) position.

## Entering Fan Temperature Sensor

The entering fan temperature (EFT) sensor and an associated "Lo Airflow Problem" alarm are provided on VAV units with MicroTech control and gas or electric heat. The EFT sensor is located in the supply fan section of the unit at the supply air funnel.

Heat is disabled whenever the airflow is detected to be too low for safe heating operation. This condition is indicated when the supply air temperature exceeds the mixed air temperature by more than 60°F (16°C).

**NOTE:** This value is not always 60°F (16°C). It depends on whether the unit is gas or electric heat and on the burner/ baffling arrangement on gas heat units.

In this case, a "Lo Airflow Problem" alarm is generated and heat is not enabled until the alarm is manually cleared. Refer to the operation manual for information on clearing alarms ([OM 1373](#)).

## Duct High Pressure Limit

The duct high pressure limit control (DHL) is provided on all VAV units. The DHL protects the duct work, the terminal boxes, and the unit from over pressurization, which could be caused by, for example, tripped fire dampers or control failure. The DHL control is factory set to open when the discharge plenum pressure rises to 5.0" W.C.

If the DHL switch opens, digital input DI5 on the Main Control Board de-energizes. The MicroTech controller then shuts down the unit and enters the Off-Alarm state. The alarm must be manually cleared before the unit can start again.

Refer to the operation manual supplied with your unit for more information on clearing alarms ([OM 1373](#)).

## Variable Frequency Drive Operation

Refer to the vendor instructions supplied with the unit.

## Convenience Receptacle/Section Lights

A Ground Fault Circuit Interrupter (GFCI) convenience receptacle is provided in the main control box. Both unit-powered and field-powered versions are offered.

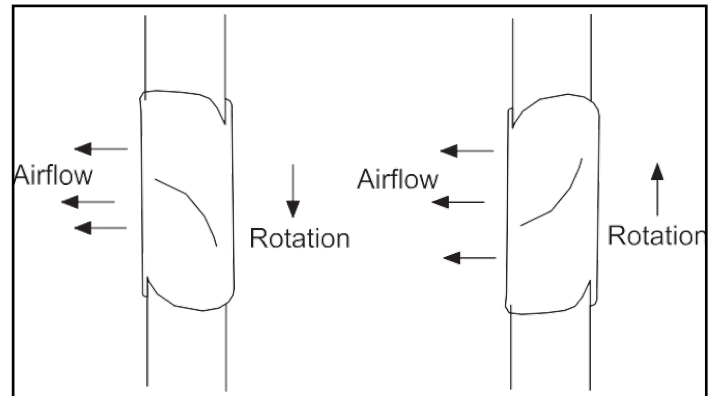
Optional lights are available for certain sections in the unit. Each light includes a switch and convenience receptacle and is powered by the external 115V power supply connected to TB7.

## Propeller Exhaust Fan Option

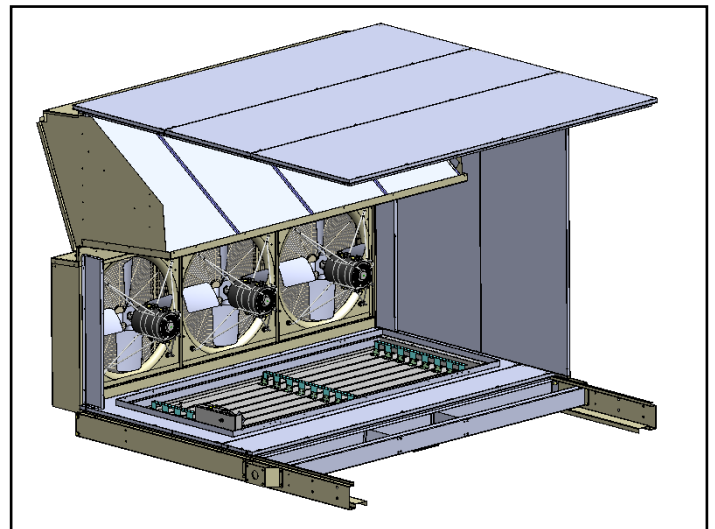
Economizer units may include propeller exhaust or centrifugal return fan options. This section covers maintenance and operating instructions for the propeller exhaust option.

Centrifugal return fan construction, maintenance and operation is similar to supply fans and covered in other sections of this manual.

**Figure 167: Fan Rotation**



**Figure 168: Three Fans with Bottom Return**



## Fan Prestarting Checks

Check all fasteners and set screws for tightness. This is especially important for bearing set screws.

The propeller should rotate freely and not rub on the fan panel venturi. Rotation direction of the propeller should be checked by momentarily turning the unit on. Rotation should be in the same direction as the rotation decal affixed to the unit or as shown in [Figure 167 on page 84](#). For three-phase installations, fan rotation can be reversed by simply interchanging any two of the three electrical leads.

## Fan Maintenance

Once the fan is put into operation, set up a periodic maintenance program to preserve the reliability and performance of the fan. Items to include in this program are:

- Bearings
- Fasteners
- Setscrews
- Lubrication
- Removal of Dust/Dirt

## Damper Counterbalance Adjustment

The following instructions should be followed when attempting to maximize the counterbalance effect on the dampers. Be aware that when the balance setting is highly sensitive, friction wear and contamination will have an adverse effect to the operation of the damper. The sensitivity of the counterbalance should only be set to meet the application requirements. The damper must be mounted square and plumb and operate freely before any weight adjustments are performed.

## Ultraviolet Lights Option

### WARNING

POSSIBLE EXPOSURE TO ULTRAVIOLET RADIATION AND HAZARDOUS VOLTAGE!

Failure to disconnect power before servicing could result in severe electrocution or burns leading to serious injury or death. This product contains components that emit Ultraviolet Light radiation (UV-C) which can be harmful to the skin and unprotected eyes. Disconnect all electrical power, including remote disconnects, and ensure UV lights are off before servicing. Follow proper LOCKOUT/TAGOUT procedures to ensure the power cannot be energized while in service.

**NOTE:** See “[Indoor Air Quality \(IAQ\) Installations](#)” on page 66 for additional details.

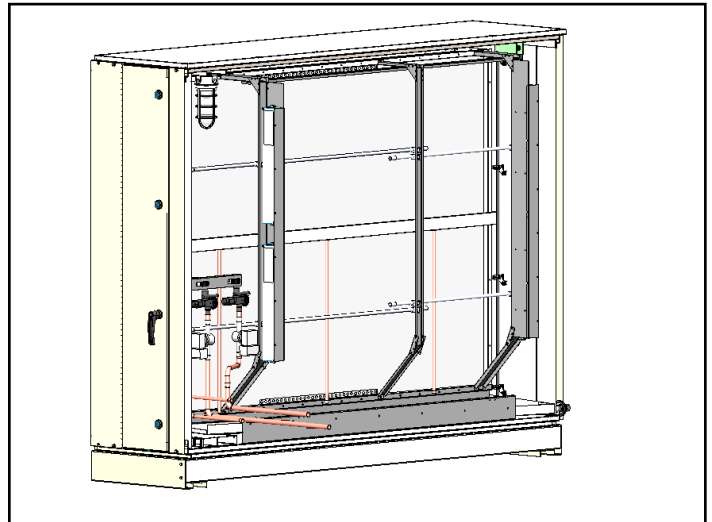
When this option is employed, ultraviolet C light bathes the moist surfaces on the coil and drain pan, killing most microorganisms that can grow there.

Typically, ultraviolet lights are installed on the leaving side of the cooling coils in the unit. Each light module is mounted on a vertical rail and is removable for convenient bulb replacement.

UV Light Power Disconnect switches (one per door) are factory installed on every door that allows a direct line of sight to the UV lamps when opened. These switches are designed to prevent UV exposure when cabinet doors are opened and must not be disabled.

A viewing window near the UV lights allows viewing to determine if the lights are energized. The viewing windows use specially designed glass that blocks harmful UV light.

**Figure 169: Typical Ultraviolet Light Installation**



### Ultraviolet Light Operation

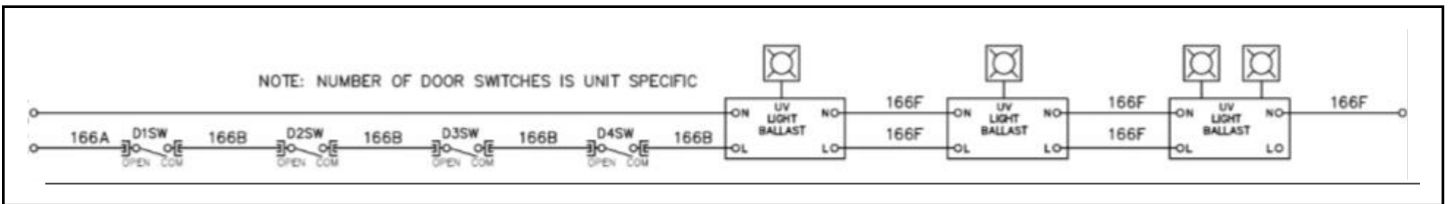
The Ultraviolet (UV) Lights are powered by the main 115V transformer and therefore will normally be on whenever the unit is powered on. There are door switches that are installed on some doors with access to UV radiation. These doors must be closed for the UV lights to operate. If any one of these doors are opened, the UV lights will lose power and turn off. When entering the space where there may be UV light, ensure the UV lights are off by removing power from the unit by turning off the main power disconnect(s). Refer to [Figure 170](#) for UV Light control schematic. Always refer to the Unit Specific Electrical Schematics for information regarding the number of door switches present.

### Convenience Receptacle/Section Lights

A Ground Fault Circuit Interrupter (GFCI) convenience receptacle is provided in the main control box on all units. The receptacle can either be field powered or unit powered. If it is field powered, a field wired 120V circuit must be provided. Refer to the [Field Power Wiring](#) section for more details. If the receptacle is unit powered, then no additional field wired 120V circuit is required for its function.

If the optional service lights were included, the light switch will be located near the GFCI receptacle. The lights are always powered by the same source as the GFCI; either unit powered or Field powered depending on the GFCI option selected.

**Figure 170: Typical Ultraviolet Light Wiring Schematic**



## Start-Up, Checks, and Tests

### DANGER

LOCKOUT/TAGOUT all power sources before servicing this equipment. More than one disconnect may be required to de-energize unit.

Electric shock and moving components such as, fans, dampers, energy recovery devices can cause serious injury, death, and property damage.

All start-up and service work must be performed only by trained, experienced technicians familiar with the hazards of working on this type of equipment.

Read and follow the all relevant manuals before operating or servicing.

Bond the equipment frame to the building electrical ground through grounding terminal or other approved means.

All units complete an end-of-line operation test at the factory to promote proper operation in the field. Nevertheless, the following check, test, and start procedures must be performed to properly start the unit. To obtain full warranty coverage, complete and sign the check, test, and start form supplied with the unit, or complete the “Warranty” on page 193 and return it to Daikin Applied.

A representative of the owner or the operator of the equipment should be present during start-up to receive instructions in the operation, care, and maintenance of the unit.

## Servicing High Voltage Control Panel Components

### DANGER

LOCKOUT/TAGOUT all power sources prior to servicing the unit. Hazardous voltage may cause serious injury, death, and property damage. Disconnect electric power before servicing equipment. More than one disconnect may be required to de-energize the unit.

Disconnect all electric power to the unit when servicing control panel components. Unless power is disconnected to the unit, the components remain energized. Always inspect units for multiple disconnects to ensure all power is removed from the control panel and its components before servicing.

### **Before Start-up**

1. Verify that the unit is completely and properly installed with ductwork connected.
2. Verify sensors have been installed as required, such as DAT, duct, and building static pressure tubing.
3. Verify that all construction debris is removed, and that the filters are clean.
4. Verify that all electrical work is complete and properly terminated.
5. Verify that all electrical connections in the unit control panel and compressor terminal box are tight, and that the proper voltage is connected.
6. Verify all nameplate electrical data is compatible with the power supply.
7. Verify the phase voltage imbalance is no greater than +/- 4%.
8. Manually rotate all fans and verify that they rotate freely.
9. Verify all fasteners on the fan assemblies are still tight.
10. Verify that the evaporator condensate drain trap is installed and that the drain pan is level.
11. If unit is curb mounted, verify that the curb is properly flashed to prevent water leakage.
12. Before attempting to operate the unit, review the control layout description to become familiar with the control locations.
13. Review the equipment and service literature, the sequences of operation, and the wiring diagrams to become familiar with the functions and purposes of the controls and devices.
14. Verify that the crankcase heaters are operating. These should operate for at least 24 hours before starting the compressors.
15. Determine which optional controls are included with the unit.

## Using the Keypad/Display

The keypad/display consists of a 5-line by 22 character display, three keys and a “push and roll” navigation wheel. There is an Alarm Button, Menu (Home) Button, and a Back Button. The wheel is used to navigate between lines on a screen (page) and to increase and decrease changeable values when editing. Pushing the wheel acts as an Enter Button.

The first line on each page includes the page title and the line number to which the cursor is currently “pointing”. The line numbers are X/Y to indicate line number X of a total of Y lines for that page. The left most position of the title line includes an “up” arrow to indicate there are pages “above” the currently displayed items, a “down” arrow to indicate there are pages “below” the currently displayed items or an “up/down” arrow to indicate there are pages “above and below” the currently displayed page.

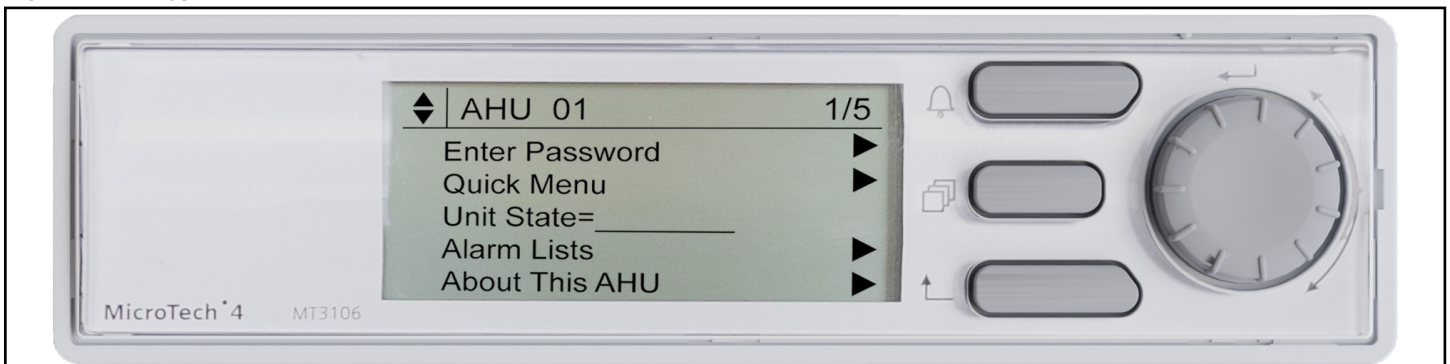
Each line on a page can contain status only information or include changeable data fields. When a line contains status only information and the cursor is on that line all but the value field of that line is highlighted meaning the text is white with a black box around it. When the line contains a changeable value and the cursor is at that line, the entire line is highlighted. Each line on a page may also be defined as a “jump” line, meaning pushing the navigation wheel will cause a “jump” to a new page. An arrow is displayed to the far right of the line to indicate it is a “jump” line and the entire line is highlighted when the cursor is on that line.

The keypad/display Information is organized into five main menus or menu groups; Alarm Lists Menu, System Summary Menu, Standard Menus, Extended Menus and Advanced Menus.

Only menus and items that are applicable to the specific unit configuration are displayed.

The Alarm Lists Menu includes active alarm and alarm log information. The System Summary Menu includes status information indicating the current operating condition of the unit. Standard Menus include basic menus and items required to setup the unit for general operation. These include such things as control mode, occupancy mode and heating and cooling setpoints. Extended Menus include more advanced items for “tuning” unit operation such as PI loop parameters and time delays. Advanced Menus include the most advanced items such as “unit configuration” parameters and service related parameters. These generally do not need changing or accessing unless there is a fundamental change to or a problem with the unit operation.

**Figure 171: Keypad Controls**



### Passwords

When the keypad/display is first accessed, the Home Key is pressed, the Back Key is pressed multiple times, or if the keypad/display has been idle for the Password Timeout timer (default 10 minutes), the display will show a “main” page where the user can enter a password or continue without entering a password.

Various menu functions are accessible or inaccessible, depending on the access level of the user, and the password they enter, if any. There are four access levels, including no password, Level 2, Level 4, and Level 6, with Level 2 having the highest level of access. Without entering a password, the user has access only to basic status menu items. Entering the Level 6 password (5321) allows access to the Alarm Lists Menu, Quick Menu, and the View Status Unit Menus group. Entering the Level 4 password (2526) allows similar access as Level 6 with the addition of the Commission Unit Menu, Manual Control, and Service Menu groups. Entering the Level 2 password (6363) allows similar access as Level 4 with the addition of the Unit Configuration Menu. To access the advanced menu, you need to enter a level 2 password and set the enable advanced menu flag to Yes in the service menu.

Continuing without entering one of these three levels allows access only to the Alarm Lists Menu and the System Summary Menu.

**NOTE:** Alarms can be acknowledged without entering a password.

The password field initially has a value \*\*\*\* where each \* represents an adjustable field. These values can be changed by entering the Edit Mode.

Entering an invalid password has the same effect as continuing without entering a password.

Once a valid password has been entered, the controller allows further changes and access without requiring the user to enter a password until either the password timer expires or a different password is entered. The default value for this password timer is 10 minutes. It is changeable from 3 to 30 minutes via the Timer Settings menu in the Extended Menus.

Figure 172: Password Main Page

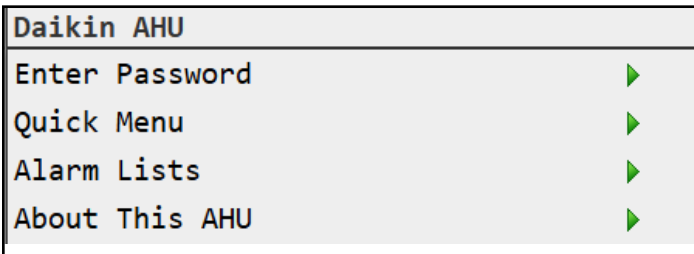
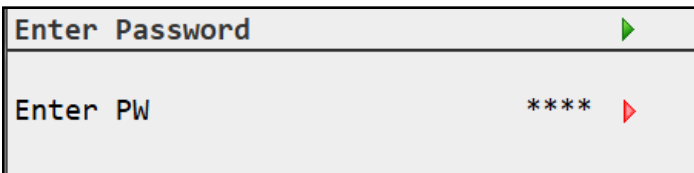


Figure 173: Password Entry Page



### Navigation Mode

In the Navigation Mode, when a line on a page contains no editable fields all but the value field of that line is highlighted meaning the text is white with a black box around it. When the line contains an editable value field the entire line is inverted when the cursor is pointing to that line.

When the navigation wheel is turned clockwise, the cursor moves to the next line (down) on the page. When the wheel is turned counter-clockwise the cursor moves to the previous line (up) on the page. The faster the wheel is turned the faster the cursor moves.

When the Back Button is pressed the display reverts back to the previously displayed page. If the Back button is repeated pressed the display continues to revert one page back along the current navigation path until the “main menu” is reached.

When the Menu (Home) Button is pressed the display reverts to the “main page.”

When the Alarm Button is depressed, the Alarm Lists menu is displayed.

### Edit Mode

The Editing Mode is entered by pressing the navigation wheel while the cursor is pointing to a line containing an editable field. Once in the edit mode pressing the wheel again causes the editable field to be highlighted. Turning the wheel clockwise while the editable field is highlighted causes the value to be increased. Turning the wheel counter-clockwise while the editable field is highlighted causes the value to be decreased.

The faster the wheel is turned the faster the value is increased or decreased. Pressing the wheel again cause the new value to be saved and the keypad/display to leave the edit mode and return to the navigation mode.

**NOTE:** If desired, you can significantly reduce all MicroTech internal control timers by the changing the entry under keypad menu Main Menu\Commission Unit\ Timer Settings\Startup,Recirculate = (from 180s to 60s min where 60s is the number of seconds you want the unit to operate with fast timers).

### Initial Manual Mode Start-Up

Initial Start-up should be performed in manual control mode before proceeding to the cooling/heating start up.

#### Power Up

1. Close the unit disconnect switch. With the control system switch in the OFF position, power should be available only to the control circuit transformer (T1) and the compressor crankcase heaters.
2. Turn the Switch to ON. Power should now be supplied to the control panel, and the LEDs on MCB1 should follow the normal start-up sequence.

## Supply Fan Start-up

1. Verify all duct and unit mounted isolation dampers are open.
2. Place the unit into Manual Control Mode through the keypad menu **Main Menu\Manual Control\Manual Ctrl = Manual**.
3. Activate the Fan through the keypad menu **Main Menu\Manual Control\Supply Fan = On**; Set **SAF Cap Cmd = 40%**.
  - a. Check Fan rotation for proper rotational direction.
4. Speed the fan Up through the keypad menu **Main Menu\Manual Control\SAF Cap Cmd = 100%**.
  - a. Check the manual motor protectors or that the circuit breakers have not tripped.
  - b. Check the phase monitor.
5. Verify the DHL safety, if included, is opening at a pressure compatible with duct working pressure limits.

**NOTE:** Supply and return or exhaust fans should be adjusted for proper airflow during air balancing.

## OA Damper Start-up

1. Check whether the outdoor air is suitable for free cooling by displaying the keypad menu **Main Menu\Manual Control\OA Damper Position=30%**.
  - a. Verify that the OA damper position moved and the Return air damper (if present) also moved.
  - b. Leave OA damper Open for next step.

## Return/Exhaust Fan Start-up

1. Verify all duct and unit mounted isolation dampers are open.
2. Activate the Fan through the keypad menu **Main Menu\Manual Control\Ret/Exh Fan = On**; Set **Ret/Exh Fan Cmd = 40%**.
  - a. Check Fan rotation for proper rotational direction.
3. Speed the fan Up through the keypad menu **Main Menu\Manual Control\Set Ret/Exh Fan Cap Cmd = 100%**.
  - a. Check the manual motor protectors or that the circuit breakers have not tripped.
  - b. Check the phase monitor.
4. Verify the DHL safety, if included, is opening at a pressure compatible with duct working pressure limits.

**NOTE:** Supply and return or exhaust fans should be adjusted for proper airflow during air balancing.

**Leaving Manual Control when complete** through the keypad menu **Main Menu\Manual Control\Manual Ctrl = Normal**.

## Cooling/Heating Start up

### Supply Fan Start-up

1. Verify all duct and unit mounted isolation dampers are open.
2. Place the unit into Fan Only through the keypad menu. **Main Menu\Quick Menu\Ctrl Mode= FanOnly**.
  - a. The fan will activate.
  - b. Check the manual motor protectors or that the circuit breakers have not tripped.
  - c. Check the phase monitor.
3. Verify the DHL safety, if included, is opening at a pressure compatible with duct working pressure limits.

**NOTE:** Supply and return or exhaust fans should be adjusted for proper airflow during air balancing.

### Economizer/OA Damper Start-up

1. Check whether the outdoor air is suitable for free cooling by displaying the keypad menu **Main Menu\ViewStatus\Economizer\FreeClgStatus=Avai** or **Unavail** verify that the enthalpy changeover control is working properly. You may want to take temperature and humidity measurements.
2. At the keypad, set the cooling setpoint low enough so that the controller will call for cooling. Adjust the value in **Commission Unit\CoolingSet-Up\Occ Clg Spt** below the temperature shown as Control Temp in the same menu. In addition, on DAC units, adjust the value in **Commission Unit\CoolingSet-Up\DAT Clg Spt** below the temperature shown in Disch Air in the same menu.
3. Place the unit into cooling mode through the keypad menu **Quick Menu\Ctrl Mode = Cool Only**.
4. Observe the outdoor air dampers:
  - a. If the outdoor enthalpy is low, the control algorithm should start to modulate the dampers open to maintain the discharge air setpoint.
  - b. If the outdoor enthalpy is high, the dampers should maintain their minimum position. Look at menu **ViewStatus\Economizer\Min OA Pos**. Change this entry to another value. Verify that the dampers move to the new minimum position setpoint.
5. If the unit is equipped with comparative enthalpy sensors, no adjustment is necessary. MicroTech compares the energy required to cool and dehumidify the outside air vs the return air and decides which is less.

**NOTE:** It may not be possible to check the economizer operation in both low and high enthalpy states on the same day. If this is the case, repeat this procedure on another day when the opposite outdoor air enthalpy conditions exist.

## Fixed Speed Compressor Start-up

### CAUTION

Low ambient temperature can cause compressor damage. Do not attempt to start up and check the refrigeration system when the outdoor air temperature is below 50°F (10°C) unless the unit is specially equipped for low ambient operation.

### NOTICE

Venting refrigerant to atmosphere is not allowed per federal and state laws and local regulations and codes.

Make certain the supply and return fans are operational and prepare for compressor operation.

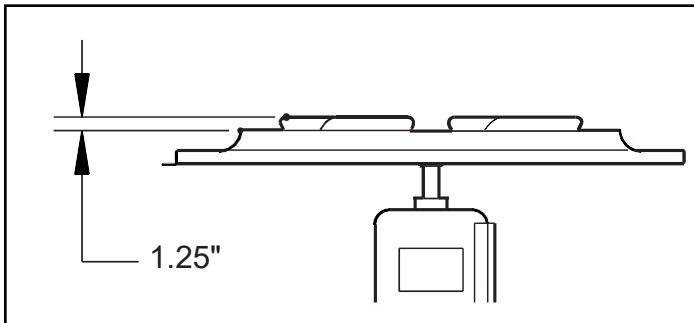
If the unit contains optional compressor isolation valves, Verify that valves are open. These are ball valves that can be opened with a quarter turn.

Verify that the unit has not lost its refrigerant charge. Check the compressor oil level before start-up. The oil level should be at or slightly above the center of the sight glass.

Verify that the crankcase heaters are energized. These should operate for at least 24 hours before starting the compressors.

Verify that the condenser fan blades are positioned properly and that the screws are tight (Figure 174). The fan blade must be correctly positioned within its orifice for proper airflow across the condenser coils.

Figure 174: Condenser Fan Blade Positioning



## Scroll Compressor Rotational Direction

Scroll compressors only compress in one rotational direction. Three-phase compressors can rotate in either direction depending upon phasing of the power to L1, L2, and L3.

Use a phase rotation meter to confirm phasing is clockwise. If the compressor is rotating properly when energized, the suction pressure will decrease and the discharge pressure will increase. If the compressor is rotating in reverse, the sound level is louder and current draw is reduced substantially. After several minutes of operation rotating in the incorrect direction, the compressor's motor protector may trip. Tripping will not damage the compressor as long as it does not continue to repeat this cycle.

All three-phase compressors are wired the same internally. Therefore, once the correct phasing is determined for a specific system or installation, connecting properly phased power leads to the same terminals should maintain proper rotational direction.

### Perform the following procedure on all units:

1. At the keypad, The cooling set point value in **Commission Unit\Cooling Set-Up\Occ Clg Spt** will need to be adjusted below the Control Temp shown in the same menu. In addition, on DAC units, adjust the value in **Commission Unit\Cooling Set-Up\DAT Clg Spt** below the temperature shown in Disch Air in the same menu.
2. Place the unit into cooling mode through the keypad menu **Quick Menu\Ctrl Mode = Cool Only**.
3. Verify that the low ambient compressor lockout temperature setpoint, **Main Menu\Commission Unit\Cooling Setup\Clg Lo OAT Lk** is set below the current outside air temperature (OA Temp) is shown in the same menu.

**NOTE:** Do not attempt to operate the compressors if the outdoor air is below 50°F (10°C). See the caution statement under "Fixed Speed Compressor Start-up".

4. Note that if the unit has an economizer and the outdoor air enthalpy is low, the economizer must fully open before the controller will energize mechanical cooling.
5. When the outdoor air damper has fully opened and the time delay has expired, the liquid line solenoid and the compressor should start.
  - a. Verify that there is a call for cooling by checking the keypad menu **Quick Menu\Unit State =**. This should be in Cooling.
  - b. Check the keypad to ensure the compressors have been enabled. **Main Menu\View Status\Unit Status/Settings\Clg Status =**. The compressors will only run if this reads (Enabled).
6. Verify that compressor #1 starts. If the compressor motor hums but does not run, verify that it is getting three-phase power.

7. The compressor should operate continuously while there is a call for cooling. If the compressor cycles on its low pressure switch, due the following:
  - a. Verify that the circuit is not low on refrigerant.
  - b. Check for low supply airflow.
  - c. Check for clogged filters.
  - d. Check for restricted ductwork.
  - e. Check for very low temperature return air entering the unit.
  - f. Verify that the liquid line components, expansion valve, and distributor tubes are feeding the evaporator coil.
  - g. Verify that all air handling section panels are closed.
  - h. Verify that the liquid line solenoid valves are completely open (energized).
8. If the refrigeration circuit has multiple compressors, verify that the compressors stage properly. As the circuit load increases the second compressor (if available) will be energized.
9. Verify that the condenser fans are cycling (ON/OFF) and rotating properly (blowing air upward). When a compressor starts, at least one condenser fan should also start. MT4 should control the remaining condenser fans based on ambient air conditions. Refer to the unit wiring diagrams for control wiring.
10. After 15 minutes of run time, check the oil level in the compressor sightglass (if available). If low oil or heavy foaming is observed, it is possible that liquid refrigerant is returning to the compressor. Check the suction superheat it should be between 10°F (5.6°C) and 14°F (7.8°C).
11. Place the unit into the “Fan Only” mode through the keypad menu **Main Menu\Quick Menu\Ctrl Mode = fan only**.
12. Check refrigerant circuit #2 by repeating steps 2 through 9.
13. Check the compressor oil level again. If oil level is low, consult Technical Support before adding oil.
14. Verify that the condenser refrigerant subcooling for each refrigeration circuit at full capacity is between as shown in [Table 27](#).

**Table 27: Expected Subcooling for Compressor Start-up (Cooling Only Models)**

Outdoor Air Temp. (°F)	Subcooling (°F)
75-80	7-10
81-90	10-12
91-95	12-15
95-105	15-20

**Table 28: Expected Subcooling for Compressor Start-up (Air-Source Heat Pump Models)**

Outdoor Air Temp. (°F)*	Subcooling (°F)
-5-15	21-23
16-45	23-25
46-61	25-28
62-80	6-8
81-90	8-10
91-95	10-12
96-105	12-15

\*When OAT is below 62°F, it is recommended to charge the unit in heating mode.

## Expansion Valve Superheat Adjustment

### Electronic Expansion Valve

The electronic expansion valve (EEV) superheat setting is preset from the factory and does not require any field adjustment.

### Bypass Loop on Heat Pumps

On units equipped with heat pumps, there will be an outdoor and indoor EEV present.

*In heating mode*, the outdoor electronic expansion valve controls refrigerant flow and the indoor EEV is 100% open.

*In cooling mode*, the indoor EEV controls refrigerant flow. The outdoor EEV is 100% open and refrigerant will also flow through the one-way bypass to prevent pressure drop.

### Checking Superheat

Following are recommendations for checking superheat:

1. Close the unit section doors. Operating the unit with its doors open will affect the expansion valve and system operation considerably.
2. For units with one expansion valve per circuit, check the pressure and temperature at the compressor suction valve.

**NOTE:** If low oil level is accompanied by heavy foaming visible in the oil sight glass, it is possible that excess liquid refrigerant is returning to the compressor. Check the suction superheat and adjust the expansion valve for 10°F (5.6°C) and 14°F (7.8°C) of superheat. If proper superheat is obtained, sight glass foaming is not a concern.

## Heating System Start-up

### General

1. At the keypad, set the heating setpoints high enough so that the controller calls for heating. Adjust the value in **Main Menu\Commission Unit\Heating Set-Up\Occ Htg Spt** = above the Control Temp shown in the same menu. In addition, on DAC units, adjust the DAT heating value in **Main Menu\Commission Unit\Heating Set-Up\ DAT Htg Spt** above the discharge temperature shown as Disch Temp in the same menu.
2. Place the unit into heating mode through the keypad menu **Main Menu\quick Menu\Ctrl Mode = Heat Only**.
3. Verify that the high ambient heat lockout temperature setpoint, **Main Menu\Commission Unit\Heating Setup\ Htg Hi OAT Lk** is set above the current outside air temperature (OA Temp) is shown in the same menu.

### Hot Water and Steam Heat

The Hot Water or Steam valve actuator should open the valve. The hot water or steam valve is open when the valve stem is up. If the unit loses power, the spring in the actuator should drive the valve wide open.

## Refrigerant Charging and/or Evacuation

When evacuating and charging refrigerant, ensure all necessary valves are open to prevent trapping refrigerant in the system. This can be done manually by navigating to **Main Menu\Cmp Circ Man Ctrl**. Some units are equipped with an **Evac/ChrgMode** menu selection, which will automatically set states for evacuation and/or charging.

### Evac/ChrgMode

If the unit controller is equipped with **Evac/ChrgMode**, the unit must be in the OFF state to activate.

Initiating **Evac/ChrgMode** will set the unit to the following states:

- Compressors are locked out from operation.
- Unit controller commands the following components to the stated positions:

Component	Description	State
LSCRht Valve	(Liquid Sub-Cool Reheat) (stepper motor)	50% Open
MHGRht Valve	(Mod Hot-Gas Reheat) (stepper motor)	50% Open
EHGBP1 Cap, EHGBP2 Cap	-	100% Open
CondSol1 C1, CondSol2 C1	(C1 (Condenser Splitter) solenoid valve(s))	Open
CondSol1 C2, CondSol2 C2	(C2 (Condenser Splitter) solenoid valve(s))	Open
CondSol1 C3, CondSol2 C3	(C3 (Condenser Splitter) solenoid valve(s))	Open
C1 EVI1Cap, C1 EVI2 Cap	(Electronic Expansion Valves, Indoor) (stepper motor)	100% Open
C2 EVI1Cap, C3 EVI2 Cap	(Electronic Expansion Valves, Indoor) (stepper motor)	100% Open
C3 EVI1Cap, C3 EVI2 Cap	(Electronic Expansion Valves, Indoor) (stepper motor)	100% Open
C1 EVO Cap	(Electronic Expansion Valves, Outdoor) (stepper motor)	100% Open
C2 EVO Cap	(Electronic Expansion Valves, Outdoor) (stepper motor)	100% Open
C3 EVO Cap	(Electronic Expansion Valves, Outdoor) (stepper motor)	100% Open
4WV1, 2, 3	(4-way valve)	Off; Leave in normal (cooling) state
CCH1, 2, 3	(Variable Compressor Crank Case Heaters)	ON
RH Bleed Valve	-	Open

**NOTE:** The unit will only display the menu items it is configured for.

Leaving the unit in **Evac/ChrgMode** sets the unit to the following states:

- Valves and crank case heaters are returned to their normal states.
- There will be a delay before allowing compressors to be turned on. This allows valves to return to their normal state.

## Evacuating Refrigerant Charge

1. Navigate to **Main Menu\Cmp Circ Man Ctrl** and place unit into **Evac/ChrgMode**.
2. If **Evac/ChrgMode** is not available on the unit controller, manually set all components to the states defined in “[Evac/ChrgMode](#)” on page 93.
3. Reclaim Refrigerant.

## Charging the System with Refrigerant

1. Navigate to **Main Menu\Cmp Circ Man Ctrl** and place unit into **Evac/ChrgMode**.
2. If **Evac/ChrgMode** is not available on the unit controller, manually set all components to the states defined in “[Evac/ChrgMode](#)” on page 93.
3. Charge unit to value listed on the unit data plate.
4. To optimize performance, charge must be trimmed to values as defined in “[Expected Subcooling for Compressor Start-up \(Cooling Only Models\)](#)” on page 92.

### WARNING

Never charge the unit with a refrigerant type other than what is listed on the data plate. Charging with an unauthorized refrigerant type could lead to property damage, serious personal injury, or death.

### WARNING

Never perform maintenance to the refrigeration system unless refrigerant charge has been completely evacuated, as property damage, serious personal injury, or death may occur. Refer to the charging procedures described in “[Refrigerant Charge](#)” on page 77 or “[R-32 Guidelines](#)” on page 103 for guidance.

## Air Balancing

### DANGER

Moving Machinery hazard. Moving components such as, fans, dampers, energy recovery devices can cause serious injury or death. Do not use a mechanically driven tachometer to measure the speed of return fans on this fan arrangement. Use a strobe tachometer.

### WARNING

Rotating parts can cause serious injury or death. Replace all fan guards that are temporarily removed for service.

Air balancing should be performed by a qualified air balancing technician.

The following should be performed as part of the air balancing procedure:

1. Check the operating balance with the economizer dampers positioned for both full outdoor air and minimum outdoor air.
2. Verify that the total airflow will never be less than that required for operation of the electric heaters.
3. For VAV units that have fan tracking control, adjust the supply/return fan balance by using the MicroTech controller’s built-in, automatic capability.

When all start-up procedures are completed, set the controls and program the MicroTech controller for normal operation. Use the following list as a guide; some items may not apply to your unit.

1. Set the heating and cooling parameters as required for normal unit operation.
  - a. **Main Menu\Commission Unit\HtgClgChgovr Set-Up\Ctrl Temp Scr = RAT, Space, OAT, None** based on application needs. Refer to the unit controller manual for recommendations.
  - b. **Main Menu\Commission Unit\CoolingSet-Up\Occ Clg Spt & DAT Clg Spt.**
  - c. **Main Menu\Commissioning Unit\Heating Set-Up\Occ Htg Spt & DAT Htg Spt.**
2. Set the low ambient compressor lockout setpoint as required in menu, **Main Menu\Commission Unit\Cooling Setup\Clg Lo Oat Lk =**. Do not set it below 50°F (10°C) unless the unit is equipped for low ambient operation.
3. Set the high ambient heat lockout temperature setpoint, **Main Menu\Commission Unit\Heating Setup\Htg Hi OAT Lk** as required.
4. Set the alarm limits as required in **Main Menu\Commission Unit\Alarm Configurations\Alarm Limits**.
5. Set the compressor lead/lag function as desired using keypad menu **Main Menu\Advanced Menus\Cooling Setup\Lead Circuit** and **Main Menu\Advanced Menus\Cooling Setup\Load Method = Lead Load or Cross Load**.

 **CAUTION**

If the unit has hot gas bypass on circuit #1 only, lead circuit must always be circuit #1 and Load method set to Lead Load.

6. Set the duct static pressure control parameters as required in keypad menu **Main Menu\Quick Menu\SAF DSP Spt = \_\_\_ in.; RAF DSP Spt=\_\_\_ in.; BldgSP Spt=\_\_\_ in.** based on application and unit configuration.
7. Set the RF/EF Control Parameters based on the application.
  - a. If RF/EF Control = Tracking, then set the fan tracking parameters as required in keypad menu. **Main Menu\Commission Unit\RF/EF Setup\ Sup Fan Max, RF @ SF Max, Sup Fan Min, RF @ SF Min.**
  - b. If **Main Menu\ Commission Unit\RF/EF Setup\ RF/EF Ctrl = BSP**, Set the building static pressure control parameters as required in keypad menu location **Main Menu\Quick Menu\BldgSP Spt=\_\_\_ in.** based application and unit configuration.
  - c. If **Main Menu\ Commission Unit\RF/EF Setup RF/EF Ctrl = DSP**, Set the building static pressure control parameters as required in keypad menu **Main Menu\ Commission Unit\RF/EF Setup \RAF DSP Spt=.** Based application and unit configuration.
- NOTE:** This configuration is only available with a modulating exhaust air damper.
  - d. **Main Menu\ Commission Unit\RF/EF Setup\ RF/EF Ctrl = OAD**, then set the fan tracking parameters as required in keypad menu. **Main Menu\ Commission Unit\RF/EF Setup\ ExhOn OA Pos=%, ExhMax OAPos =%.**
  - e. For details on commissioning RFEF Ctrl = CAV, Flow, Sped/Net, or Flow Diff, refer to the unit controller manual.
8. Set the outside air damper and economizer control parameters as required in keypad menu **Main Menu\ Commission Unit\OA Damper Set-Up.**
  - a. Set the Vent Limit = % open required at 100% SAF full ventilation.
  - b. Set the loFlo Vent Limit OAD % at minimum SAF speed, full ventilation.
  - c. If the unit is performance DCV (Demand Control Ventilation), Set the DCV limit for the minimum OAD position during DCV at 100% SAF Flow. Set CO2 Reset = PPM@DCVLmt = lower threshold of CO2 ppm allowed and PPM@VentLmt = Upper threshold of CO2 ppm allowed.

9. Set the control timers as required in keypad menu **Main Menu\Commission Unit\Timer Settings.**
  - a. Set the date and time in keypad menu **Setup/ Service\ Time/Date\.**
  - b. Set the operating schedule as required using keypad menus. **Main Menu\ViewStatus\Date/ Time and Date/ Time/Schedules.**

**NOTE:** When used with a Building Automation System, these settings may need to be kept at the default of no schedule.

## Maintaining Control Parameter Records

Daikin Applied recommends that the MicroTech controller's setpoints and parameters be recorded and saved for future reference. If the Microprocessor Control Board (MCB) requires replacement, this record facilitates entering the unit's proper data. The following tables display all the setpoints, monitoring points, and program variables offered by MicroTech plus the keypad road map used to find each parameter.

A number of menus and menu items that appear on the unit keypad/display are conditional and may not apply to a specific unit, depending on the unit software configuration. The unit software configuration is defined by a "Software Configuration Code" shown on a label located near the keypad/display. The Software Configuration Code also can be displayed via the six menu items in the Config Code menu on the unit keypad/ display.

**NOTE:** Keep a record of any changes made to any of these items.

## ECM Motor

ECM motor speed is controlled by the unit mounted MicroTech unit controller, static pressure, and temperature controls to reliably maintain comfort conditions.

These ECM motors include locked rotor, phase failure, low voltage, high temperature and short circuit protection as well as built in soft start logic.

The design speed is programmed into the ECM motor based on desired CFM and ESP. Design speed can be changed as follows as long as the fan's maximum RPM is not exceeded per Table 29.

- Go into the MicroTech unit controller keypad / display
- On the main menu, go to commission unit
- Go to SF [or RF/EF] set up menu
- Find Max SAF [or EAF] RPM
- Enter the desired maximum RPM

**Table 29: ECM Motor Fan Sizes and Maximum Performance**

Fan Diameter (mm)							
31 (310)		35 (355)		45 (450)		56 (560)	
HP	RPM	HP	RPM	HP	RPM	HP	RPM
0.5	2000	-	-	-	-	2.3	1200
1.2	2600	1.7	2400	2.4	1825	5	1590
2.1	3200	3	2870	4.3	2205	6.1	1760
3.1	3750	4.4	3300	7	2600	-	-

## Addressing ECM Motors Procedure

### ⚠ CAUTION

Follow all Lock-Out Tag-Out procedures to minimize risks of personal injury to yourself and/or damage to equipment during this procedure. Always wear appropriate levels of PPE governed by the hazards which are present. Terminals may vary always check unit specific wiring diagrams.

Use this procedure to address EMC motors. ECM – Electronically Commutated Motor communicates via Modbus RS485 twisted pair cables to the MicroTech unit controller. MicroTech can address the ECM for a supply, return-exhaust fan, outdoor fan or energy recovery wheel operation based on a unique Modbus address. A replacement ECM is shipped out from the warehouse with an address of “1” which is a direct replacement for a supply fan and does not require additional setup. If the ECM is used as a return-exhaust fan, outdoor fan or energy recovery wheel, it will need to be set up with one of the following address:

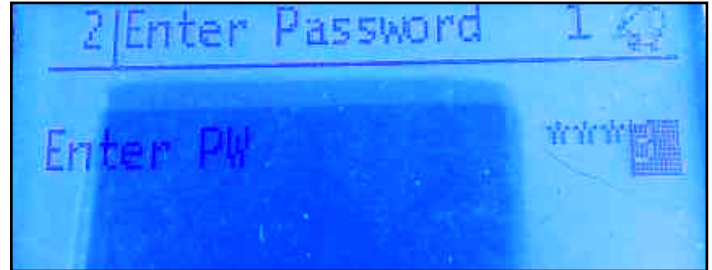
- 2 for RF/EF - return/exhaust fan
- 3 for ER - energy recovery motor
- 4 for OA fan - first outdoor/condenser fan motor
- 5 for OA fan - second outdoor/condenser fan motor

## Addressing ECM Motors

1. Enter password 6363 and turn “Control Mode” to “OFF”.

**NOTE:** Wait for unit to shut down before moving to Step 2.

**Figure 175: “Enter PW”**



2. Shut off power to the unit and follow all Lock-Out-Tag-Out procedures.
3. Using factory provided MMPs/circuit breakers/fuses, remove power supply potential to all motors on the Modbus/RS485 trunk.
4. Verify unit wiring of Modbus/RS485 matches the unit schematic. See Figure 184 on page 98 for an example.
5. Make sure the Modbus/RS485 drains are twisted together and only landed at the controller (not at the motor).

**NOTE:** Ensure no drain is touching bare metal.

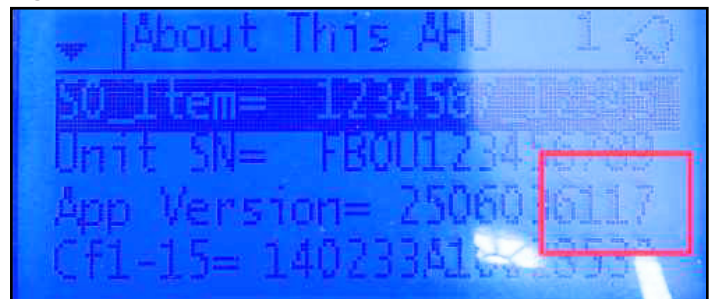
6. Restore power to the unit and to the motor to be addressed only.

**NOTE:** Ensure all motors not being addressed have power interrupted via their respective MMP/circuit breaker/fuses.

7. At the unit controller, enter password (6363) and select “About This AHU”. Ensure the last 4 digits in the app version are 6117 or greater.

**NOTE:** If software is prior to 6117, a software update is required.

**Figure 176: Software Status**



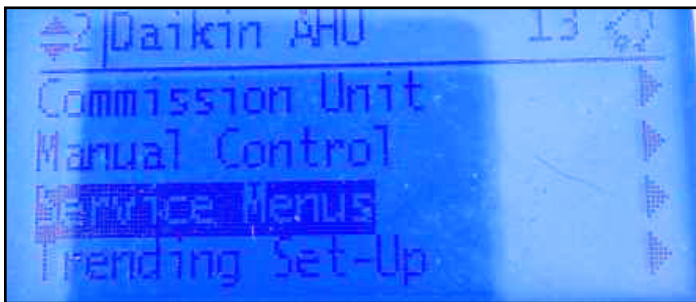
8. Press the middle rectangular button to go back to the main menu.

Figure 177: Button Navigation



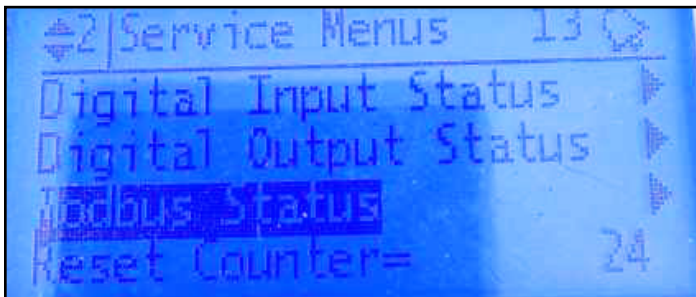
9. Navigate to and select "Service Menu".

Figure 178: Service Menu



10. Navigate to and select "Modbus Status".

Figure 179: Modbus Status

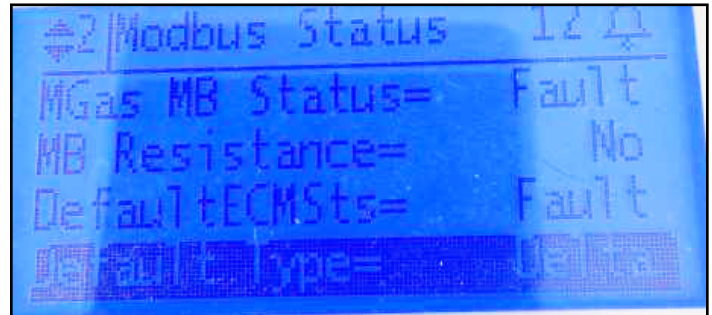


11. Confirm "DefaultECMSts" = OK

**NOTE:** If "DefaultECMSts" = Fault, check Modbus/RS485 wiring and ensure high voltage potential is present to the motor being addressed.

**NOTE:** Replacement motors are shipped with a default address.

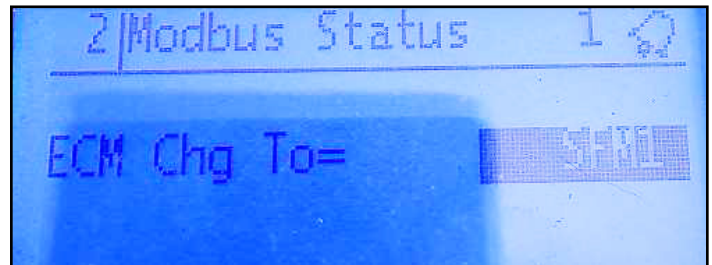
Figure 180: Default Type



12. Navigate to and select the proper address for the value "ECM Chg To" for the motor being addressed.

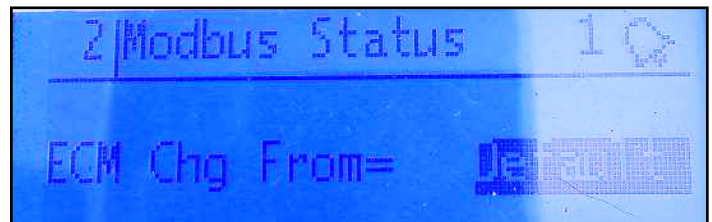
**NOTE:** Example: Default, SAFM1, SAFM2, SAFM3, SAFM4, RFEFM1, RFEFM2, RFEFM3, RFEFM4.

Figure 181: ECM Chg To



13. Navigate to and select "ECM Chg From". Confirm it is set to "Default".

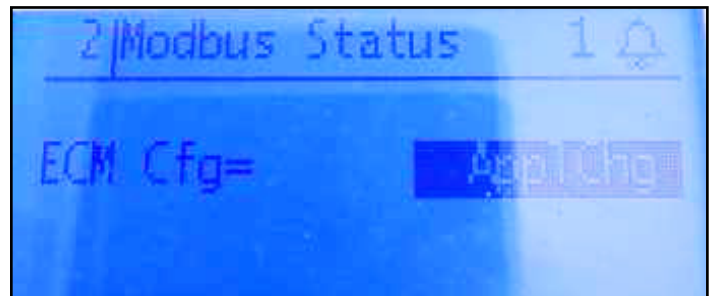
Figure 182: ECM Chg From



14. Navigate to and select "ECM CFG" and select "AppChg". The selection will revert to "Done" if addressing is completed.

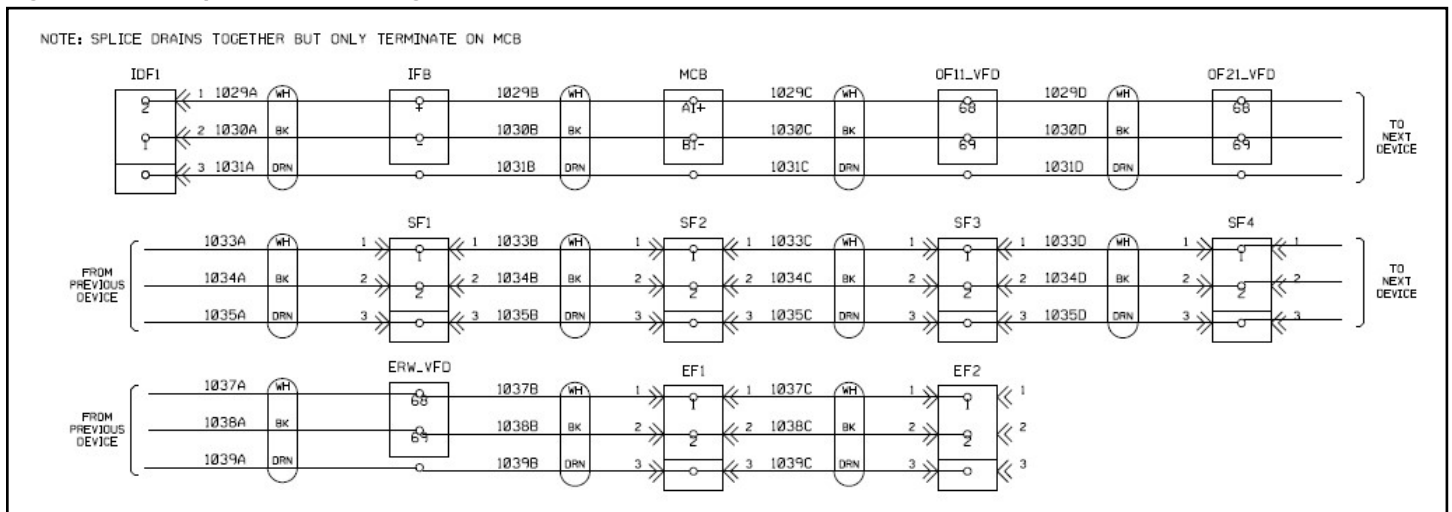
- a. Repeat all steps to this point for any other motors that need to be addressed.

Figure 183: ECM Cfg



15. Turn off power to the unit.
16. Using factory provided MMP/circuit breaker/fuses, restore power supply potential to all motors on the Modbus/RS485 trunk.
17. Restore power to the unit.
18. Enter password 6363. Navigate to and select "Service Menu".
19. Navigate to and select "Modbus Status" and confirm the motor that was addressed reads "OK". Example: "SAF1 MB Status" = OK.

**Figure 184: Example Schematic Diagram**



## Smoke and Fire Protection

**DANGER**

The potential risk of smoke, fire, or fumes entering the unit can result in serious injury, death, and property damage.

Daikin Applied optionally offers factory installed outdoor air, return air, and exhaust air dampers as well as smoke detectors in the supply and return air openings, complete with wiring and control. These components often are used in the building's smoke, fume, and fire protection systems. However, due to the wide variation in building design and ambient operating conditions into which our units are applied, we do not represent or warrant that our products will be fit and sufficient for smoke, fume, and fire control purposes. The owner and a fully qualified building designer are responsible for meeting all local and NFPA building code requirements with respect to smoke, fume, and fire control.

### Smoke Detectors

Field installed smoke detectors in the return air ductwork or the supply air ductwork can be coordinated with the unit's operation through the unit controller's binary input. This input is wired to TB2 and the supply air smoke detector can be wired between terminals 203 and 204 and the return air smoke detector can be wired between terminals 204 and 205. The T2 transformer supplies 24VAC across each of these terminals and a dry set of contacts can be wired to these terminals respectively.

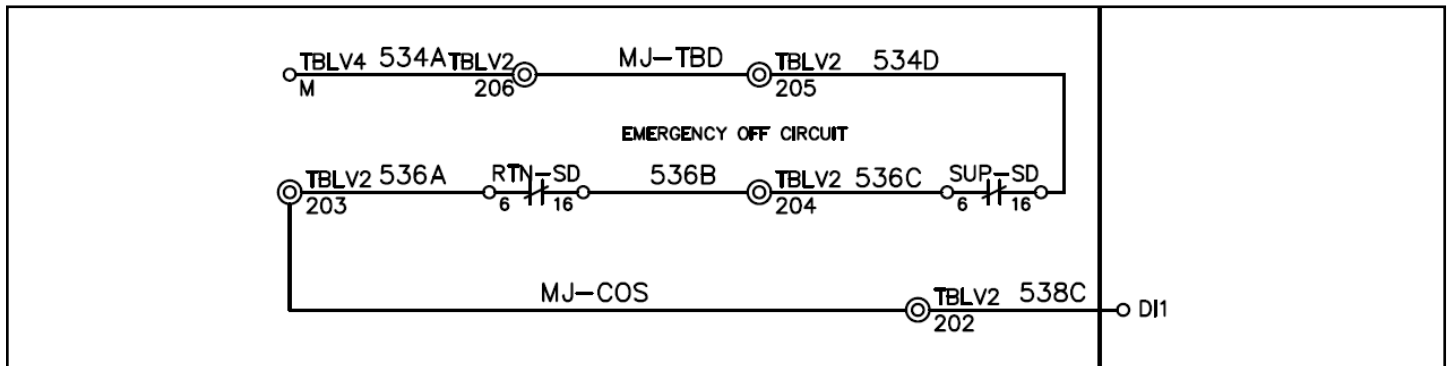
Factory installed smoke detectors have similar wiring and the control sequence is as follows:

When smoke is detected by either sensor, the normally closed sensor contacts open. This removes power from binary input on the main control board.

The MicroTech controller responds by shutting down the unit. The controller is placed in the Alarm Off state and cannot be restarted until the alarm is manually cleared. Refer to the operation manual supplied with the unit for information on clearing alarms.

The smoke detectors must be reset manually once they have been tripped. Power must be cycled to the smoke detector to reset.

Figure 185: Smoke Detector Schematic



### Ventilation Override Control

An Optional ventilation override control feature provides three contact inputs pre-wired in the unit control panel for override control in the event of an emergency. They are all designated on a field wired terminal strip in the low voltage control panel.

**Sequences** - the ventilation control feature allows for one of the following sequences to be performed.

**NOTE:** For all Sequences the Emergency OFF contact should be open.

1. **Ventilate:** When the digital input for Ventilate is active, the Outdoor air damper is opened to 100%.
2. **Pressurization:** When Pressurization is active, the Outdoor air damper is opened to 100%, and the Supply Fan Ramps to Vent Capacity. SAF Vent Capacity is adjustable in the MicroTech under **Main Menu\Advanced Menus\SAF Set-Up\SAFVentCap**.
3. **Purge:** When Purge is active, the return damper is held shut and the Exhaust fan ramps to Vent Capacity. RFEF Vent Capacity is adjustable in the MicroTech under **Main Menu\Advanced Menus\RFEF Set-Up\RFEFVentCap**.

### Emergency Shutdown

The terminals 205 & 206 on TB2 can be used for any field supplied component that requires a unit emergency shutdown. When these terminals are used, the factory installed jumper must be removed.

### Freeze Protection

An optional freezestat is available on units with MicroTech control that have hot water, chilled water, or steam heating coils. The sensing element is located on the downstream side of the heating coil in the heating section of the unit. If the freezestat detects a freezing condition and closes, the MicroTech controller takes different actions, depending on whether the fans are ON or OFF. The freezestat is an auto reset type of control; however, the controller alarm that it causes is manually reset if the fan is on and auto reset if the fan is OFF.

## MicroTech® Remote User Interface

In addition to the unit-mounted user interface provided with MicroTech controls, Daikin Applied rooftop systems can be equipped with a remote user interface that handles up to eight units per interface. The remote user interface provides convenient access to unit diagnostics and control adjustments, without having to access your roof or mechanical rooms located on each floor.

Each remote user interface offers the same functionality as its unit-mounted counterpart, including:

- Push-and-roll navigation wheel with an 8-line by 30 character display format.
- Digital display of messages in English language.
- All operating conditions, system alarms, control parameters and schedules are monitored.

### Features

- Can be wired up to 700 meters from units for flexibility in placing each remote user interface within your building.
- Unit and remote user interfaces are both active.

### MicroTech Field Installed Sensors

The MicroTech unit controller can be connected to a variety of field installed sensors.

- Space Sensor with tenant override – Daikin Applied PN: 113117701
- DDC Space Sensor with Setpoint Adjust and Tenant Override – Daikin Applied PN: 910143408
- Combo DDC Temp and Humidity Sensor with Setpoint Adj and Tnt Ovrd – Daikin Applied PN: 910191961
- Communicating Network Space Sensors – Daikin Applied PN: 910279216 and 910278050
- Space Humidity Sensor – Daikin Applied PN: 910202119
- Wall Mounted CO2 Sensor – Daikin Applied PN: 107287012
- Duct Mounted CO2 Sensor – Daikin Applied PN: 910111672

### Space Temperature Sensors

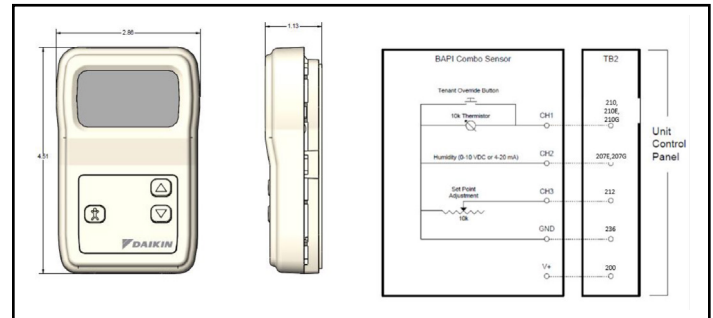
The Rebel Applied MicroTech works with 10kohm Class II thermistors and can support up to 3 sensors. These sensors can drive cooling and heating based on the highest, lowest, or average space sensor reading.

## DDC Space Sensors

The Rebel Applied MicroTech works with 10kohm Class II thermistors and can support up to 3 sensors. These sensors can drive cooling and heating based on the highest, lowest, or average space sensor reading. A Combo sensor version provides temperature and humidity.

**NOTE:** Only one sensor can drive the setpoint adjustment.

**Figure 186: Daikin Applied Space Sensor**



## Communicating Network Space Sensors

The MicroTech unit controller can be connected to a Network of the 3 space sensors as either a temperature sensor only or a temperature, Humidity and CO<sub>2</sub> combo sensor. Each Sensor comes with a backlit LCD screen to show current space conditions, allow setpoint adjustment and communicate commands.

- Network Temperature Sensor – Daikin Applied Part Number 910279216
- Network Combo Temperature Sensor – Daikin Applied Part Number 910278050

**Figure 187: Network Space Sensor**



The MicroTech can support up to 3 Network (QMX) sensors wired to the Process Bus terminals with a Daisy Chain Twisted pair. Refer to [QM 1373](#) for MicroTech configuration and set-up instructions

**NOTE:** The sensor is available in English units only and does not show SI units.

Figure 188: Process Bus Wiring Connections

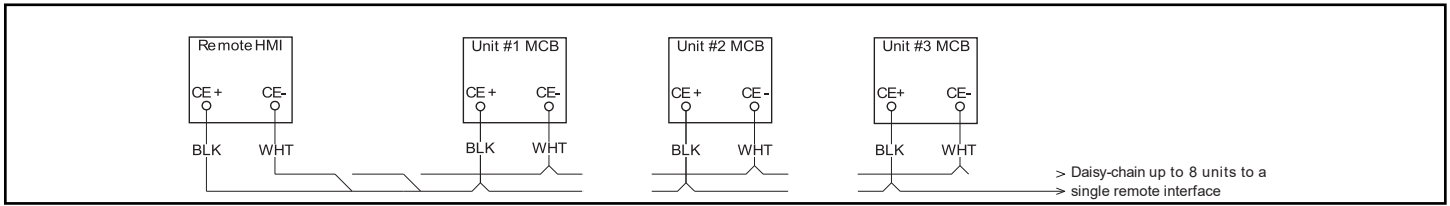
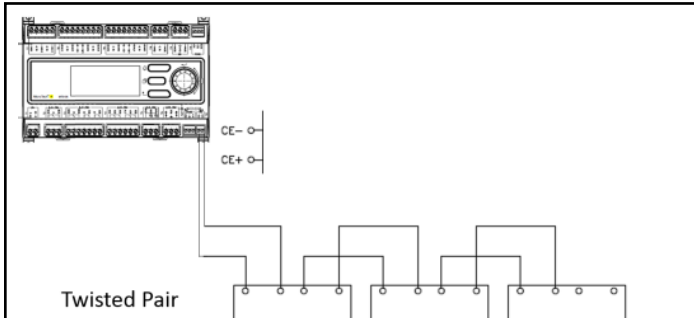


Figure 189: QMX Sensor



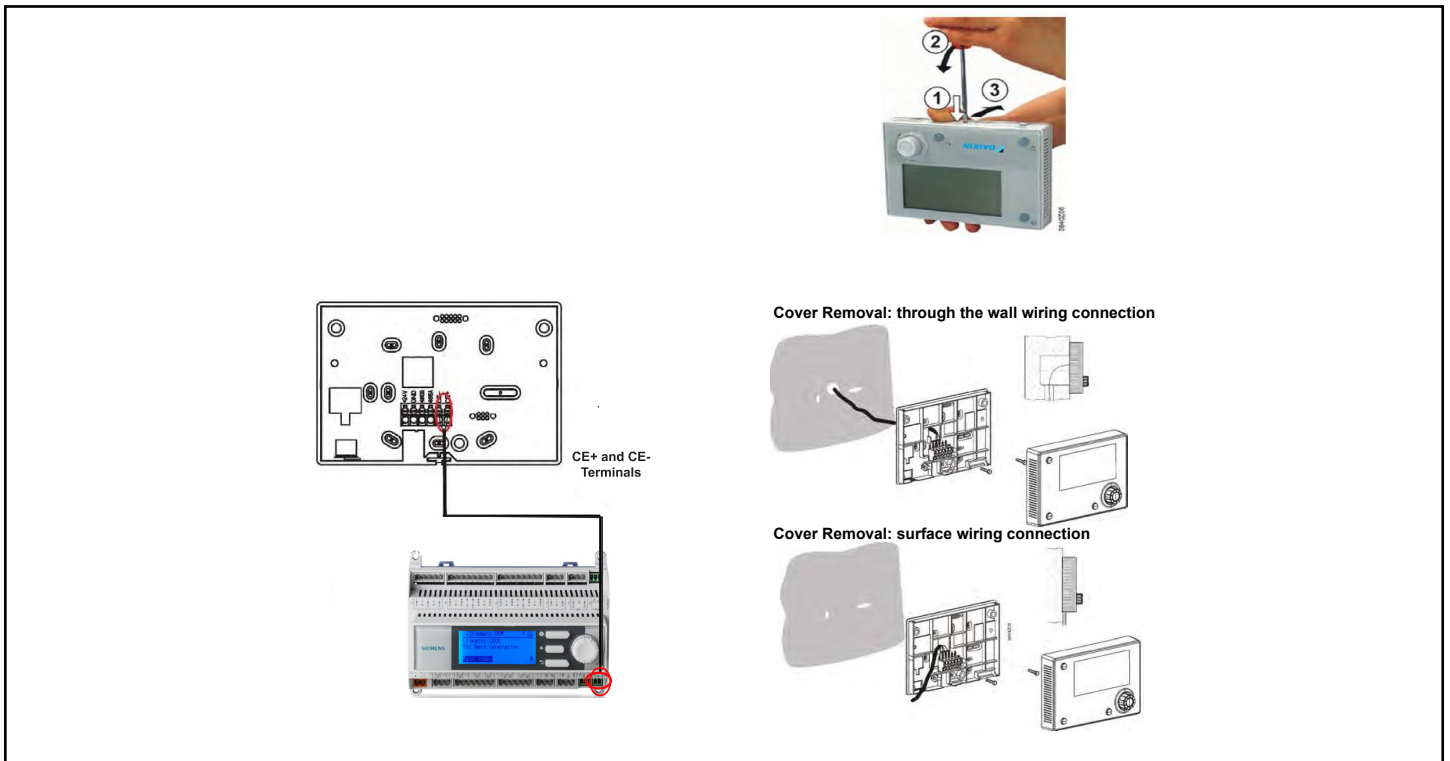
Refer to OM 1373 for MicroTech configuration and set-up instructions.

**NOTE:** The sensor is available in English units and does not show SI units.

Table 30: Specifications

Interface	
Process Bus	Up to eight interfaces per remote
Bus Connection	CE+, CE- not interchangeable
Terminal	2-screw connector
Max. Length	700 meters
Cable Type	Twisted pair cable, 0.5 ... 2.5 mm <sup>2</sup>
Display	
LCD Type	FSTN
Dimensions	5.7(w) × 3.8(h) × 1.5(d) inches [114 × 96 × 38] mm
Resolution	Dot-matrix 96 × 208 pixels
Backlight	Blue or white, user configurable
Environmental Conditions	
Operation	IEC 721-3-3
Temperature	-40°C to 70°C
Restriction LCD	-20° to 60°
Humidity	<90% r.h. (no condensation)
Air Pressure	Min. 700hPa, corresponding to max. 3,000 (m) above sea level

Figure 190: Connections




## Temperature Sensor Scaling


The MicroTech unit controller uses passive negative temperature coefficient (NTC) 10K ohm sensors. These sensors vary their input resistance to the MCB as the temperature changes.


**Table 31: Nominal Input Resistance Versus Temperature**

Temperature			R nominal (Ω)	Temperature			R nominal (Ω)	Temperature			R nominal (Ω)	Temperature			R nominal (Ω)				
°F	°C			°F	°C			°F	°C			°F	°C			°F	°C		
-40	-40.0		336.050	-6	-21.1		103.486	28	-2.2		36.601	62	16.7		14.546	96	35.6		6.382
-39	-39.4		323.889	-5	-20.6		100.184	29	-1.7		35.565	63	17.2		14.179	97	36.1		6.238
-38	-38.9		312.212	-4	-20.0		96.999	30	-1.1		34.562	64	17.8		13.822	98	36.7		6.097
-37	-38.3		300.999	-3	-19.4		93.927	31	-0.6		33.591	65	18.3		13.475	99	37.2		5.960
-36	-37.8		290.229	-2	-18.9		90.962	32	0.0		32.650	66	18.9		13.139	100	37.8		5.826
-35	-37.2		279.884	-1	-18.3		88.101	33	0.6		31.739	67	19.4		12.811	101	38.3		5.696
-34	-36.7		269.945	0	-17.8		85.340	34	1.1		30.856	68	20.0		12.493	102	38.9		5.569
-33	-36.1		260.396	1	-17.2		82.676	35	1.7		30.000	69	20.6		12.184	103	39.4		5.446
-32	-35.6		251.218	2	-16.7		80.103	36	2.2		29.171	70	21.1		11.884	104	40.0		5.325
-31	-35.0		242.397	3	-16.1		77.620	37	2.8		28.368	71	21.7		11.591	105	40.6		5.208
-30	-34.4		233.918	4	-15.6		75.222	38	3.3		27.590	72	22.2		11.307	106	41.1		5.093
-29	-33.9		225.766	5	-15.0		72.906	39	3.9		26.835	73	22.8		11.031	107	41.7		4.981
-28	-33.3		217.928	6	-14.4		70.670	40	4.4		26.104	74	23.3		10.762	108	42.2		4.872
-27	-32.8		210.390	7	-13.9		68.510	41	5.0		25.394	75	23.9		10.501	109	42.8		4.766
-26	-32.2		203.139	8	-13.3		66.424	42	5.6		24.707	76	24.4		10.247	110	43.3		4.663
-25	-31.7		196.165	9	-12.8		64.408	43	6.1		24.040	77	25.0		10.000	111	43.9		4.562
-24	-31.1		189.455	10	-12.2		62.460	44	6.7		23.394	78	25.6		9.760	112	44.4		4.463
-23	-30.6		182.998	11	-11.7		60.578	45	7.2		22.767	79	26.1		9.526	113	45.0		4.367
-22	-30.0		176.785	12	-11.1		58.759	46	7.8		22.159	80	26.7		9.298	114	45.6		4.273
-21	-29.4		170.804	13	-10.6		57.001	47	8.3		21.569	81	27.2		9.077	115	46.1		4.182
-20	-28.9		165.048	14	-10.0		55.301	48	8.9		20.997	82	27.8		8.862	116	46.7		4.093
-19	-28.3		159.506	15	-9.4		53.658	49	9.4		20.442	83	28.3		8.652	117	47.2		4.006
-18	-27.8		154.169	16	-8.9		52.069	50	10.0		19.903	84	28.9		8.448	118	47.8		3.921
-17	-27.2		149.030	17	-8.3		50.533	51	10.6		19.380	85	29.4		8.249	119	48.3		3.838
-16	-26.7		144.081	18	-7.8		49.047	52	11.1		18.873	86	30.0		8.056	120	48.9		3.757
-15	-26.1		139.313	19	-7.2		47.610	53	11.7		18.380	87	30.6		7.868	121	49.4		3.678
-14	-25.6		134.720	20	-6.7		46.220	54	12.2		17.902	88	31.1		7.685	122	50.0		3.601
-13	-25.0		130.295	21	-6.1		44.875	55	12.8		17.438	89	31.7		7.506	123	50.6		3.526
-12	-24.4		126.031	22	-5.6		43.574	56	13.3		16.988	90	32.2		7.333	124	51.1		3.453
-11	-23.9		121.921	23	-5.0		42.315	57	13.9		16.551	91	32.8		7.164	125	51.7		3.381
-10	-23.3		117.960	24	-4.4		41.097	58	14.4		16.126	92	33.3		6.999	126	52.2		3.311
-9	-22.8		114.141	25	-3.9		39.917	59	15.0		15.714	93	33.9		6.839	127	52.8		3.243
-8	-22.2		110.460	26	-3.3		38.776	60	15.6		15.313	94	34.4		6.682	128	53.3		3.176
-7	-21.7		106.910	27	-2.8		37.671	61	16.1		14.924	95	35.0		6.530	129	53.9		3.111

## R-32 Guidelines

 <b>WARNING</b>	
 <b>A2L</b>	<p>This unit contains R-32, a class A2L refrigerant that is flammable. This unit should only be installed, serviced, repaired, and disposed of by qualified personnel licensed or certified in their jurisdiction to work with R-32 refrigerant. Installation and maintenance must be done in accordance with this manual. Improper handling of this equipment can cause personal injury or equipment damage.</p>
<p>Be aware that R-32 refrigerant may not contain an odor. Place in a well ventilated area to prevent accumulation of refrigerant. Excessive refrigerant leaks, in the event of an accident in a closed ambient space, can lead to oxygen deficiency.</p> <p>Do not pierce or burn this unit.</p> <p>Never use an open flame during service or repair. Never store in a room with continuously operating ignition sources (for example: open flames, an operating gas appliance, or an operating electric heater), where there is ignitable dust suspension in the air, or where volatile flammables such as thinner or gasoline are handled.</p> <p>Only use pipes, nuts, and tools intended for exclusive use with R-32 refrigerant in compliance with national codes (ASHRAE15 or IRC).</p> <p>Do not mix air or gas other than R-32 in the refrigerant system. If air enters the refrigerant system, an excessively high pressure results, which may cause equipment damage or injury.</p> <p>Do not use means to accelerate the defrosting process or to clean, other than those recommended by the manufacturer.</p>	

 <b>DANGER</b>	
<p><b>LOCKOUT/TAGOUT</b> all power sources prior to servicing the unit or opening any panels or doors. This Appliance is equipped with a Refrigerant Leak Detection system and the system components such as supply fans may begin operation unexpectedly and without warning.</p>	

 <b>WARNING</b>	
<p>The appliance is designed to activate leak mitigation airflow in the event a refrigerant leak is detected. This is required to ensure dilution and prevent stagnation of any leaked refrigerant. Always ensure the supply fans are able to operate freely. Always maintain proper airflow and do not allow filters, air inlets, or air outlets to become blocked.</p>	

### Safety Considerations

This unit is equipped with an A2L (R32) refrigerant and a Refrigerant Leak Detection and Mitigation system. In the unlikely event of a refrigerant leak the unit may take mitigation actions such as activating dilution airflow or disabling certain unit functions. For full details on the mitigation modes and sequence of operation, refer to the literature for the unit controller and A2L mitigation control board. For connection to customer control systems or a Building Management System a field connection is provided with the unit controls. Refer to the unit specific electrical schematic for the connection details.

Maintaining and servicing R-32 refrigerant should only be performed as recommended by this manual and by personnel licensed or certified in their jurisdiction to handle A2L refrigerants under a controlled procedure. Dismantling the unit and treatment of the refrigerant, oil, and additional parts must be done in accordance with the relevant local, state, and national regulations.

Only use tools meant for use on R-32 refrigerant, such as a gauge manifold, charge hose, gas leak detector, reverse flow check valve, refrigerant charge base, vacuum gauge, or refrigerant recovery equipment.

### Field Installation Considerations

All Field installed or modified refrigerant containing pipe-work including piping material, pipe routing, and installation shall include protection from physical damage in operation and service, and be in compliance with national and local codes and standards, such as ASHRAE 15, ASHRAE 15.2, IAPMO Uniform Mechanical Code, ICC International Mechanical Code, or CSA B52. All field joints shall be accessible for inspection prior to being covered or enclosed.

After completion of any field installed piping for split systems the pipework shall be pressure tested with an inert gas and vacuum tested prior to being charged with refrigerant per the following procedure:

1. The minimum test pressure for the low side of the system shall be the low side design pressure and the minimum test pressure for the high side of the system shall be the high side design pressure, unless the high side of the system, cannot be isolated from the low side of the system in which case the entire system shall be pressure tested to the low side design pressure.
2. Field-made refrigerant joints indoors shall be tightness tested. The test method shall have a sensitivity of 5 grams per year of refrigerant or better under a pressure of at least 0.25 times the maximum allowable pressure. No leak shall be detected.

## Minimum Room Area



### WARNING

Failure to maintain the required Minimum Room Area for leaked refrigerant dilution may result in property damage, personal injury, or death.

The Rebel Applied units are certified as “Enhanced Tightness Refrigerating Systems” per UL60335-2-40 safety standard. In the unlikely event of a refrigerant leak the equipment leak detection system will activate the supply fans to a pre-set speed. This speed corresponds to an airflow that is always greater than 141 CFM. 141 CFM is the minimum required airflow rate to dilute any leaked refrigerant and prevent stagnation, the actual unit airflow may be much higher depending on configuration.

This unit contains an A2L refrigerant (R-32). The served indoor space must be larger than or equal to the Minimum Room Area as shown in [Figure 191 on page 105](#). In the unlikely event of a refrigerant leak this room area must meet this requirement to ensure dilution and prevent stagnation of any leaked refrigerant.

The Refrigerant Charge of each unit is stated on the Unit Dataplate and should be used to confirm the Minimum Room Area prior to installation.

When the appliance is connected to an unventilated space the following rules shall apply to determine if connected spaces can be used in the Minimum Room Area calculation. The room area shall be defined as the room area enclosed by the projection to the floor of the walls, partitions and doors of the space in which the unit serves. Spaces connected by only drop ceilings, ductwork, or similar connections shall not be considered a single space. Rooms on the same floor and connected by an open passageway between the spaces can be considered a single room when determining compliance to Minimum Room Area, if the passageway complies with all of the following:

- It is a permanent opening.
- It extends to the floor.
- It is intended for people to walk through.

The area of the adjacent rooms, on the same floor, connected by a permanent opening in the walls and/or doors between occupied spaces, including gaps between the wall and the floor, can be considered a single room when determining compliance to the Minimum Room Area, provided all of the following are met:

- The minimum opening area connecting the spaces/rooms shall not be less than 0.0123 m<sup>2</sup>.
- The area of any openings above 300 mm from the floor shall not be considered part of the minimum opening area.
- At least 50 % of the minimum opening area shall be below 200 mm from the floor.
- Openings are permanent openings which cannot be closed.
- For openings extending to the floor the height shall not be less than 20 mm above the surface of the floor covering.
- A second higher opening shall be provided. The total size of the second opening shall not be less than 50% of the minimum opening area and shall be at least 1.5 m above the floor.

**NOTE:** The requirement for the second opening can be met by drop ceilings, ventilation ducts, or similar arrangements that provide an airflow path between the connected rooms.

### Altitude Considerations for Minimum Room Area

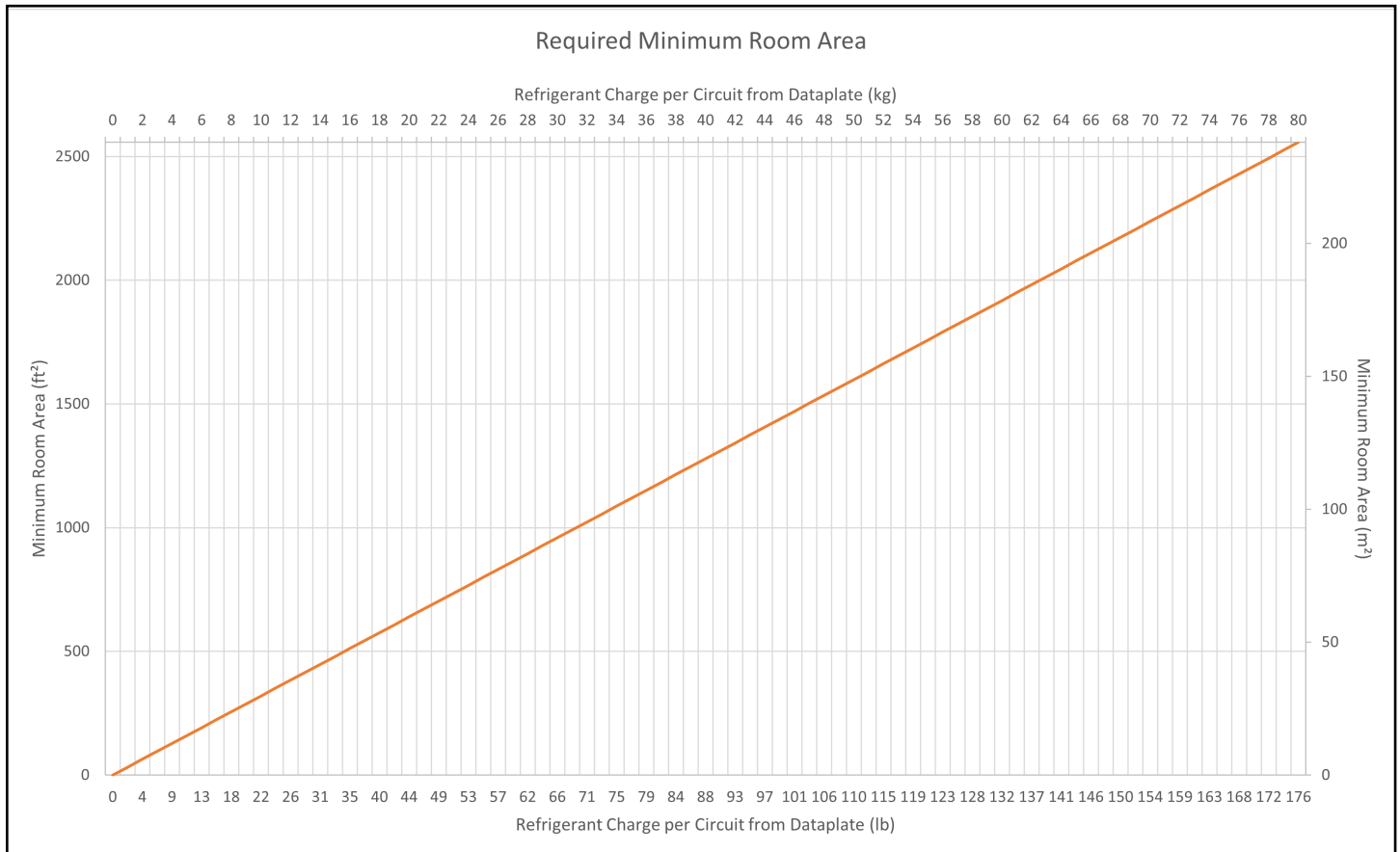
When the unit is installed at altitude above sea level the minimum room area must be adjusted by the multiplier shown in [Table 32 on page 105](#). This will increase the required minimum room area of the served space.

If the actual room area served by the appliance is not large enough to meet the Minimum Room Area additional measures such as mechanical ventilation of the space may need to be employed. Please contact Daikin Applied for additional information.

**Table 32: Minimum Room Area Multipliers by Altitude**

Altitude (Meters)	Minimum Room Area Multiplier
0	1
305	1.047
500	1.078
750	1.117
1000	1.156
1250	1.195
1500	1.234
1750	1.273
2000	1.312
2250	1.351
2500	1.39
2750	1.429
3000	1.468
3250	1.507
3500	1.546

**Figure 191: Required Minimum Room Area Chart**



## Leak Mitigation System and Sensors

For Additional Instructions on how to operate the Leak Mitigation System including how to activate a manual test of the Leak Mitigation System, refer to the unit controller manual.

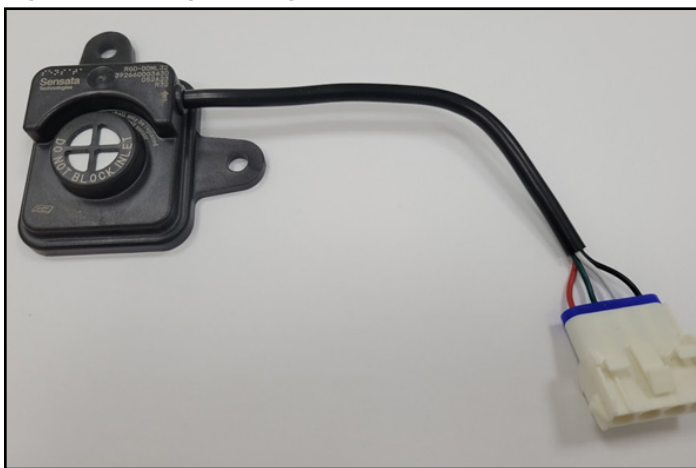
### **WARNING**

This equipment is equipped with a Refrigerant Leak Detection System. Only components and Refrigerant Detection Sensors specified by Daikin Applied may be used for replacement and maintenance.

### **WARNING**

Always ensure the Refrigerant Detection Sensors installed in the equipment are free of debris and the inlet is not blocked. If replacing a Refrigerant Detection Sensor always install in the identical orientation as the original sensor.

**Figure 192: Sample Refrigerant Detection Sensor**



**NOTE:** Identify the sensor inlet marked “Do Not Block Inlet”.

### **WARNING**

Auxiliary devices which may be a Potential Ignition Source shall not be installed in the duct work. Examples of such Potential Ignition Sources are hot surfaces with a temperature exceeding 1292°F (700°C) and electric switching devices.

### **WARNING**

The unit must be stored and/or located to prevent mechanical damage of the refrigeration system. Do not store the unit near sources of open flame, electrical switching devices, or hot surfaces above 1292°F (700°C). If the unit is stored indoors the storage area should be larger than the Minimum Room Area specified in this manual. The storage space should be well ventilated and not allow for the stagnation of leaked refrigerant. Failure to do so may result in a fire or explosion hazard.

### **WARNING**

Only auxiliary devices approved by Daikin Applied or declared suitable for installation with R-32 shall be installed in the connecting ductwork.

## Performing Service

### **Remove Ignition Sources**

Always perform a safety check of the area to ensure the risk of ignition is minimized before servicing the unit.

### **Personnel Awareness**

Inform maintenance staff and others working in the local area of the nature of work being carried out. Only personnel attending to the refrigerant system should be present.

### **Check for Presence of Airborne Refrigerant**

Check the area with an appropriate refrigerant detector prior to and during work to ensure all personnel are aware of potentially toxic or flammable gases in the air. Ensure that the leak detection equipment being used is suitable for use with all applicable refrigerants; i.e., non-sparking, adequately sealed or intrinsically safe.

### **Presence of fire extinguisher**

If any hot work is to be conducted on the refrigerating equipment or any associated parts, appropriate fire extinguishing equipment should be available to hand. Have a dry powder or CO2 fire extinguisher adjacent to the charging area.

### **No Ignition Sources**

No person carrying out work in relation to a REFRIGERATING SYSTEM which involves exposing any pipe work shall use any sources of ignition in such a manner that it may lead to the risk of fire or explosion. All possible ignition sources, including cigarette smoking, should be kept sufficiently far away from the site of installation, repairing, removing and disposal, during which refrigerant can possibly be released to the surrounding space. Prior to work taking place, the area around the equipment is to be surveyed to make sure that there are no flammable hazards or ignition risks. “No Smoking” signs shall be displayed.

### **Ventilated area**

Ensure that the area is in the open or that it is adequately ventilated before breaking into the system or conducting any hot work. A degree of ventilation shall continue during the period that the work is carried out.

### **Checks to the refrigerating equipment**

Where electrical components are being changed, they shall be fit for the purpose and to the correct specification. At all times the manufacturer’s maintenance and service guidelines shall be followed. If in doubt, consult the manufacturer’s technical department for assistance.

The following checks shall be applied to installations using FLAMMABLE REFRIGERANTS:

- The actual REFRIGERANT CHARGE is in accordance with the room size within which the refrigerant containing parts are installed.
- The ventilation machinery and outlets are operating adequately and are not obstructed.

- If an indirect refrigerating circuit is being used, the secondary circuit shall be checked for the presence of refrigerant.
- Marking to the equipment continues to be visible and legible. Markings that are illegible shall be corrected.
- Refrigerating pipe or components are installed in a position where they are unlikely to be exposed to any substance which may corrode refrigerant containing components, unless the components are constructed of materials which are inherently resistant to being corroded or are suitably protected against being so corroded.

### Checks to electrical devices

Repair and maintenance to electrical components shall include initial safety checks and component inspection procedures. If a fault exists that could compromise safety, then no electrical supply shall be connected to the circuit until it is satisfactorily dealt with. If the fault cannot be corrected immediately but it is necessary to continue operation, an adequate temporary solution shall be used. This shall be reported to the owner of the equipment so all parties are advised.

Initial safety checks shall include:

- that capacitors are discharged: this shall be done in a safe manner to avoid possibility of sparking;
- that no live electrical components and wiring are exposed while charging, recovering or purging the system;
- that there is continuity of earth bonding.

### Repairs to sealed components

Sealed electrical components must be replaced.

### Repair to intrinsically safe components

Intrinsically safe components must be replaced.

### Cabling

- Check that cabling will not be subject to wear, corrosion, excessive pressure, vibration, sharp edges or any other adverse environmental effects. The check shall also take into account the effects of aging or continual vibration from sources such as compressors or fans.

### Detection of flammable refrigerants

- Under no circumstances shall potential sources of ignition be used in the searching for or detection of refrigerant leaks. A halide torch (or any other detector using a naked flame) shall not be used.
- The following leak detection methods are deemed acceptable for all refrigerant systems.
- Electronic leak detectors may be used to detect refrigerant leaks but, in the case of FLAMMABLE REFRIGERANTS, the sensitivity may not be adequate, or may need re-calibration. (Detection equipment shall be calibrated in a refrigerant-free area.) Ensure that the detector is not a potential source of ignition and is suitable for the refrigerant used. Leak detection equipment shall be set at a percentage of the LFL of the refrigerant and shall be

calibrated to the refrigerant employed, and the appropriate percentage of gas (25 % maximum) is confirmed.

- Leak detection fluids are also suitable for use with most refrigerants but the use of detergents containing chlorine shall be avoided as the chlorine may react with the refrigerant and corrode the copper pipe-work.

**NOTE:** Examples of leak detection fluids are:

- bubble method; or
- fluorescent method agents.

- If a leak is suspected, all naked flames shall be removed/ extinguished.
- If a leakage of refrigerant is found which requires brazing, all of the refrigerant shall be recovered from the system, or isolated (by means of shut off valves) in a part of the system remote from the leak. Removal of refrigerant shall be according to instructions above.

### Removal and evacuation

- When breaking into the refrigerant circuit to make repairs, or for any other purpose, conventional procedures shall be used. However, for flammable refrigerants it is important that best practice be followed, since flammability is a consideration.
- The following procedure shall be adhered to:
  - a. Safely remove refrigerant following local and national regulations.
  - b. Evacuate refrigerant from circuit.
  - c. Purge the circuit with inert gas.
  - d. Evacuate (optional for A2L).
  - e. Purge the inert gas (optional for A2L)
  - f. Continuously flush or purge with inert gas when using flame to open circuit.
  - g. Open the circuit by cutting or brazing.
- The refrigerant charge shall be recovered into the correct recovery cylinders. For appliances containing flammable refrigerants, the system shall be purged with oxygen-free nitrogen to render the appliance safe for flammable refrigerants. This process might need to be repeated several times.
- Compressed air or oxygen shall not be used for purging refrigerant systems.
- For appliances containing flammable refrigerants, refrigerants purging shall be achieved by breaking the vacuum in the system with oxygen-free nitrogen and continuing to fill until the working pressure is achieved, then venting to atmosphere, and finally pulling down to a vacuum.
- When the final oxygen-free nitrogen charge is used, the system shall be vented down to atmospheric pressure to enable work to take place.
- Ensure that the outlet for the vacuum pump is not close to any potential ignition sources and that ventilation is available.

## Charging procedures

### ***In addition to conventional charging procedures, the following requirements shall be followed.***

- Ensure that contamination of different refrigerants does not occur when using charging equipment.
- Hoses or lines shall be as short as possible to minimise the amount of refrigerant contained in them.
- Cylinders shall be kept in an appropriate position according to the instructions.
- Ensure that the REFRIGERATING SYSTEM is earthed prior to charging the system with refrigerant.
- Label the system when charging is complete (if not already).
- Extreme care shall be taken not to overfill the REFRIGERATING SYSTEM.
- Prior to recharging the system, it shall be pressure-tested with the appropriate purging gas. The system shall be leak-tested on completion of charging but prior to commissioning. A follow up leak test shall be carried out prior to leaving the site.

## Decommissioning

***Before carrying out this procedure, it is essential that the technician is completely familiar with the equipment and all its detail. It is recommended good practice that all refrigerants are recovered safely.***

***Prior to the task being carried out, an oil and refrigerant sample shall be taken in case analysis is required prior to re-use of recovered refrigerant.***

***It is essential that electrical power is available before the task is commenced.***

- Become familiar with the equipment and its operation.
- Isolate system electrically.
- Before attempting the procedure, ensure that mechanical handling equipment is available, if required, for handling refrigerant cylinders; all personal protective equipment is available and being used correctly; the recovery process is supervised at all times by a competent person; recovery equipment and cylinders conform to the appropriate standards.
- Pump down refrigerant system, if possible.
- If a vacuum is not possible, make a manifold so that refrigerant can be removed from various parts of the system.
- Make sure that cylinder is situated on the scales before recovery takes place.
- Start the recovery machine and operate in accordance with instructions.
- Do not overfill cylinders (no more than 80 % volume liquid charge).

- Do not exceed the maximum working pressure of the cylinder, even temporarily.
- When the cylinders have been filled correctly and the process completed, make sure that the cylinders and the equipment are removed from site promptly and all isolation valves on the equipment are closed off.
- Recovered refrigerant shall not be charged into another REFRIGERATING SYSTEM unless it has been cleaned and checked.

## Labeling

***Equipment shall be labeled stating that it has been de-commissioned and emptied of refrigerant. The label shall be dated and signed. For appliances containing FLAMMABLE REFRIGERANTS, ensure that there are labels on the equipment stating the equipment contains FLAMMABLE REFRIGERANT.***

## Recovery

- When removing refrigerant from a system, either for servicing or decommissioning, the refrigerant must be removed safely.
- When transferring refrigerant into cylinders, ensure that only appropriate refrigerant recovery cylinders are employed. Ensure that the correct number of cylinders for holding the total system charge is available. All cylinders to be used are designated for the recovered refrigerant and labeled for that refrigerant (i.e., special cylinders for the recovery of refrigerant). Cylinders shall be complete with pressure-relief valve and associated shut-off valves in good working order. Empty recovery cylinders are evacuated and, if possible, cooled before recovery occurs.
- The recovery equipment shall be in good working order with a set of instructions concerning the equipment that is at hand and shall be suitable for the recovery of all appropriate refrigerants including, when applicable, FLAMMABLE REFRIGERANTS. In addition, a set of calibrated weighing scales shall be available and in good working order. Hoses shall be complete with leak-free disconnect couplings and in good condition. Before using the recovery machine, check that it is in satisfactory working order, has been properly maintained and that any associated electrical components are sealed to prevent ignition in the event of a refrigerant release. Consult manufacturer if in doubt.
- The recovered refrigerant shall be returned to the refrigerant supplier in the correct recovery cylinder, and the relevant waste transfer note arranged. Do not mix refrigerants in recovery units and especially not in cylinders.

***If compressors or compressor oils are to be removed, ensure that they have been evacuated to an acceptable level to make certain that FLAMMABLE REFRIGERANT does not remain within the lubricant.***

**The evacuation process shall be carried out prior to returning the compressor to the suppliers. Only electric heating to the compressor body shall be employed to accelerate this process. When oil is drained from a system, it shall be carried out safely.**

## Lubrication

R-32 should only be used with manufacturer-approved oil, such as DAPHNE FW68DE. The HFC refrigerant components in R-32 will not be compatible with mineral oil or alkylbenzene lubricants. R-32 systems will be charged with the OEM recommended lubricant, ready for use with R-32.

## Leak Detection

NEVER use the following when attempting to detect R-32 refrigerant leaks:

- A halide torch (or any other detector using a naked flame)
- Substances containing chlorine

## Pressure Testing and Refrigerant Evacuation

- Make sure that air or any matter other than R-32 refrigerant does not enter the refrigeration cycle.
- If refrigerant gas leaks occur in an enclosed area, ventilate the space as soon as possible.
- R-32 should always be recovered and never released directly into the environment.
- Only use tools meant for use on R-32 refrigerant (such as a gauge manifold, charging hose, or vacuum pump adapter).

## Commissioning

- Ensure proper connection of all piping and carry out a leak test before charging with refrigerant.
- Check safety equipment before putting into service.

## Decommissioning

ALWAYS remove refrigerant charge before decommissioning the unit.

- Ensure sufficient ventilation at the equipment location.
- Be aware that malfunction of the equipment may be caused by refrigerant loss and a refrigerant leak is possible.
- Discharge capacitors in a way that won't cause any spark.
- R-32 should always be recovered and never released directly into the environment. Take care that the drained refrigerant will not cause any danger. In doubt, one person should guard the outlet. Take special care that drained refrigerant will not float back into the building.

## Recovery

### Recovery Cylinders

When transferring refrigerant into cylinders, ensure that only appropriate refrigerant recovery cylinders are employed. Ensure that the correct number of cylinders for holding the total system charge is available. All cylinders to be used should be designated for the recovered refrigerant and labeled for that refrigerant. Cylinders should be complete with a pressure-relief valve and associated shut-off valves in good working order. Empty recovery cylinders should be evacuated and, if possible, cooled before recovery occurs.

### Recovery Equipment

The recovery equipment should be in good working order with a set of instructions concerning the equipment that is at hand and shall be suitable for the recovery of all appropriate refrigerants including, when applicable, FLAMMABLE REFRIGERANTS. In addition, a set of calibrated weighing scales shall be available and in good working order. Hoses shall be complete with leak-free disconnect couplings and in good condition. Before using the recovery machine, check that it is in satisfactory working order, has been properly maintained and that any associated electrical components are sealed to prevent ignition in the event of a refrigerant release. Consult manufacturer if in doubt.

### Recovered Refrigerant

The recovered refrigerant should be returned to the refrigerant supplier in the correct recovery cylinder with the relevant waste transfer note assigned. Do not mix refrigerants in recovery units and especially not in cylinders.

### Compressor or Compressor Oils

If compressors or compressor oils are to be removed, ensure that they have been evacuated to an acceptable level to make certain that no refrigerant remains within the lubricant. The evacuation process should be carried out prior to returning compressors to the supplier(s). Only electric heating to the compressor body shall be employed to accelerate this process.

## Handling and Storage

### Precautions for Safe Handling

- Waste air is to be released into the atmosphere only via suitable separators. Open and handle receptacle with care.
- Keep ignition sources away.
- Do not smoke near the unit.
- Protect against electrostatic charges.

### Conditions for Safe Storage

- Requirements to be met by storerooms and receptacles:
  - Store only in unopened original receptacles
  - Store in a cool and dry location
- Further information about storage conditions:
  - Keep container tightly sealed

- Store in cool, dry conditions in well sealed receptacle
- Protect from heat and direct sunlight
- Maximum storage temperature:
  - 104°F (40°C)

## Disposal

- Waste treatment method recommendation:
  - Must be specially treated adhering to official regulations.
  - Incineration in an adequate incinerator is recommended.
  - Uncleaned packaging disposal must be made according to official regulations.
- Ensure sufficient ventilation at the working place.
- Remove the refrigerant. R-32 should always be recovered and never released directly into the environment. Take care that the drained refrigerant will not cause any danger. In doubt, one person should guard the outlet. Take special care that drained refrigerant will not float back into the building.
- Evacuate the refrigerant circuit.
- Purge the refrigerant circuit with nitrogen for 5 min.
- Evacuate again.
- Cut out the compressor and drain the oil.

## Competence of Personnel

There are specific procedures that must be followed for the installation, repair, maintenance, and decommissioning of equipment that uses A2L refrigerants.

Training for these procedures is carried out by national training organizations or manufacturers that are accredited to teach the relevant national competency standards that may be set in legislation. The achieved competence should be documented by a certificate.

## Information and Training

### *The training should include the substance of the following*

- Information about the explosion potential of flammable refrigerants to show that flammables may be dangerous when handled without care.
- Information about potential ignition sources, especially those that are not obvious, such as lighters, light switches, vacuum cleaners, electric heaters.
- Information about the different safety concepts:
  - Unventilated: Safety of the appliance does not depend on ventilation of the housing. Switching off the appliance or opening of the housing has no significant effect on safety. Nevertheless, it is possible that leaking refrigerant may accumulate inside the enclosure and flammable atmosphere will be released when the enclosure is opened.
  - Ventilated enclosure: Safety of the appliance depends on ventilation of the housing. Switching off the appliance or opening of the enclosure has a significant effect

on safety. Care should be taken to ensure sufficient ventilation before.

- Ventilated room: Safety of the appliance depends on the ventilation of the room. Switching off the appliance or opening of the housing has no significant effect on safety. The ventilation of the room shall not be switched off during repair procedures.
- Information about refrigerant detectors:
  - Principle of function, including influences on the operation.
  - Procedures, how to repair, check or replace a refrigerant detector or parts of it in a safe way.
  - Procedures, how to disable a refrigerant detector in case of repair work on the refrigerant carrying parts.
- Information about the concept of sealed components and sealed enclosures according to IEC 60079-15:2010.
- Information about the correct working procedures:
  - Commissioning
    - a. Ensure that the floor area is sufficient for the refrigerant charge or that the ventilation duct is assembled in a correct manner.
    - b. Connect the pipes and carry out a leak test before charging with refrigerant.
    - c. Check safety equipment before putting into service.
  - Maintenance
    - a. Portable equipment shall be repaired outside or in a workshop specially equipped for servicing units with flammable refrigerants.
    - b. Ensure sufficient ventilation at the repair place.
    - c. Be aware that malfunction of the equipment may be caused by refrigerant loss and a refrigerant leak is possible.
    - d. Discharge capacitors in a way that won't cause any spark. The standard procedure to short circuit the capacitor terminals usually creates sparks.
    - e. Reassemble sealed enclosures accurately. If seals are worn, replace them.
    - f. Check safety equipment before putting into service.
  - Repair
    - a. Portable equipment shall be repaired outside or in a workshop specially equipped for servicing units with flammable refrigerants.
    - b. Ensure sufficient ventilation at the repair place.
    - c. Be aware that malfunction of the equipment may be caused by refrigerant loss and a refrigerant leak is possible.
    - d. Discharge capacitors in a way that won't cause any spark.
    - e. When brazing is required, the following procedures shall be carried out in the right order:
- Removal of the refrigerant. R-32 should always be

recovered and never released directly into the environment. Take care that the drained refrigerant will not cause any danger. In doubt, one person should guard the outlet. Take special care that drained refrigerant will not float back into the building.

- Evacuation of the refrigerant circuit.
- Removal of parts to be replaced by cutting, not by flame.
- Purging the braze point with nitrogen during the brazing procedure.
- Carry out a leak test before charging with refrigerant.
  - a. Reassemble sealed enclosures accurately. If seals are worn, replace them.
  - b. Check safety equipment before putting into service.
- Decommissioning
  - a. The refrigerant charge must be removed before decommissioning.
  - b. Ensure sufficient ventilation at the equipment location.
  - c. Be aware that malfunction of the equipment may be caused by refrigerant loss and a refrigerant leak is possible.
  - d. Discharge capacitors in a way that won't cause any spark.
  - e. Remove the refrigerant. R-32 should always be recovered and never released directly into the environment. Take care that the drained refrigerant will not cause any danger. In doubt, one person should guard the outlet. Take special care that drained refrigerant will not float back into the building.
- Disposal
  - a. Ensure sufficient ventilation at the working place.
  - b. Remove the refrigerant. R-32 should always be recovered and never released directly into the environment. Take care that the drained refrigerant will not cause any danger. In doubt, one person should guard the outlet. Take special care that drained refrigerant will not float back into the building.

#### FLAMMABLE REFRIGERANTS.

- Ensure sufficient ventilation at the repair place.
- Be aware that malfunction of the equipment may be caused by refrigerant loss and a refrigerant leak is possible.
- Discharge capacitors in a way that won't cause any spark.
- When brazing is required, the following procedures shall be carried out in the right order:
  - Remove the refrigerant. R-32 should always be recovered and never released directly into the environment. Take care that the drained refrigerant will not cause any danger. In doubt, one person should guard the outlet. Take special care that drained refrigerant will not float back into the building.
  - Evacuate the refrigerant circuit.
  - Remove parts to be replaced by cutting, not by flame.
  - Purge the braze point with nitrogen during the brazing procedure.
  - Carry out a leak test before charging with refrigerant.
- Reassemble sealed enclosures accurately. If seals are worn, replace them.
- Check safety equipment before putting into service.

## Maintenance

- Equipment shall be repaired outside or in a workshop specially equipped for servicing units with A2L refrigerants.
- Ensure sufficient ventilation at the location where repairs are taking place.
- Be aware that malfunction of the equipment may be caused by refrigerant loss and a refrigerant leak is possible.
- Discharge capacitors in a way that won't cause sparks.
- When repairs are Reassemble sealed enclosures. If seals are worn, replace them.
- Check safety equipment before putting into service.

## Repair

- Portable equipment shall be repaired outside or in a workshop specially equipped for servicing units with

# Unit Maintenance

## Servicing Control Panel Components

 **WARNING**

LOCKOUT/TAGOUT all power sources before servicing this equipment. More than one disconnect may be required to de-energize unit. Moving machinery such as fans, dampers and energy recovery devices may cause injury, death, and property damage.

 **WARNING**

Exercise caution when servicing the unit. Sharp edges are inherent to sheet metal parts, screws, clips and similar items. Wear appropriate PPE such as eye protection, gloves, protective clothing, foot wear, etc., to prevent personal injury, severe personal injury, or death.

 **CAUTION**

Sharp edges are inherent to sheet metal parts, screws, clips, and similar items. May cause personal injury. Exercise caution when servicing equipment.

 **DANGER**

LOCKOUT/TAGOUT all power sources prior to servicing the unit. Hazardous voltage may cause serious injury or death.

Disconnect all electric power to the unit when servicing control panel components. Always inspect the unit for multiple disconnects to ensure all power is removed from the control panel and its components. More than one disconnect may be required to de-energize the unit.

# Example Wiring Diagram

Figure 193: Typical Rebel Applied Wiring Diagram

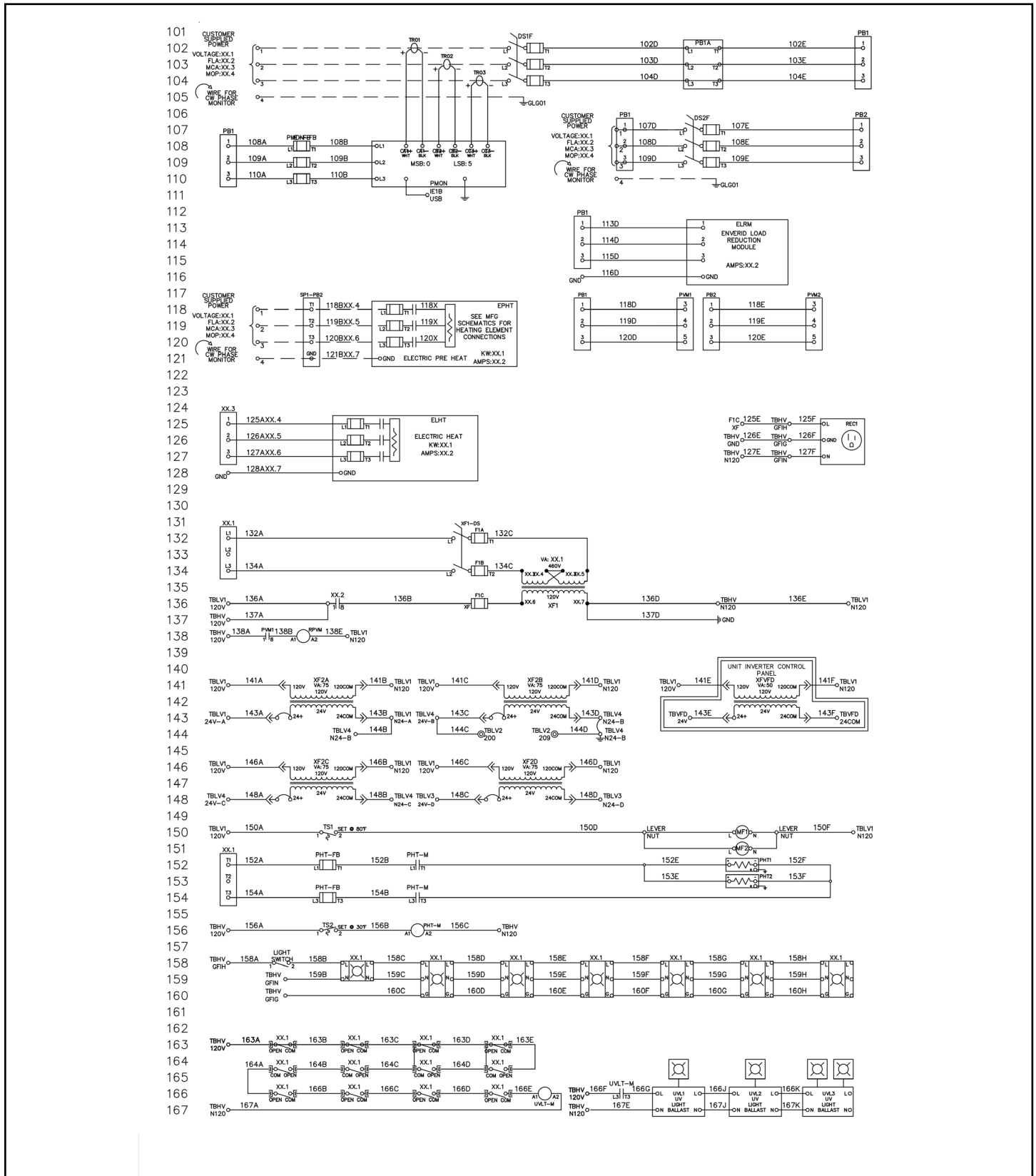


Figure 194: Typical Rebel Applied Wiring Diagram (continued)

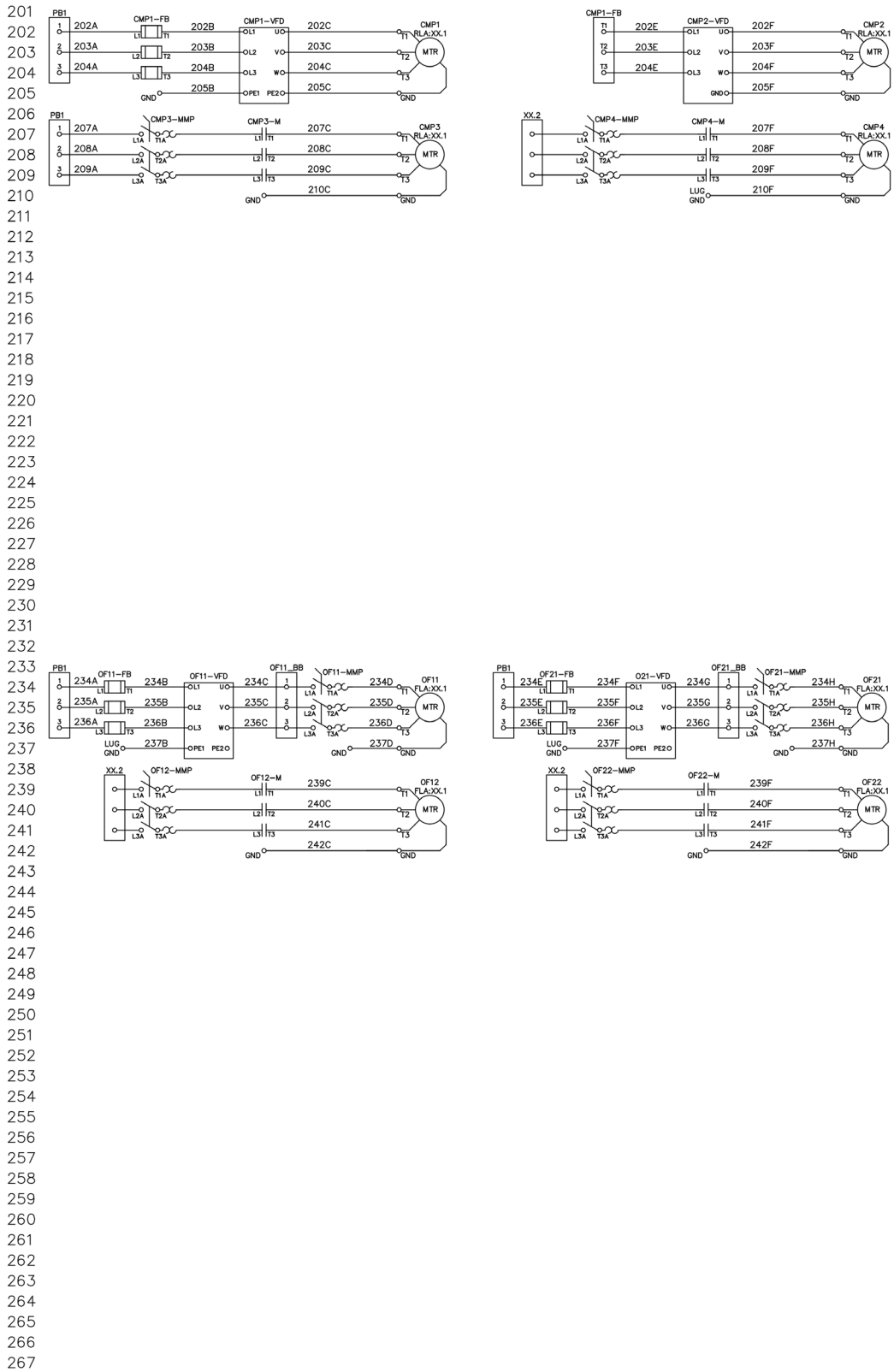


Figure 195: Typical Rebel Applied Wiring Diagram (continued)

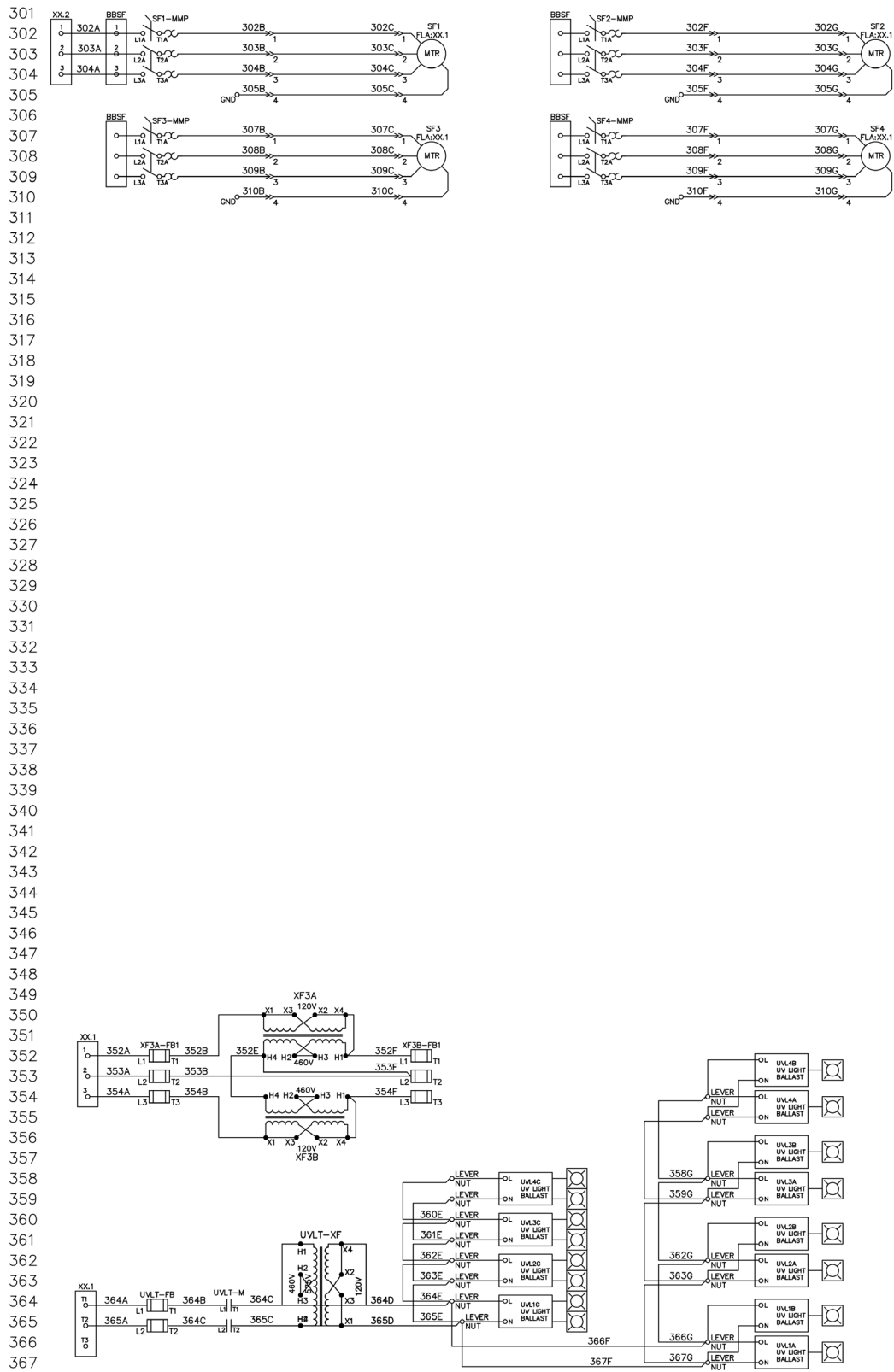


Figure 196: Typical Rebel Applied Wiring Diagram (continued)

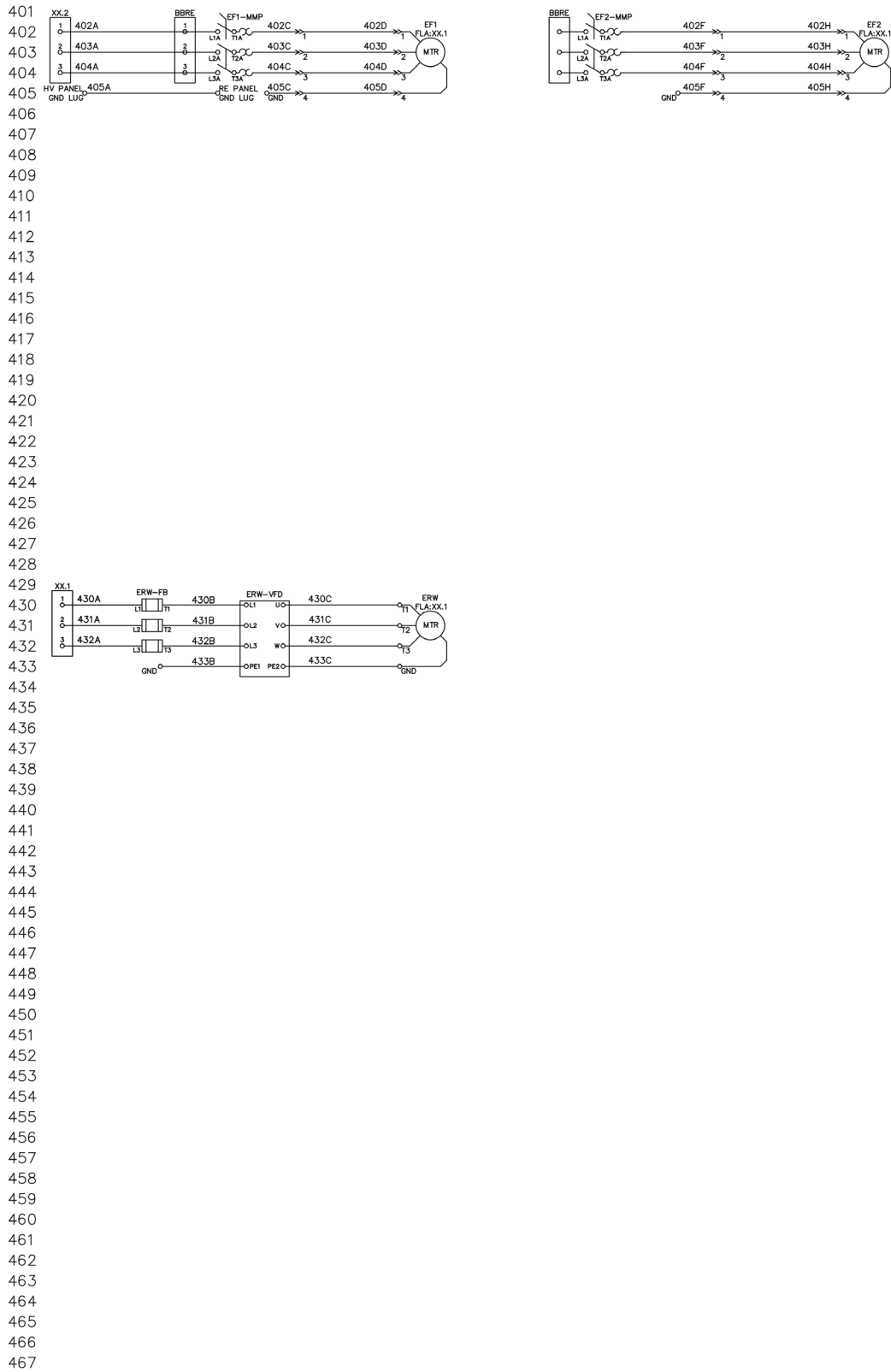


Figure 197: Typical Rebel Applied Wiring Diagram (continued)

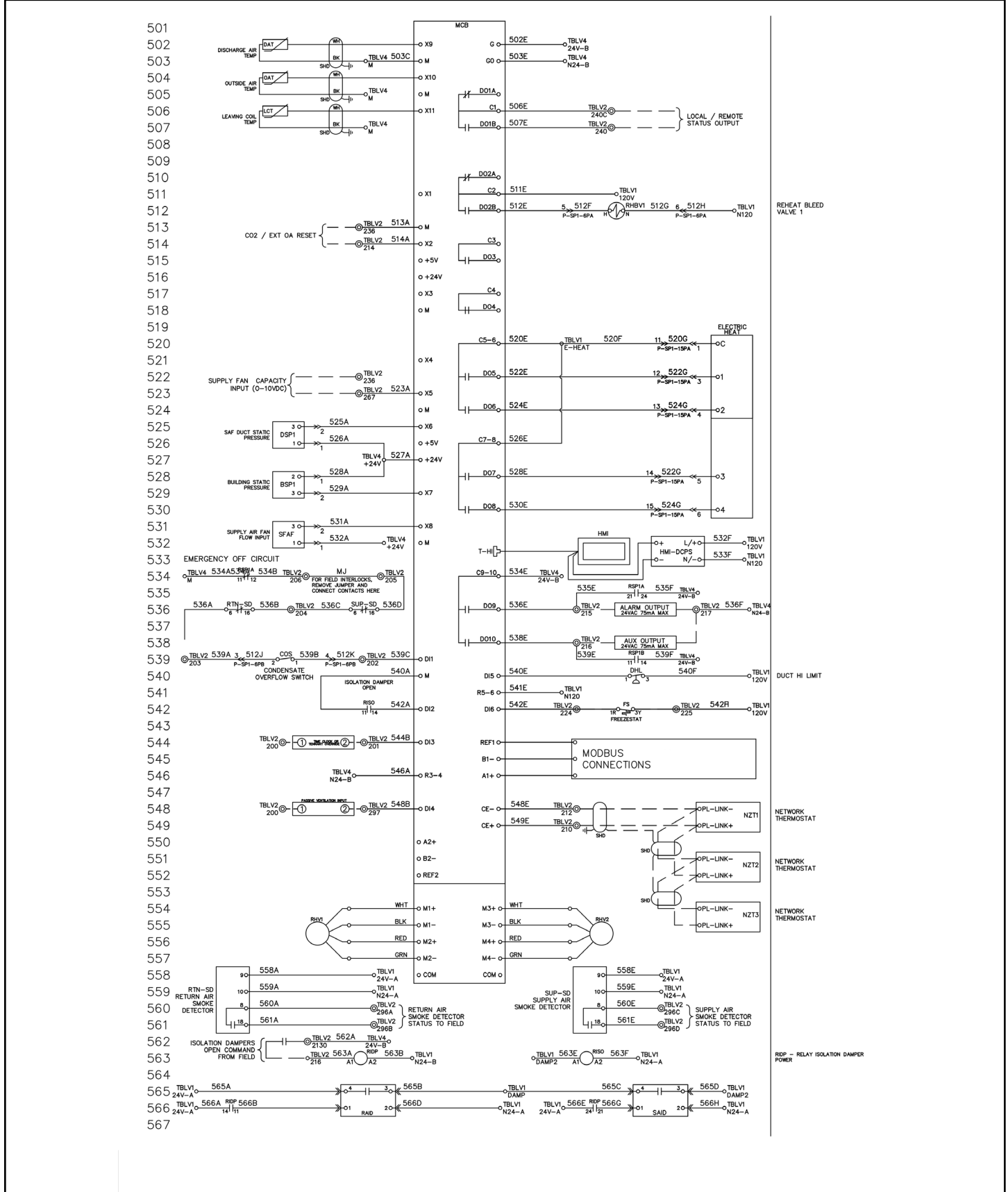


Figure 198: Typical Rebel Applied Wiring Diagram (continued)

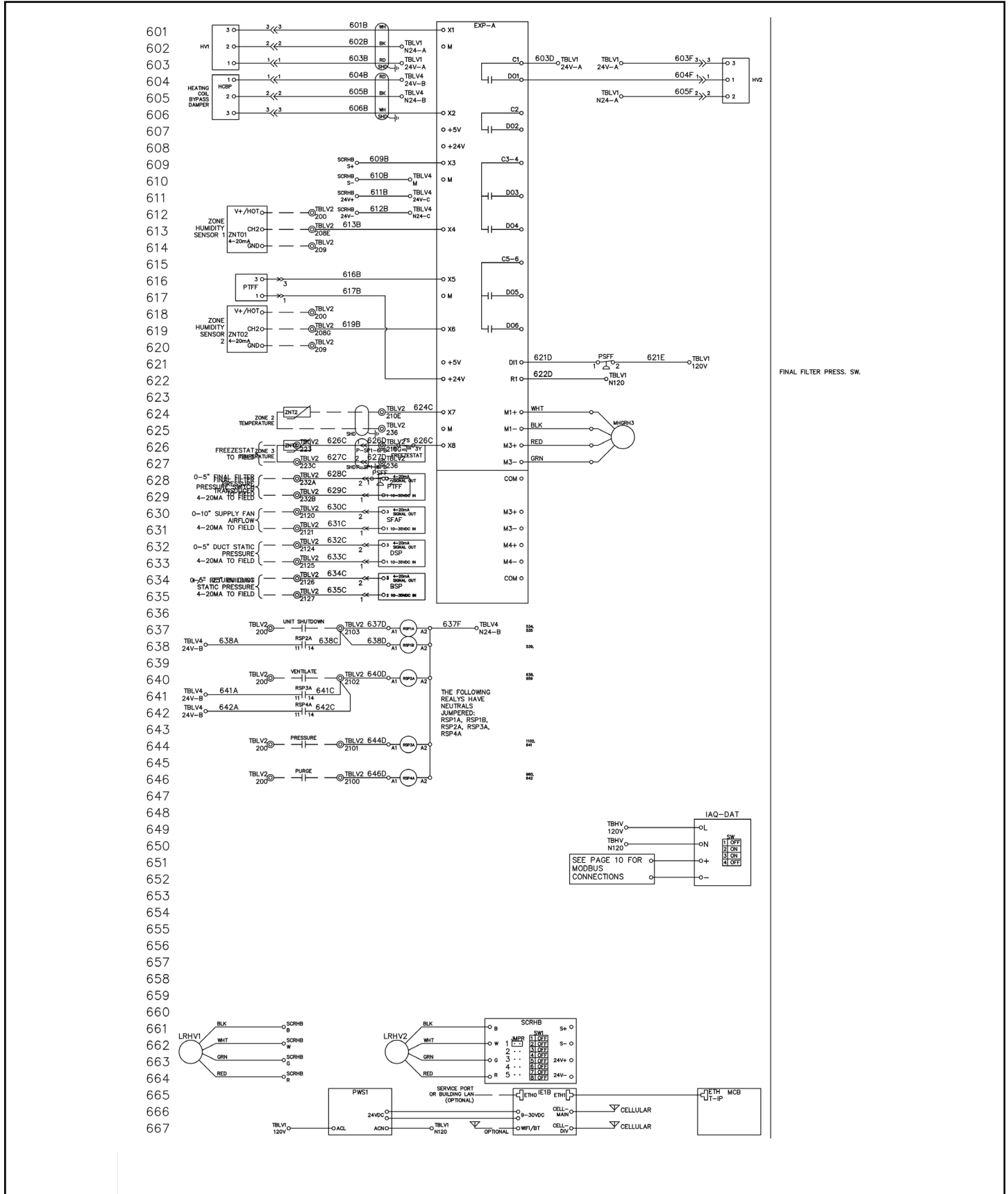


Figure 199: Typical Rebel Applied Wiring Diagram (continued)

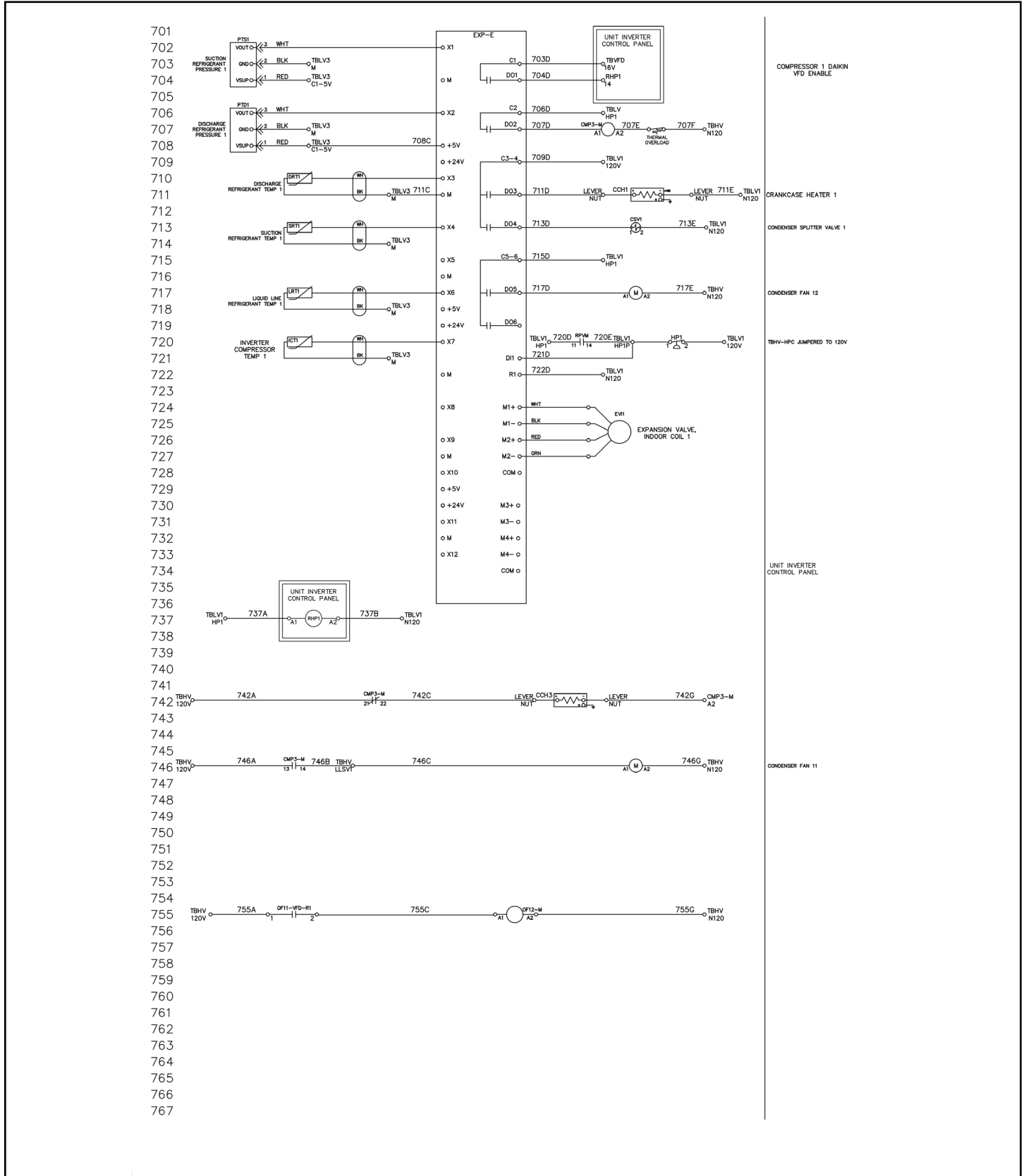


Figure 200: Typical Rebel Applied Wiring Diagram (continued)

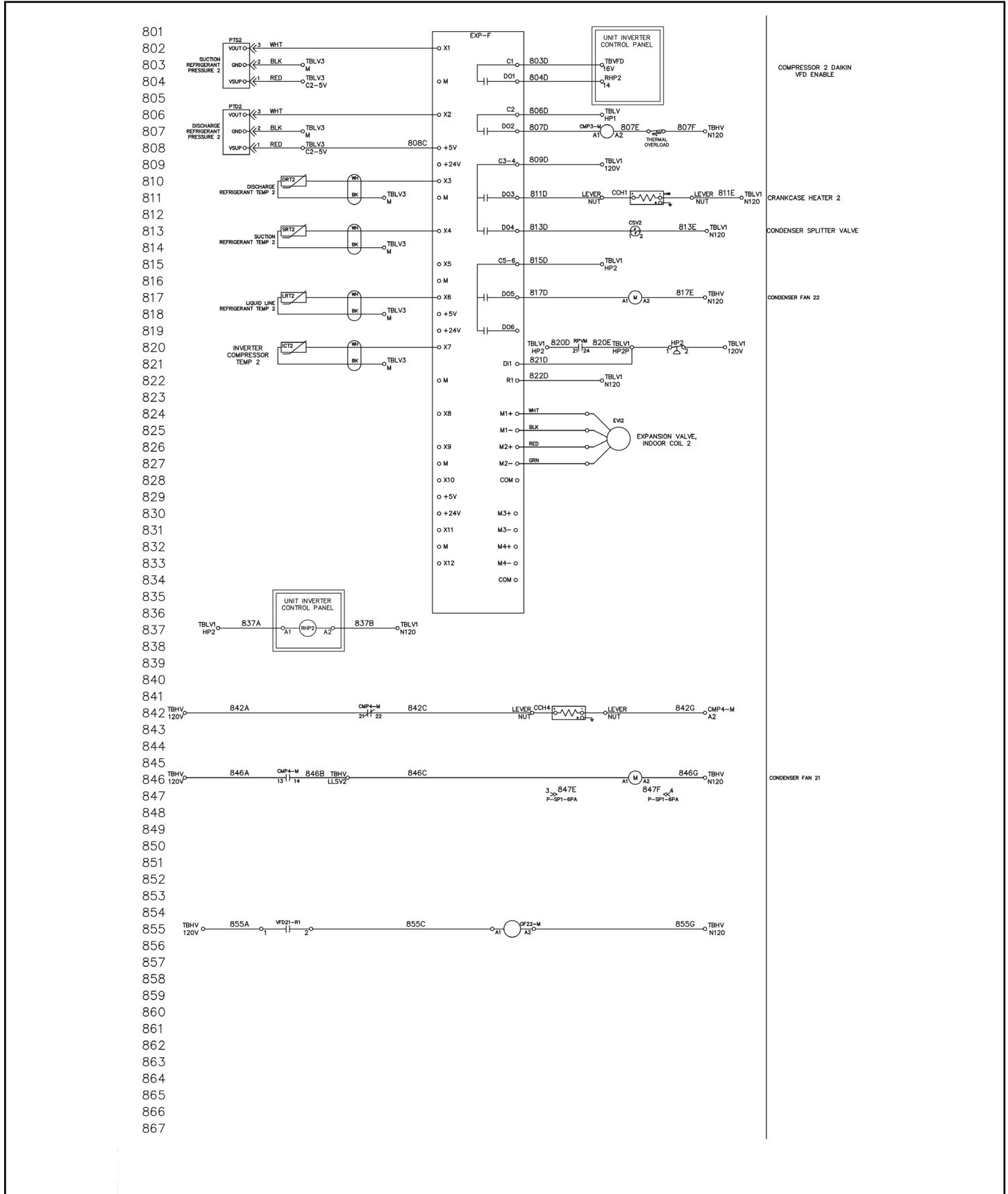


Figure 201: Typical Rebel Applied Wiring Diagram (continued)

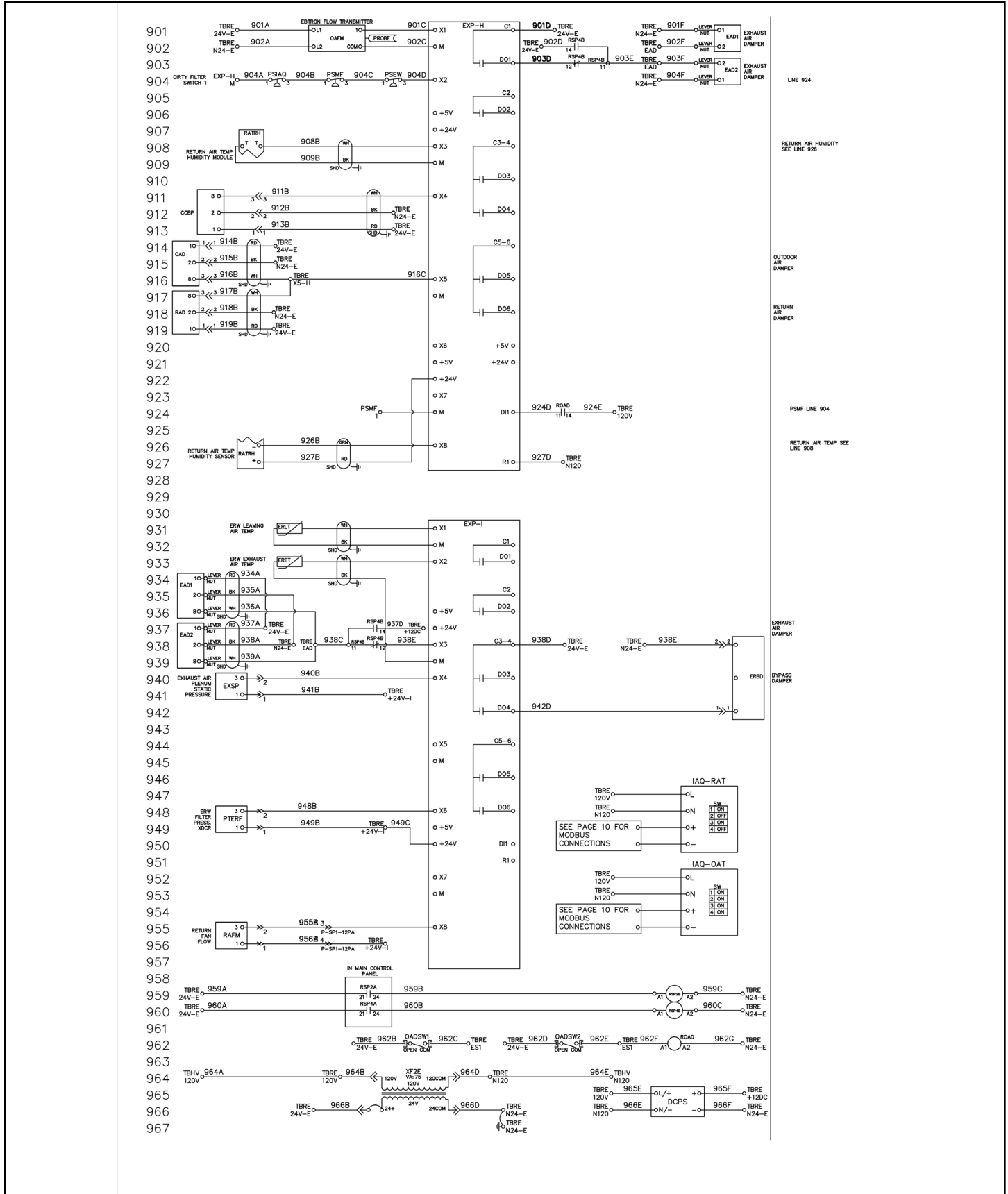
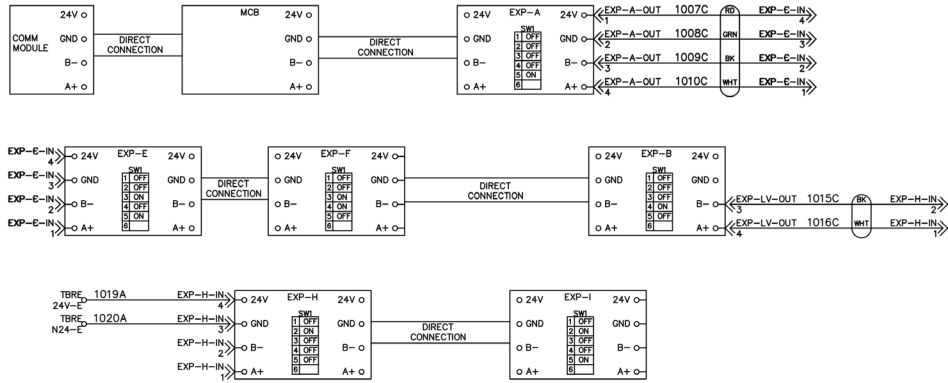
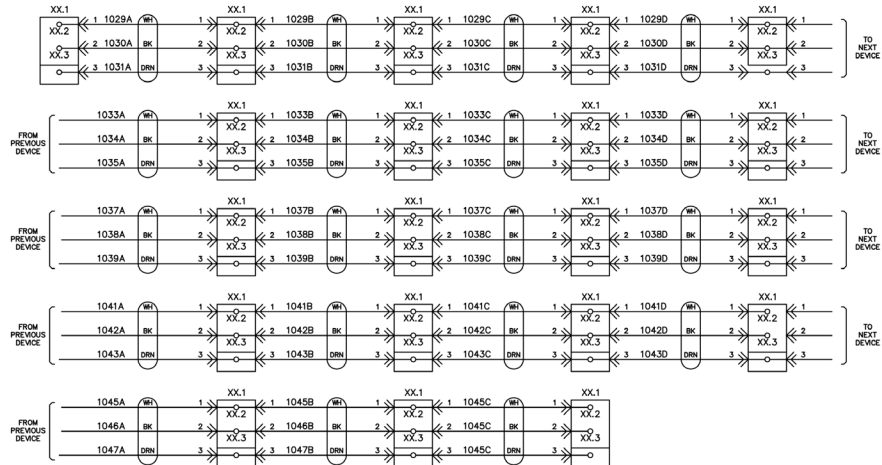


Figure 202: Typical Rebel Applied Wiring Diagram (continued)

1001 DIP SWITCHES: ON IS IN THE UP POSITION – THE  
 1002 LAST MODULE IN LINE MUST HAVE DIP SWITCH 6 IN  
 1003 THE ON POSITION  
 1004  
 1005  
 1006



1019 NOTE: SPLICE DRAINS TOGETHER BUT ONLY TERMINATE ON MCB



1060 MODBUS DEVICE ADDRESSES

1061

1062	XX.5 : XX.4	XX.5 : XX.4	XX.5 : XX.4	XX.5 : XX.4
1063	XX.5 : XX.4	XX.5 : XX.4	XX.5 : XX.4	XX.5 : XX.4
1064	XX.5 : XX.4	XX.5 : XX.4	XX.5 : XX.4	XX.5 : XX.4
1065	XX.5 : XX.4	XX.5 : XX.4	XX.5 : XX.4	XX.5 : XX.4
1066	XX.5 : XX.4	XX.5 : XX.4	XX.5 : XX.4	XX.5 : XX.4

1067

Figure 203: Typical Rebel Applied Wiring Diagram (continued)

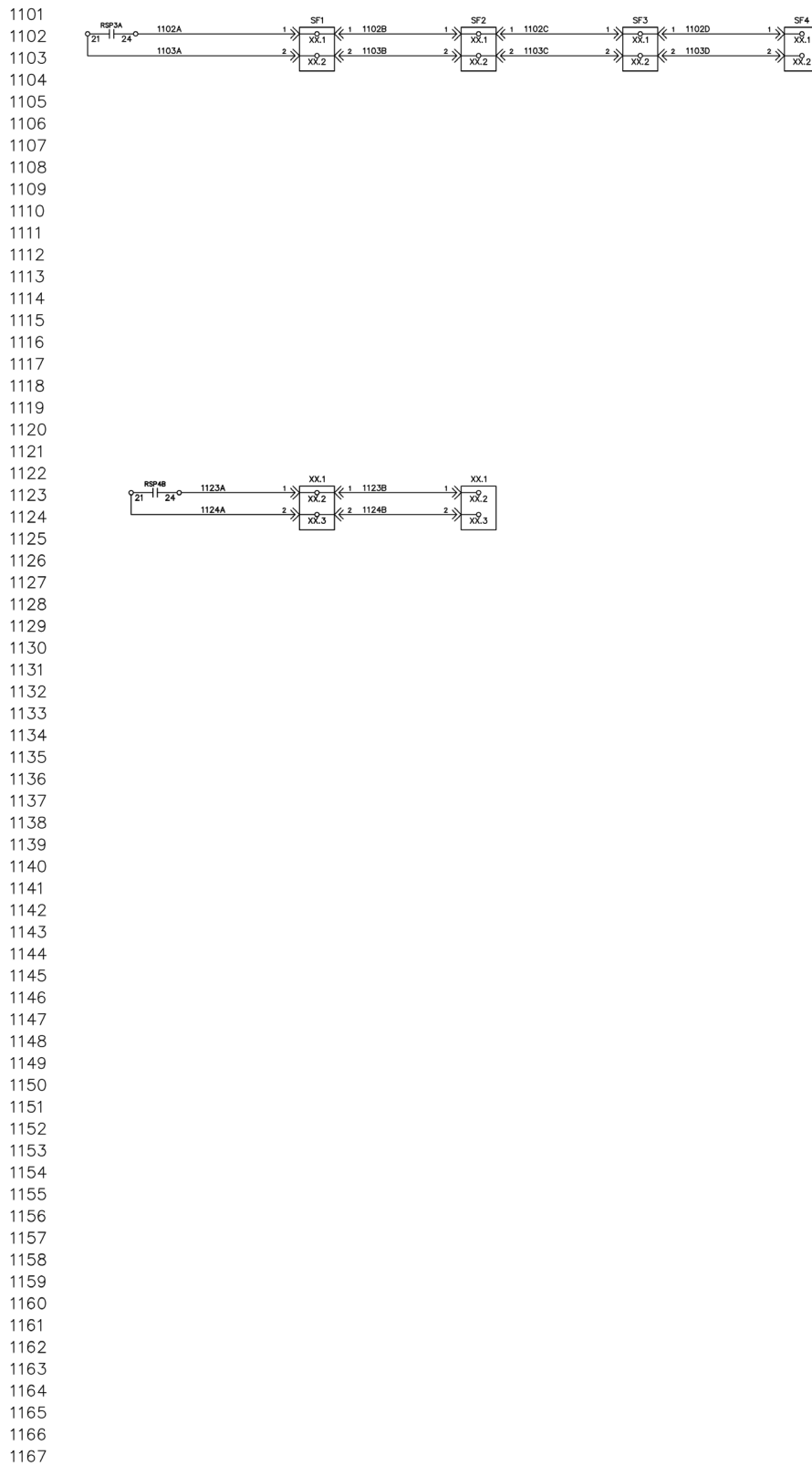


Figure 204: Typical Rebel Applied Wiring Diagram (continued)

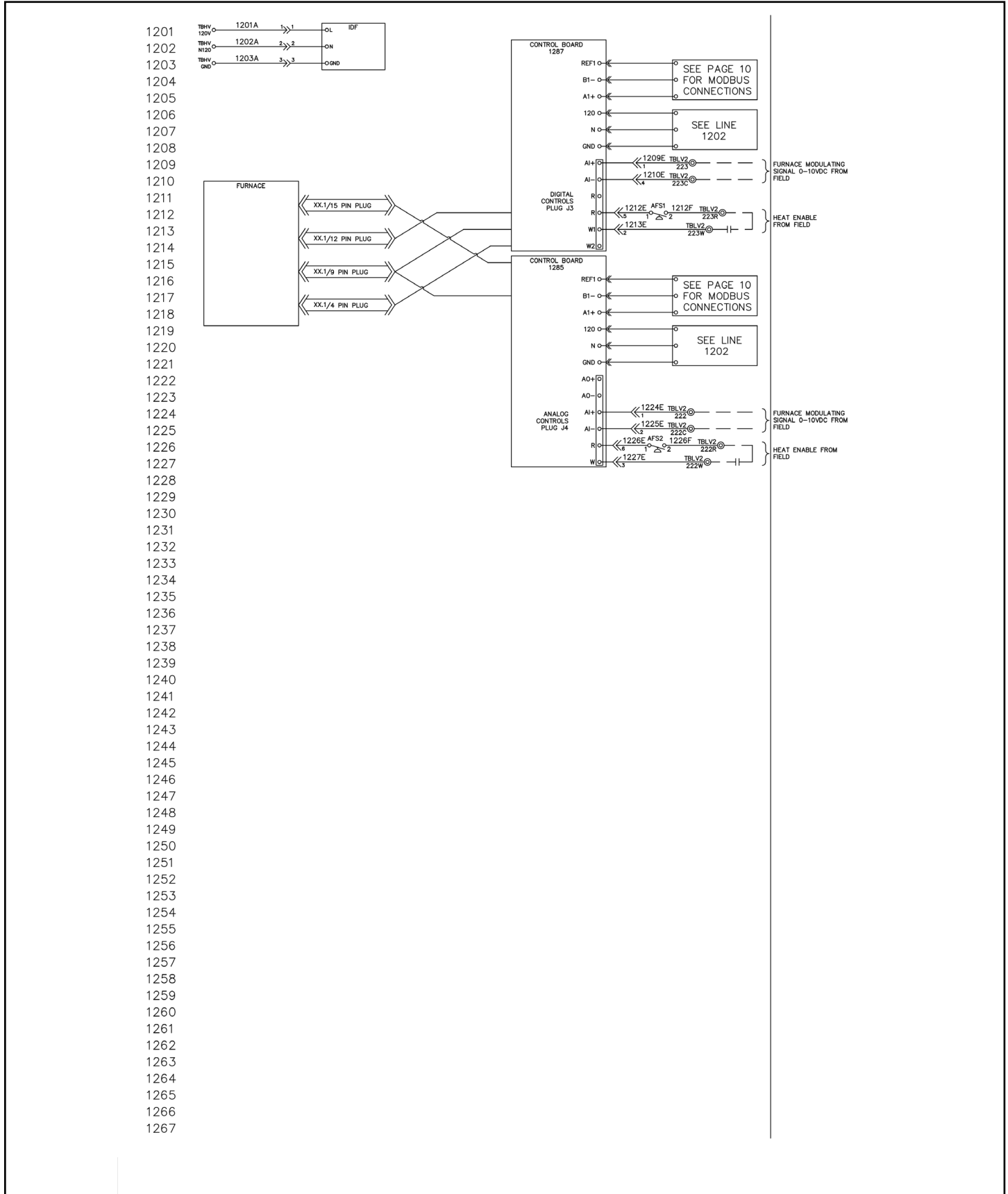


Figure 205: Typical Rebel Applied Wiring Diagram (continued)

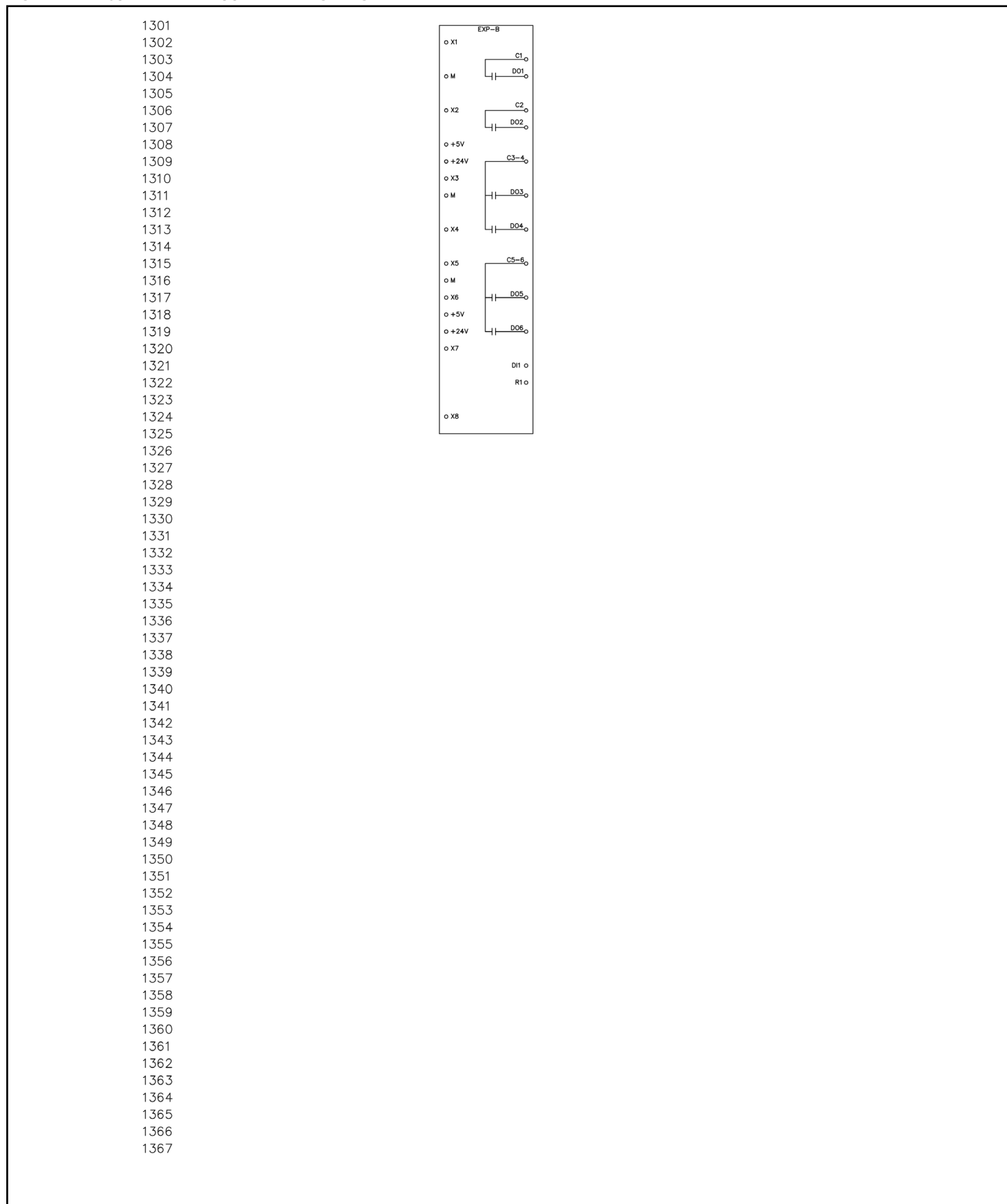
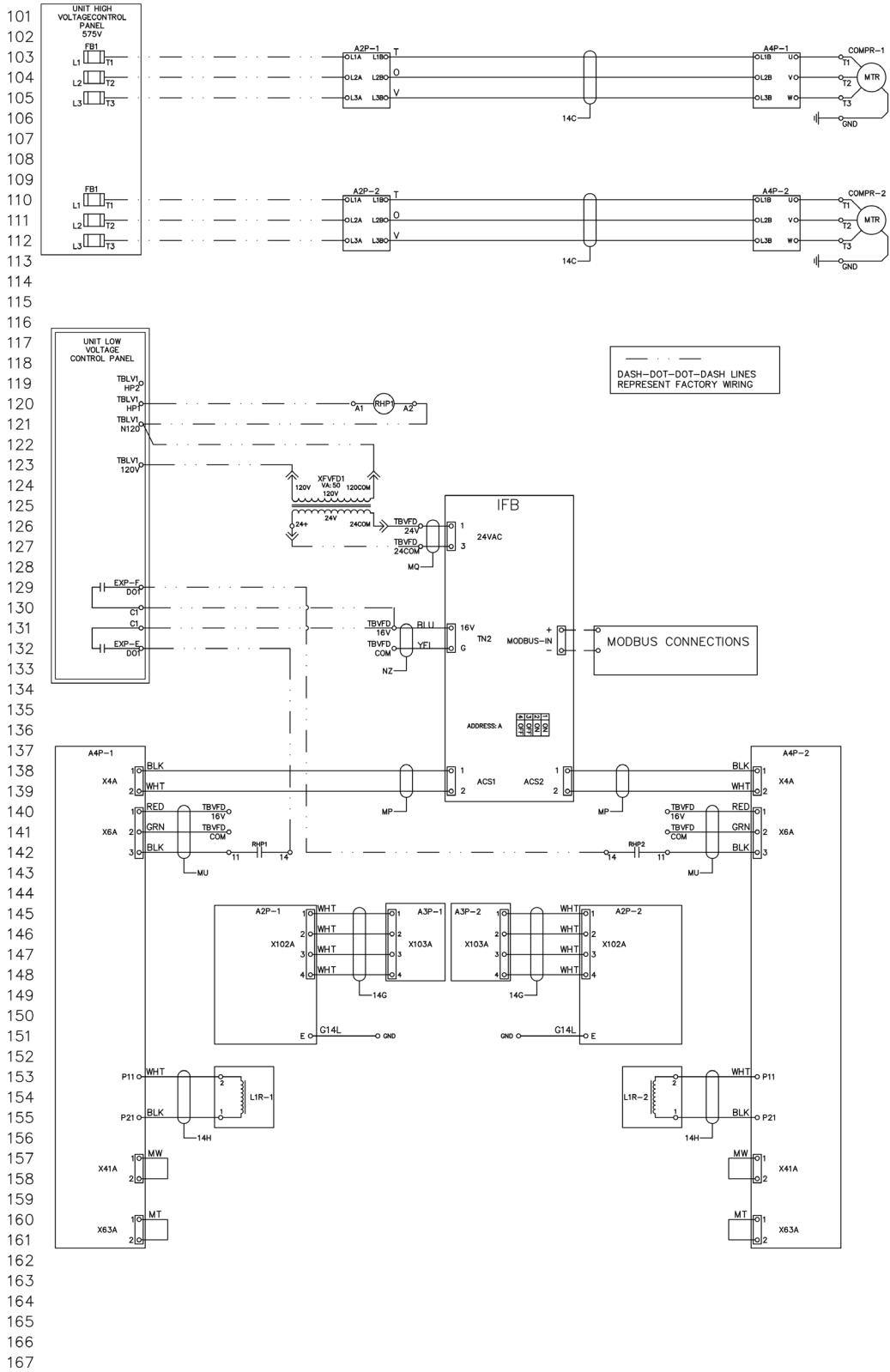


Figure 206: Typical Rebel Applied Wiring Diagram (continued)



## Planned Maintenance

Planned maintenance is the best way to avoid unnecessary expense and inconvenience. Have this system inspected at regular intervals by a qualified service technician. The required frequency of inspections depends upon the total operating time and the indoor and outdoor environmental conditions. Routine maintenance should cover the following items:

- Tighten all belts, wire connections, and setscrews.
- Clean the evaporator and condenser coils mechanically or with cold water, if necessary. Usually any fouling is only matted on the entering air face of the coil and can be removed by brushing.
- Check each circuit's refrigerant sightglass when the circuit is operating under steady-state, full load conditions. The sightglass should then be full and clear. If it is not, check for refrigerant leaks.

**NOTE:** A partially full sight glass is not uncommon at part load conditions.

- Check for proper superheat.
- Check for proper subcooling.
- Check for blockage of the condensate drain. Clean the condensate pan as needed.
- Check the power and control voltages.
- Check the running amperage of all motors.
- Check all operating temperatures and pressures.
- Check and adjust all temperature and pressure controls as needed.
- Check and adjust all damper linkages as needed.
- Check the operation of all safety controls.
- Check the condenser fans and tighten their setscrews.
- Lubricate the door latch mechanisms.

## Unit Storage

### Location

The Daikin Applied Rooftop Packaged System Unit is an outdoor unit. However, the schedule may dictate storage either on the ground or in its final position at the site. If the unit is stored on the ground, additional precautions should be taken as follows:

- Make sure that the unit is well supported along the length of the base rail.
- Make sure that the unit is level (no twists or uneven ground surface).
- Provide proper drainage around the unit to prevent flooding of the equipment.
- Provide adequate protection from vandalism, mechanical contact, etc. The condenser fins are particularly vulnerable to damage by even light contact with objects.
- Make sure all doors are securely closed.

- If isolation dampers are provided, verify that they are properly installed and fully closed to prevent the entry of animals and debris through the supply and return air openings.
- Units without isolation dampers should be fitted with covers over the supply and return air openings.

### Preparation

#### Supply (and Return) Fans

1. Turn the supply and return fan manual motor protectors (MMP) to the OFF position.
2. Once every two weeks, rotate the fan and motor shafts. Mark the shaft positions first to make sure they stop in a different position.
3. Depending on local climatic conditions, condensate may collect on components inside the unit. To prevent surface rust and discoloration, spray all bare metal parts with a rust preventive compound, and consider adding a desiccant inside of the cabinet and control panel. Pay close attention to fan shafts, bearings, and bearing supports.

#### Cabinet Sections

Once a month, open a door on each section and verify that no moisture or debris is accumulating in the unit.

#### Refrigeration circuits

The steps below are necessary only if the unit has been started.

1. Turn the compressor manual motor protectors (MMP) to the OFF position.
2. Close the discharge and liquid line refrigerant service valves on each circuit.
3. Tag the valves as a warning for the technician who restarts the units.

### Restart

After extended storage, perform a complete start up. Inevitable accumulations of dirt, insect nests, etc., can contribute to problems if not cleaned out thoroughly prior to start up. In addition, thermal cycling tends to loosen mechanical and electrical connections. Following the start-up procedure helps discover these and other issues that may have developed during the storage interval.

# Daikin Applied Electric Heater Modules

**⚠ DANGER**  
 Hazardous electrical situation which will result in death or serious injury if not avoided. LOCKOUT/TAGOUT all power sources prior to servicing the unit. More than one disconnect may be required to de-energize the unit.

**⚠ WARNING**  
 Electrical shock can cause severe personal injury or death. Control panel must be serviced by trained and qualified technicians.

**⚠ WARNING**  
 Electrical shock can cause severe personal injury or death. All protective deadfront panels must be reinstalled and secured when power wiring is complete.

**⚠ WARNING**  
 Installation and maintenance must be performed only by qualified personnel who are trained and experienced with this type of equipment and familiar with local codes and regulations.

**⚠ WARNING**  
 Improper installation, adjustment, alteration, service, or maintenance can cause personal injury or death. Read carefully and understand this installation and maintenance manual thoroughly before installing or servicing this equipment.

## Electric Heater General Information

The 23rd through the 26th digits in the DPSA rooftop model number will be used to define the DPSA Main electric heater when the unit is furnished with a factory installed electric heater.

Example: DPSA - - - - - EEDS would be a 40kW electric heater with modulating control.

The DPSA electric heaters are available with stage or modulating heat output. The heaters are designed for outdoor non-residential installations only.

If unit is equipped with energy recovery wheel (ERW), the 43rd digit in the DPSA rooftop model number will be used to define the ERW pre heater.

Example: DPSA - - - - - C would be a 10kW electric heater with SCR.

The DPSA ERW electric heaters are only available with modulating heat output. The heaters are designed for outdoor non-residential installations only.

The electric heat design consists of a heating coil, DDC staging control, and all operational safeties. The safety switches include high-limit temperature switches and individual coil fusing.

The high limit temperature switches are configured as automatic resetting for the primary protection switch(es) and manual resetting for the backup protection switch(es). See [Table 33](#) for main electric heat or [Table 34](#) for ERW electric heater. The primary protection switch(es) open the control circuit and shuts

the heater down when the temperature reaches the high limit set point; the circuit closes again when the temperature falls below dead band and then allows the heater to run. The backup protection switch(es) open the control circuit and shuts the heater down when the temperature exceeds the set point. The switch(es) requires manual resetting to resume electric heat operation. The Temperature High Limit backup switches may be found by de-energizing the unit, removing the dead-front, and locating the switches as per [Figure 208 on page 129](#).

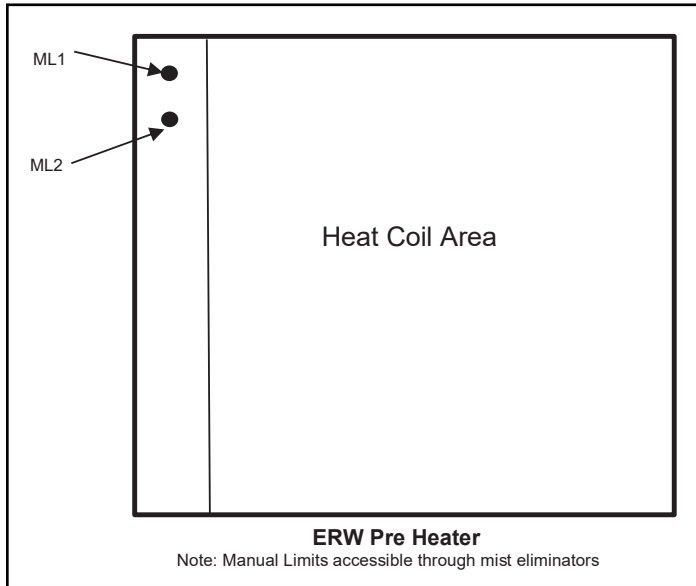
**Table 33: Main Electric Heat Switch Identification**

Size	Voltage	kW	Amps	High Temp Limit Primary Switch (Qty)	High Temp Limit Backup Switch (Qty)
1	208	10 – 15	28 – 42	2	1
	240	10 – 15	24 – 36	2	1
	480	10 – 15	12 – 18	2	1
	600	10 – 15	10 – 15	2	1
2	208	30 – 105	83 – 290	2	1
	240	20 – 139	48 – 335	2	1
	480	20 – 140	24 – 168	2	1
	600	25 – 125	24 – 120	2	1
3	208	120	332	2	2
	240	159	383	2	2
	480	159 – 239	192 – 288	2	2
	600	149 – 249	144 – 240	2	2
4	208	30 – 120	83 – 332	1	2
	240	40 – 159	96 – 383	1	2
	480	40 – 319	48 – 384	1	2
	600	50 – 250	48 – 240	1	2
5	208	75 – 120	208 – 332	1	2
	240	100 – 160	240 – 383	1	2
	480	100 – 399	121 – 480	1	2
	600	75 – 300	73 – 289	1	2

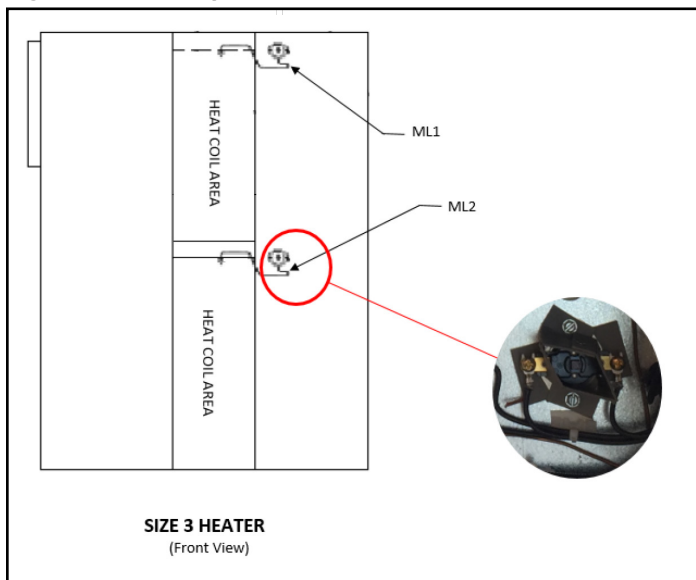
**Table 34: ERW Electric Heat Switch Identification**

Voltage	kW	Amps	High Temperature Limit Primary Switch (Qty)	High Temperature Limit Backup Switch (Qty)
208	10-45	28 -126	3	2
240	10-60	25-145	3	2
480	10-100	13-121	3	2
600	10-100	10-97	3	2

**Figure 207: Backup Manual Switch Location**



**Figure 208: Backup Manual Switch Location**



**NOTE:** It is not recommended to use the auxiliary electric heat as a reheat source for space control.

## Electric Heat Installation

The DPSA main electric heater and ERW pre-heater are factory installed and wired. Field supplied power wiring to be in accordance with NEC and any existing local codes by trained qualified installation and service personnel.

## Start-up

### Manual Mode

1. Turn main power on to the cabinet and electric preheat.
2. Set the process supply fan to deliver at least the minimum required air flow via MicroTech. See cabinet electric heat data plate for flow rate.
3. Enable electric heater control via MicroTech.
4. Input temperature control value via MicroTech and observe discharge air temperature is responding as expected.

### Automatic Mode

1. Turn power ON to the cabinet and electric preheat.
2. Set MicroTech to desired control parameters.

## Operation

To operate electric heater, make sure all associated control equipment is on, energize main supply disconnect, and set controlling thermostat above ambient temperature. This heater is equipped with automatic and manual reset temperature limiting controls. If it fails to operate, make sure manual resets are operative by pushing reset buttons as discussed above.

## Maintenance

Check all electrical connections, including field and factory-made connections, for tightness at least once per year or operating season. Any filters in the airstream must be kept clean so that adequate airflow is maintained.

**Table 35: Troubleshooting-Main Electric Heat or ERW Electric Heat**

Problem	Cause	Remedy
No Heat	Main power OFF	Turn main power disconnect switch on
	Fan not activated	Check to see if fan unit is on and if auxiliary contact on fan motor starter is closed. Check all field wiring for continuity or possible short circuits. Check wiring diagram on inside of cover of heater or panel boards for interlocks and remote control equipment to make sure it is all working
	Manual thermal cutout tripped	Check for obstructions to airflow through the heater. (Outdoor Air Damper Open, Mist Eliminators Clean, Filters Clean, etc) Check that heater has at least the minimum amount of airflow Check all manual thermal cutout(s) reset button(s) - reset as required Check all fuses - replace as required
	Automatic thermal cutout tripped	Check for obstructions to airflow through the heater. (Outdoor Air Damper Open, Mist Eliminators Clean, Filters Clean, etc) Check that heater has at least the minimum amount of airflow Check all manual thermal cutout(s) reset button(s) - reset as required Check all fuses - replace as required
	Fuses blown	Check for obstructions to airflow through the heater. (Outdoor Air Damper Open, Mist Eliminators Clean, Filters Clean, etc) Check that heater has at least the minimum amount of airflow Check all manual thermal cutout(s) reset button(s) - reset as required Check all fuses - replace as required
Low Output	Heating element burned out	Check for burned out elements by disconnecting power wiring to the elements and connecting a reliable ohmmeter to the element terminals Element resistance (R) should be: $R = E^2 / (1.06 \times W) \pm 5\%$ Where E = voltage across element; W = Number of kW x 1000/Number of elements
	Low line voltage	Check nameplate voltage is equal to line voltage
	Cycling on automatic thermal cutout	Check for obstructions to airflow through the heater. (Outdoor Air Damper Open, Mist Eliminators Clean, Filters Clean, etc) Check that heater has at least the minimum amount of airflow Check all manual thermal cutout(s) reset button(s) - reset as required Check all fuses - replace as required
	Fuses blown	Check for obstructions to airflow through the heater. (Outdoor Air Damper Open, Mist Eliminators Clean, Filters Clean, etc) Check that heater has at least the minimum amount of airflow Check all manual thermal cutout(s) reset button(s) - reset as required Check all fuses - replace as required
Overheating	Control system	Check to see if fan is ON Check all field wiring for continuity or possible short circuits Check wiring diagram to make sure interlocks and remote control equipment are working
	Not enough airflow	Check for obstructions to airflow through the heater. (Outdoor Air Damper Open, Mist Eliminators Clean, Filters Clean, etc) Check that heater has at least the minimum amount of airflow Check all manual thermal cutout(s) reset button(s) - reset as required Check all fuses - replace as required
	Uneven or partially blocked airflow	Check for obstructions to airflow through the heater. (Outdoor Air Damper Open, Mist Eliminators Clean, Filters Clean, etc) Check that heater has at least the minimum amount of airflow Check all manual thermal cutout(s) reset button(s) - reset as required Check all fuses - replace as required
	High line voltage	Check nameplate voltage is equal to line voltage
Terminals Overheating	Loose connections	Check for obvious signs of terminal and wiring overheating Tighten and repair as required All terminals should be checked and tightened once a year or at the start of every heating season
	Improperly sized wire	All incoming wiring should be sized in accordance with NEC Article 424
	High voltage	Check nameplate voltage is equal to line voltage
Contactor Hum or Chatter	Low control voltage	Check nameplate voltage is equal to line voltage Check control voltage, it should not be less than 90% of the contactor coil voltage
	Dirt on armature of holding coil	Clean contactor armature with low air pressure and a stiff brush
	Defective contactor	Replace contactor

## Electric Heater Step Controller

The S5 Series step controller is a microcomputer-based stage controller designed to provide low cost precise control for multi-stage applications. Common applications are HVAC duct heaters, industrial process air heaters and circulation heaters.

- Low voltage 24 VAC microcomputer-based stage controller
- Capable of controlling 24 VAC loads
- 5 stage controller with a pulsed 10 VDC vernier stage rated at 100 mA.
- Up to 10 stages of control when using a slave unit

### Stage Sequencing

The S5 Series step controller operates in a linear control mode. The first stage ON will be the last stage OFF (LIFO). For example: 1,2,3,4,5 ON then 5,4,3,2,1 OFF.

### Vernier Operation

The S5 Series step controller supports a 10 VDC pulsed vernier stage to operate a slave SCR/SSR controller. This will result in more precise control than is otherwise possible with a standard on-off step controller. The slave SCR/SSR power controller provides proportional control (0-100% load) between the switching of the step controller stages:

Figure 209: Sequence Control without Vernier

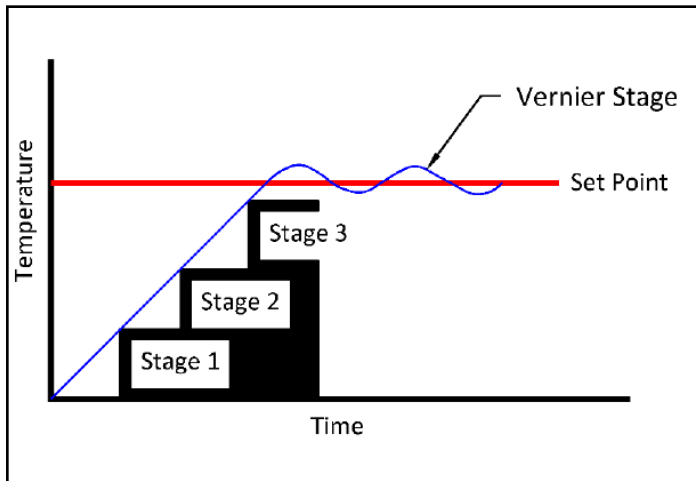
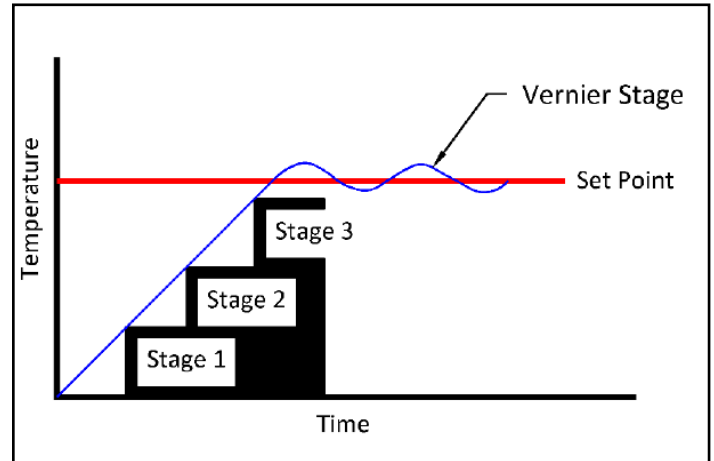


Figure 210: Sequence Control without Vernier



# Electric Heat Step Controller Set-Up

Figure 211: Step Controller Set-Up Instructions

**OPERATIONAL SETTINGS:**

SLAVE	<input type="checkbox"/>	MASTER
4-20 mA	<input type="checkbox"/>	0-10VDC
OFF	<input type="checkbox"/>	TSTAT
OFF	<input type="checkbox"/>	VERN
TEST	<input type="checkbox"/>	CONTROL
OFF	<input type="checkbox"/>	5
OFF	<input type="checkbox"/>	10
OFF	<input type="checkbox"/>	20
SW1 OFF	<input type="checkbox"/>	40



**CAUTION:**

- Disconnect all power before changing any controller settings.
- For a master/slave application:  
 Connect the Vernier output to the master step controller.  
 All settings except switch 1 (ie. Master / Slave) on the slave controller are disabled and control is determined by the settings on the master.  
 Wire the control signal to the master unit only.

Switch	OFF	ON	Description
1	Slave	Master	Set control to operate as a slave or a master. All switches must be in the 'OFF' position for slave operation.
2	4-20 mA	0-10 VDC	Set control for operation with a 4-20 mA or a 0-10 VDC input signal.
3	Off	TSTAT	Set switch to 'TSTAT' when using a 3-wire thermostat with a 0-10VDC input signal.
4	OFF	VERN	Set to 'VERN' when utilizing the vernier control functionality of terminals S1(+) & S2(-).
5	TEST	CONTROL	Set control functionality to test mode or control mode. See section titled 'FUNCTIONAL TEST DESCRIPTION' for description of test sequence.

**DELAY SETTINGS (Seconds):**

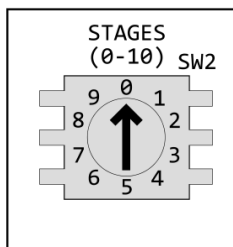
Seconds	Switches 6 - 9			
	5	10	20	40
1	Off	Off	Off	Off
5	On	Off	Off	Off
10	Off	On	Off	Off
15	On	On	Off	Off
20	Off	Off	On	Off
25	On	Off	On	Off
30	Off	On	On	Off
35	On	Off	On	Off
40	Off	Off	Off	On
45	On	Off	Off	On
50	Off	On	Off	On
55	On	On	Off	On
60	Off	Off	On	On
65	On	Off	On	On
70	Off	On	On	On
75	On	On	On	On

**INPUT SIGNAL TOLERANCES:**

Nominal	Low Range Limit	High Range Limit
4-20 mA	3	21.0
0-10 VDC	0	10.5
TStat VDC	0	10.5

Input signals above or below the Range Limits will result in an error indication. The controller will continue to operate, but an error light will indicate the out of range condition. See the section 'TROUBLESHOOTING' for error indication light definitions.  
 Tolerance of +10% / -5% on range limit indications.

**STAGE CONFIGURATION:**



The STAGE dial is used to configure the proper number of stages. Set the stages to a value between 1 and 10 on the master controller.  
 When a slave controller is used, always set the stages on the master controller to a value greater than 5.

## Step Controller Troubleshooting

Figure 212: Step Controller Troubleshooting Instructions

### FUNCTIONAL TEST DESCRIPTION:



#### CAUTION:

- Disconnect all power before changing any controller settings.

The functional test mode can be used to verify board operation, stage settings and input signal. This mode will bypass both the inter-stage delay settings and input signal in order to sequence the stages according to the current status of the STAGE settings. The test sequence will also validate the input signal.

The board is configured for the functional test mode by setting switch 5 to 'TEST'. When the board is powered on in the functional test mode, the following sequence of events will take place:

1. The following LEDs will illuminate on power up and remain on during the cycling up and down of the stages:

LED			Master Unit	Slave Unit
Description	Number	Color		
Power	LED 1	Red	On	On
Error	LED 2	Yellow	On	Off
Run	LED 3	Green	On	On
Fault	LED 4	Yellow	On	Off
DC Power	LED 10	Red	On	On
Vernier	LED 11	Green	On	Off
Slave	LED 12	Green	On	On

2. The stage LED lights will cycle on and then off in a linear fashion (first on, last off) according the number of stages currently set. Both the inter-stage delay settings and input signal are bypassed during this test.
3. After the stage cycling is complete, the controller will perform a test to verify the input signal. All lights except the DC Power (LED 10) will turn off and one of the following lights will blink to conclude the functional test:

LED			Description of input test result if LED is illuminated
Description	Number	Color	
Power	LED 1	Red	Reversed polarity (mA or VDC)
Error	LED 2	Yellow	No input signal detected or signal detected is out of range *
Run	LED 3	Green	No issues. Valid input signal detected.

\* Tolerance of +10% / -5% on range limit indications.

4. After test is complete, power down controller and set switch 5 back to 'Control'. The controller is ready to put into service. If the light sequence shown is not as expected based on the current setup parameters, please verify settings and contact factory for assistance.



Figure 214: 100kW – 250kW (Step Control)

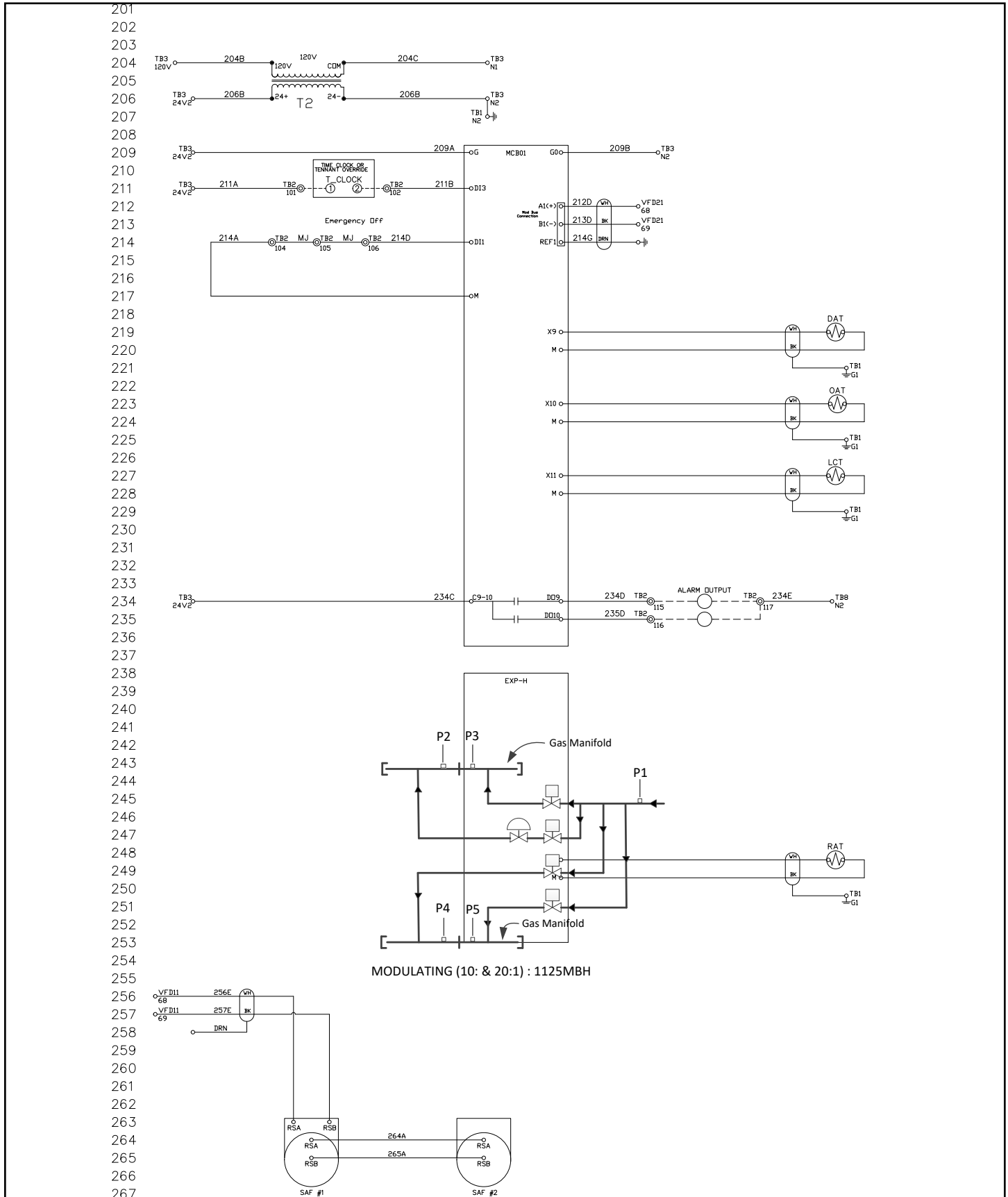


Figure 215: 10kW – 50kW (Full SCR Control)

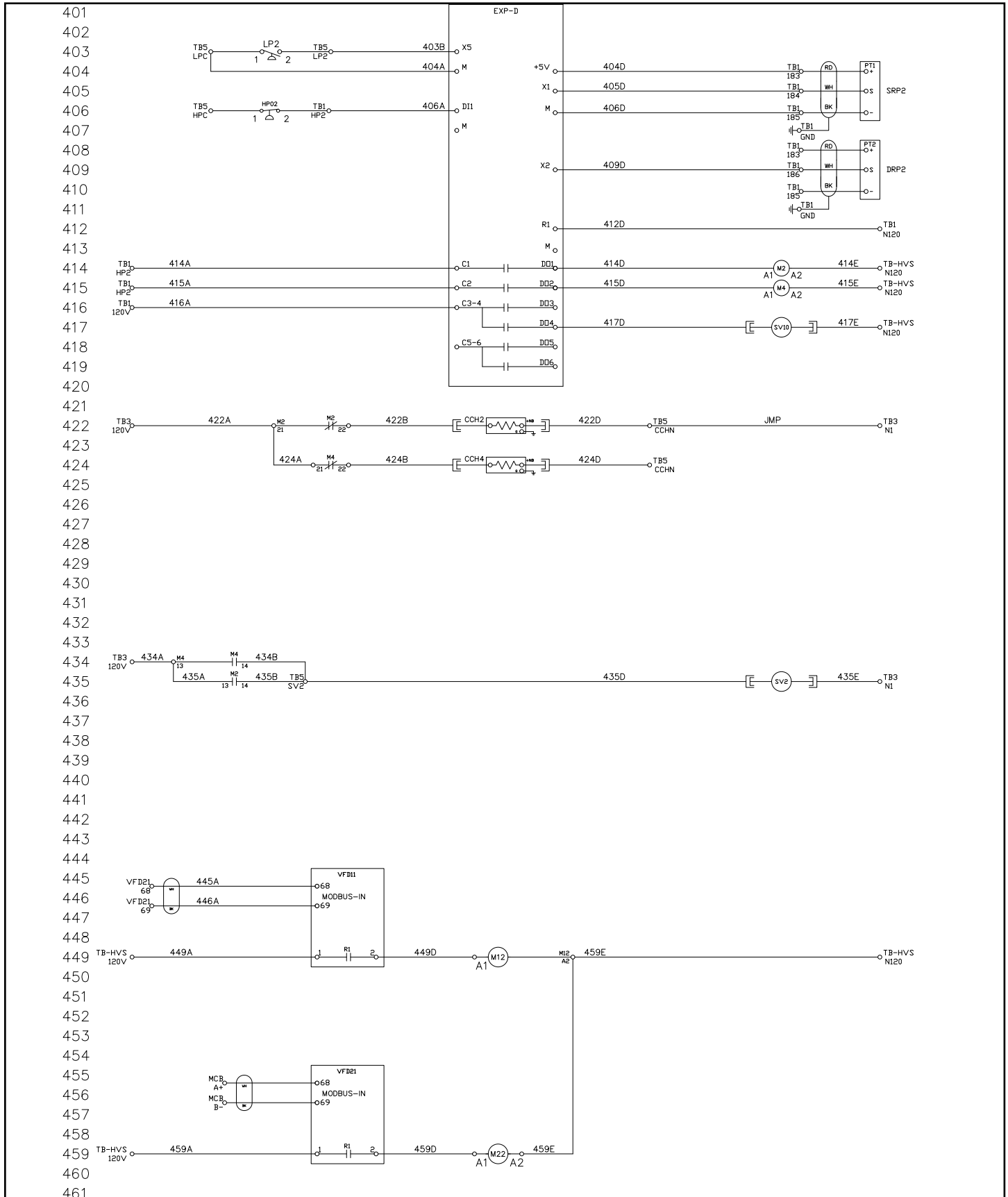
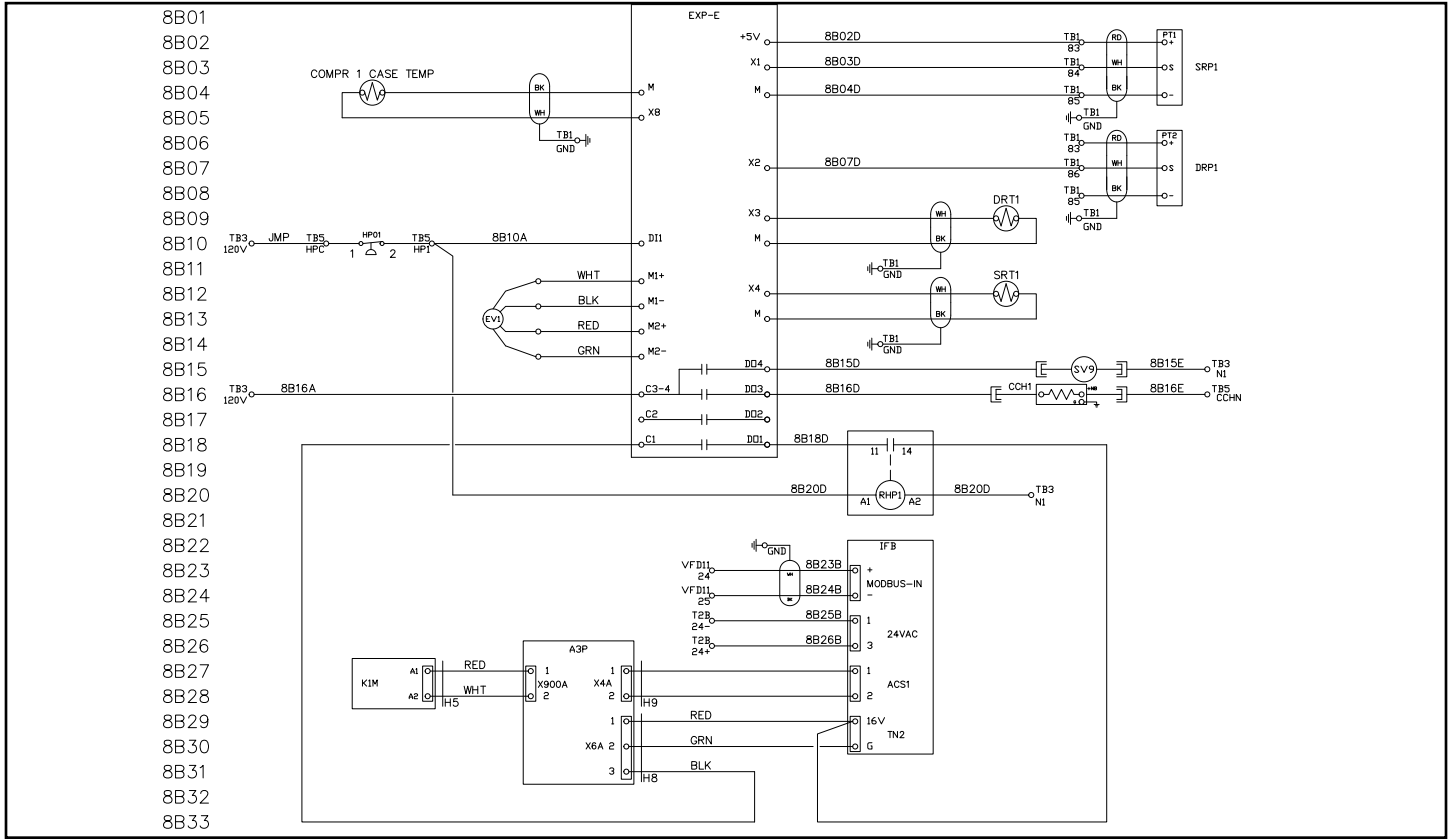
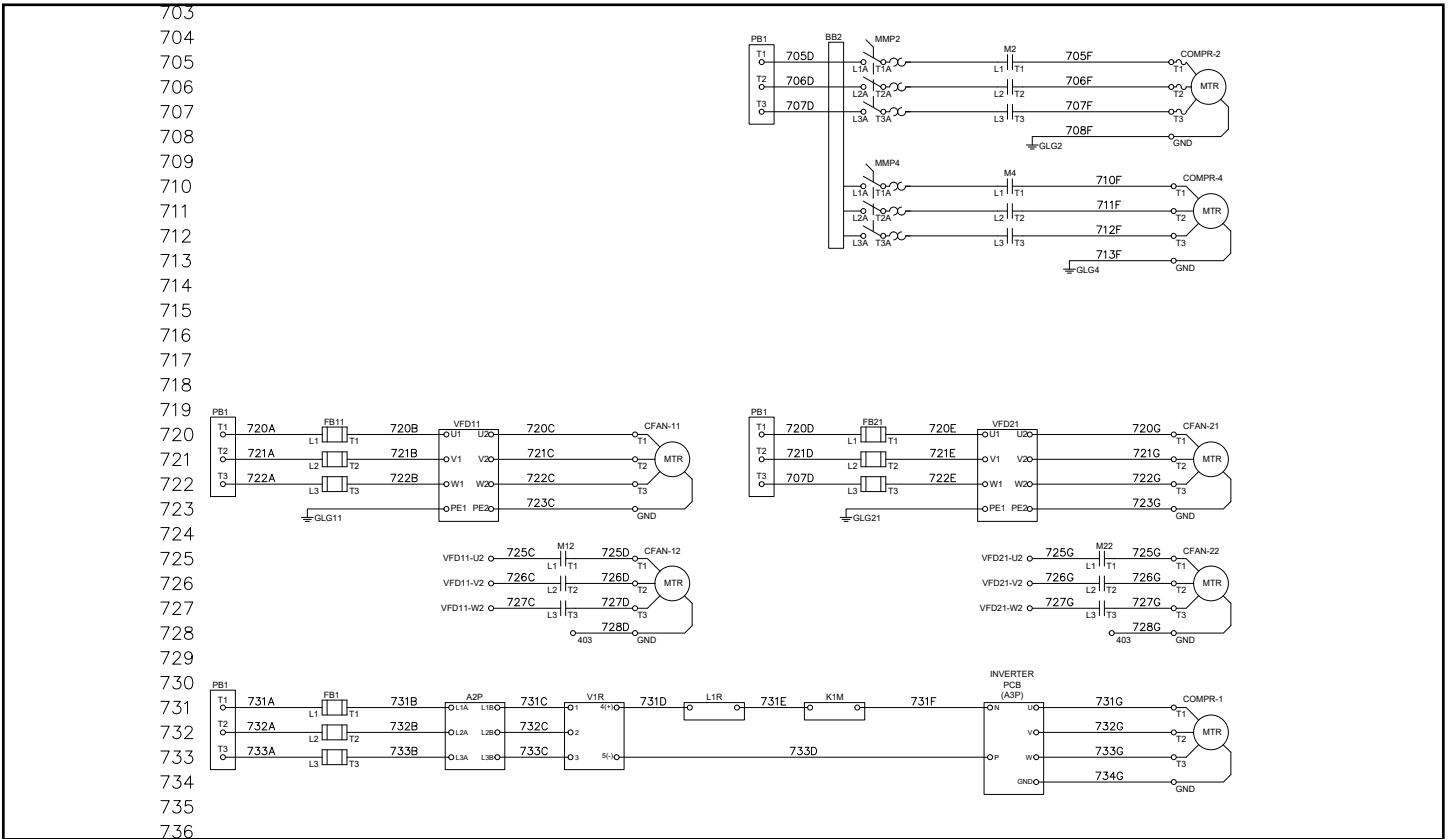


Figure 216: 40kW – 250kW (SCR Vernier Control)



# Tubular Gas Heater

## Packaged Gas Heater Module

ANSI Z83.8/CSA 2.6

### WARNING

#### Risque D'Incendie ou D'Explosion

Le non respect des mises en garde pourrait entraîner des blessures graves, la mort, ou des pertes matérielles. Prendre soin de lire et de comprendre les instructions d'installation, de fonctionnement et d'entretien contenues dans ce guide. Une installation, un réglage, une modification, une réparation ou un entretien inapproprié peut entraîner des blessures graves, la mort, ou des pertes matérielles.

- Ne pas entreposer ni utiliser d'essence ou autre vapeurs ou liquides inflammables à proximité de cet appareil ou de tout autre appareil.
- **QUE FAIRE SI VOUS SENTEZ UNE ODEUR DE GAZ**
- Ne tentez pas d'allumer un appareil.
- Ne touchez pas à un interrupteur; n'utilisez pas de téléphone dans l'édifice ou vous trouvez.
- Sortez de l'édifice immédiatement.
- Appelez immédiatement le fournisseur de gaz à partir d'un téléphone à l'extérieur de l'édifice. Suivez les instructions du fournisseur de gaz.
- Si vous ne pouvez joindre le fournisseur de gaz, appelez les pompiers.
  - L'installation et les réparations doivent être confiées à un installateur qualifié ou au fournisseur de gaz.

### WARNING

#### Fire or Explosion Hazard

LOCKOUT/TAGOUT all power sources prior to installing the gas furnace. Failure to follow warnings exactly could result in serious injury, death, or property damage. Be sure to read and understand the installation, operation, and service instructions within this manual. Improper installation, adjustments, alterations, service, or maintenance can cause serious injury, death, or property damage.

- Do not store or use gasoline or other flammable vapors or liquids in the vicinity of this appliance.
- **What to do if you smell gas**
- Do not try to light any product that is fueled by or contains an open flame.
- Do not touch any electrical switch.
- Do not use any telephone in the building.
- Leave the building immediately.
- Immediately call the gas supplier from a remote telephone and follow the gas supplier's instructions.
- If you cannot reach the gas supplier, call the local fire department or 911.
  - Installation and service must be performed by a qualified installer, service agency, or gas supplier.

### NOTICE

HM series modules are a recognized furnace component design certified by Intertek® Testing Services (ETL). For outdoor installation only. Suitable for both indoor and outdoor installation. Must be installed downstream of supply air fans.

### WARNING

Ensure gas furnace flues do not discharge near the fresh air intake of any other equipment or building opening.

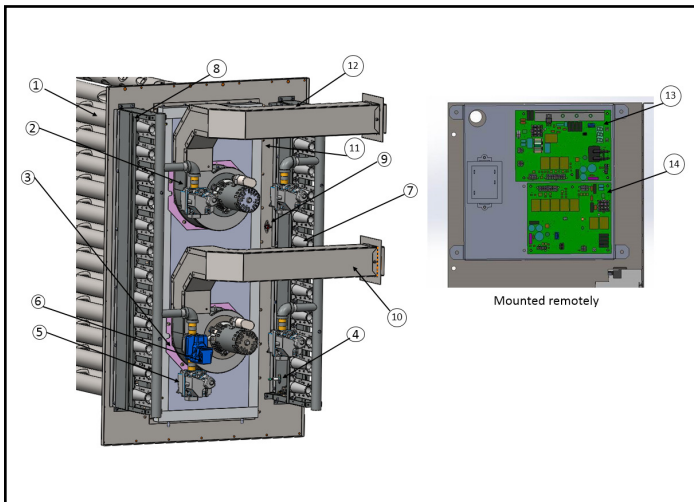
### NOTICE

The unit should be installed so that the fresh air has unimpeded access to the louvered furnace fresh air intake.

### WARNING

Unit equipped with gas heating must not be operated in an atmosphere contaminated with chemicals which will corrode the unit, such as halogenated hydrocarbons, chlorine, cleaning solvents, refrigerants, swimming pool exhaust, etc. Exposure to these compounds may cause severe damage to the gas furnace and result in improper or dangerous operation. Operation of the gas furnace in such a contaminated atmosphere and will void all warranty coverage by the manufacturer. Questions regarding specific contaminants should be referred to your local gas utility.

**Figure 217: Typical Gas Heat Section Assembly and Component Identification for Double Flue Furnaces (10:1 1125 MBH model shown)**

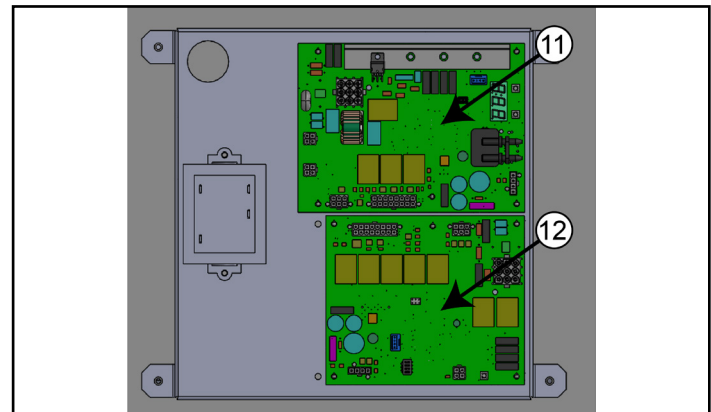
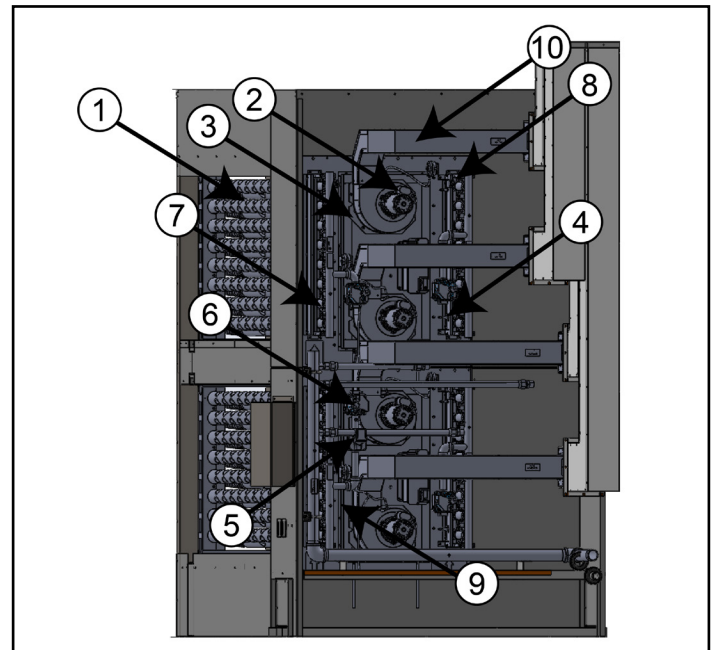


**Table 36: Item Descriptions for Figure 217**

Item	Description	Item	Description
1	Heat exchanger	10	Flue
2	Inducer blower	11	Pressure switch
3	Inducer orifice plate	12	Flame sensor
4	Igniter	13	VB 1285 modulating control board
5	Gas safety valve	14	VB1287 staged control board
6	Modulating valve	15	Transformer
7	In-shot burner	16	High Temp limit interlock relay
8	Rollout switch	17	On/off solenoid valve (not pictured)*
9	High limit switch		

\*On/off solenoid valve only present in 800 MBH 10:1 (NG) or 6:1 (LP) furnaces.

**Figure 218: Typical Gas Heat Section Assembly and Component Identification for Four Flue Furnaces (10:1 1500 MBH model shown)**



**Table 37: Item Descriptions for Figure 218**

Item	Description	Item	Description
1	Heat exchanger	8	Rollout switch
2	Inducer blower		Pressure switch
3	Inducer orifice plate		Flame sensor
4	Igniter	9	High limit switch*
5	Gas safety valve	10	Flue
6	Modulating valve	11	VB 1285 modulating control board
7	In-shot burner	12	VB1287 staged control board

\*Location only; not visible in image.

## Unit Location and Clearances

While the cabinet location is normally selected by the architect, builder, or installer, before installation ensure that the following requirements are met before final installation:

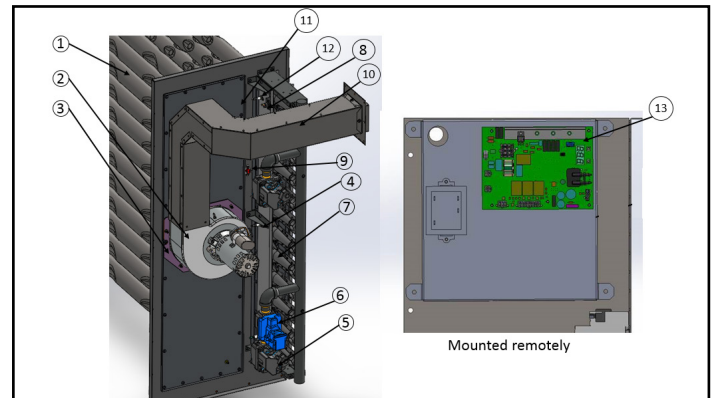
1. Do not install unit where it may be exposed to potentially explosive or flammable vapors.
2. Do not install unit in areas where corrosive vapors (such as chlorinated, halogenated, or acidic) are present in the atmosphere or can be mixed with combustion air entering furnace.
3. Cabinet location must provide access to all doors and panels and allow adjustment and service of the furnace.
4. Cabinet location must provide an adequate, unimpeded supply of fresh air for combustion.
5. Flue discharge should be at least 120 in. away from any opening or other equipment through which combustion products could enter the building.
6. Clearance from combustibles to be no less than as listed below:
  - a. Furnace access side:  
18 in. (914 mm)
  - b. All other sides:  
6 in. (152 mm)
  - c. Flue to any combustible surface:  
18 in. (914 mm)

Do not use this package heater if any part has been under water. Immediately call a qualified service technician to inspect the heater and any gas control which has been under water.

If the 23rd digit in the model number is a “G”, the rooftop unit was furnished with a factory installed natural gas furnace (Example: DPSA.....GG3KE). If the 23rd digit in the model number is a “P”, the rooftop unit was furnished with a factory installed propane furnace. The Rebel Applied commercial rooftop units are available in a variety of furnace capacity and turndown configurations. Reference the DPSA Gas Furnace Capacity Data section below for configuration-specific information. DPSA packaged gas heat rooftop units are designed for outdoor non-residential installations only. Furnaces to be supplied configured for natural gas OR LP only.

DPSA gas heat furnaces consist of a 439 stainless steel tubular heat exchanger, in-shot burner manifold with gas valve, induced combustion blower, gas heat DDC control module, and all operational safeties. The safety switches include a high-limit temperature switch, a combustion blower proof of airflow, and the flame roll-out switch (see [Figure 219](#) and [Figure 218](#)).

**Figure 219: Typical Gas Heat Section Assembly and Component Identification for Single Flue Furnaces (10:1 600 MBH model shown)**



**Table 38: Item Descriptions for Figure 219**

Item	Description	Item	Description
1	Heat exchanger	8	Rollout switch
2	Inducer blower	9	High limit switch
3	Inducer orifice plate	10	Flue
4	Igniter	11	Pressure switch
5	Gas safety valve	12	Flame sensor
6	Modulating valve	13	Control board
7	In-shot burner	14	Transformer

## Ventilation and Flue Pipe Requirements

### CAUTION

Prevent snow levels from blocking airflow into the furnace vestibule and combustion air inlet. Ensure snow does not accumulate and interfere with the operation of electronics within the vestibule.

### WARNING

Connect this unit only to gas supplied by a commercial utility. This furnace must be installed by an experienced professional installation company that employs fully trained and experienced technicians. Failure to connect gas lines to proper connection points may result in injury, death, and property damage. Install the gas piping in accordance with local codes and regulations of the installing utility company. In the absence of local codes, follow the National Fuel Gas Code, ANSI Z223.1/NFPA 54, or the CSA B149.1, Natural Gas and Propane Installation Code — latest edition.

### CAUTION

Sharp edges on sheet metal, fasteners, clips and similar items may cause personal injury. Exercise caution when installing or servicing the unit and wear appropriate personal protective equipment (PPE), such as eye protection, gloves, protective clothing, footwear, etc.

### DANGER

Keep hands and tools away to prevent electrical shock. Failure to adhere to this warning can result in serious injury or death. LOCKOUT/TAGOUT all power sources prior to starting the spark ignitor and ignition controller.

### WARNING

#### Fire or Explosion Hazard

Failure to follow warnings exactly could result in serious injury, death, or property damage. Be sure to read and understand the installation, operation, and service instructions within this manual. Improper installation, adjustments, alterations, service, or maintenance can cause serious injury, death, or property damage.

- Do not store or use gasoline or other flammable vapors or liquids in the vicinity of this appliance
- **What to do if you smell gas**
- Do not try to light any product that is fueled by or contains an open flame
- Do not touch any electrical switch
- Do not use any telephone in the building
- Leave the building immediately
- Immediately call the gas supplier from a remote telephone and follow the gas supplier's instructions
- If you cannot reach the gas supplier, call the local fire department or 911
  - Installation and service must be performed by a qualified installer, service agency, or gas supplier

### WARNING

#### Risque D'Incendie ou D'Explosion

Le non respect des mises en garde pourrait entraîner des blessures graves, la mort, ou des pertes matérielles. Prendre soin de lire et de comprendre les instructions d'installation, de fonctionnement et d'entretien contenues dans ce guide. Une installation, un réglage, une modification, une réparation ou un entretien inapproprié peut entraîner des blessures graves, la mort, ou des pertes matérielles.

- Ne pas entreposer ni utiliser d'essence ou autre vapeurs ou liquides inflammables à proximité de cet appareil ou de tout autre appareil.
- **QUE FAIRE SI VOUS SENTEZ UNE ODEUR DE GAZ**
- Ne tentez pas d'alumer un appareil.
- Ne touchez pas à un interrupteur; n'utilisez pas de téléphone dans l'édifice ou vous trouvez.
- Sortez de l'édifice immédiatement.
- Appelez immédiatement le fournisseur de gaz à partir d'un téléphone à l'extérieur de l'édifice. Suivez les instructions du fournisseur de gaz.
- Si vous ne pouvez joindre le fournisseur de gaz, appelez les pompiers.
  - L'installation et les réparations doivent être confiées à un installateur qualifié ou au fournisseur de gaz.

**The Rebel Applied rooftop unit is equipped with a louvered furnace access door to supply adequate combustion air. The unit includes a factory supplied flue assembly and requires no additional field supplied parts such as a chimney, flue pipe, Breidert cap, draft inducer, etc.**

#### Installation

1. Inspect the gas furnace module upon arrival for any damage that may have occurred during shipping.
2. Locate rating plate and verify that the furnace fuel supply and power requirements are met at the point of installation.

#### Electrical Requirements

All electrical equipment must be grounded and wired in accordance with the National Electric Code (ANSI/NFPA 70) in the US and the Canadian Electric Code (CSA C22.1) in Canada as well as any codes of the local jurisdiction in which the equipment is installed. If any original wire supplied with the appliance must be replaced, it must be replaced with wiring material having a temperature rating of at least 90°C / 194°F and VW-1 flammability classification requirement.

#### Flue Installation

Flue assemblies are shipped secured to the interior of the supply fan section. Remove flues from shipping straps by removing the bolts securing the strap to the upstream side of the furnace vestibule. Straps may be discarded while strap hardware should be reinstalled in their respective holes. Return to the furnace section and remove flue blank off plates. Retain hardware and use to mount flues to flue openings.

## Condensate Management

### NOTICE

Furnace condensate is acidic and may discolor roofing materials. It is the responsibility of the end user or contractor to determine if the condensate will damage roofing material. If applicable codes or regulations require, the condensate must be or routed to a field supplied and installed drain system.

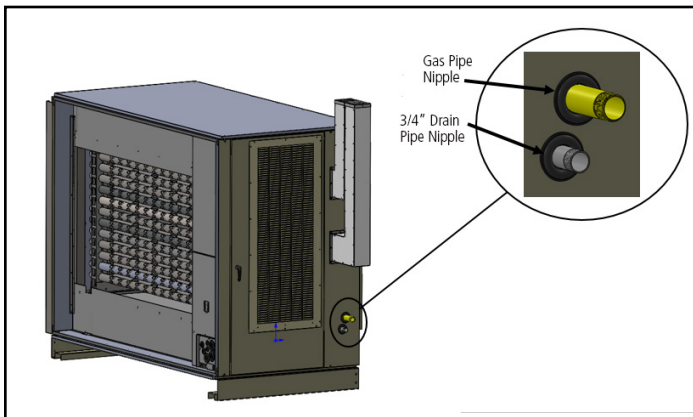


### CAUTION

Condensate may freeze if it is not properly piped to a drain or provided with some form of heat protection. Frozen drain lines may cause accumulation of condensate inside the heat exchanger which may result in damage to the rooftop equipment and the facility.

All units are equipped with a 3/4 in. NPT stainless steel condensate drain pipe projecting from the vestibule side of the furnace section, below the fuel gas inlet. Note that the condensate drain pipe nipple is the lower of the two pipe nipples, reference [Figure 220](#). Drainage of condensate directly onto the roof may be acceptable in some jurisdictions; it is the responsibility of the end user or contractor to determine if the condensate will damage roofing material. If applicable local codes or regulations require, condensate must be routed to a field supplied and installed drain system.

**Figure 220: Condensate Drain Field Connection Detail**



## DPSA Gas Furnace Capacity Data

Table 39: DPSA Natural Gas Furnace Capacity Table

Natural Gas										
Cabinet Size	Heat Size MBH (kW)	Rated Output MBH (kW)	Control	Rated Input Low/High MBH (kW)	Rated Temp Rise °F (°C)	Min Airflow CFM (M3/HR)	DAA Part Number	Supply Pressure, Min-Max IN WC (kPa)	Efficiency %	Max Temp Out: °F (°C)
B	200 (59)	162 (47)	2 Stage	100/200 (29/59)	25 (13.9)	5972 (10146)	404229301	5-14 (1.2-3.5)	81	120 (49)
			5:1 Modulating	40/200 (12/59)			404229302			
	400 (120)	324 (95)	2 Stage	200/400 (59/120)	50 (27.8)	4266 (7248)	404229201			
					70 (38.9)		404229202			
			5:1 Modulating	80/400 (23/120)	50 (27.8)	5972 (10146)				
					70 (38.9)	4266 (7248)				
			10:1 Modulating	40/400 (12/120)	50 (27.8)	5972 (10146)	404229203			
					70 (38.9)	4266 (7248)				
	600 (180)	486 (140)	2 Stage	300/600 (88/180)	50 (27.8)	8959 (15221)	404229107, 404229115			
					70 (38.9)	6399 (10872)				
			4 Stage	150/600 (44/180)	50 (27.8)	8959 (15221)	404229101, 404229109			
					70 (38.9)	6399 (10872)				
			5:1 Modulating	120/600 (35/180)	50 (27.8)	8959 (15221)	404229102, 404229110			
					70 (38.9)	6399 (10872)				
			10:1 Modulating	60/600 (18/180)	50 (27.8)	8959 (15221)	404229103, 404229111			
					60 (33.3)	7465 (12683)				
					70 (38.9)	6399 (10872)				
					100 (55.6)	4479 (7610)				
			20:1 Modulating	30/600 (8.8/180)	60 (33.3)	7465 (12683)	404322006			
					100 (55.6)	4479 (7610)				
	800 (230)	648 (190)	10:1 Modulating	80/800 (23/230)	60 (33.3)	9954 (16912)	404229001			
					100 (55.6)	5972 (10146)				
			20:1 Modulating	40/800 (12/230)	60 (33.3)	9954 (16912)	404229002			
					100 (55.6)	5972 (10146)				
1125 (330)	911 (270)	10:1 Modulating	110/1125 (33/330)	60 (33.3)	13998 (23783)	404228901				
				100 (55.6)	8399 (14270)					
		20:1 Modulating	56/1125 (16/330)	60 (33.3)	13998 (23783)	404228902				
				100 (55.6)	8399 (14270)					

Natural Gas										
Cabinet Size	Heat Size MBH (kW)	Rated Output MBH (kW)	Control	Rated Input Low/High MBH (kW)	Rated Temp Rise °F (°C)	Min Airflow CFM (M3/HR)	DAA Part Number	Supply Pressure, Min-Max IN WC (kPa)	Efficiency %	Max Temp Out: °F (°C)
C	400 (120)	324 (95)	2 Stage	200/400 (59/120)	15 (8.3)	19908 (33824)	404229201	5-14 (1.2-3.5)	81	120 (49)
			5:1 Modulating	80/400 (23/120)			404229202			
			10:1 Modulating	40/400 (12/120)			404229203			
	600 (180)	486 (140)	2 Stage	300/600 (88/180)	50 (27.8)	8959 (15221)	404229107, 404229115			
			4 Stage	150/600 (44/180)			404229101, 404229109			
			5:1 Modulating	120/600 (35/180)			404229102, 404229110			
				60/600 (18/180)			404229103, 404229111			
	800 (230)	648 (190)	10:1 Modulating	80/800 (23/230)	75 (41.7)	11945 (20295) 7963 (13529)	404229001			
			20:1 Modulating	40/800 (12/230)	50 (27.8) 75 (41.7)	11945 (20295) 7963 (13529)	404229002			
	1125 (330)	911 (270)	10:1 Modulating	110/1125 (33/330)	60 (33.3)	13998 (23783)	404228901			
					100 (55.6)	8399 (14270)				
			20:1 Modulating	56/1125 (16/330)	60 (33.3)	13998 (23783)	404228902			
					100 (55.6)	8399 (14270)				
	1500 (440)	1215 (360)	10:1 Modulating	150/1500 (44/440)	60 (33.3)	18664 (31710)	404239001, 4042338901			
					100 (55.6)	11198 (19026)				
			20:1 Modulating	75/1500 (22/440)	60 (33.3)	18664 (31710)	404239002, 4042338901			
					100 (55.6)	11198 (19026)				

**Table 40: DPSA Propane Gas Furnace Capacities Capacity Table**

Propane Gas										
Cabinet Size	Heat Size MBH (kW)	Rated Output MBH (kW)	Control	Rated Input Low/High MBH (kW)	Rated Temp Rise °F (°C)	Min Airflow CFM (M3/HR)	DAA Part Number	Supply Pressure, Min-Max IN WC (kPa)	Efficiency %	Max Temp Out: °F (°C)
B	200 (59)	162 (47)	2 Stage	100/200 (29/59)	25 (13.9)	5972 (10146)	404229303	11-14 (2.7-3.5)	81	120 (49)
			5:1 Modulating	40/200 (12/59)			404229304			
	400 (120)	324 (95)	2 Stage	200/400 (59/120)	50 (27.8)	4266 (7248)	404229204			
					70 (38.9)	5972 (10146)	404229205			
			5:1 Modulating	80/400 (23/120)	50 (27.8)	4266 (7248)				
					70 (38.9)	5972 (10146)				
			10:1 Modulating	40/400 (12/120)	50 (27.8)	4266 (7248)	404229206			
					70 (38.9)	5972 (10146)				
	600 (180)	486 (140)	2 Stage	300/600 (88/180)	50 (27.8)	8959 (15221)	404229108, 404229116			
					70 (38.9)	6399 (10872)				
			4 Stage	150/600 (44/180)	50 (27.8)	8959 (15221)	404229104, 404229112			
					70 (38.9)	6399 (10872)				
			5:1 Modulating	120/600 (35/180)	50 (27.8)	8959 (15221)	404229105, 404229113			
					70 (38.9)	6399 (10872)				
			10:1 Modulating	60/600 (18/180)	50 (27.8)	8959 (15221)	404229106, 404229114			
					60 (33.3)	7465 (12683)				
					70 (38.9)	6399 (10872)				
					100 (55.6)	4479 (7610)				
			20:1 Modulating	30/600 (8.8/180)	60 (33.3)	7465 (12683)	404322007			
					100 (55.6)	4479 (7610)				
	800 (230)	648 (190)	6:1 Modulating	130/800 (39/230)	60 (33.3)	9954 (16912)	404229003			
					100 (55.6)	5972 (10146)				
			12:1 Modulating	67/800 (20/230)	60 (33.3)	9954 (16912)	404229004			
					100 (55.6)	5972 (10146)				
1125 (330)	911 (270)	6:1 Modulating	190/1125 (55/330)	60 (33.3)	13998 (23783)	404228903				
				100 (55.6)	8399 (14270)					
		12:1 Modulating	94/1125 (27/330)	60 (33.3)	13998 (23783)	404228904				
				100 (55.6)	8399 (14270)					

Propane Gas										
Cabinet Size	Heat Size MBH (kW)	Rated Output MBH (kW)	Control	Rated Input Low/High MBH (kW)	Rated Temp Rise °F (°C)	Min Airflow CFM (M3/HR)	DAA Part Number	Supply Pressure, Min-Max IN WC (kPa)	Efficiency %	Max Temp Out: °F (°C)
C	400 (120)	324 (95)	2 Stage	200/400 (59/120)	15 (8.3)	19908 (33824)	404229204	11-14 (2.7-3.5)	81	120 (49)
			5:1 Modulating	80/400 (23/120)			404229205			
			10:1 Modulating	40/400 (12/120)			404229206			
	600 (180)	486 (140)	2 Stage	300/600 (88/180)	50 (27.8)	8959 (15221)	404229108, 404229116	11-14 (2.7-3.5)	81	120 (49)
			4 Stage	150/600 (44/180)			404229104, 404229112			
			5:1 Modulating	120/600 (35/180)			404229105, 404229113			
			10:1 Modulating	60/600 (18/180)			404229106, 404229114			
	800 (230)	648 (190)	6:1 Modulating	130/800 (39/230)	75 (41.7)	11945 (20295) 7963 (13529)	404229003	12-14 (3-3.5)	81	120 (49)
			12:1 Modulating	67/800 (20/230)	50 (27.8) 75 (41.7)	11945 (20295) 7963 (13529)	404229004			
	1125 (330)	911 (270)	6:1 Modulating	190/1125 (55/330)	60 (33.3) 100 (55.6)	13998 (23783) 8399 (14270)	404228903	11-14 (2.7-3.5)	81	120 (49)
			12:1 Modulating	94/1125 (27/330)	60 (33.3) 100 (55.6)	13998 (23783) 8399 (14270)	404228904			
	1500 (440)	1215 (360)	6:1 Modulating	250/1500 (73/440)	60 (33.3) 100 (55.6)	18664 (31710) 11198 (19026)	404239003, 4042338902	12-14 (3-3.5)	81	120 (49)
			12:1 Modulating	130/1500 (37/440)	60 (33.3) 100 (55.6)	18664 (31710) 11198 (19026)	404239004, 4042338902			

## General Gas Furnace Information

### Drum-and-Tube Style Gas Furnace

Units equipped with a drum-and-tube style gas furnace will have a separate installation manual included. Consult that manual for specifics of drum-and-tube style installation and setup.

### Tubular Gas Furnace

This furnace must be installed in the designated non-combustible heat chamber of the cabinet. If it is removed, it is only to be replaced with an approved Original Manufacture Equipment Supplier furnace(s), installed and operated as specified by the approved Original Manufacture Equipment Supplier. It is not designed to have any portion of the heat exchanger outside the cabinet in which the furnace module is housed.

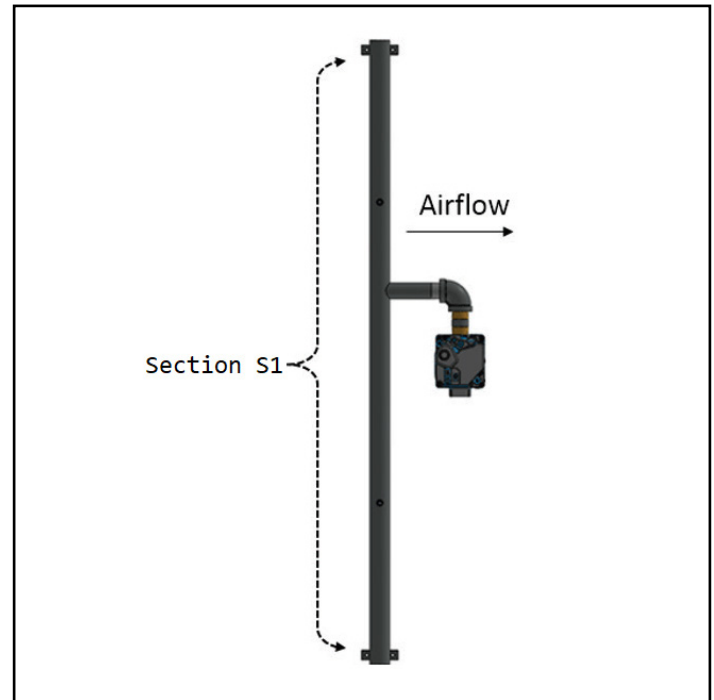
The Rating Plate/Name Plate has been permanently attached to the furnace assembly. It contains information including gas type, maximum and minimum input rating, manifold pressure, maximum and minimum inlet gas pressure, maximum and minimum airflow requirements, output capacity and electrical rating for the furnace. The plate also includes model number, serial number and scan code. This plate is to always remain attached to the furnace.

This furnace must be applied in accordance with the requirements of its listing. Louvered openings for combustion air have been provided in the furnace(s) access door. The air opening provides unrestricted combustion air to the burners and is sized such that a minimum free area is maintained. The minimum free area is defined as 1 in<sup>2</sup> (625 mm<sup>2</sup>) per 4000 BTUH (2.345 kW). The access door provides direct access to the furnace vestibule where the burners, combustion inducer fan, ignition controls and ignition safeties are housed. The vent discharge is sized such that it is equal to or larger than the discharge area of the combustion exhaust inducer fan. A non-adjustable High Limit Switch will shut off the gas supply to the main burners before the outlet air exceeds 250°F (121°C).

The cabinet supply air flow delivery package has been designed to provide sufficiently well distributed air flow across the heat exchanger to limit heat exchanger temperatures to 1330 °F (721°C).

## Gas Furnace Manifold Diagrams

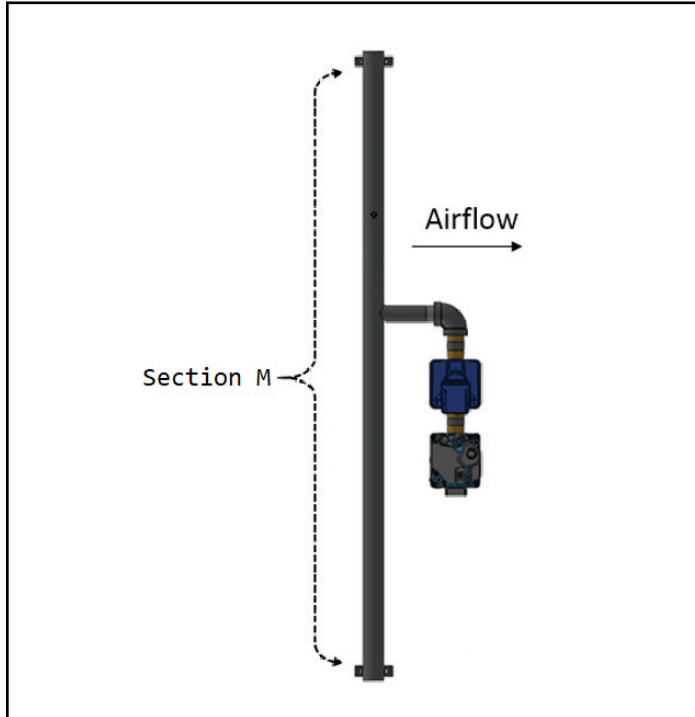
Figure 221: Staged Furnaces – 1 Standard Manifold



**NOTE:** Includes: 200 MBH (MQ104, MQ104LP), 400 MBH (MQ108, MQ108LP).

The noted furnaces are configured as one manifold section. One furnace control board is supplied with this furnace model. The VB1287 control board controls the staged Section S1 of the furnace manifold as shown in [Figure 221](#).

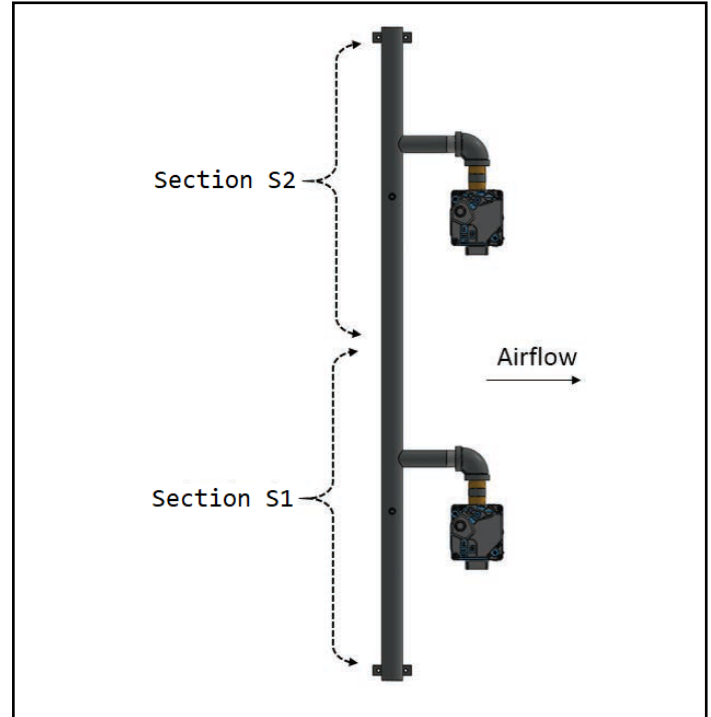
**Figure 222: Modulating Furnaces – 1 Standard Manifold**



**NOTE:** Includes: 200 MBH (MQ104MV, MQ104MVL), 400 MBH (Low Turn-Down: MQ108MV, MQ108MVL).

The noted furnaces are configured as one manifold section. One furnace control board is supplied with this furnace model. The VB1285 control board controls the modulating Section M of the furnace manifold as shown in [Figure 222](#).

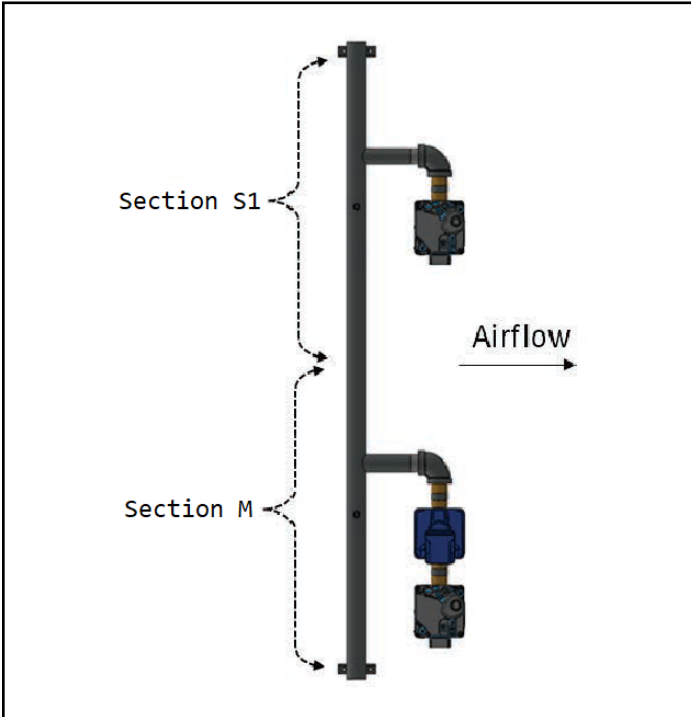
**Figure 223: Staged Furnaces – 1 Split Manifold**



**NOTE:** Includes: 600 MBH (MQ112, MQ112LP, MQ112-1, MQ112LP-1).

The noted furnaces are split into two manifold sections. One furnace control board is supplied with this furnace model. The VB1287 control board simultaneously controls both staged sections (S1 & S2) of the furnace manifold as shown in [Figure 223](#).

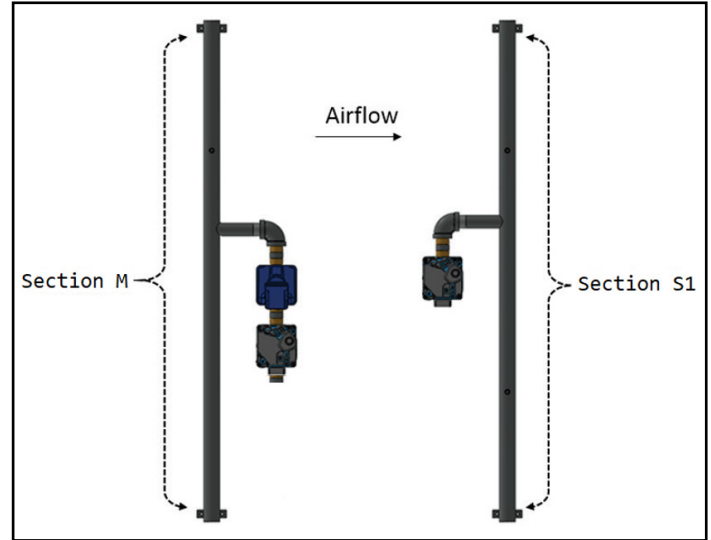
**Figure 224: Modulating Furnaces – 1 Split Manifold**



**NOTE:** Includes: 400 MBH (High Turn-Down: MQ108SP, MQ108SPLP), 600 MBH Furnaces (MQ112SP, MQ112SPLP, MQ112SP-1, MQ112SPLP-1).

The noted furnaces are split into two manifold sections. One furnace control board is supplied with this furnace model. The VB1285 control board simultaneously controls the modulating Section M and the staged Section S1 of the furnace manifold as shown in [Figure 224](#).

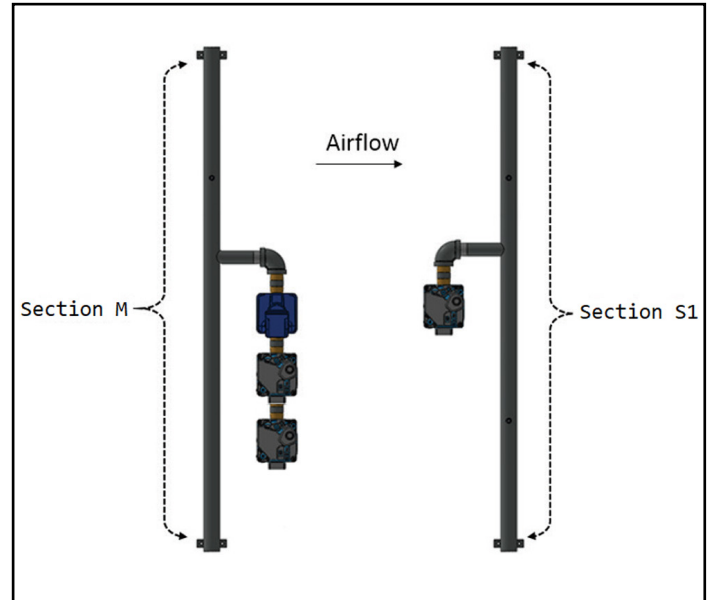
**Figure 225: Modulating Furnaces – 2 Standard Manifolds**



**NOTE:** 600 MBH (Dual Burner, Low Turn-Down: MQ614MV, MQ614MVLP).

The noted furnaces are split into two manifold sections. Two furnace control boards are supplied with this furnace model. The VB1285 control board controls the modulating Section M. The VB1287 control board controls the staged Section S1 of the furnace manifold as shown in [Figure 225](#).

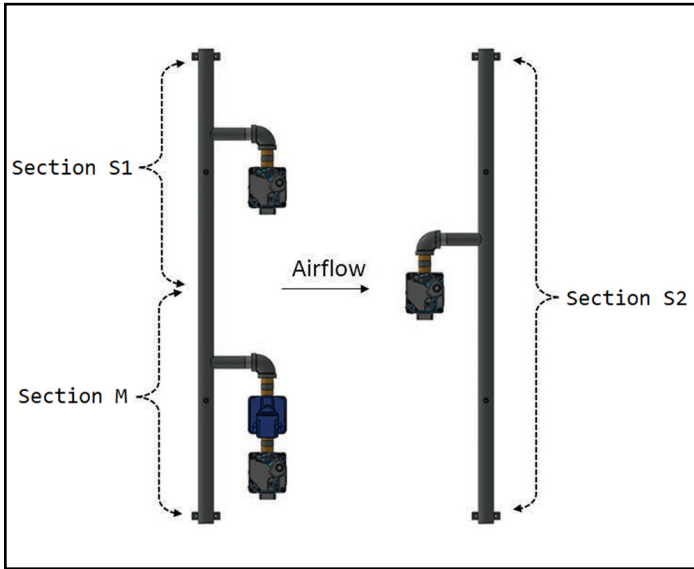
**Figure 226: Modulating Furnaces – 2 Standard Manifolds**



**NOTE:** Includes: 800 MBH (Low Turn-Down: MQ616MV, MQ616MVLP).

The noted furnaces are split into two manifold sections. Two furnace control boards are supplied with this furnace model. The VB1285 control board controls the modulating Section M. The VB1287 control board controls the staged Section S1 of the furnace manifold as shown in [Figure 226](#).

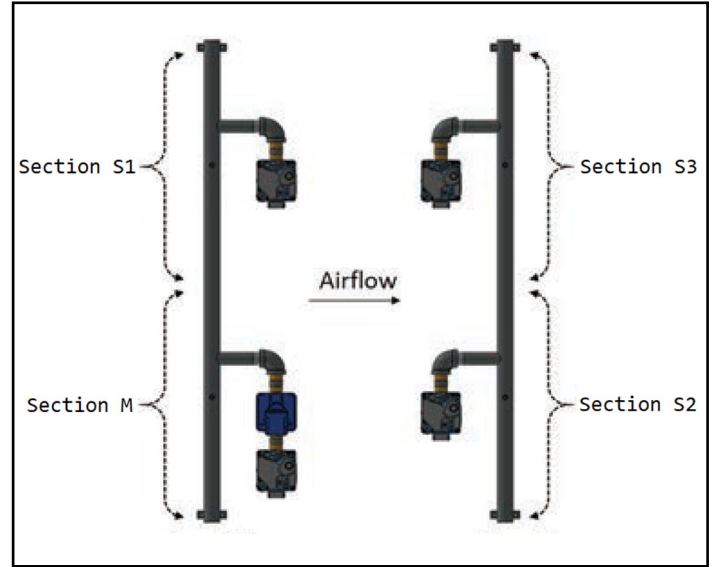
**Figure 227: Modulating Furnaces – 1 Standard Manifold, 1 Split Manifold**



**NOTE:** Includes: 800 MBH (High Turn-Down: MQ616SP, MQ616SPLP).

The noted furnaces are split into three manifold sections. Two furnace control boards are supplied with this furnace model. The VB1285 control board simultaneously controls the modulating Section M and the staged Section S1. The VB1287 control board controls the staged Section S2 of the furnace manifold as shown in [Figure 227](#).

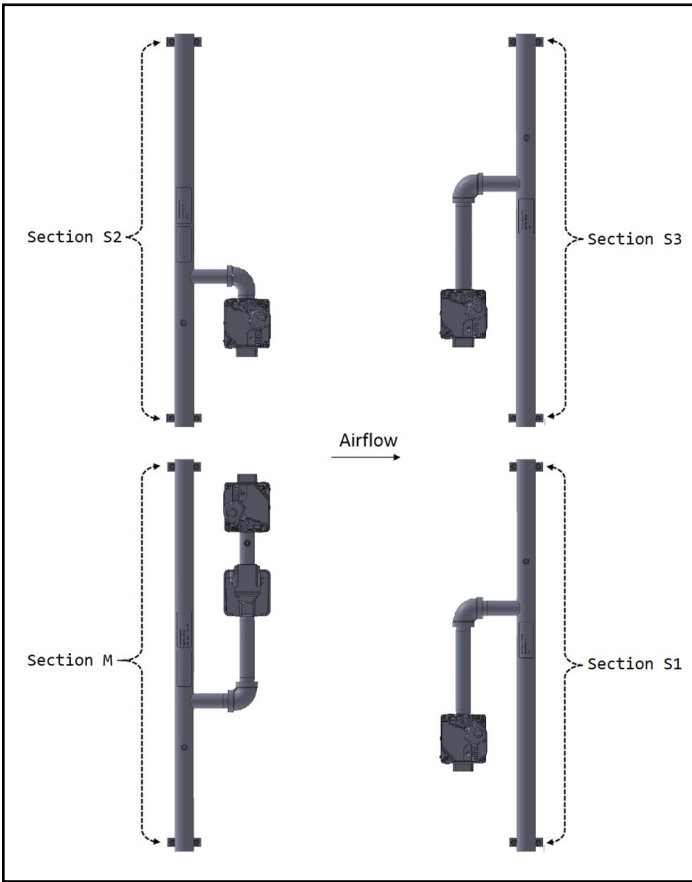
**Figure 228: Modulating Furnaces – 2 Split Manifolds**



**NOTE:** Includes: 1125 MBH (MQ624SP, MQ624SPLP, MQ624SP-1, MQ624SPLP-1).

The noted furnaces are split into four manifold sections. Two furnace control boards are supplied with this furnace model. The VB1285 control board simultaneously controls the modulating Section M and the staged Section S1. The VB1287 control board simultaneously controls two staged sections (S2 and S3) of the furnace manifold as shown in [Figure 228](#).

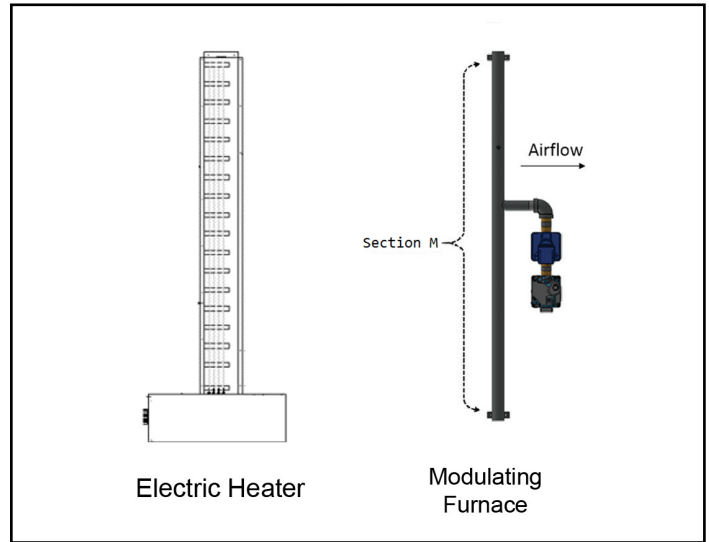
**Figure 229: Modulating Furnaces – 4 Standard Manifolds**



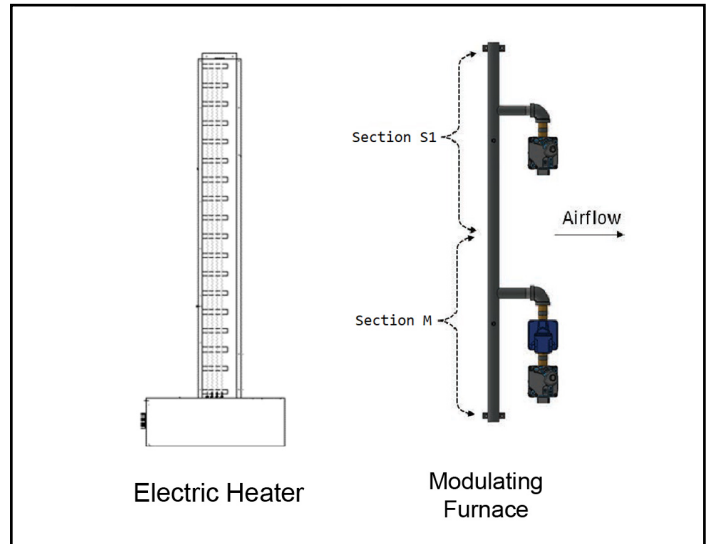
**NOTE:** Includes: 1500 MBH (MQ626, MQ626LP, MQ626MV, MQ626MVL, MQ626MV-1, MQ626MVL-1).

The noted furnaces use two 750 MBH furnace modules with two manifold sections each for a total of four manifold sections. The staged-only furnaces (MQ626, MQ626LP) are positioned on the top, and the modulating furnaces (all others) are positioned on the bottom. Four furnace control boards are supplied with this furnace model. One VB1285 control board controls the modulating Section M. One VB1287 control board controls each of the staged sections (S1, S2, and S3) of the furnace manifold as shown in Figure 229.

**Figure 230: Electric 200 MBH, 100:1**



**Figure 231: Electric 400 and 600 MBH, 100:1**



**Figure 232: Electric 600 MBH Dual and 800 MBH, 100:1**

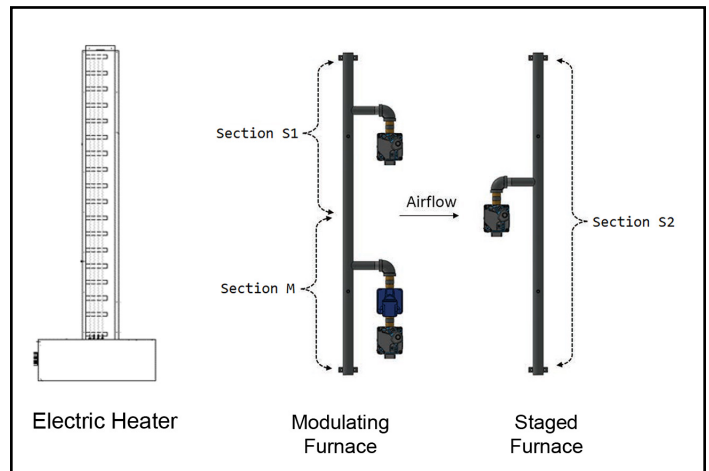


Figure 233: Electric 1125 MBH, 100:1

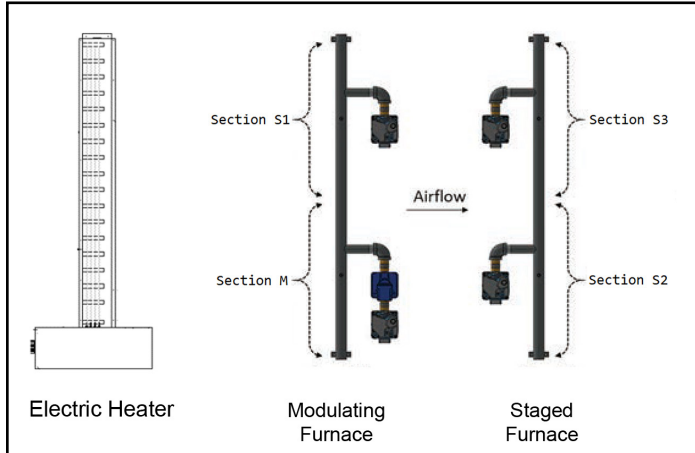
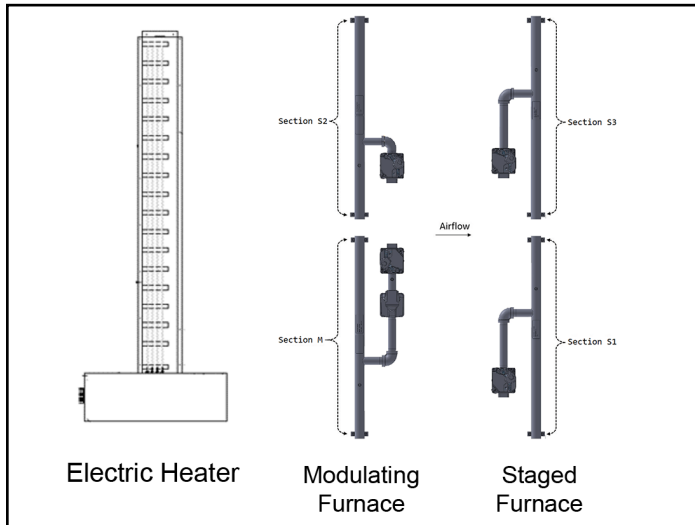


Figure 234: Electric 1500 MBH, 100:1



## Operating Procedures

### WARNING

#### Fire or Explosion Hazard

LOCKOUT/TAGOUT all power sources prior to installing the gas furnace. Failure to follow warnings exactly could result in serious injury, death, or property damage. Be sure to read and understand the installation, operation, and service instructions within this manual. Improper installation, adjustments, alterations, service, or maintenance can cause serious injury, death, or property damage.

- Do not store or use gasoline or other flammable vapors or liquids in the vicinity of this appliance.
- **What to do if you smell gas**
- Do not try to light any product that is fueled by or contains an open flame.
- Do not touch any electrical switch.
- Do not use any telephone in the building.
- Leave the building immediately.
- Immediately call the gas supplier from a remote telephone and follow the gas supplier's instructions.
- If you cannot reach the gas supplier, call the local fire department or 911.
  - Installation and service must be performed by a qualified installer, service agency, or gas supplier.

### WARNING

#### Risque D'Incendie ou D'Explosion

Le non respect des mises en garde pourrait entraîner des blessures graves, la mort, ou des pertes matérielles. Prendre soin de lire et de comprendre les instructions d'installation, de fonctionnement et d'entretien contenues dans ce guide. Une installation, un réglage, une modification, une réparation ou un entretien inapproprié peut entraîner des blessures graves, la mort, ou des pertes matérielles.

- Ne pas entreposer ni utiliser d'essence ou autre vapeurs ou liquides inflammables à proximité de cet appareil ou de tout autre appareil.
- **QUE FAIRE SI VOUS SENTEZ UNE ODEUR DE GAZ**
- Ne tentez pas d'allumer un appareil.
- Ne touchez pas à un interrupteur; n'utilisez pas de téléphone dans l'édifice où vous trouvez.
- Sortez de l'édifice immédiatement.
- Appelez immédiatement le fournisseur de gaz à partir d'un téléphone à l'extérieur de l'édifice. Suivez les instructions du fournisseur de gaz.
- Si vous ne pouvez joindre le fournisseur de gaz, appelez les pompiers.
  - L'installation et les réparations doivent être confiées à un installateur qualifié ou au fournisseur de gaz.

### WARNING

Replace and/or tighten all plugs removed or loosened when adjusting gas pressure. Leak test the fittings using a commercially available soap solution made specifically for the detection of leaks to check all connections. Failure to follow this warning could result in an explosion, fire, severe personal injury, death, or property damage.

### WARNING

Never test for gas leaks with an open flame. Testing with an open flame can cause an explosion or fire resulting in property damage, personal injury, or death. Use a commercially available soap solution made specifically for the detection of leaks to check all connections.

### ***Burner and Gas Manifold Pressure Adjustment***

Rebel Applied gas furnaces are available in a variety of staged and modulating configurations. Reference [Table 47 on page 160](#) to identify the pressure required at the various locations shown in [Figure 236 on page 156](#) based on furnace input capacity and modulation range. Follow the directions in the burner and gas manifold instructions section below based on modulation capacity.

## Field Gas Piping

**CAUTION**

Use a stabilizing wrench when installing field gas piping in order to prevent damage to the factory supplied manifold assembly.

**DANGER**

Testing for gas leaks with an open flame can cause an explosion or fire resulting in property damage, personal injury, or death. Use a commercially available soap solution made specifically for the detection of leaks to check all connections.

**WARNING**

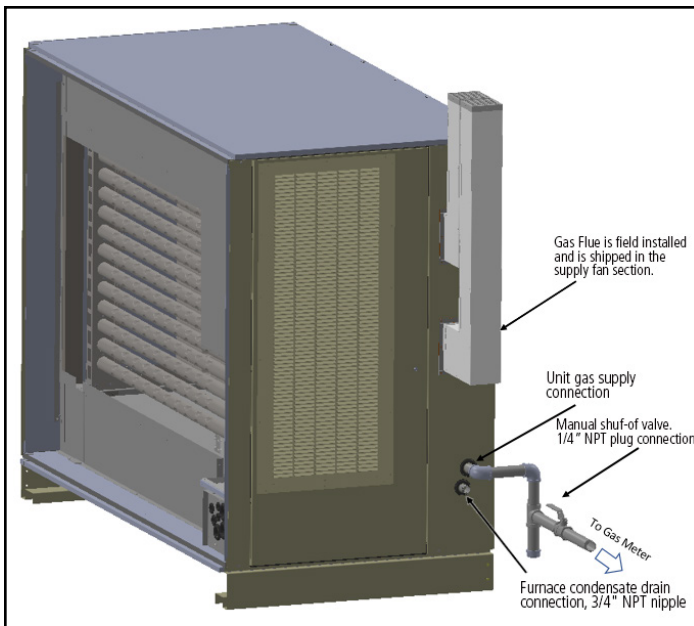
Overheating or failure of the gas supply to shut off can cause equipment damage, severe personal injury, or death. Turn off the manual gas valve to the appliance before shutting off the electrical supply.

**WARNING**

**Gas Explosion Hazard**

Do not attempt to connect gas lines to the condensate drain nipple. Open furnace vestibule and positively identify the proper gas manifold connection point. Failure to connect gas lines to the proper gas manifold connection point may result in serious injury or death.

Figure 235: DPSA Gas Furnace Field Connection Detail



1. Follow all applicable NFPA and local code requirements for gas supply piping to the unit. Ensure pipe routing does not interfere with downstream access doors and general unit accessibility. Suggested routing and items shown in Figure 235. Note that two nipples connections are provided at the furnace section. The upper pipe nipple is the fuel gas supply connection and is sized based on unit input capacity. See Table 41. The lower, 3/4 in. NPT nipple is connected to the vestibule condensate drain pan. Only connect gas to the unit gas supply connection point.
2. Field piping to be installed and supported such that it does not generate any load on the factory supplied gas train.
3. The appliance must be isolated from the gas supply system by closing off the manual shut off valve of the gas supply piping system during any pressure testing less than 0.5 psi (3.5 kPa).
4. The appliance and its individual shut-off valve must be disconnected from the gas supply system during any pressure testing greater than or equal to 0.5 psi (3.5 kPa).
5. Regulator to be sized for the maximum total Btu input required for the furnace.

Table 41: DPSA Gas Furnace Fuel Pipe Sizing

Furnace Capacity	Gas Pipe Size
200MBH, 400MBH, 600MBH	1.25 in. NPT
800MBH, 1125MBH, 1500MBH	1.5 in. NPT

## Gas Pressure Requirements

Inlet gas pressure must be maintained at 7.0 in. W.C. for Natural Gas and 11.0 in. W.C. for Propane. Maximum inlet pressure must not exceed 13.0 in. W.C. to prevent damage to the gas valve.

Gas piping must be sized and routed to provide the minimum required pressure when the burner is operating at maximum input. Consult your local utility on any questions on gas pressure available, allowable pipe pressure drops, and local piping requirements. Table 42, Table 43, and Table 44 provided for sizing reference.

Install all piping in accordance with the National Fuel Gas Code (ANSI Z223.1), (NFPA 54-1999) and any applicable local codes.

Remove all burrs and obstructions from pipe. A drip leg must be installed in the vertical line before each burner such that it will not freeze. All pipe threads must have a pipe dope which is resistant to the action of LP gas.

After installation, pressurize the piping as required and test all joints for tightness with a rich soap solution or UL 913 combustible gas leak detector. Any bubbling is considered a leak and must be eliminated.

**Table 43: Conversion for Specific Gravities other than 0.60**

Natural Gas	Multiplier
0.50	1.100
0.60	1.000
0.70	0.936
0.80	0.867
0.90	0.816
1.00	0.775
Propane-Air	Multiplier
1.10	0.740
Propane	Multiplier
1.55	0.622
Butane	Multiplier
2.00	0.547

**Table 44: Conversion for Pressure Drop other than 0.3 in.**

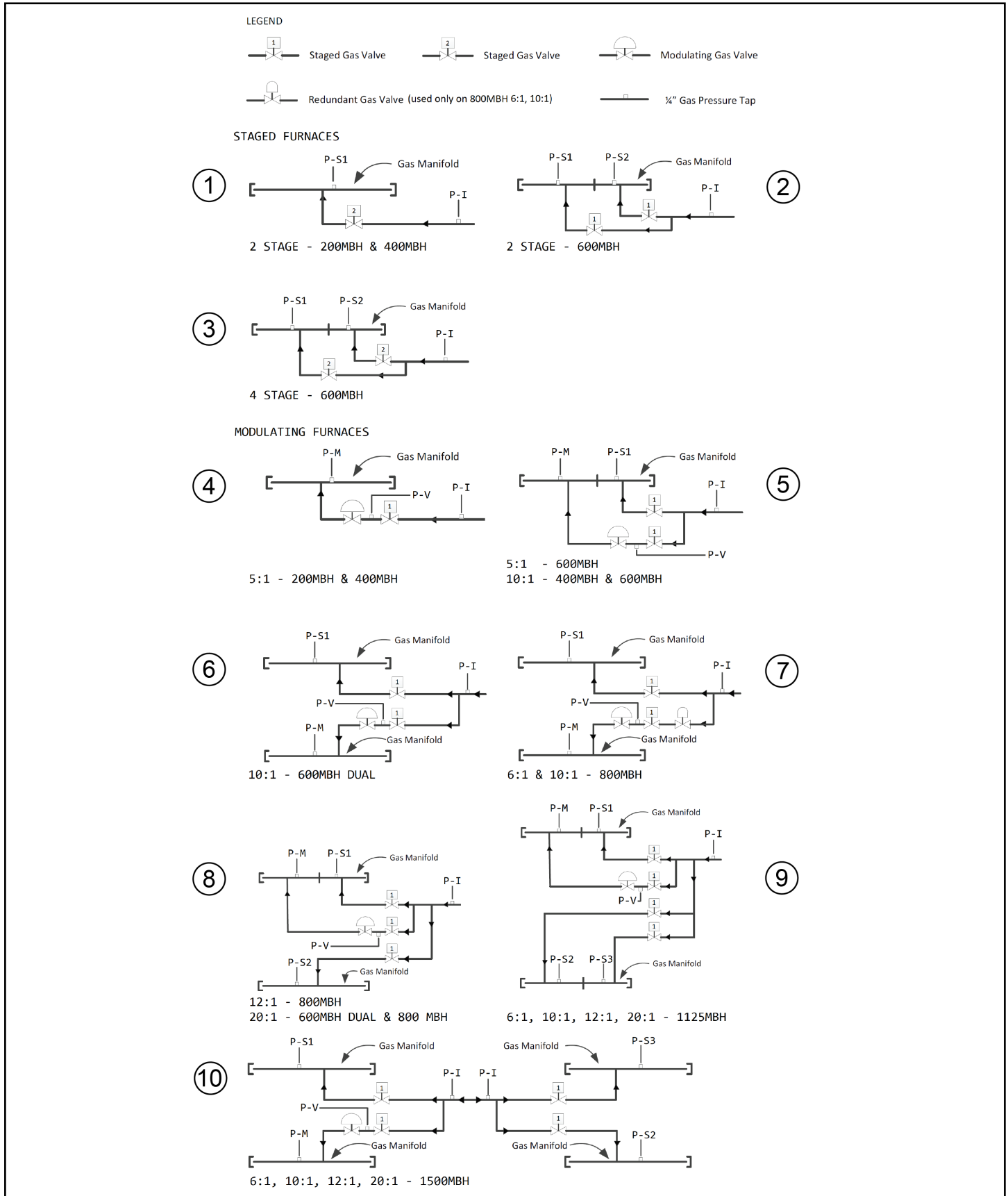
Inches W.C. Pressure Drop	Multiplier	Inches W.C. Pressure Drop	Multiplier
0.1	0.577	1.0	1.83
0.2	0.815	2.0	2.58
0.3	1.000	3.0	3.16
0.4	1.16	4.0	3.65
0.6	1.42	6.0	4.47
0.8	1.64	8.0	5.15

**Table 42: Natural Gas Pipe Flow Capacity\* (CFH)**

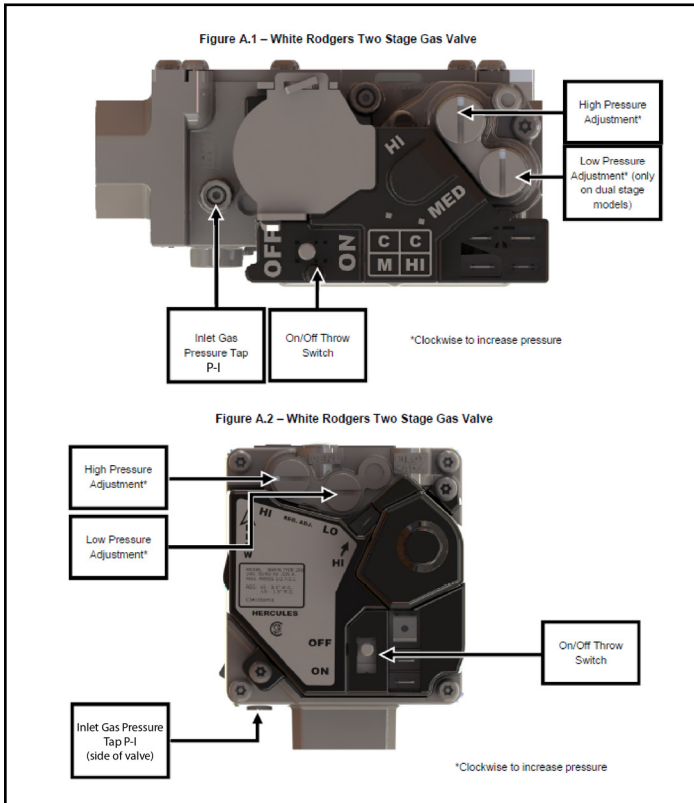
Pipe Length (ft)	Gas Capacity in CFH								
	Pipe Size-inches (Ips)								
	½	¾	1	1¼	1½	2	2½	3	4
10	132	278	520	1050	1600	2050	4800	8500	17500
20	92	190	350	730	1100	2100	3300	5900	12000
30	73	152	285	590	890	1650	2700	4700	9700
40	63	130	245	500	760	1450	2300	4100	8300
50	56	115	215	440	670	1270	2000	3600	7400
60	50	105	195	400	610	1150	1850	3250	6800
70	46	96	180	370	560	1050	1700	3000	6200
80	53	90	170	350	530	990	1600	2800	5800
90	40	84	160	320	490	930	1500	2600	5400
100	38	79	150	305	460	870	1400	2500	5100
125	34	72	130	275	410	780	1250	2200	4500
150	31	64	120	250	380	710	1130	2000	4100
175	28	59	110	225	350	650	1050	1850	3800
200	26	55	100	210	320	610	980	1700	3500

\*Assuming Pressure Drop of 0.3 in. W.C. & Specific Gravity of 0.60

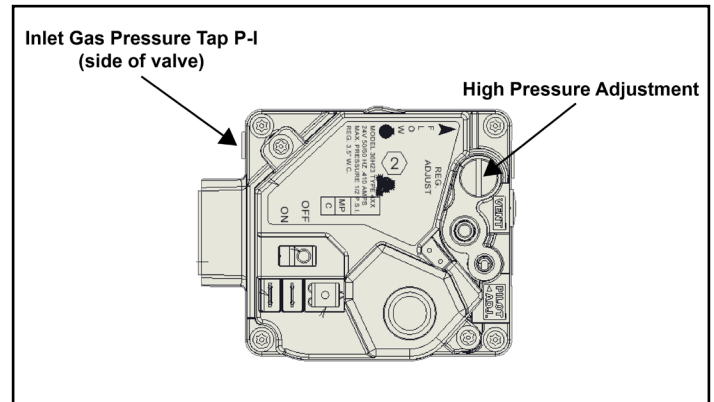
Figure 236: Diagrams for Pressure Measurement Locations



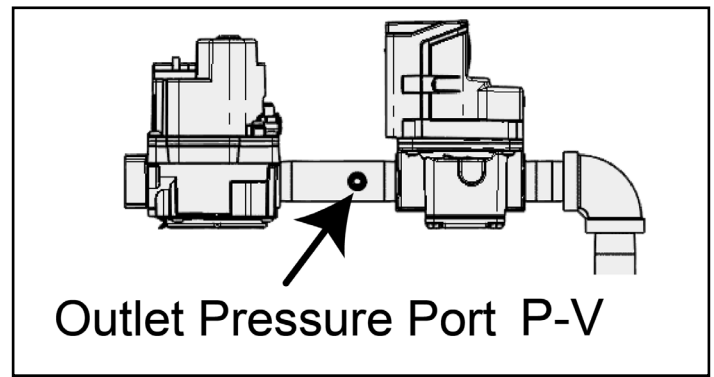
**Figure 237: Staged Gas Safety Control**



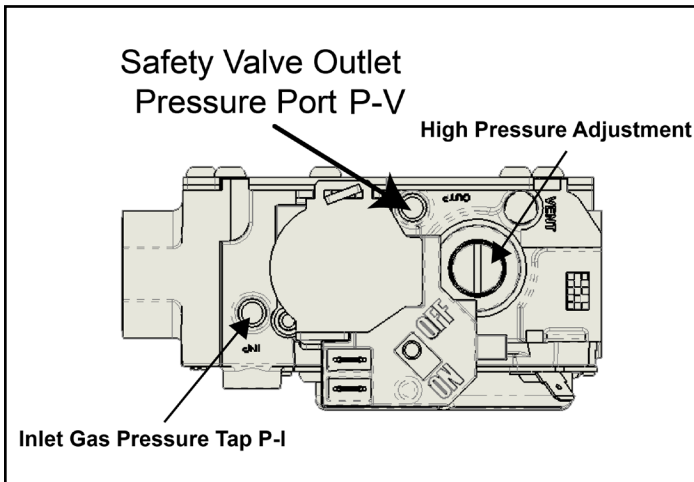
**Figure 239: White Rodgers Single Stage Gas Valve (for sections above 200 MBH)**



**Figure 240: Outlet Pressure Port Location**



**Figure 238: White Rodgers Single Stage Gas Valve (for sections at 200 MBH and below)**



**Table 45: Furnace Gas Pressure Itemization (Natural Gas)**

Natural Gas																		
Modulation	2-Stage			4-Stage	5:1 Modulation			10:1 Modulation					20:1 Modulation					
Heat Input Capacity: MBH (kW)	200 (59)	400 (120)	600 (180)	600 (180)	200 (59)	400 (120)	600 (180)	400 (120)	600 (180)	600 (180)	800 (230)	1125 (330)	1500 (440)	600 (180)	800 (230)	1125 (330)	1500 (440)	
Figure (see page 156)	1	1	2	3	4	4	5	5	5	6	7	9	10	8	8	9	10	
DAA Part Number(s)	404229301	404229201	404229107, 404229115	404229101, 404229109	404229302	404229202	404229102, 404229110	404229203	404229103, 404229111	404322004	404229001	404228901	404239001, 404238901	404322006	404229002	404228902	404239002, 404238901	
P-I: in. W.C. (kPa)	5 (1.2)																	
P-M: in. W.C. (kPa)	High	-	-	-	-	3.5 (0.87)	3.5 (0.87)	3.5 (0.87)	3.5 (0.87)	3.5 (0.87)	3.5 (0.87)	3.9 (0.97)	3.5 (0.87)	3.8 (0.95)	3.5 (0.87)	3.9 (0.97)	3.5 (0.87)	3.8 (0.95)
	Low	-	-	-	-	0.19 (0.047)	0.18 (0.045)	0.56 (0.14)	0.16 (0.04)	0.15 (0.037)	0.2 (0.05)	0.24 (0.06)	0.56 (0.14)	0.67 (0.17)	0.2 (0.05)	0.21 (0.052)	0.2 (0.05)	0.2 (0.05)
P-S1: in. W.C. (kPa)	High	3.5 (0.87)	3.5 (0.87)	3.5 (0.87)	3.5 (0.87)	-	-	3.5 (0.87)	3.5 (0.87)	3.5 (0.87)	3.2 (0.8)	3.2 (0.8)	3.5 (0.87)	3.2 (0.8)	3.5 (0.87)	3.9 (0.97)	3.5 (0.87)	3.2 (0.8)
	Low	1.1 (0.27)	1.1 (0.27)	-	1.1 (0.27)	-	-	-	-	-	-	-	-	-	-	-	-	-
P-S2: in. W.C. (kPa)	High	-	-	3.5 (0.87)	3.5 (0.87)	-	-	-	-	-	-	-	3.2 (0.8)	3.8 (0.95)	3.2 (0.8)	3.2 (0.8)	3.2 (0.8)	3.8 (0.95)
	Low	-	-	-	1.1 (0.27)	-	-	-	-	-	-	-	-	-	-	-	-	-
P-S3: in. W.C. (kPa)	High	-	-	-	-	-	-	-	-	-	-	-	3.2 (0.8)	3.2 (0.8)	-	-	3.2 (0.8)	3.2 (0.8)
	Low	-	-	-	-	-	-	-	-	-	-	-	-	-	-	-	-	-
P-S4: in. W.C. (kPa)	High	-	-	-	-	-	-	-	-	-	-	-	-	-	-	-	-	-
	Low	-	-	-	-	-	-	-	-	-	-	-	-	-	-	-	-	-
P-V: in. W.C. (kPa)	Min	4.5 (1.12)																
	Max	4.0 (1.00)																

**NOTE:** All pressures are set at the factory based on standard inlet pressure and should not need to be adjusted for normal installation. Adjust pressures only if other troubleshooting options have been exhausted.

**Table 46: Furnace Gas Pressure Itemization (Propane)**

Propane																	
Modulation	2-Stage			4-Stage	5:1 Modulation			10:1 Modulation			6:1 Modulating			20:1 Modulation	12:1 Modulating		
Heat Input Capacity: MBH (kW)	200 (59)	400 (120)	600 (180)	600 (180)	200 (59)	400 (120)	600 (180)	400 (120)	600 (180)	600 (180)	800 (230)	1125 (330)	1500 (440)	600 (180)	800 (230)	1125 (330)	1500 (440)
Figure (see page 156)	1	1	2	3	4	4	5	5	5	6	7	9	10	8	8	9	10
DAA Part Number(s)	404229303	404229204	404229108, 404229116	404229104, 404229112	404229304	404229205	404229105, 404229113	404229206	404229106, 404229114	404322005	404229003	404228903	404239003, 404238902	404322007	404229004	404228904	404239004, 404238902
P-I: in. W.C. (kPa)	11 (2.7)	11 (2.7)	11 (2.7)	11 (2.7)	11 (2.7)	11 (2.7)	11 (2.7)	11 (2.7)	11 (2.7)	11 (2.7)	12 (3)	11 (2.7)	12 (3)	11 (2.7)	12 (3)	11 (2.7)	12 (3)
P-M: in. W.C. (kPa)	High	-	-	-	10 (2.5)	10 (2.5)	10 (2.5)	10 (2.5)	10 (2.5)	10 (2.5)	11 (2.7)	10 (2.5)	10 (2.5)	10 (2.5)	11 (2.7)	10 (2.5)	10 (2.5)
	Low	-	-	-	0.56 (0.14)	0.43 (0.11)	1.6 (0.4)	0.43 (0.11)	1.6 (0.4)	0.75 (0.19)	1.2 (0.3)	4.5 (1.1)	2 (0.5)	0.75 (0.19)	1.2 (0.3)	1.1 (0.27)	0.69 (0.17)
P-S1: in. W.C. (kPa)	High	10 (2.5)	10 (2.5)	10 (2.5)	-	-	10 (2.5)	10 (2.5)	10 (2.5)	8.8 (2.2)	8.8 (2.2)	10 (2.5)	10 (2.5)	10 (2.5)	11 (2.7)	10 (2.5)	10 (2.5)
	Low	3.1 (0.77)	3.1 (0.77)	-	3.1 (0.77)	-	-	-	-	-	-	-	-	-	-	-	-
P-S2: in. W.C. (kPa)	High	-	-	10 (2.5)	10 (2.5)	-	-	-	-	-	-	8.8 (2.2)	10 (2.5)	8.8 (2.2)	8.8 (2.2)	8.8 (2.2)	10 (2.5)
	Low	-	-	-	3.1 (0.77)	-	-	-	-	-	-	-	-	-	-	-	-
P-S3: in. W.C. (kPa)	High	-	-	-	-	-	-	-	-	-	-	8.8 (2.2)	10 (2.5)	-	-	8.8 (2.2)	10 (2.5)
	Low	-	-	-	-	-	-	-	-	-	-	-	-	-	-	-	-
P-S4: in. W.C. (kPa)	High	-	-	-	-	-	-	-	-	-	-	-	-	-	-	-	-
	Low	-	-	-	-	-	-	-	-	-	-	-	-	-	-	-	-
P-V: in. W.C. (kPa)	Min	11.5 (2.86)															
	Max	11 (2.74)															

**NOTE:** All pressures are set at the factory based on standard inlet pressure and should not need to be adjusted for normal installation. Adjust pressures only if other troubleshooting options have been exhausted.

## Burner and Gas Manifold Pressure Adjustment Instructions

For correct gas pressures referenced in these instructions, refer to [Table 45 on page 158](#) (Natural Gas) and [Table 46 on page 159](#) (Propane). For definition of pressure measurement locations, refer to [Figure 236 on page 156](#). For identification of valve components, refer to the figures beginning on [page 157](#).

### 2-Stage Furnaces

1. Read gas pressure at the Inlet Pressure Tap of the staged valve(s) and confirm pressure matches the value specified for your unit's capacity and modulation configuration. Adjust upstream pressure reducing gas regulator as required to obtain inlet pressure specified.
2. In main cabinet control panel, set Microtech 4 controller to manual mode. Specify high fire operation by setting "Htg Stage 2" menu item to ON. Back at the furnace, read gas pressure(s) on the burner manifold pressure tap. Confirm pressure matches the HIGH value specified for your unit's capacity and modulation configuration. If adjustment is required, adjust the HI regulator on the staged gas valve(s).
3. Only follow this step if your furnace uses a 2-stage gas valve. In main cabinet control panel, set MicroTech 4 controller to manual mode. If "Htg Stage 2" menu item is set to ON, turn it OFF. Specify low fire operation by setting "Htg Stage 1" menu item to ON. Back at the furnace, read gas pressure on the burner manifold pressure tap. Confirm pressure matches the LOW value specified for your unit's capacity and modulation configuration. If adjustment is required, adjust the Lo/Med regulator on the two stage gas valve.

### 4-Stage Furnaces

1. Read gas pressure at the Inlet Pressure Tap of the two stage valves and confirm pressure matches the value specified for your unit's capacity and modulation configuration. Adjust upstream pressure reducing gas regulator as required to obtain inlet pressure specified in.
2. In main cabinet control panel, set MicroTech 4 controller to manual mode. Specify high fire operation by setting all "Htg Stage" menu items to ON. Back at the furnace, read gas pressures on the burner manifold pressure taps. Confirm both pressures match the HIGH value specified for your unit's capacity and modulation configuration. If adjustment is required, adjust the HI regulator on the relevant two stage gas valve.
3. In main cabinet control panel, set MicroTech 4 controller to manual mode. If any "Htg Stage" menu items are ON, turn them OFF. Specify low fire operation by turning "Htg Stage 1" ON. Back at the furnace, read gas pressures on the burner manifold pressure taps. Confirm both pressures match the LOW value specified for your unit's capacity and modulation configuration. If adjustment is required, adjust the Lo/Med regulator on the relevant two stage gas valve.

## Modulating Furnaces

1. Read gas pressure at the Inlet Pressure Tap of the staged valve(s) and confirm pressure matches the value specified for your unit's capacity and modulation configuration. Adjust upstream pressure reducing gas regulator as required to obtain inlet pressure specified.
2. In main cabinet control panel, set MicroTech 4 controller to manual mode. Specify high fire operation by "Htg Valve" menu item to 100%. Continue to specify high fire operation by setting all available "Htg Stage" menu items to ON. Back at the furnace, read the gas pressures specified for your configuration on the burner manifold pressure taps. Confirm each pressure matches the HIGH value specified for each manifold for your unit's capacity and modulation configuration. If adjustment is required, adjust the HI regulator on the relevant staged gas valve. If the correct modulating manifold pressure cannot be achieved by adjusting the upstream staged safety valve, refer to "[Maxitrol EXA Star Controller](#)" on [page 161](#).
3. In main cabinet control panel, set MicroTech 4 controller to manual mode. Specify low fire operation by setting all available "Htg Stage" menu items to OFF. Continue to set low fire operation by setting the "Htg Valve" menu item to the applicable value shown in [Table 47](#).
4. At the furnace, read gas pressure on the burner manifold pressure tap. Confirm pressure matches the LOW value specified for your unit's capacity and modulation configuration. If adjustment is required, refer to "[Maxitrol EXA Star Controller](#)" on [page 161](#).

**Table 47: Modulating Furnace Low Fire "Htg Valve" Value**

Furnace Capacity	Natural Gas (NG)		Liquefied Petroleum (LP)	
	Modulation	Low Fire "Htg Valve" Setting	Modulation	Low Fire "Htg Valve" Setting
200 MBH (58.6 kW)	5:1	20%	5:1	20%
400 MBH (117.2 kW)	5:1	20%	5:1	20%
	10:1		10:1	
600 MBH (175.8 kW)	5:1	40%	5:1	40%
	10:1	20%	10:1	20%
	20:1		20:1	
800 MBH (234.5 kW)	10:1	20%	6:1	33%
	20:1		12:1	
1125 MBH (309.1 kW)	10:1	40%	6:1	63%
	20:1	20%	12:1	31%
1500 MBH (439.6 kW)	10:1	40%	6:1	67%
	20:1	20%	12:1	33%

## Maxitrol EXA Star Controller

### NOTICE

These instructions are intended for the adjustment and troubleshooting of the Maxitrol EXA (E40H and E50H) modulating gas valves used with the Beckett VB1285 modulating control. Always set manifold pressures to the value on the appliance's rating plate.

### WARNING

All adjustments should be made by a qualified service agency in accordance with the manufacturer's instructions and all applicable codes and requirements of the authority having jurisdiction. If the information in these instructions is not followed exactly, a fire, explosion or production of carbon monoxide may result causing property damage, personal injury, or death. The qualified service agency performing this work assumes the responsibility for the proper adjustment of the appliance.

### WARNING

Adjusting the Modulating valve beyond its physical limits may result in permanent damage to the valve and production of Carbon Monoxide during modulation. Serious injury and death can result if not adjusted correctly.

### Pre-Adjustment Verification

Prior to adjusting gas pressure, ensure the following items are checked and verified:

1. Check VB1285 ignition control for any error codes.
  - a. If error codes are present, unit performance may be affected. Clear error codes from the control by powering off for 10 seconds.
2. Verify inlet pressure to the safety valve is within the correct range per the appliance rating plate and adjust if necessary.
3. Verify gas pressure at the outlet of the safety valve is between:
  - 4.5 and 5.0 in. W.C. if NG
  - 11.0 11.5 in. W.C. if LP
  - If gas pressure is outside of the designated ranges, correct and check manifold pressure.
  - Refer to [Figure 237 on page 157](#) for location.
4. Remove modulating valve cover and verify that the modulating valve is wired correctly according to the following wire colors and description:
  - 24VAC (+) (Blue)
  - 24VAC (-) (Yellow)
  - 10VDC (+) (Red)
  - 10VDC (-) (White)
  - Ensure purple com wire is connected correctly, as shown in [Figure 243 on page 162](#)
  - Correct any wiring that is incorrect per the wiring diagram.
5. Verify that dip switches on the modulating valve are set correctly.
  - Switch 1 (OFF)

- Switch 2 (ON)
- Switch 3 (OFF)

### Primary Manifold Pressure Adjustment

1. Using the MicroTech unit controller's "Manual Control" menu, set the heating output to 100%.

**NOTE:** Ensure all required dampers are opened and adequate airflow is provided across the heating section in manual control prior to sending heat demand to the heating section.

2. If modulating manifold pressure is between 3.0 and 3.5 in. W.C., adjust by increasing safety valve pressure.
  - a. Remove the brass regulator screw on the safety valve.
  - b. Increase safety valve pressure by turning the plastic screw clockwise until the desired manifold pressure is achieved.
  - c. Replace the brass screw cover.

### Modulating Valve Setting Adjustment

#### WARNING

Adjusting the modulating valve beyond its physical limits may result in permanent damage to the valve and production of carbon monoxide (CO) during modulation. Serious injury and death can result if not adjusted correctly.

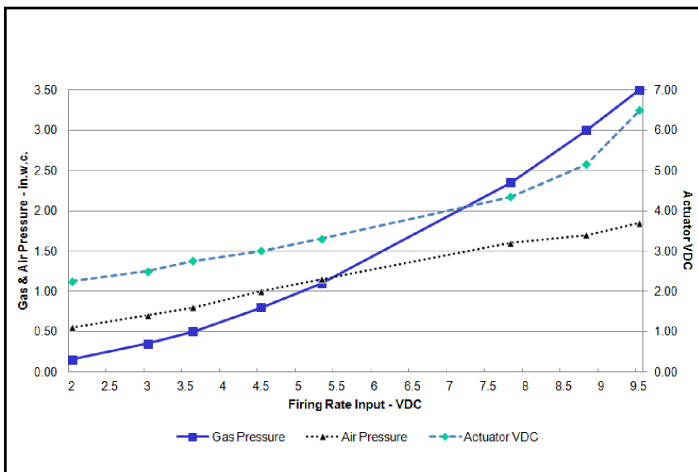
Use calibration procedure defined in "[Maxitrol EXA Star Valve Calibration](#)" on [page 191](#) if modulating valve is believed to be in a mechanically over-traveled state.

If safety valve outlet pressure is between 4.5 and 5.0 in. W.C. and modulating manifold pressure is below 3.0 in. W.C. (refer to [Figure 237 on page 157](#) for location). Modulating valve settings may need to be adjusted. Perform the following procedure to adjust the modulating valve:

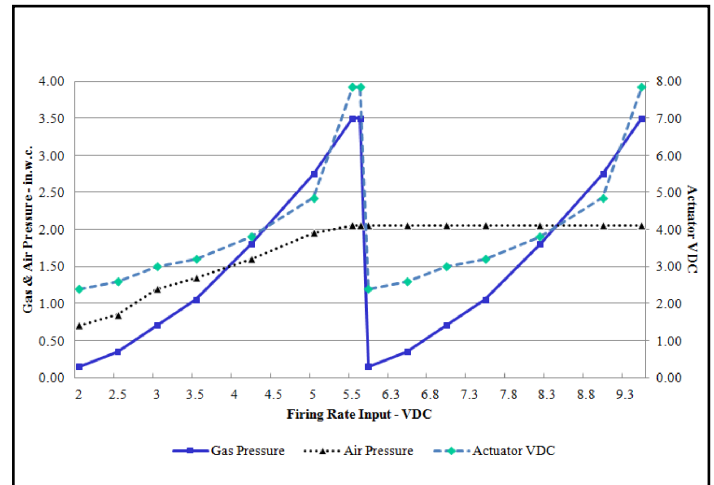
1. Remove the blue cover on the modulating valve.
2. For high input adjustment, press and hold button #1 until the red LED light comes on. Refer to [Figure 243 on page 162](#).
3. Once the red light is on, toggle between buttons #1 and #2 to adjust the manifold pressure.
  - Button #1 increases gas flow
  - Button #2 decreases gas flow
  - Each press of a button will move the set point of the valve up or down by one step. It is best to adjust with discrete clicks of the button so as not to drive the valve beyond its physical limits.
4. Press and hold both buttons simultaneously to set valve. Red light will turn off.
5. For low input adjustment, use the MicroTech unit controller's "Manual Control" menu to set the heating output to 25% or when the MicroTech unit controller outputs 2 VDC from the analog output.
6. Press and hold button #2 until the red LED starts flashing. Refer to [Figure 243 on page 162](#).

7. Once the LED starts flashing, toggle between button #1 and button #2 to adjust the manifold pressure.
  - Button #1 increases gas flow
  - Button #2 decreases gas flow
  - Each press of a button will move the set point of the valve up or down by one step. It is best to adjust with discrete clicks of the button so as not to drive the valve beyond its physical limits.
8. Press and hold both buttons simultaneously to set value.
9. Verify manifold pressure at high input did not change by sending a high input signal to the VB1285.
  - If the high input setpoint changed, return to Step 2 for high input adjustment and verify manifold pressure did not change.
10. Verify manifold pressure at low input did not change by sending a low input signal to the VB1285.
11. Once manifold pressure has been verified, replace the modulating Valve cover.

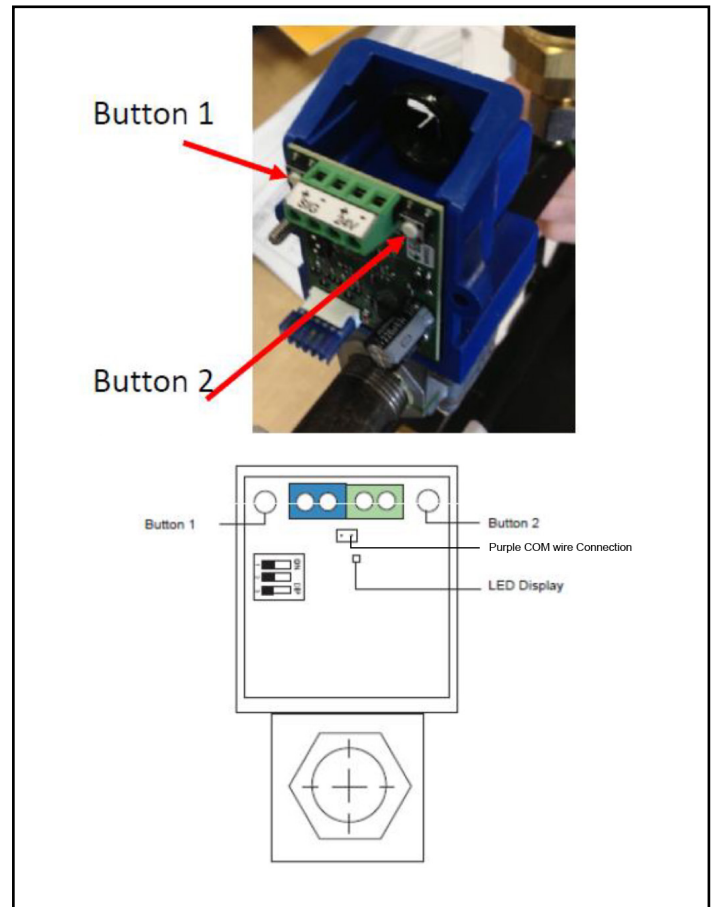
**Figure 241: Example Gas Curves: Single Stage Modulating Furnace**



**Figure 242: Example Gas Curves: Multi-Stage Modulating Furnace**



**Figure 243: Maxitrol EXA Star LEDs**



## Sequences of Operation

The following sequences of operation apply to individual control boards and the furnace sections they control (see figures beginning on [page 147](#)). In units with multiple control boards, the MicroTech controller will send signals separately to each of the control boards to control which furnace sections are engaged (see tables beginning on [page 165](#) for a summary of the engaged furnace sections).

**NOTE:** In instances where a gas furnace is paired with a heat pump unit, the unit's primary means of heating will be mechanical heating (heat pump) and will be used first to reach/maintain set points. If mechanical heating does not satisfy the demand, the auxiliary heating method (gas heat) will be utilized to fulfill the demand.

### VB1285 BPP Modulating Control - Standard and Split Manifolds

1. A call for heat is initiated by the rooftop unit control through a digital Modbus signal. Refrigeration Only control packages may differ.
2. The VB1285 control will then go through a system check to ensure that the high temperature limit and rollout switches are closed, the air pressure switch is open, and the modulating valve is positioned correctly.
3. The control will then enter the pre-purge cycle, where the inducer will run at the programmed purge pressure. During this cycle, the control will look for the air pressure switch to close and open at the correct settings.
4. Once the system check and pre-purge cycles are complete, the control will enter the ignition cycle.
  - a. The modulating valve and inducer will go to their "light off" settings.
  - b. The DSI ignition module will be energized and the spark ignitor will activate.
  - c. The redundant safety valve will open, allowing gas flow.
  - d. The burners will ignite and the control will receive a signal from the flame sensor.
  - e. The spark ignitor will remain active for the duration of the ignition cycle, regardless of flame status.
5. If flame is not established during the ignition cycle, the control will repeat the pre-purge and ignitions cycles up to three times. After three failed ignition attempts, the board will enter a 1 hour lockout.
6. Once flame has been established, the control will enter a warm-up period to ensure flame stabilization and reduce condensation in the heat exchanger.
7. After the warm-up period, the control will enter the run cycle. During the run cycle, the burner firing rate and draft inducer pressure are determined based on the heat demand received by the control via a Modbus signal.

**NOTE:** If the control is paired with a split manifold, steps 1 through 6 pertain to the primary burners. Once the

control exits the warm-up period and the firing rate is dictated by the rooftop control, the control will modulate the primary burners and ignite the secondary burners based on the demand for heat.

8. The run cycle will continue until any of the following conditions are met:
  - a. The call for heat is terminated
  - b. Any of the safety devices (high limit, air pressure, rollout, etc.) are triggered
  - c. The control reaches its maximum run time of 6 hours. If this condition is reached, the control will terminate the run cycle, continue through the proper sequence of operations, and then immediately enter the system check and pre-purge cycles to prepare for reignition.
9. Once the run cycle has terminated, the redundant safety valve will close, the modulating valve will return to its set position, and the draft inducer will ramp up to its "light-off" setting for a 45 second post-purge cycle.
10. After the conclusion of the post-purge, the control will enter the "OFF" state. While safety devices are still monitored, all system outputs are de-energized.

### VB1287 BPP Staged Control - Standard and Split Manifolds

1. A call for heat is initiated by the rooftop unit control through a digital Modbus signal. Refrigeration Only control packages may differ.
2. The VB1287 control will then go through a system check to ensure that the high temperature limit and rollout switches are closed, the air pressure switch is open, and the modulating valve is positioned correctly.
3. The staged control will then enter the pre-purge cycle, where the inducer will run at the programmed purge pressure. During this cycle, the control will look for the air pressure switch to close and open at the correct settings.
4. Once the system check and pre-purge cycles are complete, the control will enter the ignition cycle.
  - a. The inducer will go to its "light off" setting (usually high speed).
  - b. The DSI ignition module will be energized and the spark ignitor will activate.
  - c. The control valve and any redundant safety valves will open, allowing gas flow.
  - d. The burners will ignite and the VB1287 control will receive a signal from the flame sensor.
  - e. The spark ignitor will remain active for the duration of the ignition cycle, regardless of flame status.
5. If flame is not established during the ignition cycle, the control will repeat the pre-purge and ignition cycles up to three times. After three failed ignition attempts, the board will enter a 1 hour lockout.
6. Once flame has been established, the control will enter a

warm-up period to ensure flame stabilization and reduce condensation in the heat exchanger.

7. After the warm-up period, the control will enter the run cycle. If equipped with a 2-stage valve, during the run cycle the burner firing rate is determined by the heat demand received by the control via a Modbus signal. Two firing stages, High or Low, are available.

**NOTE:** If the control is paired with a split manifold, steps 1 through 6 pertain to the primary burners. Once the control exits the warm-up period and the firing rate is dictated by the rooftop control, the control will step the primary burners High or Low (if equipped with a 2-stage valve) and ignite the secondary burners based on the demand for heat.

8. The run cycle will continue until any of the following conditions are met:
  - a. The call for heat is terminated.
  - b. Any of the safety devices (high limit, air pressure, rollout, etc.) are triggered.
  - c. The control reaches its maximum run time of 6 hours. If this condition is reached, the control will terminate the run cycle, continue through the proper sequence of operations, and then immediately enter the system check and pre-purge cycles to prepare for reignition.
9. Once the run cycle has terminated, any redundant safety valves present will close, the staged control valve will close, and the draft inducer will ramp up to its "light-off" setting for a 45 second post-purge cycle.
10. After the conclusion of the post-purge, the control will enter the "OFF" state. All system outputs are de-energized but all safety devices are still monitored.

## Electric Furnace Sequence of Operation

The electric heater should be activated as the first source of heat and modulate to maintain the heating discharge air temperature setpoint (for heating) or the cooling discharge air temperature setpoint (for minimum discharge air temperatures). If the electric heater reaches 100% capacity and cannot meet the discharge air setpoint, the electric heater is shut off and the gas furnace is brought on at minimum fire. The electric heater continues to run at 100% until the furnace command has been given for 60 seconds. If the gas furnace reaches minimum fire for a heating stage timer and over shoots the heating discharge air temperature setpoint, the gas furnace is shut off and the electric heater is activated and modulated to maintain the discharge air temperature setpoint.

## Refrigeration Only Controls (ROC)

When the unit is equipped with Refrigeration Only Controls (ROC), the field-provided controller must send a 0-10V signal to the MicroTech controller. Refer to the as-built wiring diagrams provided with your unit for specific configurations and control signal landing locations. The diagrams beginning on [page 147](#) may be used as a general reference.

**NOTE:** The MicroTech unit controller will only operate the furnace if airflow is also called for. In addition, the controller will delay fan shut-off until the furnace has been turned off for a predetermined time.

## ROC Staging - Natural Gas

**Table 48: 200 MBH Staging Information (Natural Gas)**

200 MBH Modulating - 5:1	Input Voltage Signal (VDC)	Modulating Section	Engaged Furnace Sections	Total Heat Capacity (%)	Total Heat Input (MBH)
	0.00 - 0.20	0%	-	0%	0
	0.20 - 2.00	20%	M	20%	40
	2.00 - 10.00	20% - 100%	M	20% - 100%	40 - 200
	10.00+	100%	M	100%	200
200 MBH 2-Stage	Input Voltage Signal (VDC)	Staged Section S1	Staged Section S2	Total Heat Capacity (%)	Total Heat Input (MBH)
	0 - 0.20	Off	-	0%	0
	0.20 - 9.50	Low	-	55%	110
	9.50+	High	-	100%	200

**NOTE:** "Modulating Section" refers to only section M if standard sections are used, but sections M & S1 if split sections are used. Refer to the diagrams beginning on [page 147](#) for section location and identification.

**Table 49: 400 MBH Staging Information (Natural Gas)**

400 MBH Modulating - 5:1	Input Voltage Signal (VDC)	Modulating Section	Engaged Furnace Sections	Total Heat Capacity (%)	Total Heat Input (MBH)
	0.00 - 0.20	0%	-	0%	0
	0.20 - 2.00	20%	M	20%	80
	2.00 - 10.00	20% - 100%	M	20% - 100%	80 - 400
	10.00+	100%	M	100%	400
400 MBH Modulating - 10:1	Input Voltage Signal (VDC)	Modulating Section	Engaged Furnace Sections	Total Heat Capacity (%)	Total Heat Input (MBH)
	0.00 - 0.20	0%	-	0%	0
	0.20 - 1.00	10%	M, S1	10%	40
	1.00 - 10.00	10% - 100%	M, S1	10% - 100%	40 - 400
	10.00+	100%	M, S1	100%	400
400 MBH 2-Stage	Input Voltage Signal (VDC)	Staged Section S1	Staged Section S2	Total Heat Capacity (%)	Total Heat Input (MBH)
	0 - 0.20	Off	-	0%	0
	0.2 - 9.50	Low	-	55%	220
	9.50+	High	-	100%	400

**NOTE:** "Modulating Section" refers to only section M if standard sections are used, but sections M & S1 if split sections are used. Refer to the diagrams beginning on [page 147](#) for section location and identification.

**Table 50: 600 MBH Staging Information (Natural Gas)**

600 MBH Modulating - 5:1	Input Voltage Signal (VDC)	Modulating Section	Engaged Furnace Sections	Total Heat Capacity (%)	Total Heat Input (MBH)
	0.00 - 0.20	0%	-	0%	0
0.20 - 2.00	20%	M, S1	20%	120	
2.00 - 10.00	20% - 100%	M, S1	20% - 100%	120 - 600	
10.00+	100%	M, S1	100%	600	
600 MBH Modulating - 10:1	Input Voltage Signal (VDC)	Modulating Section	Engaged Furnace Sections	Total Heat Capacity (%)	Total Heat Input (MBH)
	0.00 - 0.20	0%	-	0%	0
0.20 - 1.00	10%	M, S1	10%	60	
1.00 - 10.00	10% - 100%	M, S1	10% - 100%	60 - 600	
10.00+	100%	M, S1	100%	600	
600 MBH Modulating - 20:1	Input Voltage Signal (VDC)	Modulating Section	Engaged Furnace Sections	Total Heat Capacity (%)	Total Heat Input (MBH)
	0.00 - 0.20	0%	-	0%	0
0.20 - 0.50	10%	M, S1	5%	30	
0.50 - 5.00	10% - 100%	M, S1	5% - 50%	30 - 300	
5.00 - 5.50	10%	M, S1, S2	55%	330	
5.50 - 10.00	10% - 100%	M, S1, S2	55% - 100%	330 - 600	
10.00+	100%	M, S1, S2	100%	600	
600 MBH 2-Stage	Input Voltage Signal (VDC)	Staged Section S1	Staged Section S2	Total Heat Capacity (%)	Total Heat Input (MBH)
	0 - 0.20	Off	Off	0%	0
0.2 - 9.50	On	Off	50%	300	
9.50+	On	On	100%	600	
600 MBH 4-Stage	Input Voltage Signal (VDC)	Staged Section S1	Staged Section S2	Total Heat Capacity (%)	Total Heat Input (MBH)
	0 - 0.20	Off	Off	0%	0
0.20 - 5.00	Low	Off	27.5%	165	
5.00 - 7.50	Low	Low	55%	330	
7.50 - 9.50	High	Low	77.5%	465	
9.50+	High	High	100%	600	

**NOTE:** “Modulating Section” refers to only section M if standard sections are used, but sections M & S1 if split sections are used. Refer to the diagrams beginning on [page 147](#) for section location and identification.

**Table 51: 800 MBH Staging Information (Natural Gas)**

800 MBH Modulating - 10:1	Input Voltage Signal (VDC)	Modulating Section	Engaged Furnace Sections	Total Heat Capacity (%)	Total Heat Input (MBH)
	0.00 - 0.20	0%	-	0%	0
0.20 - 1.00	20%	M	10%	80	
1.00 - 5.00	20% - 100%	M	10% - 50%	80 - 400	
5.00 - 6.00	20%	M, S1	60%	480	
6.00 - 10.00	20% - 100%	M, S1	60% - 100%	480 - 800	
10.00+	100%	M, S1	100%	800	
800 MBH Modulating - 20:1	Input Voltage Signal (VDC)	Modulating Section	Engaged Furnace Sections	Total Heat Capacity (%)	Total Heat Input (MBH)
	0.00 - 0.20	0%	-	0%	0
0.20 - 0.50	10%	M, S1	5%	40	
0.50 - 5.00	10% - 100%	M, S1	5% - 50%	40 - 400	
5.00 - 5.50	10%	M, S1, S2	55%	440	
5.50 - 10.00	10% - 100%	M, S1, S2	55% - 100%	440 - 800	
10.00+	100%	M, S1, S2	100%	800	

**NOTE:** “Modulating Section” refers to only section M if standard sections are used, but sections M & S1 if split sections are used. Refer to the diagrams beginning on [page 147](#) for section location and identification.

**Table 52: 1125 MBH Staging Information (Natural Gas)**

1125 MBH Modulating - 10:1	Input Voltage Signal (VDC)	Modulating Section	Engaged Furnace Sections	Total Heat Capacity (%)	Total Heat Input (MBH)
	0.00 - 0.20	0%	-	0%	0
	0.20 - 1.00	10%	M, S1	10%	113
	1.00 - 5.00	10% - 100%	M, S1	10% - 50%	113 - 563
	5.00 - 5.50	50%	M, S1, S2	55%	619
	5.50 - 7.50	50% - 100%	M, S1, S2	55% - 75%	619 - 844
	7.50 - 8.00	50%	M, S1, S2, S3	80%	900
	8.00 - 10.00	50% - 100%	M, S1, S2, S3	80% - 100%	900 - 1125
	10.00+	100%	M, S1, S2, S3	100%	1125

1125 MBH Modulating - 20:1	Input Voltage Signal (VDC)	Modulating Section	Engaged Furnace Sections	Total Heat Capacity (%)	Total Heat Input (MBH)
	0.00 - 0.20	0%	-	0%	0
	0.20 - 0.50	5%	M, S1	5%	56
	0.50 - 5.00	5% - 100%	M, S1	5% - 50%	56 - 563
	5.00 - 5.25	50%	M, S1, S2	52.5%	591
	5.25 - 7.50	50% - 100%	M, S1, S2	52.5% - 75%	591 - 844
	7.50 - 7.75	50%	M, S1, S2, S3	77.5%	872
	7.75 - 10.00	50% - 100%	M, S1, S2, S3	77.5% - 100%	872 - 1125
	10.00+	100%	M, S1, S2, S3	100%	1125

**NOTE:** “Modulating Section” refers to only section M if standard sections are used, but sections M & S1 if split sections are used. Refer to the diagrams beginning on [page 147](#) for section location and identification.

**Table 53: 1500 MBH Staging Information (Natural Gas)**

1500 MBH Modulating - 10:1	Input Voltage Signal (VDC)	Modulating Section	Engaged Furnace Sections	Total Heat Capacity (%)	Total Heat Input (MBH)
	0.00 - 0.20	0%	-	0%	0
	0.20 - 1.00	40%	M	10%	150
	1.00 - 2.50	40% - 100%	M	10% - 25%	150 - 375
	2.50 - 3.50	40%	M, S1	35%	525
	3.50 - 5.00	40% - 100%	M, S1	35% - 50%	525 - 750
	5.00 - 6.00	40%	M, S1, S2	60%	900
	6.00 - 7.50	40% - 100%	M, S1, S2	60% - 75%	900 - 1125
	7.50 - 8.50	40%	M, S1, S2, S3	85%	1275
	8.50 - 10.00	40% - 100%	M, S1, S2, S3	85% - 100%	1275 - 1500
10.00+	100%	M, S1, S2, S3	100%	1500	

1500 MBH Modulating - 20:1	Input Voltage Signal (VDC)	Modulating Section	Engaged Furnace Sections	Total Heat Capacity (%)	Total Heat Input (MBH)
	0.00 - 0.20	0%	-	0%	0
	0.20 - 0.50	20%	M	5%	75
	0.50 - 2.50	20% - 100%	M	5% - 25%	75 - 375
	2.50 - 3.00	20%	M, S1	30%	450
	3.00 - 5.00	20% - 100%	M, S1	30% - 50%	450 - 750
	5.00 - 5.50	20%	M, S1, S2	55%	825
	5.50 - 7.50	20% - 100%	M, S1, S2	55% - 75%	825 - 1125
	7.50 - 8.00	20%	M, S1, S2, S3	80%	1200
	8.00 - 10.00	20% - 100%	M, S1, S2, S3	80% - 100%	1200 - 1500
10.00+	100%	M, S1, S2, S3	100%	1500	

**NOTE:** “Modulating Section” refers to only section M if standard sections are used, but sections M & S1 if split sections are used. Refer to the diagrams beginning on [page 147](#) for section location and identification.

## ROC Staging - Propane Gas

**Table 54: 200 MBH Staging Information (Propane Gas)**

200 MBH Modulating - 5:1	Input Voltage Signal (VDC)	Modulating Section	Engaged Furnace Sections	Total Heat Capacity (%)	Total Heat Input (MBH)
	0.00 - 0.20	0%	-	0%	0
	0.20 - 2.00	20%	M	20%	40
	2.00 - 10.00	20%-100%	M	20%-100%	40-200
	10.00+	100%	M	100%	200
200 MBH 2-Stage	Input Voltage Signal (VDC)	Staged Section S1	Staged Section S2	Total Heat Capacity (%)	Total Heat Input (MBH)
	0 - 0.20	Off	-	0%	0
	0.20 - 9.50	Low	-	55%	110
	9.50+	High	-	100%	200

**NOTE:** "Modulating Section" refers to only section M if standard sections are used, but sections M & S1 if split sections are used. Refer to the diagrams beginning on [page 147](#) for section location and identification.

**Table 55: 400 MBH Staging Information (Propane Gas)**

400 MBH Modulating - 5:1	Input Voltage Signal (VDC)	Modulating Section	Engaged Furnace Sections	Total Heat Capacity (%)	Total Heat Input (MBH)
	0.00 - 0.20	0%	-	0%	0
	0.20 - 2.00	20%	M	20%	80
	2.00 - 10.00	20%-100%	M	20%-100%	80-400
	10.00+	100%	M	100%	400
400 MBH Modulating - 10:1	Input Voltage Signal (VDC)	Modulating Section	Engaged Furnace Sections	Total Heat Capacity (%)	Total Heat Input (MBH)
	0.00 - 0.20	0%	-	0%	0
	0.20 - 1.00	10%	M, S1	10%	40
	1.00 - 10.00	10%-100%	M, S1	10%-100%	40-400
	10.00+	100%	M, S1	100%	400
400 MBH 2-Stage	Input Voltage Signal (VDC)	Staged Section S1	Staged Section S2	Total Heat Capacity (%)	Total Heat Input (MBH)
	0 - 0.20	Off	-	0%	0
	0.2 - 9.50	Low	-	55%	220
	9.50+	High	-	100%	400

**NOTE:** "Modulating Section" refers to only section M if standard sections are used, but sections M & S1 if split sections are used. Refer to the diagrams beginning on [page 147](#) for section location and identification.

**Table 56: 600 MBH Staging Information (Propane Gas)**

600 MBH Modulating - 5:1	Input Voltage Signal (VDC)	Modulating Section	Engaged Furnace Sections	Total Heat Capacity (%)	Total Heat Input (MBH)
	0.00 - 0.20	0%	-	0%	0
	0.20 - 2.00	20%	M, S1	20%	120
	2.00 - 10.00	20%-100%	M, S1	20%-100%	120-600
	10.00+	100%	M, S1	100%	600
600 MBH Modulating - 10:1	Input Voltage Signal (VDC)	Modulating Section	Engaged Furnace Sections	Total Heat Capacity (%)	Total Heat Input (MBH)
	0.00 - 0.20	0%	-	0%	0
	0.20 - 1.00	10%	M, S1	10%	60
	1.00 - 10.00	10%-100%	M, S1	10%-100%	60-600
	10.00+	100%	M, S1	100%	600
600 MBH Modulating - 20:1	Input Voltage Signal (VDC)	Modulating Section	Engaged Furnace Sections	Total Heat Capacity (%)	Total Heat Input (MBH)
	<b>0.00 - 0.20</b>	0%	-	0%	0
	0.20 - 0.50	10%	M, S1	5%	30
	0.50 - 5.00	10% - 100%	M, S1	5% - 50%	30 - 300
	5.00 - 5.50	10%	M, S1, S2	55%	330
	5.50 - 10.00	10% - 100%	M, S1, S2	55% - 100%	330 - 600
	10.00+	100%	M, S1, S2	100%	600
600 MBH 2-Stage	Input Voltage Signal (VDC)	Staged Section S1	Staged Section S2	Total Heat Capacity (%)	Total Heat Input (MBH)
	0 - 0.20	Off	Off	0%	0
	0.2 - 9.50	On	Off	50%	300
	9.50+	On	On	100%	600
600 MBH 4-Stage	Input Voltage Signal (VDC)	Staged Section S1	Staged Section S2	Total Heat Capacity (%)	Total Heat Input (MBH)
	0 - 0.20	Off	Off	0%	0
	0.20 - 5.00	Low	Off	27.5%	165
	5.00 - 7.50	Low	Low	55%	330
	7.50 - 9.50	High	Low	77.5%	465
	9.50+	High	High	100%	600

**NOTE:** "Modulating Section" refers to only section M if standard sections are used, but sections M & S1 if split sections are used. Refer to the diagrams beginning on [page 147](#) for section location and identification.

**Table 57: 800 MBH Staging Information (Propane Gas)**

800 MBH Modulating - 6:1	Input Voltage Signal (VDC)	Modulating Section	Engaged Furnace Sections	Total Heat Capacity (%)	Total Heat Input (MBH)
	0.00 - 0.20	0%	-	0%	0
	0.20 - 1.00	33%	M	17%	133
	1.00 - 5.00	33%-100%	M	17%-50%	133-400
	5.00 - 6.00	33%	M, S1	67%	533
	6.00 - 10.00	33%-100%	M, S1	67%-100%	533-800
	10.00+	100%	M, S1	100%	800
800 MBH Modulating - 12:1	Input Voltage Signal (VDC)	Modulating Section	Engaged Furnace Sections	Total Heat Capacity (%)	Total Heat Input (MBH)
	0.00 - 0.20	0%	-	0%	0
	0.20 - 0.50	17%	M, S1	8%	67
	0.50 - 5.00	17%-100%	M, S1	8%-50%	67-400
	5.00 - 5.50	17%	M, S1, S2	58%	467
	5.50 - 10.00	17%-100%	M, S1, S2	58%-100%	467-800
	10.00+	100%	M, S1, S2	100%	800

**NOTE:** "Modulating Section" refers to only section M if standard sections are used, but sections M & S1 if split sections are used. Refer to the diagrams beginning on [page 147](#) for section location and identification.

**Table 58: 1125 MBH Staging Information (Propane Gas)**

1125 MBH Modulating - 6:1	Input Voltage Signal (VDC)	Modulating Section	Engaged Furnace Sections	Total Heat Capacity (%)	Total Heat Input (MBH)
	0.00 - 0.20	0%	-	0%	0
	0.20 - 1.00	33%	M, S1	17%	188
	1.00 - 5.00	33%-100%	M, S1	17%-50%	188-563
	5.00 - 5.50	50%	M, S1, S2	55%	619
	5.50 - 7.50	50%-100%	M, S1, S2	55%-75%	619-844
	7.50 - 8.00	50%	M, S1, S2, S3	80%	900
	8.00 - 10.00	50%-100%	M, S1, S2, S3	80%-100%	900-1125
	10.00+	100%	M, S1, S2, S3	100%	1125

1125 MBH Modulating - 12:1	Input Voltage Signal (VDC)	Modulating Section	Engaged Furnace Sections	Total Heat Capacity (%)	Total Heat Input (MBH)
	0.00 - 0.20	0%	-	0%	0
	0.20 - 0.50	17%	M, S1	8%	94
	0.50 - 5.00	17%-100%	M, S1	8%-50%	94-563
	5.00 - 5.25	50%	M, S1, S2	52.5%	591
	5.25 - 7.50	50%-100%	M, S1, S2	52.5%-75%	591-844
	7.50 - 7.75	50%	M, S1, S2, S3	77.5%	872
	7.75 - 10.00	50%-100%	M, S1, S2, S3	77.5%-100%	872-1125
	10.00+	100%	M, S1, S2, S3	100%	1125

**NOTE:** “Modulating Section” refers to only section M if standard sections are used, but sections M & S1 if split sections are used. Refer to the diagrams beginning on [page 147](#) for section location and identification.

**Table 59: 1500 MBH Staging Information (Propane Gas)**

1500 MBH Modulating - 6:1	Input Voltage Signal (VDC)	Modulating Section	Engaged Furnace Sections	Total Heat Capacity (%)	Total Heat Input (MBH)
	0.00 - 0.20	0%	-	0%	0
	0.20 - 1.00	67%	M	17%	0
	1.00 - 2.50	67%-100%	M	17%-25%	250-375
	2.50 - 3.50	67%	M, S1	42%	0
	3.50 - 5.00	67%-100%	M, S1	42%-50%	625-750
	5.00 - 6.00	67%	M, S1, S2	67%	0
	6.00 - 7.50	67%-100%	M, S1, S2	67%-75%	1000-1125
	7.50 - 8.50	67%	M, S1, S2, S3	92%	0
	8.50 - 10.00	67%-100%	M, S1, S2, S3	92%-100%	1375-1500
10.00+	100%	M, S1, S2, S3	100%	1500	

1500 MBH Modulating - 12:1	Input Voltage Signal (VDC)	Modulating Section	Engaged Furnace Sections	Total Heat Capacity (%)	Total Heat Input (MBH)
	0.00 - 0.20	0%	-	0%	0
	0.20 - 0.50	33%	M	8%	0
	0.50 - 2.50	33%-100%	M	8%-25%	125-375
	2.50 - 3.00	33%	M, S1	33%	0
	3.00 - 5.00	33%-100%	M, S1	33%-50%	500-750
	5.00 - 5.50	33%	M, S1, S2	58%	0
	5.50 - 7.50	33%-100%	M, S1, S2	58%-75%	875-1125
	7.50 - 8.00	33%	M, S1, S2, S3	83%	0
	8.00 - 10.00	33%-100%	M, S1, S2, S3	83%-100%	1250-1500
10.00+	100%	M, S1, S2, S3	100%	1500	

**NOTE:** “Modulating Section” refers to only section M if standard sections are used, but sections M & S1 if split sections are used. Refer to the diagrams beginning on [page 147](#) for section location and identification.

## Altitude Conversion

### WARNING

This unit is equipped at the factory for use with either natural gas or propane, as specified on the furnace data plate. Conversion requires a special kit supplied by Daikin Applied Parts. Failure to use the proper conversion kit can cause a fire, carbon monoxide poisoning, or explosion which may result in personal injury, property damage, or death.

### WARNING

Installation and maintenance must be performed only by qualified personnel who are trained and experienced with this type of equipment and familiar with local codes and regulations.

For elevations up to 2000 feet, rating plate input ratings apply.

For altitudes listed in [Table 60](#), use associated altitude conversion kit.

For altitudes above 7000 feet, consult Daikin Applied Parts for required conversion kit.

### NOTICE

The furnace is not recommended for installation at altitudes above 11,000 feet.

**NOTE:** If the fuel source has been derated for altitude by the local utility provider, then a conversion kit is not required.

See tables below for part numbers. Contact local gas supplier to confirm gas heating value has been devalued for applicable elevations.

**Table 60: Furnace Identifications for Altitude**

Elevation (ft)	Daikin Applied Part Number
<b>200 MBH (58.6 kW)</b>	
2000–2999	N/A
3000–3999	910333674
4000–4999	910333676
5000–5999	910333677
6000–6999	910333679
<b>400 MBH (117.2 kW)</b>	
2000–2999	N/A
3000–3999	910333680
4000–4999	910333682
5000–5999	910333683
6000–6999	910333684
<b>600 MBH (175.8 kW)</b>	
2000–2999	N/A
3000–3999	910333685
4000–4999	910333686
5000–5999	910333687
6000–6999	910333688
<b>800 MBH (234.5 kW)</b>	
2000–2999	N/A
3000–3999	910333689
4000–4999	910333690
5000–5999	910333691
6000–6999	910333692
<b>1125 MBH (329.7 kW)</b>	
2000–2999	N/A
3000–3999	910333693
4000–4999	910333694
5000–5999	910333695
6000–6999	910333696
<b>1500 MBH (439.6 kW)</b>	
2000–2999	(2x) 910452264
3000–3999	(2x) 910452266
4000–4999	(2x) 910452268
5000–5999	(2x) 910452270
6000–6999	(2x) 910452272

## Gas Conversion

Field gas conversion kits can be obtained through Daikin Applied Parts for converting a furnace, or furnaces, to an alternate fuel. The conversion to be performed by only trained experienced and qualified personnel who are knowledgeable of all pertinent codes and regulations.

**Table 61: Furnace Natural Gas to LP Gas Conversion Kit**

Natural Gas to LP Gas Conversion	
Furnace Size in MBH (kW)	Daikin Applied Part Number
<b>Staged</b>	
200 (58.6)	910333748
400 (117.2)	910333749
600 (175.8)	910333750
<b>Modulating</b>	
200 (58.6)	910333752
400 (117.2) Low-Mod	910333753
400 (117.2) High-Mod	910333754
600 (175.8) Low-Mod	910333755
600 (175.8) High-Mod	910333756
800 (234.5) Low-Mod	910333757
800 (234.5) High-Mod	910333759
1125 (329.7) Low-Mod	910333760
1125 (329.7) High-Mod	910333761
1500 (439.6) Low-Mod	910452233, 910452234
1500 (439.6) High-Mod	910452233, 910452235

**Table 62: Furnace LP Gas to Natural Gas Conversion Kit**

LP Gas to Natural Gas Conversion	
Furnace Size in MBH (kW)	Daikin Applied Part Number
<b>Staged</b>	
200 (58.6)	910333648
400 (117.2)	910333650
600 (175.8)	910333653
<b>Modulating</b>	
200 (58.6)	910333654
400 (117.2) Low-Mod	910333655
400 (117.2) High-Mod	910333663
600 (175.8) Low-Mod	910333664
600 (175.8) High-Mod	910333665
800 (234.5) Low-Mod	910333667
800 (234.5) High-Mod	910333670
1125 (329.7) Low-Mod	910333671
1125 (329.7) High-Mod	910333672
1500 (439.6) Low-Mod	910452259, 910452260
1500 (439.6) High-Mod	910452259, 910452261

## Operations

### WARNING

Overheating or failure of the gas supply to shut off can cause equipment damage, severe personal injury, or death. Turn off the manual gas valve to the appliance before shutting off the electrical supply.

### WARNING

Testing for gas leaks with an open flame can cause an explosion or fire resulting in property damage, personal injury, or death. Use a commercially available soap solution made specifically for the detection of leaks to check all connections.

### CAUTION

Hot surface hazard. If the furnace has been operating prior to service, allow chimney flue, gas heat exchanger, and combustion manifold to cool before servicing. Failure to allow hot surfaces to cool may result in personal injury.

### Start-Up Responsibility

The start-up organization is responsible for determining that the furnace, as installed and applied, will operate within the limits specified on the furnace rating plate.

1. The furnace must not operate at insufficient airflow or temperature rise greater than specified (refer to [Table 61 on page 172](#) and [Table 62](#)). On variable air volume systems it must be determined that the furnace will not be operated if or when system airflow is reduced below the specified minimum airflow.
2. It must be established that the gas supply is within the proper pressure range (refer to [Table 61 on page 172](#) and [Table 62](#)).

**Start-up and service of this equipment must be performed by trained and qualified technicians.** It is highly recommended that the initial start-up and future service be performed by Daikin Applied trained technicians who are familiar with working on live equipment. A representative of the owner or the operator of the equipment should be present during start-up to receive instructions in the operation, care, and adjustment of the unit.

### Before Start-Up

1. Notify inspectors or representatives who may be required to be present during start-up of gas fuel equipment. These could include the gas utility company, city gas inspectors, heating inspectors, etc.
2. Review the equipment and service literature and become familiar with the location and purpose of the furnace controls. Determine where the gas and power can be turned OFF at the unit and before the unit.
3. Determine that power is connected to the unit and available.
4. Determine that the gas piping, meter, and service regulator have been installed, tested, and meet the equipment requirements.
5. Ensure that all required equipment and instruments are available for startup.

### Preliminary Start-Up

1. Close gas main.
2. Check the combustion inducer fan wheel for binding, rubbing, or loose setscrews.
3. Confirm supply voltage.
4. Purge the gas lines.
5. Leak check. Using a rich soap-water mixture and a brush, check the gas lines for leaks. Correct all leaks before starting furnace.

## Service

The furnace DDC controller has diagnostic information for troubleshooting the furnace operation. Reference [page 163](#) as applicable for information on VB1285 and VB1287.

## Maintenance

### WARNING

Installation and maintenance must be performed only by qualified personnel who are trained and experienced with this type of equipment and familiar with local codes and regulations.

### WARNING

Improper installation, adjustment, alteration, service, or maintenance can cause severe personal injury or death. Read and understand this installation and maintenance manual thoroughly before installing or servicing this equipment.

### WARNING

#### Electrical shock and moving machinery hazard.

LOCKOUT/TAGOUT all power sources prior to servicing the equipment. Electrical shock can cause injury, death, and property damage. More than one disconnect may be required to de-energize unit. All start-up and service work must be performed only by trained, experienced technicians familiar with this type of equipment. Read and follow the MicroTech controller manual before operating or servicing. Bond the equipment frame to the building's electrical ground through the grounding terminal or other approved means.

### CAUTION

Hot surface hazard. May cause minor to moderate personal injury. Allow burner assembly and chimney flues to cool before servicing equipment.

### CAUTION

Prevent snow levels from blocking airflow into the furnace vestibule and combustion air inlet. Ensure snow does not accumulate and interfere with the operation of electronics within the vestibule.

Planned maintenance is the best way to avoid unnecessary expense and inconvenience. Inspect the heating system at regular intervals by a trained and experienced service technician. The following service intervals are typical for average situations but should be adjusted per site conditions.

Fuel pressure and control settings should be made only by trained and qualified personnel.

Always replace covers on burner controls and boxes as the electrical contacts. Perform maintenance of controls, gas valves, and other components in accordance with the furnace module instruction manual.

### Monthly

Check cabinet air filters and replace if dirty. After heavy snowfall verify that combustion air intakes are not blocked by snow. Periodically check during periods of snow accumulation as drifting may also lead to combustion air intake blockage.

### Twice Yearly

1. **Combustion Air:** Check combustion inducer fan for dirt buildup and lint. Check combustion air intake louvers and flue box/vent for accumulation of dirt and debris.
2. **Cleaning:** Inspect and clean flue tubes and combustion chamber. Keep burner vestibule clean. Dirt and debris can result in poor combustion and lower efficiency.

### Yearly

1. **Debris:** Check vent terminal screens for blockages and accumulation.
2. **Heater and the Venting System:** Shall be inspected once a year by a qualified service agency.
3. **Gas Train:** Check all valves, piping and connections for leakage with a rich soap solution or UL 913 combustible gas leak detector. Any bubbling is considered a leak and must be eliminated. Inspect and clean flame rod, ignition electrode, and burner manifold.
4. **Condensate Pan and Drain:** Remove any debris that may have accumulated in the drain pan and drain.

### Special Weather Events

1. After heavy snowfall, verify that combustion air intakes are not blocked by snow.
2. Periodically check during periods of snow accumulation as drifting may also lead to combustion air intake blockage.



Figure 245: 600 MBH (2-Stage)

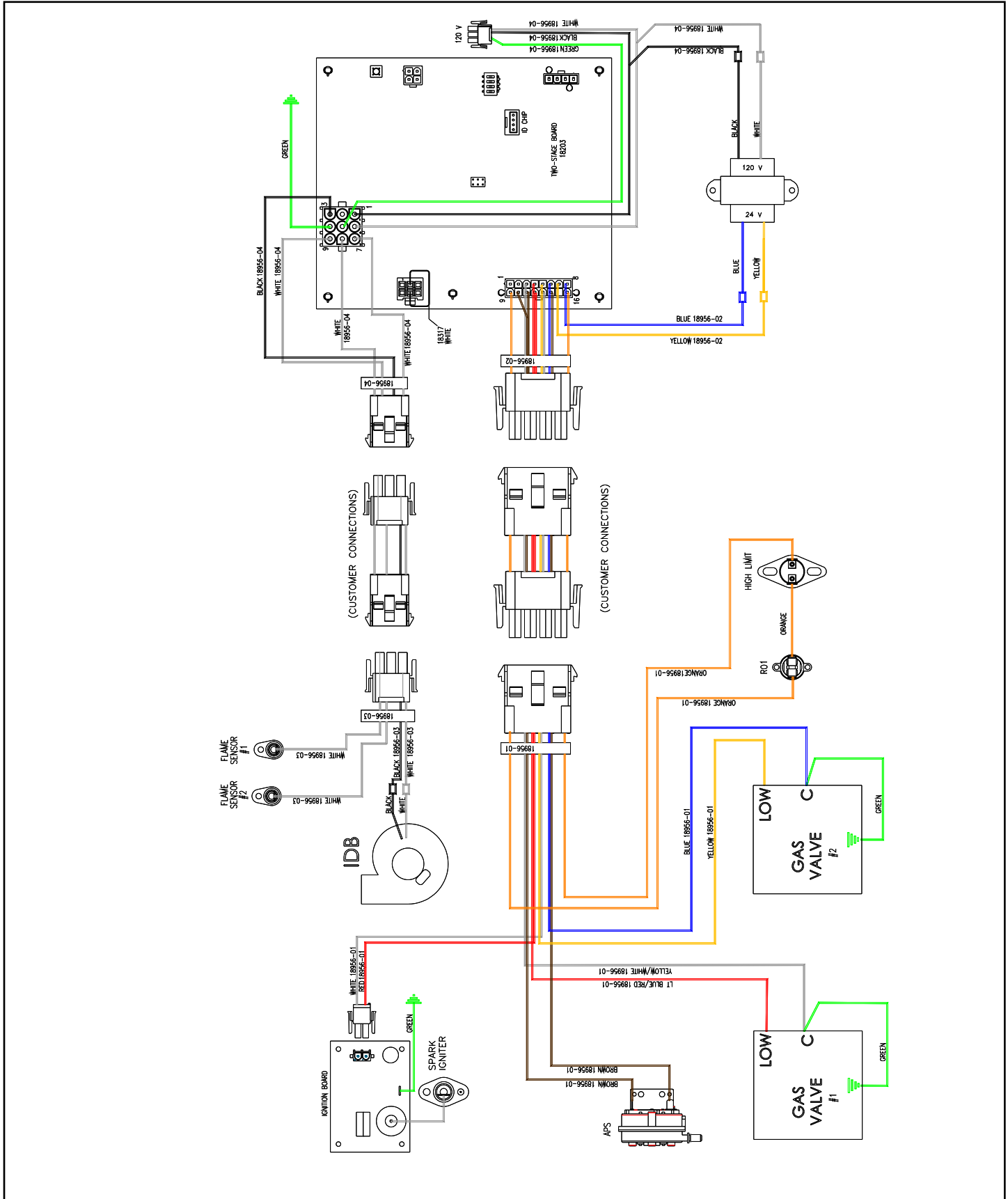


Figure 246: 600 MBH (4-Stage)

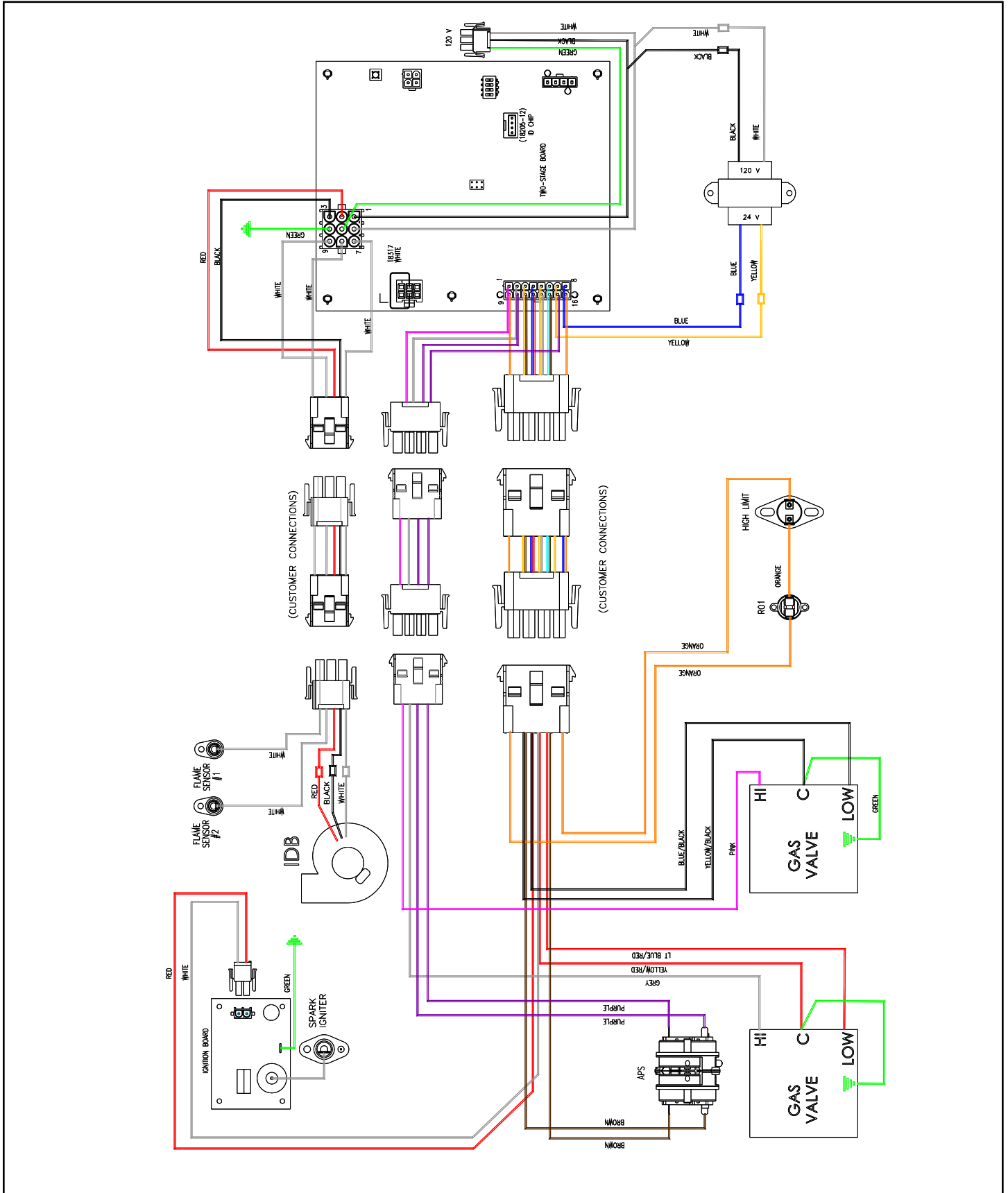


Figure 247: 200 and 400 MBH (5:1 Modulation)

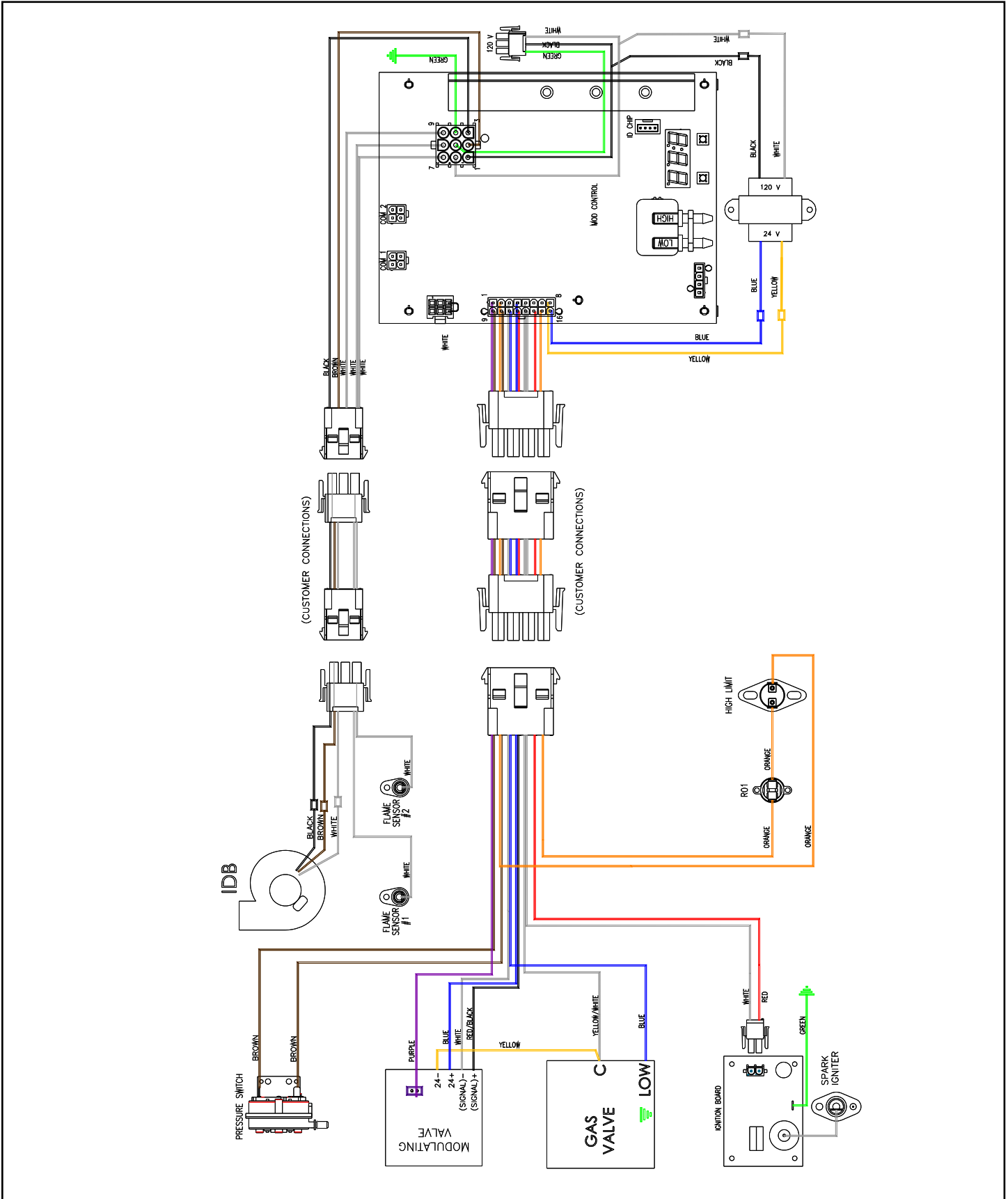


Figure 248: 600 MBH (5:1 Modulation), 400 MBH and 600 MBH (10:1 Modulation)

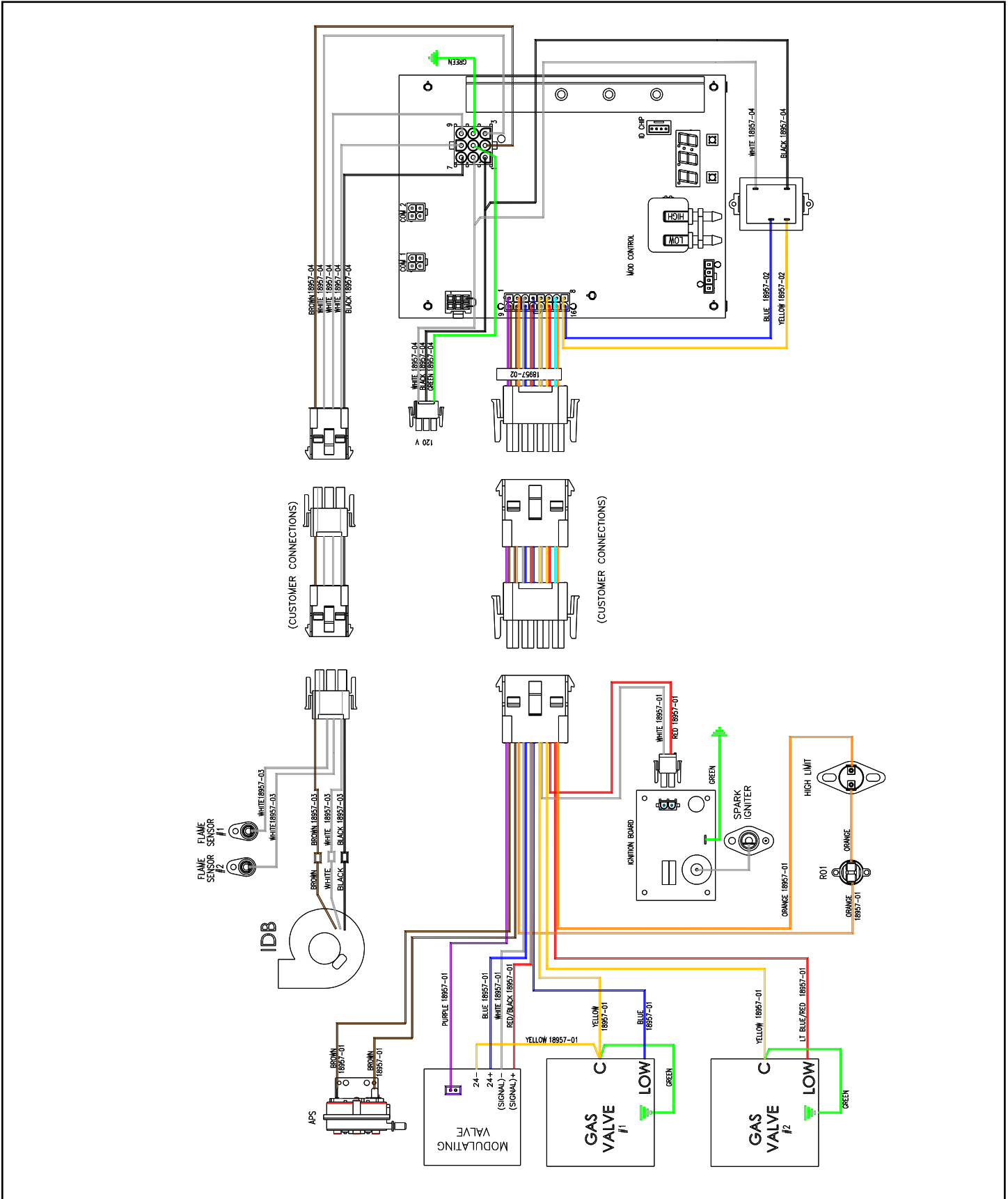




Figure 250: 800 MBH (20:1 and 12:1 Modulation)



Figure 251: 1125 MBH (10:1 and 6:1 Modulation), 1125 MBH (20:1 and 12:1 Modulation)

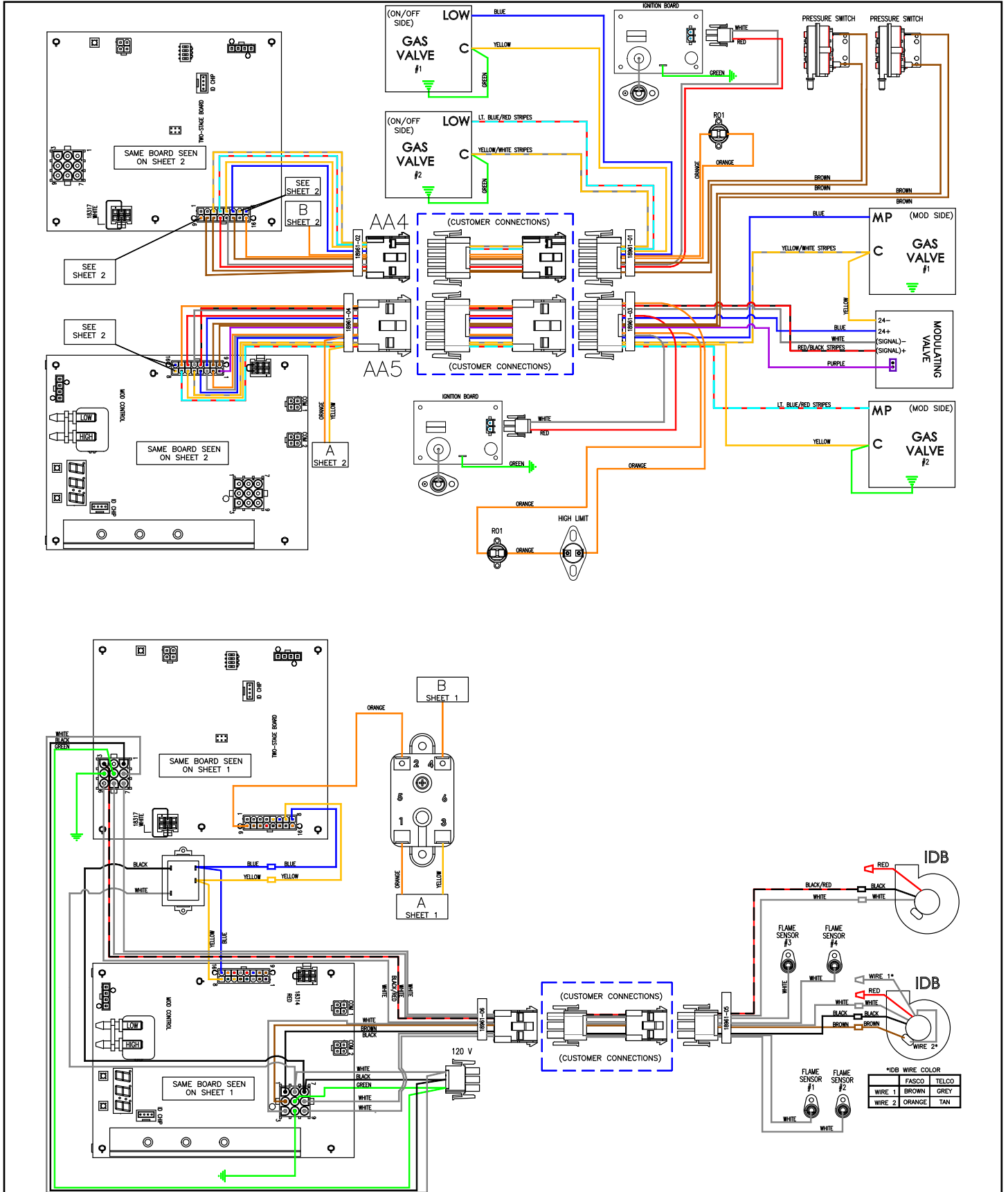


Figure 252: 1500 MBH (6:1, 10:1, 12:1, 20:1 Modulation) Modulating Furnace

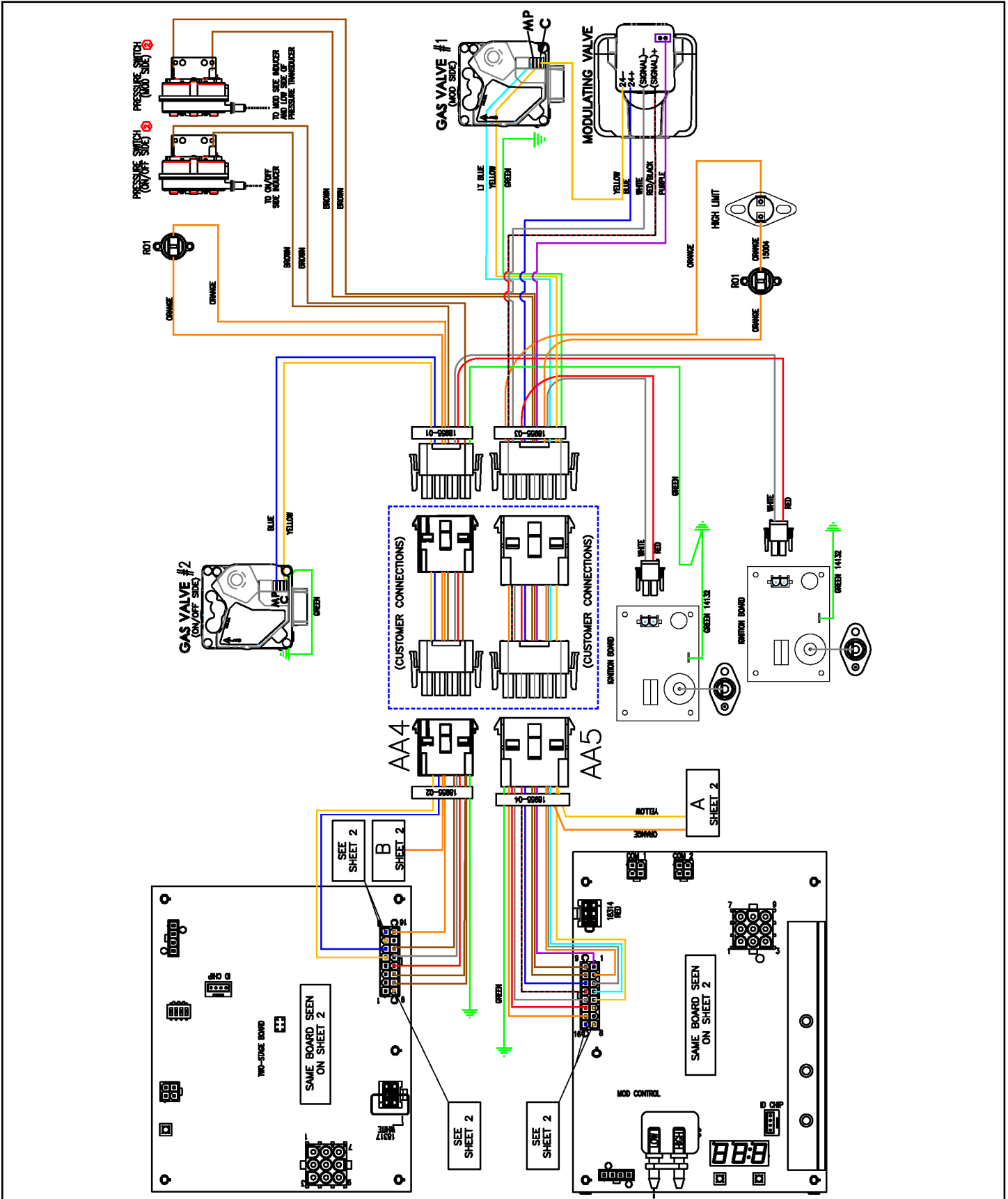


Figure 253: 1500 MBH (6:1, 10:1, 12:1, 20:1 Modulation) Modulating Furnace (continued)

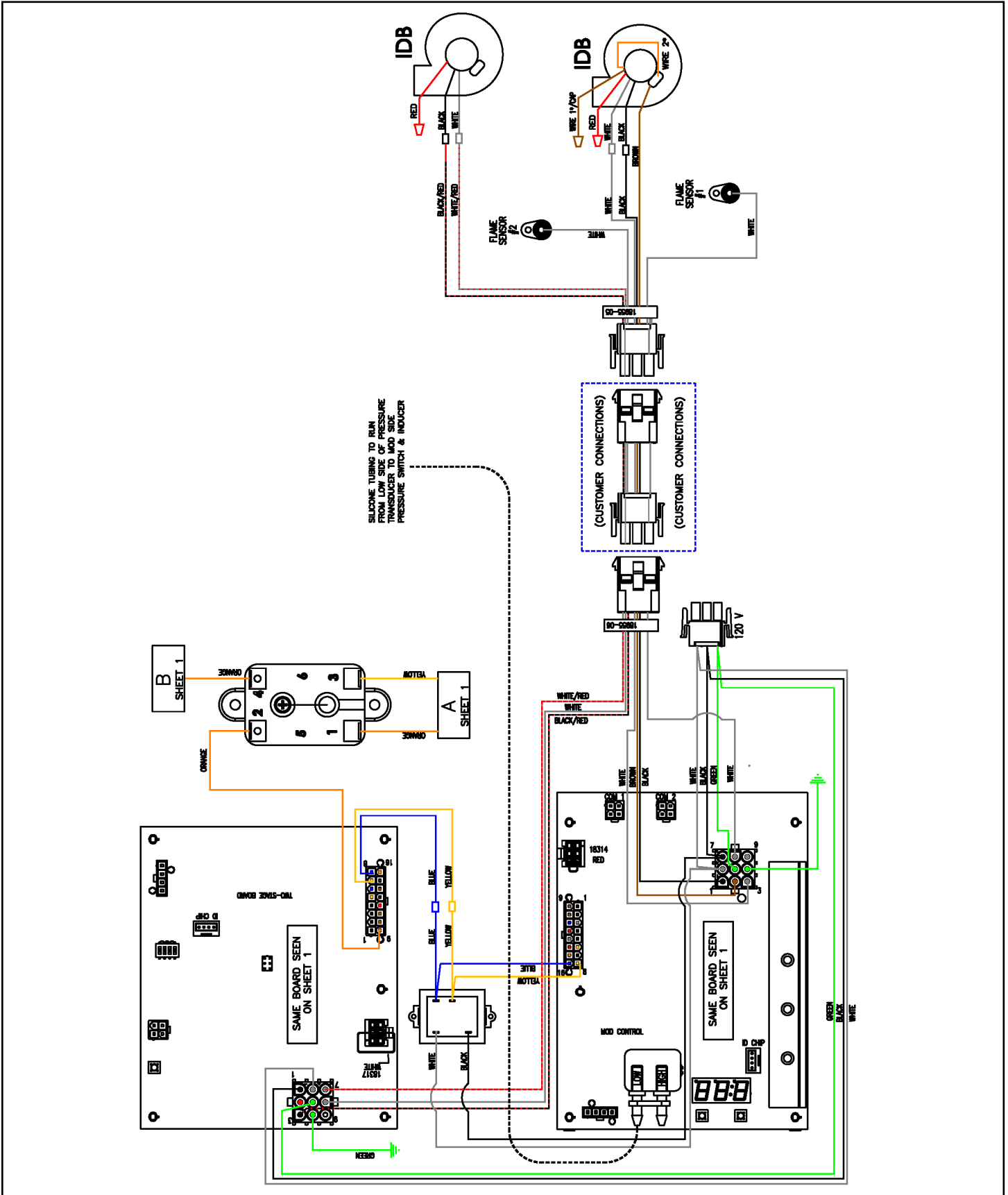


Figure 254: 1500 MBH (6:1, 10:1, 12:1, 20:1 Modulation) Staged Furnace

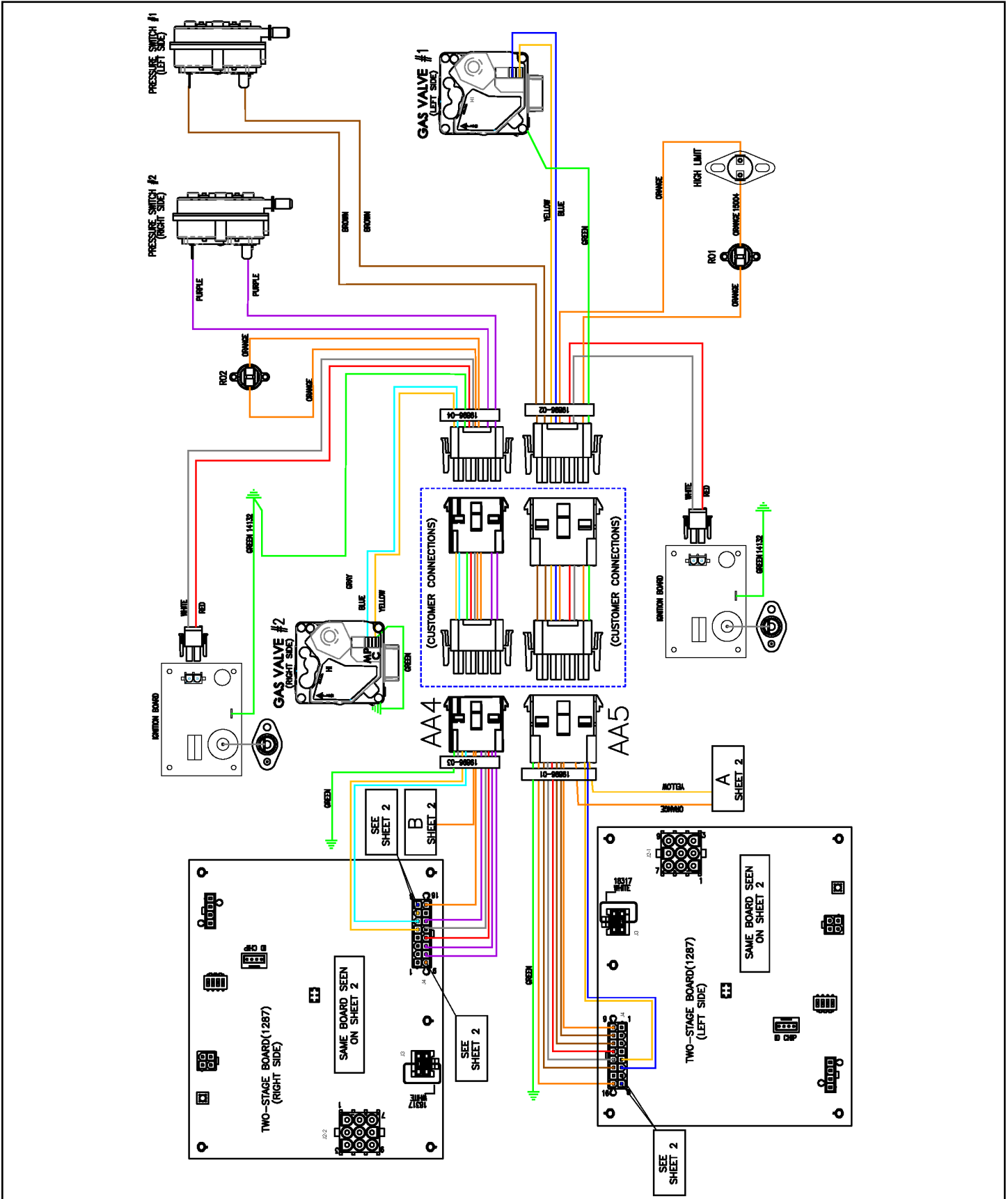
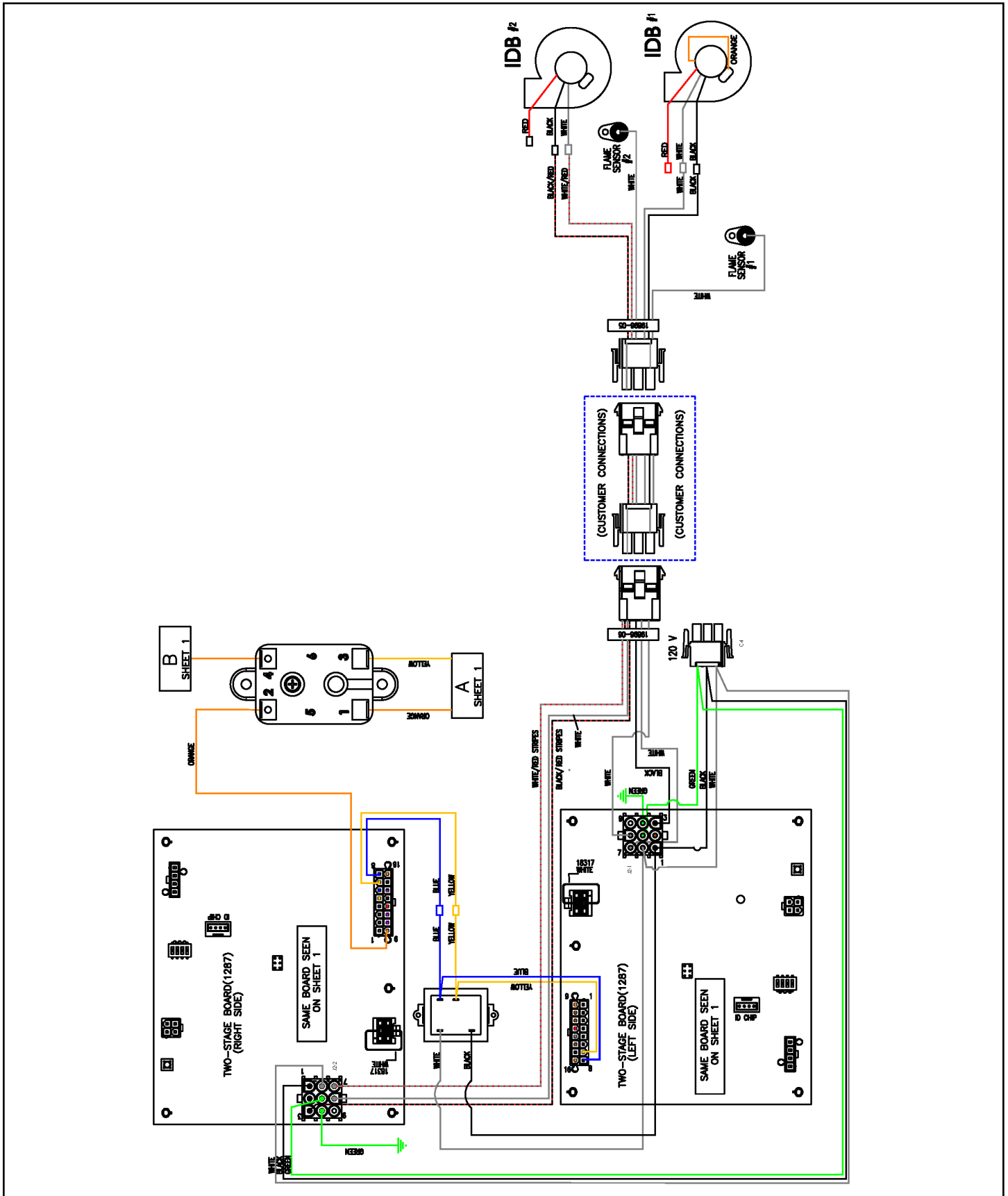


Figure 255: 1500 MBH (6:1, 10:1, 12:1, 20:1 Modulation) Staged Furnace (continued)



## Gas Furnace Ignition and Control Troubleshooting

### VB 1285 and VB 1287 Furnace Controllers

Daikin Applied's furnace controllers are electronic devices that deliver full control of the furnace. Control includes sequencing, ignition, safety, modulation (VB1285) or staging (VB1287) of the control valve, optional control of a second staged valve, and the induced draft motor. Inputs to the furnace control board are a MODBUS control. The furnace control will modulate (VB1285) or step (VB1287) the burner down to the furnace's minimum fire rate as shown in [Table 39 on page 143](#) and [Table 40 on page 145](#). Safety inputs include pressure line and electrical connection from the airflow proofing switch and electrical connection from the rollout switches. Control board outputs are to the igniter board, modulating gas valve (VB1285) or staged gas valve (VB1287), optional staged gas valve or staged control board, and to the induced draft motor.

### Furnace Diagnostics

The furnace control that operates the furnace has built-in, self-diagnostic capability. The control continuously monitors its own operation and the operation of the system. The LED on the control indicates the current system state, warnings, failures and test modes.

### VB 1285 Troubleshooting Guide

**Table 63: VB 1285 Furnace I.D. Plug Information (Displayed on Power-up)**

Display Information (example)	Description
C	Furnace series or model name, for example, C cabinet series.
CAB	
400	Furnace size in 1000's of BTU, for example, 400 kBTU.
NAT OR LP	Burner fuel type, for example, natural gas or LP.
GAS OR LP	
1.01	Software version, for example, v1.01

**Table 64: VB 1285 Normal Furnace Operation**

Display Information	Type	Description
888	Lockout (10s)	Board Failure (also during power-up).
OFF	Status	System Idle - Control board has power, no faults found, no call for heat.
PUR	Status	System is purging the heat exchanger – No gas on, no flame, inducer runs for the specified purge timings. Purge cycles occur immediately before and after each burner operation.
IGN	Status	System is initiating burner operation – Igniter energized, modulating valve moved to ignition setting, gas on. Maintained for the trial-for-ignition period and the five second flame stabilization period.
HEA	Status	Period between Ignition and Run – System checks completed before modulation control begins.
RUN	Status	Normal modulating operation.
RET	Status	System has had a failed ignition attempt or has lost flame during burner operation and is beginning another ignition cycle.

**Table 65: VB 1285 Troubleshooting**

Display Information	Diagnostic Code	Type	Description	Actions
888	1	Lockout	Board Failure (Also during power up)	Check wiring, replace control
OFF	2	Status	UP Mode: Burner state= Off	Normal - no action required
PUR	3	Status	UP Mode: Burner state = Purge	Normal - no action required
LEIN		Status	UP Mode: Burner state= Ignition	Normal - no action required
HEA		Status	UP Mode: Burner state= Warm-up	Normal - no action required
RUN		Status	UP Mode: Burner state= Run	Normal - no action required
RET	4/5	Status	UP Mode: Burner state= Retry	None - burner lost flame and is in retry
A01	4	Alert	Failed Ignition attempt	Check for spark, gas valve is on, voltage at gas valve, make sure gas is on.
A02	5	Alert	Lost Flame	Check and clean flame sensor, check gas supply, valve is on, voltage to valve.
A03	6	Alert	Insufficient Combustion Air-auto-derating	Check for flue blockage, hose blockage or leakage, proper inducer operation.
A04	7	Alert	Limited Low Fire (due to Lost Flame Auto Adaption)	Check and clean flame sensor or replace.
A05	8	Alert	Weak Flame Signal, Main burner	Check and clean flame sensor or replace.
A07	33	Alert	Air Modulating Failure (Inducer isn't modulating down)	Check for flue blockage, hose blockage or leakage, proper inducer operation.
A08	34	Alert	Air Sensor Null Pressure Check (out of tolerance)	Check pressure switch is closed during normal operation, check hoses for leaks.
A11	24	Alert	Failed Ignition, Split manifold burner, retries exhausted	Check gas valve is on, voltage to valve.
A15	10	Alert	Weak Flame Signal, one or more split-manifold staged burners	Check and clean flame sensor, make sure immersed in flame. Check manifold pressure.
E01	11	Lockout	Failed Ignition, retries have been exhausted	Check for spark, gas valve is on, voltage at gas valve, make sure gas is on.
E02	12	Lockout	Primary Limit Failure (or open fuse)	Check unit airflow, filters and blower motor operation, reset power to control.
E03	13	Lockout	Modulating Valve Failure	Check AC and DC voltage to valve
E04	14	Lockout	Air Pressure Sensor Reading Low (Pressure switch failed to open or insufficient air/blocked vent)	Check for flue blockage, hose blockage or leakage, proper inducer operation.
E05	15	Lockout	Air Pressure Sensor Reading High (Pressure switch failed to close)	Check for flue blockage, hose blockage or leakage, proper inducer operation.
E08	18	Lockout	Unexpected flame, Main burner	Check for short to ground on flame sensor, check wiring.
E09	19	Lockout	No R-W enable signal during CFH	Check wiring and component in circuit for proper operation.
E13	23	Lockout	Open fuse	Check for shorts in 24V circuit.
E18	22	Lockout	Unexpected flame, Split manifold burner	Check for short to ground on flame sensor, check wiring.
ED	20	Lockout	Invalid I.D. Plug Installed	Remove and check ID plug connections, reset power if problem persists replace ID plug.

## VB 1287 Troubleshooting Guide

### Display Code Identification

The VB 1287 controller utilizes a coded LED blinking strategy to communicate statuses, alerts, or failures (lockouts). The codes are represented using two LED lights on the control board. One light represents the numeric position of 0-9 (“ONES”) and one light represents the numeric position of 10, 20, 30, etc. (“TENS”), as shown in Figure 256. The color of the LEDs further indicates if the code is communicating a status (green), an alert (yellow), or a failure (red).

**NOTE:** For example, if the LED for the “ONES” position blinks yellow once and the LED for the “TENS” position blinks yellow three times, that represents “31” as a display code and indicates an alert.

Figure 256: VB 1287 Diagnostic Display Code Indicators

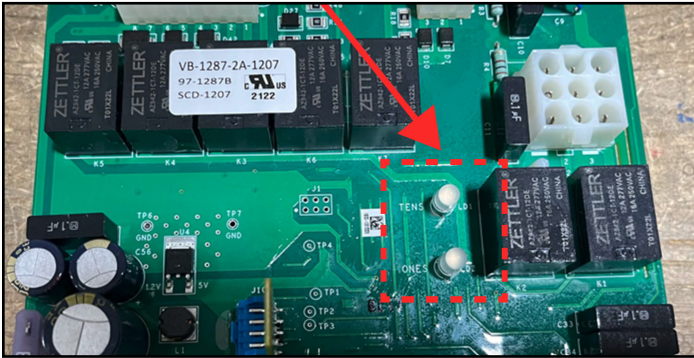


Table 66: VB 1287 Normal Furnace Operation

Display Code	LED Display Color	Type	Description
11	Green	Status	Control is idle. Control is in the OFF state.
12	Green	Status	Call for heat. Control is in the PURGE state.
13	Green	Status	Call for heat. Prime burner is in the RUN state.
33	Green	Status	Call for heat. Prime and split burners are in the RUN state.

Table 67: VB 1287 Alerts and Lockouts

Display Code	LED Display Color	Type	Description	Potential Action(s)
11 21 31	Yellow	Alert	Indicates that flame rod has low current.	N/A
13 23	Yellow	Alert	Call for heat prime burner is in RETRY.	
52	Yellow	Alert	Control is in idle mode. Keep alive timeout is expired.	
53	Yellow	Alert	Control is in idle mode. Manual override is in OFF position.	
54	Red	Lockout	ID plug failure.	Replace the ID chip.
55	Red	Lockout	Control board failure.	Replace the controller.
21 31	Red	Lockout	Flame detected without call for heat.	Check for voltage to the gas valve. Repair or replace the wiring if voltage is present. If voltage is not present, check for gas flow. If gas is flowing, verify supply and manifold pressures before replacing the valve.
43	Red	Lockout	Low pressure switch is open.	Potential failed draft inducer fan. Check pressure switch hose for leaks or blockage. Check for blockage in the inducer barb fitting. Check for condensate accumulation in the pressure switch and hose. Check the pressure switch wiring. Replace the pressure switch.

Display Code	LED Display Color	Type	Description	Potential Action(s)
44	Red	Lockout	High pressure switch is open.	<p>Potential failed draft inducer fan.</p> <p>Check pressure switch hose for leaks or blockage.</p> <p>Check for blockage in the inducer barb fitting.</p> <p>Check for condensate accumulation in the pressure switch and hose.</p> <p>Check the pressure switch wiring.</p> <p>Replace the pressure switch.</p>
41 42	Red	Lockout	Pressure switch closed while inducer is off.	<p>Check pressure switch wiring.</p> <p>Check draft inducer wiring.</p> <p>Check pressure switch for closed contact using Ohmmeter.</p> <p>Replace the pressure switch.</p>
12 22	Red	Lockout	Exceeded number of ignition trials.	<p>Check gas supply pressure to the unit.</p> <p>Check manifold pressure.</p> <p>Check the gas valve is switch is in the on position.</p> <p>Check to make sure spark is present if igniter is damaged replace it.</p> <p>Check flame sensor for damage or corrosion. If damaged, replace it.</p> <p>Check flame sensor wiring.</p> <p>Check for air leaks.</p> <p>Check for re-circulation of flue products.</p>
13 23 33	Red	Lockout	Too many flame losses.	<p>Check the flame sensor for damage or corrosion. If damaged, replace it.</p> <p>Check the flame sensor wire is connected correctly.</p> <p>Check for flue product recirculation.</p> <p>Check flame stability.</p>
51	Red	Lockout	High limit or rollout switch open.	<p>Check for open switches with Ohmmeter.</p> <p>If limit switch is open, check unit temp rise and airflow.</p> <p>If rollout is open, check for flue vent blockage or air leaks in the cabinet.</p> <p>Reset the rollout switch and observe the flame for signs of rollout.</p>
52	Red	Lockout	Safety checks at start-up failed.	<p>Check rollout.</p> <p>Check limit.</p> <p>Check APS.</p>
15 25 35	Red	Lockout	Gas valve is in the incorrect state.	<p>Check gas valve wiring.</p> <p>Check for shorts in 24V circuits.</p> <p>Replace controller.</p>
14 24 34	Red	Lockout	Gas valve is shorted to 24V.	<p>Check wiring.</p> <p>Change gas valve.</p>
<b>Steady On</b>	Red	Lockout	Controller failure.	<p>Replace control board.</p>
<b>Rapid Blinking</b>	Red	Lockout	ID chip failure.	<p>Remove power from the board and replace ID chip.</p>

# Maxitrol EXA Star Valve Calibration

## Over-Traveled State Calibration

### WARNING

Adjusting the modulating valve beyond its physical limits may result in permanent damage to the valve and production of carbon monoxide (CO) during modulation. Serious injury and death can result if not adjusted correctly. All adjustments should be made by a qualified service agency in accordance with the manufacturer's instructions and all applicable codes and requirements of the authority having jurisdiction. If the information in these instructions is not followed exactly, a fire, an explosion, or the production of carbon monoxide may result, causing property damage, personal injury, or death. The qualified service agency performing this work assumes the responsibility for the proper adjustment of the appliance.

Follow the procedure detailed here if there has been an inadvertent adjustment to the Maxitrol EXA Star valve, resulting in a mechanically over-traveled state.

Indications of a mechanically over-traveled gas valve include:

- Acceptable combustion measurements while heating section is in modulating state are not achievable. An example of this would be elevated levels of carbon monoxide (CO).
- Modulating gas valve does not retain high/low fire settings upon unit power cycle.

### Tools Required

- Electrical Multimeter
- Manometer

### Before Proceeding with Calibration

Refer to the heating section manifold for the low and high fire setpoint W.C. pressure.

### Calibration Procedure

1. Cycle power to the unit.
2. When power has returned, use the MicroTech unit controller's "Manual Control" menu to set the heating output to 100%.

**NOTE:** Ensure all required dampers are opened and adequate airflow is provided across the heating section prior to setting the output to 100%.

3. Verify inlet pressure to the modulating valve is 4.75-5.00 in. W.C.
4. Press and hold button #2 to enter low fire setting mode. Refer to "Valve Setting" on page 192.
5. Adjust gas flow slowly by pressing and releasing button #2 repeatedly until the desired low fire manifold pressure is reached.
  - Refer to the heating section manifold for the low fire set point W.C. manifold pressure.
  - Do not press and hold the button as the step rate will increase rapidly and may result in an over-traveled state.

6. Press and hold both button #1 and button #2 simultaneously to save the low fire setting.
7. Press and hold button #1 to enter high fire setting mode. Refer to "Valve Setting" on page 192.
8. Adjust manifold pressure by slowly pressing and releasing button #2 repeatedly to set the valve to 1.5-2.0 in. W.C.
  - Do not press and hold the button as the step rate will increase rapidly and may result in an over-traveled state.
9. Press and hold both button #1 and button #2 simultaneously to save the high fire setting.
10. Cycle power to the unit.
11. When power has returned, use the MicroTech unit controller's "Manual Control" menu to set the heating output to 100%. If the manifold pressures do not come back to where they were set before the power cycle, repeat Steps 4 through 8.

**NOTE:** It may take more than one cycle to bring the valve into normal operating range.

12. If manifold pressures return to the values that were set before the power cycle, continue with Step 13.
13. Press and hold button #1 to enter high fire setting mode. Refer to "Valve Setting" on page 192.
14. Verify inlet pressure to the modulator valve is 4.75-5.00 in. W.C.
15. Increase manifold pressure by pressing and releasing button #1 repeatedly.
  - Do not press and hold the button as the step rate will increase rapidly and may result in an over-traveled state.
16. Target manifold pressure is 3.2-3.5 in. W.C. while the valve is in high setting mode.
  - Refer to the heating section manifold for the high fire set point W.C. manifold pressure.
17. Press and hold both button #1 and button #2 to save the high fire setting.
  - If the modulating valve is receiving <10 VDC with a maximum demand to the furnace control, there may be a small shift in manifold pressure after the high fire setting is saved.
  - Typically, this will result in 3.2-3.4 in. W.C. manifold pressure.
18. Cycle power to the unit.
19. When power has returned, use the MicroTech unit controller's "Manual Control" menu to set the heating output to 100%.
20. Observe manifold pressure. If the voltage to the modulating valve is <10VDC at 100% demand to the furnace control, the pressure should be lower than the pressure in Step 16 (at same inlet pressure).
21. Send a call for heat at minimum demand.
22. If manifold pressures at minimum have changed from the previous setting, repeat Steps 4 and 5 to reset.

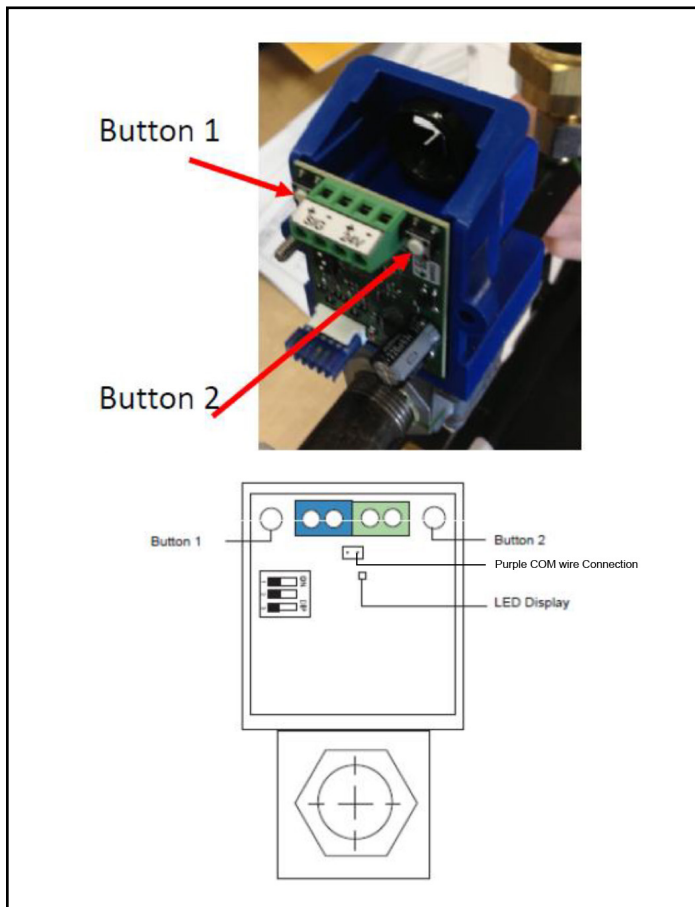
23. Cycle power to unit and verify settings have been properly saved by sending a call for heat at maximum and minimum demand.

### Valve Setting

The Maxitrol EXA Star modulating gas valve series has two (2) buttons and a communication LED for user interface. The buttons are used to set the valve for high and low fire settings as shown in Figure 257.

1. High fire setting - LED will be SOLID red
2. Low fire setting - LED will be BLINKING red
3. Operating Mode - LED will be OFF

**Figure 257: Maxitrol EXA Star LEDs**



# Warranty

## Rooftop Equipment Warranty Registration Form

### In-Warranty Return Material Procedure

Material other than compressors may not be returned except by permission of authorized factory service personnel of Daikin Applied at Minneapolis, Minnesota.

A "return goods" tag will be sent to be included with the returned material. Enter the information as called for on the tag in order to expedite handling at our factories and issuance of credits. All parts shall be returned to the factory designated on the return goods tag, transportation charges prepaid.

The return of the part does not constitute an order for replacement. A purchase order for the replacement part must be entered through your nearest Daikin Applied representative. The order should include the component's part number and description and the model and serial numbers of the unit involved.

# Daikin Applied Limited Warranty



**DAIKIN APPLIED AMERICAS INC.  
LIMITED PRODUCT WARRANTY  
(United States and Canada)**

## **WARRANTY**

Daikin Applied Americas Inc. dba Daikin Applied ("Company") warrants to contractor, purchaser and any owner of the product (collectively "Owner") that, subject to the exclusions set forth below Company, at its option, will repair or replace defective parts in the event any product manufactured by Company, including products sold under the brand name Daikin and used in the United States or Canada, proves defective in material or workmanship within twelve (12) months from initial startup or eighteen (18) months from the date shipped by Company, whichever occurs first. Authorized replacement parts are warranted for the remainder of the original warranty. All shipments of such parts will be made FOB factory, freight prepaid and allowed. Company reserves the right to select carrier and method of shipment. In addition, Company provides labor to repair or replace warranty parts during Company normal working hours on products with rotary screw compressors or centrifugal compressors. Warranty labor is not provided for any other products.

Company must receive the Registration and Startup Forms for products containing motor compressors and/or furnaces within ten (10) days of original product startup, or the ship date and the startup date will be deemed the same for determining the commencement of the warranty period and this warranty shall expire twelve (12) months from that date. For additional consideration, Company will provide an extended warranty(ies) on certain products or components thereof. The terms of the extended warranty(ies) are shown on a separate extended warranty statement.

No person (including any agent, sales representative, dealer or distributor) has the authority to expand the Company's obligation beyond the terms of this express warranty or to state that the performance of the product is other than that published by Company.

## **EXCLUSIONS**

1. If free warranty labor is available as set forth above, such free labor does not include diagnostic visits, inspections, travel time and related expenses, or unusual access time or costs required by product location.
2. Refrigerants, fluids, oils and expendable items such as filters are not covered by this warranty.
3. This warranty shall not apply to products or parts : (a) that have been opened, disassembled, repaired, or altered, in each case by anyone other than Company or its authorized service representative; (b) that have been subjected to misuse, abuse, negligence, accidents, damage, or abnormal use or service; (c) that have not been properly maintained; (d) that have been operated or installed, or have had startup performed, in each case in a manner contrary to Company's printed instructions; (e) that have been exposed, directly or indirectly, to a corrosive atmosphere or material such as, but not limited to, chlorine, fluorine, fertilizers, waste water, urine, rust, salt, sulfur, ozone, or other chemicals, contaminants, minerals, or corrosive agents; (f) that were manufactured or furnished by others and/or are not an integral part of a product manufactured by Company; or (g) for which Company has not been paid in full.
4. This warranty shall not apply to products with rotary screw compressors or centrifugal compressors if such products have not been started, or if such startup has not been performed, by a Daikin Applied or Company authorized service representative.

## **SOLE REMEDY AND LIMITATION OF LIABILITY**

THIS WARRANTY CONSTITUTES THE SOLE WARRANTY MADE BY COMPANY. COMPANY'S LIABILITY TO OWNER AND OWNER'S SOLE REMEDY UNDER THIS WARRANTY SHALL NOT EXCEED THE LESSER OF: (i) THE COST OF REPAIRING OR REPLACING DEFECTIVE PRODUCTS; AND (ii) THE ORIGINAL PURCHASE PRICE ACTUALLY PAID FOR THE PRODUCTS. COMPANY MAKES NO REPRESENTATION OR WARRANTY, EXPRESS OR IMPLIED, REGARDING PREVENTION OF MOLD/MOULD, FUNGUS, BACTERIA, MICROBIAL GROWTH, OR ANY OTHER CONTAMINATES. THIS WARRANTY IS GIVEN IN LIEU OF ALL OTHER WARRANTIES, INCLUDING, WITHOUT LIMITATION, THE IMPLIED WARRANTIES OF MERCHANTABILITY, FITNESS FOR A PARTICULAR PURPOSE, AND NON-INFRINGEMENT, WHICH ARE HEREBY DISCLAIMED. IN NO EVENT AND UNDER NO CIRCUMSTANCE SHALL COMPANY BE LIABLE TO OWNER OR ANY THIRD PARTY FOR INCIDENTAL, INDIRECT, SPECIAL, CONTINGENT, CONSEQUENTIAL, DELAY OR LIQUIDATED DAMAGES FOR ANY REASON, ARISING FROM ANY CAUSE WHATSOEVER, WHETHER THE THEORY FOR RECOVERY IS BASED IN LAW OR IN EQUITY, OR IS UNDER A THEORY OF BREACH CONTRACT OR WARRANTY, NEGLIGENCE, STRICT LIABILITY, OR OTHERWISE. THE TERM "CONSEQUENTIAL DAMAGE" INCLUDES, WITHOUT LIMITATION, THOSE DAMAGES ARISING FROM BUSINESS INTERRUPTION OR ECONOMIC LOSS, SUCH AS LOSS OF ANTICIPATED PROFITS, REVENUE, PRODUCTION, USE, REPUTATION, DATA OR CROPS.

## **ASSISTANCE**

To obtain assistance or information regarding this warranty, please contact your local sales representative or a Daikin Applied office.

Form No. 933-430285Y-01-A (11/2023)  
Part No. 043028500 Rev.0F

# Warranty Registration Form



## Rebel Applied Equipment Warranty Registration Form

To comply with the terms of Daikin Applied Warranty, register start date and upload this form within 10 days to the Warranty Department of Daikin Applied.

Check, test, and start procedure for Rebel Applied.

### GENERAL INFORMATION

Job Name: \_\_\_\_\_ Unit No.: \_\_\_\_\_

SOI No.: \_\_\_\_\_

Installation address: \_\_\_\_\_

City: \_\_\_\_\_ State: \_\_\_\_\_

Purchasing contractor: \_\_\_\_\_

City: \_\_\_\_\_ State: \_\_\_\_\_

Name of person doing start-up: \_\_\_\_\_

Company name: \_\_\_\_\_

Address: \_\_\_\_\_

City/State/Zip: \_\_\_\_\_

### UNIT INFORMATION

Unit model number: \_\_\_\_\_

Unit serial number: \_\_\_\_\_

Compressor 1 model number: \_\_\_\_\_ Serial number: \_\_\_\_\_

Compressor 3 model number: \_\_\_\_\_ Serial number: \_\_\_\_\_

Compressor 5 model number: \_\_\_\_\_ Serial number: \_\_\_\_\_

Compressor 2 model number: \_\_\_\_\_ Serial number: \_\_\_\_\_

Compressor 4 model number: \_\_\_\_\_ Serial number: \_\_\_\_\_

Compressor 6 model number: \_\_\_\_\_ Serial number: \_\_\_\_\_

Fan Motor 1-4 model number: \_\_\_\_\_ Serial number: \_\_\_\_\_

Serial number: \_\_\_\_\_

Serial number: \_\_\_\_\_

Serial number: \_\_\_\_\_

Serial number: \_\_\_\_\_

Fan Motor 6-10 model number: \_\_\_\_\_ Serial number: \_\_\_\_\_

Serial number: \_\_\_\_\_

Serial number: \_\_\_\_\_

Serial number: \_\_\_\_\_



Rebel Applied Equipment Warranty Registration Form

Select Yes or No. If not applicable to the type of unit, select N/A.

I. INITIAL CHECK

- A. Is any shipping damage visible?  Yes  No  N/A
- B. Has the discharge static and or building pressure reference been properly located in the building?  Yes  No  N/A
- C. Do fans turn freely?  Yes  No  N/A
- D. Electrical service corresponds to unit nameplate?  Yes  No  N/A
  - D1. Voltage at Terminal Block each phase to ground | Disconnect      1-G \_\_\_\_\_ V 2-G \_\_\_\_\_ V 3-G \_\_\_\_\_ V
  - D2. Voltage at Terminal Block | Disconnect                                      1-2 \_\_\_\_\_ V 2-3 \_\_\_\_\_ V 1-3 \_\_\_\_\_ V
- E. Unit phased correctly?  Yes  No  N/A
- F. Is the main disconnect adequately fused and are fuses installed?  Yes  No  N/A
- G. Are crankcase heaters operating, and have they been operating 24 hours prior to start-up?  Yes  No  N/A
- H. Are all electrical power connections tight?  Yes  No  N/A
- I. Is the condensate drain trapped?  Yes  No  N/A
- J. Is the supply air temperature sensor installed per the installation manual?  Yes  No  N/A

II. FAN DATA

- A. Check rotation of supply fans?  Yes  No  N/A
- B. Voltage at supply fan motor or VFD: ..... 1-2 \_\_\_\_\_ V 2-3 \_\_\_\_\_ V 1-3 \_\_\_\_\_ V
- C. Supply fan motor amp draw(s) per phase: ..... SF-1 L1 \_\_\_\_\_ L2 \_\_\_\_\_ L3 \_\_\_\_\_  
 \*Fan array units only ..... SF-2 L1 \_\_\_\_\_ L2 \_\_\_\_\_ L3 \_\_\_\_\_  
 \*If a VFD fan measure amps draw on line side of VFD SF-3 L1 \_\_\_\_\_ L2 \_\_\_\_\_ L3 \_\_\_\_\_  
 SF-4 L1 \_\_\_\_\_ L2 \_\_\_\_\_ L3 \_\_\_\_\_  
 SF-5 L1 \_\_\_\_\_ L2 \_\_\_\_\_ L3 \_\_\_\_\_  
 SF-6 L1 \_\_\_\_\_ L2 \_\_\_\_\_ L3 \_\_\_\_\_
- D. What is the supply fan rpm? .....
- E. Check rotation of Return/Exhaust fans?  Yes  No  N/A
- F. Voltage at Return - Exhaust fan motor or VFD: ..... 1-2 \_\_\_\_\_ V 2-3 \_\_\_\_\_ V 1-3 \_\_\_\_\_ V
- G. Return - Exhaust fan motor amp draw(s) per phase: ..... R/E F-1 L1 \_\_\_\_\_ L2 \_\_\_\_\_ L3 \_\_\_\_\_  
 \*Fan array units only ..... R/E F-2 L1 \_\_\_\_\_ L2 \_\_\_\_\_ L3 \_\_\_\_\_  
 \*If a VFD fan measure amps draw on line side of VFD R/E F-3 L1 \_\_\_\_\_ L2 \_\_\_\_\_ L3 \_\_\_\_\_  
 R/E F-4 L1 \_\_\_\_\_ L2 \_\_\_\_\_ L3 \_\_\_\_\_  
 R/E F-5 L1 \_\_\_\_\_ L2 \_\_\_\_\_ L3 \_\_\_\_\_  
 R/E F-6 L1 \_\_\_\_\_ L2 \_\_\_\_\_ L3 \_\_\_\_\_
- H. What is the Return - Exhaust fan rpm? .....
- I. Record supply static pressure at unit in inches of H<sub>2</sub>O: .....
- J. Record return static pressure at unit (with outside air dampers closed) in inches of H<sub>2</sub>O: .....
- K. Check service menus Modbus com statuses are all OK?  Yes  No  N/A



Rebel Applied Equipment Warranty Registration Form

Select Yes or No. If not applicable to the type of unit, select N/A.

III. START-UP COMPRESSOR OPERATION

- A. Do compressors have holding charge?
B. Are compressor shipping brackets removed?
C. Are compressors rotating in the right direction?
D. Do condenser fans rotate in the right direction?
E. Ambient temperature (°F):

IV. PERFORMANCE DATA

- A. Compressor voltage across each phase: 1-2 V 2-3 V 1-3 V
B. Compressor amperage of fully loaded compressor: Compressor #1 - Phase 1 Phase 2 Phase 3
Compressor #2 - Phase 1 Phase 2 Phase 3
Compressor #3 - Phase 1 Phase 2 Phase 3
Compressor #4 - Phase 1 Phase 2 Phase 3
Compressor #5 - Phase 1 Phase 2 Phase 3
Compressor #6 - Phase 1 Phase 2 Phase 3
C. Discharge pressure, one compressor: Circuit 1 psig Circuit 2 psig
D. Suction pressure, one compressor: Circuit 1 psig Circuit 2 psig
E. EVI percentage, one compressor: N/A Circuit 1 % Circuit 2 %
F. Discharge pressure, fully loaded, 2-3 compressors: Circuit 1 psig Circuit 2 psig
G. Suction pressure, fully loaded, 2-3 compressors: Circuit 1 psig Circuit 2 psig
H. Liquid press, fully loaded, 2-3 compressors (at liquid line shutoff valve): Circuit 1 psig Circuit 2 psig
I. Liquid temperature, fully loaded, 2-3 compressors: Circuit 1 psig Circuit 2 psig
J. EVI percentage, fully loaded, 2-3 compressors: N/A Circuit 1 % Circuit 2 %
K. Suction line temperature: Circuit 1 °F Circuit 2 °F
L. Superheat: Circuit 1 °F Circuit 2 °F
M. Subcooling: Circuit 1 °F Circuit 2 °F
N. Discharge superheat: Circuit 1 °F Circuit 2 °F
O. Did unit control DAT to DAT setpoint?
P. Is the liquid line in the line sightglass clean and dry?
Q. Record discharge air temperature at discharge of unit: °F



Rebel Applied Equipment Warranty Registration Form

Select Yes or No. If not applicable to the type of unit, select N/A.

- R. Verify Reheat Valve Operation?  Yes  No  N/A
- S. Reheat Valve outlet temperaute with Dehum OFF . . . . . Circuit 1 \_\_\_\_\_°F      Circuit 2 \_\_\_\_\_°F
- T. Reheat Valve outlet temperaute with Dehum ON . . . . . Circuit 1 \_\_\_\_\_°F      Circuit 2 \_\_\_\_\_°F
- U. Are all valve caps and packing tight after start-up? . . . . .  Yes  No  N/A

IV. Hot Water Coil

- A. Pressure test OK? . . . . .  Yes  No  N/A

V. Chilled Water coil

- A. Pressure test OK? . . . . .  Yes  No  N/A

VI. Heat Recovery

- A. Heat wheel rotates freely? . . . . .  Yes  No  N/A
- B. Heat wheel VFD operates properly? . . . . .  Yes  No  N/A
- C. Heat wheel . . . . . Model No. \_\_\_\_\_ Serial No. \_\_\_\_\_
- D. Check for air bypass around heat wheel. . . . .  Yes  No  N/A

VII. ELECTRIC HEAT

- A. Electrical heat service corresponds to unit nameplate? . . . . .  Yes  No  N/A
- B. Electric Furnace . . . . . Model no \_\_\_\_\_ Serial no. \_\_\_\_\_  
Volts \_\_\_\_\_ Hertz \_\_\_\_\_ Phase \_\_\_\_\_
- C. Are there any signs of physical damage to the electric heat coils? . . . . .  Yes  No  N/A
- D. Have all electrical terminals been tightened? . . . . .  Yes  No  N/A
- E. Does sequence controller stage contactors properly? . . . . .  Yes  No  N/A
- F. Electric heater voltage across each phase: . . . . . L1 \_\_\_\_\_ L2 \_\_\_\_\_ L3 \_\_\_\_\_
- G. Amp draw across each phase at each heating stage:  

	Stage 1	Stage 2	Stage 3	Stage 4	Stage 5	Stage 6
Phase L1:	_____	_____	_____	_____	_____	_____
Phase L2:	_____	_____	_____	_____	_____	_____
Phase L3:	_____	_____	_____	_____	_____	_____
- H. FLA: L1 \_\_\_\_\_ L2 \_\_\_\_\_ L3 \_\_\_\_\_
- I. Heat section turns off upon loss of airflow?.. . . . .  Yes  No  N/A



Rebel Applied Equipment Warranty Registration Form

Select Yes or No. If not applicable to the type of unit, select N/A.

VIII. FURNACE CHECK, TEST, & START

A. Gas Furnace .....Model no \_\_\_\_\_ Serial no. \_\_\_\_\_

B. Gas pressure at main (inches w.c.): .....

C. Gas pressure at manifold (inches w.c.): .....

D. Flame failure shutoff (seconds): .....

E. Heat section turns off upon loss of airflow? . . . . . Yes  No  N/A

F. Main Gas Valves shut off Operational? . . . . . Yes  No  N/A

G. Gas Heat Performance

Mod gas pressure

Min fire rate (20-1 & 100-1 is 5%, 10-1 is 10%, 5-1 is 20%) ..... Manifold pressure \_\_\_ in w.c CO \_\_\_ ppm CO2 \_\_\_ ppm
At 50% ..... Manifold pressure \_\_\_ in w.c CO \_\_\_ ppm CO2 \_\_\_ ppm
At 100% ..... Manifold pressure \_\_\_ in w.c CO \_\_\_ ppm CO2 \_\_\_ ppm
Gas Supply at 100% \_\_\_\_\_ In Wc

Staged gas manifold pressures

1st stage ..... In wc CO \_\_\_ ppm CO2 \_\_\_ ppm Gas Supply pressure \_\_\_\_\_ In Wc
2nd stage ..... In wc CO \_\_\_ ppm CO2 \_\_\_ ppm Gas Supply pressure \_\_\_\_\_ In Wc
3rd stage ..... In wc CO \_\_\_ ppm CO2 \_\_\_ ppm Gas Supply pressure \_\_\_\_\_ In Wc
4th stage ..... In wc CO \_\_\_ ppm CO2 \_\_\_ ppm Gas Supply pressure \_\_\_\_\_ In Wc

IX. MAINTAINING MICROTECH CONTROL PARAMETER RECORDS

After the unit is checked, tested, and started and the final control parameters are set, Save the final settings by exporting the param.bin and ucf files. Keep these records on file and update them whenever changes to the control parameters are made. Keeping a record facilitates any required analysis and troubleshooting of the system operation and facilitates restoration after a controller replacement.

Thank you for completing this form. Please sign and date below.

Signature \_\_\_\_\_ Startup date: \_\_\_\_\_

Register equipment start date and upload form on the Daikin Applied FieldCare Portal at https://fieldcare.daikinapplied.com

Please fill out the Daikin Applied "Quality Assurance Survey Report" and list any additional comments that could affect the operation of this unit; e.g., shipping damage, failed components, adverse installation applications, etc. If additional comment space is needed, write the comment(s) on a separate sheet, attach it to the Survey Report and return it to the Warranty Department of Daikin Applied with the completed Equipment Warranty Registration form.

Clear Form



### Quality Assurance Survey Report

To whom it may concern:

Please review the items below upon receiving and installing our product. Select N/A on any item that does not apply to the product.

Job Name: \_\_\_\_\_ Daikin Applied S.O. No. \_\_\_\_\_

Installation address: \_\_\_\_\_

City: \_\_\_\_\_ State: \_\_\_\_\_

Purchasing contractor: \_\_\_\_\_

City: \_\_\_\_\_ State: \_\_\_\_\_

Name of person doing start-up (print): \_\_\_\_\_

Company name: \_\_\_\_\_

Address: \_\_\_\_\_

City/State/Zip: \_\_\_\_\_

Unit model number: \_\_\_\_\_ Unit serial number: \_\_\_\_\_

1. Is there any shipping damage visible? ..... Yes  No  N/A

Location on unit \_\_\_\_\_

2. How would you rate the overall appearance of the product; i.e., paint, fin damage, etc.? Excellent  Good  Fair  Poor

3. Did all sections of the unit fit together properly? ..... Yes  No  N/A

4. Did the cabinet have any air leakage? ..... Yes  No  N/A

Location on unit \_\_\_\_\_

5. Were there any refrigerant leaks? ..... Yes  No  N/A

From where did it occur? ..... Shipping  Workmanship  Design

6. Does the refrigerant piping have excessive vibration? ..... Yes  No  N/A

Location on unit \_\_\_\_\_

7. Did all of the electrical controls function at start-up? ..... Yes  No  N/A

Comments \_\_\_\_\_

8. Did the labeling and schematics provide adequate information? ..... Yes  No  N/A

9. How would you rate the serviceability of the product? Excellent  Good  Fair  Poor

10. How would you rate the overall quality of the product? Excellent  Good  Fair  Poor

11. How does the quality of Daikin Applied products rank in relation to competitive products? Excellent  Good  Fair  Poor

Comments \_\_\_\_\_

Please list any additional comments which could affect the operation of this unit; i.e., shipping damage, failed components, adverse installation applications, etc. If additional comment space is needed, write the comment(s) on a separate sheet, attach the sheet to this completed Quality Assurance Survey Report, and return it to the Warranty Department with the completed preceding "Equipment Warranty Registration Form".



# COMPLETE HVAC SYSTEM SOLUTIONS

SELF-CONTAINED | ROOFTOPS | COILS | CONDENSING UNITS  
AIR HANDLERS | WATER-COOLED CHILLERS | AIR-COOLED CHILLERS  
MODULAR CENTRAL PLANTS | CONNECTED BUILDING CONTROLS  
UNIT HEATERS | FAN COILS | AIR PURIFIERS | WATER SOURCE HEAT PUMPS  
VARIABLE AIR VOLUME UNITS | UNIT VENTILATORS



13600 INDUSTRIAL PARK BLVD. | MINNEAPOLIS, MN 55441  
1-800-432-1342 | 763-553-5330

LEARN MORE AT  
**DAIKINAPPLIED.COM**

PART NUMBER: IM1384

© 2026 DAIKIN APPLIED | (800) 432.1342 | WWW.DAIKINAPPLIED.COM