



INSTALLATION & MAINTENANCE

IM 777-24

MARCH 2026

# SKYLINE® OUTDOOR AIR HANDLER



- HEATING AND COOLING
- R410A, R32, OR R454B REFRIGERANT
- MODELS: OAC OR OAH
- SIZES 003 THROUGH 102

# Table of Contents

<b>Introduction</b> . . . . .	<b>3</b>	<b>Operation Guidelines</b> . . . . .	<b>39</b>
Compliance Statements . . . . .	4	Startup Checks . . . . .	39
Unit Labels . . . . .	5	Before Starting the Unit . . . . .	39
Receiving and Handling . . . . .	5	VFD Setup . . . . .	40
Gas Furnace . . . . .	6	Fan Startup . . . . .	40
<b>Mechanical Installation</b> . . . . .	<b>7</b>	Fan Wheel Alignment . . . . .	40
Lifting Guidance . . . . .	7	Setscrews . . . . .	42
Transit and Temporary Storage . . . . .	8	<b>Daikin Applied Fan Array</b> . . . . .	<b>43</b>
Curb Mounting and Unit Leveling . . . . .	9	<b>Daikin Applied ECM Fan Array</b> . . . . .	<b>46</b>
Assembling Sections . . . . .	10	<b>Fan Operating Limits</b> . . . . .	<b>53</b>
Shipping Sections . . . . .	10	Fan Vibration Levels . . . . .	54
Panels, Frame Channels, and Doors . . . . .	12	<b>Gas Phase Filtration Technology</b> . . . . .	<b>55</b>
Field Mounting Junction Boxes /		Supplemental Hood Installation . . . . .	55
Other Components . . . . .	14	Supplemental Roof and Base Installation . . . . .	56
HEPA Holding Frame, Filter, and		<b>Service and Maintenance</b> . . . . .	<b>58</b>
Prefilter Installation . . . . .	14	Periodic Maintenance . . . . .	58
Duct Connections . . . . .	18	Fan Drive . . . . .	59
Dampers and Hoods . . . . .	19	Fan Drive Belt Adjustment . . . . .	62
Collapsible Hood Assembly . . . . .	20	Front Load Filter Option . . . . .	63
Mounting Actuators . . . . .	20	Filter Gauges . . . . .	63
Angled Economizer Actuator Access . . . . .	20	Coils . . . . .	64
Isolation Dampers for Multiple Fans . . . . .	20	Winterizing Water Coils . . . . .	64
Piping Vestibules . . . . .	21	Removing and Replacing Components . . . . .	64
Piping and Coils . . . . .	23	<b>A2L Refrigerant Guidelines (If Applicable)</b> . . . . .	<b>67</b>
Integral Face and Bypass Coils . . . . .	28	Minimum Room Area . . . . .	68
Internal Isolation Assembly Adjustment . . . . .	32	<b>Parts, Service, and Warranty Procedure</b> . . . . .	<b>79</b>
HCAI Seismic Anchoring/Mounting . . . . .	34	Replacement Parts . . . . .	79
<b>Electrical Installation</b> . . . . .	<b>35</b>	Warranty Return Material Procedure . . . . .	79
<b>Electric and Gas Heat</b> . . . . .	<b>37</b>	<b>Limited Warranty</b> . . . . .	<b>80</b>
Electric Heat . . . . .	37	<b>Warranty Registration Form</b> . . . . .	<b>81</b>
		<b>Quality Assurance Survey</b> . . . . .	<b>87</b>

©2026 Daikin Applied, Minneapolis, MN. All rights reserved throughout the world. This document contains the most current product information as of this printing. Daikin Applied Americas Inc. has the right to change the information, design, and construction of the product represented within the document without prior notice. For the most up-to-date product information, please go to [www.DaikinApplied.com](http://www.DaikinApplied.com).

™@ Skyline, MicroTech, and Daikin Applied are trademarks or registered trademarks of Daikin Applied Americas Inc. The following are trademarks or registered trademarks of their respective companies: BACnet from American Society of Heating, Refrigerating and Air-Conditioning Engineers, Inc.; Echelon, LonWorks, LonMark, and LonTalk from Echelon Corporation; Modbus from Schneider Electric; and Windows from Microsoft Corporation.

# Introduction

## General Information

**⚠ WARNING**

Sharp edges and coil surfaces are a potential injury hazard. Avoid contact.

Skyline® indoor air handlers are designed to be weather resistant and can be installed outdoors. The system design and installation must follow accepted industry practice as described in the ASHRAE Handbook, the National Electric Code, and other applicable standards. Install this equipment in accordance with regulations of authorities having jurisdiction and all applicable codes.

Installation and maintenance are to be performed only by licensed, if required by local codes and regulations, or qualified personnel, who are familiar with local codes and regulations and are experienced with this type of equipment. Sheet metal parts, self-tapping screws, fins, clips, and such items inherently have sharp edges; the installer should exercise caution.

This unit follows UL standards and should only be connected with units that follow the same international standard.

## Nomenclature

**OAH 003 G D A C**

<p><b>Model</b> _____</p> <p>OAH = Custom modular air handler OAC = Custom modular component</p> <p><b>Nominal unit size</b> _____</p> <p>(cataloged size—nominal square foot of coil) 003, 004, 006, 008, 010, 012, 014, 017, 021, 025, 030, 035, 040, 050, 065, 080, 085, 090</p> <p><b>Vintage of Daikin Applied air handling unit</b> _____</p> <p><b>Unit type/coil position</b> _____</p> <p>B = Blow-through cooling coil location D = Draw-through cooling coil location H = Heating only V = Vent only M = Multizone</p>	<p><b>Unit cross section</b></p> <p>C = Standard unit cross section M = Custom size cross section</p> <p><b>Motor location</b></p> <p>A = Motor along side of fan housing C = Motor downstream of ECM fan D = Motor downstream of belt-drive plenum fan G = Motor downstream of direct-drive plenum fan H = Motor downstream of direct-drive plenum fan in fan array T = Motor behind twin fan housing</p>
---	--

## Hazard Identification Information

**⚠ DANGER**

Dangers indicate a hazardous situation which will result in death or serious personal injury if not avoided.

**⚠ WARNING**

Warnings indicate potentially hazardous situations, which can result in property damage, severe personal injury, or death if not avoided.



**⚠ CAUTION**


Cautions indicate potentially hazardous situations, which can result in personal injury or equipment damage if not avoided.

**NOTICE**

Notice indicates practices not related to personal injury.

## A2L Refrigerants (if applicable)

 <b>WARNING</b>	
	<p><b>A2L</b></p> <p>This unit contains either R-32 or R-454b, both are class A2L refrigerants that are flammable. This unit should only be installed, serviced, repaired, and disposed of by qualified personnel licensed or certified in their jurisdiction to work with A2L refrigerants. Installation and maintenance must be done in accordance with this manual. Improper handling of this equipment can cause equipment damage, personal injury, or equipment damage.</p>
<p>Be aware that R-32 and R-454b refrigerant may not contain an odor. Place in a well ventilated area to prevent accumulation of refrigerant. When installing the unit in a small room, take measures to keep the refrigerant concentration from exceeding allowable safety limits. Excessive refrigerant leaks, in the event of an accident in a closed ambient space, can lead to oxygen deficiency.</p> <p>Do not pierce or burn this unit.</p> <p>Never use an open flame during service or repair. Never store in a room with continuously operating ignition sources (for example: open flames, an operating gas appliance, or an operating electric heater.), where there is ignitable dust suspension in the air, or where volatile flammables such as thinner or gasoline are handled.</p> <p>Only use pipes, nuts, and tools intended for exclusive use with the unit's designated A2L refrigerant in compliance with national codes (ASHRAE15 or IRC).</p> <p>Do not mix air or gas other than the unit's designated A2L refrigerant in the refrigerant system.</p> <p>Do not use means to accelerate the defrosting process or to clean, other than those recommended by the manufacturer.</p> <p>The unit shall be stored in a room without continuously operating ignition sources (for example: open flames, an operating gas appliance, or an operating electric heater).</p>	

 <b>WARNING</b>
<p>When moving flammable A2L refrigerant to/from the unit from an auxiliary tank, a grounding strap must be used. An electrical charge builds when halo-carbon refrigerant travels in a rubber hose. A grounding strap must be used between the auxiliary refrigerant tank and the unit's end sheet (earth ground), which will safely take the charge to the ground. A fire risk could occur if this procedure is not followed.</p>

## Unit Nameplate

The unit nameplate is located on the outside of the main control box door. It includes the unit model number, serial number, electrical characteristics, and refrigerant charge.

## Compliance Statements







Depending on the unit configuration, the unit will come with either a Fused Disconnect, a Non-Fused Disconnect, a power block, or a combination in cases where multiple sources of power are specified. Consult the Unit Specific Electrical Schematics to determine the number of required sources of power. Refer to [See Electrical Installation on page 35](#) for the standard multiple point power connection options and their function.

This appliance is not intended for use by persons (including children) with reduced physical, sensory, or mental capabilities, or lack of experience and knowledge, unless they have been given supervision or instruction concerning use of the appliance by a person responsible for their safety.

NOTICE
<p>Unit/equipment must be installed in a location that is not accessible to the general public.</p>

## Unit Labels

Pictogram warning and informational labels may be present on the unit. Consult the table below for reference.

Label	Description
 <p>Refrigerant class per ISO 817</p>	<b>WARNING - flammable refrigerant present</b>
	Read the technical manual for service instructions
	WARNING - A2L low-burning velocity refrigerant present
	Pressurized medium present
	Ultraviolet (UV) radiation present
	Read the technical manual for instructions

## Receiving and Handling

### Inspection

Carefully check equipment against the bill of lading to ensure all items have been received. Before unloading any unit, check the nameplate to make sure the voltage complies with the power supply available.

Inspect all units for damage upon arrival. If a unit has become dirty during shipment, carefully clean it prior to completing the inspection. Daikin Applied is not responsible for physical damage after the unit leaves the factory unless the contract with Daikin Applied states otherwise.

### NOTICE

All units should be carefully inspected for damage when received. Report all loss or shipping damage using a claim form supplied by Daikin Applied.

**VISIBLE LOSS OR DAMAGE:** Any external evidence of loss or damage must be noted on the freight bill or carrier's receipt, and signed by the carrier's agent. Failure to adequately describe such external evidence of loss or damage may result in the carrier's refusal to honor a damage claim.

**CONCEALED LOSS OR DAMAGE:** Concealed loss or damage means loss or damage which does not become apparent until the unit has been unpacked or unwrapped. The contents may be damaged in transit due to rough handling even though the exterior may not show damages. When the damage is discovered, make a written request for inspection by the carrier's agent within **five (5) days** of the delivery date and file a claim with the form provided by Daikin Applied. Refer to the Daikin Applied Freight Policy for further information.

### Packaging

- All shipping wrap material, including stretch and shrink wrap, must be removed upon unit arrival. This wrapping is for transit protection only. Units are not to be stored with wrapping material left on, as white rust will develop if any moisture is present.
- Field-installed components, such as vestibules or shipped loose controls, will ship on separate skid(s).
- Hardware (screws, bolts, etc.) for assembling sections are supplied in a bag attached to each section.

**NOTE:** A special #30 Torx bit is required for assembly.

### Identification

- Every shipping section includes a nameplate identifying the customer tagging information, unit serial number, unit order number, and the shipping section position for installation.

## Handling

- Skyline air handler units are constructed of painted or galvanized steel and are inspected thoroughly before leaving the factory. Take care during installation to prevent damage to units. Do not stand or walk on top of units.
- Air handler bases are designed with the necessary number of lifting points for safe installation. All lifting locations must be used.
- Take special care when handling blower sections. All fans are dynamically balanced before leaving the factory. Rough handling can cause misalignment or a damaged bearings or shaft. Carefully inspect fans and shaft before unit installation to verify this has not happened.

## Unit Storage

- Skyline units may be stored outdoors. Follow the below instructions to ensure proper storage. Any damage to the unit resulting from improper storage will not be covered by Daikin Applied.
- Ensure no moisture, debris, or minerals are on the unit prior to storage, as these can cause permanent damage to the cabinet and components.
- Store units in a clean, dry environment on a level surface. Ensure units are on a dry surface or raised off the ground to protect components from any standing water; ensure adequate support is used to prevent the unit or section base from sagging, if raised.
- All openings, including dampers and bottom openings, must be covered to protect from rain, snow, dust, and animals. Do not use plastic tarps to cover the unit, as condensation can form on the air handler resulting in corrosion or stains. Use only canvas tarps to ensure the inside of the unit remains clean, dry, and ventilated. Do not allow coverings to trap moisture on surfaces.
- All tarps should be inspected frequently to ensure the integrity of the tarp is maintained and to prevent damage to the unit by the elements. Any damage to the tarp should be repaired immediately.
- It is recommended that the unit interior be inspected daily to observe whether condensation is occurring and if temporary or routine ventilation of the interior is needed to control condensation. Units should be inspected at different times of the day to ensure varying weather conditions are not causing condensate to occur.
- All shipping wrap material, including stretch and shrink wrap, must be removed upon unit arrival. Units are not to be stored with wrapping material left on, as white rust will develop if any moisture is present.
- A field-supplied desiccant bag may be hung in the interior of the unit to minimize corrosion in humid storage environments.
- Do not stack sections or store anything on top of units.
- Isolate unit from shock and vibration.
- Do not clean galvanized steel surfaces with oil dissolving chemicals. This may remove the protective coating and accelerate corrosion.

- Pack fan and motor bearings (unless motor bearings are sealed) with compatible grease while the fan shaft is stationary. After grease has been installed, rotate shaft a minimum of 10 rotations.
- Once a month, rotate shaft a minimum of 10 revolutions. Ensure the stopped position is different than the original position.
- Coat shafts with lubricant as needed to prevent corrosion.
- Inspect all doors and openings once a month to ensure they are closed and properly sealed.
- Loosen belt tension on belt-driven fans, if storing for more than two (2) months.

### Belt driven fans:

- Reduce belt tension by at least 50% or remove the belts. Remove belts if they will be subjected to temperatures exceeding 85°F to avoid deterioration.
- Remove belt guard when adjusting belts.
- Reduce belt tension prior to removing or installing belts. Removing or installing tensioned belts may cause personal injury and damage to the sheaves, belts, bearings or shafts.
- Adjustable sheaves should be opened as wide as possible and the adjustment threads lubricated so they do not corrode. Be careful not to put lubricant on the belt running surface.

### Prior to start up:

- Set screws on bearings, fan wheels, and sheaves need to be checked for proper torque. Also check bolt torque for any taper lock hubs either on the wheel or sheaves.
- Check sheaves for corrosion. Significant corrosion can cause belt or sheave failure.
- Purge old grease from fan bearings while rotating the shaft to distribute the new grease evenly and prevent bearing seal failure.
- Correctly align and tension belts. [See General Rules of Tensioning on page 62.](#)

## Gas Furnace

For installation and maintenance information related to gas heat, refer to [IM 1300](#).

# Mechanical Installation

## Lifting Guidance

Daikin Applied equipment is designed to withstand the loads of the lifting and rigging process resulting from ASME Standard P30.1 - Planning for Load Handling Activities or equivalent. Lifting guidance is intended for installations of newly delivered equipment. If moving previously installed equipment for re-location or disposal, consideration should be given to unit condition. Equipment should also be drained as unit weight and center of gravity values do not reflect the addition of water for lifting.

**⚠ DANGER**

Improper rigging, lifting, or moving of a unit can result in unit damage, property damage, severe personal injury, or death. See the as-designed, certified dimensioned drawings included in the job submittal for the weights and center of gravity of the unit. If the drawings are not available, consult the local Daikin Applied sales office for assistance.

Installation is to be performed only by qualified personnel who are familiar with local codes and regulations, and experienced with this type of equipment. Lifting equipment and mechanisms must be determined by the Lifting Director per the current version of ASME Standard P30.1 or equivalent and must be suited for the load capacity. Daikin Applied is not a licensed nor certified rigging specialist. Therefore it is the customer's responsibility to consult a certified rigging contractor to rig, lift, and move components and subcomponents properly and safely as needed.

**⚠ CAUTION**

Forklifts may not be used to lift or move ship sections as the method may result in unit damage.

**⚠ CAUTION**

When around sharp edges, wear appropriate Personal Protective Equipment (PPE), such as gloves, protective clothing, foot wear, eye protection, etc., to prevent personal injury.

### Lifting Brackets

Lifting brackets on Skyline ship sections have a 2" diameter hole. For Skyline sections on a standard base or curb-ready base, the lifting brackets are located at each corner of the base. For Skyline units on a unitized base, the lifting brackets are located along the face of the base rail, the front, and the back. There are 4, 6, or 8 depending on the length.

Skyline piping vestibules on a unitized base are shipped separate from the unit and are lifted from 4 lifting brackets on the top corners. Each has a 1.25" diameter hole.

Engagement with each bracket is to be as close to vertical as possible. The maximum allowable lift angle from the vertical is 30 degrees as shown in Figure 2. If the lift angle shifts beyond 30° from vertical on any of the lift points, the lift shall not proceed until a plan and rigging can be secured that will correct the angle of lift.

**⚠ WARNING**

The lifting angle must not go beyond 30 degrees from vertical or the unit can become unstable which may result in unit damage, property damage, severe personal injury, or death.

Figure 1: Illustration of Lifting Bracket and Allowed Angle for Lifting

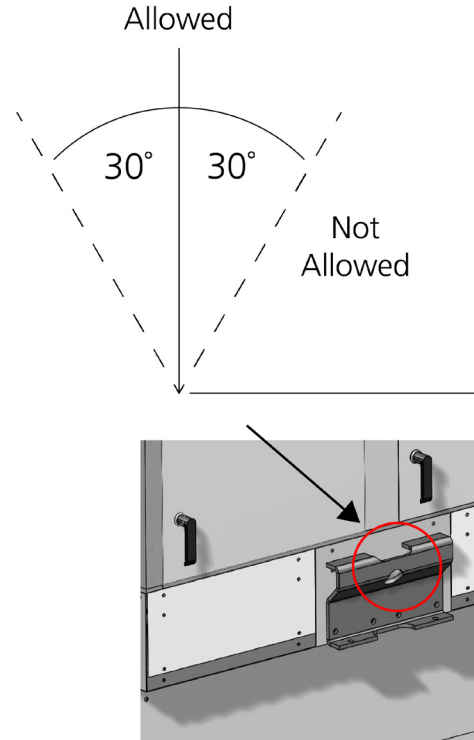


Figure 2: Illustration of Allowed Angle Label

**⚠ WARNING**

**All factory provided lifting points must be used. Unit must remain level during lift and transit!**

The lifting strap angle must not go beyond 30 degrees from vertical or the unit can become unstable which may result in unit damage, property damage or severe personal injury or death.

## Lifting Equipment

Lifting equipment is supplied by the user or their designate. This is typically selected around the unit certified information of the equipment to be lifted and the available lifting equipment planned to be at the site where the lift is to take place. It is the responsibility of the Lifting Director to follow a standard practice of lift planning and equipment selection, like that found in the ASME P30 series of standards. Lifting plan and equipment must ensure that the only contact with the unit is at that lifting brackets. Straps, chains or spreader bars that are likely to be used shall not come in contact with the unit.

### ⚠ CAUTION

Lifting mechanisms must not make contact with the unit beyond the lifting bracket. Extreme care must be used when rigging the unit to prevent damage to the control panels, unit handles, unit piping, and unit frame.

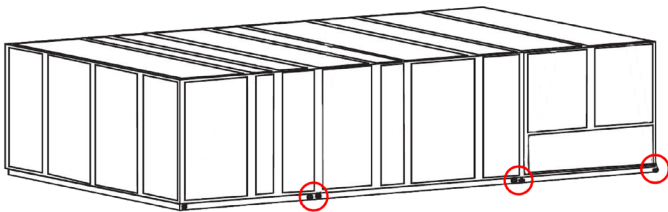
## Lifting Points

Lifting points are predetermined by design. When lifting, all factory installed lifting brackets must be used. Unit must remain level throughout the entire lifting event. Level is defined as one end being no more than 0.25" per foot of unit length to the opposite end.

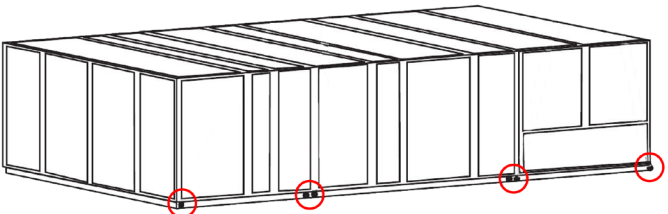
### ⚠ WARNING

Be aware that the center of gravity may not necessarily be in the geometric center of the unit. No additional items can be added to a lift with the unit as it may affect the center of gravity and cause unit damage, property damage, severe personal injury, or death. Refer to as-designed, certified drawings for weight, center of gravity location and details specific to unit configuration.

**Figure 3: Six-Point Rigging Example**



**Figure 4: Eight-Point Rigging Example**



## Transit and Temporary Storage

If the unit is stored for an intermediate period before installation or moved to a different location, take these additional precautions:

1. Support the unit well along the length of the base rail.
2. Level the unit (no twists or uneven ground surface).
3. Provide proper drainage around the unit to prevent flooding of the equipment.
4. Provide adequate protection from vandalism, mechanical contact, etc.
5. Securely close the doors and lock the handles.
6. If there are isolation dampers, make sure they are properly installed and fully closed to prevent the entry of animals and debris through the supply and return air openings.
7. Cover the supply and return air openings on units without isolation dampers.
8. Long term storage in humid environments may cause condensate corrosion on steel surfaces. Consider adding a desiccant material to alleviate corrosion concerns.

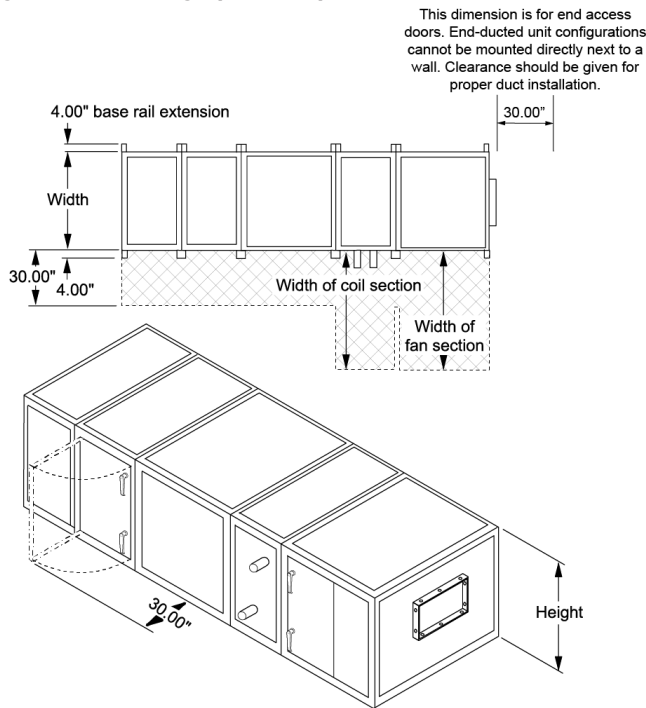
Shimming of the unit under the lifting brackets or tie-down points must be used to ensure even contact along the length of the base rail.

## Service Clearances

In addition to providing adequate space around the unit for piping coils and drains, access to at least one side of the unit is always required to allow for regular service and routine maintenance, which includes filter replacement, drain pan inspection and cleaning, fan bearing lubrication, and belt adjustment. Provide sufficient space—at least equal to the length of the coil—on the side of the unit for coil removal. See [Figure 5](#) for servicing space requirements.

Maintain at least 54" of clearance in front of electrical power devices. Electrical power devices that are mounted on the side of the unit typically are up to 12" deep. Fan sections with multiple fans have motor control boxes up to 16" deep when supplied with VFDs.

**Figure 5: Servicing Space Requirements**



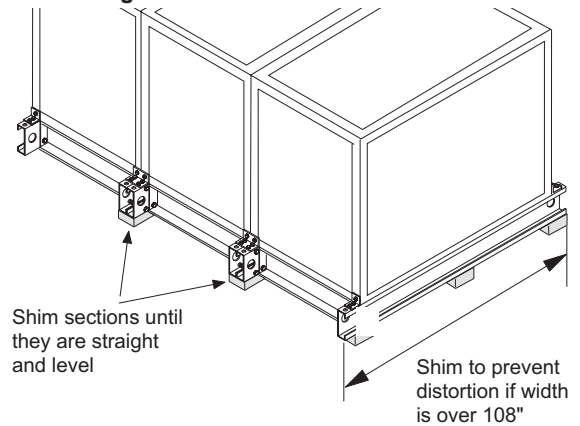
## Curb Mounting and Unit Leveling

Do not place a Skyline unit over an open curb unless it is equipped with a curb-ready base. Installation instructions for mounting units on a roof curb are provided in [IM 770](#). For a copy, contact your local Daikin Applied representative or visit [www.DaikinApplied.com](http://www.DaikinApplied.com). Make provisions under the unit to divert any moisture from entering the building below.

For units without roof curb mounting, place the equipment on a flat and level surface. Where surface irregularities exist, shim the base of the unit at one or more points along the length of the rails to prevent distortion or sagging of the support rails. Uneven or distorted sections cause misfit or binding of the doors and panels and improper draining of drain pans ([Figure 6](#)).

If the unit is supported on rails they must be placed around the entire perimeter. Additional Supports must be placed perpendicular to airflow spanning the full width of the unit at all shipping splits. If the unit is over 107" wide these supports must also be placed at the entering and leaving edges of fan and cooling coil sections. The perimeter rails must be at least 2" wide at the top and capable of carrying the entire weight of the unit. The cross supports must be 4" wide at the top and capable of carrying the weight of the two sections it spans. The cross supports shall be placed such that 2" of the top is supporting each section. The perimeter rails shall be placed so that they are fully supporting the outer 2" of the unit. If shims are required they must be placed such that the unit is fully supported.

**Figure 6: Leveling the Unit**



## Assembling Sections

If the unit is shipped in more than one shipping section, rig each section into position separately. Shipping sections are provided with a connection splice joint attached to the cabinet which seals against the gasket of the frame channel on the adjoining shipping section. The splice joint provides an air seal between two sections once they are assembled together. Some unit configurations require multiple splice joints on the same face or on opposing faces of a single section. Confirm correct placement and orientation of unit sections and splice joints based on included unit drawings. Align all splice joints to seat into the mating gasket to provide an air seal. If the splice joint was bent during shipping or rigging, restore it to its original position (Figure 13). For high pressure low leakage units, ensure that the D-gasket is attached to the entering air side frame channel (Figure 14). If it dislodged during shipping, restore it to its designed position. Note: Some sections are shipped with shipping braces. These need to be removed before connecting the shipping sections.

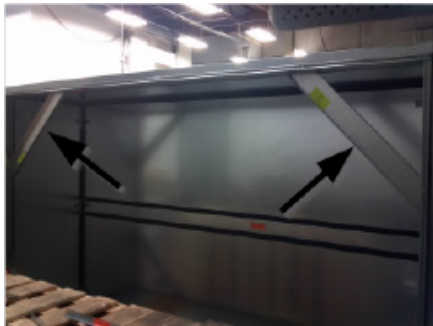
### NOTICE

Splice collars are built with foam inserts that should NOT be removed during installation (see Figure 7).

Figure 7: Foam Inserts



Figure 8: Shipping Braces



## Shipping Sections

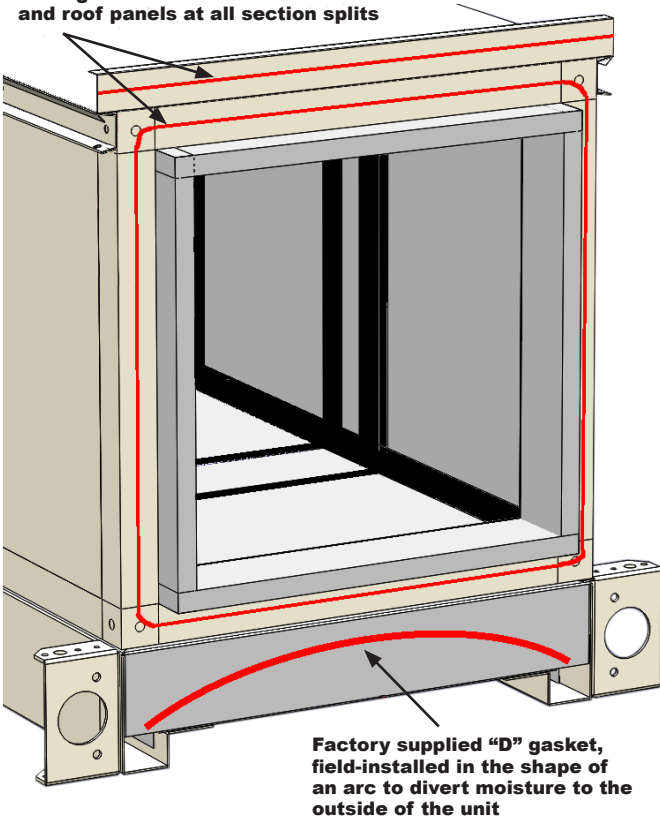
### NOTICE

The factory supplied D gasket must be field installed prior to pulling ship sections together. Install D gasket at all section splits on the mating face of the base rail in an arc shape with the ends lower than the center, so that any moisture that may reach the gasket will be drained to the outside of the unit. (Figure 11).

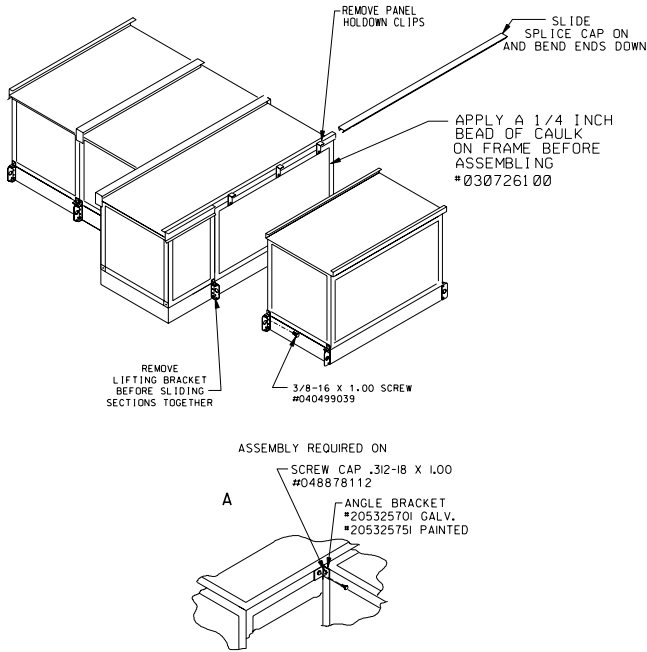
1. Add a lubricant to top of curb gasket to allow sections to slide together easier.
2. Apply a minimum 1/4" bead of caulk to the mating faces of frame channels and roof panels at all section splits of the unit before joining the sections together. Also adhere the factory supplied, field installed "D" Gasket to the mating face of the base rail at all section splits in the shape of an arc to divert any moisture to the outside of the unit. (Figure 9).
3. Ensure the splice collar lines up with the opening in the mating section. Use clamps or threaded rod at the base lifting lugs to pull the sections closer. Be careful to not damage them. Use the 3/8"-16 x 1" bolts located in the splice kit provided with each ship section of the unit to pull the bases together via the holes in the lifting lugs. (Figure 11). Use ratchet straps to pull the top of sections together.
  - a. To fasten two shipping sections together, eight nuts and bolts are required (two on the top, two on the bottom on each side of the unit) which are factory supplied in the splice kits with each unit. Complete each section top and bottom before attaching additional sections. (Figure 11).
  - b. If the bottom internal splice collar gap is larger than 1/4", add sealant to that gap.
  - c. For sections with vestibules, after the vestibule section is on the curb, remove the vestibule lifting brackets and slide sections together. (Figure 10).
  - d. For certain high pressure low leakage units, use the provided section joining plates to fasten sections together. Space them as shown in Figure 12. Using the provided 1/4"-14 x 1" self tapping screws, drill screw the joining plates into the frame channel on each section, keeping unit sections tight together. Follow instruction drawing included in the assembly kit.
4. After sections are seated tightly together, add caulk to the external section split joint from top to bottom. **DO NOT** caulk the bottom of the base rail at the section split. This seam acts as a weep hole.
5. After sections are seated tightly together, add caulk to fill the seam between the roof panels at each end. Slide the splice cap over the top panel flanges. Bend the ends of the splice cap down to secure in place (Figure 15).
6. Assemble the small splice plate at the top rail to secure the sections together at the top. Use 5/16" bolts (Figure 15).

**Figure 9: Apply Sealant to Mating Faces**

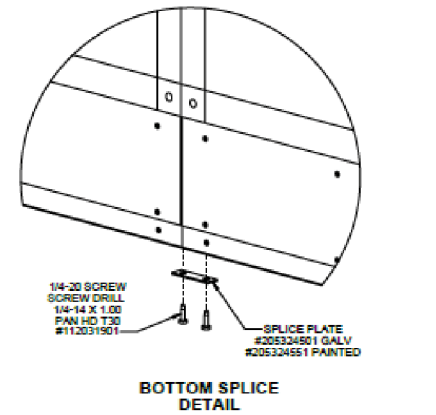
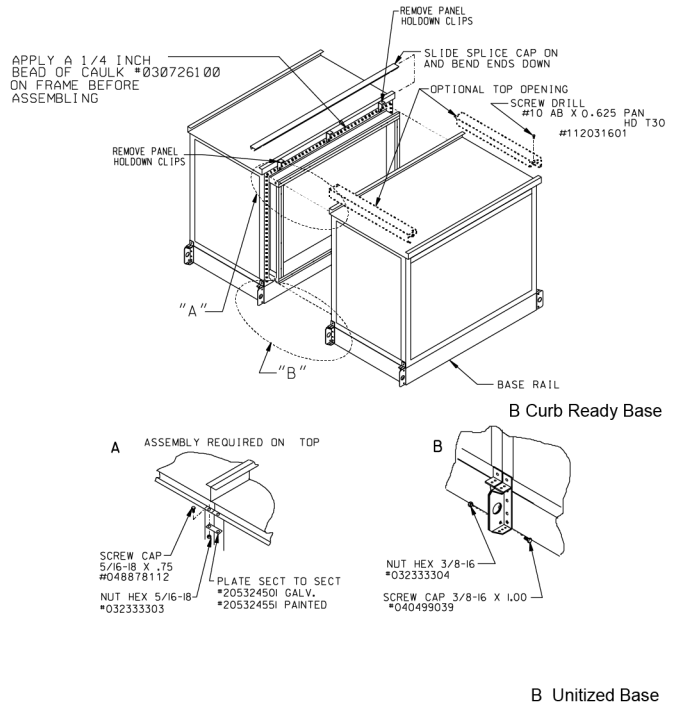
Add minimum 1/4" bead of caulk on mating faces of frame channels and roof panels at all section splits



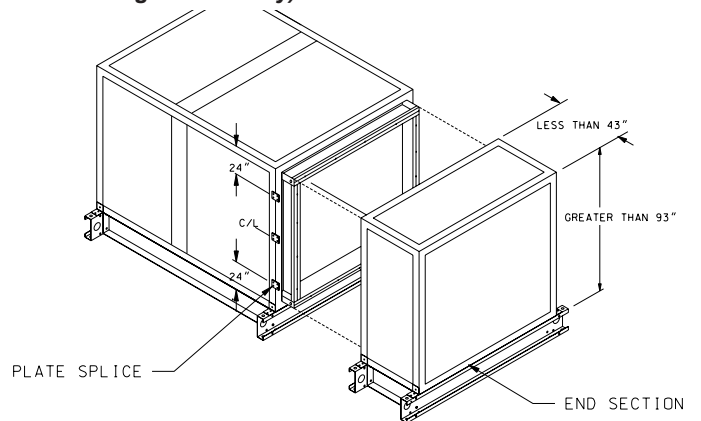
**Figure 10: Sections with Vestibules**



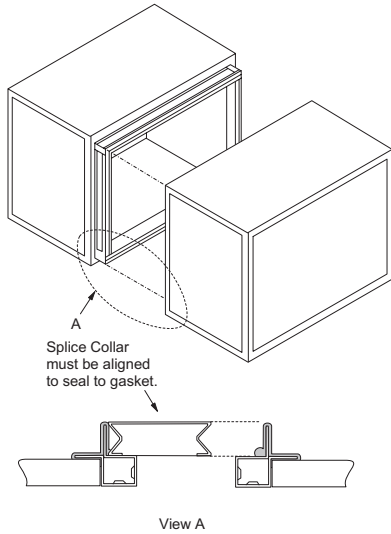
**Figure 11: Fasten Sections Together**



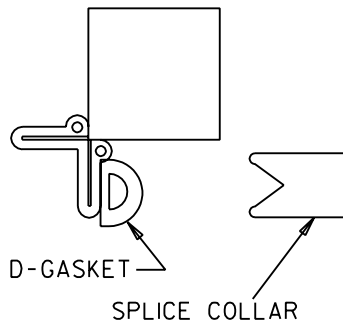
**Figure 12: Frame Channel Stiffener Plates (High Pressure Low Leakage Units Only)**



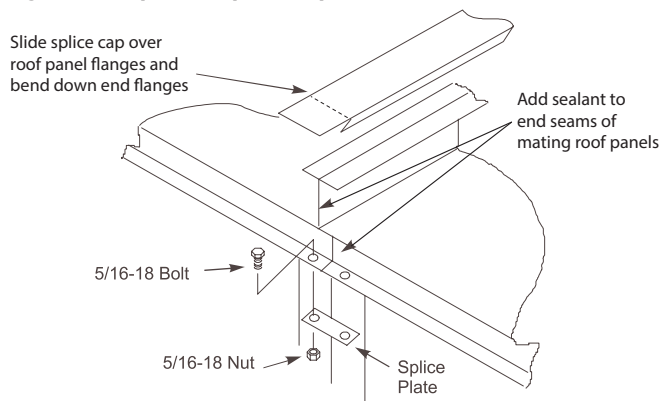
**Figure 13: Splice Collar Alignment**



**Figure 14: D-Gasket Placement Detail (High Pressure Low Leakage Units Only)**



**Figure 15: Splice Cap and Splice Plate**



## Panels, Frame Channels, and Doors

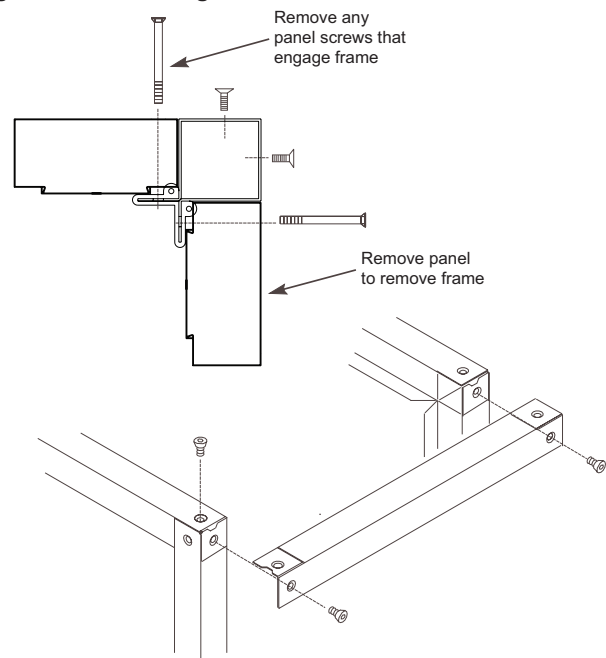
### Panel Removal

To remove a side or top panel, remove the flat head Torx 30 fasteners along the sides of the panel. Lift off the panel after removing all fasteners.

### Frame Channel Removal

Frame channels that run the length of the unit along the top can be removed to allow access to both the side and top of the unit. To remove the frame channel, first remove the side panel(s). Once the side panel is off, remove the flat head Torx 30 fasteners in the corner of the frame channels. Then pull the frame channel out the side. Remove any panel screws that are within one inch of the of the frame since they are engaged into the gasketed flange of the frame (Figure 16).

**Figure 16: Removing Panel Screws**



### Access Doors and Panels

For routine maintenance, access normally is obtained through access doors or by removing side panels. Removing all flat head fasteners along the sides of a panel allow it to be removed.

Fan and filter sections are always provided with a service door on one side of the unit. If requested on order, doors can be provided on both sides of the unit. Optional service doors are available for most section types and are provided based on customer request.

## Fan Section Doors

**WARNING**

Sharp edges and coil surfaces are a potential injury hazard. Avoid contact.

**NOTE:** Opening fan section doors requires using a 17 mm socket wrench (Figure 17), which satisfies ANSI standards and other codes that require the “use of tools” to access compartments containing moving parts or electrical wiring.

Figure 17: Opening Fan Section Door

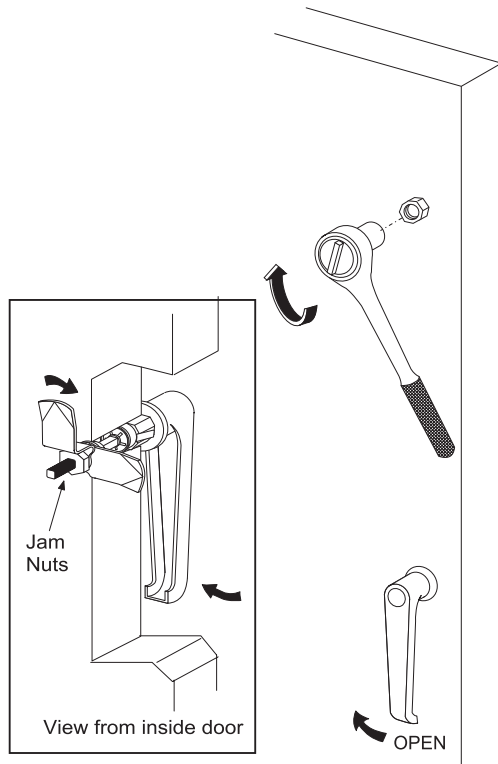
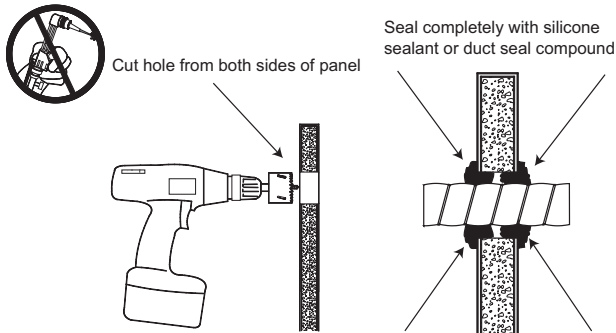


Figure 18: Cutting/Sealing Injected-Foam Insulated Panels



Prop 65—Substances in fuel or from fuel combustion can cause personal injury or death, and are known to the State of California to cause cancer, birth defects or other reproductive harm.

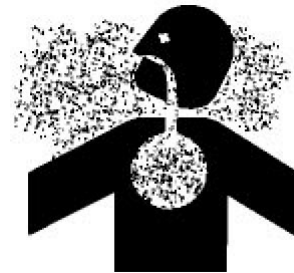
## Injected-Foam Insulated Panels

Skyline air handlers now are furnished with double-wall, injected-foam insulated panels. Foam panels are stronger, more rigid, and lighter than panels with fiberglass insulation. The insulation R-value is improved to 13. However, foam insulation can burn when exposed to flame or other ignition sources and release toxic fumes. Take care in cutting and sealing all field-cut openings in these panels.

### Panel Cutting Procedure

**WARNING**

Flame and smoke can cause equipment damage, severe personal injury, or death. Before operating unit, seal all piping and wiring holes on both inner and outer panels with an industrial grade silicone sealant or duct seal compound. Do not use a cutting torch or expose panel to fire. Panel damage can occur.



1. Determine the number and location of holes required for electrical conduit, piping, and control wiring as follows:
  - a. Check that adequate space is available inside the unit for conduit or pipe routing.
  - b. Do not locate holes in a panel that provides access to key maintenance components such as filters and fan assemblies.
  - c. Do not locate where the conduit or piping blocks airflow or obstructs hinged access doors.
2. Once a proper location is determined, drill a small pilot hole completely through the panel. Then use a sharp hole saw or a saber saw and cut from each side of the panel.
3. Seal the double-wall panel on each side with an industrial/commercial grade silicone sealant or duct seal compound. It is extremely important to seal each panel hole or penetration securely so it is airtight, watertight, and so that there is no exposed insulation.

## Field Mounting Junction Boxes / Other Components

For field mounting 4" x 4" or smaller junction boxes to the standard panel exterior, use a minimum quantity of four, 3/16" diameter pop rivets. **Do not use self-tapping drill screws. They will not tighten nor secure properly and panel damage can occur.**

If larger, heavier components require mounting on unit panels, use through-bolts with flat washers through both outer and inner panels. To maintain panel integrity, seal both ends with an industrial/commercial grade silicone sealant or duct seal compound.

The unit frame channel is another excellent location for securing heavier components; self-tapping screws are not acceptable. Ensure that the location permits the full operation of all access doors and panels and does not interfere with other vital components.

## HEPA Holding Frame, Filter, and Prefilter Installation

These instructions are for installing AAF HEPA filters (11-1/2" depth) into AAF HEPA Holding Frames.

Please read the entire installation instructions before beginning the installation process.

Install filters into the HEPA Holding Frames only after the frames have been securely installed into existing ductwork or housing. Frames should be bolted or pop riveted together into the permanent structure through the pre-drilled holes around the outside perimeter of the frames. Frames should be sufficiently caulked and sealed to prevent any air bypass or leakage.

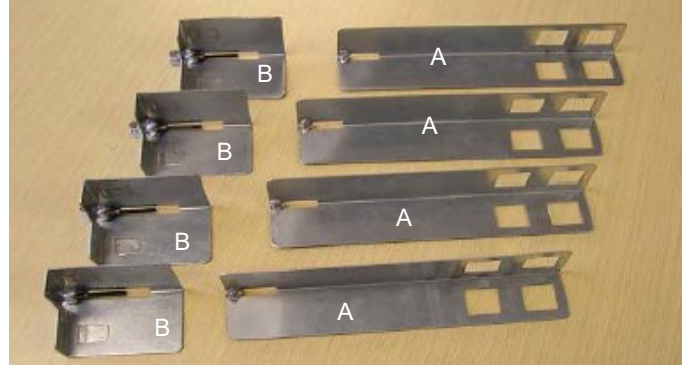
### Required tools for filter installation:

- T-handle Hexkey, size 5/32"

**Figure 19: Required Framing Components**

Component(s)	Daikin Applied PN
AAF HEPA Holding Frames	910111491 910111674
Leg Extensions, 4 per frame (A)	910111494
Latches, 4 per frame	910111493 (B) (without prefilters) 910123164 (C) (with prefilters)
Prefilter Holding Frames (when prefilters are ordered)	910123166 910123168
Prefilter Latches (when prefilters are ordered)	111048304 111048305

**Figure 20: Leg Extensions and Latches without Prefilters**



**Figure 21: Leg Extensions and Latches with Prefilters**

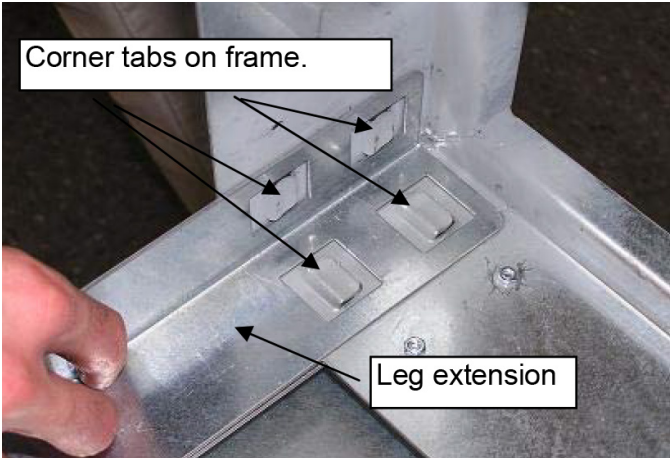


## AAF HEPA Filters without Prefilters

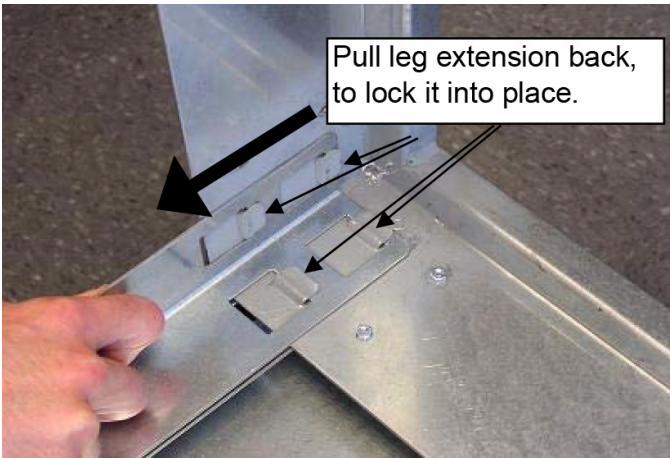
**STEP 1:** At the inside corner of each frame are 4 tabs, 2 per side. Place a leg extension over the 4 tabs as shown in [Figure 22](#), then pull back on the leg extension locking it into place ([Figure 23](#)).

Repeat Step 1 with each of the 4 corners. The frame with leg extensions should look like [Figure 24](#).

**Figure 22: Place Leg Extension over the Frame Tabs**



**Figure 23: Pull Back to Lock the Leg Extension into Place**



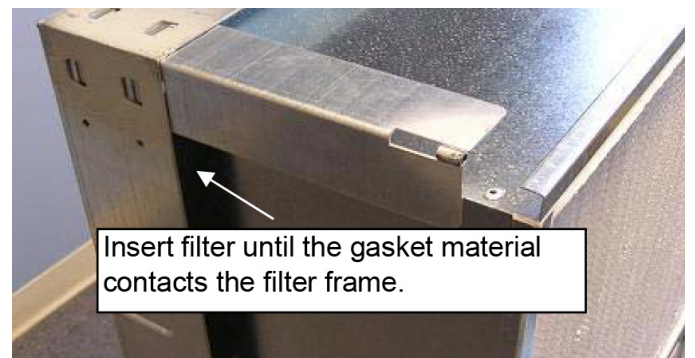
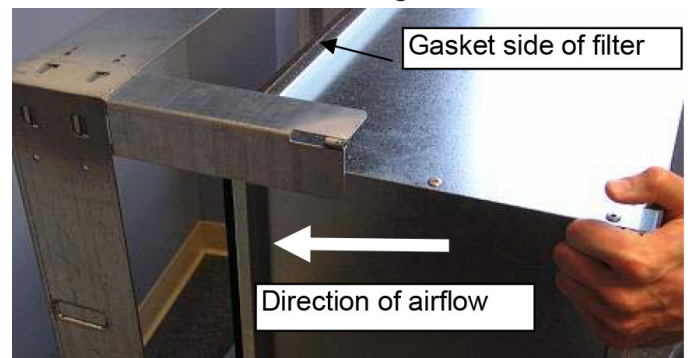
**STEP 2:** Insert the HEPA filter into the HEPA Holding Frame. The HEPA should be installed with the gasket side of the filter facing the frame. Insert the filter as far into the frame as possible, so that the gasket material is contacting the frame. See [Figure 25](#).

The filter should now be resting inside of the holding frame. When installing the filters into a frame bank of multiple frames, install the lower filters first so that the upper filters can rest on the lower filters ([Figure 26](#)).

**Figure 24: Frame with Leg Extensions Installed**



**Figure 25: Insert HEPA Filter into Frame, until the Gasket Comes in Contact with the Holding Frame**

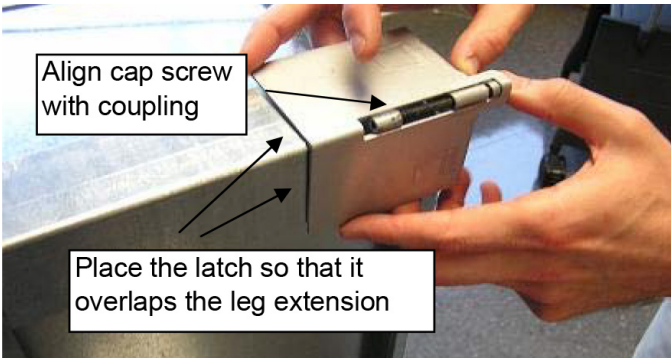


**STEP 3:** Place a latch so that it overlaps the leg extension, as shown in [Figure 27](#). Align the latches' cap screw with the threaded coupling on the end of the leg extension and tighten using the hexkey. Tighten the cap screw until there is an approximately 1/4" gap between the latch and the leg extension coupling as shown in [Figure 28](#). Repeat this step with all 4 corners.

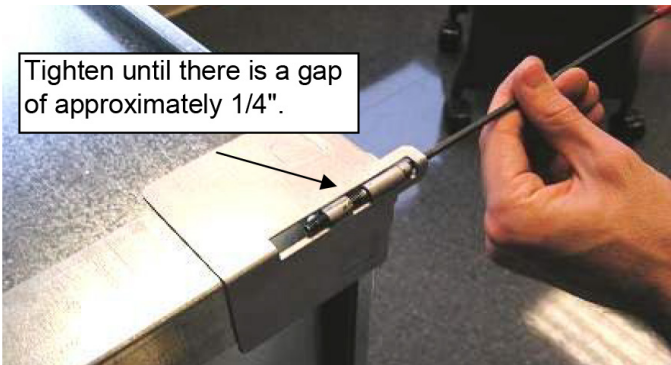
**Figure 26: Filter Placed Inside of Frame**



**Figure 27: Latch Overlapping Leg Extension**



**Figure 28: Tighten Cap Screw to 1/4" of the Coupling**

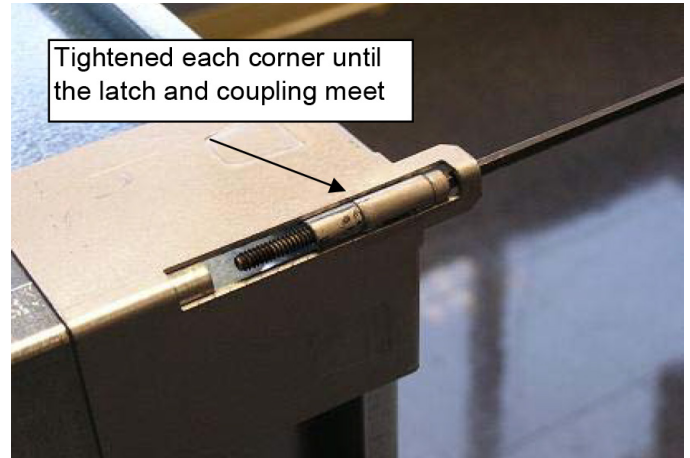


**STEP 4:** Once all four corner latches have been tightened within 1/4" of the leg extension coupling, complete the installation by tightening each corner until the latch and leg extension coupling meet. This is illustrated in [Figure 29](#).

Once all four corners have been tightened the filter should now be properly seated and sealed.

Repeat the process with all remaining filters working from the bottom to the top.

**Figure 29: Tighten until Latch and Coupling Meet**



**Figure 30: Properly Installed Filter Inside of the Frame**



## AAF HEPA Filters with Prefilters

Follow previous steps 1-2, then continue straight to step 5.

**STEP 5:** The prefilter holding frame should be placed directly in front of the HEPA filter as shown in [Figure 31](#).

**Figure 31: Positioning of the Prefilter Frame**

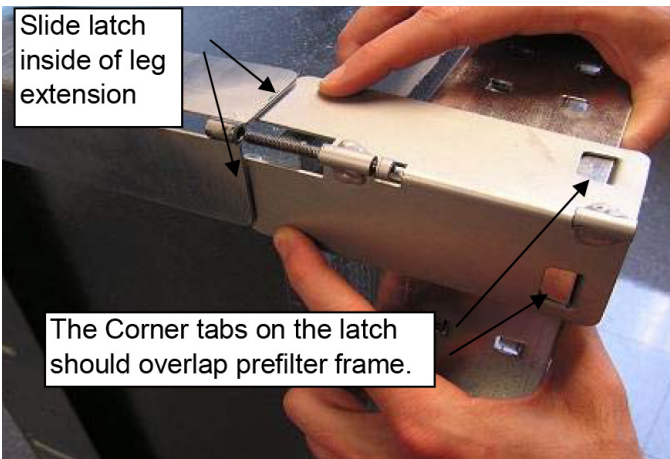


**STEP 6:** Place a latch so that the 2 tabs of the latch overlap the prefilter frame on each side of the corner. Slide the latch inside of the leg extension and align the latches' cap screw with the threaded coupling on the end of the leg extension and tighten using the hexkey. See [Figure 32](#).

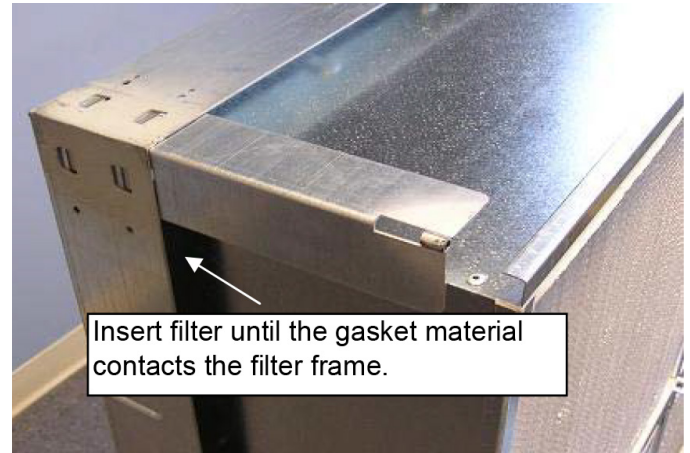
Tighten the cap screw until there is an approximately 1/4" gap between the latch and the leg extension coupling as shown in [Figure 33](#). Repeat this step with all 4 corners.

**STEP 7:** Once all four corner latches have been tightened within 1/4" of the leg extension coupling, tighten each corner until the latch and leg extension coupling meet. This is shown in [Figure 34](#).

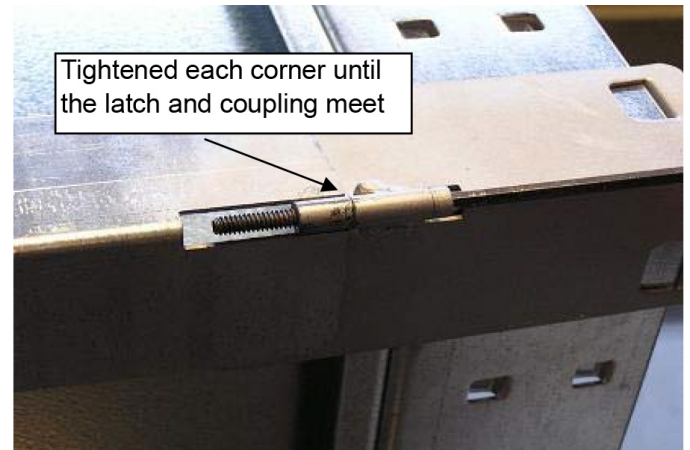
**Figure 32: Latch Positioning for Prefilter Frame**



**Figure 33: Tighten Cap Screw to 1/4" of the Coupling**



**Figure 34: Tighten until Latch and Coupling Meet**



Once all four corners have been tightened the HEPA filter should now be properly seated and sealed.

Repeat the process with all remaining filters working from the bottom to the top.

**Figure 35: Properly Installed HEPA Filter**



**STEP 8:** To complete the installation, add the appropriate prefilter latches to the prefilter holding frame. Once latches are installed, place the prefilter in the frame, secure with the latches and the installation is complete.

Repeat with all remaining prefilters and frames.

**Figure 36: Installation of Prefilter into Frame**



**Figure 37: Completed Assembly**

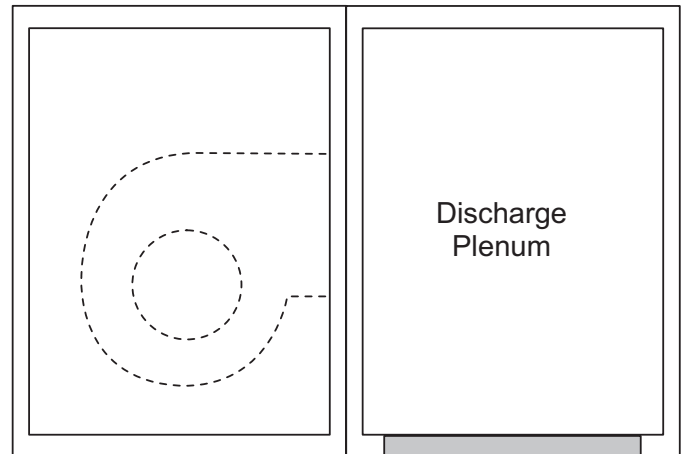


## Duct Connections

Use flexible connectors on the outlet and inlet duct connections of all units. Do not position down flow fans over air ducts that are routed down into the building. Use a discharge plenum when bottom connections are necessary (Figure 38).

Support all ductwork independently of the unit or unit casing.

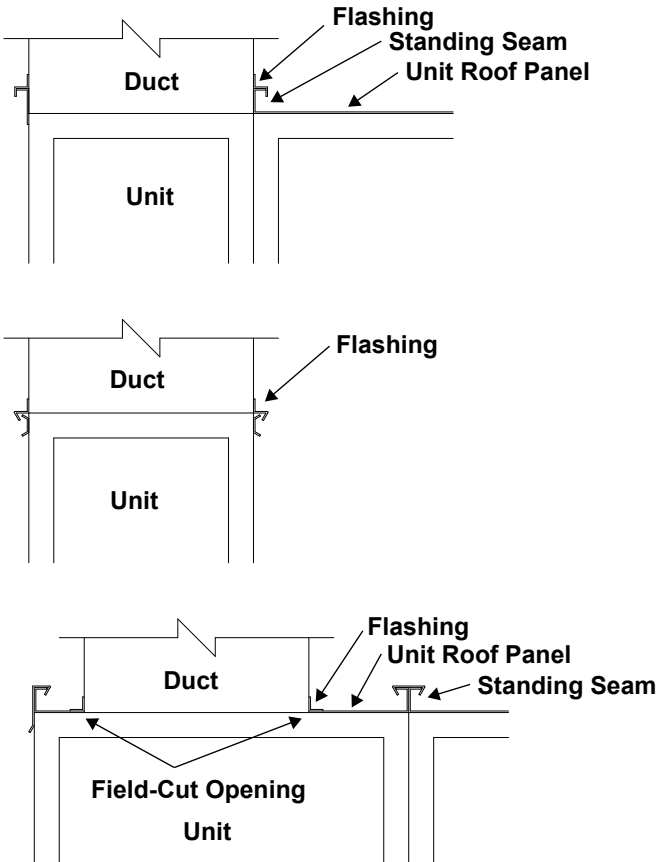
**Figure 38: Discharge Plenum**



If the unit has a section with a top opening, field fabricate and install flashing to seal out and divert any moisture away from the opening, ductwork, or duct components attaching to the opening. Install flashing so that it laps over the standing seams of the unit roof panels and over the side edges of the unit (Figure 39). Connect ductwork to the unit itself - do not connect ductwork directly to the unit roof panel only. Seal the ductwork to the opening, the unit itself, and to the unit roof panel to prevent moisture intrusion into the unit or building.

**NOTE:** A full roof panel will be included above top openings or top dampers. Field cut an opening of the desired size taking care to avoid damaging unit panels, flanges, dampers, or any other internal components while cutting. Roof panel(s) may be removed to facilitate cutting, sealing, and flashing connections but must be replaced and resealed in a way that diverts moisture away from the opening and connected ductwork. Ductwork must be sealed and flashed to the opening, the unit itself, and to the unit roof panel to prevent moisture intrusion into the unit or building.

**Figure 39: Suggested Flashing over Top Panels and Sides of Units**

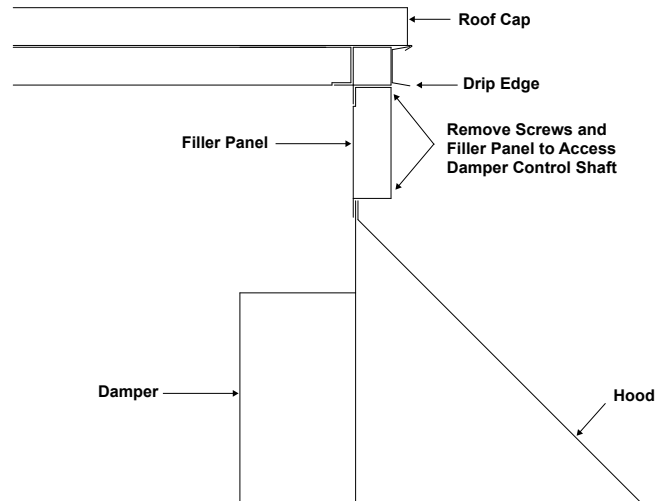


## Dampers and Hoods

Side dampers may be provided in the mixing box and economizer sections of units. When dampers are provided, access to the damper drive shaft is recommended internally through the upstream or downstream sections of the unit. If no internal access is available, a removable panel is located above the weather hood to provide access to the damper drive shaft.

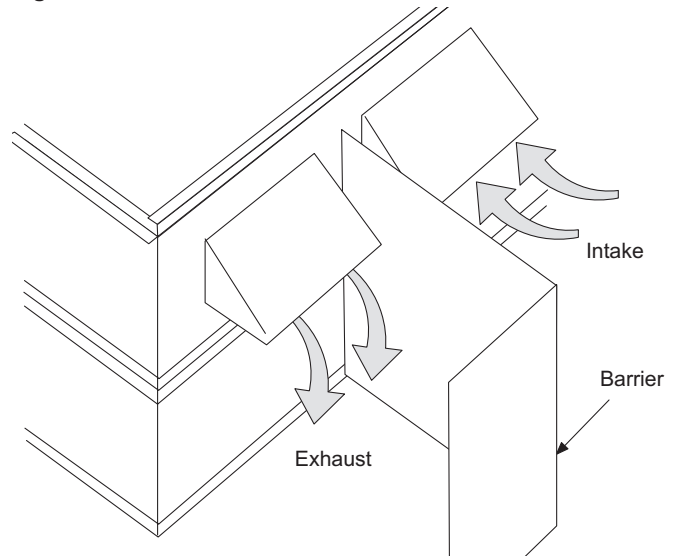
**NOTE:** The hood and damper must be removed to remove the panel. Other access may be available depending on the specific construction of the unit (Figure 40).

**Figure 40: Filler Panel Over the Weather Hood**



When units are ordered with exhaust hoods and intake hoods adjacent to each other, install a field-supplied barrier to prevent recirculation of exhaust air into the intake openings. (Figure 41).

**Figure 41: Field-Installed Barrier Between Hoods**



## Collapsible Hood Assembly

**NOTE:** A plastic bag containing screws, required for this assembly, will be provided by Daikin Applied.

1. Pull up on the collapsed front panel.
2. Slide the side panels out and align screw holes.
3. Secure the side and top panels with #10 screws.
4. If present, pull up on the internal louvers until screw holes are aligned.
5. Secure the internal louvers with #10 screws.

## Mounting Actuators



### CAUTION

Maximum damper rotation is 70°. Maximum shaft torque is 205 in-lbs. Greater rotation or torque can cause equipment damage.

The installing contractor is responsible for the mounting of all field-installed actuators. No provisions are made for the location of these actuators due to the number of options and arrangements available and the variety of specific applications. Typically, actuators are mounted inside the cabinet. Provide proper support for the actuator to avoid excessive stress in the cabinet, linkage, or damper shafts.

**EXCEPTION:** For the angled economizer, the fresh air and return air dampers must always be driven by separate actuators.

**NOTE:** Damper blades are at full flow when open to 70 degrees. Do not open blades further than 70 degrees.

Fresh air and return air dampers can be linked together and driven from the same actuator if the dampers are the same size. If the dampers are different sizes, they must be driven by separate actuators and controlled appropriately. Exhaust dampers are always driven by a separate actuator.

A typical rotary electric actuator can handle up to 40 sq.ft. of damper. For pneumatic actuators, allow 5 in-lb per square foot of damper area.

## Angled Economizer Actuator Access

Access to the fresh air and exhaust air damper drive shafts of the angled economizer is recommended internally through the upstream or downstream sections of the unit. If no internal access is available, a removable filler panel is located above the weather hood to provide access to the damper drive shaft.

**NOTE:** The hood and damper must be removed to remove the panel. (Figure 41) There are two options for gaining access to the return air damper drive shaft:

1. If the unit has a housed return fan or plenum exhaust fan, an access section should be located immediately downstream of the economizer section for access to the return air damper drive shaft.
2. If the unit has a plenum return fan or housed exhaust fan, access to the return air damper drive shaft can be obtained via the fan section's access door and the removable filler panel located above the return air damper.

## Face and Bypass Section Mounting

Internal and external face and bypass sections are mounted together using the instructions for horizontal components and do not require additional instruction. Skyline air handlers are provided with a bypass duct that is integral to the unit construction and requires no field assembly.

Face and bypass dampers may or may not be linked together. When dampers are placed before a single bank of coils, they always are linked together and require a single actuator. When dampers bypass a stacked or staggered coil, the dampers are not linked and require multiple actuators.

Face and bypass dampers have a torque requirement of 10 in-lbs per square foot of damper face area.

## Isolation Dampers for Multiple Fans

Optional isolation dampers can be provided on multiple fans to prevent backflow through a fan that is turned off for service. These isolation dampers are not intended to be used to control flow through the fan. The isolation damper for a fan that is going to be started must be positioned in the full open position before the fan is started. Do not start a fan with the damper located at the inlet with the damper fully or partially closed. This can cause airflow, vibration, and sound problems that can lead to failure.

Isolation dampers can be provided with actuators that are mounted in the airstream. Actuator sizing for the isolation dampers should be based on 9 in-lb per square foot of damper.

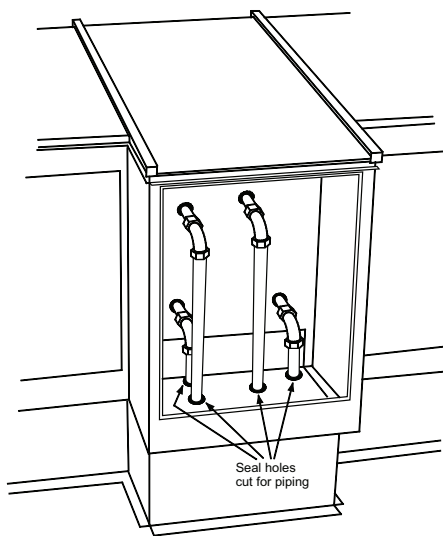
## Piping Vestibules

The Skyline air handler has two options for piping vestibules. The curb-ready base and base rail option units have a factory installed vestibule, whereas the unitized base option has a field installed vestibule. See the order for details.

For units that include a piping vestibule, cut the openings for routing the field piping as required in the field. Carefully seal passages cut through the panels to prevent air leakage. A single metal thickness pan is provided in the bottom of the curb-mounted vestibule. The pan can be removed if necessary. If holes are cut into the pan for a piping passage, seal the holes to prevent moisture leakage (Figure 42).

**NOTE:** For units with a curb-ready or unitized curb-ready base, the vestibule is closed to the coil section.

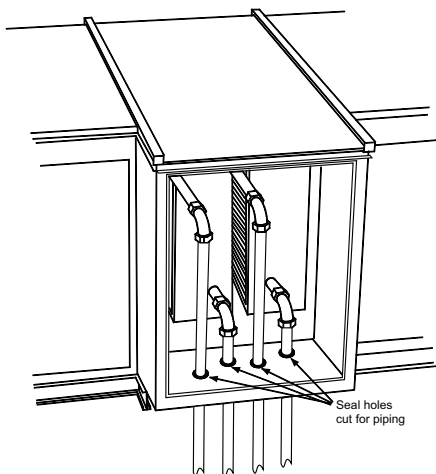
**Figure 42: Seal Holes for Piping—Curb Mounted Units**



**NOTE:** For units with standard base rails, the vestibule is open to the coil section. Seal all holes to prevent air leakage.

**NOTE:** On standard base rail units, the vestibule is allowed to be cantilevered and no bottom support is required.

**Figure 43: Seal Holes for Piping—Standard Base Rail Units**



## Field-Installed Vestibule

### ⚠ WARNING

Use all lifting points. Improper lifting can cause severe personal injury or property damage.

### ⚠ CAUTION

Lifting points may not be symmetrical to the center of gravity of the unit. Ballast or unequal cable lengths maybe required.

The unit can be shipped with an optional field installed vestibule. Vestibule will ship fully assembled on a separate shipping pallet. Lifting lugs are located at the top of the vestibule. Field installed vestibule is designed to mounted on a Skyline roof curb. See IM 770 for curb installation details.

### Field-Installed Vestibule Installation

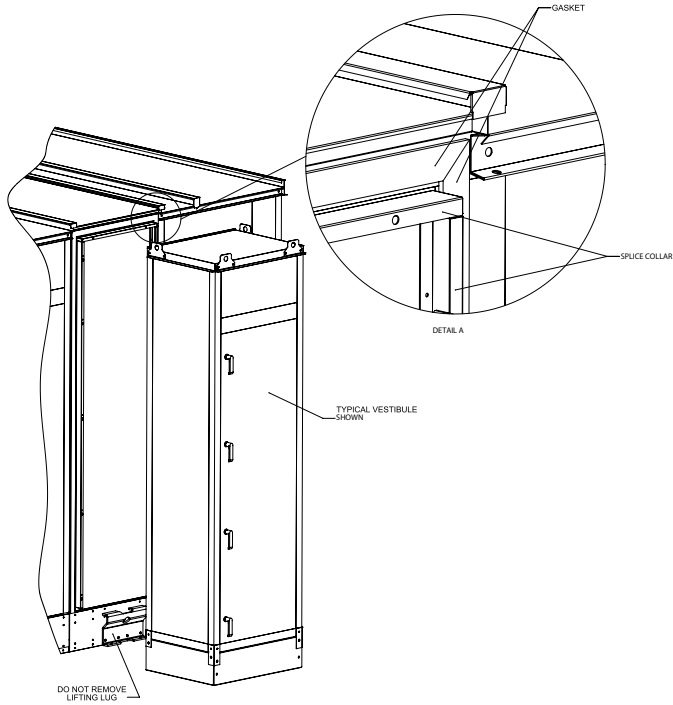
The vestibule comes completely assembled from the factory.

1. Inspect the gasket and splice collar to ensure they are secure and not damaged. Refer to Figure 45, Detail A.
2. Follow the instructions to attach rigging and lift the vestibule vertically. Remove the shipping pallet.
3. Apply a continuous bead of caulking to the vertical flange of the vestibule roof cap on the side that faces the unit (Figure 45).
4. With the unit in position, lift the vestibule onto the vestibule curb and align it as close as possible to its final position. Make sure not to damage the gasket on the side of the unit. Refer to Figure 45, Detail A.
5. Use the crane and rigging to relieve the weight of the vestibule, manually push and slide the vestibule next to the unit.
6. Access the inside of the vestibule by opening the door or removing the outer panel.
7. Use the supplied mounting screws to connect the vestibule to the unit, screwing through the flange of the vestibule and into the small binding holes of the splice collar. See Figure 47.
8. Use supplied angle bracket to connect the vestibule to the unit as shown in Figure 44.
9. Once the vestibule is secured to the unit, remove the rigging and apply additional caulking to both corner seams. See Figure 46.

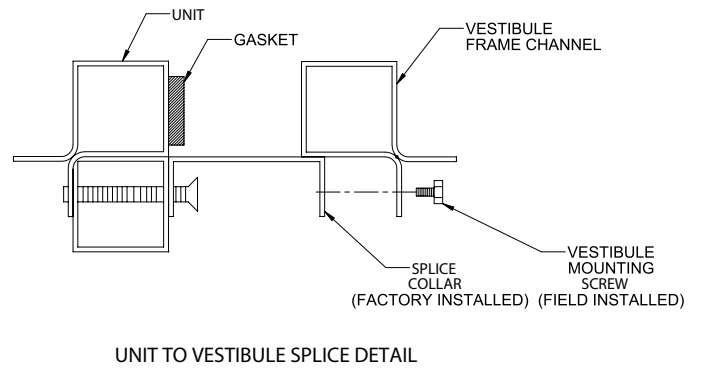
**Figure 44: Angle Bracket**



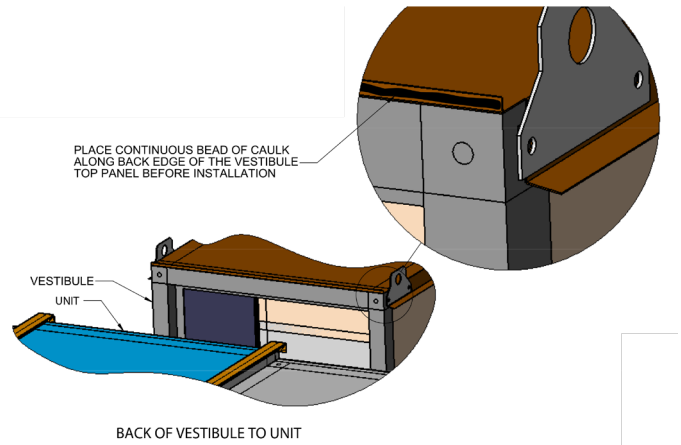
**Figure 45: Typical Vestibule**



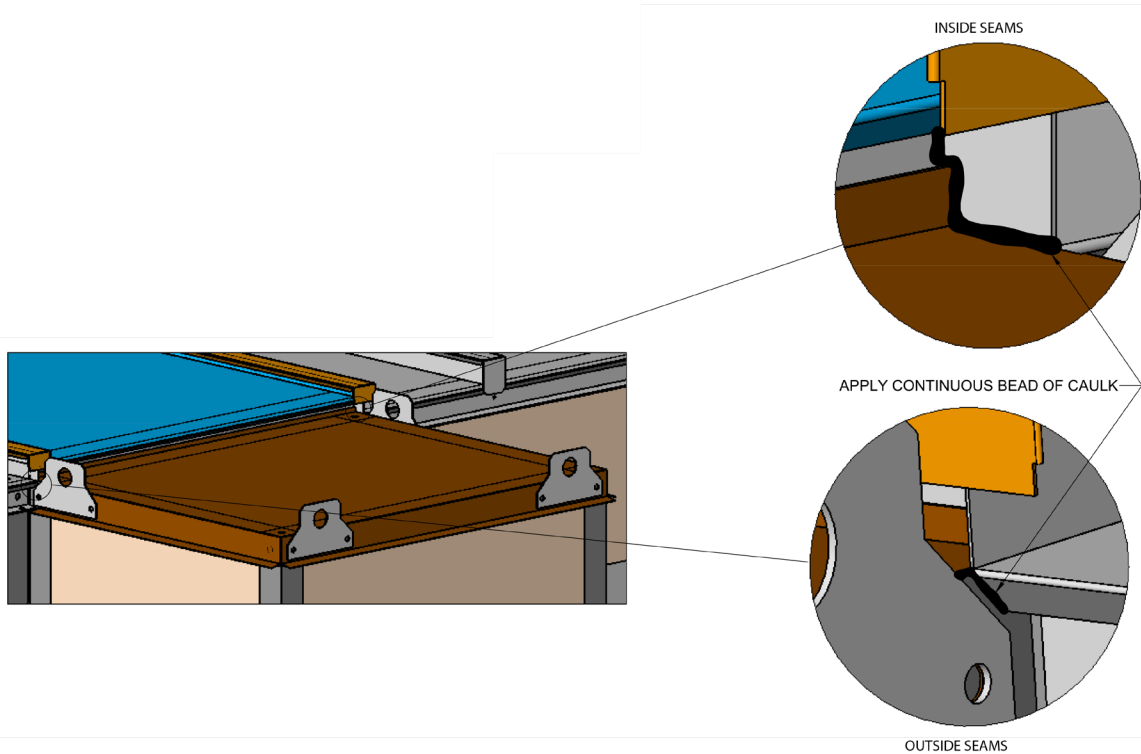
**Figure 47: Detail of Mounting Screws**



**Figure 48: Caulking the Vestibule Roof Cap**



**Figure 46: Additional Caulking**



## Piping and Coils

When designing and installing piping:

- Follow applicable piping design, sizing, and installation information in ASHRAE handbooks.
- Vision units paired with a condenser section as part of a split system should review the condenser installation manual for relevant pipe design guidelines.
- Observe all local codes and industry standards.
- Do not apply undue stress at the connection to coil headers; always use a backup pipe wrench.
- Support pipework independently of the coils.
- Maximum design pressure is labeled on the exterior of the unit.

## Field-Installed Coils

1. Prior to installing the filler panel and coil panel, apply even beads of caulk around the entire drain pan.
2. Smooth out any excess and allow it to fully cure.
3. Inspect the seal for any gaps or voids. Apply additional caulk as needed to ensure a complete seal.
4. Confirm that the drain pan is fully sealed before proceeding with panel installation.

## Water Cooling Coils

**NOTE:** Use glycol in water coils for outdoor air handlers. Power failures and other mechanical issues can expose coils to freezing temperatures.

- Water supply, water return, drain, and vent connections extend through the end panel of the coil section. All connections are labeled on the end panel.
- Water supply and water return connections are typically male NPT iron pipe.
- When installing couplings, do not apply undue stress to the connection extending through unit panel. Use a backup pipe wrench to avoid breaking the weld between coil connection and header.
- Follow recommendations of the control manufacturer regarding types, sizing, and installation of controls.

## Direct Expansion Coils

### *Non-A2L Refrigerant Type*

- When a field supplied thermostatic expansion valve is used, it is located outside the unit and connected directly to the distributor. Do not apply heat to the body of the expansion valve.
- The thermostatic expansion valve must be of the external equalizer tube type. Connect the 1/4" diameter external equalizer tube provided on the coil to connection on expansion valve.
- See EPA regulation for serviceable coil installation rules and guidelines. Equipment shipped after 01/01/2025 will be supplied with a label indicating that it is intended for servicing existing equipment only. This will be applicable to systems with a total capacity less than 65,000 BTUs.

### *R32 and R454B Refrigerant Type*

- Expansion valves are not provided by Daikin Applied. See the condenser unit manufacturer's unit literature for expansion valve type and size. Expansion valve to be located outside the unit and connected directly to the distributor. Do not apply heat to the body of the expansion valve.
- The coil distributor and suction connection extend through the end panel of the coil section.
- Check nozzle in distributor for proper tonnage. Use care when piping the system to see that all joints are tight and all lines are dry and free of foreign material. For typical refrigerant piping, see the condensing unit literature.
- See condensing unit literature for refrigerant charging instructions.
- Direct expansion coils shall only be connected and operated with condensing units rated for the same refrigerant.

## Modulating Hot Gas Reheat (MHGRH)

- MHGRH is offered as a combination coil, mounted downstream of a cooling DX coil in a single component section.
- MHGRH coil will be factory installed and will have input (discharge), output (liquid) connection points, and field piping connections.

## Minimum Room Area Calculation (A2L Refrigerants)

### WARNING

Never allow this unit to service room(s) in which the total room area does not meet the minimum room area requirement. This may lead to flammable or toxic conditions, causing equipment damage, serious personal injury, or death.

- Units installed with an A2L refrigerant must be evaluated for each circuit's total charge. Total refrigerant charge is calculated by adding the DX coil, field piping, and condenser charge together for a particular circuit.
- Using the circuit with the greater total charge (if applicable), the minimum allowable room area must be calculated and recorded on the unit safety label. See [Minimum Room Area on page 68](#) for guidance on the minimum allowable room area calculation.

**NOTE:** Use permanent marker that conforms to ASTM D-4236.

## Steam Coils

### Piping (see [Figure 52](#))

- Steam supply and steam return connections typically are male NPT iron pipe and are labeled on the end panel of coil section. Connections extend through the coil section end panel.
- When installing couplings, do not apply undue stress to the connection extending through unit panel. **Use a backup pipe wrench to avoid breaking the weld between coil connection and header.**
- Support piping independently of coils and provide adequate piping flexibility. Stresses resulting from expansion of closely coupled piping can cause serious damage.
- Do not reduce pipe size at the coil return connection. Carry return connection size through the dirt pocket, making the reduction at the branch leading to the trap.

## Coils

- Pitch all steam coils in units toward the return connection.
- Do not drip supply mains through the coil.
- Do not attempt to lift condensate when using modulating or ON/OFF control.
- Install vacuum breakers on all applications to prevent retaining condensate in the coil. Generally, connect the vacuum breaker between the coil inlet and the return main. The vacuum breaker should be open to the atmosphere and the trap design should allow venting of large quantities of air.

## Traps

**NOTE:** Do not place steam traps outdoors.

- Size traps in accordance with the manufacturers' recommendations. Make sure the required pressure differential is always available. Do not undersize.
- Use float and thermostatic or bucket traps for low pressure steam. On high pressure steam, use bucket traps. Use thermostatic traps only for air venting.
- Use bucket traps for ON/OFF control only.
- Locate traps at least 12 inches below the coil return connection.
- Multiple coil installation—individually trap each coil or group of coils.
- Coils in series—use separate traps for each coil, or a bank of coils.
- Coils in parallel—a single trap can be used, but an individual trap for each coil is preferred.
- Do not attempt to lift condensate when using modulating or ON/OFF control.
- With coils arranged for series airflow, use a separate control on each bank or coil in the direction of airflow.

## Valves

- Do not use modulating steam valves on high pressure systems.
- Properly size modulating valves. Do not undersize.
- Avoid freezing conditions (entering air temperatures below 35°F).
- Daikin Applied strongly recommends 5JA, 8JA, 5RA and 8RA coils.
- Supply 5 psi steam to coils at all times.
- Do not use modulating valves. Provide control by face and bypass dampers.
- Consider using two or three coils in series with two position steam control valves on the coil or coils that handle 35°F or colder air. Use a modulating valve on the downstream coil to provide the desired degree of control.
- Thoroughly mix fresh air and return air before it enters the coil. Also, to obtain true air mixture temperatures, properly locate temperature control elements.
- As additional protection against freeze-up, install the trap sufficiently below the coil to provide an adequate hydrostatic head to remove condensate during an interruption in the steam pressure. Estimate three feet for each 1 psi of trap differential required.
- On startup, admit steam to coil ten minutes before admitting outdoor air.
- Close fresh air dampers if steam supply pressure falls below the minimum specified.

## Pipe Chases

Follow these guidelines when routing field supplied internal piping through the bottom of a unit.

- Determine what style base and options were selected:
  - Is there a secondary drip pan integrated into the base of the unit? The base of a Skyline unit meant to sit on a roof curb has a secondary drip shield installed below every panel that drains potential moisture to the outside frame trough.
  - Was an uninsulated sheet metal pipe chase cover selected?
- Determine the number and location of holes required for piping as follows:
  - Check that adequate space is available inside the unit for pipe routing.
  - Hole(s) must be located fully within panels or sheet metal opening covers. Do not run pipes through 4" wide intermediate panels or on the very edge of the panel.
  - Do not place holes in a location that impedes access to key maintenance components such as filters and fan assemblies.
  - Do not place holes in a location where the pipe will block airflow or obstruct hinged access doors.
- Once a proper location is determined:
  - If no secondary drip pan is present:
    - a. Drill a small pilot hole completely through the bottom cabinet panel, then using a sharp hole saw or saber saw, cut the desired final hole size and smooth the edges of the cut.
  - If no pipe chase cover is present:
    - a. Drill a small pilot hole completely through the secondary drip pan, then using a sharp hole saw or saber saw, cut the desired final hole size and smooth the edges of the cut. Repeat for the bottom cabinet panel.
  - If a pipe chase cover is present:
    - a. Remove the pipe chase cover to expose the secondary drip pan integrated into the unit base.
    - b. Drill a small pilot hole completely through the secondary drip pan, then using a sharp hole saw or saber saw, cut the desired final hole size and smooth the edges of the cut. Repeat for the pipe chase cover itself.
    - c. It may be easier to wait and replace the pipe chase cover after the hole in the secondary drip pan is sealed.
  - After installation of the piping, seal the hole(s) in the bottom cabinet panel, secondary drip pan, or pipe chase cover.
    - a. Seal the holes to divert any moisture away from the opening and prevent moisture leakage through the holes.

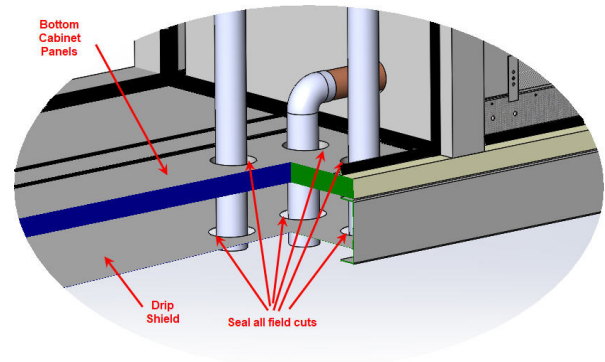
- b. Recommended sealing options include: flashing material, caulk, spray foam, cork tape, industrial or commercial grade silicone sealant, duct seal compound, or other similar sealing material.
- c. Pipe chase covers are not guaranteed to be airtight or watertight, but the pipe chase cover may be sealed in a similar manner to the other penetrations of the pipe chase cover if desired.

**NOTE:** The installer is responsible for ensuring the penetrations are fully sealed.

**NOTE:** Do not support piping off of the unit, coil connections, or secondary drip shield.

**NOTE:** It is extremely important to seal each hole or penetration securely so that they are airtight and watertight.

**Figure 49: Base and Drip Shield**



## Water Heating Coils

### ⚠ CAUTION

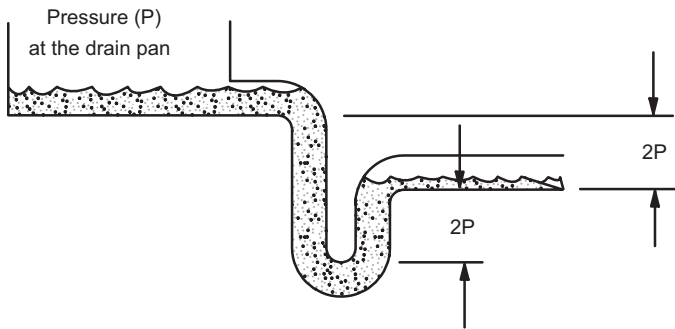
Improper installation, use, or maintenance of water heating coils can cause equipment damage. Read and follow instructions carefully.

- Water supply and water return connections extend through the end panel of the coil section. All connections are labeled on the end panel.
- Water supply and water return connections are male NPT iron pipe.
- When installing couplings, do not apply undue stress to the connection extending through unit panel. Use a backup pipe wrench to avoid breaking the weld between the coil connection and header.
- Follow recommendations of the control manufacturer regarding types, sizes, and installation of controls.
- Do not use hot water coils with entering air below 40°F.
- If fresh air and return air are to be heated by a hot water coil, carefully design the system to provide thorough mixing before air enters the coil.
- To prepare coils for winter operation, [See Winterizing Water Coils on page 64](#).

## Drain Pan Traps

Run drain lines and traps full size from the drain pan connection. Install drain pan trap to allow condensate to drain freely. On both blow-through and draw-through units, the trap depth and the distance between the trap outlet and the drain pan outlet must be twice the static pressure in the drain pan section under normal operation so the trap remains sealed (Figure 50).

**Figure 50: Trap Outlet and Drain Pan Outlet**



**NOTE:** The door panels on some applications have a close clearance over the drain pipes. Extend the drain fitting with a coupling if necessary for door clearance (Figure 51).

Use material that can withstand freezing temperatures for outdoor drain traps.

Drain traps that dry out can allow cold air to seep into the equipment.

**Figure 51: Extended Drain Fitting Door Clearance**

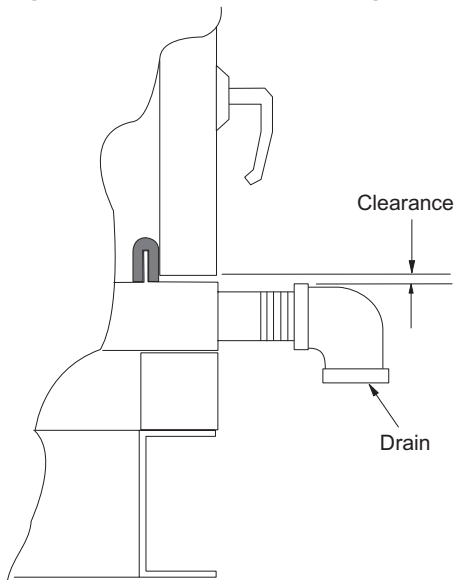
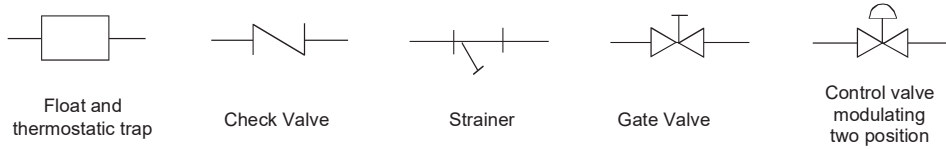
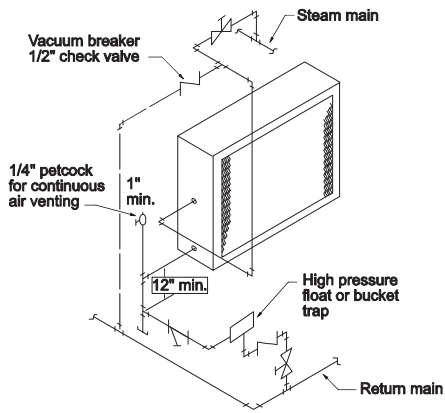


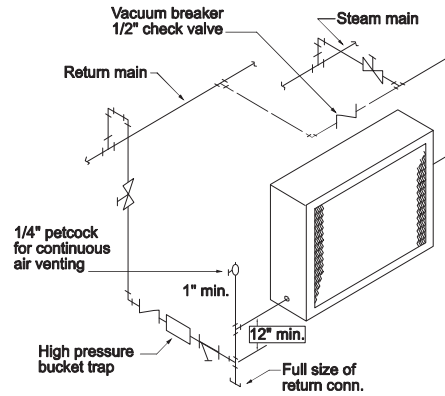
Figure 52: Piping Arrangements



**High Pressure (over 25 psi)**

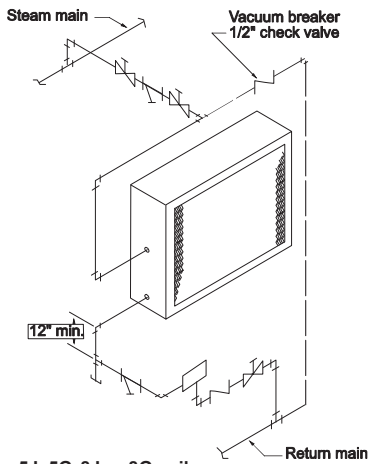


**5GA or 8GA coils.** Note that the addition of a vacuum breaker to permit the coil to drain during shutdown.

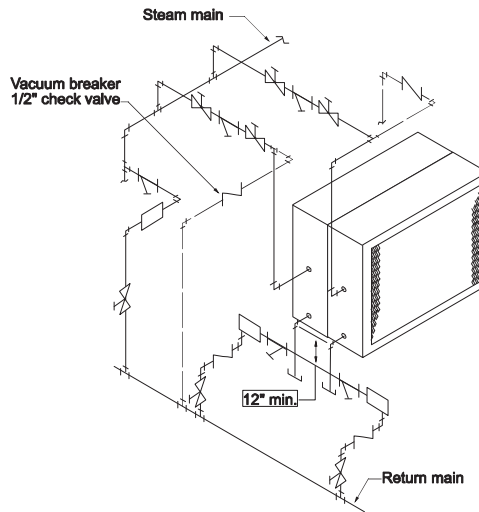


**5TA, 8TA, or 5HA coils.** Condensate is lifted to overhead return main

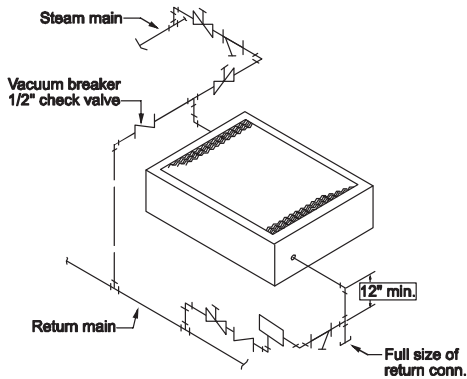
**Low Pressure (to 25 psi)**



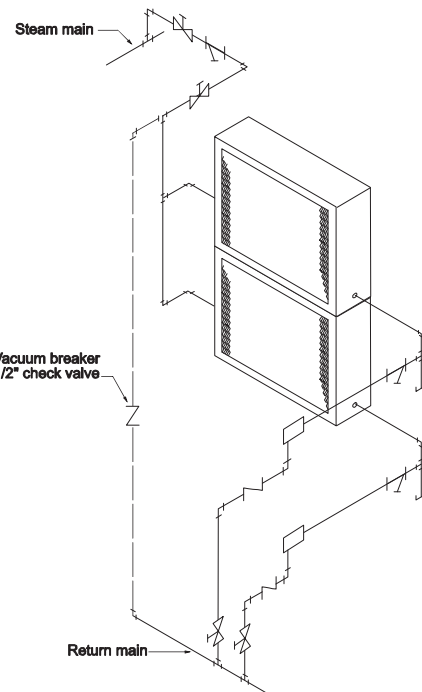
**5J, 5G, 8J or 8G coils.**



**5JA or 8JA coil.** Installed in series. Note that each coil must have a separate control valve and trap.



**5RA, 8RA, or 5SA coils.**



**5RA, 8RA, or 5SA coils.** Banked two high, individual trapping of each coil as shown is preferred.

# Integral Face and Bypass Coils

## Torque Requirements

### Non-Spring Return Actuator - Vertical Tubes

Table 1: Non-Spring Return Actuator Selections Information

Non-Spring Return Actuator Selections			
	Torque Rating	Max Face Area	Quantity Needed
LM SERIES	45 in-lb	11 sq. ft	1
NM SERIES	90 in-lb	22 sq. ft	1
AM SERIES	180 in-lb	45 sq. ft	1
GM SERIES	360 in-lb	90 sq. ft	1

Table 2: LM Series Torque Requirements

LM Series - Vertical Tubes - Face Area (sq. ft.)									
		Nominal Tube Length							
		2'-0"	2'-6"	3'-0"	3'-6"	4'-0"	4'-6"	5'-0"	5'-6"
Tube Face	8	3.7	4.7	5.6	6.5	7.4	8.4	9.3	10.2
	12	5.6	7.0	8.3	9.7	-	-	-	-
	16	7.4	9.2	-	-	-	-	-	-
	20	9.2	-	-	-	-	-	-	-

Table 3: NM Series Torque Requirements

NM Series - Vertical Tubes - Face Area (sq. ft.)														
		Nominal Tube Length												
		2'-0"	2'-6"	3'-0"	3'-6"	4'-0"	4'-6"	5'-0"	5'-6"	6'-0"	6'-6"	7'-0"	7'-6"	8'-0"
Tube Face	8	-	-	-	-	-	-	-	-	11.2	12.1	13.0	14.0	14.9
	12	-	-	-	-	11.1	12.5	13.9	15.3	16.7	18.1	19.5	20.9	
	16	-	-	11.1	12.9	14.8	16.6	18.5	20.3	-	-	-	-	-
	20	-	11.5	13.8	16.1	18.4	20.7	-	-	-	-	-	-	-
	24	11.1	13.8	16.6	19.4	-	-	-	-	-	-	-	-	-
	28	13.3	16.6	19.9	-	-	-	-	-	-	-	-	-	-
	32	14.7	18.4	-	-	-	-	-	-	-	-	-	-	-
	36	16.6	20.7	-	-	-	-	-	-	-	-	-	-	-
	40	18.4	-	-	-	-	-	-	-	-	-	-	-	-
	44	20.2	-	-	-	-	-	-	-	-	-	-	-	-

Table 4: AM Series Torque Requirements

AM Series - Vertical Tubes - Face Area (sq. ft.)														
		Nominal Tube Length												
		2'-0"	2'-6"	3'-0"	3'-6"	4'-0"	4'-6"	5'-0"	5'-6"	6'-0"	6'-6"	7'-0"	7'-6"	8'-0"
Tube Face	8	-	-	-	-	-	-	-	-	-	-	-	-	-
	12	-	-	-	-	-	-	-	-	-	-	-	-	22.2
	16	-	-	-	-	-	-	-	-	22.1	24.0	25.8	27.7	29.5
	20	-	-	-	-	-	-	23.1	25.4	27.7	30.0	32.3	34.6	36.9
	24	-	-	-	-	22.1	24.9	27.7	30.4	33.2	35.9	38.7	41.5	44.2
	28	-	-	-	23.2	26.6	29.9	33.2	36.5	39.8	43.2	-	-	-
	32	-	-	22.1	25.8	29.4	33.1	36.8	40.5	44.2	-	-	-	-
	36	-	-	24.8	29.0	33.1	37.3	41.4	-	-	-	-	-	-
	40	-	23.0	27.6	32.2	36.8	41.4	-	-	-	-	-	-	-
	44	-	25.3	30.4	35.4	40.5	-	-	-	-	-	-	-	-
	48	22.1	27.6	33.1	38.6	44.1	-	-	-	-	-	-	-	-

**Table 5: GM Series Torque Requirements**

		GM Series - Vertical Tubes - Face Area (sq. ft.)													
		Nominal Tube Length													
		2'- 0"	2'- 6"	3'- 0"	3'- 6"	4'- 0"	4'- 6"	5'- 0"	5'- 6"	6'- 0"	6'- 6"	7'- 0"	7'- 6"	8'- 0"	
Tube Face	8	-	-	-	-	-	-	-	-	-	-	-	-	-	
	12	-	-	-	-	-	-	-	-	-	-	-	-	-	
	16	-	-	-	-	-	-	-	-	-	-	-	-	-	
	20	-	-	-	-	-	-	-	-	-	-	-	-	-	
	24	-	-	-	-	-	-	-	-	-	-	-	-	-	
	28	-	-	-	-	-	-	-	-	-	-	46.5	49.8	53.1	
	32	-	-	-	-	-	-	-	-	-	47.8	51.5	55.2	58.9	
	36	-	-	-	-	-	-	-	45.5	49.7	53.8	58.0	62.1	66.2	
	40	-	-	-	-	-	-	46.0	50.5	55.1	59.7	64.3	68.9	73.5	
	44	-	-	-	-	-	45.5	50.6	55.7	60.7	65.8	70.8	75.9	81.0	
48	-	-	-	-	-	49.6	55.2	60.7	66.2	71.7	77.2	82.7	88.2		

**Spring Return Actuator - Vertical Tubes****Table 6: Spring Return Actuator Selections Information**

Spring Return Actuator Selections - Vertical			
	Torque Rating	Max Face Area	Quantity Needed
NF SERIES	60 in-lb	15 sq. ft.	1
AF SERIES	133 in-lb	33 sq. ft.	1
AF SERIES	266 in-lb	66 sq. ft.	2
FACE AREA TOO LARGE - MUST USE NON-SPRING RETURN ACTUATOR			

**Table 7: NF Series Torque Requirements**

		NF Series - Vertical Tubes - Face Area (sq. ft.)													
		Nominal Tube Length													
		2'- 0"	2'- 6"	3'- 0"	3'- 6"	4'- 0"	4'- 6"	5'- 0"	5'- 6"	6'- 0"	6'- 6"	7'- 0"	7'- 6"	8'- 0"	
Tube Face	8	3.7	4.7	5.6	6.5	7.4	8.4	9.3	10.2	11.2	12.1	13.0	14.0	14.9	
	12	5.6	7.0	8.3	9.7	11.1	12.5	13.9	-	-	-	-	-	-	
	16	7.4	9.2	11.1	12.9	14.8	-	-	-	-	-	-	-	-	
	20	9.2	11.5	13.8	-	-	-	-	-	-	-	-	-	-	
	24	11.1	13.8	-	-	-	-	-	-	-	-	-	-	-	
	28	13.3	-	-	-	-	-	-	-	-	-	-	-	-	
	32	14.7	-	-	-	-	-	-	-	-	-	-	-	-	
	36	-	-	-	-	-	-	-	-	-	-	-	-	-	
	40	-	-	-	-	-	-	-	-	-	-	-	-	-	
	44	-	-	-	-	-	-	-	-	-	-	-	-	-	
48	-	-	-	-	-	-	-	-	-	-	-	-	-		

**Table 8: AF Series (133 in-lb) Torque Requirements**

		AF Series (133 in-lb) - Vertical Tubes - Face Area (sq. ft.)													
		Nominal Tube Length													
		2'- 0"	2'- 6"	3'- 0"	3'- 6"	4'- 0"	4'- 6"	5'- 0"	5'- 6"	6'- 0"	6'- 6"	7'- 0"	7'- 6"	8'- 0"	
Tube Face	8	-	-	-	-	-	-	-	-	-	-	-	-	-	
	12	-	-	-	-	-	-	-	15.3	16.7	18.1	19.5	20.9	22.2	
	16	-	-	-	-	-	16.6	18.5	20.3	22.1	24.0	25.8	27.7	29.5	
	20	-	-	-	16.1	18.4	20.7	23.1	25.4	27.7	30.0	32.3	-	-	
	24	-	-	16.6	19.4	22.1	24.9	27.7	30.4	-	-	-	-	-	
	28	-	16.6	19.9	23.2	26.6	29.9	-	-	-	-	-	-	-	
	32	-	18.4	22.1	25.8	29.4	-	-	-	-	-	-	-	-	
	36	16.6	20.7	24.8	29.0	-	-	-	-	-	-	-	-	-	
	40	18.4	23.0	27.6	32.2	-	-	-	-	-	-	-	-	-	
	44	20.2	25.3	30.4	-	-	-	-	-	-	-	-	-	-	
48	22.1	27.6	-	-	-	-	-	-	-	-	-	-	-		

**Table 9: AF Series (266 in-lb) Torque Requirements**

		AF Series (266 in-lb) - Vertical Tubes - Face Area (sq. ft.)													
		Nominal Tube Length													
		2'- 0"	2'- 6"	3'- 0"	3'- 6"	4'- 0"	4'- 6"	5'- 0"	5'- 6"	6'- 0"	6'- 6"	7'- 0"	7'- 6"	8'- 0"	
Tube Face	8	-	-	-	-	-	-	-	-	-	-	-	-	-	
	12	-	-	-	-	-	-	-	-	-	-	-	-	-	
	16	-	-	-	-	-	-	-	-	-	-	-	-	-	
	20	-	-	-	-	-	-	-	-	-	-	-	34.6	36.9	
	24	-	-	-	-	-	-	-	-	33.2	35.9	38.7	41.5	44.2	
	28	-	-	-	-	-	-	33.2	36.5	39.8	43.2	46.5	49.8	53.1	
	32	-	-	-	-	-	33.1	36.8	40.5	44.2	47.8	51.5	55.2	58.9	
	36	-	-	-	-	33.1	37.3	41.4	45.5	49.7	53.8	58.0	62.1	<b>66.2</b>	
	40	-	-	-	-	36.8	41.4	46.0	50.5	55.1	59.7	64.3	<b>68.9</b>	<b>73.5</b>	
	44	-	-	-	35.4	40.5	45.5	50.6	55.7	60.7	65.8	<b>70.8</b>	<b>75.9</b>	<b>81.0</b>	
48	-	-	33.1	38.6	44.1	49.6	55.2	60.7	<b>66.2</b>	<b>71.7</b>	<b>77.2</b>	<b>82.7</b>	<b>88.2</b>		

**NOTE:** Figures in bold with grey background indicate face area being too large. A non-spring return actuator must be used.

**Non-Spring Return Actuator - Horizontal Tube**

**Table 10: Non-Spring Return Actuator Selections Information (Horizontal)**

Non-Spring Return Actuator Selections (Horizontal)			
	Torque Rating	Max Face Area	Quantity Needed
<b>LM SERIES</b>	45 in-lb	11 sq. ft	1
<b>NM SERIES</b>	90 in-lb	22 sq. ft	1
<b>AM SERIES</b>	180 in-lb	45 sq. ft	1

**Table 11: LM Series Torque Requirements**

		LM Series - Horizontal Tube - Face Area (sq. ft.)									
		Nominal Tube Length									
		1'- 0"	1'- 6"	2'- 0"	2'- 6"	3'- 0"	3'- 6"	4'- 0"	4'- 6"	5'- 0"	
Tube Face	9	1.66	2.48	3.31	4.14	4.97	5.80	6.63	7.45	8.28	
	12	2.30	3.45	4.59	5.74	6.89	8.04	9.19	10.34	-	
	15	2.94	4.41	5.88	7.34	8.81	10.28	-	-	-	
	18	3.58	5.37	7.16	8.95	10.73	-	-	-	-	
	21	4.22	6.33	8.44	10.55	-	-	-	-	-	
	24	4.86	7.29	9.72	-	-	-	-	-	-	

**Table 12: NM and AM Series Torque Requirements**

NM and AM Series - Horizontal Tube - Face Area (sq. ft.)										
		Nominal Tube Length								
		1'- 0"	1'- 6"	2'- 0"	2'- 6"	3'- 0"	3'- 6"	4'- 0"	4'- 6"	5'- 0"
Tube Face	9	-	-	-	-	-	-	-	-	-
	12	-	-	-	-	-	-	-	-	11.48
	15	-	-	-	-	-	-	11.75	13.22	14.69
	18	-	-	-	-	-	12.52	14.31	16.10	17.89
	21	-	-	-	-	12.66	14.77	16.88	18.98	21.09
	24	-	-	-	12.15	14.58	17.01	19.44	21.87	<b>24.30</b>

NOTE: Figure in bold with grey background indicates AM series torque value.

### Spring Return Actuator - Horizontal Tube

**Table 13: Spring Return Actuator Selections Information (Horizontal)**

Spring Return Actuator Selections (Horizontal)			
	Torque Rating	Max Face Area	Quantity Needed
NF SERIES	60 in-lb	15 sq. ft.	1
AF SERIES	133 in-lb	33 sq. ft.	1

**Table 14: NF Series Torque Requirements**

NF Series - Horizontal Tube - Face Area (sq. ft.)										
		Nominal Tube Length								
		1'- 0"	1'- 6"	2'- 0"	2'- 6"	3'- 0"	3'- 6"	4'- 0"	4'- 6"	5'- 0"
Tube Face	9	1.66	2.48	3.31	4.14	4.97	5.80	6.63	7.45	8.28
	12	2.30	3.45	4.59	5.74	6.89	8.04	9.19	10.34	11.48
	15	2.94	4.41	5.88	7.34	8.81	10.28	11.75	13.22	14.69
	18	3.58	5.37	7.16	8.95	10.73	12.52	14.31	-	-
	21	4.22	6.33	8.44	10.55	12.66	14.77	-	-	-
	24	4.86	7.29	9.72	12.15	14.58	-	-	-	-

**Table 15: AF Series Torque Requirements**

AF Series - Horizontal Tube - Face Area (sq. ft.)										
		Nominal Tube Length								
		1'- 0"	1'- 6"	2'- 0"	2'- 6"	3'- 0"	3'- 6"	4'- 0"	4'- 6"	5'- 0"
Tube Face	9	-	-	-	-	-	-	-	-	-
	12	-	-	-	-	-	-	-	-	-
	15	-	-	-	-	-	-	-	-	-
	18	-	-	-	-	-	-	-	16.10	17.89
	21	-	-	-	-	-	-	16.88	18.98	21.09
	24	-	-	-	-	-	17.01	19.44	21.87	24.30

## Internal Isolation Assembly Adjustment

On units with internally isolated fan and motor assemblies, the assemblies are secured for shipment with a tie-down at each point of isolation.

### Before Operating the Unit:

Remove the shipping brackets and tie-down bolts (see [Figure 5450](#), [Figure 551](#) and [Figure 562](#)) and discard. The shipping brackets located on the opposite drive side of the unit are difficult to access from the drive side of the unit. Either remove them before the unit is assembled or remove the panel on the opposite drive side to gain access.

The spring isolators under the four corners of the fan and motor assembly are factory adjusted while the fan was not running. See [Table 16](#) through [Table 20](#) below. With the unit operating at normal cfm and static pressure, all the isolators should be at the same height opening. If adjustments are required, loosen the 1/2" cap screw on top of the isolator and turn the adjusting bolt to lower or raise the fan and motor base. Retighten the cap screw when adjustments are completed.

**Table 16: Motor Beside Fan Spring Mount Adjustments**

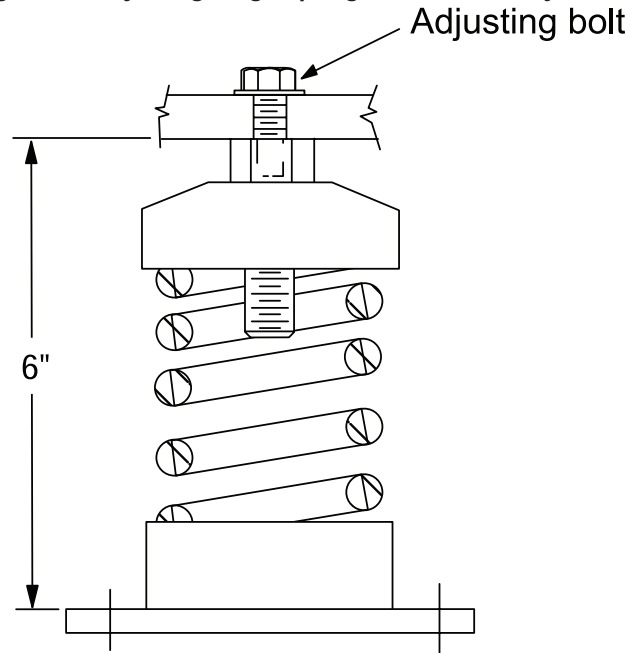
Spring Mount Adjustment at Rest			
Isolator position	Top or Bottom Horz. H	Downblast H	Upblast H
Unit Sizes 003 – 035			
1	3.75	3.75	4.25
2	4.25	3.75	4.25
3	4.25	3.75	4.25
4	3.75	3.75	4.25
Unit Sizes 040 – 090			
1	6.00	6.75	6.75
2	6.50	6.75	6.75
3	6.50	6.75	6.75
4	6.00	6.75	6.75

**Table 17: Motor Behind Fan Spring Mount Adjustments**

Spring Mount Adjustment at Rest			
Isolator Position	Top Or Bottom Horz. H	Downblast H	Upblast H
Unit Sizes 003 – 035			
1	6.75	6.75	6.75
2	6.75	6.75	6.75
3	6.75	6.75	6.75
4	6.75	6.75	6.75
Unit Sizes 040 – 090			
1	6.75	6.75	6.75
2	6.75	6.75	6.75
3	6.75	6.75	6.75
4	6.75	6.75	6.75

For models 040 through 090 with housed fans, the isolators should be at equal height during fan operation (6"). Center the fan outlet in the outlet panel opening. If adjustment is required, loosen the cap screw on top of the isolator assembly. Turn the adjustment nut below the fan frame to lower or raise the fan motor and frame assembly. Retighten the cap screw on top of the isolator assembly.

**Figure 53: Adjusting Large Spring Mount Assembly**



**Table 18: Class II Belt-Drive Plenum Fan Spring Height**

Fan Size	Isolator Type	Operating Height (in.)
13–16	Standard 2"	Deflection 4.5
18–36	Standard 2"	Deflection 4.0
13–36	Seismic	4.0
40–60	All	6.75

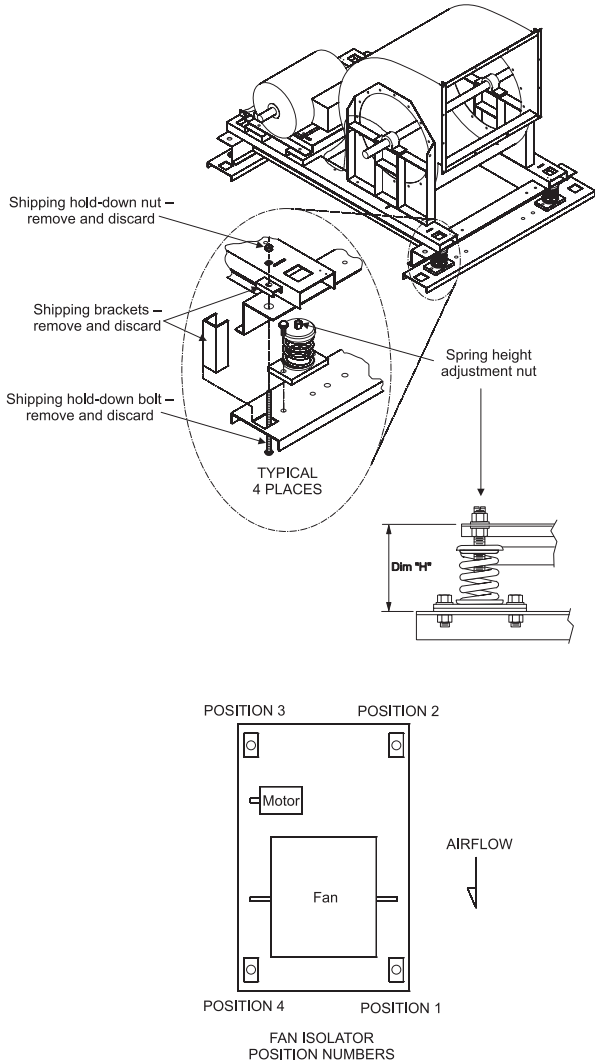
**Table 19: Class III Plenum Fan Spring Height**

Cabinet Width	Isolator Type	Operating Height (in.)
Width < 108"	All	4.0
Width > or = 108"	All	6.75

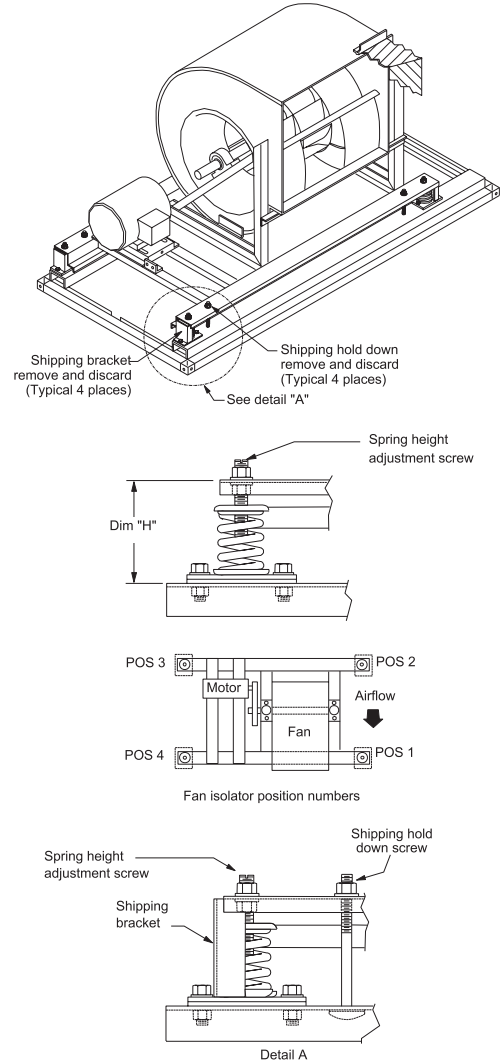
**Table 20: Class II Direct-Drive Plenum Fan Spring Height**

Fan Size	Isolator Type	Operating Height (in.)
11–36	All	4.0
40–44	All	6.75

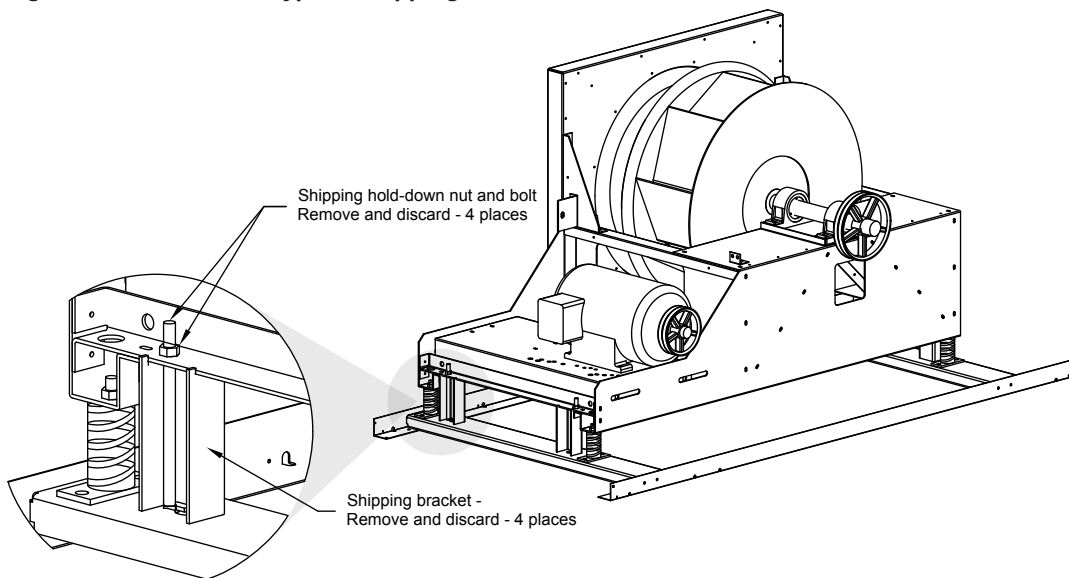
**Figure 54: Removing "Motor Behind" Shipping Brackets**



**Figure 55: Removing "Motor Beside" Shipping Brackets**



**Figure 56: Plenum Fan Typical Shipping Brackets**



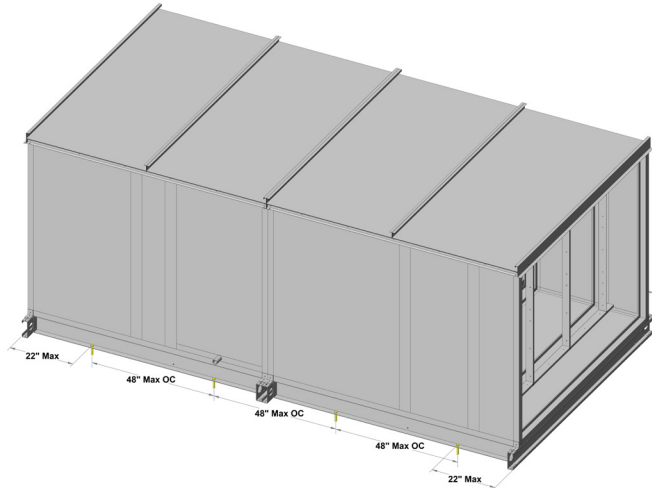
## HCAI Seismic Anchoring/Mounting

For seismic stability of the unit, additional anchoring and mounting procedures are required. The anchoring options and corresponding spectral response acceleration are given in [Table 21](#). Holes in the Vision/Skyline base frame are to be field drilled. Any mounting hardware is to be field supplied.

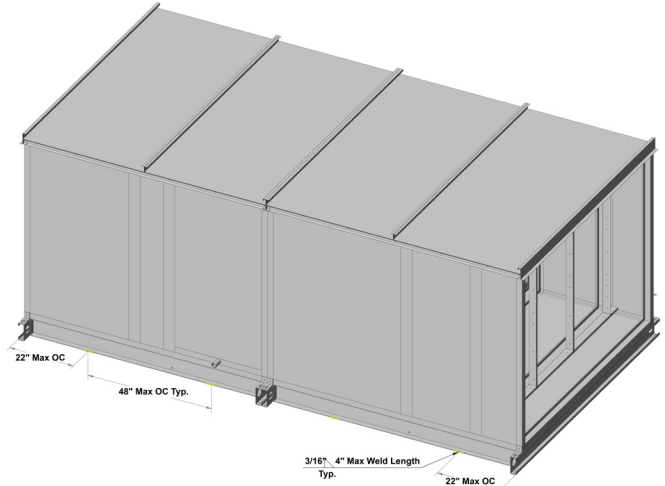
**Table 21: HCAI Mounting**

Attachment Method	SDS	Attachment System (by Others)	
		Spacing	System
Bolted attachment to steel ( <a href="#">Figure 57</a> )	1.93	48	5/8" DIA SAE Grade 5
Welded attachment to steel ( <a href="#">Figure 58</a> )	1.84	48	3/16" Weld Leg and 4" welded length
Bolted attachment to Concrete ( <a href="#">Figure 59</a> )	1.68	24	Hilti HDA-P M16 x 190/40 with 7.48" embedment

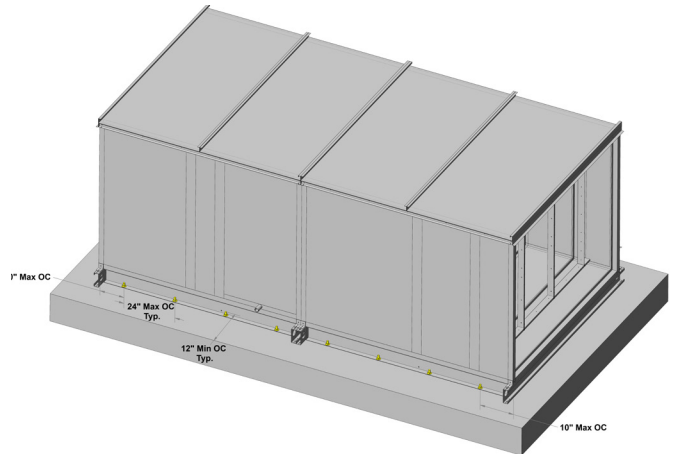
**Figure 57: Unit with Base Frame Mounted on Steel**



**Figure 58: Unit with Base Frame Welded**



**Figure 59: Unit with Base Frame Mounted on Concrete**



# Electrical Installation

## **⚠ DANGER**

**Capacitor hazardous voltage!** Failure to disconnect power and discharge capacitors before servicing will result in serious injury or death. Disconnect all electric power (including remote disconnects) before servicing. Perform lockout/tag out procedures to ensure that power can not be energized. For variable frequency drives, or other energy storing components that have been furnished and mounted by either Daikin Applied, or by others, refer to the specific manufacturer's literature for allowable waiting periods for discharge of capacitors. Verify capacitors have been discharged using an appropriate voltmeter.

## **⚠ DANGER**

- This equipment is not suitable for use in high impedance grounding or neutral systems.
- Connect only to low impedance, solidly grounded electrical supply systems.

Failure to follow these instructions will result in death or serious injury.

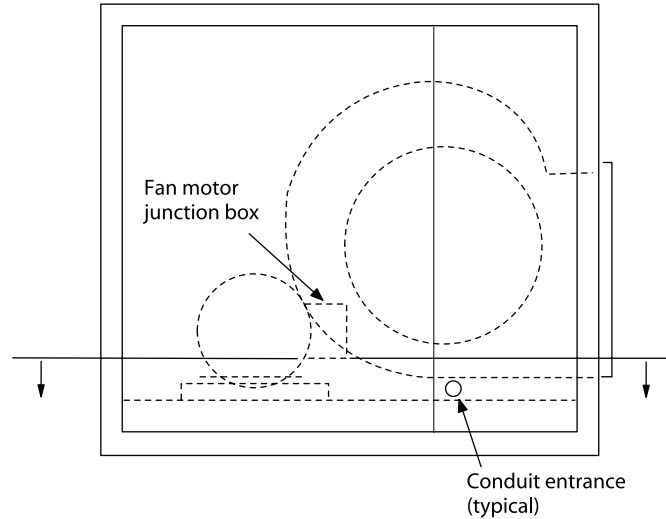
## **⚠ CAUTION**

**Use copper conductor only.** Failure to use copper conductors can result in equipment damage.

## **⚠ CAUTION**

The base section of each cabinet has a drip pan installed below every panel that drains to the outside frame trough. Any holes cut through the bottom of the unit must also penetrate the drip pan. If holes are cut in the drip pan, seal them to prevent moisture leakage.

**Figure 60: Electrical Conduit Location**



- Electrical wiring diagrams are provided with equipment.
- Electrical service to each fan must correspond to the rated voltage on the motor or electrical panel nameplate and conform to the National Electric Code and local restrictions.
- Connect each fan section metal frame to the building electrical ground.
- A door electrical interlock is not provided as standard.
- Thermal motor protection is external to the unit. Locate electrical conduit entrances for units above the bottom of the unit, high enough to clear components inside, but below the bottom of the fan motor junction box (Figure 60).
- When the unit is provided with an external junction box and variable frequency drive (VFD), the VFD itself will be mounted on the drive side fan panel inside the fan cabinet. The external junction box will provide loose wire connection to the VFD and to the motor. An external mounted keypad/display control box will be provided and connected to the VFD for manual adjustment of the VFD.
- When not being serviced, close and secure electrical panel doors to prevent accidental contact with live parts and prevent ingress of moisture and airborne contaminants.
- For instances where multiple motors are being driven by a single VFD, be sure to set up the VFD and size the wiring according to the power requirements of all motors that are being driven by that VFD.
- Control panel includes the type and rating of fuses and circuit breakers.
- Electrical enclosures contain information regarding purpose, voltage, current, and construction safety class.

- Control wiring—access to the VFD is through the fan cabinet access door for single fans. Provide shielded cable only as described in the VFD manual provided with the unit. Route wire through panel so that it not interfere with any other components or in the way of any access doors. Do not drill through drip or drain pans. Refer to the VFD installation manual provided with the unit for detailed control wiring instructions.
- For multiple fans in parallel, the VFD(s) are mounted inside of the electrical enclosure, which is mounted on the exterior of the fan section. When multiple fan sections are provided with multiple VFDs, they must be set up so that the fans always start simultaneously and are set to ramp up and down together. Do not attempt to run fans in parallel at different speeds as this can result in uneven airflow that can cause performance, sound, and vibration problems that can lead to failure. Provided that the fan is capable of running fast enough, the motor is sized appropriately, and the VFD can be sped up within its rated continuous output, VFDs may be operated up to a maximum recommended frequency of 90 Hertz for 1800 RPM and slower motors. Motors that are 3600 RPM may be operated up to a maximum speed of 4000 RPM or 66.7 Hertz provided the fan is rated that high. Operation above 4000 RPM can damage motor bearings and is not recommended.

## Wiring Penetrations

- Seal any panel penetrations for wiring or conduit per the panel cutting procedure instructions within this document.
- Seal any other wiring or conduit penetrations in accordance with NEC, relevant codes, and in order to maintain the enclosure rating, only use fittings that are approved to keep the particular rating of the individual enclosure being penetrated per relevant code or standard tables. Seal wireway openings tight enough to prevent air movement between sections and control enclosures.

## Electric and Gas Heat

### Electric Heat

Skyline rooftop units are available with unlimited step heat output. Skyline rooftop units with electric heat are designed for outdoor non-residential installations only. The electric heat design consists of a open coil heating elements, Step or SCR Vernier control or full SCR control, and all operational safeties. The safety switches include high-limit temperature switches and an airflow proving switch.

The high limit switch is an automatic reset switch. It opens the control circuit and shuts the heater down when the temperature reaches the high limit switch closes again allows the heater to run when the temperature gets below dead band. There is a second level of protection with an auxiliary high limit switch. This switch opens up and shuts the heater down when the temperature exceeds the set point. This switch requires a manual reset.

### Gas Furnace Heat

For installation and maintenance information related to gas furnace heat, refer to IM 1300.

### A2L Refrigerant Requirements

Daikin Applied units equipped with an A2L refrigerant (Optional DX Coil Component), requires means for mitigation in the unlikely event of a refrigerant leak. Units will therefore come equipped with an R32 or R454B Refrigerant Leak Detection System (RDS) and mitigation control relay with normally open contacts for mitigation activation. [See A2L Refrigerant Guidelines \(If Applicable\) on page 67](#) and the leak mitigation control board manual for more details.

For applications where an electric or gas heater is used in conjunction with a DX coil, the mitigation process requires the heat source to be de-energized using the RDS. The follow installation requirements apply:

- Daikin Applied Air Handler is equipped with an A2L refrigerant has a factory installed RDS. Sensor is located in the drain pan and wired to the mitigation control panel.
- Units in a modulating hot gas reheat (MHGRH) configuration will have two sensors; one downstream of the DX coil and one downstream of the MHGRH coil.
- The factory installed RDS in the Daikin Applied equipment may not be field modified.
- The RDS relay outputs (dry contacts) are field wired to the electric or gas heater control panel to de-energize the heater element when a refrigerant leak is detected. See DX coil mitigation control panel and electric heater control panel for schematics.

Figure 61: RDS Connection Point - Electric Heat Example

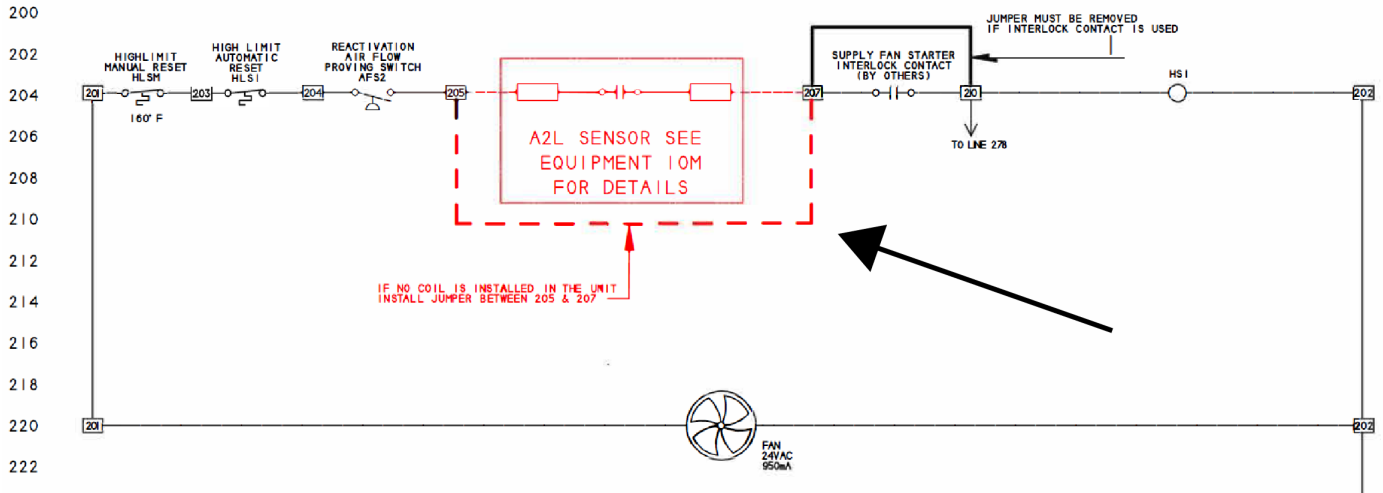
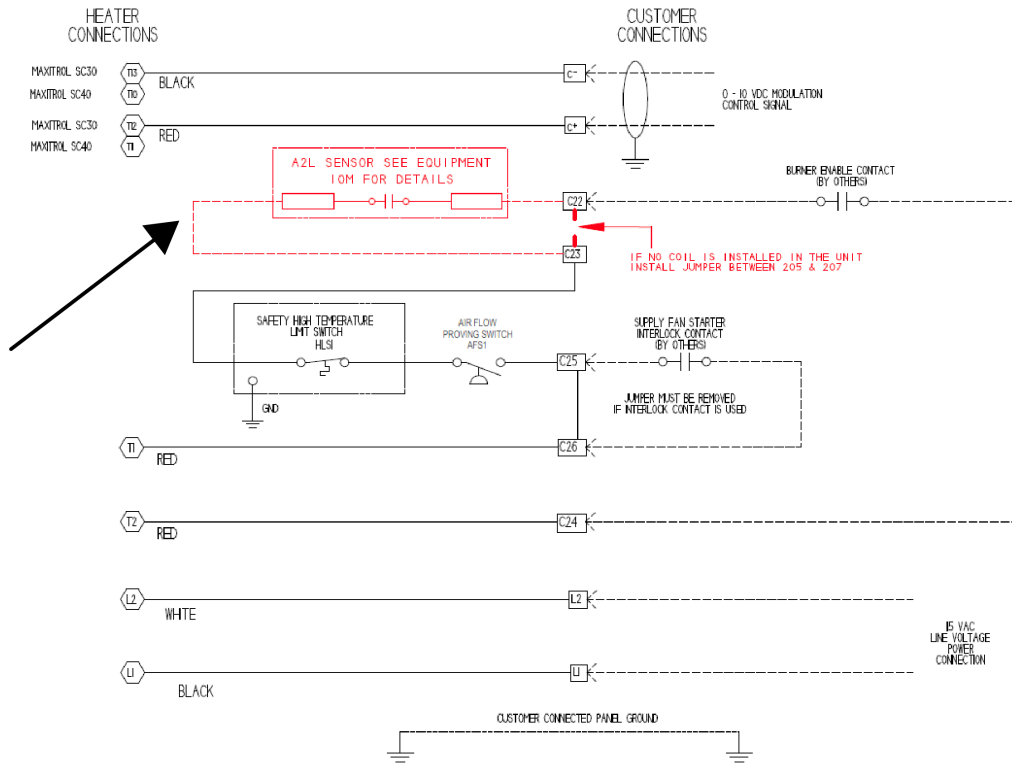


Figure 62: RDS Connection Point - Gas Heat Example



# Operation Guidelines

## Startup Checks

### WARNING

Rotating fan. Can cause severe injury or death. Before servicing fans, lock out and tag out power.

### WARNING

Fire/electric shock hazard. Can cause property damage, personal injury or death. Wire fan power supply and ground motor frame in accordance with local electric codes.

### WARNING

Fan motor requires overload protection. Failure to provide motor overload protection can result in fire, property damage, electric shock, personal injury, or death. Connect motor to an overload protective device rated in compliance with local electric codes.

### CAUTION

Do not overheat fan motor. High air temperatures in the fan section can cause the fan motor to burnout. On draw-through air handlers or air handlers with the fan section down the air stream from the heating section, the discharge air temperature of the heating section must not exceed 104°F (40°C).

### WARNING

Maximum operating altitude should not exceed 15,000 feet.

When performing startup and service, always take thorough safety precautions. Only trained, experienced personnel should perform these functions.

## Before Starting the Unit

### CAUTION

Equipment damage due to loose fasteners represents improper start-up and equipment abuse. It is not covered by the warranty.

Before entering fan section, make sure that fan electrical power source is disconnected and locked in the OFF position.

1. Check that the unit is completely and properly installed with ductwork connected.
2. Check that construction debris is removed/filters are clean.
3. Check that all electrical work is complete and properly terminated.
4. Check that all electrical connections are tight and that the proper voltage is connected. Phase imbalance must not exceed 2%.
5. Check that ball bearings on the fan shaft and motor are prelubricated and do not need grease before startup.
6. Check tightness of setscrews in bearings and fan wheel(s). If retightening is needed, position the fan wheel(s) per [Table 22](#) through [Table 25](#); [Table 26](#) through [Table 27](#). Torque set screws per [Table 28](#) and [Table 29](#).
7. Check alignment of fan and motor sheaves and belt tension. Adjust if necessary. Check tightness of sheave setscrews and/or capscrews. See [Table 28](#).
8. Leak test the thermal system to verify that connections are tight.
9. Check that the condensate drain is trapped.
10. Rotate the shaft by hand to be sure it is free.
11. If multiple fans are supplied with a block off plate and it is installed on one of the fans, make sure to only start the fans without the block off plate. Do not start any fan that has the block off plate installed on it.
12. If multiple fans are supplied with isolation dampers, make sure the isolation dampers are fully open before starting the fans.
13. If applicable, verify installation requirements have been followed for A2L refrigerants. See [page 67](#) for guidance.

## VFD Setup

Fans ordered with VFDs that were factory installed are setup and tested prior to shipment. Prior to starting the fan(s), double check the VFD settings according to the recommendations in the VFD manual.

Once the correct VFD settings are verified, the fans should be run through a sweep of the full range of operating speeds that are expected to check for any vibration issues. If any areas of concern are located, it is recommended to lock out those frequencies using the VFD (see lock out frequencies or skip frequencies in the VFD manual). This will ensure that the fans will never operate continuously at those points, but will rather pass through them to get to the desired points of operation.

## Fan Startup

Start and run fan. See Figure 68 for proper fan rotation. Observe the rotation. If the fan operates backward, reverse two legs of the three-phase motor connections.

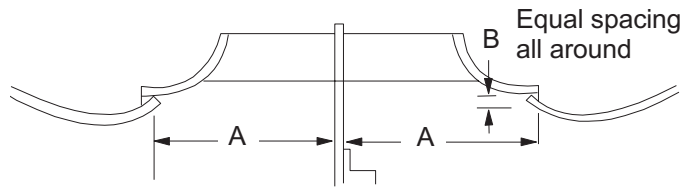
**NOTE:** Variable pitch fan drives usually are provided for operation in the mid-speed adjustment range. However, the drives usually ship with the adjustment opened up for minimum fan speed. Adjust the drives for the proper airflow. See Fan Drive on page 59.

## After the First 48 Hours of Operation

1. Disconnect and lock electrical power source.
2. Check tightness of all bearing, wheel, and sheave setscrews (or capscrews). See Table 28 on page 42.
3. Recheck belt tension and adjust if necessary. Belts that are tensioned sufficiently to slip one to two seconds at startup perform satisfactorily, extending life and reducing vibration. If re-tensioning is necessary, be certain to retain sheave alignment.

## Fan Wheel Alignment

**Figure 63: Wheel-to-Inlet Tunnel Relationship (Airfoil Type Fan Wheels (Housed))**



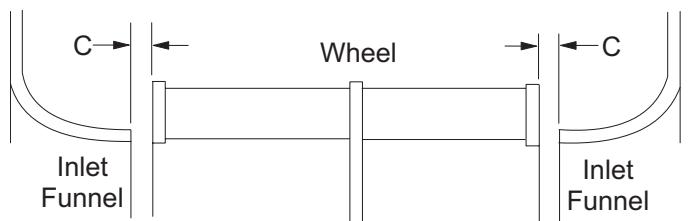
**Table 22: Wheel-to-Inlet Funnel Relationship (Airfoil Type)**

Diameter – in.	A in. (mm)	B in. (mm)
<b>Unit sizes 003 to 035</b>		
13.22	4.56 (116)	0.21 (5.33)
14.56	5.06 (129)	0.21 (5.33)
16.18	5.62 (143)	0.21 (5.33)
17.69	6.90 (175)	0.22 (5.59)
21.56	7.59 (193)	0.24 (6.10)
24.00	8.45 (215)	0.23 (5.84)
<b>Unit sizes 040 to 090</b>		
20.00	7.19 (183)	0.31 (7.87)
22.25	7.69 (195)	0.33 (8.38)
24.50	8.56 (217)	0.31 (7.87)
27.00	9.47 (241)	0.63 (16.00)
30.00	10.47 (266)	0.39 (9.91)
33.00	11.75 (298)	0.38 (9.65)
36.50	12.78 (325)	0.38 (9.65)
40.25	14.31 (363)	0.50 (12.70)

**Note:**

1. To obtain rated air performance, dimensional relationship must be held.
2. To obtain dimension A, loosen setscrews in wheel hub(s), shifting wheel(s) axially as needed, and retightening setscrews.
3. To obtain dimension B, loosen screw and washer fasteners around periphery of funnel(s), shifting funnel radially as required, and re-torquing fasteners.

**Figure 64: Wheel-to-Inlet Funnel Relationship (Forward Curved Type Fan Wheels)**

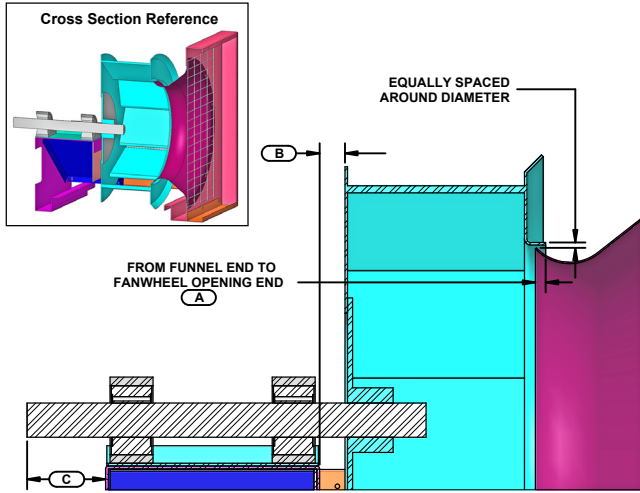


**Table 23: Wheel-to-Inlet Funnel Relationship (Forward Curved Type Fan Wheels)**

Diameter – in.	C in. (mm)
<b>Unit Sizes 003 to 035</b>	
9 × 4	0.25 (6.35)
9 × 7	0.13 (3.30)
9 × 9	0.25 (6.35)
10	0.22 (5.59)
12	0.35 (8.89)
15	0.44 (11.18)
18	0.25 (6.35)
20 (Class 1 & 2)	0.73 (8.54)
22.5 (Class 1 & 2)	0.59 (14.99)
24.5 (Class 1 & 2)	0.56 (14.22)
<b>Unit Sizes 040 to 090</b>	
20 (Class 1 & 2)	0.24 (6.10)
22.38 (Class 1 & 2)	0.41 (10.41)
25 (Class 1 & 2)	0.47 (11.94)
27.62 (Class 1 & 2)	0.47 (11.94)
30 (Class 1 & 2)	0.47 (11.94)
33 (Class 1 & 2)	0.50 (12.70)
36 (Class 1 & 2)	0.75 (19.05)

**Note:**  
 1. To obtain rated air performance, dimensional relationship must be held.  
 2. Adjust dimension C by loosening wheel hub setscrews, shifting wheel(s) axially as needed, and retightening setscrews

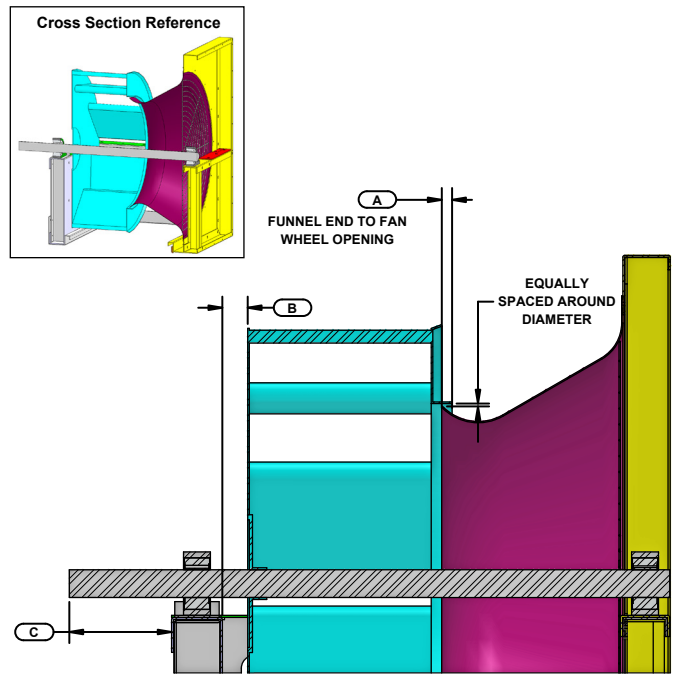
**Figure 65: Wheel-to-Inlet Funnel Relationship (13 to 36 Belt-Drive Plenum Fan)**



**Table 24: Wheel-to-Inlet Funnel Relationship (13 to 36 Belt-Drive Plenum Fan)**

Wheel-Funnel Parameters in. (mm)			
Size – in.	A	B	C
13	0.25 (6.35)	0.91 (23.11)	3.50 (88.9)
15	0.25 (6.35)	0.91 (23.11)	3.50 (88.9)
16	0.25 (6.35)	0.91 (23.11)	3.50 (88.9)
18	0.38 (88.9)	0.86 (21.84)	3.88 (98.55)
20	0.42 (10.67)	1.11 (28.19)	3.88 (98.55)
22	0.45 (11.43)	1.11 (28.19)	3.88 (98.55)
24	0.51 (12.95)	1.11 (28.19)	3.88 (98.55)
27	0.55 (13.97)	1.36 (34.54)	4.50 (114.3)
30	0.62 (15.75)	1.36 (34.54)	4.50 (114.3)
33	0.55 (13.97)	1.50 (38.1)	5.00 (127.0)
36	0.63 (16.0)	1.50 (38.1)	5.00 (127.0)

**Figure 66: Wheel-to-Inlet Funnel Relationship (40 to 60 Belt-Drive Plenum Fan)**



**Table 25: Wheel-to-Inlet Funnel Relationship (40 to 60 Belt-Drive Plenum Fan)**

Wheel-Funnel Parameters in. (mm)			
Size – in.	A	B	C
40	0.82 (20.83)	2.00 (50.8)	4.88 (121.92)
44	0.91 (23.11)	2.25 (57.15)	5.50 (139.7)
49	1.00 (25.4)	2.50 (63.5)	5.50 (139.7)
54	1.10 (27.94)	2.50 (63.5)	5.50 (139.7)
60	1.23 (31.242)	3.00 (76.2)	5.50 (139.7)

**Table 26: Wheel to Inlet Funnel Relationship (Direct-Drive Class II Fans)**

Fan Size – in.	Overlap – in. (mm)
11	0.25 (6.35)
12	0.25 (6.35)
15	0.25 (6.35)
16	0.38 (9.65)
18	0.38 (9.65)
20	0.41 (10.41)
22	0.45 (11.43)
24	0.50 (12.7)
27	0.55 (13.97)
30	0.61 (15.49)
33	0.67 (17.0)
36	0.75 (19.05)
40	0.82 (20.82)
44	0.91 (23.11)

**Table 27: Wheel to Inlet Funnel Relationship (Direct-Drive Class III Fans)**

Fan Size – in.	Overlap – in. (mm)
13	0.12 (3.0)
15	0.19 (4.82)
16	0.25 (6.35)
18	0.31 (7.87)
20	0.38 (9.652)
22	0.44 (11.17)
24	0.50 (12.7)
27	0.56 (14.22)
30	0.62 (16.76)
33	0.75 (19.05)
36	0.81 (20.57)
40	0.88 (22.35)
44	0.94 (23.87)
49	1.0 (25.4)
54	1.06 (26.92)
60	1.12 (28.44)

## Setscrews

Setscrews on MPQ fan wheels must be installed using a calibrated torque wrench to the value listed below,  $\pm 5\%$ . The fasteners must be periodically checked to satisfy agency requirements for components on rotating machinery.

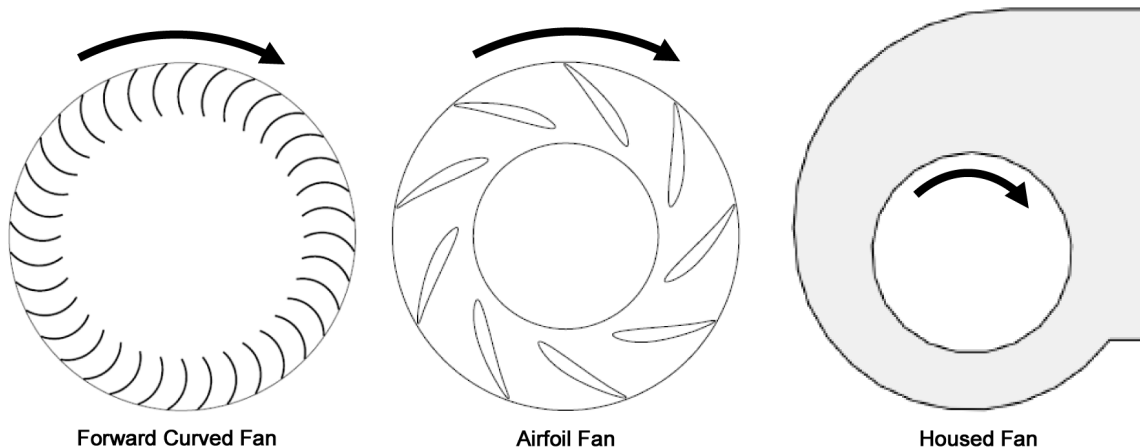
**Table 28: Setscrew Torque Specifications (Class II Plenum Fans Only)**

Fan Size	Setscrew Size	Torque (ft.-lb)	
		Aluminum	Steel
11/12/13	3/8	19.2	N/A
15	3/8	19.2	N/A
16	3/8	19.2	N/A
18	3/8	19.2	N/A
20	3/8	19.2	N/A
22	3/8	19.2	N/A
24	3/8	19.2	N/A
27	3/8	19.2	22
30	1/2	41.7	55
33	1/2	41.7	55
36	1/2	41.7	55
40	1/2	41.7	55
44	1/2	41.7	55
49	1/2	41.7	55
54	1/2	41.7	55
60	3/4	115	150

**Table 29: Bearing Collar and Wheel Hub Set Screw Torque (All Fans Except Class II Plenum Fans)**

Setscrew Diameter (in.)	Minimum torque
	ft/lbs (kg/m)
1/4	5.5 (0.76)
1/16	10.5 (1.45)
3/8	19.0 (2.63)
7/16	29.0 (4.01)
1/2	42.0 (5.81)
5/8	92.0 (12.72)

**Figure 67: Fan Wheel Rotation**



Fan wheel should rotate as shown

# Daikin Applied Fan Array

**⚠ WARNING**

Closing the damper on an operational fan could send the fan into surge that could produce fans stall, excessive vibration, unit damage, or personnel injury.

The Daikin Applied Fan Array is available with optional, factory mounted VFDs. See OM manuals OM 1190 and 1191 for details on the Daikin Applied supplied VFD.

Care should be taken when programming and synchronizing the drives in the Daikin Applied Fan Array such that all fans turn at the same speed. Fans running at unequal speeds can produce vibration and could stall a fan. Definition of fan numbering is given in Figure 68.

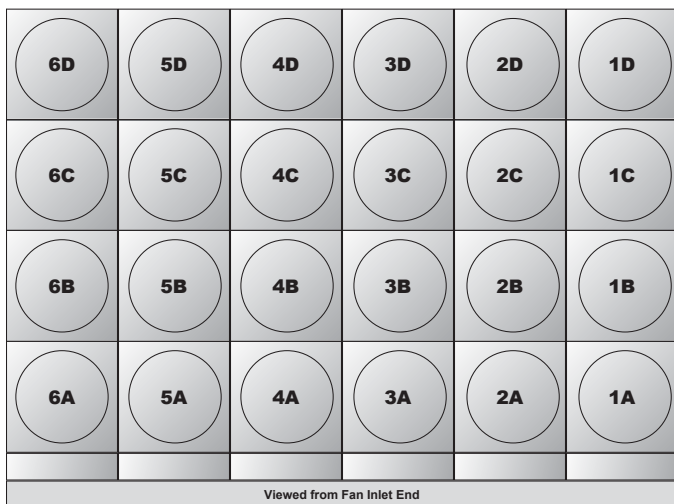
The Daikin Applied Fan Array is standard with a manual block off plate. The unit will ship with one block off plate that will come installed on fan 1A. This block off plate is to be removed before unit operation and stored outside of the air tunnel. In the event of a lost fan motor, the block off plate is installed on the non-functional fan to prevent air re-circulation. This is designed to be a temporary measure until this fan and/or motor is replaced. After fan and/or motor replacement the block off plate is to be removed and stored outside of the air tunnel.

The Daikin Applied Fan Array has an optional gravity actuated block off damper. These dampers are equipped with counter weights.

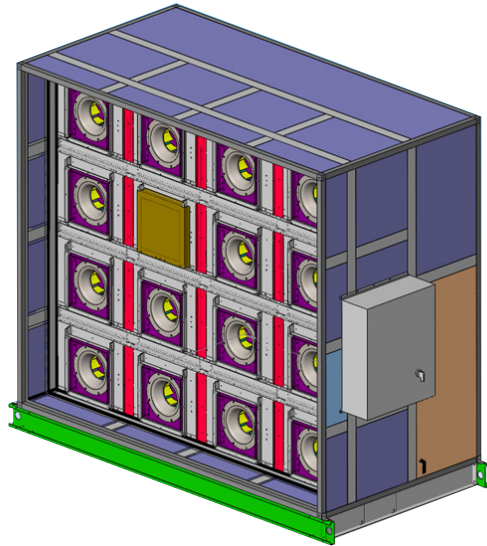
The Daikin Applied Fan Array has an optional actuated block off damper. These dampers are designed to prevent air recirculation in the event of a lost fan. Care should be taken that the damper actuator only be given a close signal if the fan is not operational (motor burnout for example).

The Daikin Applied Fan Array can be equipped with a fan blank off plate. See Figure 70 with a block off plate mounted to fan 3C. If the unit is ordered with the manual block off plate, it will be installed to fan 1A. This plate has to be removed before start up.

**Figure 68: Daikin Applied Fan Array Configuration**



**Figure 69: Fan Array with Block Off Plate**



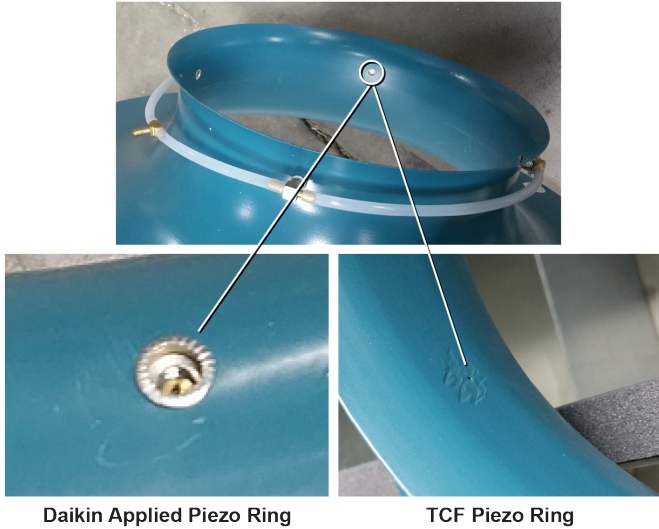
## Optional Piezometer Ring Airflow Measurement Device

Piezometer rings are available as an option on direct drive plenum fans to measure airflow through the fan. The device consists of a piezometer ring mounted in the throat of the funnel and a static pressure tap mounted near the inlet of the funnel. The pressure drop is measured from the tap located near the inlet of the funnel to the piezometer ring in the throat. The inlet tap is connected to the high-pressure side of the transducer and the piezometer ring is connected to the low-pressure side.

See the equations and factors required to calculate flow using the piezometer ring.

**NOTE:** There are two manufacturer options for the piezometer ring. Care should be taken to ensure that the appropriate coefficients are used, otherwise airflow measurement may be incorrect. Reference Figure 70 to determine which piezometer ring you have.

**Figure 70: Determining the Manufacturer**



**Non-Standard Density Method**

The following equation is used to measure the flow for non-standard density:

$$ACFM = C1 \times A \times \sqrt{(\Delta P/\rho)}$$

where: A = Inlet funnel throat area (square feet) - from [Table 31](#) and [Table 33](#)

$\Delta P$  = The differential in static pressure from the piezometer ring and the inlet pressure tap (inches w.g.)

$\rho$  = Air density (pounds mass/cubic foot)

C1 = Value from [Table 30](#) and [Table 32](#)

**Standard Density Method**

The equation can be simplified by assuming standard density and assuming funnel dimensions match the drawing dimensions. [Table 31](#) and [Table 33](#) show the factor (K) for each fan size and type. The equation then becomes the following:

For standard air ( $\rho = 0.075 \text{ lb/ft}^3$ ):

$$ACFM = K \times \sqrt{(\Delta P)}$$

where: K = factor from [Table 31](#) and [Table 33](#)

$\Delta P$  = The differential in static pressure from the piezometer ring and the front pressure tap (inches w.g.)

**Table 30: DDPL Factors For Free and Ducted Inlet — Non Standard Density Method, TCF Piezo Ring**

Product	C1 Free Inlet	C1 Ducted Inlet
DDPL Size 11-16	753.06	794.06
DDPL Size 18-44	692.03	740.14

**Table 31: DDPL Factors For Free and Ducted Inlet — Standard Density Method, TCF Piezo Ring**

DDPL Size	Free Inlet K	Ducted Inlet K	Area A	Wheel Diameter
11 and 12	944.92	996.36	0.344	12.40
15	1206.40	1272.08	0.439	14.00
16	1518.58	1601.26	0.552	15.75
18	1821.92	1948.58	0.721	18.25
20	2185.80	2337.76	0.865	20.00
22	2713.93	2902.60	1.074	22.25
24	3285.02	3513.39	1.300	24.50
27	3997.61	4275.53	1.582	27.00
30	4945.21	5289.01	1.957	30.00
33	5968.62	6383.56	2.362	33.00
36	7290.21	7797.03	2.885	36.50
40	8869.55	9486.16	3.510	40.25
44	10827.92	11580.68	4.285	44.50

**Table 32: DDPL Factors for Free and Ducted Inlet – Non-Standard Density Method, Daikin Applied Piezo Ring**

DDPL Size	C1 Free Inlet	C1 Ducted Inlet
12	783.66	792.43
15	767.48	763.62
16	732.77	757.40
18	612.29	619.65
20	653.83	652.65
22	674.42	673.16
24	679.53	681.34
27	656.57	660.15
30	691.07	692.12
33	675.26	677.89
36	675.83	676.67
40	699.51	694.22
44	681.07	681.01

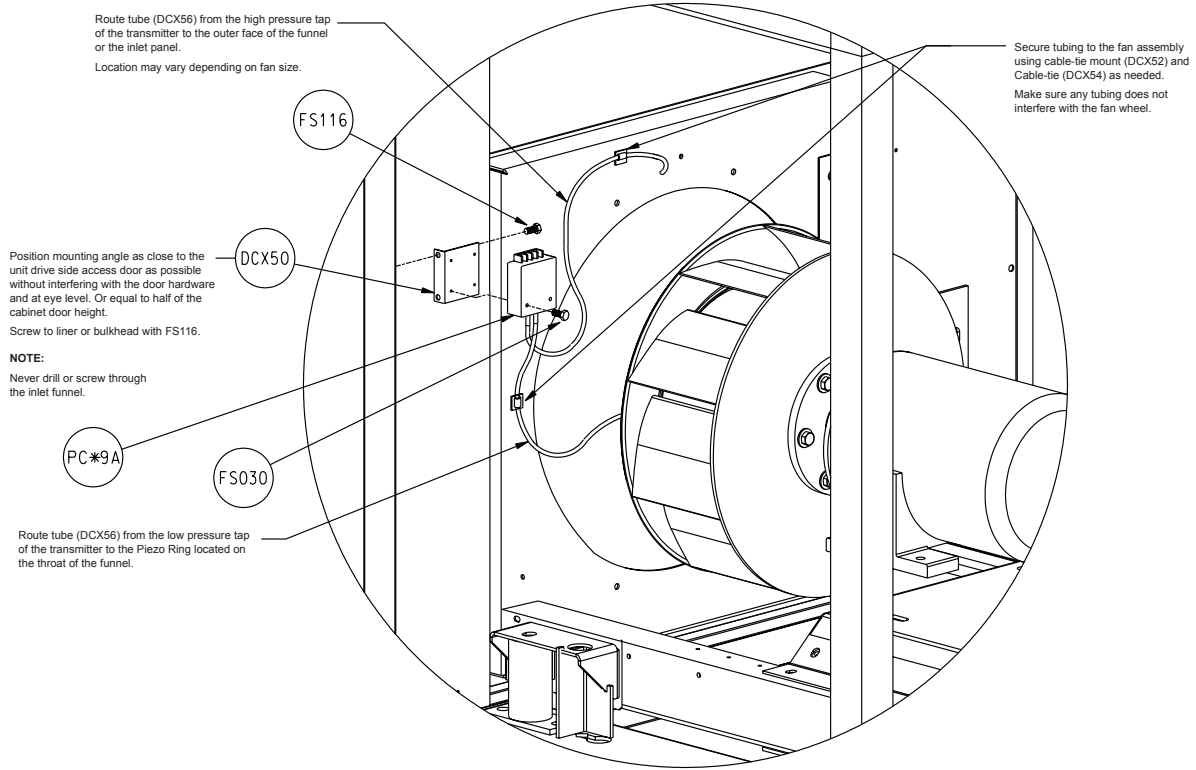
**Table 33: DDPL Factors for Free and Ducted Inlet – Standard Density Method, Daikin Applied Piezo Ring**

DDPL Size	Free Inlet K	Ducted Inlet K	Area A	Wheel Diameter
12	1004.66	1016.46	0.344	12.40
15	1261.99	1260.20	0.439	14.00
16	1526.96	1572.35	0.552	15.75
18	1675.69	1672.77	0.721	18.25
20	2117.33	2110.61	0.865	20.00
22	2710.75	2693.35	1.074	22.25
24	3312.67	3319.41	1.300	24.50
27	3901.60	3929.94	1.582	27.00
30	5017.64	5033.71	1.957	30.00
33	5942.72	5979.46	2.362	33.00
36	7274.52	7316.07	2.885	36.50
40	9179.91	9089.14	3.513	40.25
44	10891.71	10880.24	4.285	44.50

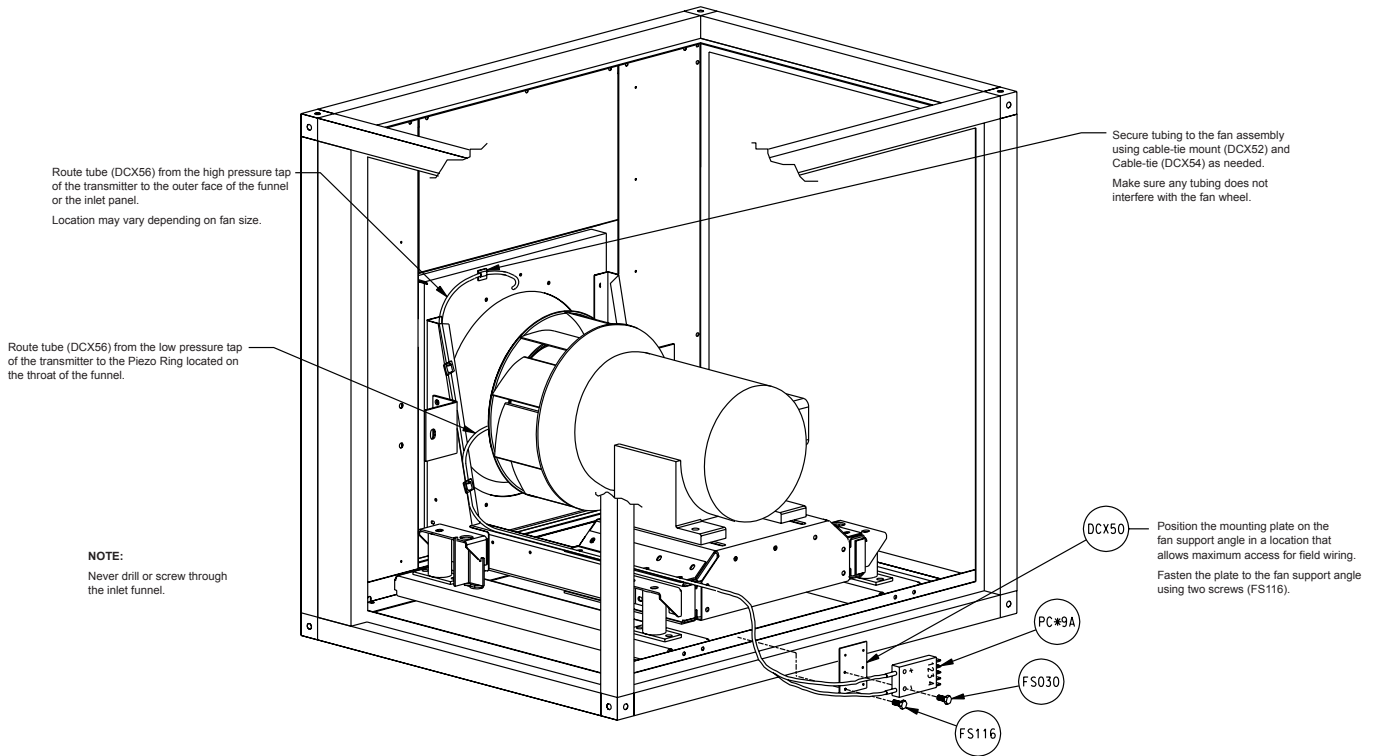
**Optional Transducer for Piezometer Rings**

A transducer is available for Piezometer rings. Factory mounting locations for the fan transducer is shown in [Figure 70](#) for direct-drive plenum fans. [Figure 71](#) shows the installation for fan array. Wiring for the transducer is field-supplied and installed.

**Figure 71: Direct-drive Plenum Fan Installation**



**Figure 72: Fan Array Installation**



# Daikin Applied ECM Fan Array

The Daikin Applied ECM fan array is made of an impeller, an electronically commutated motor (ECM), and an inverter. It is installed as an assembly, and in the event of failure, the entire assembly must be replaced. Bearings are permanently sealed and lubricated, so no periodic greasing is necessary.

A minimum 24" access section is recommended downstream of the Daikin Applied ECM Fan Array section to gain access to the fans. If an access section is not selected downstream of the fan array, there will be very limited access to the fans for service/replacement.

The Daikin Applied ECM fan array has an optional gravity actuated block off damper. These dampers are equipped with counter weights.

The Daikin Applied ECM Fan Array has an option for a block off plate that can be ordered as a parts kit from the Daikin Applied Parts group. A minimum 24" access section is recommended upstream of the Daikin Applied ECM Fan Array section to install block-off plate (see [See Block-Off Plate Installation on page 48](#)).

## ECM Control Options

1. ANALOG CONTROL
  - i. None: 0-10V speed control.
  - ii. Basic: 0-10V speed control with HOA (manual/auto) switch and potentiometer.
2. DIGITAL CONTROL
  - i. Premium controls: MicroTech unit controller with Modbus.

The entire array is controlled via a 0-10V signal for analog controls. The control signal (0-10V) is wired to the Daikin Applied low voltage terminal block (TB01) and connects to points as noted in schematics shown in [Figure 80 through Figure 84](#).

**NOTE:** Fans may continue to draw electrical current when not in operation.

**NOTE:** The Daikin Applied ECM Fan Array control schematic is included in the ECM fan control panel.

The digital controls option is a DDC controller allowing for equipment configuration, monitoring, and troubleshooting. The controller is either factory installed on the unit or remote mounted.

### Example:

A Delta fan motor with "Basic" controls connects the control signal to points 2 and 4 on the Daikin Applied low voltage terminal block (TB01). Fan enable is controlled by a field supplied relay and connects to points 1 and 3. The fan array fault is wired to points 5 and 6. If any fan in the fan array faults, the contact connection between 5 and 6 will open.

**NOTE:** If an enable relay is not needed, add a jumper at point 1 and 3.

## Remote Mounted Panel

The control panel can be ordered for remote mounting. For remote mounted panels, the control wiring for the individual fans will be provided; however, the control wiring to connect the final fan to the control panel and all of the power wiring must be field-provided. If control panel is too heavy to be mounted on unit then it will be shipped separately and must be remote mounted.

30 foot long high voltage harnesses may be ordered through the Daikin Applied Parts Group using part number 910232406. One high voltage harness is required per fan (see [Figure 73](#)).

If wiring harnesses are not purchased through Daikin Applied, follow the below instructions to install the wiring.

1. High Voltage Power Wiring:
  - a. Remove the plate on the back of each fan.
  - b. Remove the provided high voltage plug and wiring shown in [Figure 73](#).
  - c. Cut, strip, and connect wiring directly to each motor terminal shown in [Figure 73](#), paying attention to the correct phasing. Reference the wiring schematic provided with unit.
  - d. Cut, strip, and connect the other end of the wiring to the Manual Motor Protector (MMP) in the control panel, paying attention to phasing. Reference the wiring schematic provided with unit.

**NOTE:** [Figure 74](#) shows a single fan control box. There will be 1 MMP per fan in the array to connect each fan to.

2. Low Voltage Control Wiring:
  - a. Verify same plugs and terminals are used for all control options and fan types.
  - b. 22-gauge Cat5 wiring, a standard 6-circuit female Molex plug (39-01-2061), and six Molex crimp terminals (39-00-0040) are required ([Figure 75](#)). The finished harness will have a plug on one end and stripped wire on the other end.
  - c. Attach the wiring to the Molex crimp terminal and insert into the Molex plug. See [Figure 76](#) for correct crimp terminal locations; reference schematic shipped with unit for wiring numbers (out of ECM01). Connect to the male plug that is on the last fan in the array.
  - d. Insert the stripped wire end into the terminals in the control panel, following the wiring schematic shipped with the unit. Terminals are shown in [Figure 74](#).

Figure 73: Fan - High Voltage Wiring

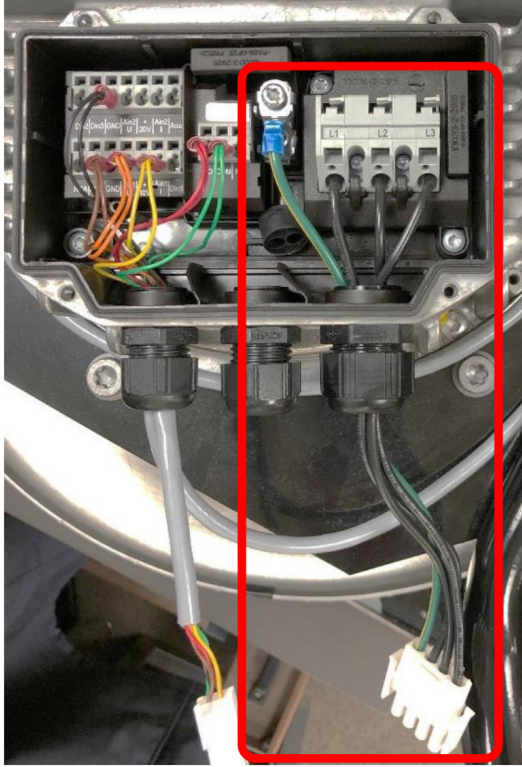


Figure 74: Single Fan Control Panel - High Voltage Wiring (in red); Low Voltage Wiring (in blue)

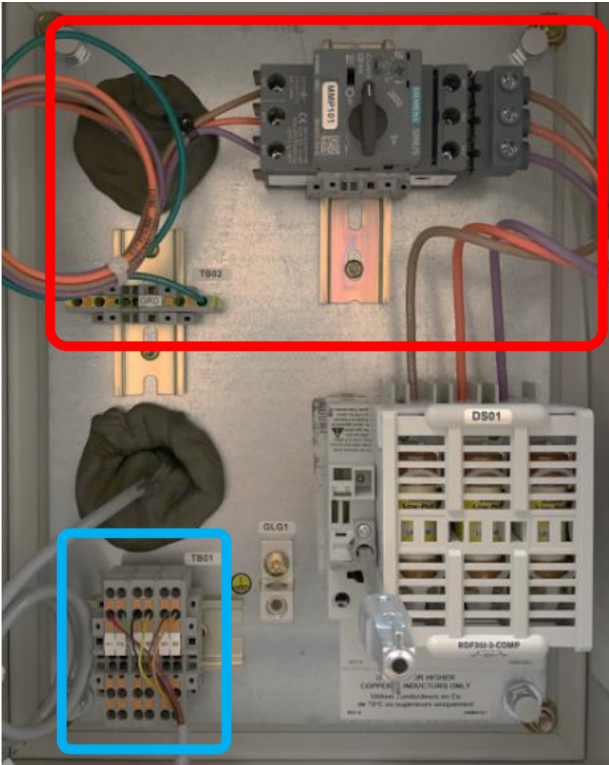


Figure 75: Required Molex Plug and Crimp Terminals

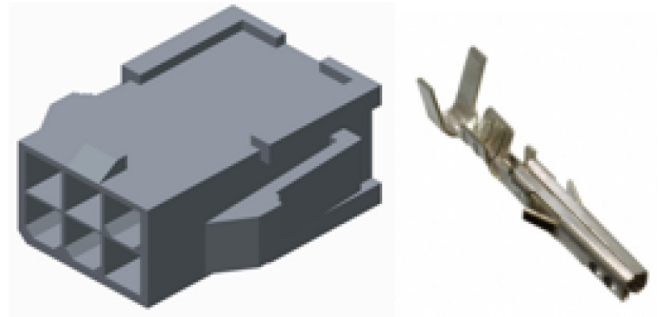


Figure 76: Molex Plug Crimp Terminal Locations

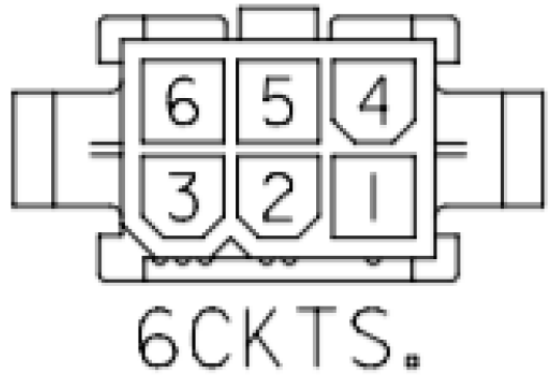
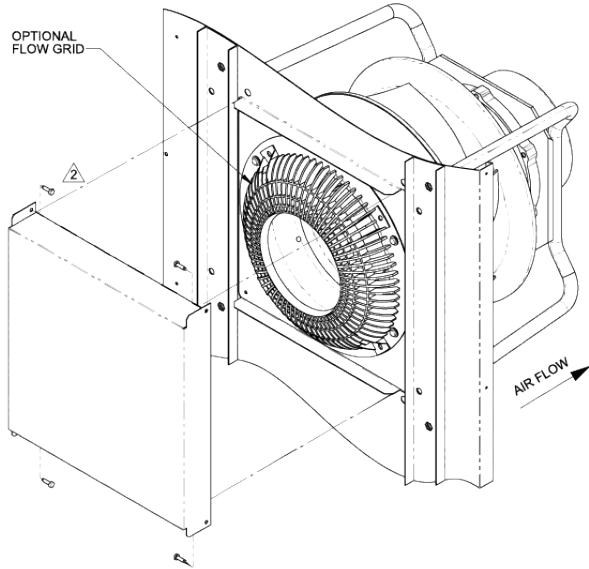


Figure 77: Daikin Applied ECM Fan Array



Figure 78: Block-Off Plate Installation



NOTES:  
 1) INSTALL BACK-DRAFT PANEL AS SHOWN OVER NON-FUNCTIONING FAN  
 2) SECURE USING (4) SELF DRILL/TAPPING SCREWS

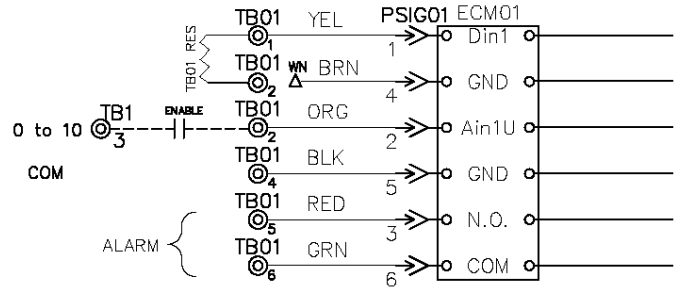
Table 34: Block-Off Plate Part Numbers

Block-Off Plate	Fan Size	kW
910198700	355	All
910198701	450	All
910311272	560	All
910311272	630	5.9; 6.3
910311273	630	7.1; 9.8

Figure 79: EBM Gen 2 Motor

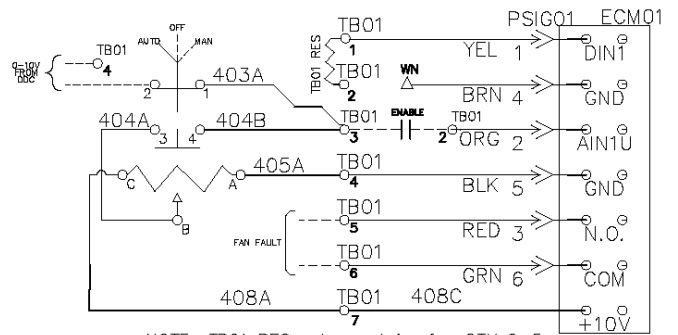


Figure 80: EBM Gen 2 Motor - Control Wiring with No Controls



NOTE: TB01 RES only used for fan QTY 2-5

Figure 81: EBM Gen 2 Motor - Control Wiring with Manual/ Auto (Basic) Controls



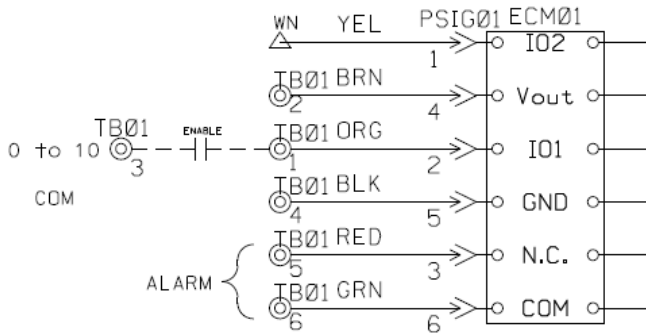
NOTE: TB01 RES only used for fan QTY 2-5

NOTE: For ECM Fan DDC controller information and wiring, reference ED 19123.

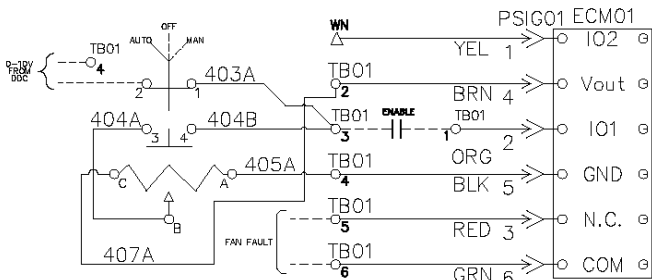
Figure 82: EBM Gen 3 Motor



**Figure 83: EBM Gen 3 Motor - Control Wiring with No Controls**

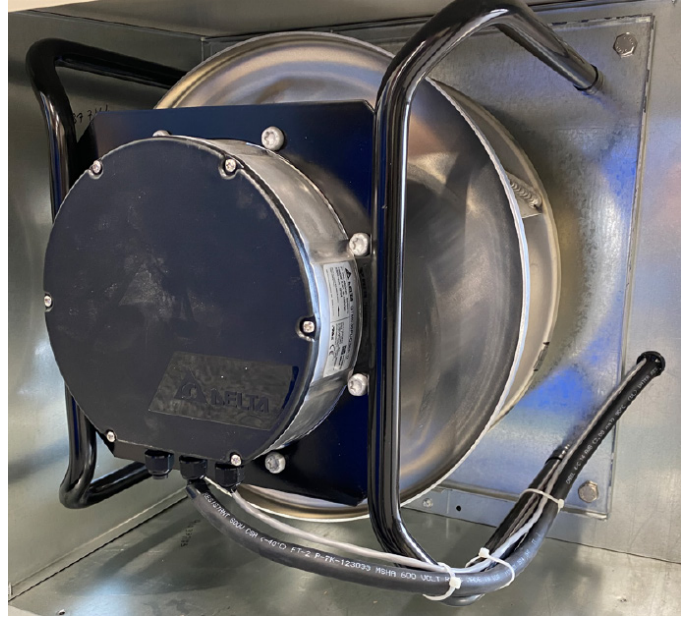


**Figure 84: EBM Gen 3 Motor - Control Wiring with Manual/ Auto (Basic) Controls**

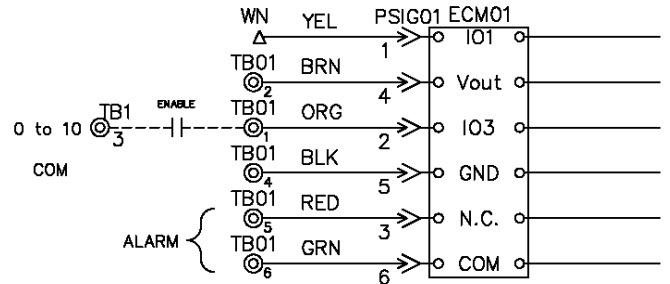


**NOTE:** For ECM Fan DDC controller information and wiring, reference ED 19123.

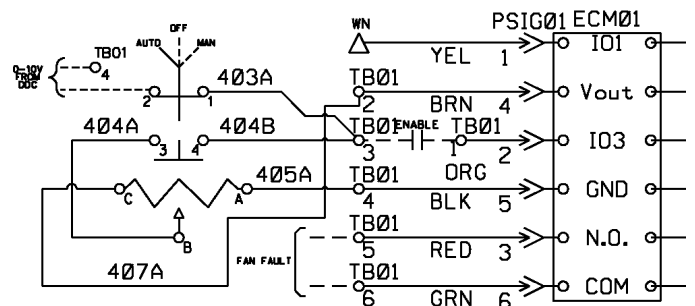
**Figure 85: Delta Motor**



**Figure 86: Delta Motor - Control Wiring with No Controls**

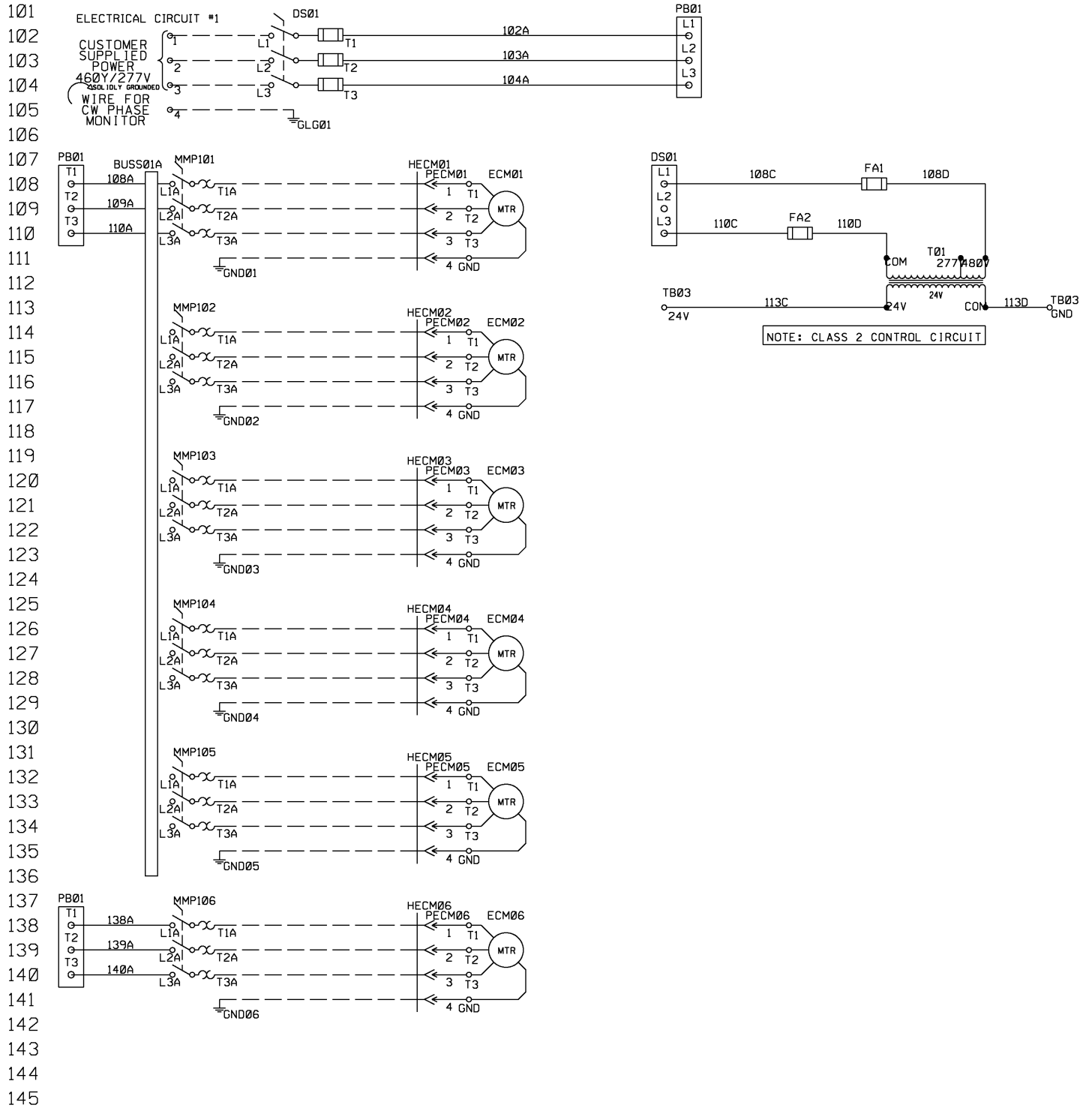


**Figure 87: Delta Motor - Control Wiring with Manual/ Auto (Basic) Controls**



**NOTE:** For ECM Fan DDC controller information and wiring, reference ED 19123.

Figure 88: Line Voltage Wiring - All Fans





## Optional Piezometer Point Airflow Measurement Device

A Piezometer point is an option with ECM Fans to measure airflow through the fan. The device consists of a piezometer point mounted in the throat of the funnel and a static pressure tap mounted near the inlet of the funnel. The pressure drop is measured from the tap located near the inlet of the funnel to the piezometer point in the throat. The inlet tap is connected to the high-pressure side of the transducer and the piezometer point is connected to the low-pressure side.

A transducer is always factory supplied when the Piezometer Option is selected with an ECM Fan. Figure 90 shows the installation for ECM Fans.

See the equations and factors required to calculate flow using the piezometer point:

### Non-Standard Density Method

The following equation is used to measure the flow for non-standard density:

$$ACFM = C1 \times A \times \sqrt{(\Delta P/\rho)}$$

where: A = Inlet funnel throat area (square feet) - from Table 36

$\Delta P$  = The differential in static pressure from the piezometer ring and the inlet pressure tap (inches w.g.)

$\rho$  = Air density (pounds mass/cubic foot)

C1 = Value from Table 35

### Standard Density Method

The equation can be simplified by assuming standard density and assuming funnel dimensions match the drawing dimensions. Table 35 shows the factor (K) for each fan size and type. The equation then becomes the following:

For standard air ( $\rho = 0.075 \text{ lb/ft}^3$ ):

$$ACFM = K \times \sqrt{(\Delta P)}$$

where: K = factor from Table 36

$\Delta P$  = The differential in static pressure from the piezometer ring and the front pressure tap (inches w.g.)

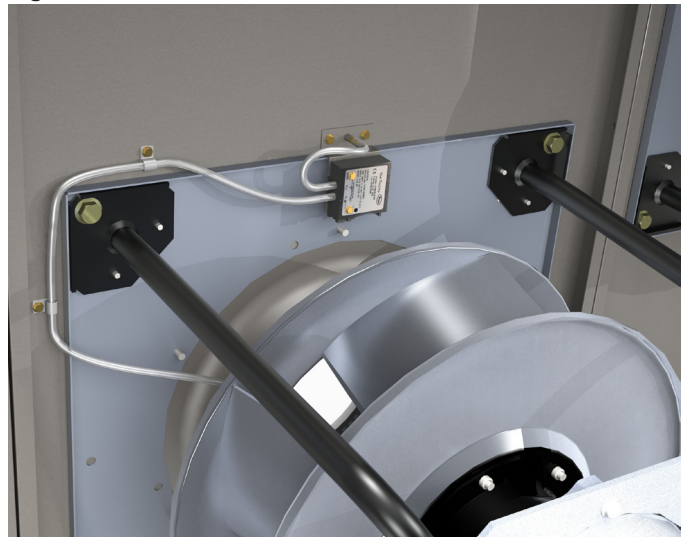
**Table 35: ECM Factors for Free and Ducted Inlet — Non-Standard Density Method**

ECM Size	C1 Free Inlet	C1 Ducted Inlet
355	774.47	774.47
450	783.31	783.31
560	658.54	658.54
630	666.68	666.68
355D	802.05	802.05
450D	783.31	783.31

**Table 36: ECM Factors for Free and Ducted Inlet — Standard Density Method**

ECM Size	Free Inlet K	Ducted Inlet K	Area A
355	1372.74	1372.74	0.485
450	2226.07	2226.07	0.778
560	3224.71	3224.71	1.341
630	4058.68	4058.68	1.667
355D	1459.58	1459.58	0.498
450D	2283.43	2283.43	0.798

**Figure 90: Piezometer Transducer**



# Fan Operating Limits

Do not exceed the operating limits in Table 37 through Table 41. A fan wheel operated beyond the rpm and temperature limits shown can suffer permanent distortion or fracture. The resulting unbalance can cause severe unit vibration.

**Table 37: Unit Sizes 003 to 035**

Fan Operating Limits										
<b>Forward curved—housed</b>										
Diameter	9 × 4	9 × 7	9 × 9	10.62	12.62	15	18	20	22.25	24.50
Maximum rpm Class I	N/A	2189	2223	1934	1614	1328	1155	1050	944	858
Maximum rpm Class II	2700	2854	2896	2518	2091	1725	1450	1200	1030	910
<b>Airfoil—housed</b>										
Diameter	13.22	14.56	16.19	19.69	21.56	24.00				
Maximum rpm Class I	3000	3000	2300	2000	1700	1500				
Maximum rpm Class II	4335	3918	3457	2858	2427	2255				

**Table 38: Unit Sizes 040 to 090**

Fan Operating Limits							
<b>Forward curved—housed</b>							
Diameter	20	22.38	25	27.62	30.25	33	36
Maximum rpm Class I	1010	930	790	690	650	600	560
Maximum rpm Class II	1281	1178	1011	910	835	763	715
<b>Airfoil—housed</b>							
Diameter	20	22.25	24.5	27	30	33	36.5
Maximum rpm Class I	2077	1875	1691	1479	1328	1209	1073
Maximum rpm Class II	2703	2413	2199	1928	1730	1579	1401

**Table 39: Operating Limits—Belt-Drive Plenum Fans**

Fan Operating Limits																
<b>Belt-Drive Plenum Fans</b>																
Size	13	15	16	18	20	22	24	27	30	33	36	40	44	49	54	60
Maximum rpm Class II	3909	3468	2820	2930	2674	2403	2183	1860	1783	1620	1465	1329	1202	1091	986	891
Maximum rpm Class III	4000	4000	3887	3735	3409	3065	2780	2423	2182	1984	1759	1598	1447	1314	1178	1071

**Table 40: Operating Limits—Twin Fans**

Fan Operating Limits						
<b>Twin Fans</b>						
Diameter	9 × 9	10.62	12.62	15	18.12	20
Maximum rpm	2575	2400	2000	1700	1400	1200
Maximum HP	10	15	15	30	40	40

**Table 41: Operating Limits—Direct-Drive Plenum Fans**

Fan Operating Limits																		
<b>Belt-Drive Plenum Fans</b>																		
Size	11	12	13	15	16	18	20	22	24	27	30	33	36	40	44	49	54	60
Maximum rpm Class II	4000	4000	—	3909	3650	3650	2674	2403	2183	1981	1783	1620	1465	1329	1202	—	—	—
Maximum rpm Class III	—	—	4000	4000	3887	3735	3409	3065	2780	2423	2182	1984	1759	1598	1447	1314	1178	1071

## Fan Vibration Levels

Each unit as shipped is trim balanced to operate smoothly. To provide satisfactory operation after shipping and installation, use the accepted industry guidelines for field balancing fans. See Table 42.

**Table 42: Vibration Levels**

Fan Speed (rpm)	Vibration
800 or less	5 mils maximum displacement
801 or greater	0.20 in/sec. maximum velocity

**NOTE:** Excessive vibration from any cause contributes to premature fan and motor bearing failure. Monitor overall vibration levels every six months of operation. An increase in levels is an indication of potential trouble.

## Vibration Causes

1. Wheel imbalance.
  - a. Dirt or debris on wheel blades.
  - b. Loose set screws in wheel hub or bearing-to-shaft.
  - c. Wheel distorted from overspeed.
2. Bent shaft.
3. Drive faulty.
  - a. Variable pitch sheaves—Axial and radial runout of flanges; uneven groove spacing; out of balance. Also similar faults in driven sheave.
  - b. Bad V-belts; lumpy, or mismatched; belt tension too tight or too loose.
4. Bad bearings, loose bearing hold-down bolts.
5. Motor imbalance.
6. Fan section not supported evenly on foundation.

# Gas Phase Filtration Technology

Please refer to the manual provided with unit for installation, operation, and maintenance related to gas phase filtration technology, otherwise known as sorbent cleaners.

**NOTE:** In instances where more than one module is being applied, there is one main control box for line voltage and control voltage connections. This box will contain the controller and landing terminals for the control connection wires from the building. If more than one module is being applied, section splits may be present. If so, factory supplied wires will need to be routed into the provided junction box on each sorbent cleaner module. Conduit routing will be provided for these connections.

## Supplemental Hood Installation

**NOTE:** Supplemental hoods are designed to be mounted on the outside paneling/framing of a sections opening, and will have dimensions bigger than the opening.

1. Hoods are shipped loose and will need to be installed in the field. Each separate hood assembly will come with lifting brackets, located at the top most point of the hood. This can be seen in [Figure 91](#). These must be used when lifting the hoods to avoid damage.
2. These hoods mount to the external wall/frame of the unit. They are not recessed into the section walls. Once the hood is in place against the unit, screw in the top and bottom screws. Once done, the lifting mechanism is no longer necessary. See [Figure 92](#) and [Figure 93](#).
3. The side panels on the hoods need to be removed in order to screw and secure the side flanges to the unit. Remove the screws from the side panels, and physically remove the panels to gain access to pre-cut holes. This will allow access with a drill. Drill screws into all pre-cut holes. [Figure 94](#) shows the panel, [Figure 95](#) shows the side panel removed and gaskets.
4. Re-install the side panels on both sides of the unit. Gaskets have already been installed to prevent water from entering in these panels.
5. Some hoods may require fitting under the framing of the roof. See [Figure 97](#).
  - a. Remove fasteners along roofline in the hood area.
  - b. Slide hood back flange behind roof mounting channel
  - c. Re-install fasteners along roof line
6. Apply caulk between the hood and unit walls on the sides and top edge of the hood. This will ensure no water enters the hoods and airstream.

**Figure 91: Hood assembly showing lifting brackets**



**Figure 92: Top flange of hood screwed to the unit while held in place by lifting mechanism**



**Figure 93: Bottom flange of hood screwed to unit while held in place by lifting bracket**



**Figure 94: Side panel of hood (one on both sides) needed to be removed to secure hood**



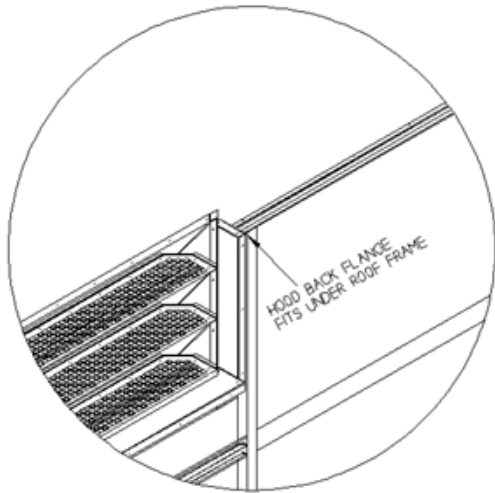
**Figure 95: Showing what a removed side panel looks like, with gaskets on inside**



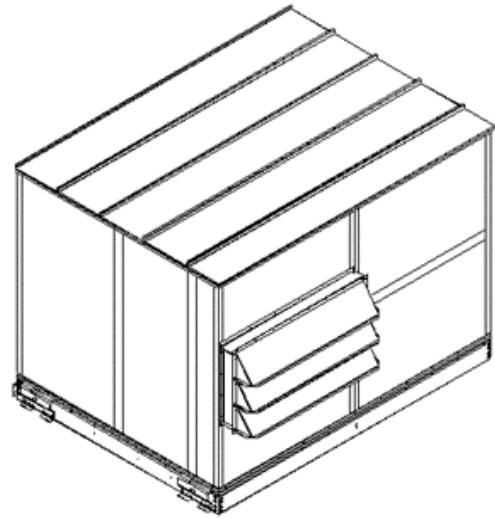
**Figure 96: Side flange to be secured once side panel is removed**



**Figure 97: Hood mounted under roofline framing**



**Figure 98: Final installation**



## Supplemental Roof and Base Installation

### Sectioned Base

**NOTE:** The supplemental base is built to sit on top of an already installed curb.

1. Apply lubricant to the curb gasket to allow sections to slide together once sat on the curb.
2. Bolt together the brackets on base at section splits as seen in [Figure 99](#). The same brackets are used to secure the vestibule base to the unit base.

**NOTE:** There is no gasket between the section splits. Supplemental bases have integrated drip shields.

3. Caulk between frame channels and roof panels at all section splits before joining.

**NOTE:** The supplemental base contains a minimum of four lifting brackets per shipping section, or more if necessary. They will never be further than 100" apart. See [Figure 100](#).

4. Apply sealant at section splits and roofing line at section splits.
5. Avoid caulking/sealing the underside of base rails, these act as weep locations for water and sealing that could cause water to slightly pool up on inside of base rail.
6. Apply roof caps at section splits.

**Figure 99: Section split brackets**

## Unitized Base

**NOTE:** The Supplemental base is built to sit on top of the already installed curb.

**NOTE:** The supplemental base contains a minimum of four lifting brackets per shipping section, or more if necessary. They will never be further than 100" apart. See [Figure 100](#).

1. Use brackets to secure the vestibule base to the unit base, as seen in [Figure 99](#).

**Figure 100: Lifting lugs located on base rail**

# Service and Maintenance

## Periodic Maintenance

1. Check all moving parts for wear every six months.
2. Check bearing collar, sheave, and wheel hub setscrews, sheave capscrews, and bearing hold-down bolts for tightness every six months.
3. Annually check and snug all electrical connections. Inspect for signs of water damage such as corrosion and repair if necessary. Check ground conductor and connection integrity. Service if needed.

## Ball Bearing Lubrication

**CAUTION**  
 Bearing overheating potential. Can damage the equipment. Do not over-lubricate bearings. Use only a high grade mineral grease with a 200°F safe operating temperature. See below for specific recommended lubricants.

### Motor Bearings

Supply and return fans—Supply and return fan motors should have grease added after every 2000 hours of operation. Using the following procedure, re-lubricate the bearings while the motor is warm, but not running. Use one of the greases shown in Table 43.

**NOTE:** Direct Drive Class II fans that are supplied with TECO motors have double shielded bearings on frame sizes 140T-280T. These bearings are pre-packed with a long life grease and are not re-greaseable. Larger frame size TECO motors are re-greaseable and follow the same lubrication recommendations as all other motors.

1. Remove and clean upper and lower grease plugs.
2. Insert a grease fitting into the upper hole and add clean grease (Table 43) with a low pressure gun.
3. Run the motor for five minutes before replacing the plugs.

**NOTE:** Specific greasing instructions are located on a tag attached to the motor. If special lubrication instructions are on the motor, they supersede all other instructions.

**Table 43: Recommended Lubricants and Amounts for Fan Motor Bearings**

Mfr. Grease	NEMA Size	Amount to Add (oz.)
Texaco, Polystar	56 to 140	0.08
	140	0.15
or Polyrex EM (Exxon Mobil)	180	0.19
	210	0.30
or Rykon Premium #2	250	0.47
	280	0.61
or Penzoil Pen 2 Lube	320	0.76
	360	0.81
	400	1.25
	440	2.12

## Fan Shaft Bearings

**CAUTION**  
 For safety, stop rotating equipment. Add one half of the recommended amount shown in Table 43. Start bearing, and run for a few minute Stop bearing and add the second half of the recommended amount. A temperature rise, sometimes 30°F (1°C), after re-lubrication is normal. Bearing should operate at temperature less than 200°F (94°C) and should not exceed 225°F (107°C) for intermittent operation. For a re-lubrication schedule, see Table 44. For applications that are not in the range of the table, contact Daikin Applied.

**CAUTION**  
 The tables below state general lubrication recommendations based on our experience and are intended as suggested or starting points only. For best results, specific applications should be monitored regularly and lubrication intervals and amounts adjusted accordingly.

Any good quality lithium or lithium complex base grease, using mineral oil, conforming to NLGI grade 2 consistency, and an oil viscosity of 455-1135 SUS at 100°F (100-200 cSt at 40°C) may be used for re-lubrication.

Compatibility of grease is critical. Re-lubricatable bearings are supplied with grease fittings or zerks for ease of lubrication with hand or automatic grease guns. Always wipe the fitting and grease nozzle clean.

**Table 44: Re-lubrication Intervals**

(Use NLGI #2 Lithium or Lithium Complex Grease)

Speed	Bearing Temperature	Cleanliness	Relub. Intervals
100 rpm	Up to 120°F (50°C)	Clean	6 to 12 months
500 rpm	Up to 150°F (65°C)	Clean	2 to 6 months
1000 rpm	Up to 210°F (100°C)	Clean	2 weeks to 2 months
1500 rpm	Over 210°F (100°C) to 250°F (120°C)	Clean	Weekly
Above 1500 rpm	Up to 150°F (65°C)	Dirty/wet	1 week to 1 month
Max catalog rating	Over 150°F (65°C) to 250°F (120°C)	Dirty/wet	Daily to 2 weeks
	Above 250°F (120°C)		Contact Browning

**Table 45: Recommended Fan Re-lubrication Grease Charge**

Shaft Size – in. (mm)	Oz (g)
1/2 to 3/4 (20)	0.03 (0.85)
7/8 to 1-3/16 (25-30)	0.10 (2.84)
1-1/4 to 1-1/2 (35-40)	0.15 (4.25)
1-11/16 to 1-15/16 (45-50)	0.20 (5.67)
2 to 2-7/16 (55-60)	0.30 (8.51)
2-1/2 to 2-15/16 (65-70)	0.5 (15.59)
3 to 3-7/16 (75-80)	0.85 (24.10)
3-1/2 to 4 (85-105)	1.5 (42.53)

## Fan Drive

### WARNING

Before servicing lock out and tag out all power to the unit. Fans or belts cause severe personal injury or death.

### WARNING

Do not open the hinged access door and screw-fastened access panels while the unit is operating. Moving parts and strong suction forces can cause severe personal injury or death.

Upon completion of the air balance, replace the variable pitched motor sheave with a properly sized, fixed sheave. A matching fixed sheave provides longer belt and bearing life and minimizes vibration. Initially, it is best to have a variable pitched motor sheave for the purpose of air balancing. Once the balance is achieved, fixed sheaves maintain balancing and alignment more effectively. Replace the adjustable sheaves with fixed sheaves.

With the electrical power disconnected, locked and tagged out, measure the diameter of the V-belt outer surface where it passes around the sheave (pitch diameter). Calculate fan speed from the motor nameplate rpm.

$$\text{Fan rpm} = \text{motor rpm} \times \frac{\text{Measured diameter at motor sheave}}{\text{Measured diameter at fan sheave}}$$

## VM and VP Variable Pitch Key Type Sheaves

### Mounting

1. Mount all sheaves on the motor or driving shaft with the setscrews **A** toward the motor.
2. Verify that both driving and driven sheaves are in alignment and that shafts are parallel.
3. Fit internal key **D** between sheave and shaft and lock setscrew **A** securely in place.

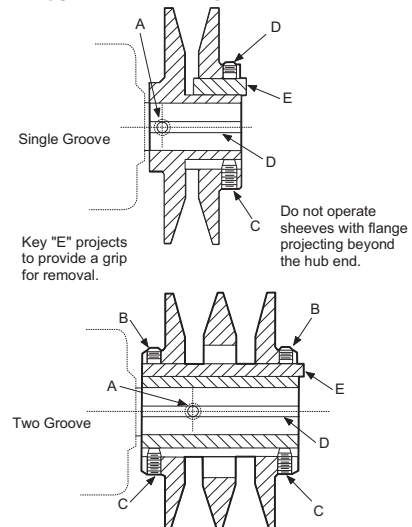
### Adjusting

1. Loosen setscrews **B** and **C** in moving parts of sheave and pull out external key **E**. (This key projects a small amount to provide a grip for removing.)
2. To adjust sheave pitch diameter for desired speed, open moving parts by half or full turns from closed position. **Do not open more than five full turns for A belts or six full turns for B belts.**
3. Replace external key **E** and securely tighten setscrews **B** over key and setscrews **C** into keyway in fixed half of the sheave.
4. Put on belts and adjust belt tension. **Do not force belts over grooves.** See [Fan Drive Belt Adjustment on page 62](#).
5. Make future adjustments by loosening the belt tension and increasing or decreasing the pitch diameter of the sheave

by half or full turns as required. Re-adjust belt tension before starting drive.

6. To provide the same pitch diameter, adjust both halves of the two-groove sheaves by the same number of turns from closed position.
7. Verify that all keys are in place and that all setscrews are tight before starting drive. Check setscrews and belt tension after 24 hours service.

Figure 101: VP Type Sheave Adjustment



## LVP Variable Speed Sheaves

### Mounting

1. Slide sheave on motor shaft so that the side of the sheave with setscrew **A** is next to the motor when setscrew **A** is in the hub or barrel of the sheave.
2. When setscrew **A** is at an angle in the center flange **B**, mount it away from the motor so that the outer locking ring and flange can be removed to get to the setscrew.
3. To remove the flange and locking ring:
  - a. Loosen setscrews **D**.
  - b. Loosen but **do not remove** capscrews **E**.
  - c. Remove key **F**.
  - d. Rotate the flange counterclockwise until it disengages the threads on the sheave barrel.

**NOTE:** This key projects a small amount to provide a grip for removing.

4. Verify that the driving and driven sheaves are in alignment and the shafts are parallel. When aligning two-groove sheaves, allow room between the sheave and motor to access capscrews **E**.
5. Insert key **C** between the sheave and the shaft and tighten setscrew **A** securely.
6. If flange and locking ring have been removed, when

replacing them make sure that the inner and outer flanges are open from the closed position by the same amount as the other flange. Determine this by accurately measuring the top width of the grooves.

7. Insert key **F**.
8. Tighten setscrews **D** and capscrews **E**.
9. Put on belts and adjust belt tension. **Do not force belts over grooves.** See [Fan Drive Belt Adjustment on page 62](#).
10. Before starting the drive, ensure that all keys are in place and all setscrews and all capscrews are tight. Check and retighten all screws and retention belts after approximately 24 hours of service.

### Adjusting

1. Slack off belt tension if belts have been installed.
2. Loosen setscrews **D**.
3. Loosen but do not remove capscrews **E**.
4. Remove key **F**.

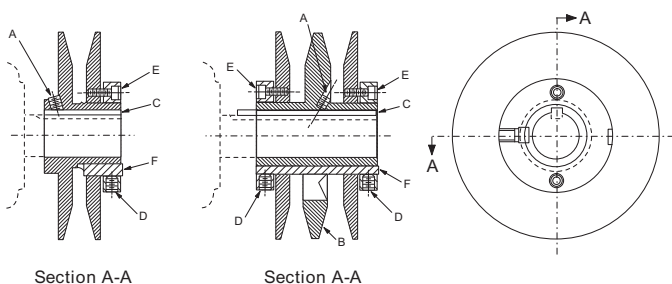
**NOTE:** This key projects a small amount to provide a grip for removing.

5. Adjust pitch diameter by opening or closing the movable flanges by half or full turns.

**NOTE:** Two-groove sheaves are supplied with both grooves set at the same pitch diameter.

6. To provide the same pitch diameter for satisfactory operation, move both movable flanges the same number of turns. Do not open sheaves more than five turns for **A** belts or six turns for **B** belts.
7. Replace key **F**.
8. Tighten setscrews **D** and capscrews **E**.
9. If belts have been installed, readjust belt tension. If belts have not been installed, install them and adjust belt tension. **Do not force belts over grooves.** See [Fan Drive Belt Adjustment on page 62](#).
10. Before starting the drive, ensure that all keys are in place and all setscrews and all capscrews are tight. Check and retighten all screws and retention belts after approximately 24 hours of operation.

**Figure 102: LVP Type Sheave Adjustment**



## MVP Variable Speed Sheaves

### Mounting

1. Verify both driving and driven sheaves are in alignment and the shafts are parallel. The centerline of the driving sheave must be in line with the centerline of the driven sheave. See [Figure 103](#).
2. Verify that all setscrews are torqued to the values shown in [Table 46](#) before starting drive. Check setscrew torque and belt tension after 24 hours of service.

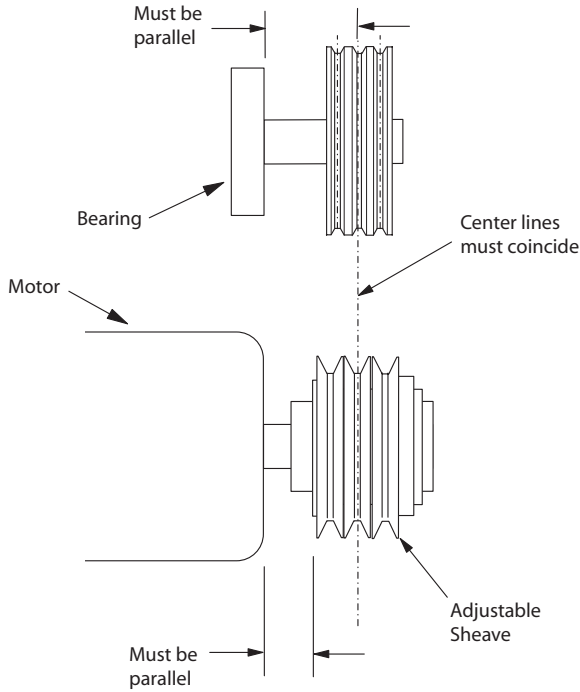
### Adjusting

1. Adjust motor base forward to release belt tension. Remove the belts for easier adjustment.
2. Loosen, but do not remove both of the locking setscrews **A** in the outer locking ring by using a hex key or torque wrench with a hex bit.
3. Adjust sheave to desired pitch diameter by turning the outer locking ring. Use a spanner wrench or drift inserted into the three holes that are located 120° apart on the ring.
4. Any pitch diameter can be obtained within the sheave range. One complete turn of the outer locking ring changes the pitch diameter 0.233".
5. Do not open sheaves more than the following:
  - a. Do not open **B** sheaves more than 4, 3/4 turns for the **A** belts or 6 turns for the **B** belts.
  - b. Do not open **C** sheaves more than 9, 1/2 turns.
  - c. Do not open **5V** sheaves more than 6 turns.
  - d. Do not open **8V** sheaves more than 8 turns.
6. Tighten BOTH locking screws **A** in the outer locking ring before operating the drive. Use a torque wrench and tighten to the value shown in [Table 46](#).
7. Replace belts and adjust the motor base to tension the belts properly. See [Fan Drive Belt Adjustment on page 62](#).
8. Do not loosen any screws other than the two locking screws **A** in the outer locking ring when adjusting the sheave pitch. Do not operate the drive until the locking screws have been set to the torque specifications.

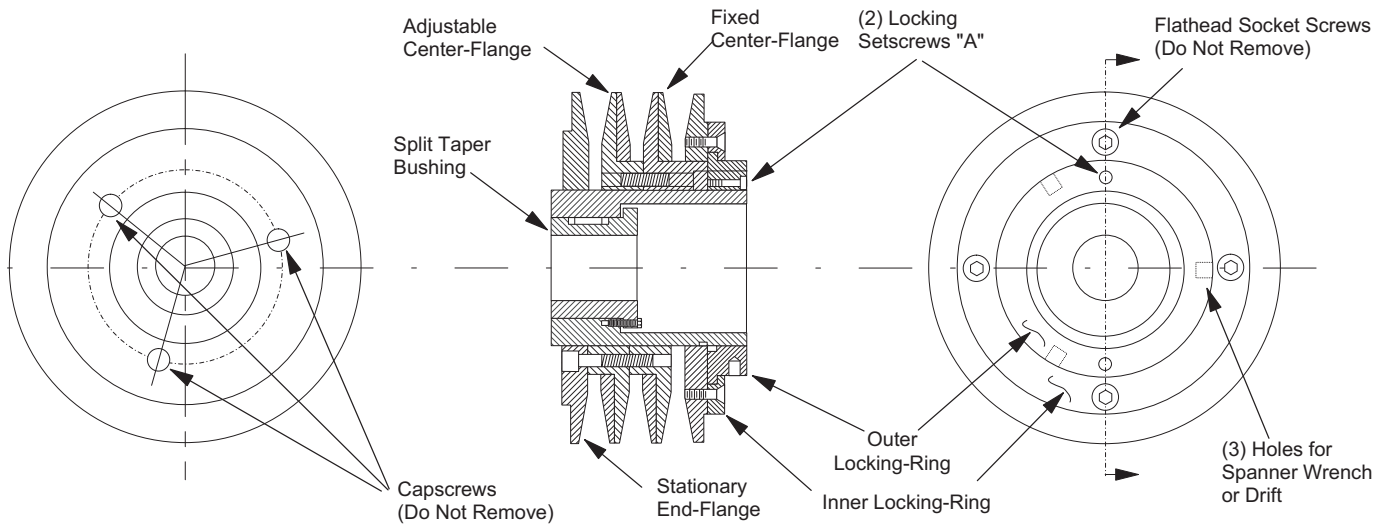
**Table 46: Screw Torque Values**

Nominal screw size (dia—thds/in)	Socket-head cap screws		Flat-head socket screws	Hollow-head set screws only			
	Seating torque (in-lbs)	Seating torque (in-lbs)		Lengths equal or greater than dia.		For lengths (L) less than dia.	
			Seating torque (in-lbs)	Seating torque (in-lbs)	Seating torque (in-lbs)	Seating torque (in-lbs)	Length (L) (in-lbs)
1/4–20NC	150	12.5	100	87	7.3	3/16	50
5/16–11NC	305	25.4	200	165	13.8	1/4	90
3/8–16NC	545	45.4	350	290	24.2	1/4, 5/16	150, 250
1/2–13NC	1300	108.3	N/A	620	51.7	N/A	N/A
5/8–11NC	N/A	N/A	N/A	1225	102.1	N/A	N/A

**Figure 103: Sheave Alignment**



**Figure 104: Adjustable Sheave Components**



## Fan Drive Belt Adjustment

**⚠ WARNING**

Moving belt and fan can cause severe personal injury or death.

During installation and filter maintenance:

- Verify that the belt and fan guards on plenum fan units are always in place.
- Lock and tag out fans to prevent accidental start up.
- Do not enter the filter compartment until the fan is completely stopped.
- Use approved equipment for reaching filters located above normal reach. Do not step on filter frames or unit components.
- Floor surfaces must be dry and free of oil or grease.

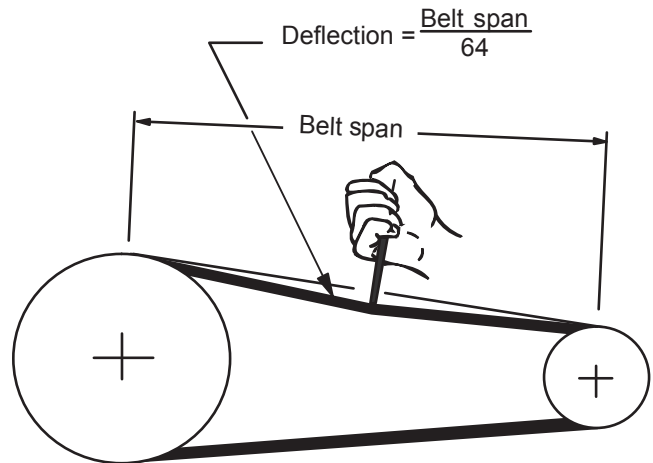
### General Rules of Tensioning

1. The ideal tension is the lowest tension at which the belt does not slip under peak load conditions.
2. Check tension frequently during the first 24 to 48 hours of operation.
3. Over tensioning shortens belt and bearing life.
4. Keep belts free from foreign material that can cause slippage.
5. Inspect V-drive on a periodic basis. Adjust tension if the belt is slipping. Do not apply belt dressing. This can damage the belt and cause early failure.

### Tension Measurement Procedure

1. Measure the belt span. See [Figure 105](#).
2. Place belt tension checker squarely on one belt at the center of the belt span. Apply force to the checker, perpendicular to the belt span, until the belt deflection equals belt span distance divided by 64. Determine the force applied while in this position.
3. Compare this force to the values in [Table 47](#).

**Figure 105: Drive Belt Adjustment**



**Table 47: Belt Deflection Force (per Browning Specifications)**

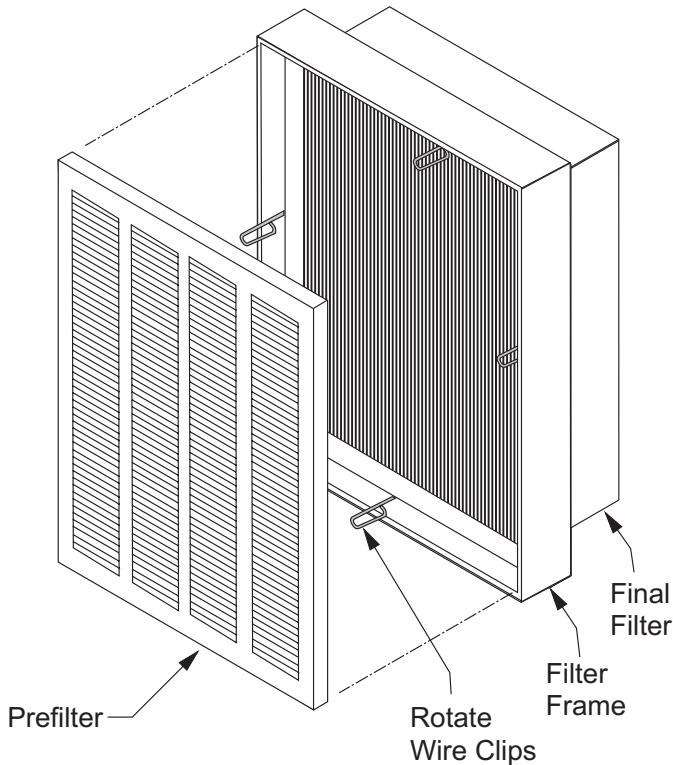
Cross section	Small sheave diameter (in)	Number of belts (deflection force lbs)					
		1		2		3 +	
		min	max	min	max	min	max
A, AX	0.0 to 3.5	3.0	5.0	2.5	4.0	2.0	3.5
	3.6 to 4.4	3.5	5.0	3.0	4.5	2.0	4.0
	4.5 +	4.0	5.5	3.0	5.0	2.5	4.5
B, BX	0.0 to 5.4	5.5	8.0	4.5	7.0	3.5	5.5
	5.5 to 7.6	5.5	8.5	4.5	7.5	3.5	5.5
	7.7 +	6.5	9.0	5.0	8.0	4.0	6.5
5V, 5VX	0.0 to 8.5	7.0	11.0	5.5	9.0	4.0	7.0
	8.6 to 12.0	8.5	13.0	6.5	10.5	5.0	8.0
	12.1 +	10.0	15.0	7.5	11.5	5.5	9.0

## Front Load Filter Option

Front loaded filter options require that the filters be removed and replaced from inside the unit.

To remove filters, rotate the wire clips. This releases both the prefilter and the final filter. When installing clean filters, check to verify the filters are fully seated in the frame (Figure 106).

Figure 106: Frame and Filters with Holding Clips



## Filter Gauges

Filter gauges indicate pressure drop for installed filters. If prefilters are present, the gauge will indicate the pressure drop for both pre-and final filters

Table 48 shows the typical filter pressure drop for clean filters at rated air flow. The tables also show a final pressure drop for front loaded filters.

Where a single filter gauge is used, the prefilters can be removed to check the pressure drop of the final filters.

Figure 107: Filter Gauge

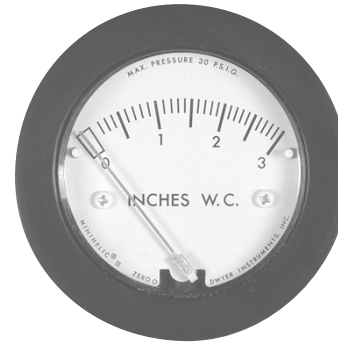


Table 48: Filter Pressure Drops

Bag filters—DriPak 2000				
Efficiency	45%	65%	85%	95%
Rated velocity (fpm)	625	500	500	500
Initial pressure drop	0.20–0.26	0.21–0.30	0.34–0.48	0.50–0.70
Initial pressure drop	1.0	1.0	1.0	1.0
Cartridge filters—Varicel II MH, 4.25" deep				
Efficiency	65%	85%	95%	
Rated velocity (fpm)	500	500	500	
Initial pressure drop	0.43	0.61	0.70	
Final pressure drop	1.5	1.5	1.5	
Cartridge filters—Varicel SH, 12" deep				
Efficiency	70%			
Rated velocity (fpm)	500			
Initial pressure drop	0.39			
Final pressure drop	1.2			
Pleated panel filters				
Type	Perfect pleat	AMAir 300 4"		
Efficiency	30%	30%		
Rated Velocity (fpm)	500	625		
Initial Pressure Drop	0.36	0.36		
Final Pressure Drop	1.0	1.0		
5700 filters				
Efficiency	N/A			
Rated velocity (fpm)	500			
Initial pressure drop	0.25			
Final pressure drop	1.0			
Pleated 62 Plus filters				
Size	2"	4"		
Efficiency	70%	70%		
Initial pressure drop	0.42	0.37		
Final pressure drop	1.0	1.0		

## Coils

1. The coil must be clean to obtain maximum performance. Check once a year under normal operating conditions and, if dirty, brush or vacuum clean. Use a chemical coil cleaner on multiple row coils. Read and follow the chemical cleaner's instructions as some cleaners may contain harsh chemicals. Take care not to damage fins while cleaning.
2. Drain pans in any air conditioning unit may have some moisture. Algae, etc., can grow due to airborne spores and bacteria. Periodic cleaning is necessary to prevent this buildup from plugging the drain and causing the drain pan to overflow. Also, keep the drain pans clean to prevent the spread of disease. Cleaning should be performed by qualified personnel.
3. Dirt and lint can clog the condensate drain, especially with dirty filters. Inspect twice a year to help avoid overflow.

## Winterizing Water Coils

### WARNING

**Mold can cause personal injury.** Clean drain pan regularly so mold does not develop.

Coils can freeze due to air stratification or failure of outdoor air dampers and/or preheat controls. Do not depend on routine draining of water cooling coils for winter shutdown as insurance against freeze-up. Severe coil damage can result. Drain all coils as thoroughly as possible and then treat in the following manner.

- Fill each coil independently with an antifreeze solution using a small circulating pump and again thoroughly drain.
- Check freezing point of antifreeze before proceeding to next coil. Due to a small amount of water always remaining in each coil, there is a diluting effect. The small amount of antifreeze solution remaining in the coil must always be concentrated enough to prevent freeze-up.

**NOTE:** Carefully read instructions for mixing antifreeze solution used. Some products have a higher freezing point in their natural state when mixed with water. Daikin Applied is not responsible for the freezing of coils.

## Removing and Replacing Components

### WARNING

**Before removing component, lock out and tag out all power to the unit.** Fans and belts can cause severe personal injury or death.

See on page 12 for instructions on removing panels and opening fan access doors to remove or replace components.

## Removing the Fan Section

The fan shaft, motor, and any drive components can be removed and replaced through the access door opening. If required, the side panel can be removed for additional access.

If fan replacement is required, the entire fan assembly can be pulled out the side of the cabinet for housed fan assemblies. The fan assembly includes the fan housing, the bearing support, and the fan base.

## Removing the Fan Assembly

1. Remove the side panels and any intermediate supports (follow instructions for side panel removal).
2. Once the panels and any intermediate supports are removed, disconnect the neoprene bulk head seal that is attached to the fan discharge.
3. Remove the four discharge angles that hold the neoprene canvas in place around the discharge opening.
4. Disconnect the fan sled from each of the corner mounts and pull the entire assembly out the side of the unit.
5. After the fan sled is out, loosen the fan bearings and pull out the shaft.
6. Disconnect the fan housing from the fan sled, and bearing support by removing the attaching bolts.
7. Replace the new fan, reconnect the shaft and bearings and put the fan assembly in the cabinet.
8. Replace panels and fasteners.

## Removing the Fan Section

For plenum fan assemblies, the entire fan cabinet may need to be removed to replace the entire fan assembly depending on the length of the fan section. In some cases, the fan section is not long enough for the assembly to fit out the side of the cabinet. For those cases where it will fit, follow the above steps except the neoprene seal is a D-gasket on the inlet side that needs to be removed for plenum fans. Otherwise, the entire fan cabinet must be removed from the other sections and then the fan assembly can be removed out the discharge side of the cabinet.

## Removing and Replacing the Coil

### Removing Single Coils

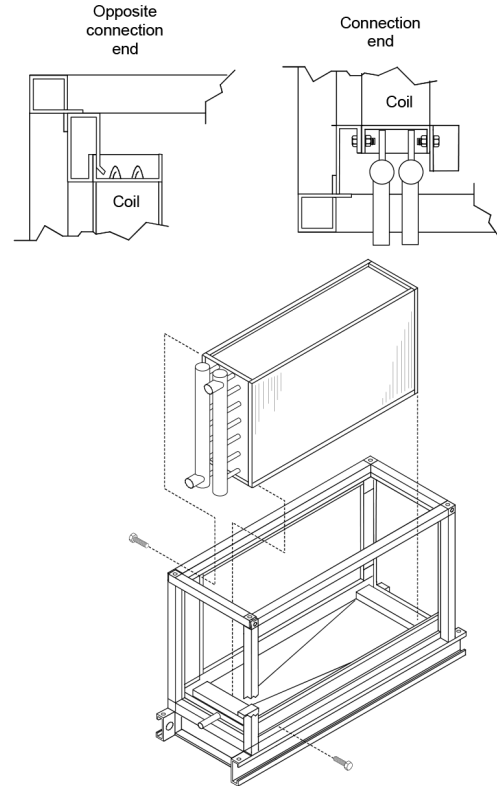
**NOTE:** Single coils are bolted to the unit on the connection end. The connection end is held in place with a clamp.

1. Disconnect all piping and remove the brass plugs for the vents and drains located in the connections.
2. Remove all screws and remove the access panel.
3. Remove the screws holding the coil in place.
4. Lift and pull the coil out the side.

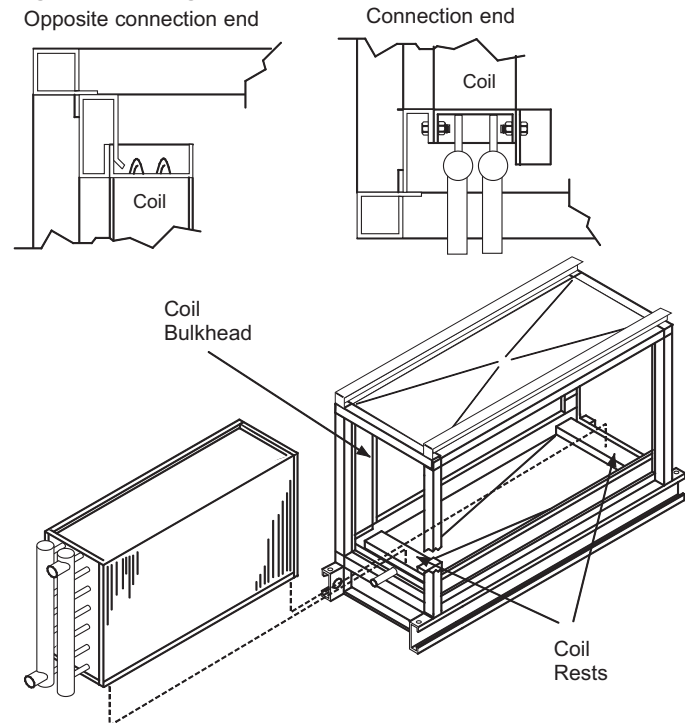
### Installing Single Coils

1. Slide the coil through the opening in the coil section onto the bottom coil rests.
2. To prevent any air bypass around the coil, place coils up against the coil bulkheads. See [Figure 108](#).
3. Once the coil is in place, fasten the coil to the section.
4. Caulk the seams between the coil casings and bulkheads.
5. If this is an additional coil being installed and not a replacement, locate the coil supply and return connections dimensionally. Carefully drill holes in the end panels of the unit.
6. Remove the brass plugs for the vents and drains on the connections.
7. Slip the panel over the connections.
8. Replace the brass plugs and panel fasteners.

**Figure 108: Single Coil Top Installation/Removal**



**Figure 109: Single Coil Side Installation/Removal**



### **Removing Stacked Coils**

**NOTE:** Top and bottom stacked coils are held together with steel plate and screws on one side and drain trough and screws on the other side. Remove the plate and trough before removing the coils. The coils cannot be removed attached together.

1. Disconnect all piping and remove the brass plugs for the vents and drains located in the connections.
2. Remove all screws and remove the access panel.
3. Remove the bolts holding the coil in place and then lift and pull out the coil from the side.
4. Remove the steel plate and the drain trough that holds the coils together.
5. Remove the bolts on both ends of the top coil holding it in place and then lift and slide the coil out.
6. Remove the bolts on both ends of the bottom coil holding it in place and then lift and slide the coil out.

### **Installing Stacked Coils**

**NOTE:** Ensure the drain pan is fully sealed before installing the filler panel and coil panel. If gaps or damage is seen, refer to the procedure outlined in [See Field-Installed Coils on page 23](#).



1. Slide the bottom coil through the opening in the coil section onto the bottom coil rests.
2. Place the coil up against the coil bulkheads to prevent any air bypass around the coil.
3. Once the coil is in place, bolt the coil to the section.
4. Caulk the mounting surface of the steel plate and install the plate on the coils.
5. Caulk the mounting surface of the drain trough and install the drain trough on the coils.
6. Caulk the seams between the coil casings and blockoffs.
7. Connect all piping and install the brass plugs for the vents and drains located in the connections.
8. Install the access panel.


### **Removing and Installing Staggered Coils**


Staggered coils have two banks of coils positioned a few inches apart in the direction of airflow. Both coils are secured to the unit on the connection and opposite connection end of the unit.

1. Disconnect all piping and remove the brass plugs for the vents and drains located in the connections.
2. To access bolts holding the coils in place, remove the panels on both the connection and opposite connection end of the coil section.
3. Each coil is held in place with bolts located in the corners of the coil side plates. Remove the bolts and then lift and pull the coil out the side.
4. The bottom coil is fastened to the air block off plate. Remove the screws attaching this plate to the coil.
5. Once the fasteners holding the coil in place are removed, pull out the coil from either side of the unit.
6. Install the coils in reverse order of removal.


## A2L Refrigerant Guidelines (If Applicable)

 <b>WARNING</b>	
	<p>This unit contains either R-32 or R-454b, a class A2L refrigerant that is flammable. This unit should only be installed, serviced, repaired, and disposed of by qualified personnel licensed or certified in their jurisdiction to work with the specific A2L refrigerant. Installation and maintenance must be done in accordance with this manual. Improper handling of this equipment can cause personal injury or equipment damage.</p>
<p>Be aware that R-32 and R454b refrigerant may not contain an odor. Place in a well ventilated area to prevent accumulation of refrigerant. Excessive refrigerant leaks, in the event of an accident in a closed ambient space, can lead to oxygen deficiency.</p> <p>Do not pierce or burn this unit.</p> <p>Never use an open flame during service or repair. Never store in a room with continuously operating ignition sources (for example: open flames, an operating gas appliance, or and operating electric heater), where there is ignitable dust suspension in the air, or where volatile flammables such as thinner or gasoline are handled.</p> <p>Skyline units may be shipped as partial units and should only be connected to appliances that are suitable for the air handling unit's designated refrigerant.</p> <p>Only use pipes, nuts, and tools intended for exclusive use with the unit's designated A2L refrigerant in compliance with national codes (ASHRAE15 or IRC).</p> <p>Do not mix air or gas other than the unit's designated A2L refrigerant in the refrigerant system.</p> <p>Do not use means to accelerate the defrosting process or to clean, other than those recommended by the manufacturer.</p>	

 <b>DANGER</b>	
<p>LOCKOUT/TAGOUT all power sources prior to servicing the unit or opening any panels or doors. This Appliance is equipped with a Refrigerant Leak Detection system and the system components such as supply fans may begin operation unexpectedly and without warning.</p>	

 <b>WARNING</b>	
<p>Unit must be powered at all times, except when servicing. The appliance is designed with leakage mitigation, which requires continuous airflow in the event a refrigerant leak is detected. This is required to ensure dilution and prevent stagnation of any leaked refrigerant. Always ensure the supply fans are able to operate freely. Always maintain proper airflow and do not allow filters, air inlets, or air outlets to become blocked.</p>	

 <b>WARNING</b>	
<p>In the unlikely event that a refrigerant leak occurs, all dampers must be driven to remain fully open to provide ventilation.</p>	

 <b>WARNING</b>	
<p>Units using A2L refrigerants connected to one or more rooms must be ducted directly to the space. Open areas, such as false ceilings cannot be used as a return air duct.</p>	

### Safety Considerations

This unit is equipped with an A2L (R32 or R454b) refrigerant and a Refrigerant Leak Detection and Mitigation system. In the unlikely event of a refrigerant leak, the unit must be instructed to take mitigating actions such as activation of diluting airflow and/or disabling certain unit functions. For full details on the mitigation modes and sequence of operation please refer to the literature for the A2L mitigation control board. For connection to customer control systems or a Building Management System a field connection is provided with the A2L controls. Please refer to the unit specific electrical schematic for the connection details.

Maintaining and servicing A2L refrigerants should only be performed as recommended by this manual and by personnel licensed or certified in their jurisdiction to handle A2L refrigerants under a controlled procedure. Dismantling the unit and treatment of the refrigerant, oil, and additional parts must be done in accordance with the relevant local, state, and national regulations.

Only use tools meant for use on the unit's designated A2L refrigerant, such as a gauge manifold, charge hose, gas leak detector, reverse flow check valve, refrigerant charge base, vacuum gauge, or refrigerant recovery equipment.

### Field Installation Considerations

All Field installed or modified refrigerant containing pipe-work including piping material, pipe routing, and installation shall include protection from physical damage in operation and service, and be in compliance with national and local codes and standards, such as ASHRAE 15, ASHRAE 15.2, IAPMO Uniform Mechanical Code, ICC International Mechanical Code, or CSA B52. All field joints shall be accessible for inspection prior to being covered or enclosed.

After completion of any field installed piping for split systems the pipework shall be pressure tested with an inert gas and vacuum tested prior to being charged with refrigerant per the procedure below.

The minimum test pressure for the low side of the system shall be the low side design pressure and the minimum test pressure for the high side of the system shall be the high side design pressure, unless the high side of the system, cannot be isolated from the low side of the system in which case the entire system shall be pressure tested to the low side design pressure.

**NOTE:** For information on field control wiring requirements when electric or gas heat ignition sources are present, consult [See Electric and Gas Heat on page 37](#).

## Minimum Room Area

### WARNING

Failure to maintain the required Minimum Room Area for leaked refrigerant dilution may result in property damage, serious personal injury, or death.

In the unlikely event of a refrigerant leak, the leak detection system must activate the supply fans to a preset speed that corresponds to an airflow that is always greater than the minimum required airflow rate. This airflow is required to dilute any leaked refrigerant and prevent stagnation. The actual unit airflow may be much higher depending on configuration. The minimum airflow rate is based on circuit charge quantity and is detailed in [Figure 112 on page 71](#) and [Figure 113 on page 72](#).

This unit contains an A2L refrigerant (R-32 or R-454b). The served indoor space must be larger than or equal to the Minimum Room Area as shown starting on [page 69](#). In the unlikely event of a refrigerant leak this room area must meet this requirement to ensure dilution and prevent stagnation of any leaked refrigerant.

The Refrigerant Charge of each unit should be determined and used to confirm the Minimum Room Area prior to installation. For guidance on refrigerant charge calculation, see “[Minimum Room Area Calculation \(A2L Refrigerants\)](#)” on [page 24](#).

When the appliance is connected to an unventilated space the following rules shall apply to determine if connected spaces can be used in the Minimum Room Area calculation. The room area shall be defined as the room area enclosed by the projection to the floor of the walls, partitions and doors of the space in which the unit serves. Spaces connected by only drop ceilings, ductwork, or similar connections shall not be considered a single space. Rooms on the same floor and connected by an open passageway between the spaces can be considered a single room when determining compliance to Minimum Room Area, if the passageway complies with all of the following:

- It is a permanent opening.
- It extends to the floor.
- It is intended for people to walk through.

The area of the adjacent rooms, on the same floor, connected by a permanent opening in the walls and/or doors between occupied spaces, including gaps between the wall and the floor, can be considered a single room when determining compliance to the Minimum Room Area, provided all of the following are met:

- The minimum opening area connecting the spaces/rooms shall not be less than 0.0123 m<sup>2</sup>.
- The area of any openings above 300 mm from the floor shall not be considered part of the minimum opening area.
- At least 50 % of the minimum opening area shall be below 200 mm from the floor.
- Openings are permanent openings which cannot be closed.
- For openings extending to the floor the height shall not be less than 20 mm above the surface of the floor covering.
- A second higher opening shall be provided. The total size of the second opening shall not be less than 50% of the minimum opening area and shall be at least 1.5 m above the floor.

**NOTE:** The requirement for the second opening can be met by drop ceilings, ventilation ducts, or similar arrangements that provide an airflow path between the connected rooms.

## Altitude Considerations for Minimum Room Area

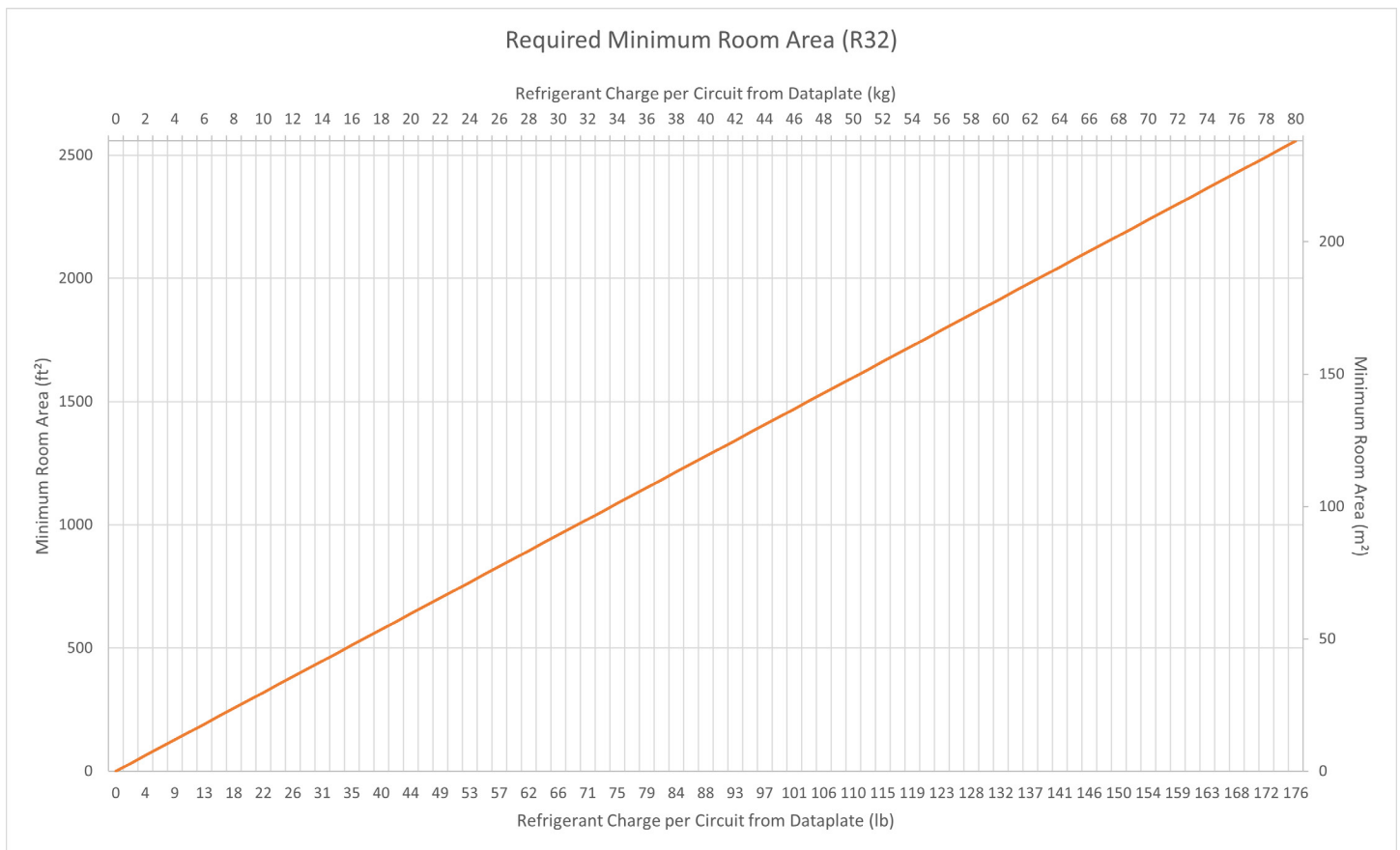
When the unit is installed at altitude above sea level the minimum room area must be adjusted by the multiplier shown in [Table 49 on page 69](#). This will increase the required minimum room area of the served space.

If the actual room area served by the appliance is not large enough to meet the Minimum Room Area additional measures such as mechanical ventilation of the space may need to be employed. Please contact Daikin Applied for additional information.

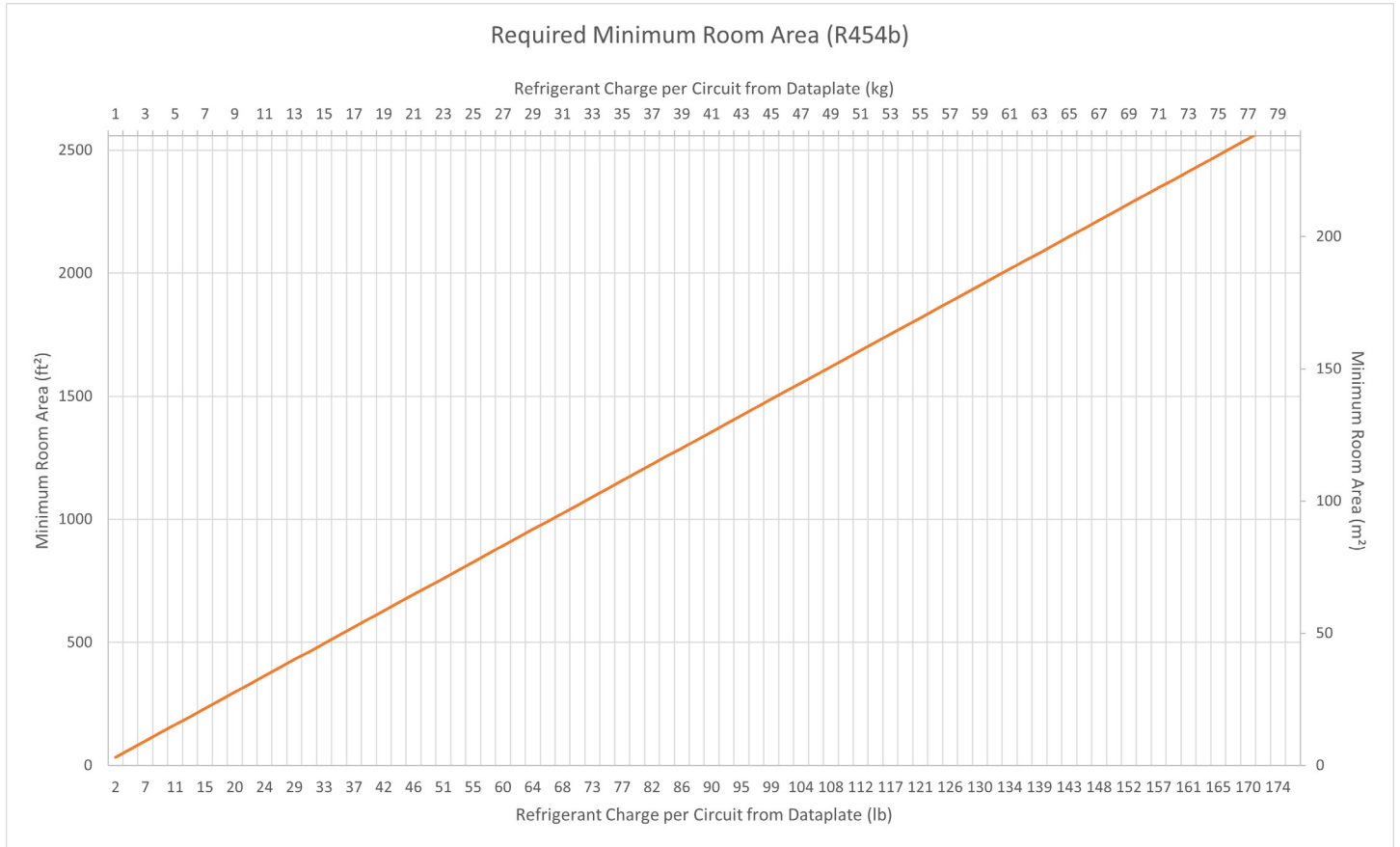
**Table 49: Minimum Room Area Multipliers by Altitude**

Altitude (Meters)	Minimum Room Area Multiplier
0	1
305	1.047
500	1.078
750	1.117
1000	1.156
1250	1.195
1500	1.234
1750	1.273
2000	1.312
2250	1.351
2500	1.39
2750	1.429
3000	1.468
3250	1.507
3500	1.546

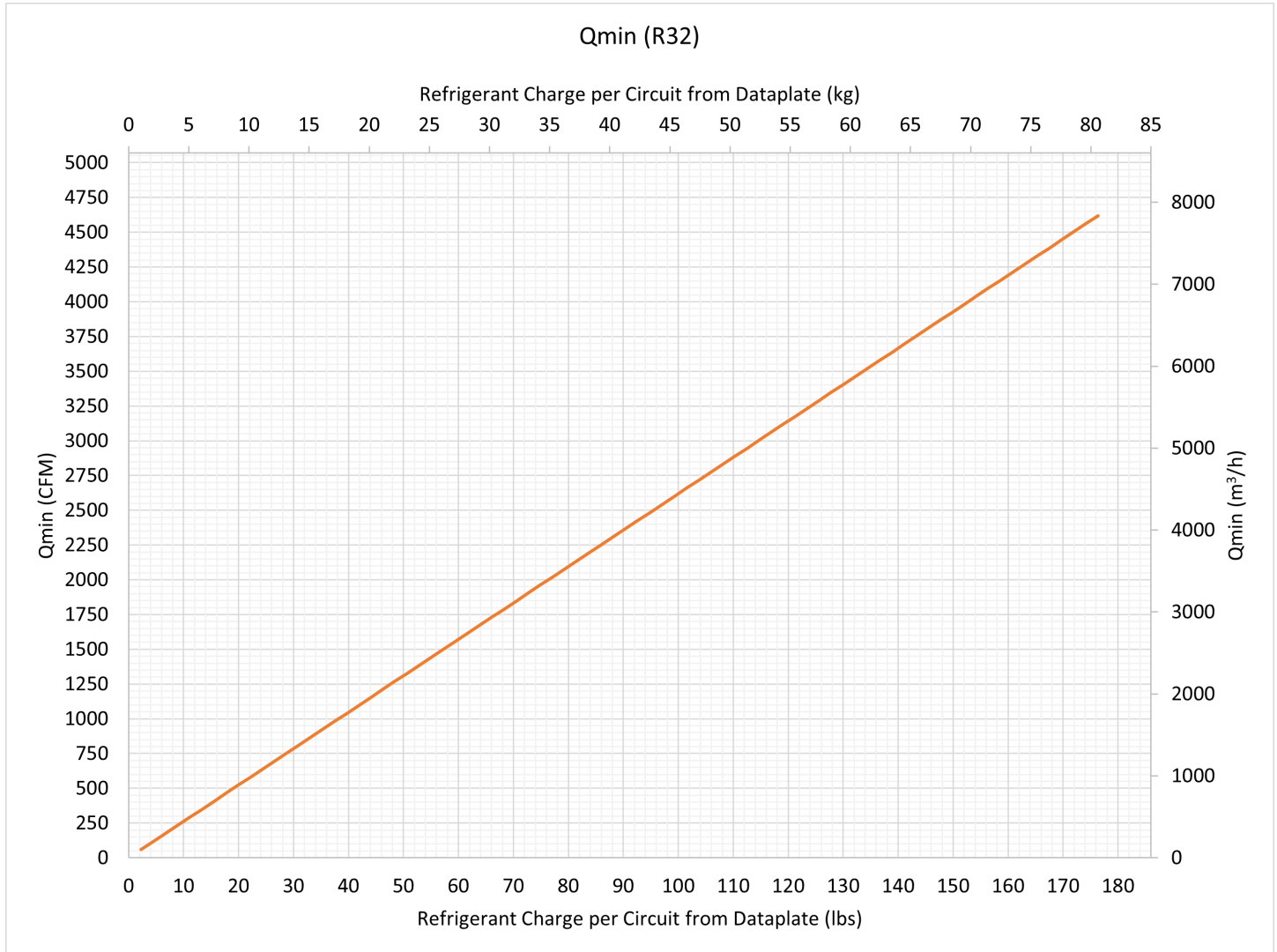
**Figure 110: R32 Refrigerant - Required Minimum Room Area**



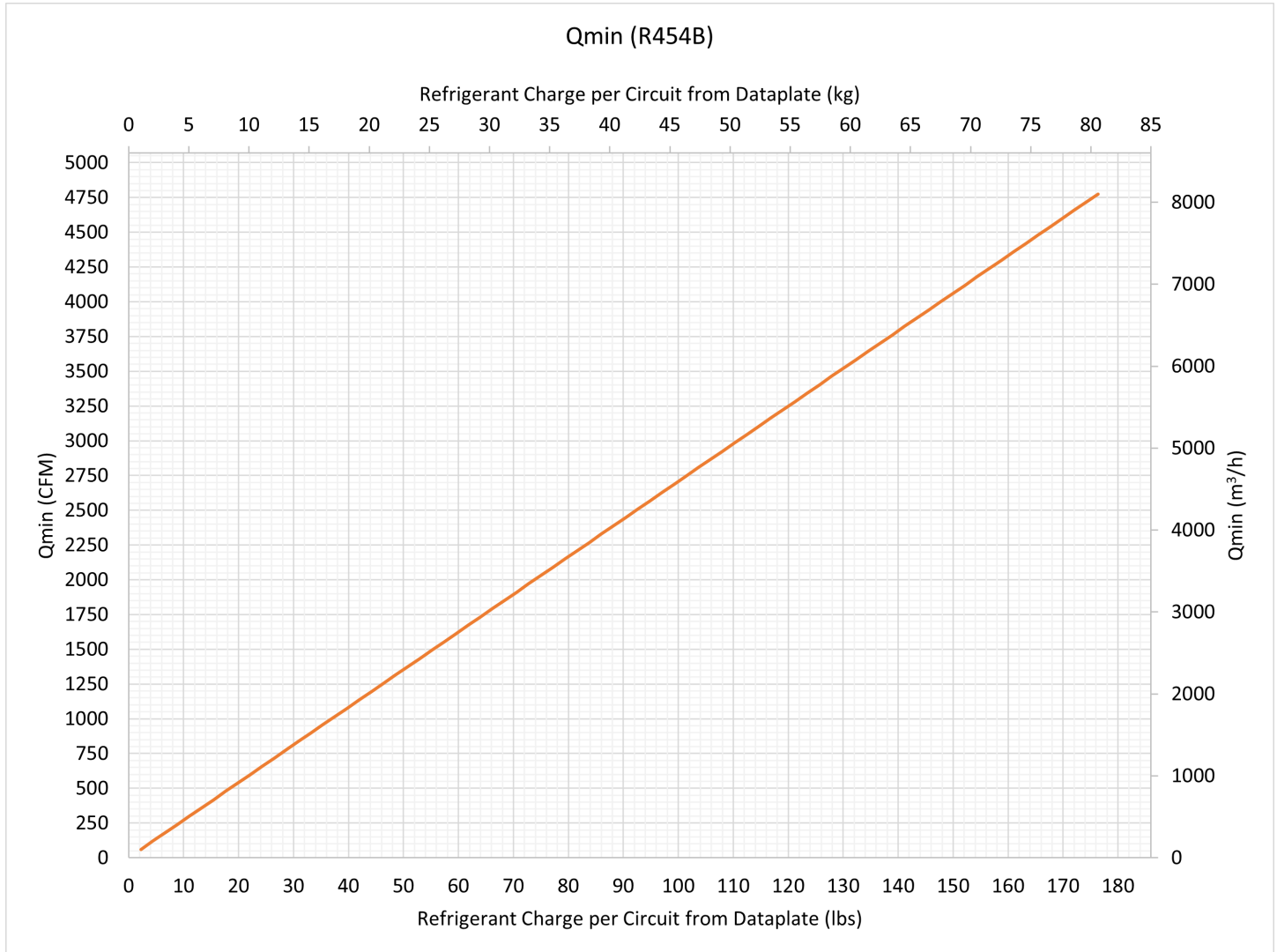
**Figure 111: R454b Refrigerant - Required Minimum Room Area**



**Figure 112: R32 Refrigerant - Minimum Circulation of Airflow (Qmin)**



**Figure 113: R454b Refrigerant - Minimum Circulation of Airflow (Qmin)**



## Leak Mitigation System and Sensors

For Additional Instructions on how to operate the Leak Mitigation System, refer to IM 1365.

### **WARNING**

This equipment is equipped with a Refrigerant Leak Detection System. Only components and Refrigerant Detection Sensors specified by Daikin Applied may be used for replacement and maintenance.

### **WARNING**

Always ensure the Refrigerant Detection Sensors installed in the equipment are free of debris and the inlet is not blocked. If replacing a Refrigerant Detection Sensor always install in the identical orientation as the original sensor.

**Figure 114: Sample Refrigerant Detection Sensor**



**NOTE:** Identify the sensor inlet marked “Do Not Block Inlet”.

### **WARNING**

Auxiliary devices which may be a Potential Ignition Source shall not be installed in the duct work. Examples of such Potential Ignition Sources are hot surfaces with a temperature exceeding 700°C and electric switching devices.

### **WARNING**

The unit must be stored and/or located to prevent mechanical damage of the refrigeration system. Do not store the unit near sources of open flame, electrical switching devices, or hot surfaces above 700°C. If the unit is stored indoors the storage area should be larger than the Minimum Room Area specified in this manual. The storage space should be well ventilated and not allow for the stagnation of leaked refrigerant. Failure to do so may result in a fire or explosion hazard.

### **WARNING**

Only auxiliary devices approved by Daikin Applied or declared suitable for installation with the unit's designated A2L refrigerant shall be installed in the connecting ductwork.

## Performing Service

### **Remove Ignition Sources**

Always perform a safety check of the area to ensure the risk of ignition is minimized before servicing the unit.

### **Personnel Awareness**

Inform maintenance staff and others working in the local area of the nature of work being carried out. Only personnel attending to the refrigerant system should be present.

### **Check for Presence of Airborne Refrigerant**

Check the area with an appropriate refrigerant detector prior to and during work to ensure all personnel are aware of potentially toxic or flammable gases in the air. Ensure that the leak detection equipment being used is suitable for use with all applicable refrigerants; i.e., non-sparking, adequately sealed or intrinsically safe.

### **Presence of fire extinguisher**

If any hot work is to be conducted on the refrigerating equipment or any associated parts, appropriate fire extinguishing equipment should be available to hand. Have a dry powder or CO2 fire extinguisher adjacent to the charging area.

### **No Ignition Sources**

No person carrying out work in relation to a REFRIGERATING SYSTEM which involves exposing any pipe work shall use any sources of ignition in such a manner that it may lead to the risk of fire or explosion. All possible ignition sources, including cigarette smoking, should be kept sufficiently far away from the site of installation, repairing, removing and disposal, during which refrigerant can possibly be released to the surrounding space. Prior to work taking place, the area around the equipment is to be surveyed to make sure that there are no flammable hazards or ignition risks. “No Smoking” signs shall be displayed.

### **Ventilated area**

Ensure that the area is in the open or that it is adequately ventilated before breaking into the system or conducting any hot work. A degree of ventilation shall continue during the period that the work is carried out.

### **Checks to the refrigerating equipment**

Where electrical components are being changed, they shall be fit for the purpose and to the correct specification. At all times the manufacturer's maintenance and service guidelines shall be followed. If in doubt, consult the manufacturer's technical department for assistance.

The following checks shall be applied to installations using FLAMMABLE REFRIGERANTS:

- The actual REFRIGERANT CHARGE is in accordance with the room size within which the refrigerant containing parts are installed.
- The ventilation machinery and outlets are operating adequately and are not obstructed.

- If an indirect refrigerating circuit is being used, the secondary circuit shall be checked for the presence of refrigerant.
- Marking to the equipment continues to be visible and legible. Markings that are illegible shall be corrected.
- Refrigerating pipe or components are installed in a position where they are unlikely to be exposed to any substance which may corrode refrigerant containing components, unless the components are constructed of materials which are inherently resistant to being corroded or are suitably protected against being so corroded.

### Checks to electrical devices

Repair and maintenance to electrical components shall include initial safety checks and component inspection procedures. If a fault exists that could compromise safety, then no electrical supply shall be connected to the circuit until it is satisfactorily dealt with. If the fault cannot be corrected immediately but it is necessary to continue operation, an adequate temporary solution shall be used. This shall be reported to the owner of the equipment so all parties are advised.

Initial safety checks shall include:

- that capacitors are discharged: this shall be done in a safe manner to avoid possibility of sparking;
- that no live electrical components and wiring are exposed while charging, recovering or purging the system;
- that there is continuity of earth bonding.

### Sealed and intrinsically safe components

- All sealed electrical components shall be replaced.
- All intrinsically safe components must be replaced.

### Cabling

- Check that cabling will not be subject to wear, corrosion, excessive pressure, vibration, sharp edges or any other adverse environmental effects. The check shall also take into account the effects of aging or continual vibration from sources such as compressors or fans.

### Detection of flammable refrigerants

Under no circumstances shall potential sources of ignition be used in the searching for or detection of refrigerant leaks. A halide torch (or any other detector using a naked flame) shall not be used.

The following leak detection methods are deemed acceptable for all refrigerant systems:

- Electronic leak detectors may be used to detect refrigerant leaks but, in the case of FLAMMABLE REFRIGERANTS, the sensitivity may not be adequate, or may need re-calibration. (Detection equipment shall be calibrated in a refrigerant-free area.) Ensure that the detector is not a potential source of ignition and is suitable for the refrigerant used. Leak detection equipment shall be set at a percentage of the LFL of the refrigerant and shall be calibrated to the refrigerant employed, and the appropriate percentage of gas (25 % maximum) is confirmed.

- Leak detection fluids are also suitable for use with most refrigerants but the use of detergents containing chlorine shall be avoided as the chlorine may react with the refrigerant and corrode the copper pipe-work.

**NOTE:** Examples of leak detection fluids are:

- bubble method; or
- fluorescent method agents.

If a leak is suspected, all naked flames shall be removed/ extinguished.

If a leakage of refrigerant is found which requires brazing, all of the refrigerant shall be recovered from the system, or isolated (by means of shut off valves) in a part of the system remote from the leak. Removal of refrigerant shall be according to instructions above.

### Removal and evacuation

- When breaking into the refrigerant circuit to make repairs, or for any other purpose, conventional procedures shall be used. However, for flammable refrigerants it is important that best practice be followed, since flammability is a consideration.
- The following procedure shall be adhered to:
  - a. Safely remove refrigerant following local and national regulations.
  - b. Evacuate refrigerant from circuit.
  - c. Purge the circuit with inert gas.
  - d. Evacuate (optional for A2L).
  - e. Purge the inert gas (optional for A2L).
  - f. Continuously flush or purge with inert gas when using flame to open circuit.
  - g. Open the circuit by cutting or brazing.
- The refrigerant charge shall be recovered into the correct recovery cylinders. For appliances containing flammable refrigerants, the system shall be purged with oxygen-free nitrogen to render the appliance safe for flammable refrigerants. This process might need to be repeated several times.
- Compressed air or oxygen shall not be used for purging refrigerant systems.
- For appliances containing flammable refrigerants, refrigerants purging shall be achieved by breaking the vacuum in the system with oxygen-free nitrogen and continuing to fill until the working pressure is achieved, then venting to atmosphere, and finally pulling down to a vacuum.
- When the final oxygen-free nitrogen charge is used, the system shall be vented down to atmospheric pressure to enable work to take place.
- Ensure that the outlet for the vacuum pump is not close to any potential ignition sources and that ventilation is available.

## Charging procedures

### ***In addition to conventional charging procedures, the following requirements shall be followed.***

- Ensure that contamination of different refrigerants does not occur when using charging equipment.
- Hoses or lines shall be as short as possible to minimise the amount of refrigerant contained in them.
- Cylinders shall be kept in an appropriate position according to the instructions.
- Ensure that the REFRIGERATING SYSTEM is earthed prior to charging the system with refrigerant.
- Label the system when charging is complete (if not already).
- Extreme care shall be taken not to overfill the REFRIGERATING SYSTEM.
- Prior to recharging the system, it shall be pressure-tested with the appropriate purging gas. The system shall be leak-tested on completion of charging but prior to commissioning. A follow up leak test shall be carried out prior to leaving the site.

## Decommissioning

***Before carrying out this procedure, it is essential that the technician is completely familiar with the equipment and all its detail. It is recommended good practice that all refrigerants are recovered safely.***

***Prior to the task being carried out, an oil and refrigerant sample shall be taken in case analysis is required prior to re-use of recovered refrigerant.***

***It is essential that electrical power is available before the task is commenced.***

- Become familiar with the equipment and its operation.
- Isolate system electrically.
- Before attempting the procedure, ensure that mechanical handling equipment is available, if required, for handling refrigerant cylinders; all personal protective equipment is available and being used correctly; the recovery process is supervised at all times by a competent person; recovery equipment and cylinders conform to the appropriate standards.
- Pump down refrigerant system, if possible.
- If a vacuum is not possible, make a manifold so that refrigerant can be removed from various parts of the system.
- Make sure that cylinder is situated on the scales before recovery takes place.
- Start the recovery machine and operate in accordance with instructions.
- Do not overfill cylinders (no more than 80 % volume liquid charge).

- Do not exceed the maximum working pressure of the cylinder, even temporarily.
- When the cylinders have been filled correctly and the process completed, make sure that the cylinders and the equipment are removed from site promptly and all isolation valves on the equipment are closed off.
- Recovered refrigerant shall not be charged into another REFRIGERATING SYSTEM unless it has been cleaned and checked.

## Labeling

***Equipment shall be labeled stating that it has been de-commissioned and emptied of refrigerant. The label shall be dated and signed. For appliances containing FLAMMABLE REFRIGERANTS, ensure that there are labels on the equipment stating the equipment contains FLAMMABLE REFRIGERANT.***

## Recovery

- When removing refrigerant from a system, either for servicing or decommissioning, the refrigerant must be removed safely.
- When transferring refrigerant into cylinders, ensure that only appropriate refrigerant recovery cylinders are employed. Ensure that the correct number of cylinders for holding the total system charge is available. All cylinders to be used are designated for the recovered refrigerant and labeled for that refrigerant (i.e., special cylinders for the recovery of refrigerant). Cylinders shall be complete with pressure-relief valve and associated shut-off valves in good working order. Empty recovery cylinders are evacuated and, if possible, cooled before recovery occurs.
- The recovery equipment shall be in good working order with a set of instructions concerning the equipment that is at hand and shall be suitable for the recovery of all appropriate refrigerants including, when applicable, FLAMMABLE REFRIGERANTS. In addition, a set of calibrated weighing scales shall be available and in good working order. Hoses shall be complete with leak-free disconnect couplings and in good condition. Before using the recovery machine, check that it is in satisfactory working order, has been properly maintained and that any associated electrical components are sealed to prevent ignition in the event of a refrigerant release. Consult manufacturer if in doubt.
- The recovered refrigerant shall be returned to the refrigerant supplier in the correct recovery cylinder, and the relevant waste transfer note arranged. Do not mix refrigerants in recovery units and especially not in cylinders.

***If compressors or compressor oils are to be removed, ensure that they have been evacuated to an acceptable level to make certain that FLAMMABLE REFRIGERANT does not remain within the lubricant.***

**The evacuation process shall be carried out prior to returning the compressor to the suppliers. Only electric heating to the compressor body shall be employed to accelerate this process. When oil is drained from a system, it shall be carried out safely.**

## Lubrication

R-32 should only be used with manufacturer-approved oil, such as DAPHNE FW68DE. The HFC refrigerant components in R-32 will not be compatible with mineral oil or alkylbenzene lubricants. R-32 systems will be charged with the OEM recommended lubricant, ready for use with R-32.

R-454b should only be used with manufacturer-approved oil. Check with your condensing unit supplier to verify the acceptable oils to use with the refrigerant system.

## Leak Detection

NEVER use the following when attempting to detect A2L refrigerant leaks:

- A halide torch (or any other detector using a naked flame)
- Substances containing chlorine

## Pressure Testing and Refrigerant Evacuation

- Make sure that air or any matter other than A2L refrigerants do not enter the refrigeration cycle.
- If refrigerant gas leaks occur in an enclosed area, ventilate the space as soon as possible.
- A2L refrigerants should always be recovered and never released directly into the environment.
- Only use tools meant for use on the unit's designated A2L refrigerant (such as a gauge manifold, charging hose, or vacuum pump adapter).

## Commissioning

- Ensure proper connection of all piping and carry out a leak test before charging with refrigerant.
- Check safety equipment before putting into service.

## Decommissioning

ALWAYS remove refrigerant charge before decommissioning the unit.

- Ensure sufficient ventilation at the equipment location.
- Be aware that malfunction of the equipment may be caused by refrigerant loss and a refrigerant leak is possible.
- Discharge capacitors in a way that won't cause any spark.
- A2L refrigerants should always be recovered and never released directly into the environment. Take care that the drained refrigerant will not cause any danger. In doubt,

one person should guard the outlet. Take special care that drained refrigerant will not float back into the building.

## Recovery

### Recovery Cylinders

When transferring refrigerant into cylinders, ensure that only appropriate refrigerant recovery cylinders are employed. Ensure that the correct number of cylinders for holding the total system charge is available. All cylinders to be used should be designated for the recovered refrigerant and labeled for that refrigerant. Cylinders should be complete with a pressure-relief valve and associated shut-off valves in good working order. Empty recovery cylinders should be evacuated and, if possible, cooled before recovery occurs.

### Recovery Equipment

The recovery equipment should be in good working order with a set of instructions concerning the equipment that is at hand and shall be suitable for the recovery of all appropriate refrigerants including, when applicable, FLAMMABLE REFRIGERANTS. In addition, a set of calibrated weighing scales shall be available and in good working order. Hoses shall be complete with leak-free disconnect couplings and in good condition. Before using the recovery machine, check that it is in satisfactory working order, has been properly maintained and that any associated electrical components are sealed to prevent ignition in the event of a refrigerant release. Consult manufacturer if in doubt.

### Recovered Refrigerant

The recovered refrigerant should be returned to the refrigerant supplier in the correct recovery cylinder with the relevant waste transfer note assigned. Do not mix refrigerants in recovery units and especially not in cylinders.

### Compressor or Compressor Oils

If compressors or compressor oils are to be removed, ensure that they have been evacuated to an acceptable level to make certain that no refrigerant remains within the lubricant. The evacuation process should be carried out prior to returning compressors to the supplier(s). Only electric heating to the compressor body shall be employed to accelerate this process.

## Handling and Storage

### Precautions for Safe Handling

- Waste air is to be released into the atmosphere only via suitable separators. Open and handle receptacle with care.
- Keep ignition sources away.
- Do not smoke near the unit.
- Protect against electrostatic charges.

### Conditions for Safe Storage

- Requirements to be met by storerooms and receptacles:
  - Store only in unopened original receptacles
  - Store in a cool and dry location

- Further information about storage conditions:
  - Keep container tightly sealed
  - Store in cool, dry conditions in well sealed receptacle
  - Protect from heat and direct sunlight
- Maximum storage temperature:
  - 40°C

## Disposal

- Waste treatment method recommendation:
  - Must be specially treated adhering to official regulations.
  - Incineration in an adequate incinerator is recommended.
  - Uncleaned packaging disposal must be made according to official regulations.
- Ensure sufficient ventilation at the working place.
- Remove the refrigerant. A2L refrigerants should always be recovered and never released directly into the environment. Take care that the drained refrigerant will not cause any danger. In doubt, one person should guard the outlet. Take special care that drained refrigerant will not float back into the building.
- Evacuate the refrigerant circuit.
- Purge the refrigerant circuit with nitrogen for 5 min.
- Evacuate again.
- Cut out the compressor and drain the oil

## Competence of Personnel

There are specific procedures that must be followed for the installation, repair, maintenance, and decommissioning of equipment that uses A2L refrigerants.

Training for these procedures is carried out by national training organizations or manufacturers that are accredited to teach the relevant national competency standards that may be set in legislation. The achieved competence should be documented by a certificate.

## Information and Training

### *The training should include the substance of the following*

- Information about the explosion potential of flammable refrigerants to show that flammables may be dangerous when handled without care.
- Information about potential ignition sources, especially those that are not obvious, such as lighters, light switches, vacuum cleaners, electric heaters.
- Information about the different safety concepts:
  - Unventilated: Safety of the appliance does not depend on ventilation of the housing. Switching off the appliance or opening of the housing has no significant effect on safety. Nevertheless, it is possible that leaking refrigerant may accumulate inside the enclosure and flammable atmosphere will be released when the enclosure is opened.
  - Ventilated enclosure: Safety of the appliance depends

on ventilation of the housing. Switching off the appliance or opening of the enclosure has a significant effect on safety. Care should be taken to ensure sufficient ventilation before.

- Ventilated room: Safety of the appliance depends on the ventilation of the room. Switching off the appliance or opening of the housing has no significant effect on safety. The ventilation of the room shall not be switched off during repair procedures.
- Information about refrigerant detectors:
  - Principle of function, including influences on the operation.
  - Procedures, how to repair, check or replace a refrigerant detector or parts of it in a safe way.
  - Procedures, how to disable a refrigerant detector in case of repair work on the refrigerant carrying parts.
- Information about the concept of sealed components and sealed enclosures according to IEC 60079-15:2010.
- Information about the correct working procedures:
  - Commissioning
    - a. Ensure that the floor area is sufficient for the refrigerant charge or that the ventilation duct is assembled in a correct manner.
    - b. Connect the pipes and carry out a leak test before charging with refrigerant.
    - c. Check safety equipment before putting into service.
  - Maintenance
    - a. Portable equipment shall be repaired outside or in a workshop specially equipped for servicing units with flammable refrigerants.
    - b. Ensure sufficient ventilation at the repair place.
    - c. Be aware that malfunction of the equipment may be caused by refrigerant loss and a refrigerant leak is possible.
    - d. Discharge capacitors in a way that won't cause any spark. The standard procedure to short circuit the capacitor terminals usually creates sparks.
    - e. Reassemble sealed enclosures accurately. If seals are worn, replace them.
    - f. Check safety equipment before putting into service.
  - Repair
    - a. Portable equipment shall be repaired outside or in a workshop specially equipped for servicing units with flammable refrigerants.
    - b. Ensure sufficient ventilation at the repair place.
    - c. Be aware that malfunction of the equipment may be caused by refrigerant loss and a refrigerant leak is possible.
    - d. Discharge capacitors in a way that won't cause any spark.
    - e. When brazing is required, the following procedures shall be carried out in the right order:

- Removal of refrigerant. A2L refrigerants should always be recovered and never released directly into the environment. Take care that the drained refrigerant will not cause any danger. In doubt, one person should guard the outlet. Take special care that drained refrigerant will not float back into the building.
- Evacuation of the refrigerant circuit.
- Removal of parts to be replaced by cutting, not by flame.
- Purging the braze point with nitrogen during the brazing procedure.
- Carrying out a leak test before charging with refrigerant.
  - a. Reassemble sealed enclosures accurately. If seals are worn, replace them.
  - b. Check safety equipment before putting into service.
- Decommissioning
  - a. The refrigerant charge must be removed before decommissioning.
  - b. Ensure sufficient ventilation at the equipment location.
  - c. Be aware that malfunction of the equipment may be caused by refrigerant loss and a refrigerant leak is possible.
  - d. Discharge capacitors in a way that won't cause any spark.
  - e. Remove the refrigerant. A2L refrigerants should always be recovered and never released directly into the environment. Take care that the drained refrigerant will not cause any danger. In doubt, one person should guard the outlet. Take special care that drained refrigerant will not float back into the building.
- Disposal
  - a. Ensure sufficient ventilation at the working place.
  - b. Remove the refrigerant. A2L refrigerants should always be recovered and never released directly into the environment. Take care that the drained refrigerant will not cause any danger. In doubt, one person should guard the outlet. Take special care that drained refrigerant will not float back into the building.

## Maintenance

- Equipment shall be repaired outside or in a workshop specially equipped for servicing units with A2L refrigerants.
- Ensure sufficient ventilation at the location where repairs are taking place.
- Be aware that malfunction of the equipment may be caused by refrigerant loss and a refrigerant leak is possible.
- Discharge capacitors in a way that won't cause sparks.
- When repairs are Reassemble sealed enclosures. If seals are worn, replace them.
- Check safety equipment before putting into service.

## Repair

- Portable equipment shall be repaired outside or in a workshop specially equipped for servicing units with FLAMMABLE REFRIGERANTS.
- Ensure sufficient ventilation at the repair place.
- Be aware that malfunction of the equipment may be caused by refrigerant loss and a refrigerant leak is possible.
- Discharge capacitors in a way that won't cause any spark.
- When brazing is required, the following procedures shall be carried out in the right order:
  - Remove the refrigerant. A2L refrigerants should always be recovered and never released directly into the environment. Take care that the drained refrigerant will not cause any danger. In doubt, one person should guard the outlet. Take special care that drained refrigerant will not float back into the building.
  - Evacuate the refrigerant circuit.
  - Remove parts to be replaced by cutting, not by flame.
  - Purge the braze point with nitrogen during the brazing procedure.
  - Carry out a leak test before charging with refrigerant.
- Reassemble sealed enclosures accurately. If seals are worn, replace them.
- Check safety equipment before putting into service.

# Parts, Service, and Warranty Procedure

## Replacement Parts

When writing to Daikin Applied for service or replacement parts, refer to the model number and serial number of the unit stamped on the serial plate attached to the unit. If replacement parts are required, mention the date of installation of the unit and date of failure, along with an explanation of the malfunctions and a description of the replacement parts required.

## Warranty Return Material Procedure

Defective material may not be returned without permission of authorized factory service personnel of Daikin Applied in Minneapolis, Minnesota, (763) 553-5330. A "Return Goods" tag must be included with the returned material. Enter the required information to expedite handling and prompt issuance of credits. All parts must be returned to the appropriate Daikin Applied facility, designated on the "Return Goods" tag. Transportation charges must be prepaid.

The return of the part does not constitute an order for replacement. Therefore, a purchase order must be entered through the nearest Daikin Applied representative. The order should include part number, model number, and serial number of the unit involved.

# Limited Warranty



DAIKIN APPLIED AMERICAS INC.  
LIMITED PRODUCT WARRANTY  
(United States and Canada)

## WARRANTY

Daikin Applied Americas Inc. dba Daikin Applied ("Company") warrants to contractor, purchaser and any owner of the product (collectively "Owner") that, subject to the exclusions set forth below Company, at its option, will repair or replace defective parts in the event any product manufactured by Company, including products sold under the brand name Daikin and used in the United States or Canada, proves defective in material or workmanship within twelve (12) months from initial startup or eighteen (18) months from the date shipped by Company, whichever occurs first. Authorized replacement parts are warranted for the remainder of the original warranty. All shipments of such parts will be made FOB factory, freight prepaid and allowed. Company reserves the right to select carrier and method of shipment. In addition, Company provides labor to repair or replace warranty parts during Company normal working hours on products with rotary screw compressors or centrifugal compressors. Warranty labor is not provided for any other products.

Company must receive the Registration and Startup Forms for products containing motor compressors and/or furnaces within ten (10) days of original product startup, or the ship date and the startup date will be deemed the same for determining the commencement of the warranty period and this warranty shall expire twelve (12) months from that date. For additional consideration, Company will provide an extended warranty(ies) on certain products or components thereof. The terms of the extended warranty(ies) are shown on a separate extended warranty statement.

No person (including any agent, sales representative, dealer or distributor) has the authority to expand the Company's obligation beyond the terms of this express warranty or to state that the performance of the product is other than that published by Company.

## EXCLUSIONS

1. If free warranty labor is available as set forth above, such free labor does not include diagnostic visits, inspections, travel time and related expenses, or unusual access time or costs required by product location.
2. Refrigerants, fluids, oils and expendable items such as filters are not covered by this warranty.
3. This warranty shall not apply to products or parts : (a) that have been opened, disassembled, repaired, or altered, in each case by anyone other than Company or its authorized service representative; (b) that have been subjected to misuse, abuse, negligence, accidents, damage, or abnormal use or service; (c) that have not been properly maintained; (d) that have been operated or installed, or have had startup performed, in each case in a manner contrary to Company's printed instructions; (e) that have been exposed, directly or indirectly, to a corrosive atmosphere or material such as, but not limited to, chlorine, fluorine, fertilizers, waste water, urine, rust, salt, sulfur, ozone, or other chemicals, contaminants, minerals, or corrosive agents; (f) that were manufactured or furnished by others and/or are not an integral part of a product manufactured by Company; or (g) for which Company has not been paid in full.
4. This warranty shall not apply to products with rotary screw compressors or centrifugal compressors if such products have not been started, or if such startup has not been performed, by a Daikin Applied or Company authorized service representative.

## SOLE REMEDY AND LIMITATION OF LIABILITY

THIS WARRANTY CONSTITUTES THE SOLE WARRANTY MADE BY COMPANY. COMPANY'S LIABILITY TO OWNER AND OWNER'S SOLE REMEDY UNDER THIS WARRANTY SHALL NOT EXCEED THE LESSER OF: (i) THE COST OF REPAIRING OR REPLACING DEFECTIVE PRODUCTS; AND (ii) THE ORIGINAL PURCHASE PRICE ACTUALLY PAID FOR THE PRODUCTS. COMPANY MAKES NO REPRESENTATION OR WARRANTY, EXPRESS OR IMPLIED, REGARDING PREVENTION OF MOLD/MOULD, FUNGUS, BACTERIA, MICROBIAL GROWTH, OR ANY OTHER CONTAMINATES. THIS WARRANTY IS GIVEN IN LIEU OF ALL OTHER WARRANTIES, INCLUDING, WITHOUT LIMITATION, THE IMPLIED WARRANTIES OF MERCHANTABILITY, FITNESS FOR A PARTICULAR PURPOSE, AND NON-INFRINGEMENT, WHICH ARE HEREBY DISCLAIMED. IN NO EVENT AND UNDER NO CIRCUMSTANCE SHALL COMPANY BE LIABLE TO OWNER OR ANY THIRD PARTY FOR INCIDENTAL, INDIRECT, SPECIAL, CONTINGENT, CONSEQUENTIAL, DELAY OR LIQUIDATED DAMAGES FOR ANY REASON, ARISING FROM ANY CAUSE WHATSOEVER, WHETHER THE THEORY FOR RECOVERY IS BASED IN LAW OR IN EQUITY, OR IS UNDER A THEORY OF BREACH CONTRACT OR WARRANTY, NEGLIGENCE, STRICT LIABILITY, OR OTHERWISE. THE TERM "CONSEQUENTIAL DAMAGE" INCLUDES, WITHOUT LIMITATION, THOSE DAMAGES ARISING FROM BUSINESS INTERRUPTION OR ECONOMIC LOSS, SUCH AS LOSS OF ANTICIPATED PROFITS, REVENUE, PRODUCTION, USE, REPUTATION, DATA OR CROPS.

## ASSISTANCE

To obtain assistance or information regarding this warranty, please contact your local sales representative or a Daikin Applied office.

Form No. 933-430285Y-01-A (11/2023)  
Part No. 043028500 Rev.0F

# Warranty Registration Form



## Air Handling Equipment Warranty Registration Form

To comply with the terms of Daikin Applied Warranty, register the start date and upload this form within 10 days to the Warranty Department of Daikin Applied.

Check, test, and start procedure for air handling units with or without heat recovery and roof mounted air handlers.

### GENERAL INFORMATION

Job Name: \_\_\_\_\_ Unit No.: \_\_\_\_\_

SOI No.: \_\_\_\_\_

Installation address: \_\_\_\_\_

City: \_\_\_\_\_ State: \_\_\_\_\_

Purchasing contractor: \_\_\_\_\_

City: \_\_\_\_\_ State: \_\_\_\_\_

Name of person doing start-up: \_\_\_\_\_

Company name: \_\_\_\_\_

Address: \_\_\_\_\_

City/State/Zip: \_\_\_\_\_

### UNIT INFORMATION

Unit model number: \_\_\_\_\_ Unit serial number: \_\_\_\_\_

SF VFD model number: \_\_\_\_\_ Serial number: \_\_\_\_\_

RF VFD model number: \_\_\_\_\_ Serial number: \_\_\_\_\_



AHU Equipment Warranty Registration Form (continued)

Select Yes or No. If not applicable to the type of unit, select N/A.

I. INITIAL CHECK

- A. Is any shipping damage visible? . . . . .  Yes  No  N/A
- B. Are fan drives properly aligned and belts properly adjusted? . . . . .  Yes  No  N/A
- C. Tightened all setscrews on pulleys, bearings and fans? . . . . .  Yes  No  N/A
- D. Have the hold-down bolts been backed off on spring mounted fan isolators? . . . . .  Yes  No  N/A
- E. With the power off, do fans turn freely by hand? . . . . .  Yes  No  N/A
- F. Electrical service corresponds to unit nameplate? . . . . .  Yes  No  N/A

Volts \_\_\_\_\_ Hertz \_\_\_\_\_ Phase \_\_\_\_\_

- G. Is the main disconnect adequately fused and are fuses installed? . . . . .  Yes  No  N/A
- H. Are all electrical power connections tight? (Check compressor, electrical box.) . . . . .  Yes  No  N/A
- I. Is the condensate drain trapped? . . . . .  Yes  No  N/A
- J. Fill the drain pan. Does water drain freely? . . . . .  Yes  No  N/A
- K. Is the unit mounted level? . . . . .  Yes  No  N/A

II. FAN DATA

- A. Check rotation of supply fan(s)? . . . . .  Yes  No  N/A
- B. Voltage at supply fan motor(s): . . . . . 1-2 \_\_\_\_\_ V 2-3 \_\_\_\_\_ V 1-3 \_\_\_\_\_ V  
 \*Fan array units only . . . . . 1-2 \_\_\_\_\_ V 2-3 \_\_\_\_\_ V 1-3 \_\_\_\_\_ V  
 1-2 \_\_\_\_\_ V 2-3 \_\_\_\_\_ V 1-3 \_\_\_\_\_ V  
 1-2 \_\_\_\_\_ V 2-3 \_\_\_\_\_ V 1-3 \_\_\_\_\_ V  
 1-2 \_\_\_\_\_ V 2-3 \_\_\_\_\_ V 1-3 \_\_\_\_\_ V  
 1-2 \_\_\_\_\_ V 2-3 \_\_\_\_\_ V 1-3 \_\_\_\_\_ V
- C. Supply fan motor amp draw(s) per phase: . . . . . L1 \_\_\_\_\_ L2 \_\_\_\_\_ L3 \_\_\_\_\_  
 \*Fan array units only . . . . . L1 \_\_\_\_\_ L2 \_\_\_\_\_ L3 \_\_\_\_\_  
 L1 \_\_\_\_\_ L2 \_\_\_\_\_ L3 \_\_\_\_\_  
 L1 \_\_\_\_\_ L2 \_\_\_\_\_ L3 \_\_\_\_\_  
 L1 \_\_\_\_\_ L2 \_\_\_\_\_ L3 \_\_\_\_\_  
 L1 \_\_\_\_\_ L2 \_\_\_\_\_ L3 \_\_\_\_\_
- D. Overload amp setting: . . . . . \_\_\_\_\_
- E. What is the supply fan rpm? . . . . . \_\_\_\_\_
- F. Check rotation of return fan(s)? . . . . .  Yes  No  N/A



AHU Equipment Warranty Registration Form (continued)

Select Yes or No. If not applicable to the type of unit, select N/A.

G. Voltage at return fan motor(s): . . . . . 1-2 \_\_\_\_\_ V 2-3 \_\_\_\_\_ V 1-3 \_\_\_\_\_ V  
 \*Fan array units only . . . . . 1-2 \_\_\_\_\_ V 2-3 \_\_\_\_\_ V 1-3 \_\_\_\_\_ V  
 . . . . . 1-2 \_\_\_\_\_ V 2-3 \_\_\_\_\_ V 1-3 \_\_\_\_\_ V  
 . . . . . 1-2 \_\_\_\_\_ V 2-3 \_\_\_\_\_ V 1-3 \_\_\_\_\_ V  
 . . . . . 1-2 \_\_\_\_\_ V 2-3 \_\_\_\_\_ V 1-3 \_\_\_\_\_ V  
 . . . . . 1-2 \_\_\_\_\_ V 2-3 \_\_\_\_\_ V 1-3 \_\_\_\_\_ V

H. Return fan motor amp draw(s) per phase: . . . . . L1 \_\_\_\_\_ L2 \_\_\_\_\_ L3 \_\_\_\_\_  
 \*Fan array units only . . . . . L1 \_\_\_\_\_ L2 \_\_\_\_\_ L3 \_\_\_\_\_  
 . . . . . L1 \_\_\_\_\_ L2 \_\_\_\_\_ L3 \_\_\_\_\_  
 . . . . . L1 \_\_\_\_\_ L2 \_\_\_\_\_ L3 \_\_\_\_\_  
 . . . . . L1 \_\_\_\_\_ L2 \_\_\_\_\_ L3 \_\_\_\_\_  
 . . . . . L1 \_\_\_\_\_ L2 \_\_\_\_\_ L3 \_\_\_\_\_

I. Overload amp setting: . . . . . \_\_\_\_\_

J. What is the return fan rpm? . . . . . \_\_\_\_\_

K. Record supply static pressure at unit in inches of H<sub>2</sub>O: . . . . . \_\_\_\_\_

L. Record return static pressure at unit (with outside air dampers closed) in inches of H<sub>2</sub>O: . . . . . \_\_\_\_\_

\* If additional fans are on the unit, please add them to the space below.

III. DAMPERS

A. Are blades and seals present? . . . . .  Yes  No  N/A

B. Do damper open smoothly and shut tight? . . . . .  Yes  No  N/A



AHU Equipment Warranty Registration Form (continued)

Select Yes or No. If not applicable to the type of unit, select N/A.

IV. ELECTRIC HEAT

A. Electrical heat service corresponds to unit nameplate? . . . . .  Yes  No  N/A

Volts \_\_\_\_\_ Hertz \_\_\_\_\_ Phase \_\_\_\_\_

B. Are there any signs of physical damage to the electric heat coils? . . . . .  Yes  No  N/A

C. Have all electrical terminals been tightened? . . . . .  Yes  No  N/A

D. Does sequence controller stage contactors properly? . . . . .  Yes  No  N/A

E. Electric heater voltage across each phase: . . . . . \_\_\_\_\_ L1 \_\_\_\_\_ L2 \_\_\_\_\_ L3

F. Amp draw across each phase at each heating stage:

	Stage 1	Stage 2	Stage 3	Stage 4	Stage 5	Stage 6
Phase L1:	_____	_____	_____	_____	_____	_____
Phase L2:	_____	_____	_____	_____	_____	_____
Phase L3:	_____	_____	_____	_____	_____	_____

G. FLA: L1 \_\_\_\_\_ L2 \_\_\_\_\_ L3 \_\_\_\_\_

H. Operate electric heat with fans off. Electric heat must cycle on high limit control . . . . .  Yes  No  N/A

V. CHILLED WATER COIL

A. Pressure test OK? . . . . .  Yes  No  N/A

B. Drain pan draining OK? . . . . .  Yes  No  N/A

VI. HOT WATER COIL

A. Pressure test OK? . . . . .  Yes  No  N/A

VII. HEAT RECOVERY

A. Heat wheel rotates freely? . . . . .  Yes  No  N/A

B. Heat wheel VFD operates properly? . . . . .  Yes  No  N/A

C. Heat wheel VFD: . . . . . .Model # \_\_\_\_\_ Serial # \_\_\_\_\_

D. Check for air bypass around heat wheel. . . . .  Yes  No  N/A



AHU Equipment Warranty Registration Form (continued)

Select Yes or No. If not applicable to the type of unit, select N/A.

VIII. Design Flow calibration

- A. Verify power is supplied to the MicroTech III unit controller . . . . .  Yes  No  N/A
- B. Verify that the shipping screws have been removed from the measuring station vane . . . . .  Yes  No  N/A
- C. Examine station for damage . . . . .  Yes  No  N/A
- D. Record Level Position after calibration
  - LH Level Position . . . . . \_\_\_\_\_
  - RH Level Position . . . . . \_\_\_\_\_

NOTE: This is viewed in the MicroTech III controller, in the Min OA setup menu.

IX. GAS BURNER CHECK, TEST, & START

Specifications:

For gas, see **Forced Draft Gas Burner Installation and Maintenance Bulletin. (IM 684 and IM 685)**

- A. Gas Furnace: . . . . . Model no. \_\_\_\_\_
- B. Gas Burner: . . . . . Model no. \_\_\_\_\_ Serial no. \_\_\_\_\_
- C. Gas Type firing: . . . . . Single Stage \_\_\_\_\_ Modulation \_\_\_\_\_
- D. Gas Rated firing rate (MBH input): . . . . . \_\_\_\_\_
- E. Gas Altitude (ft. above sea level): . . . . . \_\_\_\_\_
- F. Is there a circulating tank? . . . . .  Yes  No  N/A
- G. Input (CFH): . . . . . \_\_\_\_\_
- H. Gas pressure at burner (inches w.c.): . . . . . \_\_\_\_\_
- I. CO<sub>2</sub> (%): . . . . . \_\_\_\_\_
- J. CO<sub>2</sub> (%): . . . . . \_\_\_\_\_
- K. Pilot flame only in microamps (steady at low fire): . . . . . \_\_\_\_\_
- L. Pilot Tap-gas pressure (inches w.c.): . . . . . \_\_\_\_\_
- M. Motor only/burner FLA running amps: . . . . . \_\_\_\_\_
- N. High limit control OK? . . . . .  Yes  No  N/A
- O. Flame safeguard (microamps): . . . . . \_\_\_\_\_
- P. Flame failure shutoff (seconds): . . . . . \_\_\_\_\_



AHU Equipment Warranty Registration Form (continued)

Select Yes or No. If not applicable to the type of unit, select N/A.

- Q. Airswitch OK? . . . . .  Yes  No  N/A
- R. High Gas Pressure Switch OK? . . . . .  Yes  No  N/A
- S. Low Gas Pressure Switch OK? . . . . .  Yes  No  N/A
- T. Main Gas Valve Close-off OK? . . . . .  Yes  No  N/A

Thank you for completing this form. Please sign and date below.

Signature \_\_\_\_\_ Startup date: \_\_\_\_\_

Register equipment start date and upload form on the Daikin Applied FieldCare Portal at <https://fieldcare.daikinapplied.com>

Please fill out the Daikin Applied "Quality Assurance Survey Report" and list any additional comments that could affect the operation of this unit; e.g., shipping damage, failed components, adverse installation applications, etc. If additional comment space is needed, write the comment(s) on a separate sheet, attach it to the Survey Report and return it to the Warranty Department of Daikin Applied with the completed Equipment Warranty Registration form.

Clear Form

# Quality Assurance Survey



## Quality Assurance Survey Report

To whom it may concern:

Please review the items below upon receiving and installing our product. Select N/A on any item that does not apply to the product.

**Job Name:** \_\_\_\_\_ **Daikin Applied S.O. No.** \_\_\_\_\_

Installation address: \_\_\_\_\_

City: \_\_\_\_\_ State: \_\_\_\_\_

Purchasing contractor: \_\_\_\_\_

City: \_\_\_\_\_ State: \_\_\_\_\_

**Name of person doing start-up (print):** \_\_\_\_\_

Company name: \_\_\_\_\_

Address: \_\_\_\_\_

City/State/Zip: \_\_\_\_\_

**Unit model number:** \_\_\_\_\_ **Unit serial number:** \_\_\_\_\_

1. Is there any shipping damage visible? ..... Yes  No  N/A

Location on unit \_\_\_\_\_

2. How would you rate the overall appearance of the product; i.e., paint, fin damage, etc.? ..... Excellent  Good  Fair  Poor

3. Did all sections of the unit fit together properly? ..... Yes  No  N/A

4. Did the cabinet have any air leakage? ..... Yes  No  N/A

Location on unit \_\_\_\_\_

5. Were there any refrigerant leaks? ..... Yes  No  N/A

From where did it occur? ..... Shipping  Workmanship  Design

6. Does the refrigerant piping have excessive vibration? ..... Yes  No  N/A

Location on unit \_\_\_\_\_

7. Did all of the electrical controls function at start-up? ..... Yes  No  N/A

Comments \_\_\_\_\_

8. Did the labeling and schematics provide adequate information? ..... Yes  No  N/A

9. How would you rate the serviceability of the product? ..... Excellent  Good  Fair  Poor

10. How would you rate the overall quality of the product? ..... Excellent  Good  Fair  Poor

11. How does the quality of Daikin Applied products rank in relation to competitive products? ..... Excellent  Good  Fair  Poor

Comments \_\_\_\_\_

Please list any additional comments which could affect the operation of this unit; i.e., shipping damage, failed components, adverse installation applications, etc. If additional comment space is needed, write the comment(s) on a separate sheet, attach the sheet to this completed Quality Assurance Survey Report, and return it to the Warranty Department with the completed preceding "Equipment Warranty Registration Form".

# COMPLETE HVAC SYSTEM SOLUTIONS

SELF-CONTAINED | ROOFTOPS | COILS | CONDENSING UNITS  
AIR HANDLERS | WATER-COOLED CHILLERS | AIR-COOLED CHILLERS  
MODULAR CENTRAL PLANTS | CONNECTED BUILDING CONTROLS  
UNIT HEATERS | FAN COILS | AIR PURIFIERS | WATER SOURCE HEAT PUMPS  
VARIABLE AIR VOLUME UNITS | UNIT VENTILATORS



13600 INDUSTRIAL PARK BLVD. | MINNEAPOLIS, MN 55441  
1-800-432-1342 | 763-553-5330

LEARN MORE AT  
**DAIKINAPPLIED.COM**

PART NUMBER: IM777

© 2026 DAIKIN APPLIED | (800) 432.1342 | WWW.DAIKINAPPLIED.COM