

# STEAM COILS



- TYPES: HI-F5, HI-F8, AND E-F5

**Introduction** . . . . . **3**  
    General Information . . . . . 3  
**Installation** . . . . . **4**  
    Mounting . . . . . 4  
    Installation Procedure . . . . . 4  
**Operation and Maintenance** . . . . . **7**

©2023 Daikin Applied, Minneapolis, MN. All rights reserved throughout the world. This document contains the most current product information as of this printing. Daikin Applied Americas Inc. has the right to change the information, design, and construction of the product represented within the document without prior notice. For the most up-to-date product information, please go to [www.DaikinApplied.com](http://www.DaikinApplied.com).

™@ MicroTech, SiteLine, and Daikin Applied are trademarks or registered trademarks of Daikin Applied Americas Inc. The following are trademarks or registered trademarks of their respective companies: BACnet from American Society of Heating, Refrigerating and Air-Conditioning Engineers, Inc.; Echelon, LonWorks, LonMark, and LonTalk from Echelon Corporation; Modbus from Schneider Electric; and Windows from Microsoft Corporation..

# Introduction

## General Information

These are general guidelines for the installation, operation and maintenance of Daikin Applied steam heating. They may have to be tailored to meet the specific requirements of any one job. An experienced installation company or fully trained personnel should perform the installation and maintenance of any coil.

## Hazard Identification Information

### DANGER

Dangers indicate a hazardous situation which will result in death or serious injury if not avoided.

### WARNING

Warnings indicate potentially hazardous situations, which can result in property damage, severe personal injury, or death if not avoided.

### CAUTION

Cautions indicate potentially hazardous situations, which can result in personal injury or equipment damage if not avoided.

## Receiving Instructions

1. Coils should be inspected for shipping damage upon receipt. The freight bill should also be checked against items received for complete delivery.
2. Damaged and/or missing items should be noted on the carrier's freight bill and signed by the driver.
3. Coils are factory tested at 315 psig (minimum air pressure) while submersed in water.
4. For additional assistance, contact your local Daikin Applied sales representative.

## Storage Instructions

1. Carefully remove all shipping wrap material and open the shipping crate. Inspect the coil for shipping damage and report it immediately if damage is found.
2. Cap the coil to protect coil openings from damage and infestation.
3. Re-crate the coil. Do not re-apply shipping wrap material.
4. Store the coil indoors in a clean, dry environment on a level surface. Ensure adequate support is used to prevent the coil from sagging, if raised.
5. Do not stack coils or store anything on top of the coil.
6. Isolate coil from shocks and vibrations, if necessary.
7. Do not clean galvanized steel surfaces with oil dissolving chemicals. This may remove the protective coating and accelerate corrosion.
8. Any damage to the coil resulting from improper storage will not be covered by Daikin Applied's warranty terms.

## Coil Types

### Distributing

Daikin Applied models JA, RA and DA jet-tube steam distributing coils (see Figure 1) are excellent for any general purpose heating application. With the superior freeze resistance provided by the tube-with-in-a-tube construction, it is ideal for low temperature preheating and special process applications. The construction features inner tubes with directional orifices to aid in steam distribution and condensate removal. Model JA offers same-end supply and return connections. Model RA offers opposite-end supply and return connections. Model DA offers dual-supply opposite-end connections for long coils that see sub-freezing air temperatures. Models GA, TA and LA utilize cupro-nickel, carbon steel and stainless steel tubing for high-pressure construction.

### Single Tube

Daikin Applied model SA steam coils (see Figure 1) are designed for general purpose heating. The construction features a single tube design with opposite-end supply and return connections. A perforated baffle located directly behind the supply connection ensures proper steam distribution. Model HA utilizes cupro-nickel, carbon steel and stainless steel tubing for high-pressure construction.

Figure 1: Coil Types

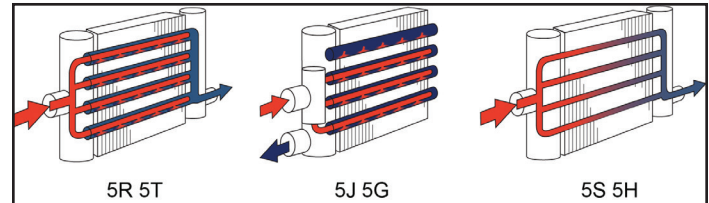

# Installation

## Mounting

Steam coils must be properly mounted for condensate removal. This will aid in preventing destructive water hammer, keeping coils from freezing and preventing corrosive elements from collecting in the tubes. Case-pitched coils (Figure 2) should be installed level. Daikin Applied models SA, SB, HA, JA, GA, DA, LA, RA and TA come standard pitched in the casing.

Coils that are un-pitched (Figure 3) must be installed with the tubes pitched towards the return connection. A minimum pitch of 1/8" per foot of coil length is required (pitch has been exaggerated in image). Coils with opposite end connections (RA, TA, SA, & HA) should be furnished with an expansion joint or provisions made for expansion on opposite connection end.

Figure 2: Case Pitched

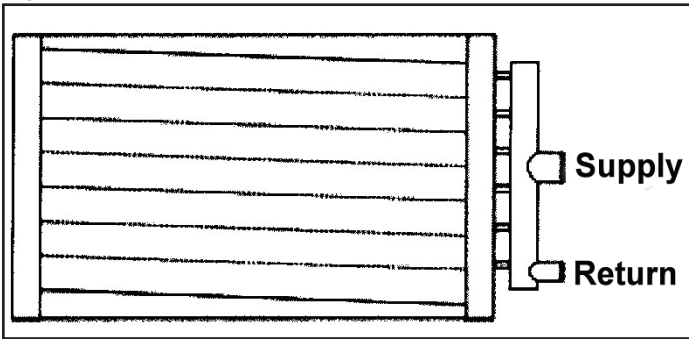
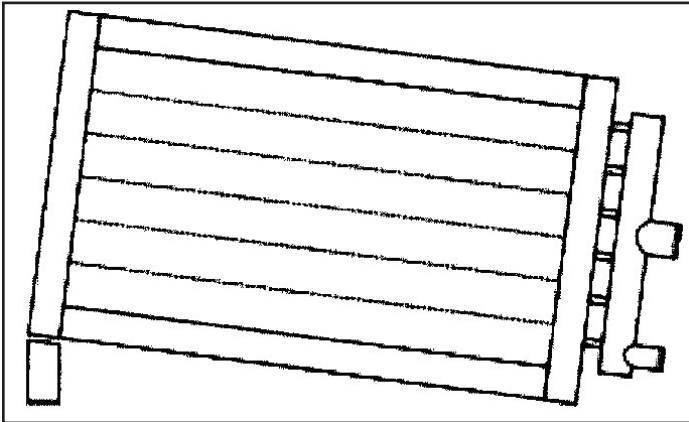

Figure 3: Case Un-pitched



## Installation Procedure

**⚠ WARNING**

Steam, even at low pressure, can cause serious bodily injury that may result in death. Be sure the system is off or the components are isolated before beginning work..

**⚠ CAUTION**

**Sharp edges on sheet metal and fasteners can cause personal injury.** This equipment must be installed, operated, and serviced only by an experienced installation company and fully trained personnel. Protective equipment such as safety glasses, steel toe boots and gloves are recommended during the installation and routine maintenance of the coil.

**⚠ CAUTION**

Failure to properly install the coil can result in irreparable damage to the coil as well as other components in the system.

If you are unsure about any portion of the installation, contact your local steam specialist for assistance.

1. Carefully remove the coil from the shipping package to avoid damage to the finned area. Damaged fins can be straightened using an appropriate fin comb.
2. Daikin Applied recommends cleaning the coil with a commercially available coil cleaner prior to installation. Refer to "Operation and Maintenance" on page 7 for cleaning recommendations.

**NOTE:** Vacuum breakers and air vents should be piped to a drain or other suitable location where discharged steam cannot lead to personal injury.

3. Mount coil properly to provide positive condensate drainage. Refer to the "Mounting" section.
4. Proper clearance should be maintained between the coil and other structures such as the fan, filter racks, transition areas, etc.
5. Utilize vacuum breakers on each coil. Steam traps require a positive pressure differential to force the condensate through the valve seat. If the coil's pressure drops below atmospheric, the pressure differential across the valve will be negative and the condensate will not drain. This condition can lead to serious damage or failure of the coil due to freezing, water hammer, or corrosion. Refer to Figure 4 and Figure 4 for recommended placement.
6. Trap each coil separately. Differences in pressure from coil to coil can result in the backing up of condensate that will result in poor coil performance and possible damage.
7. Provide an air vent for each coil at its highest location. Non-condensable gasses present in the steam will collect in a coil and reduce its capacity. Therefore, it is necessary to provide a means for the removal of these gasses. Also, these gasses can diffuse into the condensate forming bi-products, which can lead to severe corrosion.
8. Steam supply lines need to be drained of condensate. This can be accomplished by the use of drip legs. This ensures that high quality steam enters the coil.

9. Condensate return piping should be the same size as the coil's return connection from the coil outlet to the steam trap.
  10. Once installed, the coil should be pressurized to 100 psig with dry nitrogen or an other suitable gas. The coil should be left pressurized for a minimum of 10 minutes. If the coil holds the pressure, the hook-up can be considered leak free. If the pressure drops by 5 psig or less, re-pressurize the coil and wait another 10 minutes. If the pressure drops again, there are more than likely one or more small leaks, which should be located and repaired. Pressure losses greater than 5 psig would indicate a larger leak, which should be isolated and repaired. Be sure to check valves and fittings as potential sites for leakage or bleed. If the coil itself is found to be leaking, contact your local Daikin Applied representative.
- NOTE:** Unauthorized repair to the coil may void the coil's warranty (see Daikin Applied's warranty policy on back cover).
11. All field brazing and welding should be performed using high quality materials and an inert gas purge (such as nitrogen) to reduce oxidation of the internal surface of the coil.
  12. All field piping must be self-supporting. System piping should be flexible enough to allow for thermal expansion and contraction of the coil. The use of flexible connections and/or swing joints is recommended.
  13. The coil along with the control valve and trap should be isolated by manual valves to allow for servicing.

Figure 4: High Pressure Steam Coil Piping Diagram

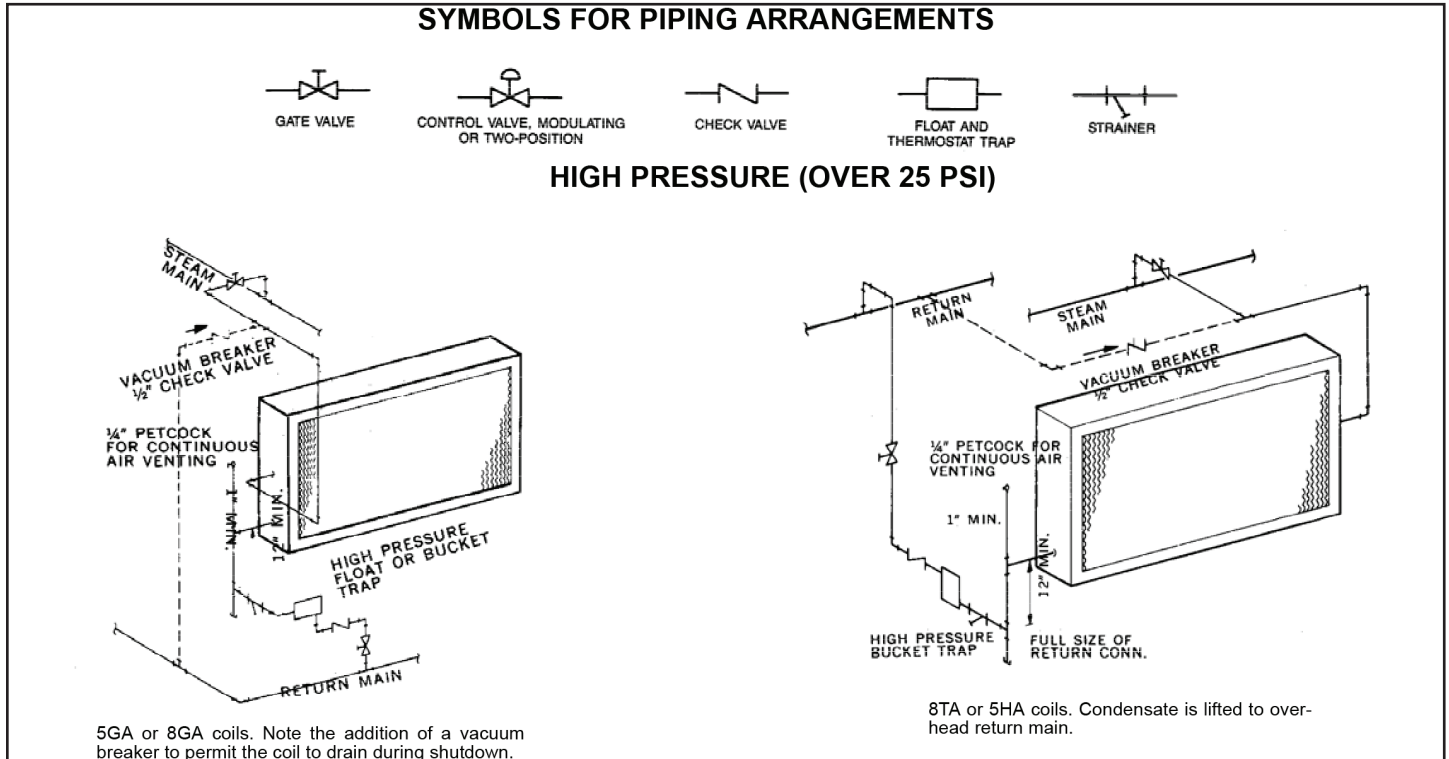
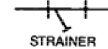
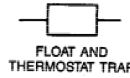
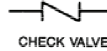
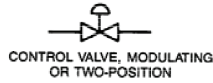
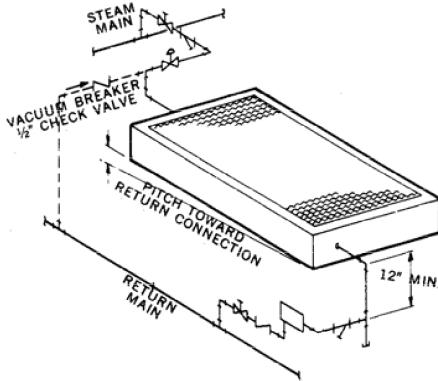

Figure 5: Low Pressure Steam Coil Piping Diagram

**SYMBOLS FOR PIPING ARRANGEMENTS**



**LOW PRESSURE (TO 25 PSI)**



\*5JA or 8JA coil installed with tubes vertical. The coil supply piping must be dripped ahead of the coil on an installation of this type.

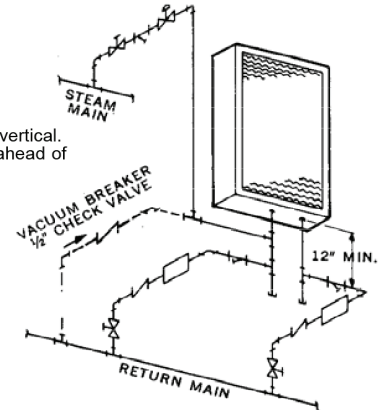

\*5SA coil installed for vertical airflow. Installer must pitch coil toward the return connection on vertical airflow installations. For horizontal airflow installation, the required pitch is built into the casing.

\* NOTE: Rating data is ARI certified only for the standard ARI coil orientation; i.e., horizontal tubes, vertical coil face and horizontal airflow.

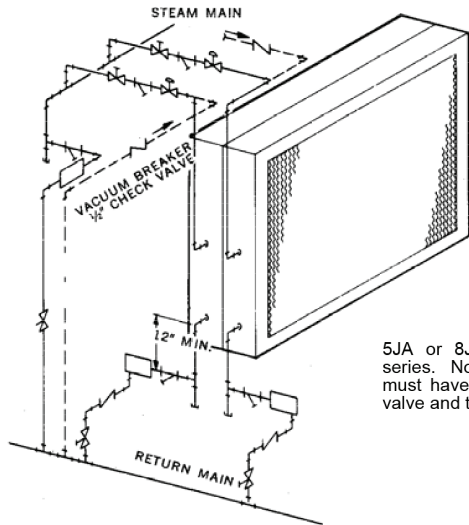

5JA or 8JA coil installed in series. Note that each coil must have a separate control valve and trap.

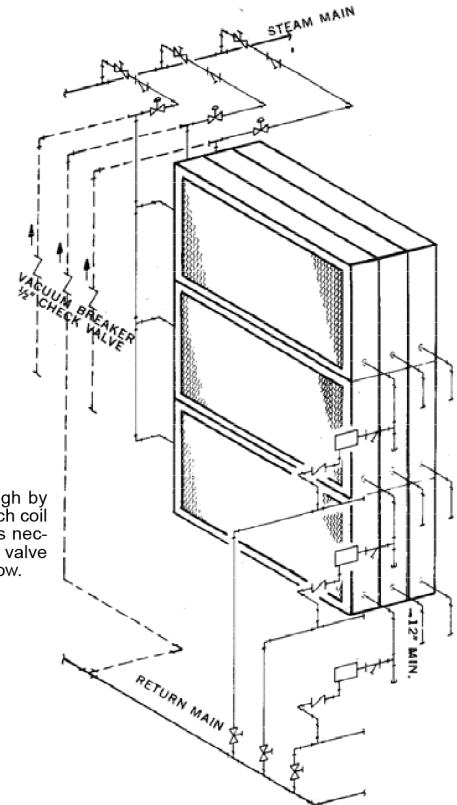

8RA and 5SA coils banked three high by three deep. Individual trapping of each coil as shown is preferred. Note that it is necessary to provide a separate control valve for each bank in the direction of airflow.

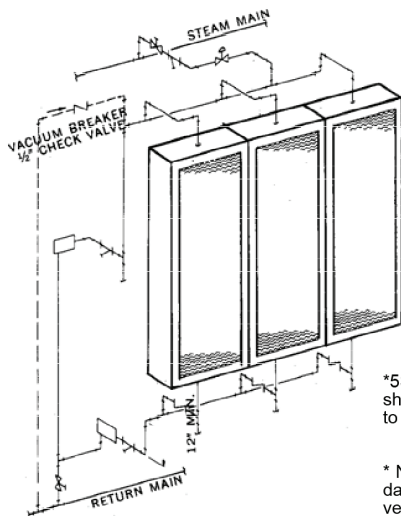

\*5SA coils installed with tubes vertical. Diagram shows single trap; however, it is always preferable to trap each coil individually.

\* NOTE: Rating data is ARI certified only for standard ARI coil orientation; i.e., horizontal tubes, vertical coil face and horizontal airflow.

# Operation and Maintenance

## Operation

1. Proper air distribution is vital to coil performance. Airflow anywhere on the coil face should not vary by more than 20%.
2. Air velocities should be maintained within Daikin Applied's recommended values of between 200 and 1500 fpm.
3. Operating pressures must be at or below the maximum operating pressure for that coil at the steam temperature. Operating pressure maximum is 150 psig @ 300 F for low pressure steam coils and 350 psig @ 450 F for high pressure steam coils.

## Maintenance

### WARNING

Follow the manufacturer's guidelines for lockout/tagout and disconnect all power to the unit before performing maintenance. Contact with high voltage power will cause electrical shock, resulting in severe personal injury or death.

### CAUTION

Moving parts, high pressure, and/or high temperature fluids can cause serious personal injury.

1. Filters should be inspected on a regular basis and changed as needed. Clean filters help maintain maximum coil performance and service life.
2. Periodic inspection of the coil for signs of corrosion and/or leaks is recommended. Repair and replacement of the coil and the connecting piping, valves, etc., should be performed as needed by a qualified individual.
3. Should the coil surface need cleaning, caution should be exercised in selecting the cleaning solution as well as the cleaning equipment. Improper selection can result in damage to the coil and/or health hazards.
4. Suggested cleaning instructions:
  - a. When handling strong chemicals, be sure to wear chemical impervious gloves, apron, and splash goggles.
  - b. Acti-Brite (AB-1) is the recommended cleaning solution. Contact your local Daikin Parts Distributor.

### CAUTION

Carefully read and follow the manufacturer's recommendations before using any cleaning fluid.

- c. Determine required dilution for the specific application. It is recommended to start with a dilution ratio of 10:1 and increase concentration until the desired results are achieved.
- d. As with mixing all acids, place the desired amount of water into the tank and then add the chemicals.
- e. Turn off fans and allow hot coils to cool before applying.

- f. Using plain water, wet both the coil as well as the area surrounding the equipment. Wetting the coil with water aids in product penetration and performance.
- g. Apply properly diluted product to coil surface. Whenever possible, apply solution from the outlet side of the coil. Allow solution to remain on surface, normally 5-10 minutes. Do not allow solution to dry on the coil.

**NOTE:** In extreme cases, application may have to be repeated to achieve desired results.

- h. If foaming does not occur, check for extreme grease buildup which will slow cleaning process. Foaming may not occur if coil is coated or painted.
- i. Rinse coils, tools and surrounding area thoroughly after the coil cleaning.
- j. Clean the coil from the leaving airside so that foreign material will be washed out of the coil rather than pushed further in.

5. Internal coil maintenance consists of preventing scale and corrosion. This is accomplished through aggressive boiler water treatment, removal of dissolved oxygen and the removal of non-condensable gasses such as carbon dioxide.

**NOTE:** Boiler water treatment is beyond the scope of this manual. Contact your local water treatment specialist for assistance in establishing a proper boiler-water treatment program.

# COMPLETE HVAC SYSTEM SOLUTIONS

SELF-CONTAINED | ROOFTOPS | COILS | CONDENSING UNITS  
AIR HANDLERS | WATER-COOLED CHILLERS | AIR-COOLED CHILLERS  
MODULAR CENTRAL PLANTS | SITELINE BUILDING CONTROLS  
UNIT HEATERS | FAN COILS | AIR PURIFIERS | WATER SOURCE HEAT PUMPS  
VARIABLE AIR VOLUME UNITS | UNIT VENTILATORS



13600 INDUSTRIAL PARK BLVD. | MINNEAPOLIS, MN 55441  
1-800-432-1342 | 763-553-5330

LEARN MORE AT  
**DAIKINAPPLIED.COM**

PART NUMBER: IM 901-1

© 2023 DAIKIN APPLIED | (800) 432.1342 | WWW.DAIKINAPPLIED.COM