



# Installation and Maintenance Manual

# IM 1049-14

Group: **WSHP**

Part Number: **IM1049-14**

Date: **May 2024**

## Daikin Enfinity™ Horizontal Water Source Heat Pumps R-410A Refrigerant

Model CCH, CCW Unit Sizes 007 – 070





<b>Safety and Precautions</b> .....	<b>4</b>	<b>Typical Wiring Diagrams</b> .....	<b>33</b>
Hazard Identification Information .....	4	MicroTech III Controller with PSC Motor – 115-60-1 Unit Sizes 007-009 .....	33
<b>Model Nomenclature</b> .....	<b>5</b>	MicroTech III Controller with PSC Motor, Communication Module – 208/230-60-1 Unit Sizes 015-060 .....	34
<b>Prior To Installing</b> .....	<b>6</b>	MicroTech III Controller with PSC Motor – 208/230/460-60-3 Unit Sizes 024-070 .....	35
Receiving and Storage .....	6	MicroTech III Controller with EC Motor and Optional Comm – 208/230-60-3 Unit Sizes 007–012 .....	36
Pre-Installation .....	6	MicroTech III Controller with EC Motor and Optional Comm – 208/230-60-1 Unit Sizes 019-070 .....	37
<b>Installation Considerations</b> .....	<b>7</b>	MicroTech III Controller with EC Motor and Optional Communication Module – 460-60-3 Unit Sizes 024- 070 .....	38
Unit Location .....	7	<b>Thermostats and Wall Sensors</b> .....	<b>39</b>
Filter Access .....	8	Thermostats and Remote Indoor Sensor .....	39
Air Discharge Conversion .....	8	Room Temperature Sensors .....	40
Ductwork and Attenuation .....	10	<b>Additional Accessories</b> .....	<b>42</b>
Ventilation Air .....	11	Motorized Isolation Valve and Relay .....	42
<b>Electrical</b> .....	<b>12</b>	Pump Restart Relay Kit P/N 061419001 .....	42
Electrical Data .....	12	Multiple Unit Control (Up to 3 Units) (P/N 056794201) .....	42
<b>Unit Installation</b> .....	<b>13</b>	<b>Maintenance</b> .....	<b>43</b>
Piping .....	13	The In and Outs of R-410A .....	43
Cleaning and Flushing System .....	14	Lubrication .....	43
<b>Start-Up</b> .....	<b>15</b>	Charging .....	43
Information for Initial Start-up .....	15	General Maintenance .....	43
Standard Range Units: .....	16	<b>Troubleshooting</b> .....	<b>44</b>
<b>Controls</b> .....	<b>17</b>	MicroTech III Unit Controller LED Faults .....	44
MicroTech® III Unit Controller .....	17	I/O Expansion Module LED Faults (For Units with Optional Boilerless Electric Heat) .....	45
MicroTech III Controller With LONWORKS® Communication Module .....	22	<b>Typical Refrigeration Cycles</b> .....	<b>49</b>
MicroTech III Controller with BACnet® Communication Module .....	23	Cooling Refrigeration Cycle .....	49
Changing PSC Fan Motor Speed .....	25	Heating Refrigeration Cycle .....	49
Factory Fan Speed Settings .....	29	<b>General Use and Information</b> .....	<b>50</b>
Fan Speed Selector Switch .....	30	Water Source Heat Pump Equipment Check, Test and Start Form .....	51
Fan Performance For Optional Constant Torque EC Motor (Sizes 007–012) .....	30		
Fan Performance For Optional Constant CFM EC Motor (Sizes 015–070) .....	31		

## Hazard Identification Information

 **WARNING**

This Installation and Maintenance bulletin is intended to provide the proper procedures for installing a Daikin Water Source Heat Pump. Failure to follow these procedures can cause property damage, severe personal injury or death. Additional, failure to follow these procedures can cause premature failure of this equipment or cause erratic unit operation, resulting in diminished unit performance. Disregarding these directions may further lead to suspension or revocation of the manufacturer's warranty.

 **DANGER**

Dangers indicate a hazardous situation, which will result in death or serious injury if not avoided.

 **CAUTION**

Cautions indicate potentially hazardous situations, which can result in personal injury or equipment damage if not avoided.

 **WARNING**

Warnings indicate potentially hazardous situations, which can result in property damage, severe personal injury, or death if not avoided.

**Note:** *Indicates important details or clarifying statements for information presented.*

Category	Code Item	Code Option	Code Designation & Description
<b>Product Category</b>	<b>01</b>	<b>1</b>	W = Water Source Heat Pump
<b>Product Identifier</b>	<b>02</b>	<b>2-4</b>	CCH = R410A, Ceiling-Mounted, Standard Range CCW = R410A, Ceiling-Mounted, Geothermal Range
<b>Design Series (Vintage)</b>	<b>03</b>	<b>5</b>	4 = D Design 5 = E Design
<b>Nominal Capacity</b>	<b>04</b>	<b>6-8</b>	007 = 7,000 Btuh Nominal Cooling 009 = 9,000 Btuh Nominal Cooling 012 = 12,000 Btuh Nominal Cooling 015 = 15,000 Btuh Nominal Cooling 019 = 19,000 Btuh Nominal Cooling 024 = 24,000 Btuh Nominal Cooling 030 = 30,000 Btuh Nominal Cooling 036 = 36,000 Btuh Nominal Cooling 042 = 42,000 Btuh Nominal Cooling 048 = 48,000 Btuh Nominal Cooling 060 = 60,000 Btuh Nominal Cooling 070 = 70,000 Btuh Nominal Cooling
<b>Controls</b>	<b>05</b>	<b>9</b>	S = Microtech III Unit Controller H = Microtech III Controller with LonWORKS Comm Module J = Microtech III Controller with BACnet Comm Module
<b>Voltage</b>	<b>06</b>	<b>10</b>	A = 115-60-1 (Sizes 007- 009 only) E = 208-230/60/1 J = 265/277-60-1 F = 208-230/60/3 K = 460/60/3* L = 575/60/3 M = 230/50/1 N = 380/50/3
<b>Return Air</b>	<b>08</b>	<b>12</b>	L = Left R = Right
<b>Discharge Air</b>	<b>09</b>	<b>13</b>	E = End Discharge S = Straight Discharge
<b>Blower Motor</b>	<b>10</b>	<b>14-15</b>	01 = Standard PSC 03 = Low Static 14 = ECM
<b>Construction Type</b>	<b>12</b>	<b>18</b>	A = Standard (1/2 inch FG insulation /1" filter rack) B = Standard with 2" Filter Rack C = Standard with Compressor Sound Blanket D = Standard with Compressor Sound Blanket and 2" filter rack E = Indoor Air Quality (IAQ) - Closed Cell Insulation F = IAQ with 2" Filter Rack G = IAQ with Compressor Sound Blanket H = IAQ with Compressor Sound Blanket and 2" Filter Rack J = Sound Package K = Sound Package w/2" Filter Rack
<b>Heat Exchanger</b>	<b>13</b>	<b>19</b>	C = Copper Inner Tube - Steel Outer Tube S = Cupronickel Inner Tube - Steel Outer Tube
<b>Drain Pan</b>	<b>19</b>	<b>30-32</b>	YYY = Standard (Corrosion Resistant Polypropylene) Drain Pan SYY = Stainless Steel Drain Pan
<b>Refrigerant</b>	<b>20</b>	<b>33</b>	A = R410A
<b>Cabinet Electrical</b>	<b>22</b>	<b>35-37</b>	YYY = Standard (50VA Transformer) 75VA = 75VA Control Transformer
<b>Color</b>	<b>24</b>	<b>39</b>	Y = None (Galvanized)
<b>Agency Listing</b>	<b>26</b>	<b>41</b>	C = ETL, CETL, ARI, MEA
<b>Packaging</b>	<b>27</b>	<b>42</b>	1 = Standard
<b>Product Style</b>	<b>29</b>	<b>44</b>	1 = Style

Notes: \* A 460 volt, 3-phase unit that utilize an ECM fan motor will need a 4-wire WYE voltage supply with 3 hot leads and a neutral wire. To power the EC motor with neutral and one hot for 277/60/1 voltage to the EC motor.



## Receiving and Storage

### CAUTION

Sharp edges can cause personal injury. Avoid contact with them. Use care and wear protective clothing, safety glasses and gloves when handling parts and servicing heat pumps.

Upon receipt of the equipment, check carton for visible damage. Make a notation on the shipper's delivery ticket before signing. If there is any evidence of rough handling, immediately open the cartons to check for concealed damage. If any damage is found, notify the carrier within 48 hours to establish your claim and request their inspection and a report. The Warranty Claims Department should then be contacted.

Do not stand or transport the machines on end. For storing, each carton is marked with "up" arrows.

In the event that elevator transfer makes up-ended positioning unavoidable, do not operate the machine until it has been in the normal upright position for at least 24 hours.

Temporary storage at the job site must be indoor, completely sheltered from rain, snow, etc. High or low temperatures naturally associated with weather patterns will not harm the units. Excessively high temperatures, 140°F (60°C) and higher, may deteriorate certain plastic materials and cause permanent damage.

### IMPORTANT

This product was carefully packed and thoroughly inspected before leaving the factory. Responsibility for its safe delivery was assumed by the carrier upon acceptance of the shipment. Claims for loss or damage sustained in transit must therefore be made upon the carrier as follows:

#### VISIBLE LOSS OR DAMAGE

Any external evidence of loss or damage must be noted on the freight bill or carrier's receipt, and signed by the carrier's agent. Failure to adequately describe such external evidence of loss or damage may result in the carrier's refusal to honor a damage claim. The form required to file such a claim will be supplied by the carrier.

#### CONCEALED LOSS OR DAMAGE

Concealed loss or damage means loss or damage which does not become apparent until the product has been unpacked. The contents may be damaged in transit due to rough handling even though the carton may not show external damages. When the damage is discovered upon unpacking, make a written request for inspection by the carrier's agent within fifteen (15) days of the delivery date and file a claim with the carrier.

### CAUTION

The installer must determine and follow all applicable codes and regulations. This equipment presents hazards of electricity, rotating parts, sharp edges, heat and weight. Failure to read and follow these instructions can result in property damage, severe personal injury or death. This equipment must be installed by experienced, trained personnel only.

## Pre-Installation

1. To prevent damage, do not operate this equipment for supplementary heating and cooling during the construction period.
2. Inspect the carton for any specific tagging numbers indicated by the factory per a request from the installing contractor. At this time the voltage, phase and capacity should be checked against the plans.
3. Check the unit size against the plans to verify that the unit is being installed in the correct location.
4. Before installation, check the available ceiling height versus the height of the unit.
5. Note the location and routing of water piping, condensate drain piping, and electrical wiring. The locations of these items are clearly marked on submittal drawings.
6. The installing contractor will find it beneficial to confer with piping, sheet metal, and electrical foremen before installing any unit.

- Notes:**
1. *Check the unit data plate for correct voltage with the plans before installing the equipment. Also, make sure all electrical ground connections are made in accordance with local code*
  2. *When installing a MicroTech III Horizontal unit size 007, 009 or 012 which are provided with a factory-mounted BACnet communication module, it is suggested that the MAC address dip switches on the communication module be set prior to installing the unit in the ceiling. Access to the dip switches may be limited when the unit is installed. Reference IM 928 for addressing methods available.*
  7. The contractor shall cover the units to protect the machines during finishing of the building. This is critical while spraying fireproofing material on bar joists, sandblasting, spray painting and plastering. If plastic film is not available, the shipping carton may be modified to cover the units during construction.
  8. Remove all shipping blocks in the fan wheel.
  9. Change the airflow direction from straight discharge to end discharge or vice versa before the unit is installed in the ceiling. Refer to "[Air Discharge Conversion](#)" on page 8.

## Unit Location

1. Locate the unit in an area that allows for easy removal of the filter and access panels. Leave a minimum of 18" of clearance around the heat pump for easy removal of the entire unit (if necessary), and to perform routine maintenance, or troubleshooting. Provide sufficient room to make water, electrical and duct connections.
2. The contractor should make sure that adequate ceiling panel access exists, including clearance for hanger brackets, duct collars and fittings at water and electrical connections.
3. Allow adequate room below the unit for a condensate trap and do not locate the unit above pipes.
4. Each unit is suspended from the ceiling by four threaded rods. The rods are attached to the unit corners by a hanger bracket through a rubber isolator.

**⚠ CAUTION**

Do not use rods smaller than shown in Figure 1. The rods must be securely anchored to the ceiling or to the bar joists.

5. Each unit is furnished with a hanger kit. The kit is shipped unassembled and includes hanger brackets, rubber isolators, washers, bolts and lock washers. Lay out the threaded rods per the dimension in Figure 2.

**Figure 1: Hanger Bracket Detail - Sizes 007 Through 060**

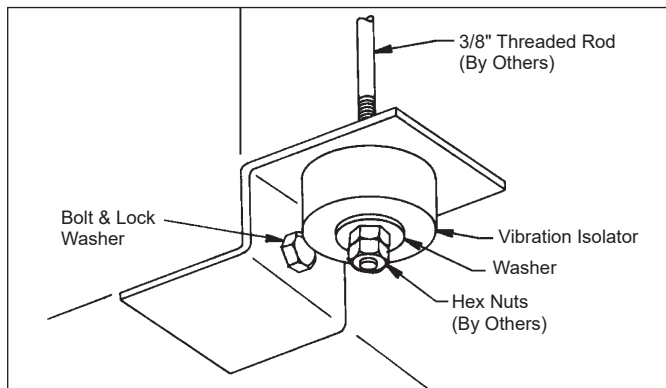

6. When attaching the hanger rods to the unit, a double nut is recommended since vibration could loosen a single nut. The installer is responsible for providing the hex nuts when installing hanger rods.
7. Leave minimum 3" (76 mm) extra threaded rod below the double nuts or minimum 3" (76 mm) clearance between top of unit and ceiling above to facilitate top panel removal for servicing.



**Figure 2: Hanger Bracket Location Dimensions - Sizes 007 Through 060**

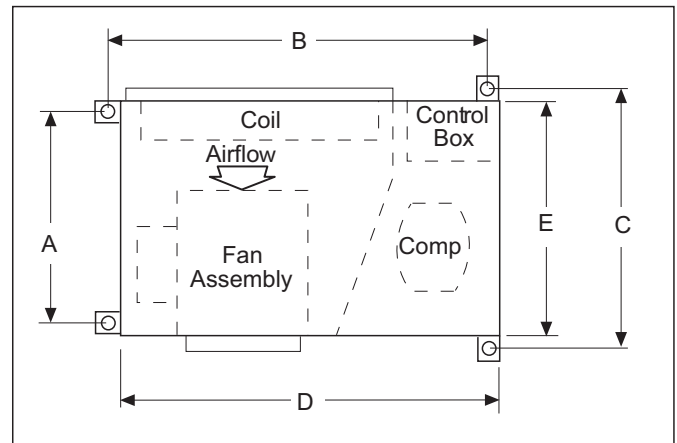

**Table 1: Hanger Bracket Dimensions**

Unit Size	Dimensions - inches (mm)				
	A	B	C	D	E
<b>007 – 009</b>	17.5 (445)	34 (864)	22 (559)	34 (864)	20 (508)
<b>012</b>	17.5 (445)	40 (1016)	22 (559)	40 (1016)	20 (508)
<b>015 – 024</b>	17.5 (445)	42 (1067)	22 (559)	42 (1067)	20 (508)
<b>030 – 036</b>	18.5 (470)	46 (1168)	23 (584)	46 (1168)	21 (533)
<b>042 – 070</b>	25.5 (648)	52 (1321)	30 (762)	52 (1321)	28 (711)



## Filter Access

Each unit is shipped with a filter bracket for side filter removal. For bottom removal push the filter up into top bracket to gain clearance of bottom bracket and remove the filter. Also, a sheet metal duct filter retainer can be fabricated when return air duct work is used.

## Air Discharge Conversion

Unit sizes 007 thru 060 are stocked as straight discharge. A straight discharge unit may be converted to an end discharge by doing the following:

**Note:** *The information covered in this section of the blower assembly orientation is typical of Daikin units. Regardless, if you are changing end to straight or straight to end the blower assembly has to turn 90 degrees and simultaneously rotate 180 degrees to achieve the proper orientation. Not all Daikin units will have the same air discharge location but will have the same general results when following the instructions.*

### **DANGER**



**Hazardous Voltage!**

Disconnect all electric power including remote disconnects before servicing. Failure to disconnect power before servicing can cause severe personal injury or death.

### **CAUTION**

Sharp edges can cause personal injury. Avoid contact with them. Use care and wear protective clothing, safety glasses and gloves when handling parts and servicing heat pumps.

1. Turn off power to the unit at the breaker box.
2. Remove the top panel by removing the screws around the perimeter of the top securing it to the lower cabinet (Figure 4).

**Note:** *Retain all screws for reinstalling.*

3. Remove the access panel to the fan motor by loosening the two (2) screws at the bottom holding the panel (Figure 4). Remove the piece of insulation at the bottom on the side of the bottom panel.
4. If the unit being converted is installed and has been operating, discharge the capacitor. Release the wire clip shown in Figure 3 to provide slack in the wires. If necessary remove the wire tie to provide additional free wire length.

**Figure 3: Discharge Capacitor and Release Wire Clip**

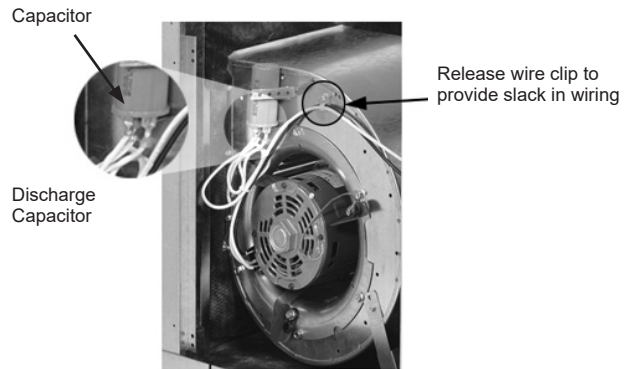

5. Remove the screws securing the fan discharge panel assembly (Figure 4).

**Figure 4: Remove Top and Access Panel to Fan Motor**

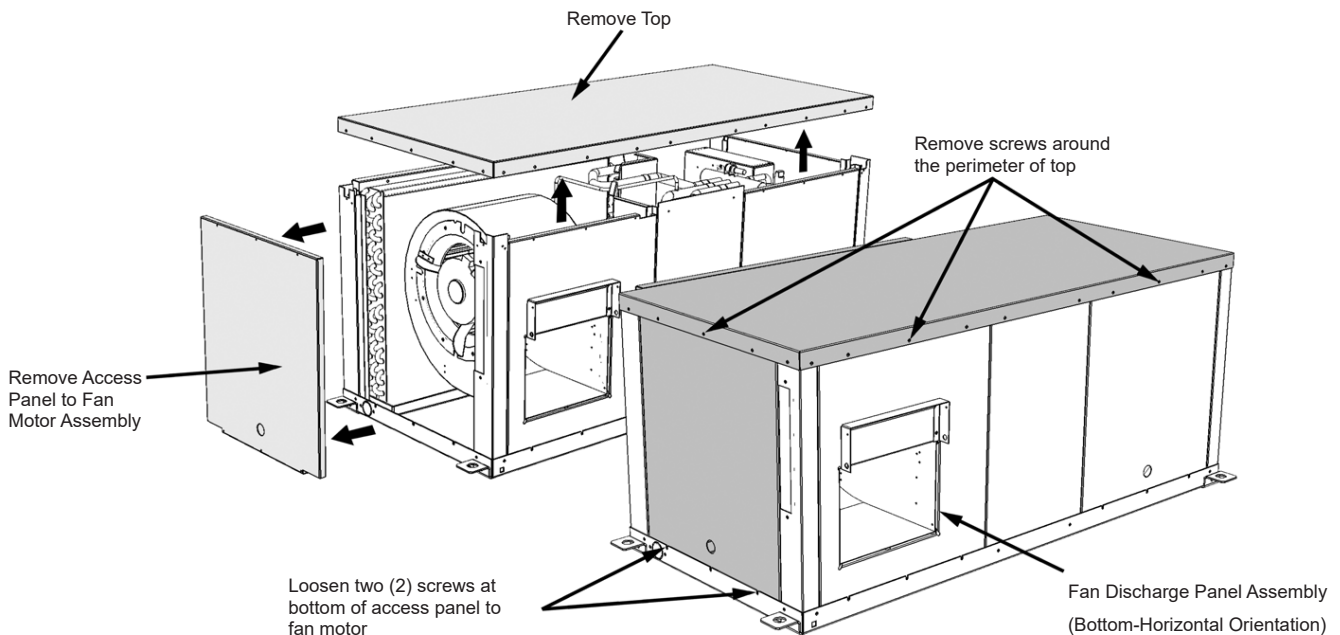



6. Lift the fan assembly out rotating it 180 degrees and position it within the opening at the end of the unit (Figure 5). With the fan motor in the end discharge position the fan and housing orientation is top-horizontal. A straight air discharge arrangement, the housing is in the bottom-horizontal orientation.
  7. Secure the fan assembly to the unit frame with the screws removed previously.
  8. Reinstall the access panel in the fan motor access opening (Figure 6).
  9. Reinstall the top panel and secure with screws removed previously.
- Note:** *If installed correctly the fan motor should be accessible when the fan motor access panel is removed.*

**Figure 5: Lift Out the Fan Assembly, Turn 90 Degrees and Rotate 180 Degrees**

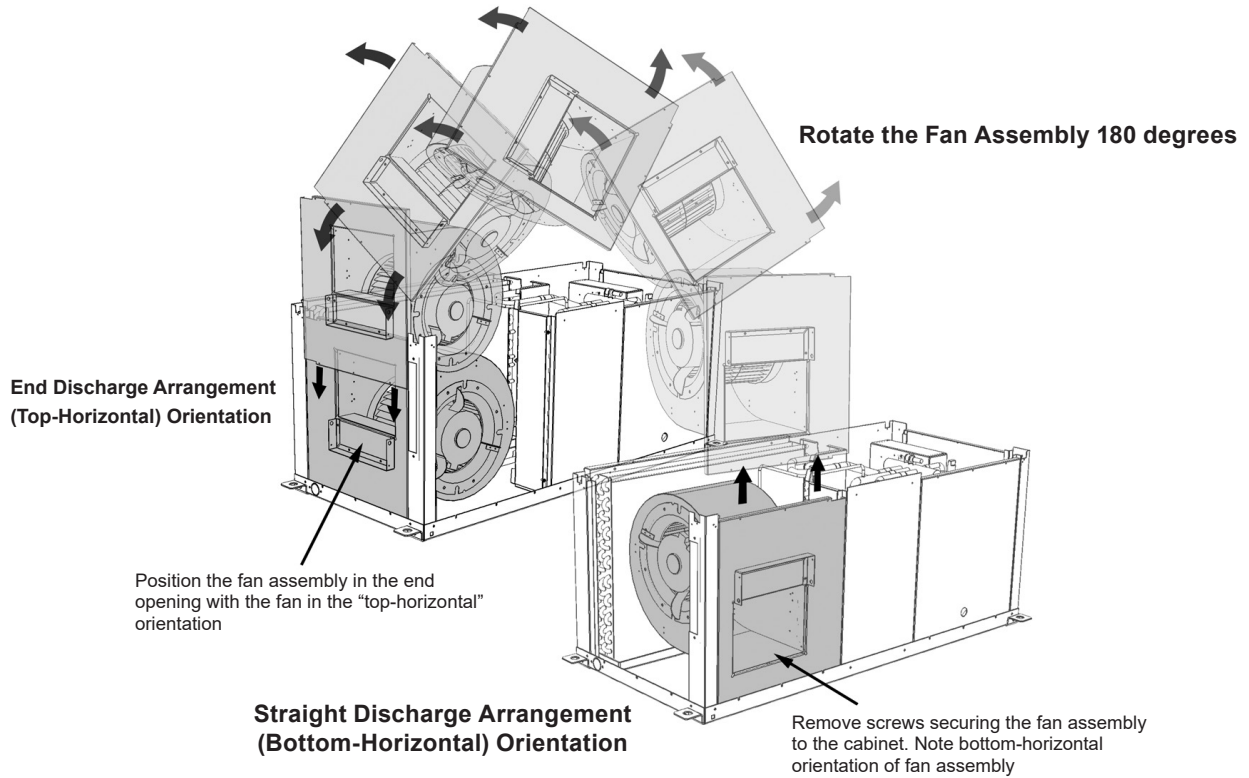

**Figure 6: Reinstall the Top and Access Panel**

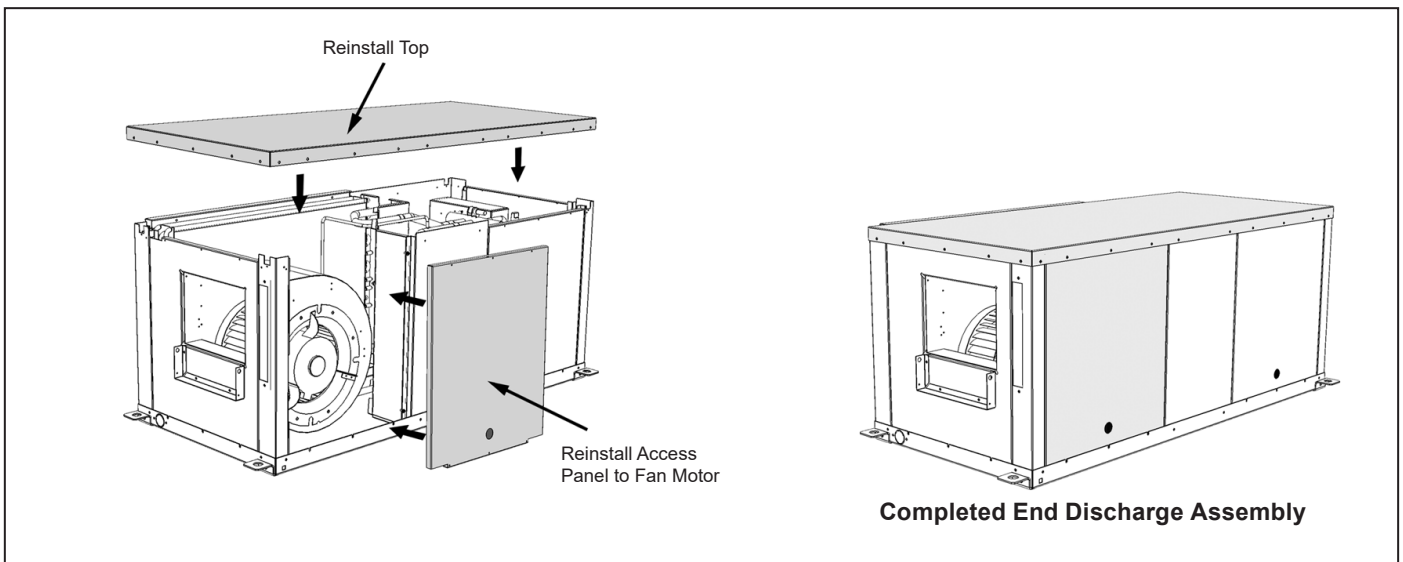

## Ductwork and Attenuation

Discharge ductwork is normally used with these conditioners. Return air ductwork may also be required.

All ductwork should conform to industry standards of good practice as described in the ASHRAE Systems Guide.

The discharge duct system will normally consist of a flexible connector at the unit, a transition piece to the full duct size, a short run of duct, an elbow without vanes, and a trunk duct teeing into a branch duct with discharge diffusers as shown in Figure 7. The transition piece must not have angles totaling more than 30 degrees or severe loss of air performance can result.

Do not connect the full duct size to the unit without using a transition piece down to the size of the discharge collar on the unit. With metal duct material, the sides only of the elbow and entire branch duct should be internally lined with acoustic fibrous insulation for sound attenuation. Glass fiber duct board material is more absorbing and may permit omission of the canvas connector.

As a general recommendation, the acoustic fibrous insulation should be at least 1/2-inch thick over the entire duct run (Figure 8). For better sound attenuation,

line the last five diameters of duct before each register with a one-inch thick sound blanket. Elbows, tees and dampers can create turbulence or distortion in the airflow. Place a straight length of duct, 5 to 10 times the duct width, before the next fitting to smooth out airflow. Diffusers that are located in the bottom of a trunk duct can also produce noise. For this same reason, volume control dampers should be located several duct widths upstream from an air outlet.

For Hotel, Motel, Dormitory or Nursing Home applications that use a single duct discharge, a velocity of 500 to 600 fpm is suggested. These applications typically have static pressures as low as 0.05 inches of water and duct lengths approximately six feet in length. The discharge duct must be fully lined and have a square elbow without turning vanes. Return air for these applications should enter through a "low" sidewall filter grille and route up the stud space to a ceiling plenum. For horizontal heat pumps mounted from the ceiling, an insulated return plenum is sometimes placed at the return air opening to further attenuate line-of-sight sound transmission through return openings.

**Figure 7: Suggested Supply Ducting Per ASHRAE and SMACNA Publications**

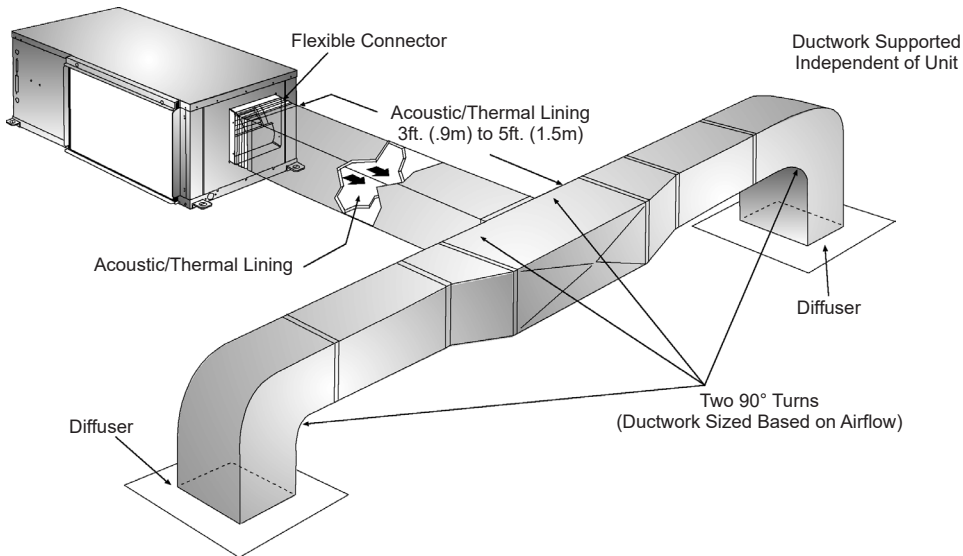

**Figure 8: Suggested Return Ducting Per ASHRAE and SMACNA Publications**

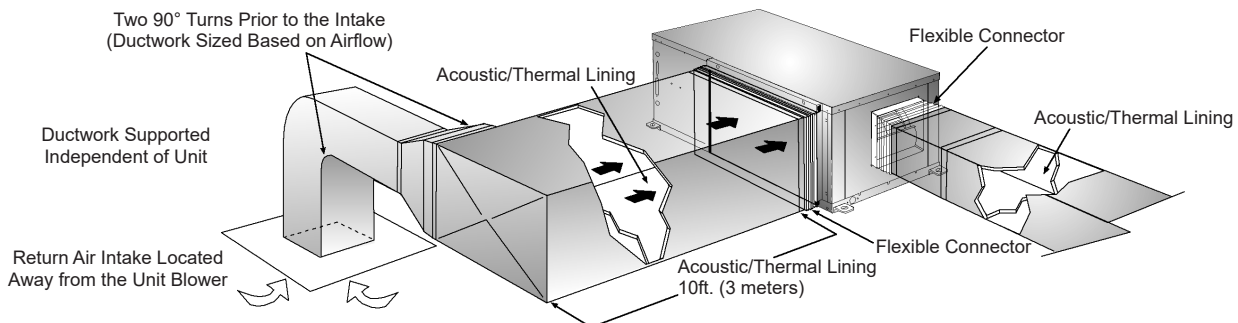

Return air ductwork can be connected to the standard filter rack. See [Figure 9](#) (side filter removal shown). The filter rack can be installed for bottom filter removal or side filter removal by locating the brackets. For side filter removal the brackets should be located on the bottom, left side, and top. For bottom filter removal the brackets should be mounted on the left side top and right side with the spring clips supporting the filter.

Do not use sheet metal screws directly into the unit cabinet for connection of supply or return air ductwork, especially return air ductwork which can hit the drain pan or the air coil.

**Figure 9: Standard 1" (25mm) Filter Rack/Return Air Duct Collar**

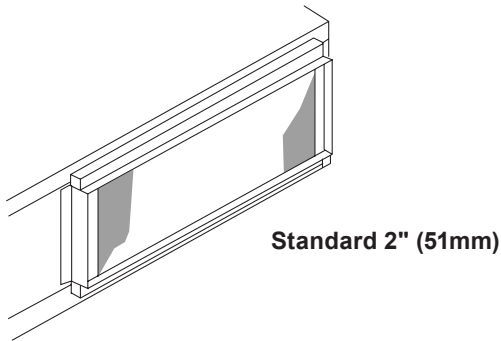

**Figure 10: Optional 2" (51mm) Filter Rack/Return Air Duct Collar**

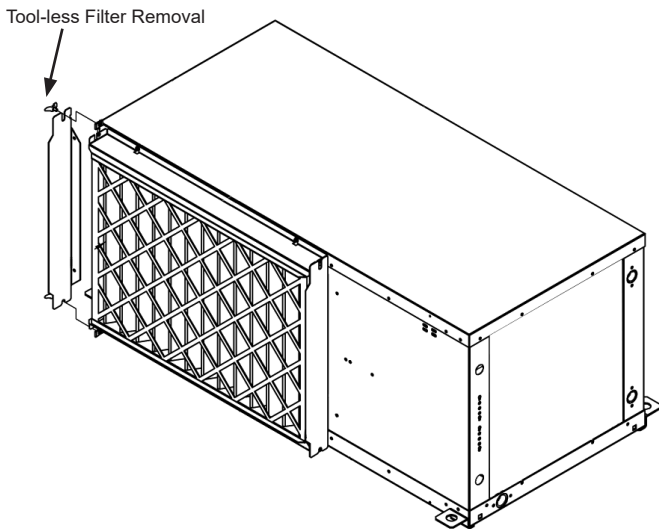

## Ventilation Air

Ventilation may require outside air. The temperature of the ventilation air must be controlled so that mixture of outside air and return air entering the conditioner does not exceed conditioner application limits. It is also typical to close off the ventilation air system during unoccupied periods (night setback).

The ventilation air system is generally a separate building subsystem with distribution ductwork. Simple introduction of the outside air into each return air plenum chamber reasonably close to the conditioner air inlet is recommended. Do not duct outside air directly to the conditioner inlet. Provide sufficient distance for thorough mixing of outside and return air. See ["Operating Limits"](#) on page 16.

## Electrical Data

### General

1. Verify the compatibility between the voltage and phase of the available power and that shown on the unit serial plate. Line and low voltage wiring must comply with local codes or the National Electrical Code, whichever applies.
2. Apply correct line voltage to the unit. A 7/8" (22mm) hole and/or a 1-1/8" (29 mm) knockout is supplied on the side of the unit. A disconnect switch near the unit is required by code. Power to the unit must be sized correctly and have dual element (Class RK5) fuses or an HACR circuit breaker for branch circuit overcurrent protection. See the nameplate for correct ratings.
3. Three phase 50 cycle units, 380/50-3, require a neutral wire for 230/50-1 power to the fan circuit.
4. Connect the thermostat/subbase wiring with the power "off" to the unit.
5. Field supplied relays installed on the input terminals W1, W2, Y1, Y2 or G may introduce electrical noise. Never install relay coils in series with the inputs.

### 230 Volt Operation

All 208-230 volt single-phase and three-phase units are factory wired for 208 volt operation. For 230 phase operation, the line voltage tap on the 24 volt transformer must be changed. Disconnect and cap the red lead wire and interchange it with the orange lead wire on the primary of the 24 volt transformer (sizes 007-060).

### Fan Assembly

All fan motors are multi-speed PSC or optional ECM type with integral mounting brackets and thermal overload protection. The motor is isolated from the fan housing for minimum vibration transmission. PSC Fan motors have a terminal strip on the motor body for simple motor speed change without going back to the control box. To change fan motor speed refer to "[Changing PSC Fan Motor Speed](#)" on page 25.

All the fan/motor assemblies have a removable orifice ring on the housing to accommodate motor and fan wheel removal without disconnecting the ductwork. The fan housing protrudes through the cabinet allowing adequate material for connection of flexible duct. Each model unit is shipped from the factory for maximum performance and minimum sound requirements. Fan sound levels and performance can be affected by external static pressure.

## Piping

1. All units should be connected to supply and return piping in a two-pipe reverse return configuration. A reverse return system is inherently self-balancing and requires only trim balancing where multiple quantities of units with different flow and pressure drop characteristics exist in the same loop. Check for proper water balance by measuring differential temperature reading across the water connections. To insure proper water flow, the differential flow should be 10°F to 14°F (5°C to 8°C) for units in cooling mode. A direct return system may also work acceptably, but proper water flow balancing is more difficult to achieve and maintain.
2. The piping must comply with local codes.

### ⚠ WARNING

Polyolester Oil, commonly known as POE oil is a synthetic oil used in many refrigeration systems, and may be present in this Daikin product. POE oil, if ever in contact with PVC/CPVC will coat the inside wall of PVC/CPVC pipe causing environmental stress fractures. Although there is no PVC/CPVC piping in this product, please keep this in mind when selecting piping materials for your application, as system failure and property damage could result.

3. Supply and return runouts usually join the unit via short lengths of high pressure flexible hose which are sound attenuators for both unit operating noise and hydraulic pumping noise. One end of the hose should have a swivel fitting to facilitate removal for service. Hard piping can also be brought directly to the unit. This option is not recommended since no vibration or noise attenuation can be accomplished. The hard piping must have unions to facilitate unit removal. See Figure 11 for typical piping setup.
4. Some flexible hose threaded fittings are supplied with sealant compound. If not, apply Teflon tape to assure a tight seal.

Figure 11: Sizes 007 Through 060 Shown

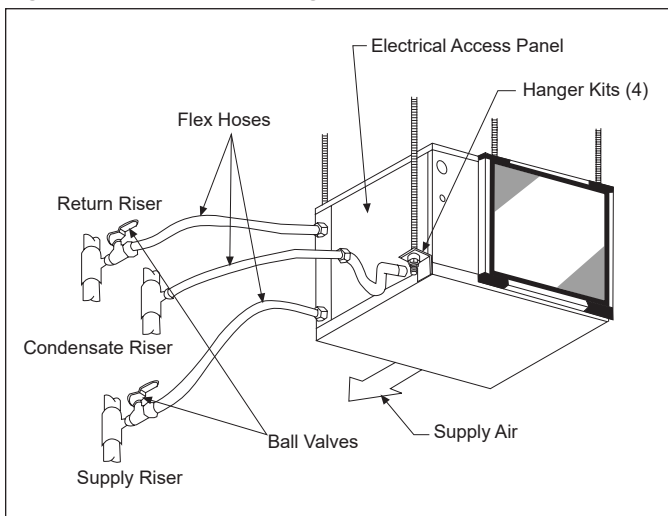

- Note:** Do not over-torque fittings. The maximum torque without damage to fittings is 30 foot pounds. If a torque wrench is not available, use as a rule of thumb, finger tight plus one quarter turn.
5. Supply and return shutoff valves are required at each conditioner. The return valve is used for balancing and should have a “memory stop” so that it can always be closed off but can only be reopened to the proper position for the flow required.
  6. No unit should be connected to the supply and return piping until the water system has been cleaned and flushed completely. After the cleaning and flushing has taken place, the initial connection should have all valves wide open in preparation for water system flushing.
  7. Condensate piping should be installed per local codes. Each unit includes a condensate connection.
  8. The condensate disposal piping must be trapped. The piping must be pitched away from the unit not less than 1/4" per foot. The unit has a 3/4 inch female pipe fitting on each water source heat pump to accommodate the condensate drain connection. Factory supplied condensate hose assemblies have a pipe thread fitting to facilitate connection of a flexible vinyl or steel braided hose. Union fittings in the field provided condensate lines should be applied to facilitate removal.

Figure 12: Condensate Disposal Trapping Detail

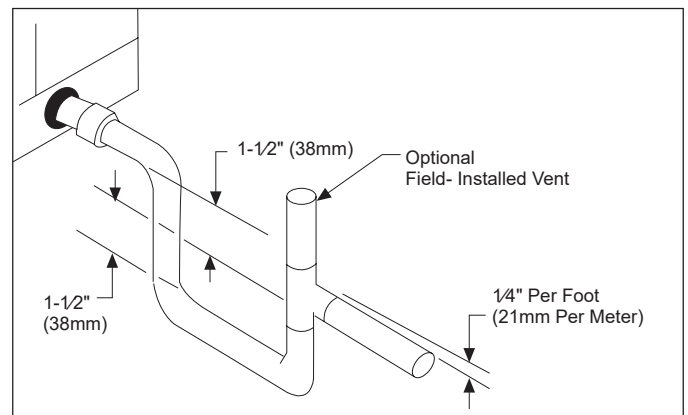

9. Do not locate any point in the drain system above the drain connection of any unit.
10. Automatic flow controlled devices must not be installed prior to system cleaning and flushing.
11. A high point of the piping system must be vented.
12. Check local code for the need for dielectric fittings.



## Cleaning and Flushing System

1. Prior to first operation of any conditioner, the water circulating system must be cleaned and flushed of all construction dirt and debris. If the conditioners are equipped with water shutoff valves, either electric or pressure operated, the supply and return runouts must be connected together at each conditioner location. This will prevent the introduction of dirt into the unit. See Figure 13.

**Figure 13: Supply and Return Runouts Connected Together**

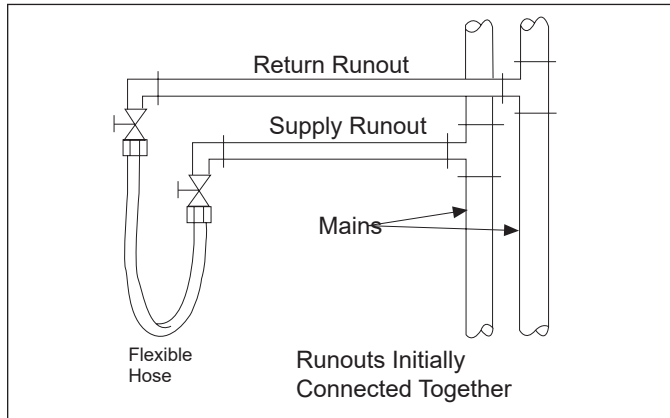

2. Fill the system at the city water makeup connection with all air vents open. After filling, close all air vents. The contractor should start main circulator with the pressure reducing valve open. Check vents in sequence to bleed off any trapped air, ensuring circulation through all components of the system. Power to the heat rejector unit should be off, and the supplementary heat control set at 80°F (27°C). While circulating water, the contractor should check and repair any leaks in the piping. Drains at the lowest point(s) in the system should be opened for initial flush and blowdown, making sure city water fill valves are set to make up water at the same rate. Check the pressure gauge at pump suction and manually adjust the makeup to hold the same positive steady pressure both before and after opening the drain valves. Flush should continue for at least two hours, or longer if required, to see clear, clean drain water.

3. Shut off supplemental heater and circulator pump and open all drains and vents to completely drain down the system. Short circuited supply and return runouts should now be connected to the conditioner supply and return connections. Do not use sealers at the swivel flare connections of hoses.
4. Trisodium phosphate was formerly recommended as a cleaning agent during flushing. However, many states and localities ban the introduction of phosphates into their sewage systems. The current recommendation is to simply flush longer with warm 80°F (27°C) water.
5. Refill the system with clean water. Test the water using litmus paper for acidity, and treat as required to leave the water slightly alkaline (pH 7.5 to 8.5). The specified percentage of antifreeze may also be added at this time. Use commercial grade antifreeze designed for HVAC systems only. Do not use automotive grade antifreeze. Once the system has been filled with clean water and antifreeze (if used), precautions should be taken to protect the system from dirty water conditions. Dirty water will result in system wide degradation of performance and solids may clog valves, strainers, flow regulators, etc. Additionally, the heat exchanger may become clogged which reduces compressor service life or causes premature failure.
6. Set the loop water controller heat add setpoint to 70°F (21°C) and the heat rejection setpoint to 85°F (29°C). Supply power to all motors and start the circulating pumps. After full flow has been established through all components including the heat rejector (regardless of season) and air vented and loop temperatures stabilized, each of the conditioners will be ready for check, test and start-up, air balancing, and water balancing.

## Start-Up

1. Open all valves to full open position and turn on power to the conditioner.
2. Set thermostat for "Fan Only" operation by selecting "Off" at the system switch and "On" at the fan switch. If "Auto" fan operation is selected, the fan will cycle with the compressor. Check for proper air delivery.
3. For those units that have two-speed motors, reconnect for low speed operation if necessary.
4. Set thermostat to "Cool." If the thermostat is an automatic changeover type, simply set the cooling temperature to the coolest position. On manual changeover types additionally select "Cool" at the system switch.  
 Again, many conditioners have time delays which protect the compressor(s) against short cycling. After a few minutes of operation, check the discharge grilles for cool air delivery. Measure the temperature difference between entering and leaving water. It should be approximately 1½ times greater than the heating mode temperature difference. For example, if the cooling temperature difference is 15°F (8°C), the heating temperature difference should have been 10°F (5°C).  
 Without automatic flow control valves, target a cooling temperature difference of 10°F to 14°F (5°C to 8°C). Adjust the combination shutoff/balancing valve in the return line to a water flow rate which will result in the 10°F to 14°F (5°C to 8°C) difference.
5. Set thermostat to "Heat." If the thermostat is the automatic changeover type, set system switch to the "Auto" position and depress the heat setting to the warmest selection. Some conditioners have built-in time delays which prevent the compressor from immediately starting. With most control schemes, the fan will start immediately. After a few minutes of compressor operation, check for warm air delivery at discharge grille. If this is a "cold building" start-up, leave unit running until return air to the unit is at least 65°F (18°C).  
 Measure the temperature difference between entering and leaving air and entering and leaving water. With entering water of 60°F to 80°F (16°C to 27°C), leaving water should be 6°F to 12°F (3.3°C to 6.6°C) cooler, and the air temperature rise through the machine should not exceed 35°F (19°C). If the air temperature exceeds 35°F (19°C), then the water flow rate is inadequate.

6. Check the elevation and cleanliness of the condensate line. If the air is too dry for sufficient dehumidification, slowly pour enough water into the condensate pan to ensure proper drainage.
7. If the conditioner does not operate, check the following points:
  - a. Is supply voltage to the machine compatible?
  - b. Is thermostat type appropriate?
  - c. Is thermostat wiring correct?
8. If the conditioner operates but stops after a brief period:
  - a. Is there proper airflow? Check for dirty filter, incorrect fan rotation (3-phase fan motors only), or incorrect ductwork.
  - b. Is there proper water flow rate within temperature limits? Check water balancing; backflush unit if dirt-clogged.
9. Check for vibrating refrigerant piping, fan wheels, etc.
10. Do not lubricate the fan motor during the first year of operation as it is pre-lubricated at the factory.
11. Field supplied relays installed on the input terminals W1, W2, Y1, Y2 or G may introduce electrical noise. Never install relay coils in series with the inputs.

## Information for Initial Start-up

### CAUTION

Units must be checked for water leaks upon initial water system start-up. Water leaks may be a result of mishandling or damage during shipping. Failure by the installing contractor to check for leaks upon start-up of the water system could result in property damage.

## Check, Test and Start Procedure

### NOTICE

Complete the "Water Source Heat Pump Equipment Check, Test and Start Form" beginning on [page 51](#).



## Typical Water Source Heat Pump Common Design Temperatures

**Table 2: Typical Water Source Heat Pump Common Design Temperatures**

Operating Mode	Entering Air °F				Entering Water °F			
	Minimum		Maximum		Standard Range		Extended Range	
	DB	WB	DB	WB	Minimum	Maximum	Minimum	Maximum
Cooling	75	63	80	67	85	100	85	100
Heating	60	–	70	–	60	70	40	70

## Water Source Heat Pump Operating Temperature Limits (For Continuous Duty)

**Table 3: Water Source Heat Pump Operating Temperature Limits (For Continuous Duty)**

Operating Mode	Entering Air °F				Entering Water °F			
	Minimum		Maximum		Standard Range		Extended Range	
	DB	WB	DB	WB	Minimum	Maximum	Minimum	Maximum
Cooling	65	55	85	71	55	110	50	110
Ambient	50	–	100	–	–	–	–	–
Heating	50	–	80	–	55	90	20	90
Ambient	50	–	85	–	–	–	–	–

**Notes:** In the heating mode, the sum of the entering air + entering water must be  $\geq 100^{\circ}\text{F}$ . MINIMUM WATER FLOW = 1.5 GPM/Ton. Maximum and minimum values may not be combined. If one value is at maximum or minimum, the other two conditions may not exceed the normal condition for standard units. Extended range units may combine any two maximum conditions, but not more than two, with all other conditions being normal conditions.

## Water Source Heat Pump Operating Temperature Limits at Start-Up (Not for Continuous Duty)

**Table 4: Water Source Heat Pump Operating Temperature Limits at Start-Up (Not for Continuous Duty)**

Operating Mode	Entering Air °F				Entering Water °F			
	Minimum		Maximum		Standard Range		Extended Range	
	DB	WB	DB	WB	Minimum	Maximum	Minimum	Maximum
Cooling	50	40	105	87	45	120	30	120
Ambient	45	–	110	–	–	–	–	–
Heating	40	–	85	–	40	95	20	100
Ambient	40	–	85	–	–	–	–	–

### Standard Range Units:

Units are designed to start in an ambient of 50°F (10°C) with entering air at 50°F (10°C), with entering water at 50°F (10°C), with nominal air flow and water flow (3.0 GPM/Ton), for initial start-up in heating.

**Note:** This is not a normal or continuous operating condition. It is assumed that such start-up is for the purpose of bringing the building space up to occupancy temperature.

### Geothermal Range Units:

Units are designed to start in an ambient of 40°F (5°C) with entering air at 40°F (5°C), with entering water at 20°F (-7°C), with nominal air flow and water flow (3.0 GPM/Ton), for initial start-up in heating.

**Note:** This is not a normal or continuous operating condition. It is assumed that such start-up is for the purpose of bringing the building space up to occupancy temperature.

### Environment

This equipment is designed for indoor installation only. Sheltered locations such as attics, garages, etc., generally will not provide sufficient protection against extremes in temperature and/or humidity, and equipment performance, reliability, and service life may be adversely affected.

### Power supply

A voltage variation of +/-10% of nameplate voltage is acceptable. Three-phase system imbalance shall not exceed 2%.

## MicroTech® III Unit Controller

The MicroTech III Unit Controller includes built-in features such as random start, compressor time delay, shutdown, condensate overflow protection, defrost cycle, brownout, and LED/fault outputs. Refer to "[MicroTech III Controller Status LED's](#)" on page 20.

The unit has been designed for operation with a microelectronic wall thermostat selected by the manufacturer. Do not operate the unit with any other type of wall thermostat.

Each unit has a printed circuit board control system. The low voltage output from the low voltage terminal strip is AC voltage to the wall thermostat. R is A/C voltage output to the wall stat.

The 24 volt low voltage terminal strip is set up so R-G energizes the fan, R-Y1 energizes the compressor for cooling operation, R-W1 energizes the compressor and reversing valve for heating operation. The reversing valve is energized in the heating mode. The circuit board has a fan interlock circuit to energize the fan whenever the compressor is on if the thermostat logic fails to do so.

The output to the wall stat is AC current. Terminal (R) on the wall stat can be connected to terminal (R) on the PC board for AC voltage.

**R** = AC current      **R to G** = fan only

**R to Y1** = cooling      **R to W1** = heat

The MicroTech III unit controller has a lockout circuit to stop compressor operation if any one of its safety switches opens (high pressure switch and low pressure switch. If compressor low suction temperature is detected, the unit will go into the cooling mode for 60 seconds to defrost any slush in the water-to-refrigerant heat exchanger. If the condensate sensor detects a filled drain pan, the compressor operation will be suspended only in the cooling mode. The unit is reset by opening and closing the disconnect switch on the main power supply to the unit in the event the unit compressor operation has been suspended due to low temperature (freezestat) switch, high pressure switch, or low pressure switch. The unit does not have to be reset on a condensate overflow detection.

The MicroTech III unit controller fault output sends a signal to an LED on a wall thermostat. [Table 7 on page 20](#) lists the faults that cause the Alarm "A" terminal output to indicate an alarm condition exists.

## Remote Reset of Automatic Lockouts

The Remote Reset feature provides the means to remotely reset some lockouts.

There are (3) means to reset an automatic lockout condition:

1. Using the thermostat create 2 demands for capacity within 30 seconds
2. Press the room sensor or thermostat timed override/ reset button for more than 10 seconds
3. Turn the unit power off

When the cause of the fault condition has been cleared, and the unit transitions from not requiring any capacity to needing any capacity twice within 30 seconds (accomplished by user manipulation of the Heat/Cool/ Auto/Off switch on the thermostat), an alarm reset equivalent to a tenant override button reset is generated. The intelligent reset counter and the 24 hour timer are cleared when this type of alarm reset is generated.

**Note:** *This feature only applies to thermostat controlled systems.*

For room sensor controlled units, pressing the "Override" or "Reset" button for more than 10 seconds will apply a ground signal to the tenant override in (screw terminal connection at TB1 pin 4) will clear the lockout alarm once the cause of the fault condition has been cleared.

A unit power cycle can also be used to clear an automatic lockout if the conditions causing the fault have been cleared.

The Intelligent Alarm Reset feature helps to minimize nuisance trips of automatic reset lockouts caused by low temperature faults. This feature clears faults the first two times they occur within a 24-hour period and triggers an automatic lockout on the 3rd fault. The retry count is reset to zero every 24 hours.

The MicroTech III unit controller has built-in night setback operation. A "grounded" signal to the "U" terminal on TB3 of the unit control puts the unit into the unoccupied mode for night setback operation. Fan operation terminates and unit control will only respond to signal at the W2 terminal. Daytime heating and cooling operation is locked out. +24VAC to W2 energizes the compressor and reversing valve for heating operation. Night setback operation can be overridden for two hours by energizing the O on the TB2 terminal of the unit control for 4 to 10 seconds. Day thermostat setpoints then control the heating and cooling operation. The MicroTech III unit controller also accommodates shutdown operation on receipt of a "grounded" signal to the "E" input, respectively, on TB3 input terminal of the unit control.

**Table 5: MicroTech III SmartSource Unit Controller Terminals and Descriptions**

H1 - 1	24	24 VAC Power Input
H1 - 2	C	24 VAC common
H2 - 1	SL1	Fan Main Required Output – Switched L1
H2 - 2		Blank Terminal
H2 - 3	N	Fan Main Required Output – Neutral
H3 - 1	HP1-1	Comp High Pressure Switch (HP1) Input Terminal 1
H3 - 2	HP1-2	Comp High Pressure Switch (HP1) Input Terminal 2
H4 - 1	1	Discharge Air Temp Sensor – Common
H4 - 2		Discharge Air Temp Sensor – Signal
H4 - 3		Leaving Water Temp Sensor – Common
H4 - 4		Leaving Water Temp Sensor – Signal
H5 - 1	1	Connections to I/O Expansion Board
H5 - 2		
H5 - 3		
H5 - 4		
H5 - 5		
H5 - 6		
H5 - 7		
H5 - 8		
H5 - 9		
H5 - 10		
H5 - 11		
H5 - 12		
H6 - 1	1	Condensate Overflow Signal Input
H6 - 2		Compressor Suction Temp Sensor (LT1) – Common
H6 - 3		Compressor Suction Temp Sensor (LT1) – Signal
H6 - 4		Compressor Low Pressure Switch (LP1) – Source Voltage
H6 - 5		Compressor Low Pressure Switch (LP1) – Signal
H6 - 6		Reversing Valve – Common
H6 - 7		Reversing Valve – Output
H7 - 1	1	No Connection
H7 - 2		No Connection
H7 - 3		Red LED Output
H7 - 4		Green LED Output
H7 - 5		Yellow LED Output
H7 - 6		Red-Green-Yellow LED Common
H8 - 1	1	Isolation Valve/Pump Request Relay N/O
H8 - 2		Isolation Valve/Pump Request Relay N/C
H8 - 3		24 VAC Common
H9 - 1	1	Return Air Sensor – Signal
H9 - 2		Return Air Sensor – Common
TB1 - 1	1	Room Sensor – Status LED Output
TB1 - 2	2	Room Sensor – Fan Mode & Unit Mode Switches
TB1 - 3	3	Room Sensor – Setpoint Adjust Potentiometer
TB1 - 4	4	Room Sensor – Room Temp Sensor & Tenant Override
TB1 - 5	5	Room Sensor – DC Signal Common
TB2 - 1	R	24 VAC
TB2 - 2	A	Thermostat – Alarm Output
TB2 - 3	W2	Thermostat – Heat Stage #2 (W2) Input
TB2 - 4	W1	Thermostat – Heat Stage #1 (W1) Input
TB2 - 5	Y2	Thermostat – Cool Stage #2 (Y2) Input
TB2 - 6	Y1	Thermostat – Cool Stage #1 (Y1) Input
TB2 - 7	G	Thermostat – Fan Input
TB2 - 8	O	Thermostat – Heat Stage #3 (W3) Input

TB2 - 9	C	24 VAC Common
TB3 - 1	E	Emergency Shutdown Input
TB3 - 2	U	Unoccupied Input
L1 - 1	L1 - 1	Line Voltage Terminal 1
L1 - 2	L1 - 2	Line Voltage Terminal 2
L1 - 3	L1 - 3	Line Voltage Terminal 3
N1	N1	Neutral Terminal 1
N2	N2	Neutral Terminal 2
N3	N3	Neutral Terminal 3

**I/O Expansion Module Connectors/Terminals**

H1 - 1	1	Connections to Main Board
H1 - 2		
H1 - 3		
H1 - 4		
H1 - 5		
H1 - 6		
H1 - 7		
H1 - 8		
H1 - 9		
H1 - 10		
H1 - 11		
H1 - 12		
H2 - 1	1	Auxiliary Heat Stage #2 Output – N/O
H2 - 2		No Connection
H2 - 3		24 VAC Common
H3 - 1	1	Ext. 24 VAC In
H3 - 2		Ext. 24 VAC Common In
H3 - 3		HGR / Waterside Economizer Output – N/O
H3 - 4		Ext. 24 VAC Common
H3 - 5		ECM Fan Motor Variable Speed Signal Output
H3 - 6		ECM Fan Motor Variable Speed Signal – Common
H4 - 1	1	Entering Water Temp Sensor – Signal
H4 - 2		Entering Water Temp Sensor – Common
H5 - 1	1	No Connection
H5 - 2		No Connection
H5 - 3		Red LED Output
H5 - 4		Green LED Output
H5 - 5		Yellow LED Output
H5 - 6		Red-Green-Yellow LED Common
H6 - 1	HP2-1	Jumper Wire Connection
H6 - 2	HP2-2	Jumper Wire Connection
H7 - 1		Fan Speed Table Row Select – Signal
H7 - 2		Fan Speed Table Row Select – Common
H7 - 3		Thermostat – Heat Stage #4 (W4) Input – Signal
H7 - 4		Auxiliary 24 VAC Out
H8 - 1	1	Compressor – High Capacity Output – N/O
H8 - 2		24 VAC Common
H8 - 3		No Connection
H8 - 4		Auxiliary Heat Stage #1 / Hydronic Heat Output N/O (24 VAC)
H8 - 5		24 VAC Common
TB1 - 1	1	Humidistat Signal Input
TB1 - 2	2	Thermostat - Heat Stage #4 (W4) Input – Signal



**Table 6: MicroTech III Controller Configuration Jumper Settings**

Baseboard Description	Jumper(s)	Setting	Model
Normal / Test Mode	JP1	JP1 = Open	Normal Operation
		JP1 = Shorted	Service / Test Mode
Fan Operation	JP2	JP2 = Open	Continuous Fan Operation (On)
		JP2 = Shorted	Cycling Fan Operation (Auto)
Loop Fluid	JP3	JP3 = Open	Water Loop Fluid
		JP3 = Shorted	Glycol Loop Fluid
Freeze Fault Protection	JP4	JP4 = Open JP4 = Shorted	Not Used
Room Sensor Setpoint Potentiometer Range	JP5	JP5 = Open	Short Range: -5 to +5 °F (-2.78 to +2.78 °C)
		JP5 = Shorted	Long Range: 55 to 95 °F (12.78 to 35 °C)
Thermostat / Room Sensor	JP6	JP6 = Open	Thermostat Control
		JP6 = Shorted	Room Sensor Control
Compressor Heating Source	JP7	JP7 = Open	Allow Compressor Heating Mode Operation
		JP7 = Shorted	Disable Compressor Heating Mode Operation
I/O Expansion Module	JP8	JP8 = Open	I/O Expansion Board Not Present
		JP8 = Shorted	I/O Expansion Board Is Required

**⚠ WARNING**

Proper antifreeze/water solution is required to minimize the potential of fluid freeze-up. Jumper JP3 is factory set for water freeze protection with the jumper open. Operation with anti-freeze protection requires JP3 to be field configured for the jumper closed. If unit is employing a fresh water system (no anti-freeze protection), it is extremely important that JP3 jumper setting remains in the open position (factory default setting) in order to shut down the unit at the appropriate water temperature to protect your heat pump from freezing. Failure to do so can result in unit damage and fluid leaks."

**Table 7: MicroTech III Controller Status LED's**

Description	Type	Yellow	Green	Red
I/O Expansion Communication Fail	Fault	ON	Flash	Flash
Invalid Configuration	Fault	Flash	Flash	OFF
Low Voltage Brownout	Fault	OFF	Flash	OFF
Emergency Shutdown	Mode	OFF	Flash	OFF
Compressor High Pressure	Fault	OFF	OFF	Flash
Compressor Low Pressure	Fault	OFF	OFF	ON
Compressor Suction Temp Sensor Fail	Fault	Flash	Flash	ON
Compressor Low Suction Temp	Fault	Flash	OFF	OFF
Freeze Fault Detect	Fault	Flash	OFF	Flash
Room Temp Sensor Fail (Room Sensor Control Only)	Fault	Flash	Flash	ON
Leaving Water Temp Sensor Fail	Fault	Flash	Flash	ON
Condensate Overflow	Fault	ON	OFF	OFF
Serial EEPROM Corrupted	Fault	ON	ON	ON
Service Test Mode Enabled	Mode	Flash	Flash	Flash
Unoccupied Mode	Mode	ON	ON	OFF
Occupied, Bypass, Standby, or Tenant Override Modes	Mode	OFF	ON	OFF

\* Mode / Faults are listed in order of priority.

**Table 8: I/O Expansion Module Jumper Settings**

I/O Expansion Description	Jumper(s)	Setting	Model
Fan Row Select for Operating Modes: • Fan Only	<b>JP1 &amp; JP2</b>	JP1 = Open JP2 = Open	Fan Row "A" Selected
		JP1 = Shorted JP2 = Open	Fan Row "B" Selected
		JP1 = Open JP2 = Shorted	Fan Row "C" Selected
		JP1 = Shorted JP2 = Shorted	Fan Row "D" Selected
Secondary Heating Options	<b>JP3 &amp; JP4</b>	JP3 = Open JP4 = Open	None
		JP3 = Shorted JP4 = Open	Supplemental Electric Heat
		JP3 = Open JP4 = Shorted	Boilerless Electric Heat
		JP3 = Shorted JP4 = Shorted	Not Used
Not Used	<b>JP5 &amp; JP6</b>	JP5 = Open JP6 = Open	None
		JP5 = Shorted JP6 = Open	Not Used
		JP5 = Open JP6 = Shorted	Not Used
Not Used	<b>JP7</b>	JP7 = Open	–
Compressor Capacity Option	<b>JP8</b>	JP8 = Open JP8 = Shorted	Not Used

\* I/O Expansion module supplied with Boilerless or Supplemental Electric Heat option.

**Table 9: I/O Expansion Module LED & Fault Outputs**

Description	Type	Yellow	Green	Red
Baseboard Communication Fail	Fault	Flash	OFF	Flash
Entering Water Temp Sensor Fail (Boilerless Electric Heat)	Fault	ON	OFF	Flash
Low Entering Water Temperature (No Display On Boilerless Electric Heat)	Fault	OFF	ON	Flash
Fan is OFF	Mode	OFF	ON	OFF
Fan Running at Low Speed (0 to 33%) Duty Cycle	Mode	OFF	Flash	OFF
Fan Running at Medium Speed (34 to 66%) Duty Cycle	Mode	ON	Flash	OFF
Fan Running at High Speed (67 to 100%) Duty Cycle	Mode	Flash	Flash	OFF

**Notes:** 1. Mode / faults are listed in order of priority.

## MicroTech III Controller With LONWORKS® Communication Module

This manual covers the installation of a Daikin Horizontal Ceiling Hung Unit - Model CCH, CCW Water Source Heat Pump. For installation and operation information on LONWORKS Communication Module and other ancillary control components, see:

- IM 927 - MicroTech III Water Source Heat Pump LONWORKS Communication Module
- IM 933 - LonMaker Integration Plug-in Tool: For use with the MicroTech III Unit Controller
- IM 955 - MicroTech III Wall Sensor for use with Microtech III Unit Controller

**Figure 15: LONWORKS Communication Module**

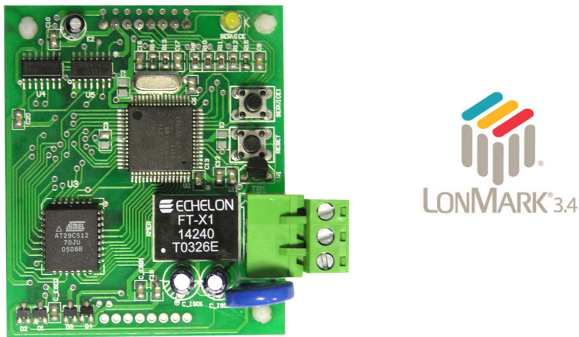

The LONWORKS communication module will plug into the Microtech III unit controller at the CN\_LON1 Header (see [Figure 17 on page 24](#)).

Each Daikin water source heat pump can be equipped with a LONWORKS communication module. The controller is microprocessor-based and is designed to communicate over a LONWORKS communications network. The unit controller is factory programmed and tested with all the logic required to monitor and control the unit. The wall thermostat sets the unit mode of operation. The unit controller monitors water and air temperatures, and can communicate fault conditions to a LONWORKS communications network.

The MicroTech III unit controller with communication module includes a unit-mounted return air, discharge air and leaving water temperature sensor. Wall mounted temperature sensors include setpoint adjustment and tenant override. The user has the capability of substituting the wall sensor with a duct-mounted return air sensor.

Each unit controller orchestrates the following unit operations:

- Enable heating and cooling to maintain setpoint based on a room sensor.
- Enable fan and compressor operation.
- Monitor all equipment protection controls.
- Monitor discharge air temperature.
- Monitor leaving water temperature.
- Relay status of all vital unit functions.
- Support optional control outputs.

MicroTech III heat pumps with a MicroTech III unit controller are LONMARK certified and designed to be linked with a centralized building automation system through a LONWORKS communications network for centralized scheduling and management of multiple heat pumps. Wall-mounted room sensors are available to control the heating and cooling operation of each MicroTech III Water Source Heat Pump Unit Controller. Available room sensors include: room sensor with LED status and tenant override button, room sensor with LED status, timed-override button, room sensor with LED status, timed-override button, and setpoint adjustment, and room sensor with LED status, timed-override button, setpoint adjustment.

The MicroTech III water source heat pump unit controller provides control of Daikin water source heat pumps. The controller enables the mode of operation, monitors the water and air temperatures, and indicates fault conditions. Each unit controller is factory programmed, wired, and tested for effective operation of your Daikin water source heat pump.

The MicroTech III water source heat pump controller uses LONWORKS technology.

LONMARK® 3.4 certified application code is the current standard application code for MicroTech III units.



## MicroTech III Controller with BACnet® Communication Module

For installation and operation information on MicroTech III unit controller and other ancillary components, see:

- IM 928 - MicroTech III BACnet Communication Module
- OM 931 - MicroTech III Unit Controller for Water Source Heat Pumps Operation and Maintenance Manual
- IM 955 - MicroTech III Wall Sensor For use with Microtech III Unit Controller

Daikin water source heat pumps are available with Daikin BACnet MS/TP communication module that is designed to communicate over a BACnet MS/TP communications network to a building automation system (BAS). It can be factory or field-installed.

The unit controller is programmed and tested with all the logic required to monitor and control the unit. An optional wall sensor may be used with the communication module to provide limited local control of the water source heat pump. The unit controller monitors water and air temperatures and passes information to the communication module. The module communicates with the BAS, to provide network control of the water source heat pump.

The module makes operational data and commands available on a communications network using BACnet objects and properties:

- The network cable is a shielded twisted-pair cable
- Network communications run up to 76.8 Kbps
- DIP switches on the controller enable the MS/TP MAC address to be set in the range 0-127

### NOTICE

When installing a MicroTech III Horizontal unit size 007, 009 or 012 which are provided with a factory-mounted BACnet communication module, it is suggested that the MAC address dip switches on the communication module be set prior to installing the unit in the ceiling. Access to the dip switches may be limited when the unit is installed. Reference IM 928 for addressing methods available.

- Four green status LEDs on the communication module indicate communication activity on the MS/TP communication network and with the unit controller

Figure 16: MicroTech III BACnet Water Source Heat Pump Snap-in Communication Module

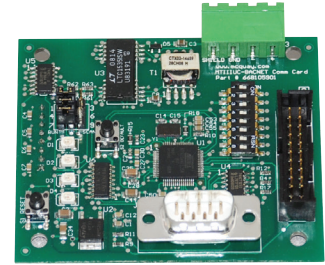

MicroTech III Unit Controller with BACnet MS/TP Communication Module orchestrates the following unit operations:

- Enable heating and cooling to maintain setpoint based on a room sensor
- Enable fan and compressor operation
- Monitors all equipment protection controls
- Monitors room and discharge air temperatures
- Monitors leaving water temperature
- Relays status of all vital unit functions

### The MicroTech III Unit Controller with Communication Module Includes:

- Return Air Temperature sensor (RAT) (field-installed)
- Discharge Air Temperature sensor (DAT) (field-installed)
- Leaving Water Temperature sensor (LWT) (factory installed)

**Note:** Refer to IM 956 for details to install (RAT) and (DAT) sensors.

### CAUTION

When an optional wall-mounted room temperature sensor is connected to the unit controller, the Return Air Temperature (RAT) sensor must not be installed. A wall-mounted room temperature sensor and the return air temperature sensor must not be connected simultaneously or the unit will not operate properly.

The communication module provides access to setpoints for operational control

### Available Wall Sensors Include:

- Room sensor with LED status and tenant override button
- Room sensor with LED status, tenant override button, and  $\pm 3^{\circ}\text{F}$  setpoint adjustment
- Room sensor with LED status, tenant override button,  $55^{\circ}$  to  $95^{\circ}\text{F}$  setpoint adjustment

Figure 17: LonWorks® Communication Module Placement on MicroTech™ III Unit Controller

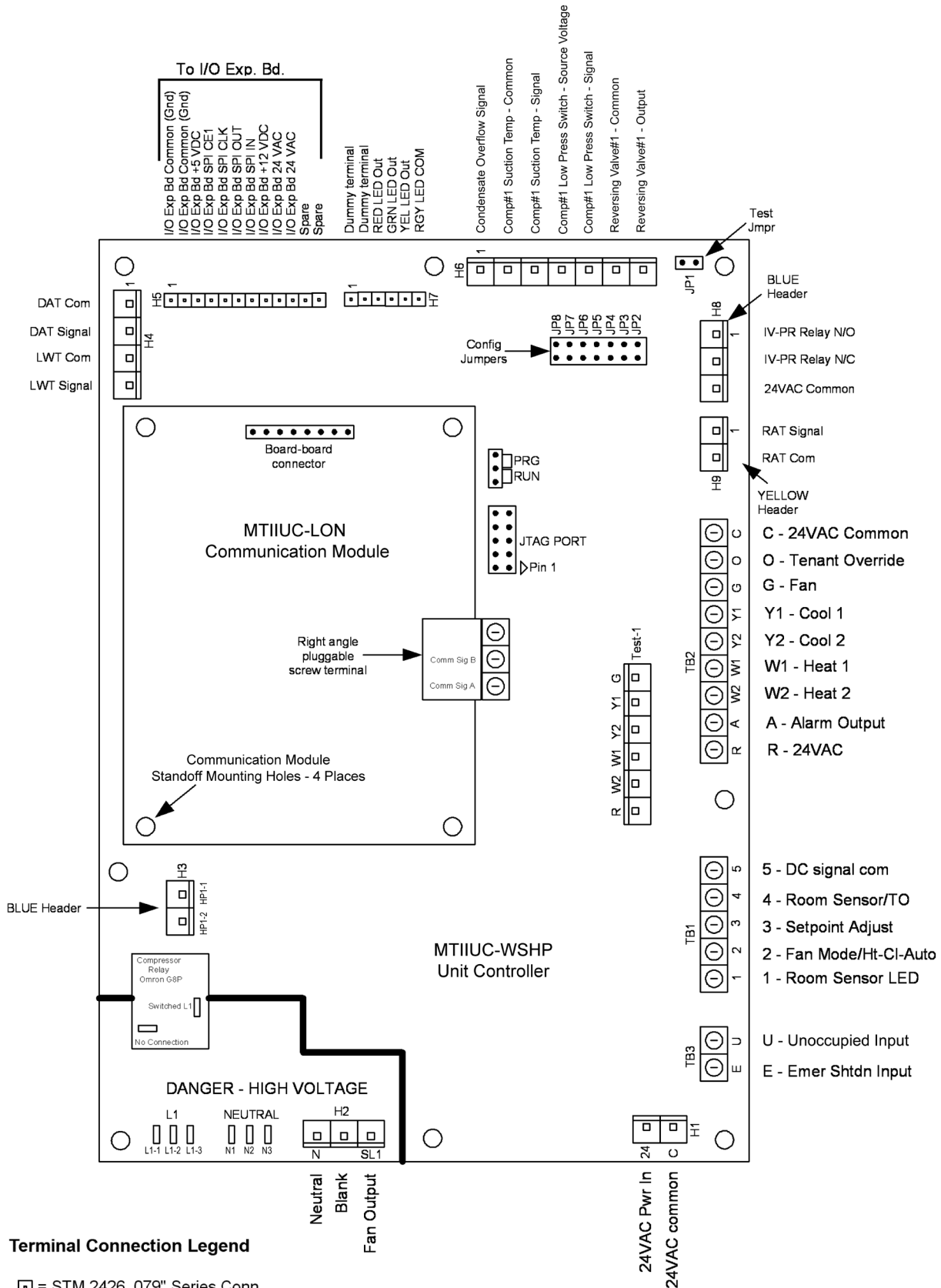

## Changing PSC Fan Motor Speed

The fan motor can be changed from high to low speed or vice versa by interchanging the wires on the black and red labeled terminals on the motor terminal block.

### **⚠ DANGER**



**Hazardous Voltage!**

The installer must determine and follow all applicable codes and regulations. This equipment presents hazards of electricity, rotating parts, sharp edges, heat and weight. Failure to read and follow these instructions can result in property damage, severe personal injury or death.

### **⚠ CAUTION**

Sharp edges can cause personal injury. Avoid contact with them..

**Table 10: Fan Motor Voltage and Terminal Slots**

CCH, CCW R410-A				
Unit Size	Volts and Number of Terminal Slots			Factory Fan Speed
	208V	460V	575V	
007	4	4	4	High
009	4	4	4	High
012	4	4	4	High
015 (standard static)	4	4	4	Low
019	4	4	4	High
024 (low static)	4	4	4	High
024 (standard static)	4	4	4	Low
030	4	4	4	High
036	4	4	4	High
042	4	4	5	High
048	4	5	5	Low
060	4	5	5	High
070	4	5	5	High

## Unit Sizes 007, 009, 012 (All Available Voltages)

Fan motors on unit sizes 007, 009, 012 (all available voltages) are factory wired for high. To change between high and low speed, interchange the red and black wires.

**Figure 18: Sizes 007 through 012 (all available voltages)**

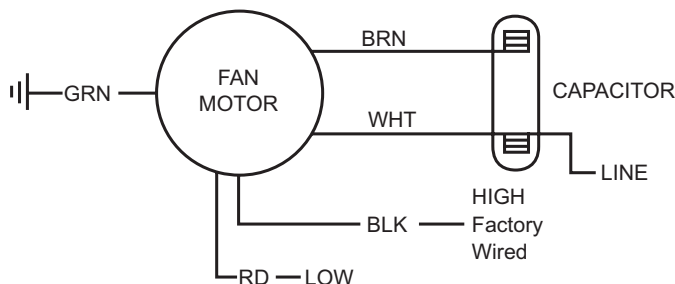

## Unit Size 015 (All Available Voltages) and Size 024 (208-230/60/1, 208-230/60/3, 265/60/1, 230/50/3)

Fan motor on unit size 015 in all available voltages and size 024 in voltages 208-230/60/1, 208-230/60/3, 265/60/1 and 230/50/3 have a four-position terminal block and are factory wired for low speed (Figure 19). To change between high and low speed, interchange the red and black wires.

**Figure 19: Size 015 (all available voltages) and size 024 in voltages 208-230/60/1, 208-230/60/3, 265/60/1 and 230/50/3 are factory wired for low speed**

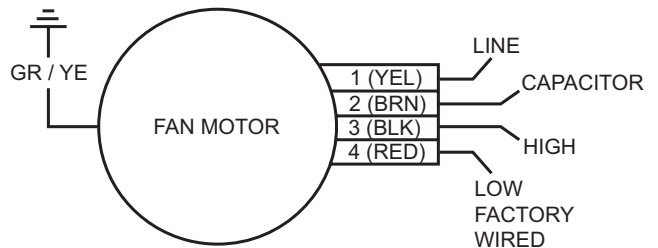

## Unit Size 024, 460V Standard Static

Fan motor on unit size 024 in 460/60/3 have a four-position terminal block and are factory wired for low speed (Figure 21). To change to high speed, remove and cap the purple wire (factory wired to terminal block position 3) and move the wire from terminal block position 4, to terminal block position 3 (Figure 20).

**Figure 20: Size 024, 460V standard static, wired for high speed**

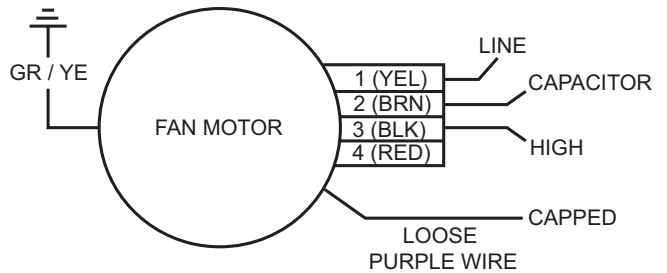

**Figure 21: Size 024, 460V standard static, factory wired for low speed**

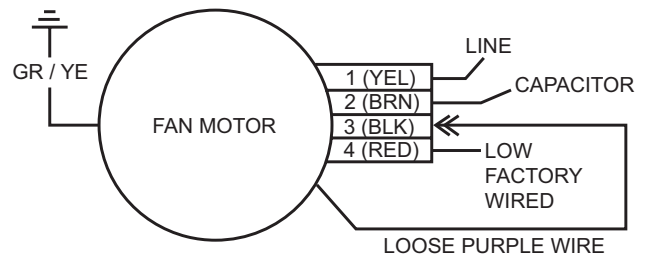

**Unit Sizes 019 and 036 (All Available Voltages) and Size 024 (Low Static, All Available Voltages) and Size 030 (208-230/60/1, 208-230/60/3, 265/60/1, 230/50/3)**

Fan motors on unit sizes 019 and 036 in all available voltages, and size 024 (low static) in all available voltages and size 030 in voltages 208-230/60/1, 208-230/60/3, 265/60/1 and 230/50/3 have a four-position terminal block and are factory wired for high speed (Figure 22). To change between high and low speed, interchange the red and black wires.

**Figure 22: Sizes 019, and 036 (standard static, all available voltages) and size 024 (low static, all available voltages) and size 030 in voltages 208-230/60/1, 208-230/60/3, 265/60/1 and 230/50/3 are factory wired for high speed**

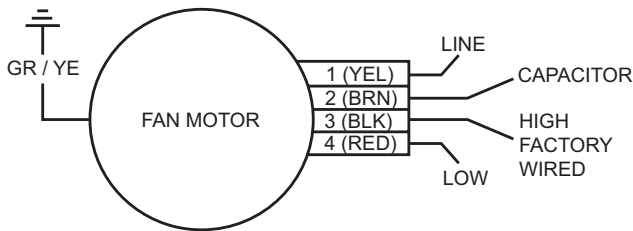

**Unit Size 030, 460V Standard Static**

Fan motor on unit size 030 in 460/60/3 have a four-position terminal block and are factory wired for high speed (Figure 23). To change to low speed, move the wire from terminal block position 3, to terminal block position 4. Additionally, wire the purple wire to position 3 (wire comes loose and capped from the factory) (Figure 24).

**Figure 23: Size 030, 460V standard static, factory wired for high speed**

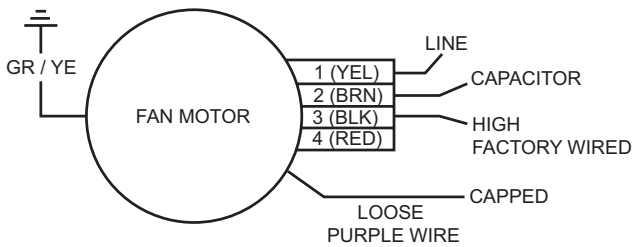

**Figure 24: Size 030, 460V standard static, wired for low speed**

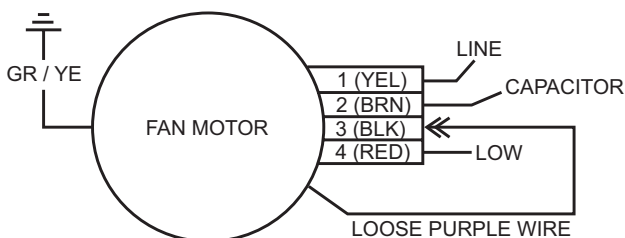

**Unit Size 042 (208-230/60/1, 208-230/60/3, 380/50/3, 460/60/3)**

The fan motor on unit size 042 in voltages of, 208-230/60/1, 208-230/60/3, 380/50/3 and 460-60-3 have a four-position terminal block and are factory wired for high speed (Figure 25). To change between high and low speed, interchange the red and black wires.

**Figure 25: Sizes 042 (208-230/60/1, 208-230/60/3, 380/50/3, 460/60/3) factory wired for high speed**

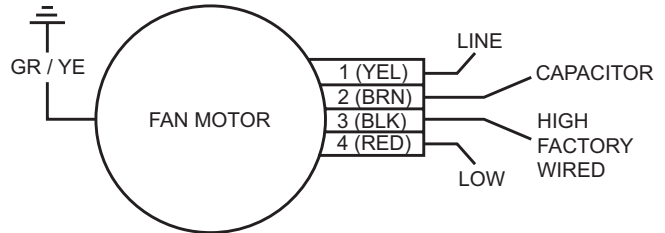

**Unit Size 042 (575/60/3)**

The fan motor on unit size 042 for voltage 575/60/3 has a five-position terminal block and is factory wired for high speed (Figure 26). Low speed can be achieved by interchanging black terminal (3) with red terminal (5) and the black and blue terminals (3 & 4) receive a jumper as shown in Figure 27.

**Figure 26: Size 042 (575/60/3) factory wired for high speed**

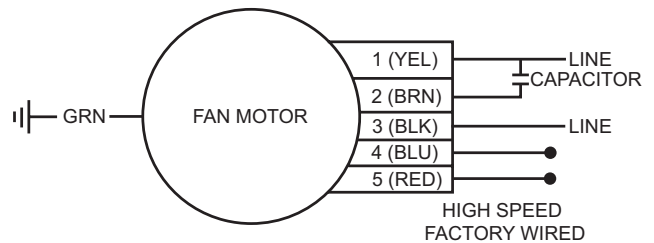

**Figure 27: Size 042 (575/60/3) low speed**

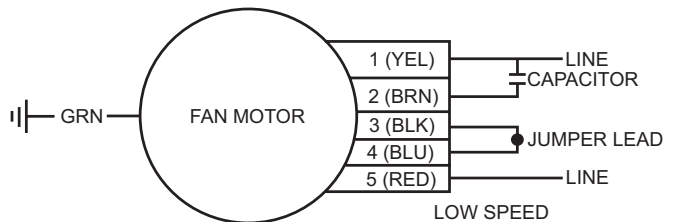

### Unit Size 048 (208-230/60/1 and 208-230/60/3)

The fan motor on unit size 048 for voltages 208/230/60/1 and 208-230/60/3 have a four-position terminal block and are factory wired for low speed (Figure 28). High speed can be achieved by interchanging black terminal (3) with red terminal (4).

Figure 28: Size 048 (208-230/60/1 and 208-230/60/3) factory wired for low speed

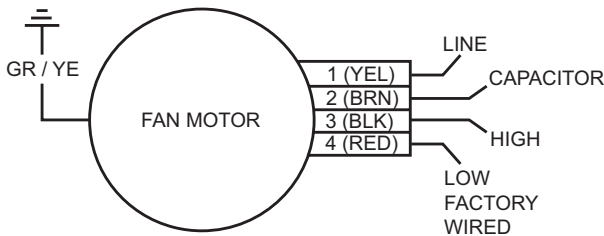

### Unit Size 048 (380/50/3, 460/60/3, 575/60/3)

The fan motor on unit size 048 for voltages 380/50/3, 460/60/3 and 575/60/3 have a five-position terminal block and are factory wired for low speed (Figure 29). High speed can be achieved by interchanging black terminal (3) with red terminal (5) as shown in Figure 30.

Figure 29: Size 048 (380/50/3, 460/60/3, 575/60/3) factory wired for low speed

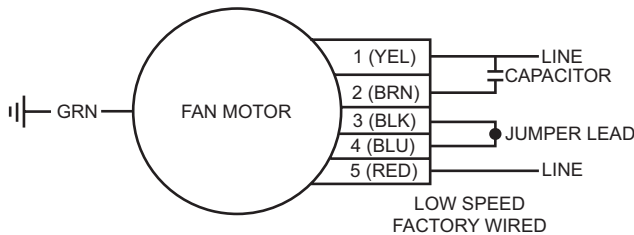
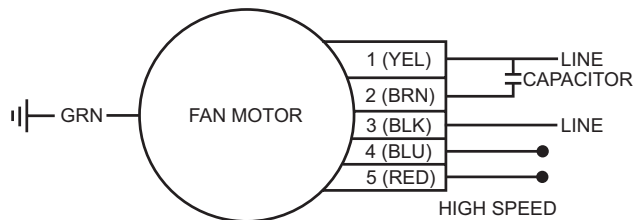

Figure 30: Size 048 (380/50/3, 460/60/3, 575/60/3) high speed



### Unit Size 060 (208-230/60/1) and (208-230/60/3)

The fan motor on unit size 060 in voltages 208-230/60/1 and 208-230/60/3 have a four-position terminal block and are factory wired for high speed (Figure 31). Low speed can be achieved by interchanging black terminal (3) with red terminal (4).

Figure 31: Sizes 060 (208-230/60/1) and (208-230/60/3)

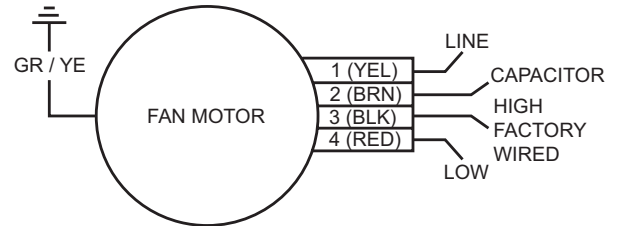

### Unit Size 060 (380/50/3, 460/60/3, 575/60/3)

The fan motor on unit size 060 for voltages 380/50/3, 460/60/3 and 575/60/3 (Figure 32) have a five-position terminal block and are factory wired for high speed. Low speed can be achieved by interchanging black terminal (3) with red terminal (5) and the black and blue terminals (3 & 4) receive a jumper as shown in Figure 33.

Figure 32: Size 060 (380/50/3, 460/60/3, 575/60/3) factory wired for high speed

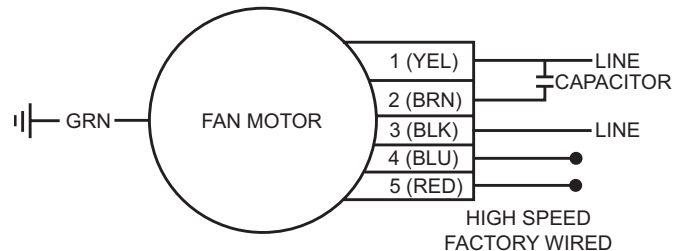
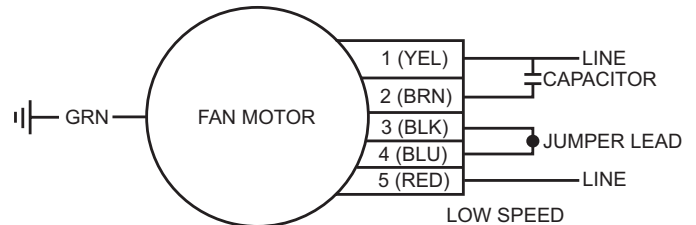

Figure 33: Size 060 (380/50/3, 460/60/3, 575/60/3) low speed



### Unit Size 070 (208-230/60/3)

The fan motor on unit size 070 in voltage 208-230/60/3 has a four-position terminal block and is factory wired for high speed (Figure 34). Low speed can be achieved by interchanging black terminal (3) with red terminal (4).

Figure 34: Sizes 070 (208-230/60/3)

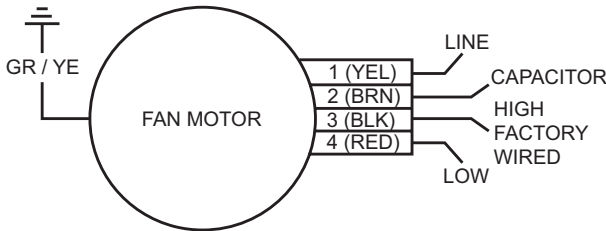

### Unit Size 070 (460/60/3, 575/60/3)

The fan motor on unit size 070 for voltages 460/60/3 and 575/60/3 (Figure 35) have a five-position terminal block and are factory wired for high speed. Low speed can be achieved by interchanging black terminal (3) with red terminal (5) and the black and blue terminals (3 & 4) receive a jumper as shown in Figure 36.

Figure 35: Size 070 (460/60/3, 575/60/3) Factory Wired for High Speed

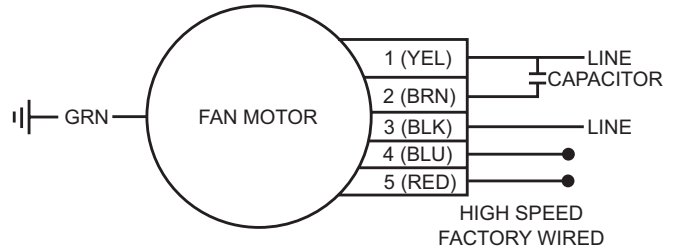
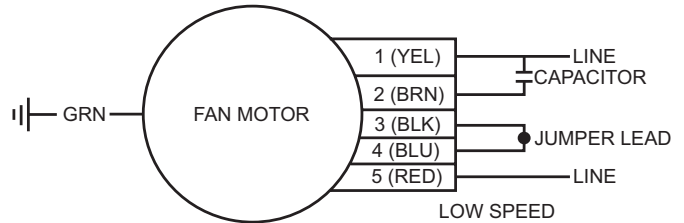

Figure 36: Size 070 (460/60/3, 575/60/3) Low Speed



**Notes:** All motors have a wiring label that is keyed for proper wiring operation. Check unit wiring diagram (on electrical access panel) for proper unit operation. Not all labels are the same. Units leaving the factory are wired for high or low fan speed (see Table 11 on page 29 or Table 12 on page 29 for fan speed settings). Label is located on the back of the terminal block.



# Factory Fan Speed Settings

**Table 11: Standard PSC Static Motor**

Unit Size	Speed	Factory Wired	Nominal cfm	External Static Pressure (in. w.c.)													
				0.10	0.15	0.20	0.25	0.30	0.35	0.40	0.45	0.50	0.55	0.60	0.65	0.70	0.75
007	High	Yes	300	410	400	390	380	360	350	330	320	310	290	270	250		
009	High	Yes	300	410	400	390	380	360	350	330	320	310	290	270	250		
012	Low	No	400	350	340	330	320	300									
	High	Yes		430	420	400	390	370	360	340	320	300					
015	Low	Yes	500	690	670	650	620	590	560	520	480	440	390				
	High	No		950	930	910	880	850	810	770	720	660	610	540	480	400	
019	Low	No	630	670	650	640	610	590	570	540	510						
	High	Yes		890	870	840	820	790	760	730	700	660	620				
024	Low	Yes	800	1000	990	980	970	950	940	910	890	880	830	800	760	720	660
	High	No		1190	1170	1150	1130	1110	1090	1060	1030	990	950	920	880	820	770
030	Low	No	1000	1050	1040	1030	1020	1010	990	970	950	920	890	850	820	770	
	High	Yes		1270	1260	1240	1210	1190	1170	1140	1110	1070	1030	980	940	890	840
036	Low	No	1200				1170	1170	1160	1140	1120	1090	1060	1020	980	940	900
	High	Yes		1510	1500	1480	1460	1430	1390	1350	1310	1260	1200	1150	1090	1040	980
042	Low	No	1400					1450	1440	1420	1370	1280	1200	1120			
	High	Yes		2130	2110	2090	2050	2020	1970	1930	1870	1790	1690	1580	1460	1250	
048	Low	Yes	1600	2100	2070	2030	1990	1950	1900	1850	1790	1720	1600	1400			
	High	No		2440	2380	2330	2260	2200	2130	2070	2000	1910	1780	1590	1410		
060	Low	No	2000			2080	2070	2050	2020	1980	1940	1900	1850	1770	1680		
	High	Yes		2600	2570	2530	2490	2440	2390	2320	2260	2180	2100	2010	1920	1620	
070	Low	No	2300			2080	2070	2050	2020	1980	1940	1900	1850	1770	1680		
	High	Yes		2600	2570	2530	2490	2440	2390	2320	2260	2180	2100	2010	1920	1620	

Note: PSC blower motors are designed to deliver nominal 400 cfm/ton.

**Table 12: Low Static PSC Motor**

Unit Size	Speed	Factory Wired	Nominal cfm	External Static Pressure (in. w.c.)													
				0.10	0.15	0.20	0.25	0.30	0.35	0.40	0.45	0.50	0.55	0.60	0.65	0.70	0.75
024	Low	No	800	670	650	640	610										
	High	Yes		890	870	840	820	790	760	730	700	660	620				

Note: For wet coil, calculate face velocity (cfm/ coil face area, sq. ft.). Add the following static to the external static pressure for the corresponding face velocity: 300 fpm = 0.05", 400 fpm = 0.10", 500 fpm = 0.14". Re-enter table at the increased external static pressure to determine final cfm.   = Out of Range



## Fan Speed Selector Switch

A 4-position fan speed selector switch located in the control box allows CFM settings to be field adjustable. Fan speed control optimizes unit fan speed based on thermostat/room sensor inputs. The fan speed switch allows for manually setting an optimal fan speed specific to the application requirements. Each position on the fan speed switch represents settings 1-4. See [Table 13](#) below and [Table 14 on page 31](#) for the complete list of fan speed selector switch settings.

Figure 37: 4-Position Fan Speed Selector Switch



## Fan Performance For Optional Constant Torque EC Motor (Sizes 007–012)

Table 13: Constant Torque Motor CFM Values - Sizes 007–012

Unit Size	Setting	Function	External Static Pressure (inches of water column)												
			.10	.15	.20	.25	.30	.35	.40	.45	.50	.55	.60	.65	.70
007	Setting 4 (High)	Stage 1	386	379	370	357	348	337	330	327	316	308	290	277	270
	Setting 3 (Standard)		357	349	335	322	312	308	301	290	280	265	253	245	239
	Setting 2 (Medium)		324	311	299	288	285	275	266	247	237	227	222	215	208
	Setting 1 (Low)		324	311	299	288	285	275	266	247	237	227	222	215	208
	Setting 4 (High)	Stage 2	410	407	398	388	375	368	357	355	349	339	330	323	313
	Setting 3 (Standard)		386	379	370	357	348	337	330	327	316	308	290	277	270
	Setting 2 (Medium)		357	349	335	322	312	308	301	290	280	265	253	245	239
	Setting 1 (Low)		324	311	299	288	285	275	266	247	237	227	222	215	208
	A	Fan Only	386	379	370	357	348	337	330	327	316	308	290	277	270
	B		357	349	335	322	312	308	301	290	280	265	253	245	239
	C		324	311	299	288	285	275	266	247	237	227	222	215	208
	D		270	256	250	243	223	207	197	193	180	171	159	147	130
009	Setting 4 (High)	Stage 1	386	379	370	357	348	337	330	327	316	308	290	277	270
	Setting 3 (Standard)		357	349	335	322	312	308	301	290	280	265	253	245	239
	Setting 2 (Medium)		324	311	299	288	285	275	266	247	237	227	222	215	208
	Setting 1 (Low)		324	311	299	288	285	275	266	247	237	227	222	215	208
	Setting 4 (High)	Stage 2	410	407	398	388	375	368	357	355	349	339	330	323	313
	Setting 3 (Standard)		386	379	370	357	348	337	330	327	316	308	290	277	270
	Setting 2 (Medium)		357	349	335	322	312	308	301	290	280	265	253	245	239
	Setting 1 (Low)		324	311	299	288	285	275	266	247	237	227	222	215	208
	A	Fan Only	386	379	370	357	348	337	330	327	316	308	290	277	270
	B		357	349	335	322	312	308	301	290	280	265	253	245	239
	C		324	311	299	288	285	275	266	247	237	227	222	215	208
	D		270	256	250	243	223	207	197	193	180	171	159	147	130
012	Setting 4 (High)	Stage 1	412	403	391	378	367	355	345	335	323	293	275	259	250
	Setting 3 (Standard)		385	372	357	342	332	319	309	300	286	251	242	223	212
	Setting 2 (Medium)		353	339	327	313	298	288	274	265	228	211	203	183	177
	Setting 1 (Low)		353	339	327	313	298	288	274	265	228	211	203	183	177
	Setting 4 (High)	Stage 2	451	438	423	409	400	387	375	365	352	342	334	313	294
	Setting 3 (Standard)		412	403	391	378	367	355	345	335	323	293	275	259	250
	Setting 2 (Medium)		385	372	357	342	332	319	309	300	286	251	242	223	212
	Setting 1 (Low)		353	339	327	313	298	288	274	265	228	211	203	183	177
	A	Fan Only	412	403	391	378	367	355	345	335	323	293	275	259	250
	B		385	372	357	342	332	319	309	300	286	251	242	223	212
	C		353	339	327	313	298	288	274	265	228	211	203	183	177
	D		314	298	282	264	248	234	203	191	176	164	154	133	125

Notes: 1. For wet coil, calculate face velocity (cfm/coil face area, sq. ft.). Add the following static to the external static pressure for the corresponding face velocity: 300 fpm = 0.05", 400 fpm = 0.10", 500 fpm = 0.14". Re-enter table at the increased external static pressure to determine final cfm.

2. Actual unit performance may differ from those listed in the catalog and selection software due to variations in field conditions, unit installations, and test and balancing devices

## Fan Performance For Optional Constant CFM EC Motor (Sizes 015–070)

**Table 14: Single Stage Units with Constant CFM Type EC Motor - Sizes 015–070**

Unit Size	MicroTech III Unit Controller							I/O Expansion Module	
	Setting	Maximum ESP (in. wg.) <sup>2</sup>	<sup>1</sup> Low CFM Heat	<sup>1</sup> High CFM Heat	<sup>1</sup> Low CFM Cool	<sup>1</sup> High CFM Cool	Electric Heat	Setting	Fan Only
015	4 (High)	0.7	520	580	520	580	580	A	450
	3 (Standard)		450	520	450	520	580	B	410
	2 (Medium)		390	450	390	450	580	C	370
	1 (Low)		390	390	390	390	580	D	300
019	4 (High)	0.7	630	700	630	700	700	A	570
	3 (Standard)		560	630	560	630	700	B	520
	2 (Medium)		480	560	480	560	700	C	460
	1 (Low)		480	480	480	480	700	D	390
024	4 (High)	0.7	800	900	800	900	900	A	750
	3 (Standard)		700	800	700	800	900	B	710
	2 (Medium)		610	700	610	700	900	C	670
	1 (Low)		610	610	610	610	900	D	600
030	4 (High)	0.7	1020	1140	1020	1140	1140	A	900
	3 (Standard)		900	1020	900	1020	1140	B	790
	2 (Medium)		780	900	780	900	1140	C	690
	1 (Low)		780	780	780	780	1140	D	530
036	4 (High)	0.7	1160	1300	1160	1300	1300	A	1180
	3 (Standard)		1020	1160	1020	1160	1300	B	1060
	2 (Medium)		880	1020	880	1020	1300	C	940
	1 (Low)		880	880	880	880	1300	D	760
042	4 (High)	0.7	1400	1580	1400	1580	1580	A	1220
	3 (Standard)		1230	1400	1230	1400	1580	B	1040
	2 (Medium)		1050	1230	1050	1230	1580	C	860
	1 (Low)		1050	1050	1050	1050	1580	D	590
048	4 (High)	0.7	1600	1800	1600	1800	1800	A	1490
	3 (Standard)		1400	1600	1400	1600	1800	B	1320
	2 (Medium)		1200	1400	1200	1400	1800	C	1160
	1 (Low)		1200	1200	1200	1200	1800	D	900
060	4 (High)	0.7	2000	2260	2000	2260	2260	A	1860
	3 (Standard)		1760	2000	1760	2000	2260	B	1730
	2 (Medium)		1500	1760	1500	1760	2260	C	1590
	1 (Low)		1500	1500	1500	1500	2260	D	1390
070	4 (High)	0.7	2160	2400	2160	2400	2400	A	2010
	3 (Standard)		1920	2160	1920	2160	2400	B	1860
	2 (Medium)		1680	1920	1680	1920	2400	C	1720
	1 (Low)		1680	1680	1680	1680	2400	D	1500

**Notes:** 1 The unit is capable of high-low fan performance through the use of a 2-stage thermostat wired to specific terminals for High-Low CFM fan performance. Standard operation with a 1-stage thermostat is indicated as High CFM fan performance.

## Jumper Settings on I/O Expansion Module

In addition to the 4-position switch, all units have the capability to set CFM values independent to those associated with compressor operation. Independent CFM values can be set for fan only, from the jumper pins JP1 and JP2 on the I/O expansion module.

The jumper pin configurations represent settings A, B, C and D. See [Table 14 on page 31](#) under the I/O Expansion Module

These settings establish unique CFM settings for the four previously mentioned mode of operation. For example, unit size 036 with the 4-position switch set at Setting #3 and the I/O expansion module jumper set at B, will deliver 1160 CFM at stage 2 compressor operation mode, 1020 CFM at stage 1 compressor operation, 1300 CFM in electric heat mode, 1020 CFM in fan only mode.

**Figure 38: JP1 & JP2 Location on the I/O Expansion Module**

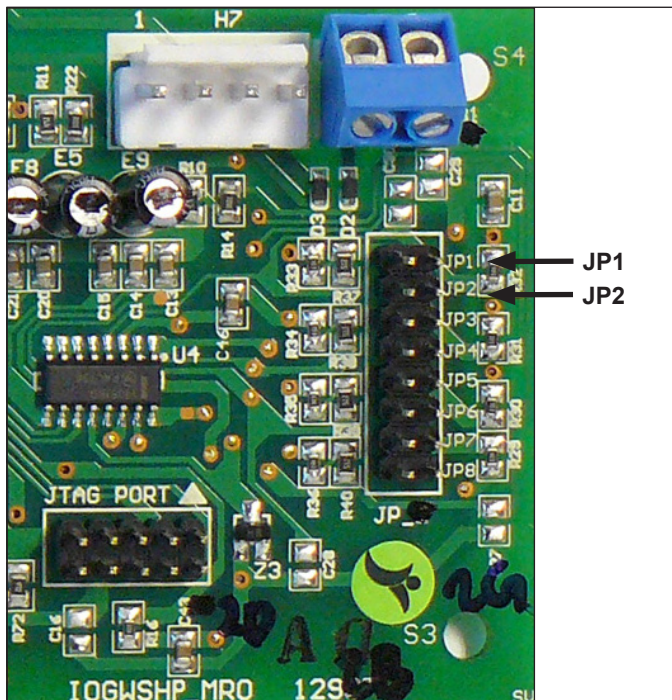

**Table 15: I/O Expansion Module Jumper Configuration**

I/O Expansion Module Configuration		
Setting	JP1	JP2
<b>A</b>	Open	Open
<b>B</b>	Shorted	Open
<b>C</b>	Open	Shorted
<b>D</b>	Shorted	Shorted

## Variable CFM

All units have the capability to deliver variable CFM based on the thermostat wiring. By using a multi-stage wall thermostat, the unit can deliver lower CFM as the space temperature is satisfied. For example, unit size 024 with the 4-position switch set at #3, and a 2-stage cooling wall thermostat will deliver 700 CFM at stage 1 cooling and 800 CFM at stage 2 cooling. All of this is accomplished by wiring the thermostat to the appropriate terminal on the MicroTech III controller terminal strip. The variable CFM feature allows for improved humidity levels by increasing latent cooling capacity through reduced CFM. Here, we are attempting to satisfy cooling at the lowest airflow, 700 CFM, but having the capability to deliver higher airflow, 800 CFM, if needed.

**Table 16: Standard CFM Settings**

Unit Size 024	Standard CFM Settings (Compressor is ON)	
Fan Setting	High CFM Cooling Stage 2	Low CFM Cooling Stage 1
#3	800	700

# MicroTech III Controller with PSC Motor – 115-60-1 Unit Sizes 007-009

Drawing No. 910161297

Wiring diagrams are typical. For the latest drawing version refer to the wiring diagram located on the inside of the controls access panel of the unit.

### Legend

Item	Description
C1	Capacitor-Compressor
C2	Capacitor-Fan
CM	Compressor - Motor
COS	Condensate Overflow Sensor
DAT	Discharge Air Temp Sensor
HP	High Pressure Switch
LOC	Loss of Charge Switch
LED1	LED Annunciator / Harness
SLTS	Suction Line Temp Sensor
LWT	Leaving Water Temp Sensor
MIII	MicroTech III Main Board
ISO-NC	Isolation Valve - Normally Closed
ISO-NO	Isolation Valve - Normally Open
RAT	Return Air Temp Sensor
RV	Reversing Valve Solenoid
X1	Primary 24VAC Transformer
—	Standard Unit Wiring
- - -	Optional Wiring (by others)

### Notes:

- Main board jumpers:  
No jumpers shorted, all open
-  Transformer:  
Unused wire to be capped.

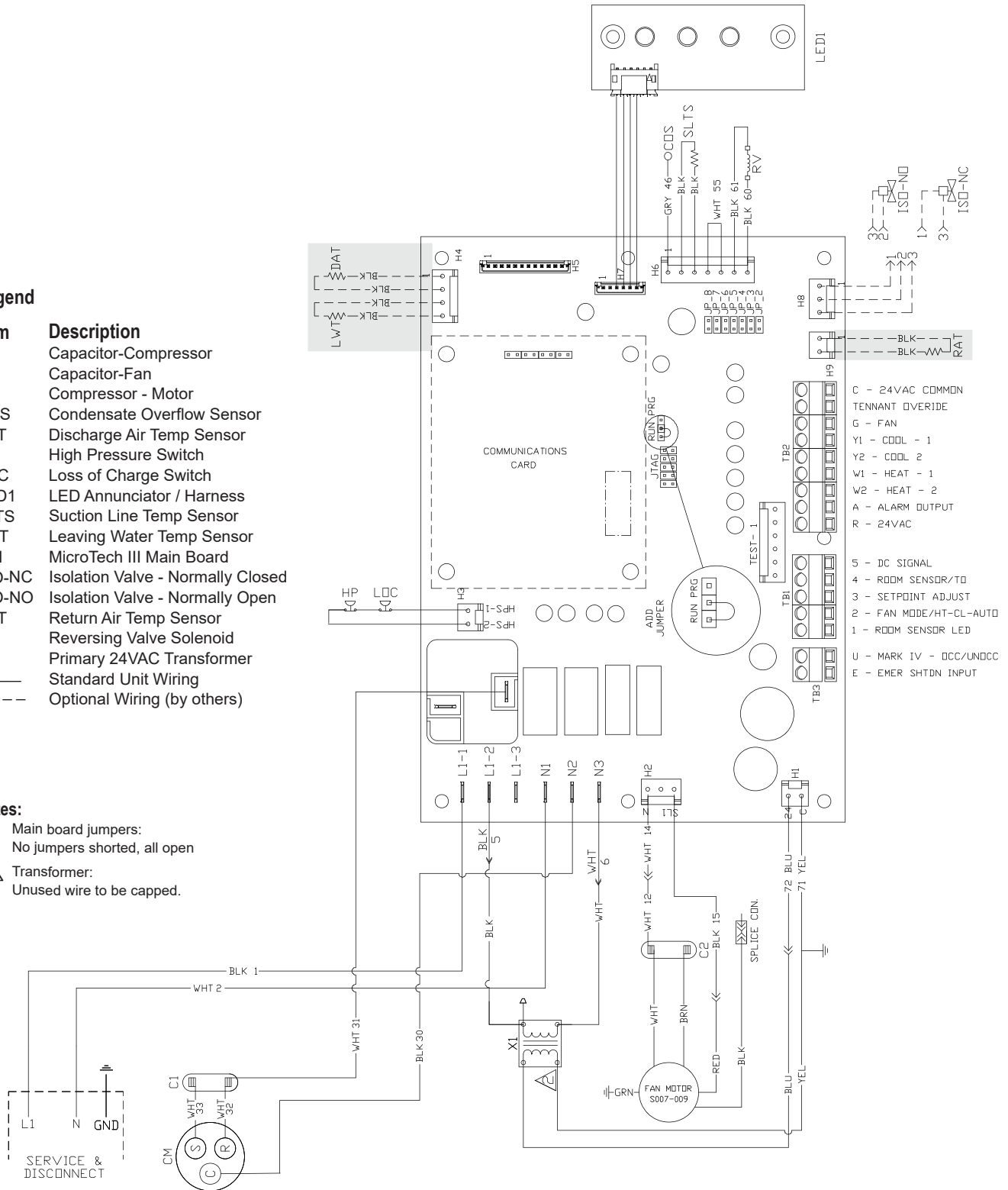

**Note:** Gray tint areas in wiring diagram: Units configured with a communication module include a Leaving Water (LWT), Discharge Air (DAT) and a Return Air (RAT) Temperature sensor. The DAT and RAT sensors are shipped loose inside the control box for field installation.

# MicroTech III Controller with PSC Motor, Communication Module – 208/230-60-1 Unit Sizes 015-060

Drawing No. 910167676

Wiring diagrams are typical. For the latest drawing version refer to the wiring diagram located on the inside of the controls access panel of the unit.

Table B	
208V	RED
230V	ORG

### Legend

Item	Description
C1	Capacitor-Compressor
C2	Capacitor-Fan
CC	Compressor Contactor
CM	Compressor - Motor
COS	Condensate Overflow Sensor
DAT	Discharge Air Temp Sensor
DISC	Non-Fused Disconnect Switch (Option)
HP	High Pressure Switch
ISO-NC	Isolation Valve - Normally Closed
ISO-NO	Isolation Valve - Normally Open
LED1	LED Annunciator / Harness
LP	Low Pressure Switch
LWT	Leaving Water Temp Sensor
MIII	MicroTech III Main Board
P1	24VAC Supply IO Expansion Board
R1	Relay - Fan Motor
RAT	Return Air Temp Sensor
RV	Reversing Valve SolenoidX1
M1	Fan Motor
X1	Primary 24VAC Transformer
—	Standard Unit Wiring
---	Factory Installed Options

### Notes:

- Main board jumpers:  
JP3 Geothermal
-  Transformer:  
Unused wire to be capped.

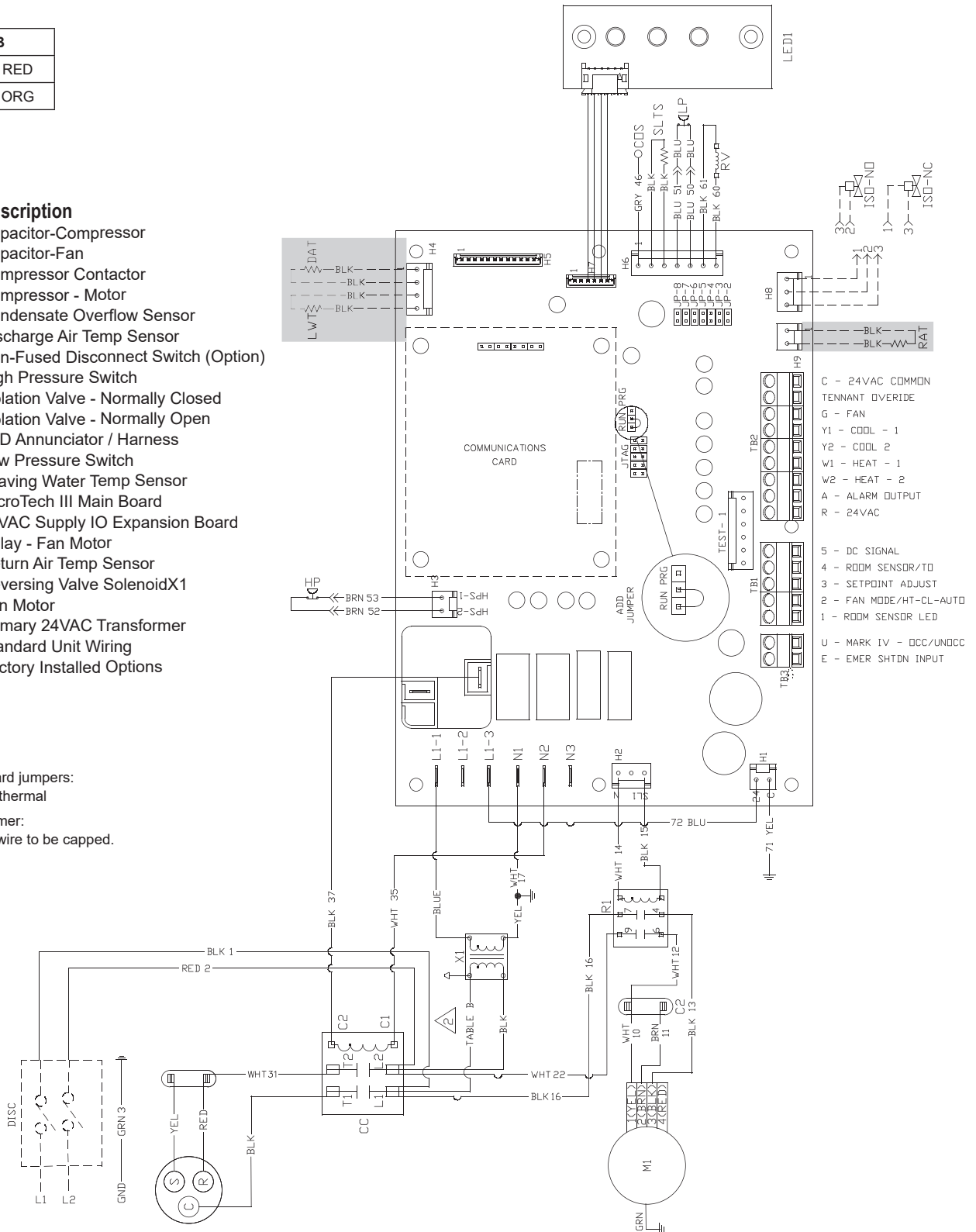

**Note:** Gray tint areas in wiring diagram: Units configured with a communication module include a Leaving Water (LWT), Discharge Air (DAT) and a Return Air (RAT) Temperature sensor. The DAT and RAT sensors are shipped loose inside the control box for field installation.

# MicroTech III Controller with PSC Motor – 208/230/460-60-3 Unit Sizes 024-070

Drawing No. 910201061

Wiring diagrams are typical. For the latest drawing version refer to the wiring diagram located on the inside of the controls access panel of the unit.

## Legend

Item	Description
C1	Capacitor-Compressor
C2	Capacitor-Fan
CC	Compressor Contactor
CM	Compressor - Motor
COS	Condensate Overflow Sensor
DAT	Discharge Air Temp Sensor
DISC	Non-Fused Disconnect Switch
EWT	Entering Water Temp Sensor
HP	High Pressure Switch
ISO-NC	Isolation Valve - Normally Closed
ISO-NO	Isolation Valve - Normally Open
LED1	LED Annunciator / Harness
LWT	Leaving Water Temp Sensor
LP	Low Pressure Switch
MIII	MicroTech III Main Board
R1	Relay - Fan Motor
RAT	Return Air Temp Sensor
RV	Reversing Valve Solenoid
SLTS	Suction Line Temp Sensor
TB1	Power Terminal Block
X1	Primary 24VAC Transformer
—	Standard Unit Wiring
- - -	Factory Installed Options

208V	RED
230V	ORG
380V	VIOLET
460V	BLK/RED

## Notes:

- Main board jumpers:  
JP3 Geothermal
- Transformer:  
Unused wire to be capped.
- Terminal block used on 380V, 50Hz  
3-phase units
- Numbers (colors) shown on motor  
diagram are terminal locations and do not  
refer to wire numbers/colors

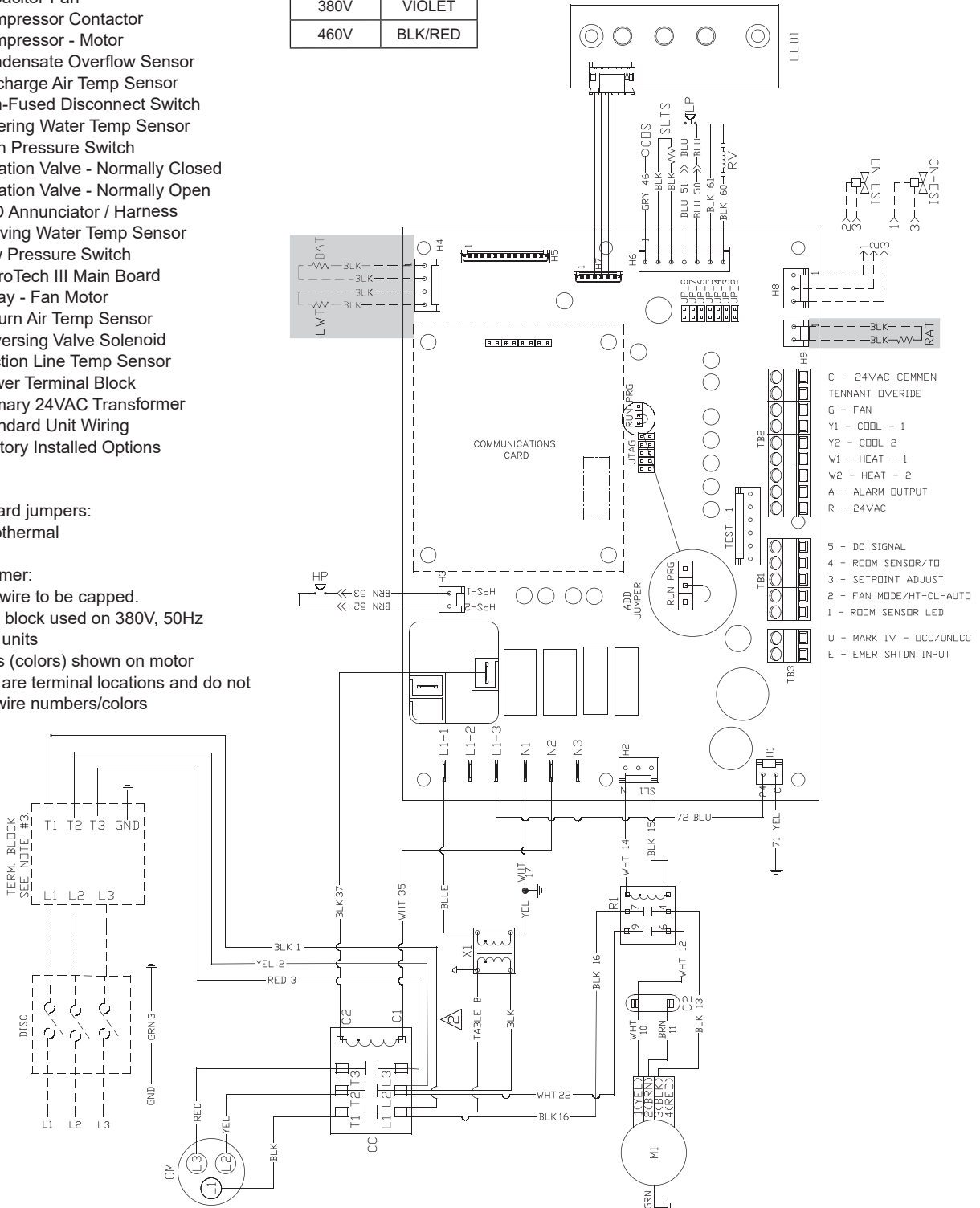

**Note:** Gray tint areas in wiring diagram: Units configured with a communication module include a Leaving Water (LWT), Discharge Air (DAT) and a Return Air (RAT) Temperature sensor. The DAT and RAT sensors are shipped loose inside the control box for field installation.



# MicroTech III Controller with EC Motor and Optional Comm – 208/230-60-3

## Unit Sizes 007–012

Drawing No. 910167992

Wiring diagrams are typical. For the latest drawing version refer to the wiring diagram located on the inside of the controls access panel of the unit.

Table B	
208V	RED
230V	BRN

### Legend

Item	Description
C1	Capacitor-Compressor
CC	Compressor - Contactor
CM	Compressor - Motor
COS	Condensate Overflow Sensor
DAT	Discharge Air Temp Sensor
DISC	Non-Fused Disconnect Switch (Opt)
EB2	Exp Brd 2 - Fan Speed Cntl
HP	High Pressure Switch
IOEXP	I/O Expansion Board / Harness
ISO-NC	Isolation Valve - Normally Closed
ISO-NO	Isolation Valve - Normally Open
LED1	LED Annunciator / Harness
LED2	LED Annunciator / Harness
LP	Low Pressure Switch
LWT	Leaving Water Temp Sensor
MIII	MicroTech III Main Board
RAT	Return Air Temp Sensor
RV	Reversing Valve Solenoid
SLTS	Suction Line Temp Sensor
X1	Primary 24VAC Transformer
—	Standard Unit Wiring
---	Factory Installed Options
OVL	Compressor Overload

### Notes:

- Main Board Jumpers
    - JP2** Shorted for cycling fan
    - JP3** Geothermal
    - JP8** Shorted for IO Board Comm
  - IO Expansion Board Jumpers
    - All open for single stage compressor
- 3 Transformer:**  
Unused wire to be capped.

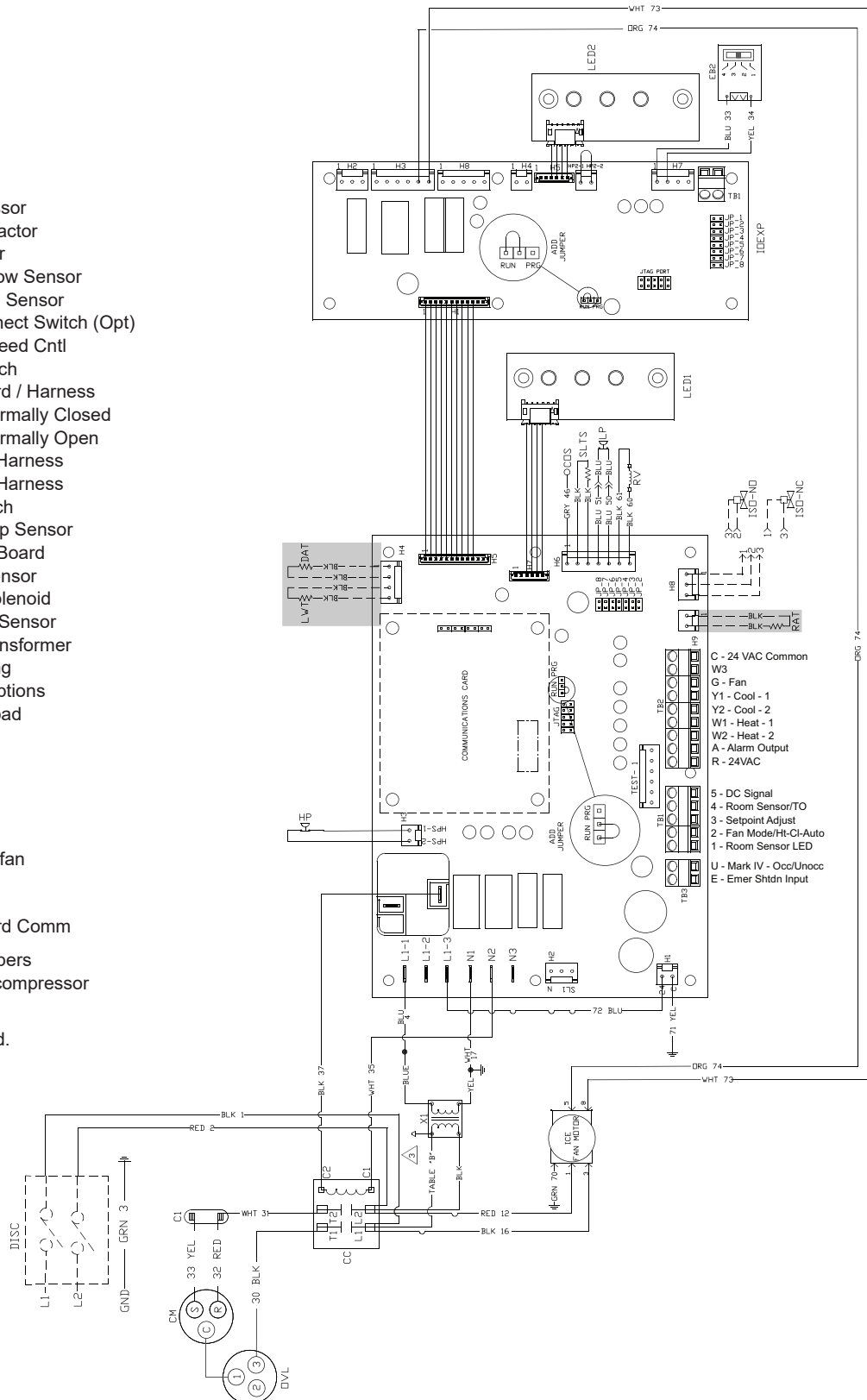

**Note:** Gray tint areas in wiring diagram: Units configured with a communication module include a Leaving Water (LWT), Discharge Air (DAT) and a Return Air (RAT) Temperature sensor. The DAT and RAT sensors are shipped loose inside the control box for field installation.



# MicroTech III Controller with EC Motor and Optional Comm – 208/230-60-1 Unit Sizes 019-070

Drawing No. With Nidec EC Motor (910269510) and Genteq EC Motor Detail (910154305)

Wiring diagrams are typical. For the latest drawing version refer to the wiring diagram located on the inside of the controls access panel of the unit.

Table B	
208V	RED
230V	ORG

### Legend

Item	Description
C1	Capacitor-Compressor
CC	Compressor - Contactor
CM	Compressor - Motor
COS	Condensate Overflow Sensor
DAT	Discharge Air Temp Sensor
DISC	Non-Fused Disconnect Switch (Opt)
EB2	Exp Brd 2 - Fan Speed Cntl
HP	High Pressure Switch
IOEXP	I/O Expansion Board / Harness
ISO-NC	Isolation Valve - Normally Closed
ISO-NO	Isolation Valve - Normally Open
LED1	LED Annunciator / Harness
LED2	LED Annunciator / Harness
LP	Low Pressure Switch
LWT	Leaving Water Temp Sensor
MIII	MicroTech III Main Board
RAT	Return Air Temp Sensor
RV	Reversing Valve Solenoid
SLTS	Suction Line Temp Sensor
IB	ECM Interface Board
IB-1	ECM Interface Board Connection 1
IB-2	ECM Interface Board Connection 2
X1	Primary 24VAC Transformer
—	Standard Unit Wiring
- - -	Factory Installed Options

### Notes:

- Main Board Jumpers
    - JP2** Shorted for cycling fan
    - JP3** Geothermal
    - JP8** Shorted for IO Board Comm
  - IO Expansion Board Jumpers
    - All open for single stage compressor
- Transformer:**  
Unused wire to be capped.

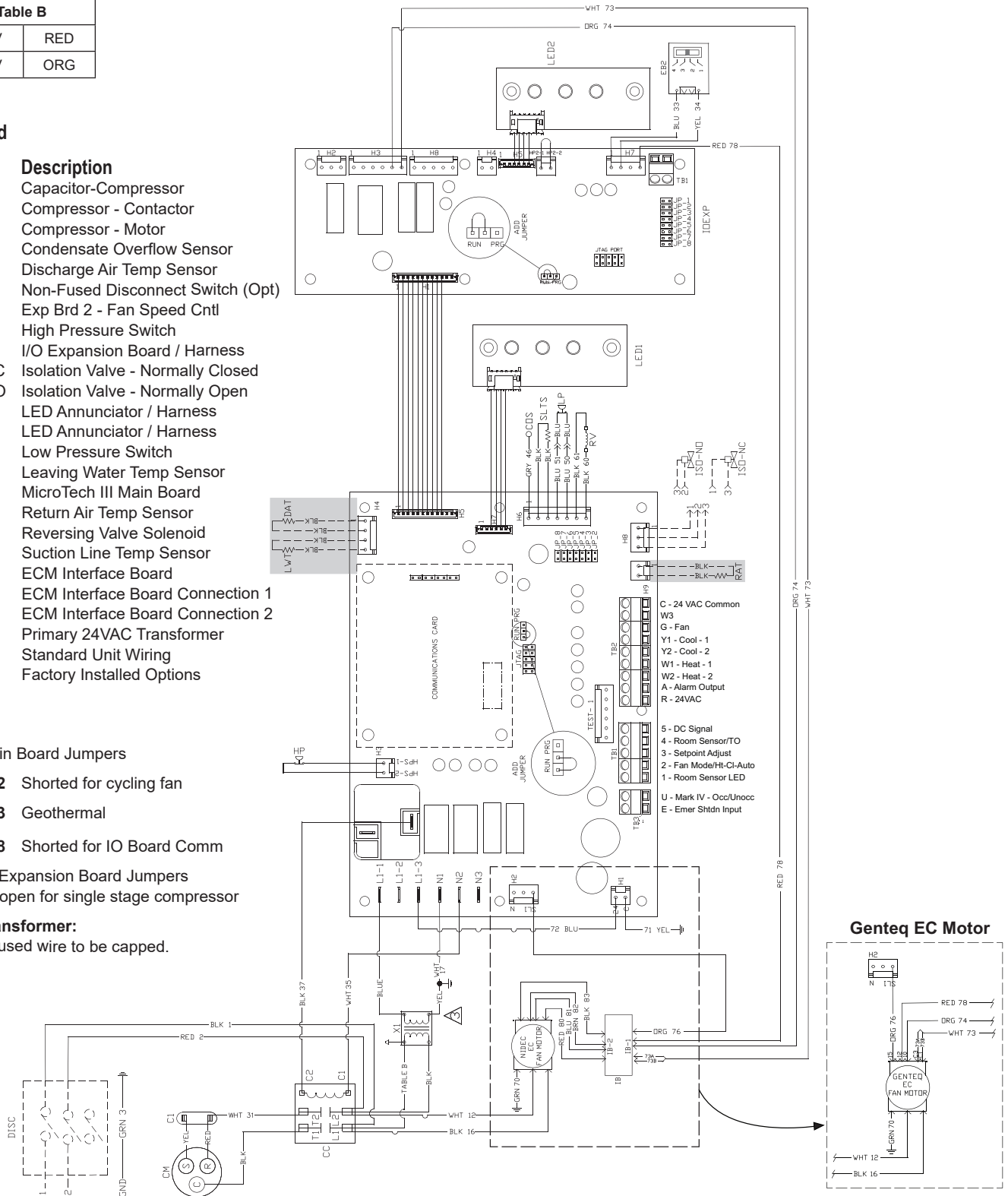

**Note:** Gray tint areas in wiring diagram: Units configured with a communication module include a Leaving Water (LWT), Discharge Air (DAT) and a Return Air (RAT) Temperature sensor. The DAT and RAT sensors are shipped loose inside the control box for field installation.

# MicroTech III Controller with EC Motor and Optional Communication

## Module – 460-60-3 Unit Sizes 024-070

Drawing No. With Nidec EC Motor (910269505) and Genteq EC Motor Detail (910168407)

Wiring diagrams are typical. For the latest drawing version refer to the wiring diagram located on the inside of the controls access panel of the unit.

Table B	
460V	BLK/RED

**Legend**

Item	Description
C1	Capacitor-Compressor
CC	Compressor - Contactor
CM	Compressor - Motor
COS	Condensate Overflow Sensor
DAT	Discharge Air Temp Sensor
DISC	Non-Fused Disconnect Switch (Opt)
EB2	Exp Brd 2 - Fan Speed Cntl
HP	High Pressure Switch
IOEXP	I/O Expansion Board / Harness
ISO-NC	Isolation Valve - Normally Closed
ISO-NO	Isolation Valve - Normally Open
IB	ECM Interface Board
IB-1	ECM Interface Board Connection 1
IB-2	ECM Interface Board Connection 2
LED1	LED Annunciator / Harness
LED2	LED Annunciator / Harness
LP	Low Pressure Switch
SLTS	Suction Line Temp Sensor
LWT	Leaving Water Temp Sensor
MIII	MicroTech III Main Board
RAT	Return Air Temp Sensor
RV	Reversing Valve Solenoid
X1	Primary 24VAC Transformer
—	Standard Unit Wiring
- - - -	Factory Installed Options

**Notes:**



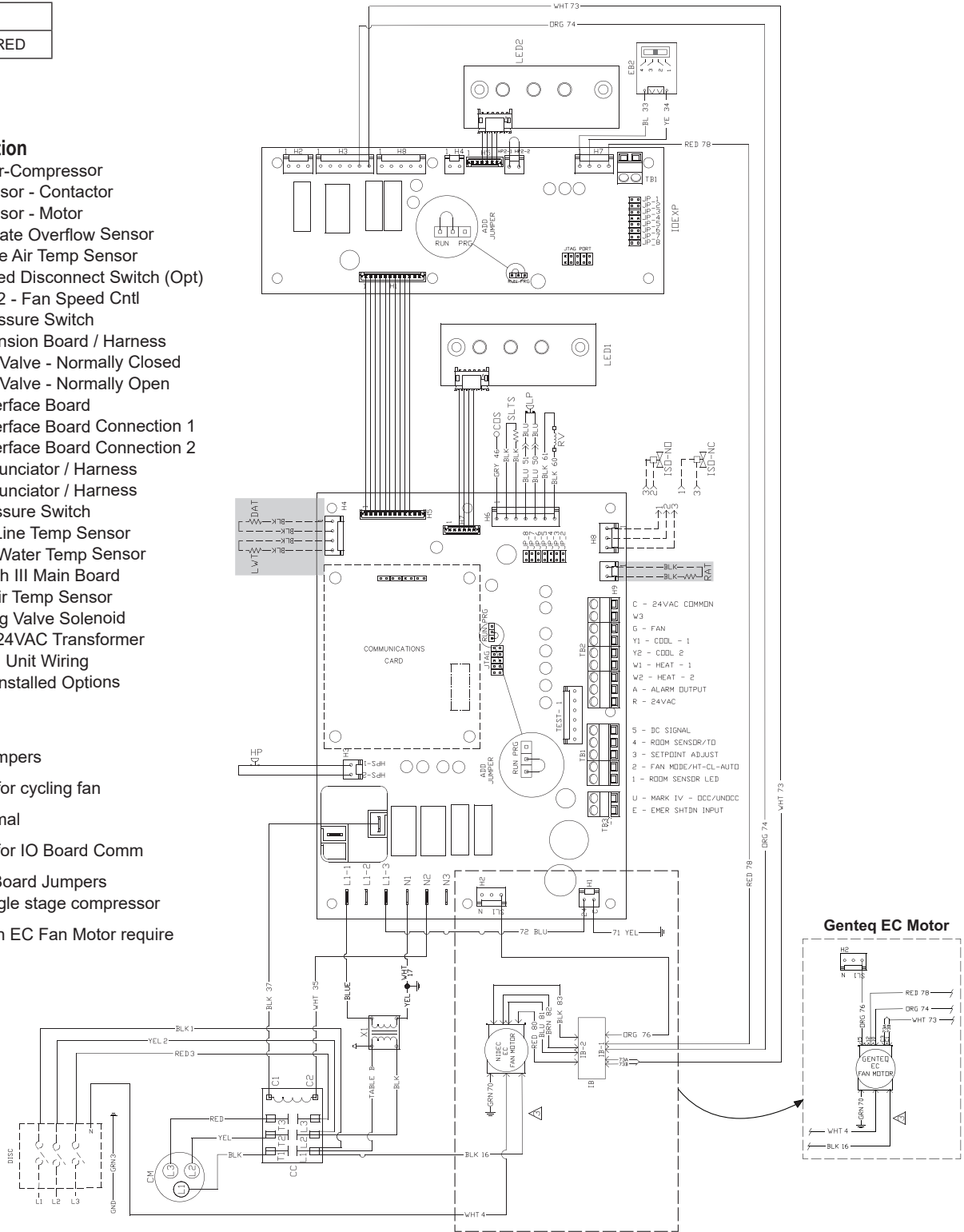

- Main Board Jumpers**
    - JP2** Shorted for cycling fan
    - JP3** Geothermal
    - JP8** Shorted for IO Board Comm
  - IO Expansion Board Jumpers**
    - All open for single stage compressor
- 3** 460V units with EC Fan Motor require a neutral wire.



**Note:** Gray tint areas in wiring diagram: Units configured with a communication module include a Leaving Water (LWT), Discharge Air (DAT) and a Return Air (RAT) Temperature sensor. The DAT and RAT sensors are shipped loose inside the control box for field installation.



# Thermostats and Remote Indoor Sensor

Table 17: Thermostat Selections

Wall Mounted Thermostats & Remote Sensor for use with all WSHP units: Console, V-Stack, Enfinity & SmartSource models		Thermostats				Remote Sensor	
		Non-Programmable	Programmable (7 Day or 5+1+1) Non-Programmable		7 Day Programmable Non-Programmable	Remote Indoor Thermostat Sensor	
		2H/2C	2H/2C	2H/3C Humidity Control	2H/3C Humidity Control WIFI		
							
Daikin Part Number		910411879	910411880	910417943	910417944	910420874	
Feature							
LCD Display	Room Temperature & Setpoint	•	•	•	•	Allows Remote Temperature Sensing	
	Room Humidity %			•	•		
Glow in the dark Display light		•	•	•	•		
Operating Modes	System	Heat-Off-Cool-Auto	Heat-Off-Cool-Auto	Heat-Off-Cool-Auto	Heat-Off-Cool-Auto		
	Fan	On-Auto	On-Auto	On-Auto-IAQ	On-Auto-IAQ		
Changeover	Manual	•	•	•	•		
	Auto	•	•	•	•		
Temperature Control Range		44° F to 90° F (7° C to 32° C)	44° F to 90° F (7° C to 32° C)	44° F to 90° F (7° C to 32° C)	44° F to 90° F (7° C to 32° C)	Use up to 16 sensors for temperature averaging	
Adjustable Setpoint Limits		•	•	•	•		
Keypad Lockout				•	•		
Filter Change Reminder			•	•	•		
Programmable Fan		•	•	•	•		
Power Type	Battery	2 AA Alkaline Batteries					
	Hardwire (Common Wire)	18 to 30 VAC	18 to 30 VAC	18 to 30 VAC	18 to 30 VAC		
Permanent Memory Retention		•	•	•	•		
Remote Indoor Sensor Capable (Requires Daikin P/N: 910420874)			•	•	•		
Terminals		Rh, RC, G, Y, Y2, C, O, B, W/E, W2	Rh, RC, C, Y, Y2, W/E, W2, G, B, O, S1, S2	Rh, RC, C, Y, Y2, W/E, W2, G, B, O, S1, S2, H, D	Rh, RC, C, Y, Y2, W/E, W2, G, B, O, S1, S2, H, D		
Application							
Dehumidification	Smart Dehumidification			•	•		
	Simplified	•	•	•	•		
	Humidistat Controlled			•	•		
Electric Heat	Boilerless	•	•	•	•		
	Supplemental	•	•	•	•		
	Primary	•	•	•	•		
Waterside Economizer		•	•	•	•		
Hydronic Heat		•	•	•	•		

# Room Temperature Sensors

**Table 18: Room Temperature Sensors for BAS Operation**

		Room Temperature Sensors			
		Basic Room Sensor	Cool to Warm Adjust	Digitally Adjustable Display Sensor	
		<b>Room Sensors for use with all WSHP units with a BACnet or LonWorks Communication Module: Console, V-Stack, Enfinity &amp; Smart-Source models</b>			
Temperature Sensing, LED Status Indication, Override/Reset Button	Cool/Warm Temperature Sensing Adjustment, LED Status Indication, Override/Reset Button		Temperature, Occupancy, Alarm, Setpoint and Status display, Override/Reset and Occupied/Unoccupied Buttons	Temperature, Humidity, Occupancy, Alarm, Setpoint and Status display, Override/Reset and Occupied/Unoccupied Buttons	
Daikin Part Number		910152149	910171464	910152147	910121754
Feature					
Setpoint Adjustment		None	Cool to Warm	Digitally Adjustable	Digitally Adjustable
Display	Room Temperature & Setpoint			•	•
	Room Humidity & Setpoint				•
Stages	Heating	4	4	4	4
	Cooling	3	3	3	3
Operating Modes	System				Heat-Off-Cool-Auto Dehumidify
	Fan				On-Auto
	Occupancy			LCD Display of Occupied-Unoccupied Icon	LCD Display of Occupied-Unoccupied Icon
Annunciation	Status LED	•	•	LCD Display of Unit Status	LCD Display of Unit Status
	LCD Alarm Display			•	•
Reset	Alarm	•	•	•	•
	Setback Override	•	•	•	•
Application					
Dehumidification	Smart Dehumidification				•
Electric Heat	Boilerless	•	•	•	•
	Supplemental	•	•	•	•
	Primary	•	•	•	•
Waterside Economizer		•	•	•	•
Hydronic Heat		•	•	•	•

**NOTICE**

For 50Hz units, it may be necessary to install a Ferrite Core Noise Suppressor on the thermostat cord cable where it enters the unit "Low Voltage" opening (see [Figure 39](#)). The Installer is responsible for checking local codes to determine if a Noise Suppressor is necessary to meet CE compliance.

**Figure 39: Ferrite Core Noise Suppressor on Thermostat Cord Cable**

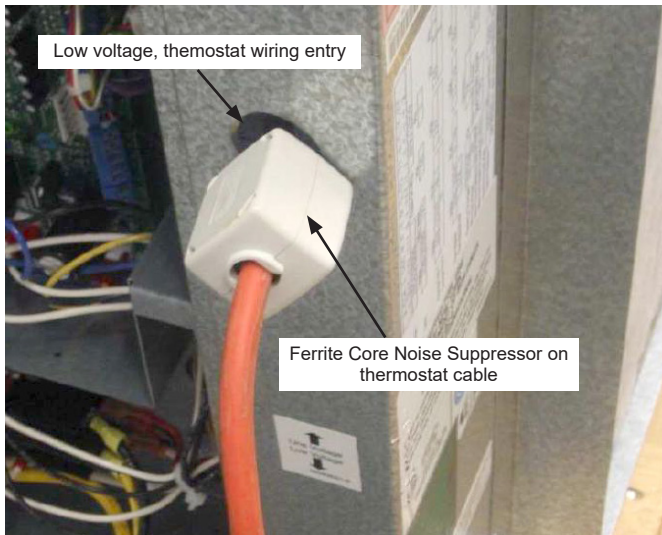

## Motorized Isolation Valve and Relay

The motorized valve kit is available as a field-installed accessory.

Wired as shown in Figure 40, the motorized valve will open on a call for compressor operation. Valves for unit sizes 007 to 024 are 1/2" while unit sizes 024 to 070 are 3/4".

Using a Normally Closed (N/C), power open valve, wire as illustrated in Figure 40.

Figure 40: Normally Closed, Power Open Motorized Valve

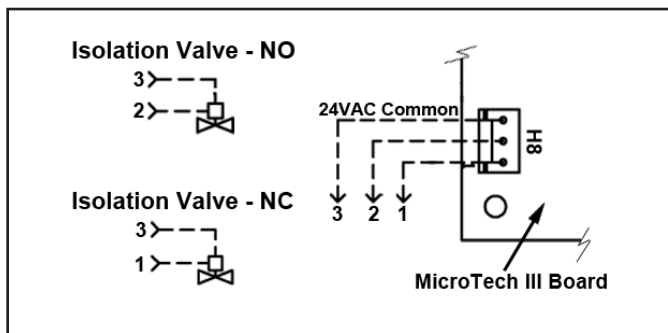
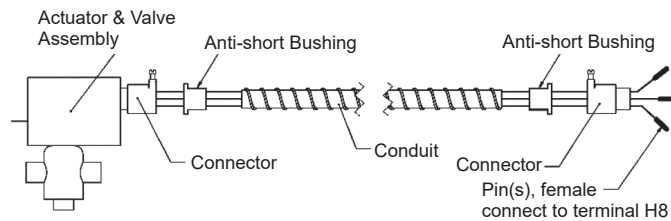

**Note:** Connectors on valve must be cut off and stripped back and the wires twisted to make connections to the IV/PR Terminals

## Pump Restart Relay Kit P/N 061419001

The MicroTech III unit controller has an internal Pump Restart Relay connected to H8, Pin 2 for the Normally Open (N/O) terminal of the internal relay.

Connect to H8, Pin 1 for the Normally Closed (N/C) terminal of the internal relay.

The output of the internal pump restart relay is 24-volts AC and the output is not available when the H8 connection is used to control a motorized valve.

## Multiple Unit Control (Up to 3 Units) (P/N 056794201)

The multiple unit control board is an accessory used when up to 3-units are controlled from a single thermostat. Typically the control panel and board is centrally mounted between the units and thermostat. A maximum of 2 boards may be used together if up to 6-units must be connected and controlled from a single thermostat. For detailed installation instructions refer to IM 952.

This version of the control uses VAC relays and should not be used in combination with any other accessories or equipment that require VDC connections.

Figure 41: Multiple Unit Control Panel and Board

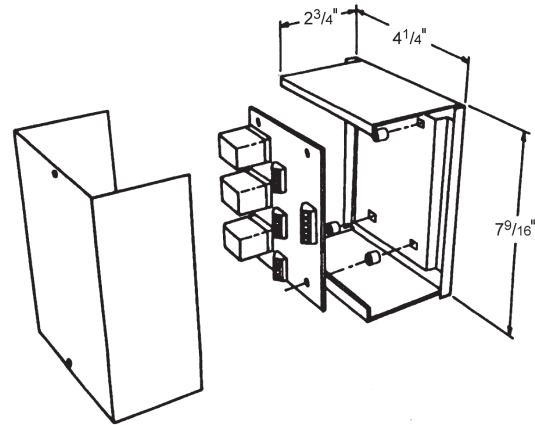

The multiple unit control board provides the components necessary to protect the MicroTech III unit controller from electrical damage that may occur when using standard off-the-shelf relays.

Do not use the unoccupied (U-terminal) feature with the multiple unit control board.

Figure 42: Wiring Multiple Unit Control Board (MUCP)

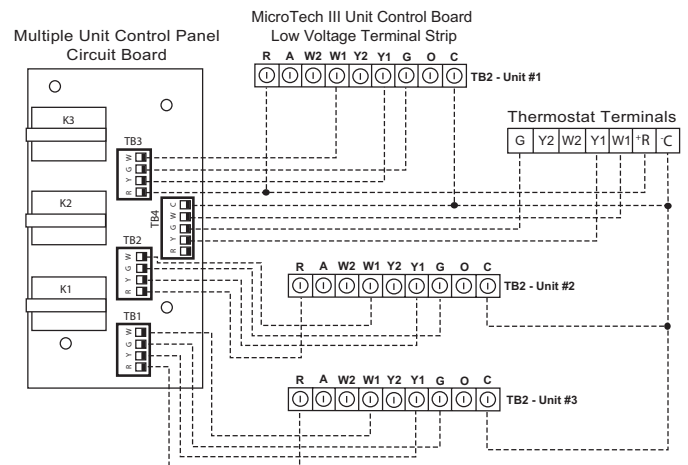

**Notes:** Dotted lines represent low voltage (Class II) wiring; a color-coded thermostat cable is recommended.

MUCP may be mounted horizontally or vertically on heat pump cabinet or any convenient surface. Do not use if using night setback. Thermostat must be A.C. voltage



## The In and Outs of R-410A

R-410A is a non-ozone depleting blend of two refrigerants - HFC-125 and HFC-32 in a fifty percent mixture. R-410A exhibits higher operating pressure and refrigeration capacity than R-22. R-410A is intended for use in new air conditioning applications that have traditionally been used HCFC-22 (R-22). Due to higher capacity and pressure of R-410A, it must not be used in existing R-22 systems.

Although R-410A is non-flammable at ambient temperature and atmospheric pressure, it can become combustible under pressure when mixed with air.

**Note:** *R-410A should not be mixed with air under pressure for leak testing. Pressure mixtures of dry nitrogen and R-410A can be used for leak testing.*

## Lubrication

R-410A should be used only with polyester (POE) oil. The HFC refrigerant components in R-410A will not be compatible with mineral oil or alkylbenzene lubricants. R-410A systems will be charged with the OEM recommended lubricant, ready for use with R-410A.

## Charging

Due to the zeotropic nature of R-410A, it should be charged as a liquid. In situations where vapor is normally charged into a system, a valve should be installed in the charging line to flash the liquid to vapor while charging.

Make certain that the recycle or recovery equipment used is designed for R-410A. The pressure of R-410A refrigerant is approximately 60 percent greater than that of R-22. Pressure gauges require a range up to 800 PSIG high side and 250 PSIG low side. Recovery cylinders require a 400 PSIG rating – do not put R-410A in a 300 PSIG rated cylinder.

### **WARNING**

Recycle/recovery equipment must be designated for R-410A. R-410A pressure is greater than R-22. Improper equipment can cause severe injury or death.

**Note:** *Because a water source heat pump operates under a wide range of water and air temperatures, the values printed below are to be taken as suggested pressure and temperatures.) All Daikin water source heat pumps are designed for commercial use. The units are designed for the cooling mode of operation and fail safe to cooling. The reversing valve is energized for the heating mode of operation.*

<b>Superheat</b>	<b>Head Pressure</b>	<b>Water Delta T</b>
8 to 14 degrees	335-355 PSIG	10° to 14°

**Note:** *All information above is based on ISO standard 13256-1 and tested at these conditions.*

## General Maintenance

1. Normal maintenance on all units is generally limited to filter changes. Units are provided with permanently lubricated motors and require no oiling even though oil caps may be provided.
2. Filter changes are required at regular intervals. The time period between changes will depend upon the project requirements. Some applications such as motels produce a lot of lint from carpeting and linen changes, and will require more frequent filter changes. Check filters at 60-day intervals for the first year until experience is acquired. If light cannot be seen through the filter when held up to sunlight or a bright light, it should be changed. A more critical standard may be desirable.
3. The condensate drain pan should be checked annually and cleaned and flushed as required.
4. Record performance measurements of volts, amps, and water temperature differences (both heating and cooling). A comparison of logged data with start-up and other annual data is useful as an indicator of general equipment condition.
5. Periodic lockouts almost always are caused by air or water problems. The lockout (shutdown) of the unit is a normal protective result. Check for dirt in the water system, water flow rates, water temperatures, airflow rates (may be a dirty filter), and air temperatures. If the lockout occurs in the morning following a return from night setback, entering air below machine limits may be the cause.

## MicroTech III Unit Controller LED Faults

**Table 19: Low Voltage Brownout or Emergency Shutdown**

Description	Type	Yellow	Green	Red
Low Voltage Brownout	Fault	OFF	Flash	OFF
Emergency Shutdown	Mode	OFF	Flash	OFF

\* Same LED display for both conditions

- Verify the E terminal is not connected to common. Remove wire, if connected, and LED should change to solid green only
- Confirm the low voltage supply is between 19-32VAC at the H1 terminal of the main board. If the low voltage supply is out of range, verify the unit supply voltage matches the nameplate voltage and the correct transformer primary wire has been selected

**Table 20: Compressor High Pressure**

Description	Type	Yellow	Green	Red
Compressor High Pressure	Fault	OFF	OFF	Flash

- Verify high pressure switch is connected to terminal H3 on the main board
- Check for continuity of the high pressure switch

If the high pressure fault resets when power is cycled

- Check water flow (cooling operation)
- Check airflow (heating operation)
- Entering water and air temperatures should be within the operating limits

**Table 21: Compressor Low Pressure**

Description	Type	Yellow	Green	Red
Compressor Low Pressure	Fault	OFF	OFF	ON

- Loose wire connection on low pressure circuit
- Failed low pressure switch
- Unit is low on charge

**Table 22: Compressor Suction Temp Fail, Room Temp Sensor Fail, Leaving Water Temp Sensor Fail**

Description	Type	Yellow	Green	Red
Compressor Suction Temp Sensor Fail	Fault	Flash	Flash	ON
Room Temp Sensor Fail (Room Sensor Control Only)	Fault	Flash	Flash	ON
Leaving Water Temp Sensor Fail	Fault	Flash	Flash	ON

- Check connection of low suction temperature sensor on terminal H6 pins 2 and 3
- Check resistance of low suction temperature sensor, leaving water temperature sensor, and room sensor or return air sensor. All sensors are 10kohm thermistor @77°F
- Return air sensor and room sensor shall not be connected simultaneously

**Table 23: Compressor Low Suction Temp**

Description	Type	Yellow	Green	Red
Compressor Low Suction Temp	Fault	Flash	OFF	OFF

- Check water flow (heating operation)
- Check airflow (cooling operation)
- Entering water and air temperatures should be within the operating limits

**Table 24: Low Entering Water Temp**

Description	Type	Yellow	Green	Red
Low Entering Water Temp (No Display with Boilerless EH)	Fault	Flash	OFF	Flash

- Low entering water temperature (below 35°F standard range or 13.5°F extended range)

**Table 25: Condensate Overflow**

Description	Type	Yellow	Green	Red
Condensate Overflow (Cooling & Dehumidification Modes Only)	Fault	ON	OFF	OFF

- Poor condensate drain
- Check the resistance to ground on condensate wire. This should be open if there is no water in the pan

**MicroTech III Unit Controller LED Faults (Continued)**

**Table 26: Serial EEPROM Corrupted**

Description	Type	Yellow	Green	Red
Serial EEPROM Corrupted	Fault	ON	ON	ON

- Cycle power to see if problem is corrected
- Replace main board, only if problem persists after power cycle

**Table 27: Service Test Mode Enabled**

Description	Type	Yellow	Green	Red
Service Test Mode Enabled	Mode	Flash	Flash	Flash

- Jumper JP1 is shorted for service test mode operation. Note: Used only for testing purposes, control timing may damage actual hardware

**Table 28: Unoccupied Mode**

Description	Type	Yellow	Green	Red
Unoccupied Mode	Mode	ON	ON	OFF

- Terminal U on main control board is connected to common from external source, or the network is overriding occupancy mode

**Table 29: Occupied, Bypass Mode, Standby or Tenant Override Modes**

Description	Type	Yellow	Green	Red
Occupied, Bypass Mode, Standby or Tenant Override Modes	Mode	OFF	ON	OFF

- Unit is operating normal. It may currently have a control signal or ready to operate when a control signal is active

**I/O Expansion Module LED Faults (For Units with Optional Boilerless Electric Heat)**

**Table 30: Invalid Jumper Configuration**

Description	Type	Yellow	Green	Red
Invalid Jumper Configuration	Fault	Flash	Flash	OFF

- Verify jumper settings

**Table 31: Baseboard Communication Fail**

Description	Type	Yellow	Green	Red
Baseboard Communication Fail	Fault	OFF	Flash	Flash

- Verify connection of cable between H5 on main board and H1 on I/O expansion board

**Table 32: Entering Water Temp Sensor Fail (Boilerless Electric Heat or Waterside Economizer Only)**

Description	Type	Yellow	Green	Red
Entering Water Temp Sensor Fail (Boilerless Electric Heat or Waterside Economizer Only)	Fault	Flash	Flash	ON

- Verify connections at terminals H4 on the I/O expansion board
- Verify resistance of EWT thermistor is 10K @ 77°F

**Table 33: Low Entering Water Temperature (No Display On Boilerless Electric Heat)**

Description	Type	Yellow	Green	Red
Low Entering Water Temperature (No Display On Boilerless Electric Heat)	Fault	OFF	ON	Flash

- Verify entering water temperature is greater than set point

**I/O Expansion Module LED Faults (For Units with Optional Boilerless Electric Heat) (Continued)**

**Table 34: High Pressure Circuit #2**

Description	Type	Yellow	Green	Red
High Pressure Circuit #2	Fault	OFF	OFF	Flash

- Verify high pressure switch is connected to terminal H6 on the I/O Expansion board
- Check for continuity of the high pressure switch

If the high pressure fault resets when power is recycled:

- Check water flow (cooling operation)
- Check airflow (heating operation)
- Entering water and air temperatures should be within the operating limits

**Table 35: Low Pressure Circuit #2**

Description	Type	Yellow	Green	Red
Low Pressure Circuit #2	Fault	OFF	OFF	ON

- Loose wire connection on low pressure circuit
- Failed low pressure switch
- Unit is low on charge

**Table 36: Low Suction Temp #2**

Description	Type	Yellow	Green	Red
Low Suction Temp #2	Fault	Flash	OFF	OFF

- Check water flow (heating operation)
- Check airflow (cooling operation)
- Entering water and air temperatures should be within the operating limits

**Table 37: Compressor Suction Temp Sensor Fail circuit #2**

Description	Type	Yellow	Green	Red
Compressor Suction Temp Sensor Fail circuit #2	Fault	Flash	Flash	ON

- Check connection of low suction temperature sensor
- Check resistance of low suction temperature sensor, leaving water temperature sensor, and room sensor or return air sensor. All sensors are 10kohm thermistor @77°F

## Troubleshooting Refrigeration Circuit

*Figure 43: Troubleshooting Refrigeration Circuit*

Symptom	Head Pressure	Suction Pressure	Compressor Amp Draw	Super Heat	Subcooling	Air Temp Differential	Water (loops) Temp Differential	Safety Lock Out
<b>Charge</b> Undercharge System (Possible Leak)	Low	Low	Low	High	Low	Low	Low	Low Pressure
Overcharge System	High	High	High	Normal	High	Normal	Normal	High Pressure
						Low		
Low Air Flow Heating	High	High	High	High	Low	High	Low	High Pressure
				Normal				
Low Air Flow Cooling	Low	Low	Low	Low	High	High	Low	Low Temp
				Normal				
Low Water Flow Heating	Low	Low	Low	Low	High	Low	High	Low Temp
	Normal	Normal						
Low Water Flow Cooling	High	High	High	High	Low	Low	High	High Pressure
High Air Flow Heating	Low	Low	Low	Low	High	Low	Low	Low Temp
High Air Flow Cooling	Low	High	Normal	High	Low	Low	Normal	High Pressure
High Water Flow Heating	Normal	Low	Normal	High	Normal	Normal	Low	High Pressure
High Water Flow Cooling	Low	Low	Low	Low	High	Normal	Low	Low Temp
TXV Restricted	High	Low	Normal	High	High	Low	Low	
			Low					

# Troubleshooting the Water Source Heat Pump Unit

Figure 44: Troubleshooting Guide - Unit Operation

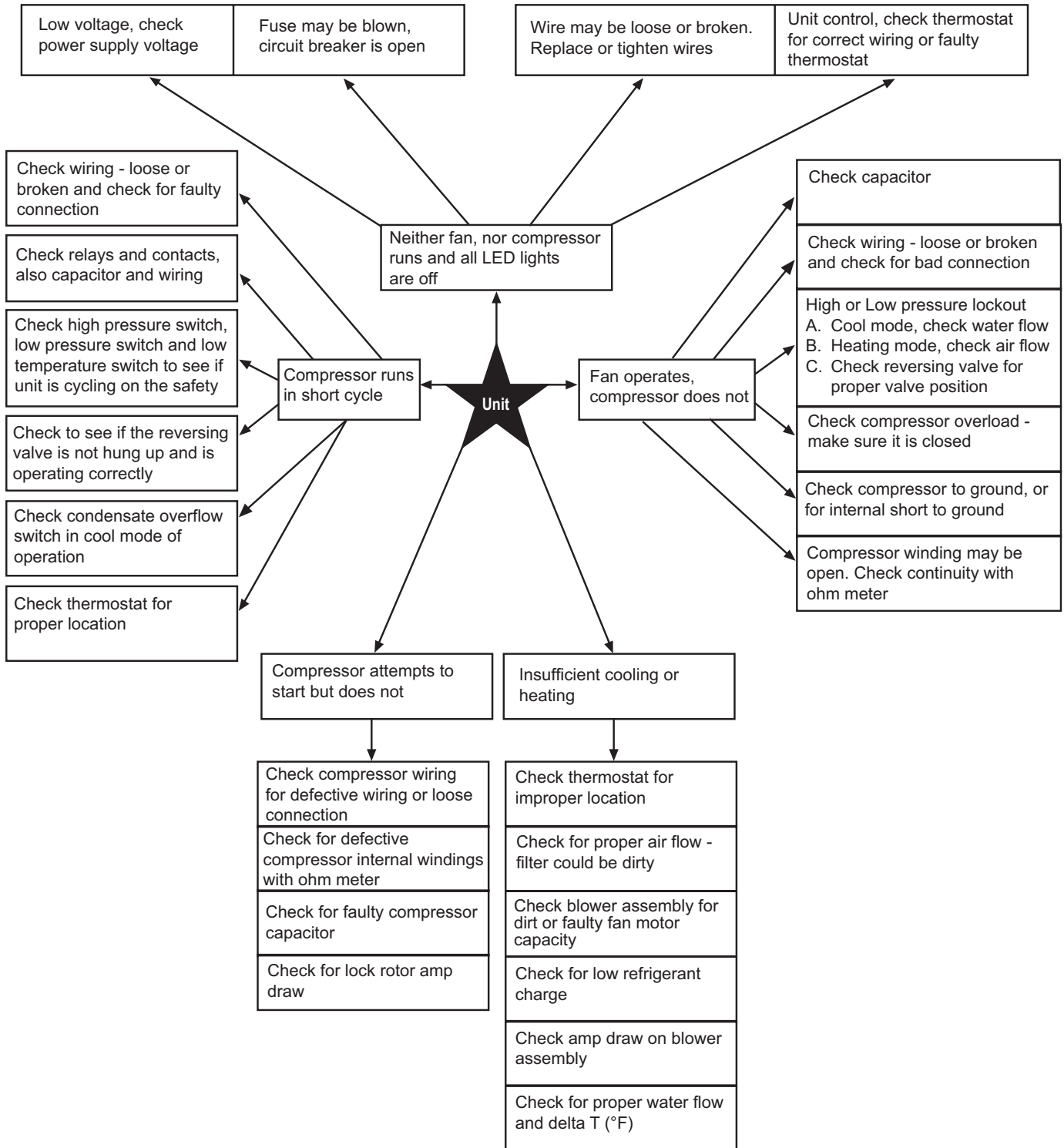



**Figure 45: Cooling Mode – (Single Circuit Only Shown)**

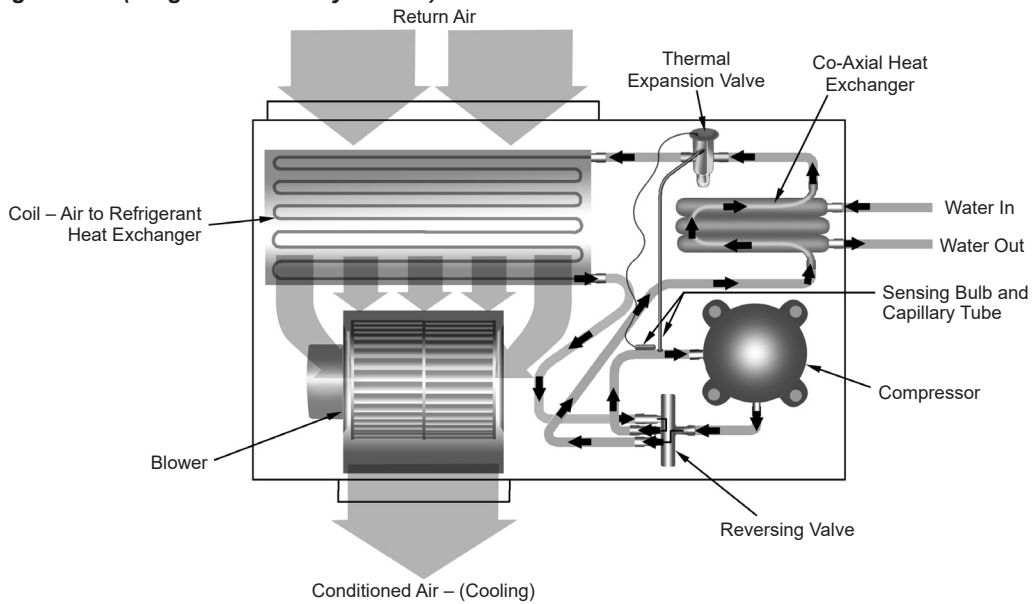

## Cooling Refrigeration Cycle

When the wall thermostat is calling for COOLING, the reversing valve directs the flow of the refrigerant, a hot gas, leaving the compressor to the water-to-refrigerant heat exchanger. Here the heat is removed by the water and the hot gas condenses to become a liquid. The liquid then flows through a thermal expansion metering system to the air-to-refrigerant heat exchanger coil. The liquid then evaporates becoming a gas, at the same time absorbing heat and cooling the air passing over the surfaces of the coil. The refrigerant then flows as a low pressure gas through the reversing valve and back to the suction side of the compressor to complete the cycle.

**Figure 46: Heating Mode – (Single Circuit Only Shown)**

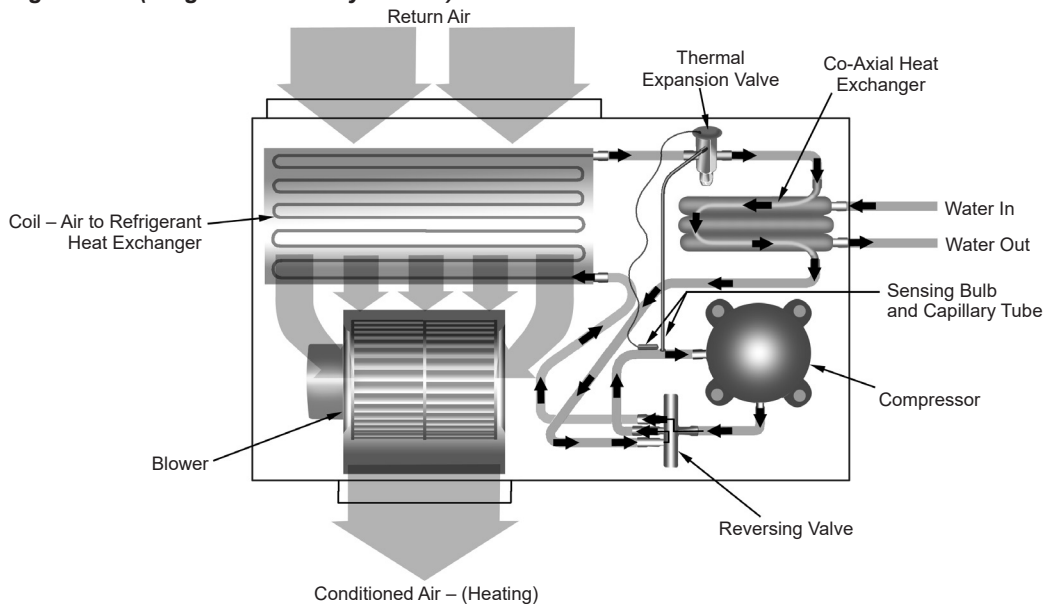

## Heating Refrigeration Cycle

When the wall thermostat is calling for HEATING, the reversing valve directs the flow of the refrigerant, a hot gas, leaving the compressor to the air-to-refrigerant heat exchanger coil. Here the heat is removed by the air passing over the surfaces of the coil and the hot gas condenses to become a liquid. The liquid then flows through a capillary thermal expansion metering system to the water-to-refrigerant heat exchanger. The liquid then evaporates becoming a gas, at the same time absorbing heat and cooling the water. The refrigerant then flows as a low pressure gas through the reversing valve and back to the suction side of the compressor to complete the cycle.

**DANGER**

To avoid electrical shock, personal injury or death, be sure that field wiring complies with local and national fire, safety, and electrical codes, and voltage to the system is within the limits shown in the job-specific drawings and unit electrical data plate(s). Power supply to unit must be disconnected when making field connections. To avoid electrical shock, personal injury or death, be sure to rigorously adhere to field wiring procedures regarding proper lockout and tagout of components.

## General Use and Information

The Microtech III unit controller is provided with two drive terminals, R(24VAC) and C(0 VAC) that can be used by the end user to drive the thermostat inputs (G, Y1, Y2, W1, and W2) and control inputs (U, E, and O). Any combination of a single board drive terminal (R or C) may be used to operate the MicroTech III unit controller's control or thermostat inputs. However, only one drive terminal (R or C) can be connected to any individual input terminal or damage may result. Some control inputs are not accessible to the end user (for example, HP, LP, SLTS, and COF).

Typically the Microtech III unit controller's R (24VAC) terminal is used to drive the board's thermostat inputs and control inputs by connecting it to the R terminal of an industry standard thermostat. The control outputs of the standard thermostat are then connected to the Microtech III unit controller thermostat inputs and control inputs as needed. Any remaining board input(s) may be operated by additional thermostat outputs or remote relays (dry contacts only).

All Microtech III unit controller inputs must be operated by dry contacts powered by the control board's power terminals. No solid state devices (Triacs) may be used to operate the Microtech III unit controller inputs. No outside power source may be used to operate the Microtech III unit controller inputs.





## Unit Check / Equipment Data

### Installation Data

Job Name \_\_\_\_\_ Check Test Date: \_\_\_\_\_

City \_\_\_\_\_ State \_\_\_\_\_ Zip \_\_\_\_\_

Daikin Model # \_\_\_\_\_

Daikin Serial # \_\_\_\_\_ Job site Unit ID # (HP #) \_\_\_\_\_

General Contractor: \_\_\_\_\_ Mechanical Contractor: \_\_\_\_\_

Technician Performing Start-Up: Name \_\_\_\_\_ Employer: \_\_\_\_\_

**Complete equipment data from measurements taken at the locatons indicated on the drawing below.**

### Equipment Data

**Flow Rate** **EWP - LWP = ΔP**

① EWP - PSI In \_\_\_\_\_ minus      ② LWP - PSI Out \_\_\_\_\_ equals ΔP \_\_\_\_\_

The first step in finding GPM is to subtract leaving water pressure from entering water pressure. The difference between the two is referred to as ΔP. ΔP can be converted to GPM by looking in the equipment specification catalog.

**Caution ΔP ≠ GPM**

**Note: A conversion table must be used to find GPM from (Delta) ΔP measurements.**

**Loop Fluid Temperature Rise / Drop through Coaxial Heat Exchanger** **EWT - LWT = ΔT**

③ EWT - °F Out \_\_\_\_\_ minus      ④ LWT - °F Out \_\_\_\_\_ equals Fluid ΔT \_\_\_\_\_

ΔT is the rise or drop in the fluid temperature as it passes through the Coaxial.

**Air Temperature Rise / Drop through the air coil** **ΔT x CFM x 1.08 = BTUH Sensible**

⑤ EAT - °F In \_\_\_\_\_ minus      ⑥ LAT - °F Out \_\_\_\_\_ equals Air ΔT \_\_\_\_\_

**Note: Perform Check, Test and Start-Up in the Cooling Mode Only.**

EWT - Entering Water Temperature	EWP - Entering Water Pressure	EAT - Entering Air Temperature	Δ- Delta (Differential)
LWT - Leaving Water Temperature	LWP - Leaving Water Pressure	LAT - Leaving Air Temperature	CFM - Cubic Feet/Minute
			BTUH - British Thermal Units/Hour

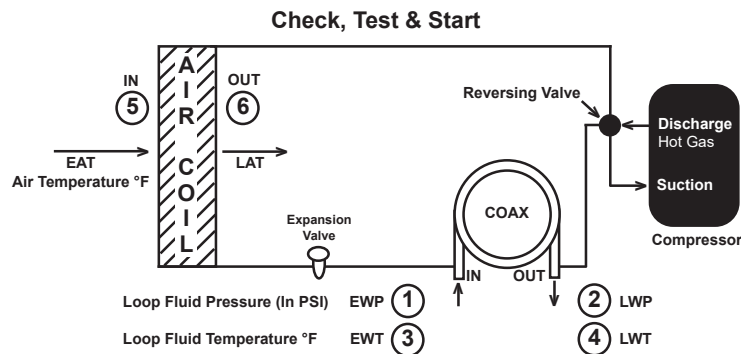



### Commercial Check, Test and Start Worksheet

*(Complete all equipment measurements indicated for each unit per installation on page 2)*

	Model	Serial #	H.P. #	EWT ③	LWT ④	EWP ①	LWP ②	EAT ⑤	LAT ⑥	Volts	Amps Cooling	Check Air Filter and Coil	Comments (more comments on back)
1.													
2.													
3.													
4.													
5.													
6.													
7.													
8.													
9.													
10.													
11.													
12.													
13.													
14.													
15.													
16.													
17.													
18.													
19.													
20.													
21.													
22.													
23.													
24.													
25.													
26.													
27.													
28.													
29.													
30.													
31.													
32.													
33.													
34.													
35.													
36.													
37.													
38.													
39.													
40.													
41.													
42.													









### ***Daikin Applied Training and Development***

Now that you have made an investment in modern, efficient Daikin equipment, its care should be a high priority. For training information on all Daikin HVAC products, please visit us at [www.DaikinApplied.com](http://www.DaikinApplied.com) and click on Training, or call 540-248-9646 and ask for the Training Department.

### ***Warranty***

All Daikin equipment is sold pursuant to its standard terms and conditions of sale, including Limited Product Warranty. Consult your local Daikin Applied representative for warranty details. Refer to Form 933-430285Y. To find your local Daikin Applied representative, go to [www.DaikinApplied.com](http://www.DaikinApplied.com).

### ***Aftermarket Services***

To find your local parts office, visit [www.DaikinApplied.com](http://www.DaikinApplied.com) or call 800-37PARTS (800-377-2787).  
To find your local service office, visit [www.DaikinApplied.com](http://www.DaikinApplied.com) or call 800-432-1342.

This document contains the most current product information as of this printing. For the most up-to-date product information, please go to [www.DaikinApplied.com](http://www.DaikinApplied.com).

Products manufactured in an ISO Certified Facility.