

Installation and Maintenance Manual

IM 1084-3

Group: **Applied Terminal Systems**

Part Number: **IM1084-3**

Date: **April 2024**

MicroTech® III and MT2300 Boilerless System Kit for use with all MicroTech III and MT2300 Controlled Water Source Heat Pumps

Description

The Boilerless System Kit provides the necessary hardware to provide control of a field-supplied and installed electric duct heater for emergency (boilerless) electric heat.

Note: *This kit will not allow simultaneous operation of both the compressor and electric heater.*

The kit is designed for use only with select Daikin water source heat pumps.

The controller monitors water supply temperature using an Entering Water Temperature (EWT) Sensor. On a call for heating, when the entering water temperature is below set point, the controller will disable the compressor, start the fan1 and energize a 24VAC output for use with a field-supplied relay. The field-supplied relay must be selected to have contacts sized to function with the field-provided electric duct heater control circuit.

¹ *Fan operation may be either cycled or continuous with use of a thermostat with a fan setting switch.*

Small Enfinity WSHP units without an I/O expansion module – kit p/n 910110355

This kit includes the parts and quantities as described below. Please make sure all contents are present before beginning the installation procedure.

Description	Quantity
MicroTech III I/O Expansion Module	1
Standoff 7/16	6
Assembly, Harness ELEC HT- H8 to Relay	1
Assembly, EWT Sensor	1
Prestite Insulation	1
Clamp	1
Diagram - BSK	1
Instruction, Component Placement	1
IM 1084	1

SmartSource units and small Enfinity units with an I/O expansion module – kit p/n 910110353

This kit includes the parts and quantities as described below. Please make sure all contents are present before beginning the installation procedure.

Description	Quantity
Assembly, Harness ELEC HT- H8 to Relay	1
Assembly, EWT Sensor	1
Prestite Insulation	1
Clamp	1
Diagram - BSK	1
Instruction, Component Placement	1
IM 1084	1

DANGER



Disconnect all electrical power before servicing unit. Electrical shock will cause severe injury or death.

WARNING

To avoid electrical shock, personal injury or death:

1. Installer must be qualified, experienced technician.
2. Disconnect power supply before installation to prevent electrical shock and damage to equipment.

CAUTION

Sharp edges can cause personal injury. Avoid contact with them.

Procedure for small horizontal Enfinity units sizes 007-070

1. Install the entering water temperature sensor to the supply water pipe with provided clamp as shown in [Figure 1](#). Wrap the entering water temperature sensor with Prestite insulation.
2. Install the I/O expansion module (if provided with kit) to the MicroTech III control box using provided stand-offs (see [Figure 2](#) and [Figure 3](#)).

Note: *The I/O expansion module will be located on the bottom of the control box if the control box is located to the left and mounted to the top if the control box is mounted to the right.*

3. Refer to [Figure 3](#) and connect the I/O expansion module harness to terminal H5 on the MicroTech III controller and terminal H1 on the I/O expansion module.
4. Pass the entering water temperature sensor wire through the control box hole as shown in [Figure 2](#) and connect to terminal H4 on the I/O expansion module as shown in [Figure 3](#).

5. Apply the provided schematic label to the inside of the compressor compartment access panel (or other suitable location) for future reference.
6. Connect the electric heat harness plug, wires #84 and #85 to terminal H8 on the I/O expansion module ([Figure 3](#)). Route the wires out through the low voltage hole on the unit corner post. Connect the wires to the duct heater control per applicable electrical codes.

Note: *The I/O expansion module software version and MicroTech III controller software version must be compatible. Units not having an I/O expansion module may need to have the software version for the MicroTech III controller updated to a newer version. For compatibility information contact the controls department in Minneapolis, MN (1-866-462-7829).*

Figure 1: Compressor compartment and sensor placement detail for small horizontal Enfinity unit

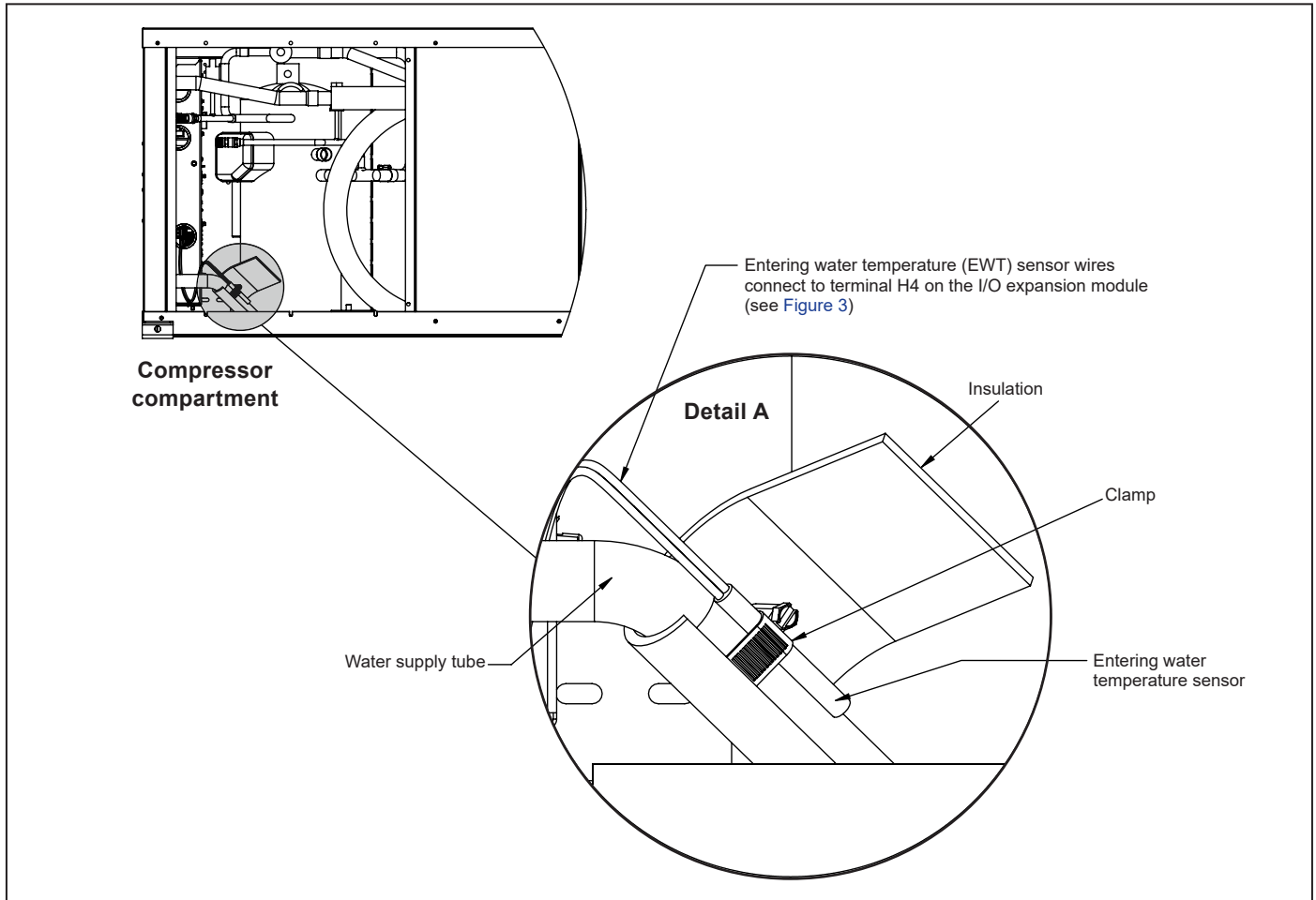
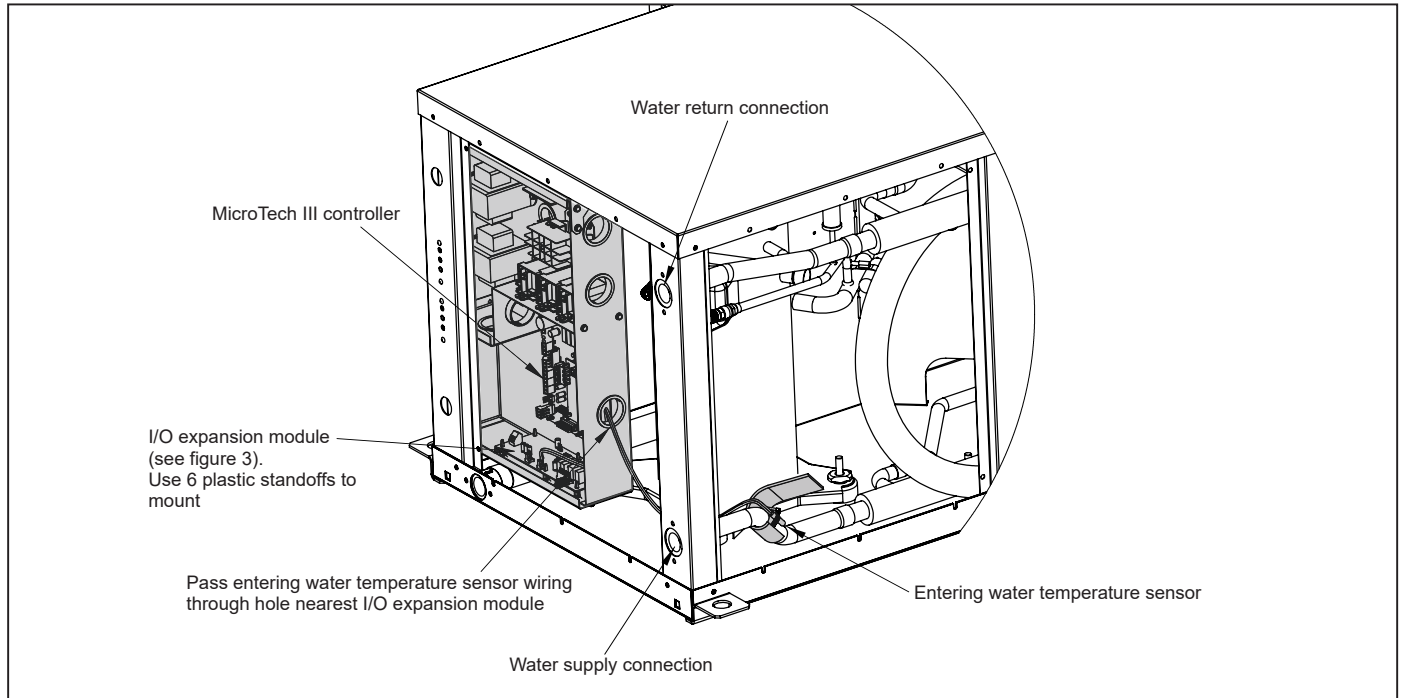
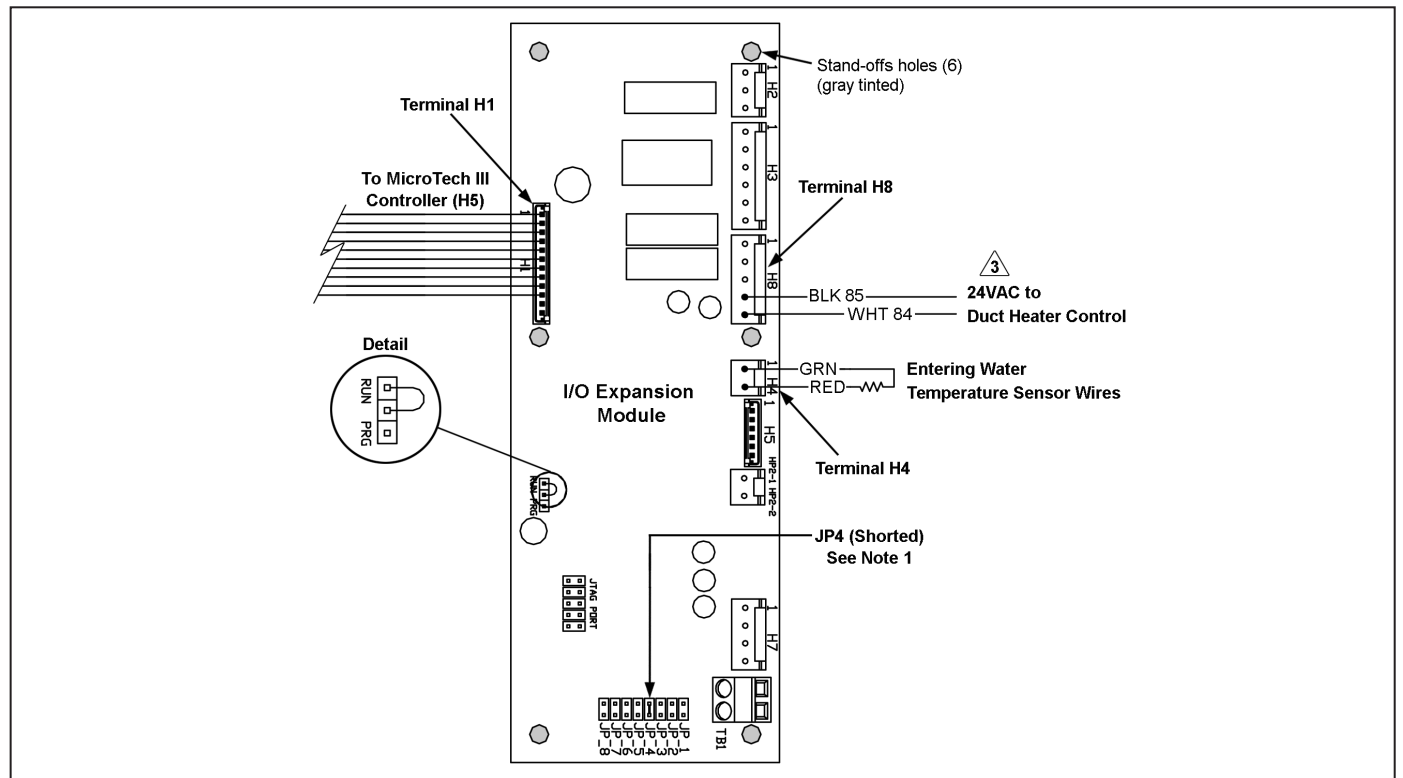

Figure 2: Control box location and sensor location detail for small horizontal Enfinity unit



- Notes:**
1. The I/O expansion module will be located on the bottom of the control box if the control box is located to the left and mounted to the top if the control box is mounted to the right.
 2. Confirm on the MicroTech III controller that the JP3 jumper is configured correctly:
Standard operation = Open, Geothermal operation = Shorted

Figure 3: I/O expansion module terminal connection detail for small horizontal Enfinity unit



- Notes:**
1. I/O expansion module jumpers – must be JP3 (Open), JP4 (Shorted)
 2. I/O expansion module software version and MicroTech III controller software version must be compatible.
- ⚠ Relay output – SPST (N/O contacts [Form A] minimum 500mA @ 24VAC class II, 100,000 cycles).

Large capacity WSHP units with two compressors – kit p/n 910167211

This kit includes the parts and quantities as described below. Please make sure all contents are present before beginning the installation procedure.

Description	Quantity
Assembly, harness electric heat - H2 to relay	1
Assembly, EWT sensor	1
Prestite insulation	1
Clamp	1
Diagram - BSK	1
Cable Tie Base	1
Cable Tie	1
Bushing	1
Instruction, component replacement	1
IM 1084	1

Procedure for large capacity Enfinity horizontal units – sizes 072-120

1. Install the entering water temperature sensor to the supply water pipe with provided clamp as shown in Figure 4. Wrap the entering water temperature sensor with Prestite insulation.
2. Pass the entering water temperature sensor wire through the control box hole located nearest the I/O expansion module as shown in Figure 5.

⚠ CAUTION

Do not route the sensor wire so that it comes in contact with unit components that are predisposed to movement when operating, as wire wear can occur. Use the provided wire tie base and wire tie if required.

3. Apply the provided schematic label to the inside of the compressor compartment access panel (or other suitable location) for future reference.
4. Connect the electric heat harness plug, wires #84 and #85 to terminal H2 on the I/O expansion module (Figure 6).
5. Route the wires out through the low voltage hole on the unit corner post. If the low voltage hole does not have a bushing, place the provided bushing in the hole. Connect the wires to the duct heater control per applicable electrical codes.

Note: *MicroTech III controller software version and the I/O expansion module software version must be compatible. The MicroTech III unit control board and I/O expansion module must be SmartSource two-compressor software. For compatibility information contact the controls department in Minneapolis, MN (1-866-462-7829).*

Figure 4: Compressor compartment and sensor placement detail for large capacity horizontal Enfinity unit

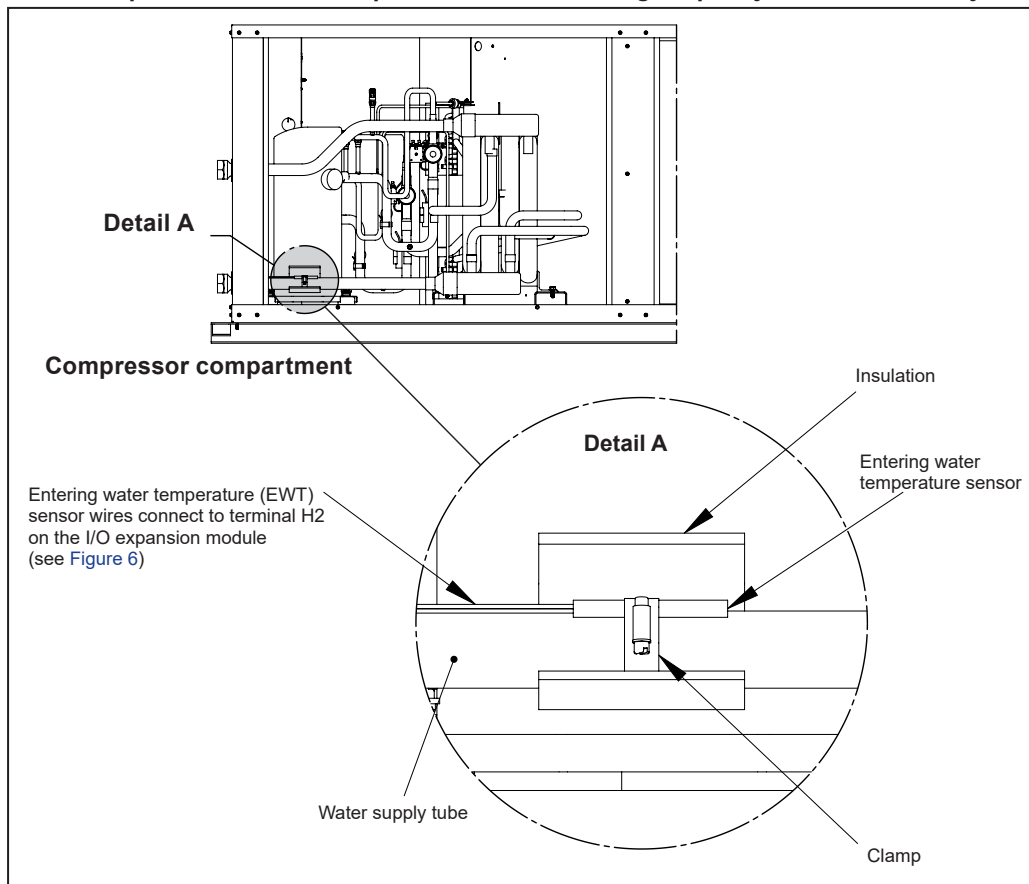

Figure 5: Control box location and sensor location detail for large capacity horizontal Enfinity unit

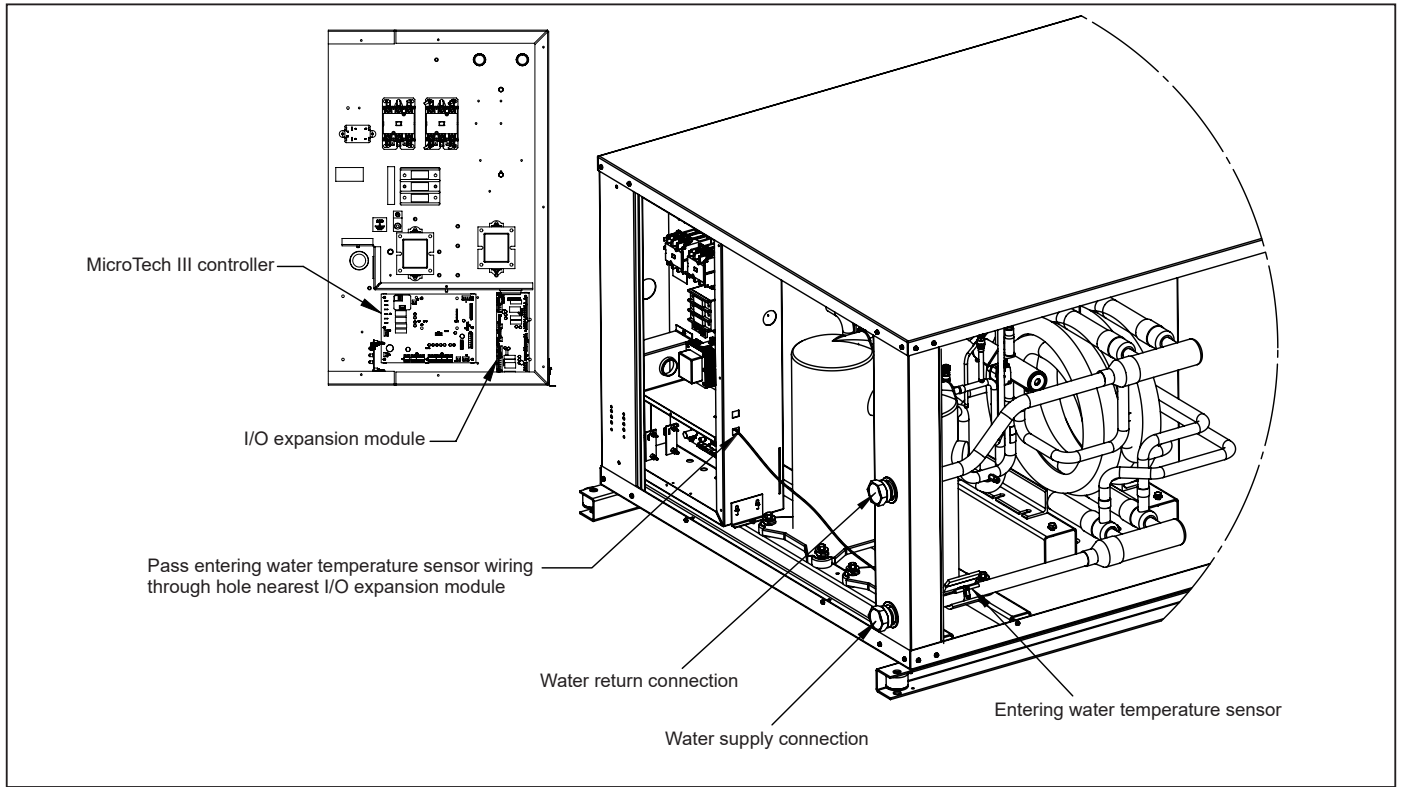
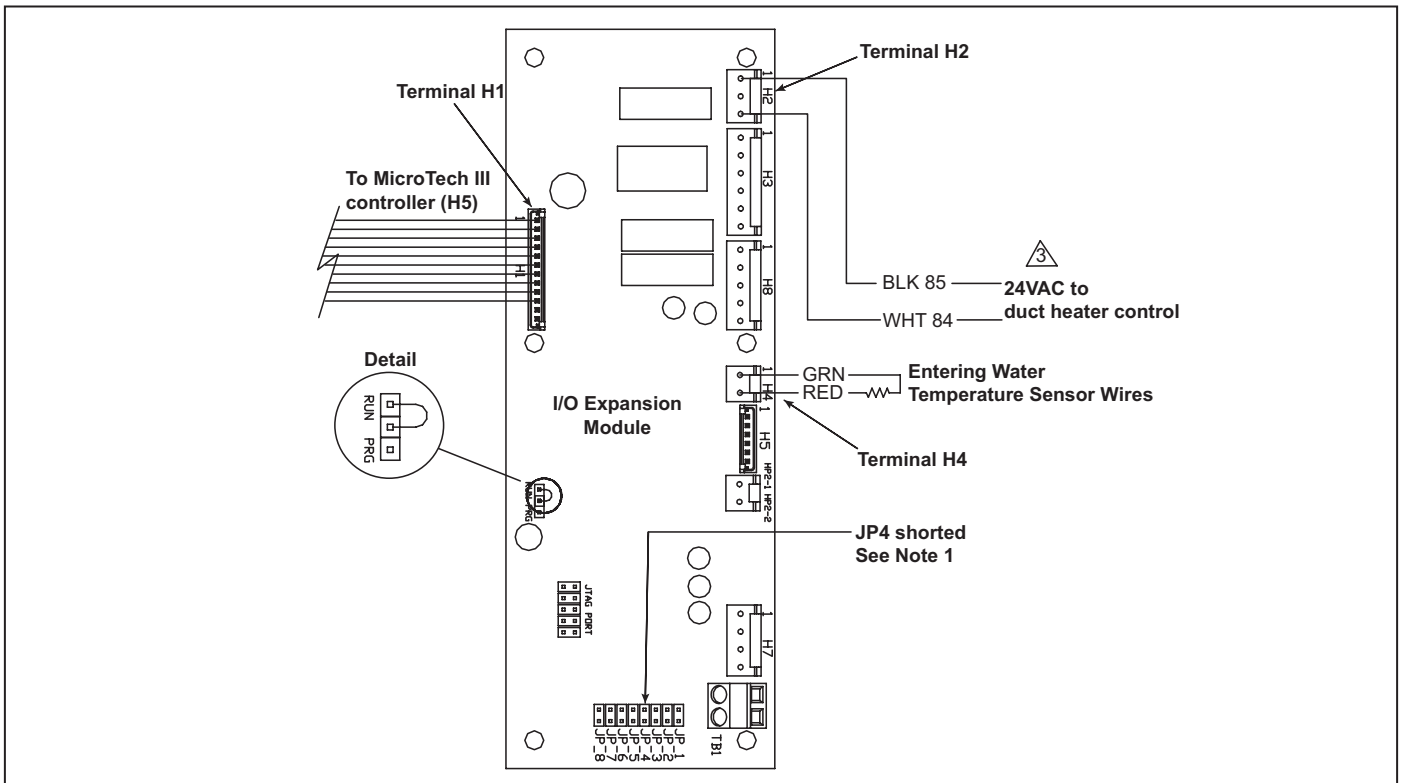

Figure 6: I/O expansion module terminal connection detail for large capacity horizontal and vertical Enfinity units



Notes:

1. I/O expansion module jumpers: – JP4 for boilerless electric heat
 2. MicroTech III controller software version and the I/O expansion module software version must be compatible. The MicroTech III unit control board and I/O expansion module must be SmartSource two-compressor software.
- ⚠ Relay output – SPST (N/O contacts [Form A] minimum 500mA @ 24VAC class II, 100,000 cycles).

Procedure for large capacity vertical Enfinity units – sizes 072-290

1. Install the entering water temperature sensor to the supply water pipe with provided clamp as shown in Figure 7. Wrap the entering water temperature sensor with Prestite insulation.
2. Route the sensor wire back to the control box, I/O expansion module along the most appropriate path.

⚠ CAUTION

Do not route the sensor wire so that it comes in contact with unit components that are predisposed to movement when operating, as wire wear can occur.

3. Pass the entering water temperature sensor wire through the control box hole located nearest the I/O expansion module as shown in Figure 8.
4. Apply the provided schematic label to the inside of the compressor compartment access panel (or other suitable location) for future reference.

5. Connect the electric heat harness plug, wires #84 and #85 to terminal H2 on the I/O expansion module (see Figure 6).
6. Route the wires out through the low voltage hole on the unit corner post. If the low voltage hole does not have a bushing, place the provided bushing in the hole. Run the wires up the corner post to the top of the unit, securing it with the provided wire tie base and wire tie. Connect the wires to the duct heater control per applicable electrical codes.

Note: *MicroTech III controller software version and the I/O expansion module software version must be compatible. The MicroTech III unit control board and I/O expansion module must be SmartSource two-compressor software. For compatibility information contact the controls department in Minneapolis, MN (1-866-462-7829).*

Figure 7: Unit back view compartment and sensor placement detail for large capacity vertical Enfinity unit

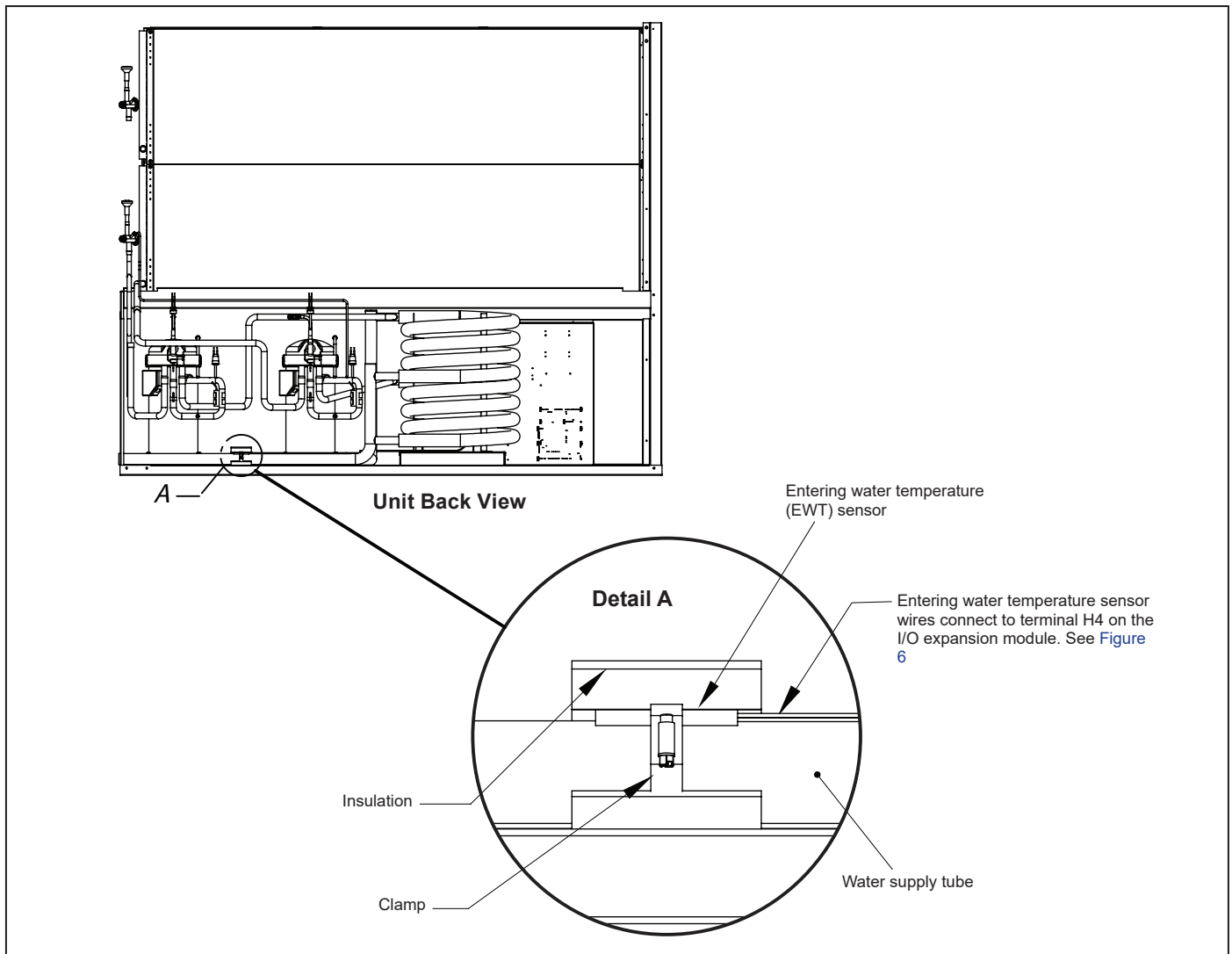
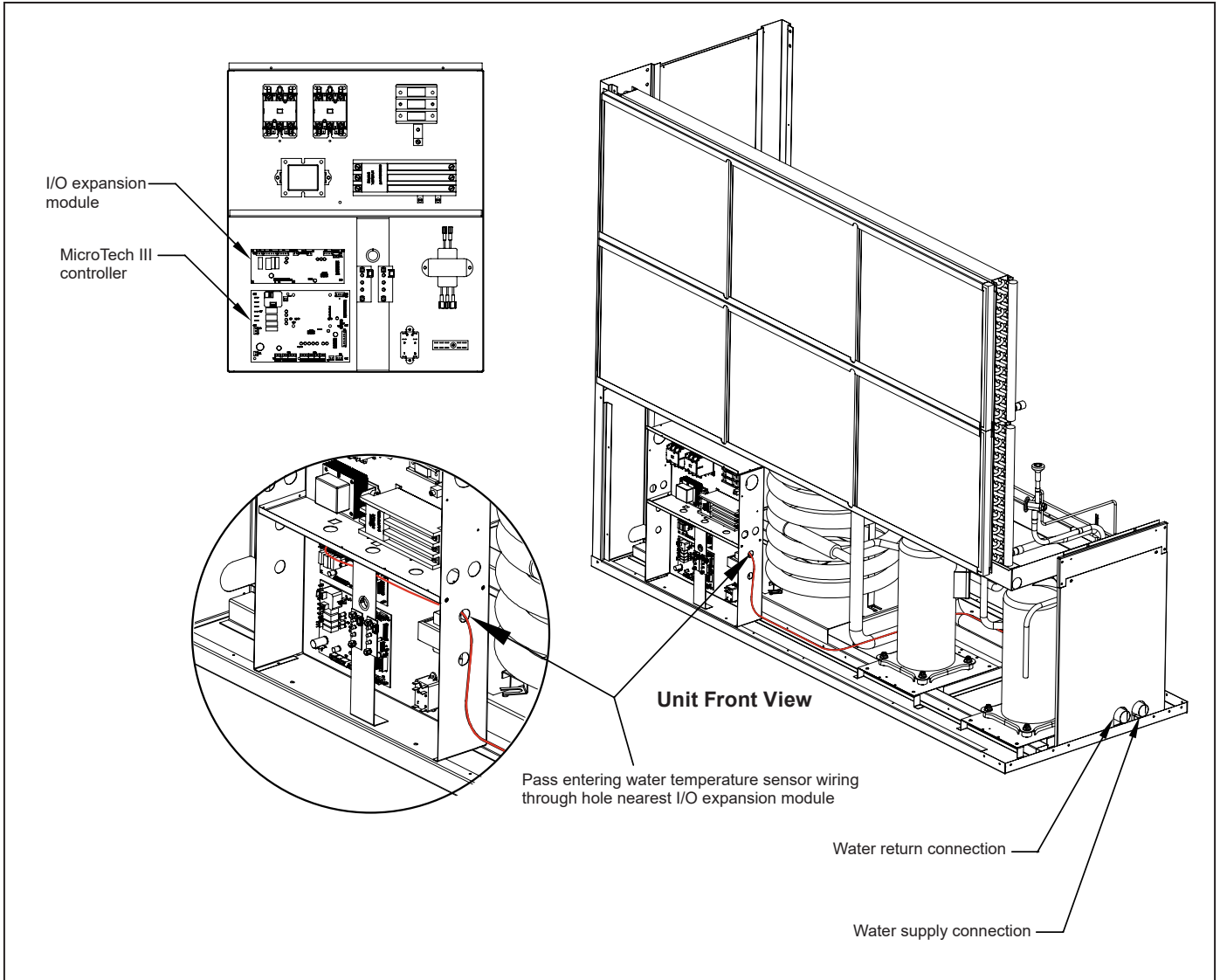

Figure 8: Control box location and sensor location detail for large capacity vertical Infinity unit



SmartSource R32 WSHP units without an I/O expansion module – kit p/n 910448871

This kit includes the parts and quantities as described below. Please make sure all contents are present before beginning the installation procedure.

Description	Quantity
MicroTech 2300 I/O Expansion Module	1
Standoff 7/16	6
Assembly, Harness ELEC HT- H6 to Relay Board Connection	1
Assembly, EWT Sensor to Board Connection	1
Prestite Insulation	1
Clamp	1
Diagram – BSK MT2300	1
Instruction, Component Placement	1
IM 1084	1

R32 WSHP units with an I/O expansion module – kit p/n 910461555

This kit includes the parts and quantities as described below. Please make sure all contents are present before beginning the installation procedure.

Description	Quantity
Assembly, Harness ELEC HT- H6 to Relay Field Connection	1
Assembly, EWT Sensor field connection	1
Prestite Insulation	1
Clamp	1
Diagram - BSK	1
Instruction, Component Placement	1
IM 1084	1

Procedure for SmartSource R32 WSHP units

1. Install the entering water temperature sensor to the supply water pipe with provided clamp as shown in [Figure 9](#). Wrap the entering water temperature sensor with Prestite insulation.

2. Install the I/O expansion module (if provided with kit) to the MT2300 control box using provided stand-offs (see [Figure 11](#) and [Figure 10](#)). Connect MT2310 I/O expansion module harness to header H1, remove the cap from 24VAC wire and connect to wire W120, and connect wire W121 to a ground screw (see [Figure 12](#)).

Note: *The I/O expansion module will be located on the bottom of the control box if the control box is located to the left and mounted to the top if the control box is mounted to the right.*

3. Refer to [Figure 11](#) and connect the I/O expansion module harness between header H3 on the MT2300 controller and header H3 on the MT2310 I/O expansion module.

4. Pass the entering water temperature sensor wire through the control box hole as shown in [Figure 10](#) and connect to terminal H4 on the MT2310 I/O expansion module as shown in [Figure 11](#).

NOTE: *For units with a factory installed MT2310 I/O expansion module, the entering water temperature sensor should be connected to a mating harness that connects to pins 3, and 4 of header H4 on the MT2310 I/O expansion module.*

5. Apply the provided schematic label to the inside of the compressor compartment access panel (or other suitable location) for future reference.

6. Connect the electric heat harness plug, wires #84 and #85 to header H6 on the MT2300 I/O expansion module ([Figure 11](#)). Route the wires out through the low voltage hole on the unit corner post. Connect the wires to the duct heater control per applicable electrical codes.

Note: *The MT2310 I/O expansion module software version and MT2300 controller software version must be compatible. Units not having an MT2310 I/O expansion module may need to have the software version for the MT2300 controller updated to a newer version. For compatibility information contact the controls department in Minneapolis, MN (1-866-462-7829).*

Figure 9: Compressor compartment and sensor placement detail for small horizontal SmartSource Compact unit

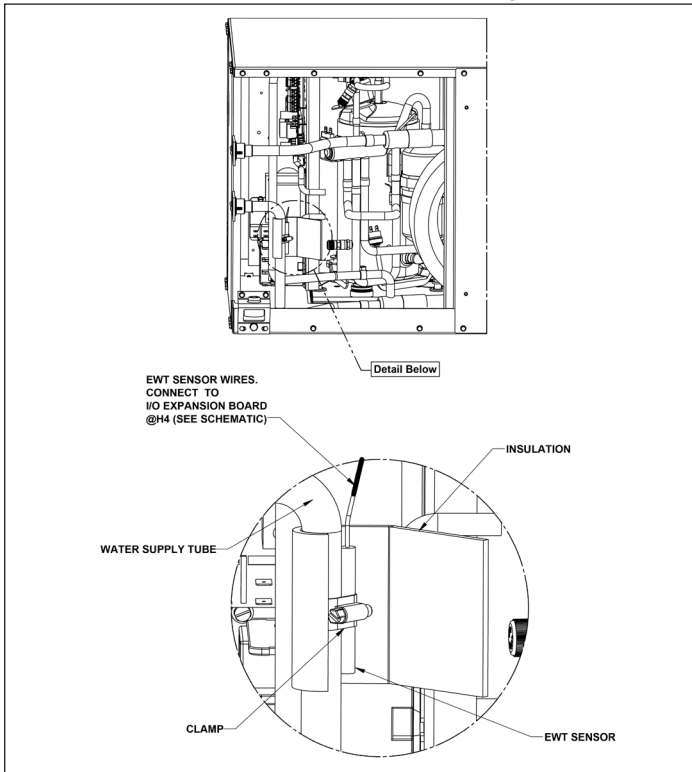

Figure 10: Control box location and sensor location detail for small horizontal SmartSource Compact unit

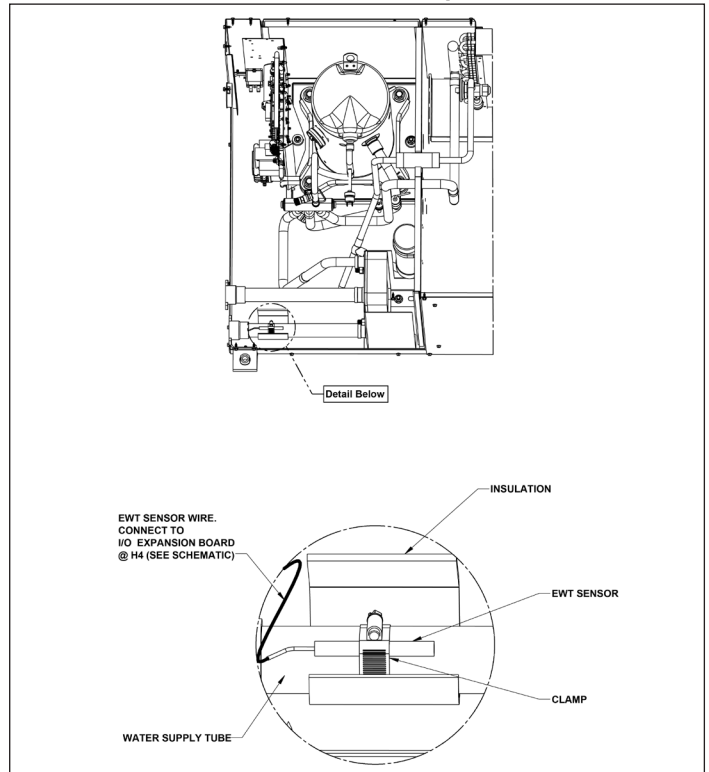

Figure 11: I/O expansion module terminal connection detail for SmartSource Horizontal Unit sizes 007-070

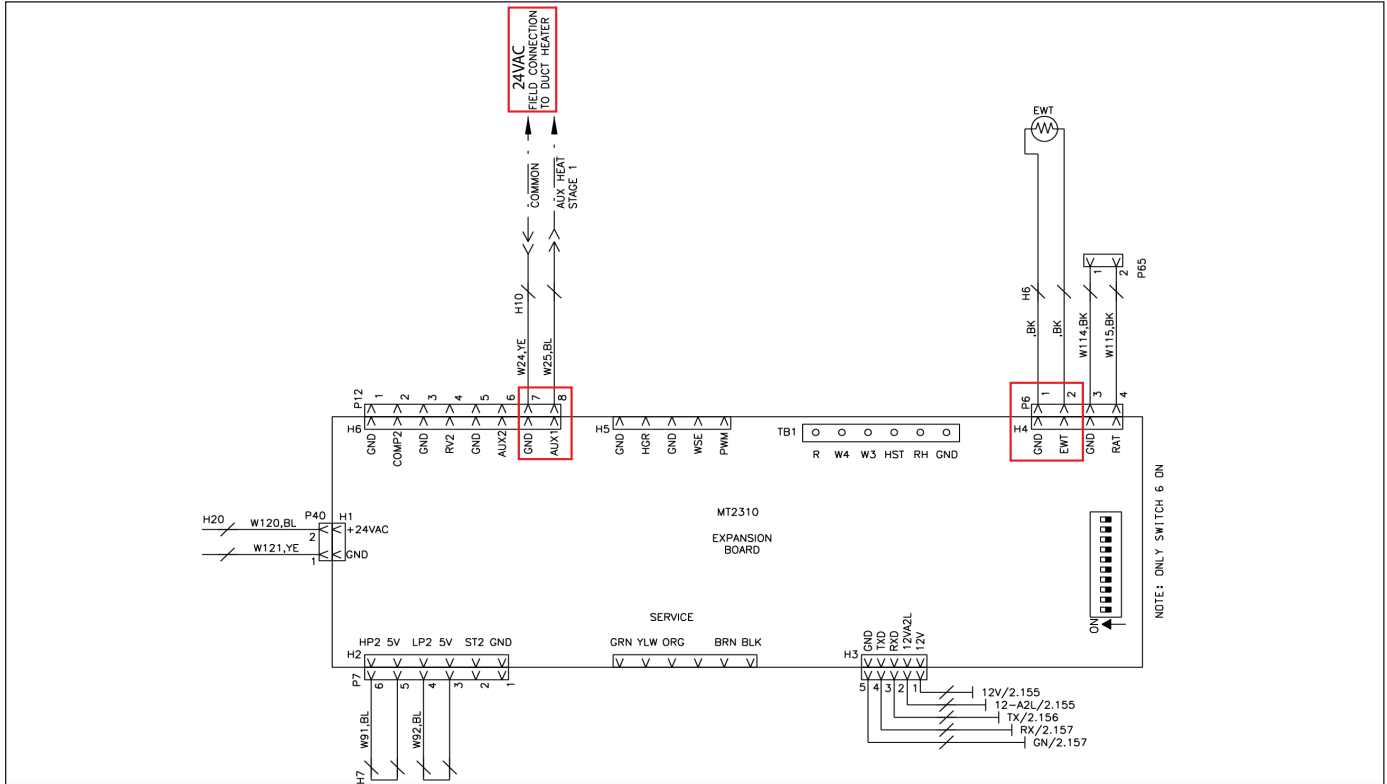
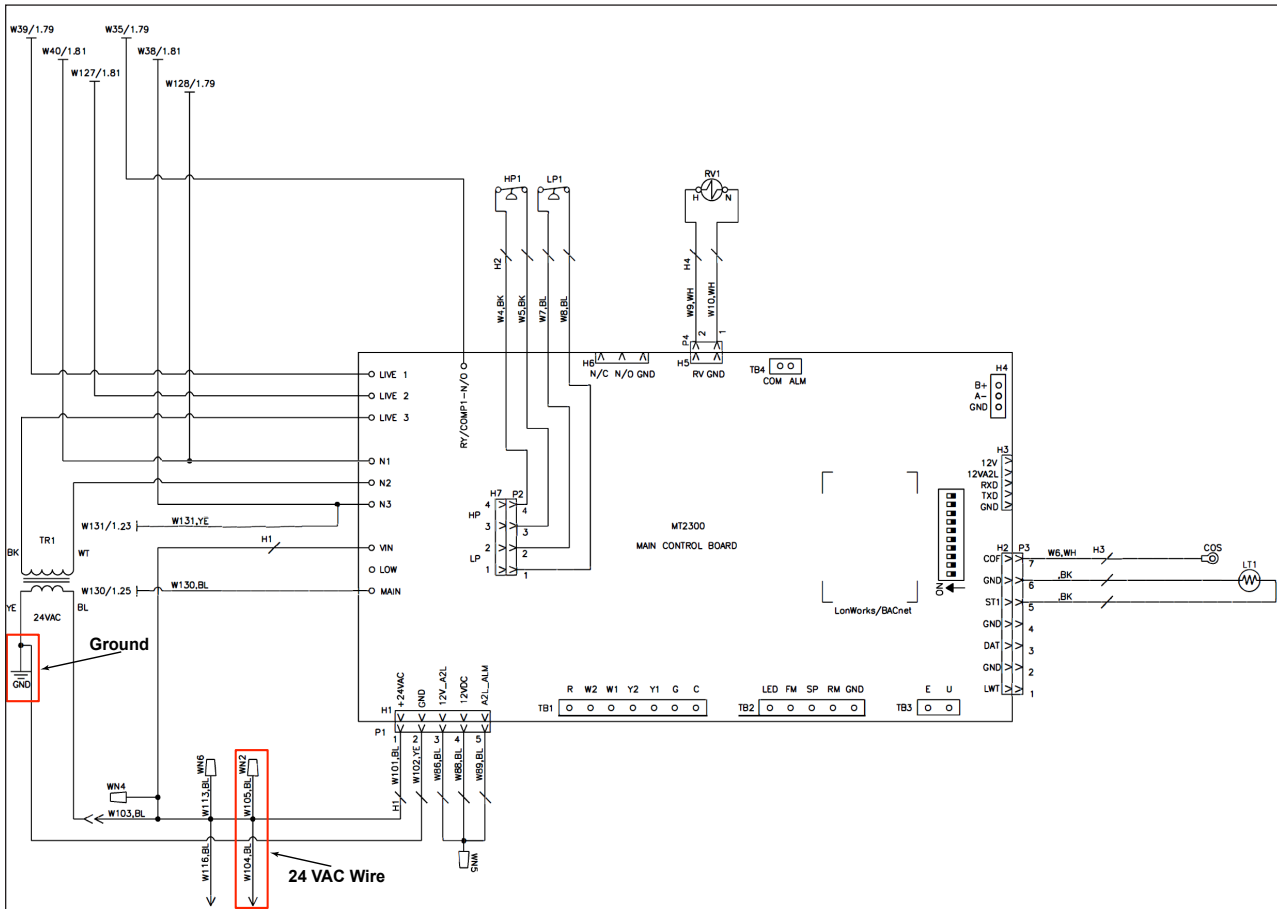

Figure 12: 24VAC Wiring Schematic for Field Installed I/O Expansion Module





Daikin Applied Training and Development

Now that you have made an investment in modern, efficient Daikin Applied equipment, its care should be a high priority. For training information on all Daikin Applied HVAC products, please visit us at www.DaikinApplied.com and click on Training, or call 540-248-9646 and ask for the Training Department.

Warranty

All Daikin Applied equipment is sold pursuant to its standard terms and conditions of sale, including Limited Product Warranty. Consult your local Daikin Applied representative for warranty details. Refer to Form 933-430285Y. To find your local Daikin Applied representative, go to www.DaikinApplied.com.

Aftermarket Services

To find your local parts office, visit www.DaikinApplied.com or call 800-37PARTS (800-377-2787). To find your local service office, visit www.DaikinApplied.com or call 800-432-1342.

This document contains the most current product information as of this printing. For the most up-to-date product information, please go to www.DaikinApplied.com.

Products manufactured in an ISO Certified Facility.