



## Installation and Maintenance Manual

**IM 1139-13**

Group: **WSHP**

Document PN: **IM1139-13**

Date: **May 2024**

## SmartSource® Horizontal Water Source Heat Pump

**Model GSH - Single Stage Horizontal Unit (Sizes 007-070)**

**Model GTH - Two-Stage Horizontal Unit (Sizes 026-072)**

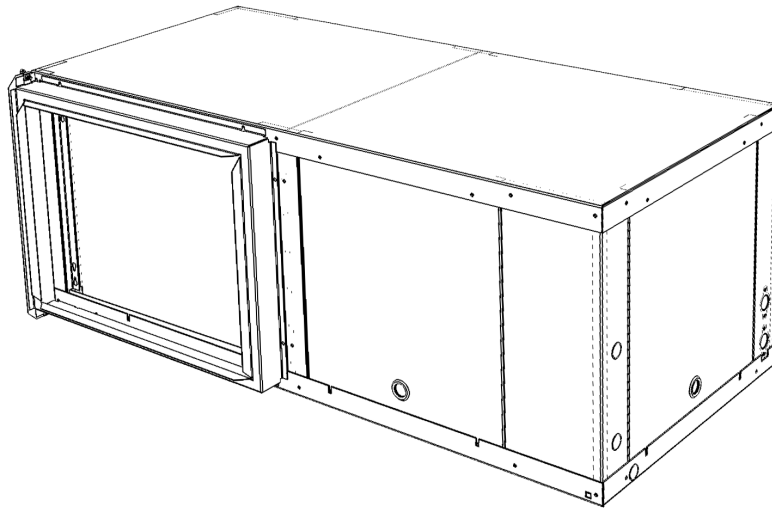

<b>Hazard Identification Information</b> .....	<b>3</b>	<b>Start-up</b> .....	<b>39</b>
<b>Model Nomenclature</b> .....	<b>4</b>	Information for Initial Start-up .....	39
<b>General Information</b> .....	<b>6</b>	Check, Test & Start Procedure .....	39
Safety, Receiving and Storage .....	6	<b>Typical Wiring Diagrams</b> .....	<b>40</b>
Pre-Installation Checklist .....	6	MicroTech III Unit Control with BACnet Communication Module (HGRH) - 265-277V, 1-Phase .....	40
<b>Physical Data</b> .....	<b>7</b>	MicroTech III Unit Control with BACnet Communication Module (WSE & DSH) - 208-230V, 1-Phase with 115V Loop Pumps and 20kW Electric Heat .....	41
<b>System Applications</b> .....	<b>8</b>	MicroTech III Unit Control with LONWORKS Communication Module .....	42
Water Loop Application .....	8	208-230V, 3-Phase with 230V Loop Pumps and 5kW Electric Heat .....	42
Ground-Loop Application .....	8	MicroTech III Unit Control with BACnet Communication Module (WSE) 460V, 3-Phase with 230V Loop Pumps and 20kW Electric Heat .....	43
Ground-Water Application .....	10	MicroTech III Unit Control with Hydronic Heat (HYH) – 208-230V .....	44
Water System Quality .....	12	Motor Removal .....	45
Supply & Return Piping .....	14	Typical Refrigeration Cycles .....	46
Discharge Air Conversion .....	15	<b>Operating Limits</b> .....	<b>47</b>
Hanger Brackets .....	17	Environment .....	47
Ductwork and Attenuation .....	18	Motorized Isolation Valve .....	47
Duct Location Dimensions .....	19	MicroTech III Unit Control with BACnet Communication Module (HGRH)- 265-277V, 1-Phase, Service & Disconnect .....	48
Return Air Filter Rack Assembly & Duct Collar Connections .....	20	MicroTech III Unit Control with BACnet Communication Module (WSE & DSH) Service & Disconnect - 208- 230V, 1-Phase with 115V Loop Pumps and 20kW Electric Heat .....	49
Unit Piping and Electrical Connections Dimensions	20	MicroTech III Unit Control with LONWORKS Communication Module Service & Disconnect 208- 230V, 3-Phase with 230V Loop Pumps and 5kW Electric Heat .....	50
Waterside Economizer Piping Connections .....	21	MicroTech III Unit Control with BACnet Communication Module (WSE) Service & Disconnect - 460V, 3-Phase with 230V Loop Pumps and 20kW Electric Heat. . .	51
<b>Electrical Connections</b> .....	<b>22</b>	<b>Maintenance</b> .....	<b>52</b>
GSH/GTH Unit With Non-Fused Disconnect Switch	23	General Maintenance .....	52
Line Voltage Electrical Connections With Disconnect – 115-460V .....	23	Lubrication .....	52
Low Voltage Wire Connections .....	24	Charging .....	52
Thermostats and Remote Indoor Sensor .....	26	<b>Troubleshooting</b> .....	<b>53</b>
Room Temperature Sensors .....	27		
<b>Piping</b> .....	<b>28</b>		
Condensate Drain Connection .....	28		
Cleaning & Flushing System .....	29		
<b>Controls</b> .....	<b>30</b>		
Jumper Configuration Settings .....	32		
MicroTech® III SmartSource Unit Controller .....	33		
MicroTech SmartSource Controller with LONWORKS® Communication Module .....	34		
MicroTech SmartSource Controller with BACnet® Communication Module .....	34		
Constant Torque EC Motor .....	35		
Constant CFM Type EC Motor Fan Settings .....	36		
Fan Performance For Constant CFM EC Motor (Sizes 015–072) .....	37		
Fan Speed Selector Switch .....	38		
Fan CFM Settings & Performance .....	38		

## Hazard Identification Information

### **WARNING**

This Installation and Maintenance bulletin is intended to provide the proper procedures for installing a Daikin Water Source Heat Pump. Failure to follow these procedures can cause property damage, severe personal injury or death. Additional, failure to follow these procedures can cause premature failure of this equipment or cause erratic unit operation, resulting in diminished unit performance. Disregarding these directions may further lead to suspension or revocation of the manufacturer's warranty.

### **DANGER**

Dangers indicate a hazardous situation, which will result in death or serious injury if not avoided.

### **WARNING**

Warnings indicate potentially hazardous situations, which can result in property damage, severe personal injury, or death if not avoided.

### **CAUTION**

Cautions indicate potentially hazardous situations, which can result in personal injury or equipment damage if not avoided.

**Note:** *Indicates important details or clarifying statements for information presented.*

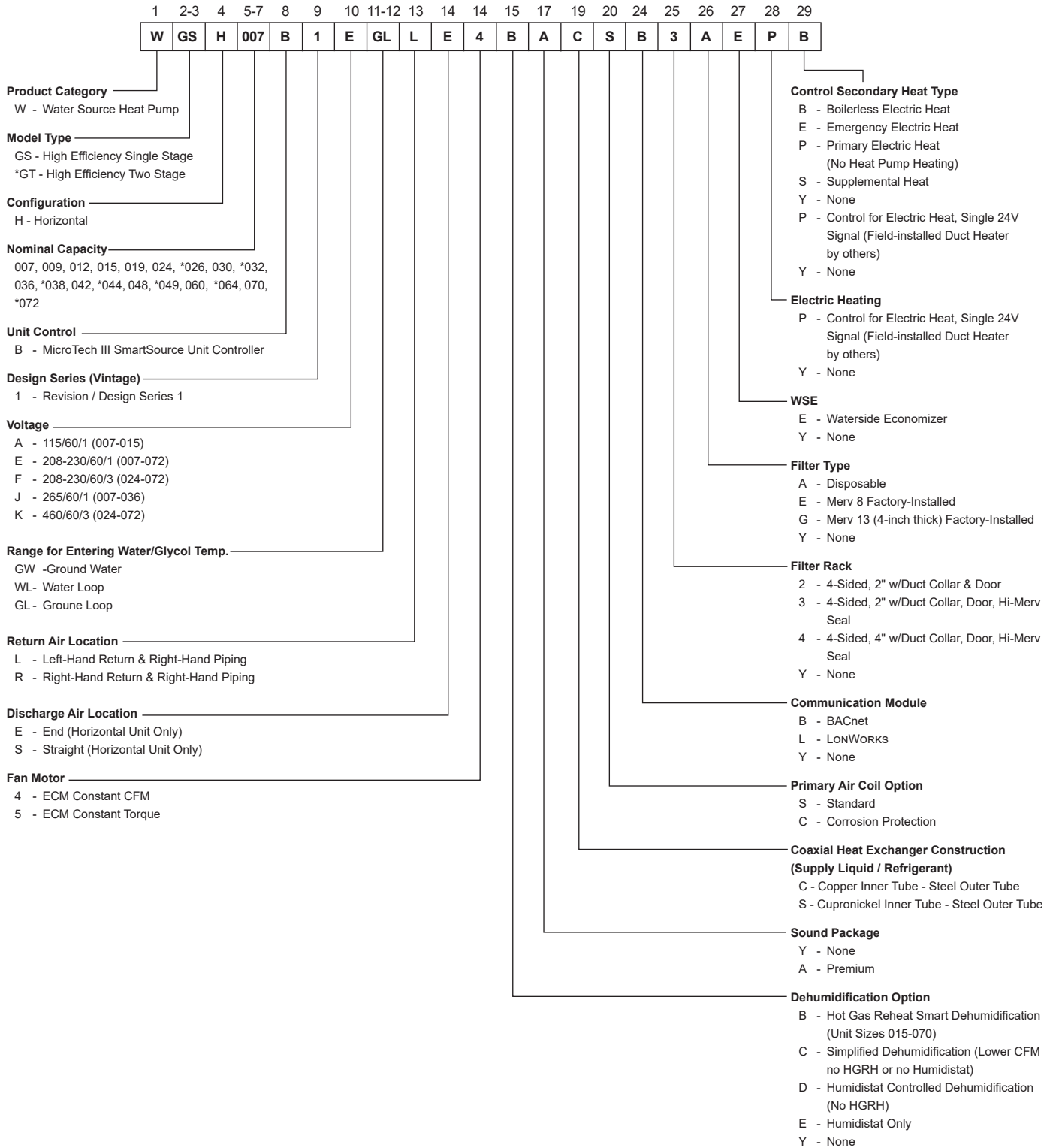



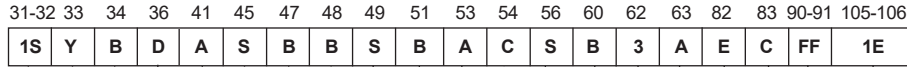

**Loop Pump**

- 1S - One Low Head Pump
- 1L - One High Head Pump
- 2S - Two Low Head Pumps
- 2L - Two High Head Pumps
- YY - None

**Coaxial Coil Supply**

**Liquid Flow Control**

- B - 2-Way, Motorized - 24v Valve Control, NO
- Y - None

**Coaxial Coil Supply**

**Liquid Auto Flow Reg**

- A - Auto Flow Control 1.5 GPM
- B - Auto Flow Control 2.0 GPM
- C - Auto Flow Control 2.5 GPM
- D - Auto Flow Control 3.0GPM
- E - Auto Flow Control 4.0 GPM
- G - Auto Flow Control 5.0 GPM
- H - Auto Flow Control 6.0 GPM
- I - Auto Flow Control 8.0 GPM
- J - Auto Flow Control 9.0 GPM
- K - Auto Flow Control 10.0 GPM
- L - Auto Flow Control 11.0 GPM
- M - Auto Flow Control 12.0 GPM
- N - Auto Flow Control 13.0 GPM
- P - Auto Flow Control 15.0 GPM
- S - Auto Flow Control 18.0 GPM
- Y - None

**Pressure Differential Switch**

- D - Pressure Differential Switch
- Y - None

**Water Coil Piping Package Options**

**(Hot Water or Waterside Economizer)**

- A - 3-Way Motorized - 24V Valve Control, NO to Coax

**Primary Drain Pan Material**

- S - Stainless Steel

**Compressor Insulation**

- B - Compressor Insulation Sound Blanket (024-072)
- Y - None

**Compressor Isolation**

- B - Isolated base

**Unit Cabinet Insulation**

- S - 1/2" Fiberglass Skin-Face in Compressor Section, 1/2" Fiberglass Foil-Face Insulation in Airside Section
- I - Indoor Air Quality Insulation Package - 3/8" Closed Cell Foam in Compressor Section, 3/8" Closed Cell Foam Insulation in Airside Section
- R - Sound Reduction Package - 3/4" Sound Insulation in Compressor Section and Air Section (Unit Sizes 007 - 019)\*  
1/2" Fiberglass Skin-Face in Compressor Section with Compressor Sound Blanket, 3/4" Sound Insulation in Airside Section (Unit Sizes 024 - 072)

**Extended Warranty, Parts Only**

- YY - None
- 1E - 1-Year, Entire Unit Parts Only
- 2C - 2-Year Parts (Compressor Only)
- 2R - 2-Year Parts (Refrigerant Circuit)
- 3C - 3-Year Parts (Compressor Only)
- 3R - 3-Year Parts (Refrigerant Circuit)
- 4C - 4-Year Parts (Compressor Only)
- 4R - 4-Year Parts (Refrigerant Circuit)

**Freeze Fault**

- FF - Freeze Fault Protection
- YY - None

**Alarm Relay**

- A - Alarm Relay (Dry Contacts)
- Y - None

**Expansion Device**

- A - Thermal Expansion Valve Thermal Bulb and Equalizer Tube

**Thermostat/Sensor Control**

- T - Thermostat Control
- S - Sensor Control

**Control Transformer**

- 1 - 50VA Control Transformer
- 2 - 75VA Control Transformer

**Disconnect Switch**

- Y - None
- N - Non-Fused

**Fan Motor Control**

- C - Various Speeds with 4 Adjustment Settings

**Cabinet Color**

- Y - None
- W - Off White
- T - Textured Charcoal Bronze

**Cabinet Finish**

- A - Powder Coat
- Y - None

**Insulation - Piping**

- A - Insulated Piping
- Y - None

## Safety, Receiving and Storage

### CAUTION

Sharp edges can cause personal injury. Avoid contact with them.

Upon receipt of the equipment, check carton for visible damage. Make a notation on the shipper's delivery ticket before signing. If there is any evidence of rough handling, immediately open the cartons to check for concealed damage. If any damage is found, notify the carrier within 48 hours to establish your claim and request their inspection and a report. The Warranty Claims Department should then be contacted.

For storing, each carton is marked with "up" arrows.

The unit should be shipped or stored in the normal upright position. Do not operate the machine until it has been in the normal upright position for at least 24 hours.

Temporary storage at the job site must be indoor, completely sheltered from rain, snow, etc. Units should not be installed in environments that fall below freezing or exceed 140°F ambient.

### IMPORTANT

This product was carefully packed and thoroughly inspected before leaving the factory. Responsibility for its safe delivery was assumed by the carrier upon acceptance of the shipment. Claims for loss or damage sustained in transit must therefore be made upon the carrier as follows:

#### VISIBLE LOSS OR DAMAGE

Any external evidence of loss or damage must be noted on the freight bill or carrier's receipt, and signed by the carrier's agent. Failure to adequately describe such external evidence of loss or damage may result in the carrier's refusal to honor a damage claim. The form required to file such a claim will be supplied by the carrier.

#### CONCEALED LOSS OR DAMAGE

Concealed loss or damage means loss or damage which does not become apparent until the product has been unpacked. The contents may be damaged in transit due to rough handling even though the carton may not show external damages. When the damage is discovered upon unpacking, make a written request for inspection by the carrier's agent within fifteen (15) days of the delivery date and file a claim with the carrier.

### WARNING

The installer must determine and follow all applicable local and national codes and regulations. This equipment presents hazards of electricity, rotating parts, sharp edges, heat and weight. Failure to read and follow these instructions can result in property damage, severe personal injury or death. This equipment must be installed by experienced, trained personnel only.

## Pre-Installation Checklist

### Check all that apply:

- To prevent damage, do not operate this equipment for supplementary ventilation, heating and cooling during the construction period.
- Inspect the carton for any specific tagging numbers indicated by the factory per a request from the installing contractor.
- Check the unit data plate for correct voltage, phase and capacity with the plans before installing the equipment. Also, make sure all electrical ground connections are made in accordance with local code.

**Table 1: Operating Voltages**

Voltage	Minimum	Maximum
115/60/1	103	126
208-230/60/1	197	253
265/60/1	238	292
208-230/60/3	197	253
460/60/3	414	506

**Note:** Three-phase system imbalance shall not exceed 2%.

- If 460/60/3 unit includes a constant CFM EC motor verify that a 4-wire power supply is provided that includes a neutral wire providing 265 volt power to the fan motor.
- Check the unit size against the plans to verify that the unit is being installed in the correct location.
- Before installation, check the available ceiling height versus the height of the unit.
- Note the location and routing of water piping, condensate drain piping, and electrical wiring. The locations of these items are clearly marked on submittal drawings.
- The installing contractor will find it beneficial to confer with piping, sheet metal, and electrical foremen before installing any unit.
- The contractor shall cover the units to protect the machines during building construction. This is critical while spraying fireproofing material on bar joists, sandblasting, spray painting and plastering. If plastic film is not available, the shipping carton may be modified to cover the units during construction.
- Remove shipping brackets securing unit to skid.

**Table 2: Unit sizes 007 through 032**

Description	Unit Sizes 007 through 032						
	007	009	012	015	019	024/026	030/032
Compressor Type	Rotary	Rotary	Rotary	Rotary	Rotary	Scroll	Scroll
Refrigeration Charge (Oz.)	26	26	29	42	42	56	54
Fan Wheel (D x W)	6" x 8"	6" x 8"	6" x 8"	9" x 7"	9" x 7"	9" x 7"	9" x 7"
Fan Motor HP	1/10	1/10	1/10	1/3	1/3	1/3	1/2
Water Connection Size (FPT)	1/2"	1/2"	1/2"	3/4"	3/4"	3/4"	3/4"
Coax & Water Piping Volume (Gal. @ 70°F)	0.2	0.2	0.2	0.5	0.5	0.5	0.5
Condensate Connection Size (FPT)	3/4	3/4	3/4	3/4	3/4	3/4	3/4
Air Coil Face Area (Sq Ft.)	2.1	2.1	2.1	2.5	2.5	4.1	4.1
Waterside Economizer Coil Volume (Gal.)	0.64		0.85			1.28	
Nominal Filter Size	15" x 21"			18" x 24"		17" x 34"	
Operating Weight	148	151	154	200	214	254	256
Shipping Weight	165	168	171	214	228	289	291

**Table 3: Unit sizes 036 through 072**

Description	Unit Sizes 036 through 072				
	036/038	042/044	048/049	060/064	070/072
Compressor Type	Scroll	Scroll	Scroll	Scroll	Scroll
Refrigeration Charge (Oz.)	72	90	88	120	122
Fan Wheel (D x W)	11" x 10"	11" x 10"	11" x 10"	11" x 10"	11" x 10"
Fan Motor HP	1/2	3/4	3/4	1	1
Water Connection Size (FPT)	3/4"	1"	1"	1"	1"
Coax & Water Piping Volume (Gal. @ 70°F)	1.1	1.2	1.2	2.1	2.1
Condensate Connection Size (FPT)	3/4	3/4	3/4	3/4	3/4
Air Coil Face Area (Sq Ft.)	5.0	5.6	5.6	6.4	6.4
Waterside Economizer Coil Volume (Gal.)	1.59		1.84		2.09
Nominal Filter Size	19" x 37"	19" x 43"		19" x 48"	
Operating Weight	329	365	367	472	478
Shipping Weight	361	408	410	514	521

**Table 4: Horizontal unit corner weights, percentage of total operating weight (Base unit only)**

Unit Size	Total Operating Weight (lbs.)	Corner Weight % of Total Operating Weight			
		A	B	C	D
007	148	30%	20%	20%	30%
009	151				
012	154				
015	200				
019	214				
024/026	254				
030/032	256				
036/038	329				
042/044	365				
048/049	367				
060	472				
070/072	478				

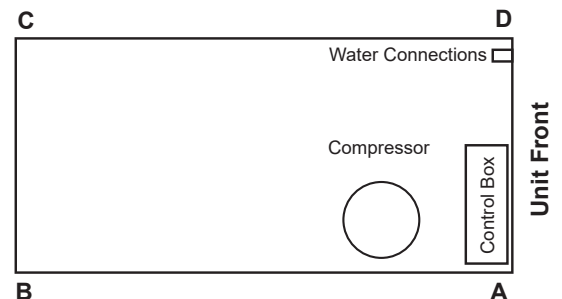

## Water Loop Application

Commercial systems typically include a number of units connected to a common piping system. Any unit plumbing maintenance work can introduce air into the piping system; therefore air elimination equipment is a major portion of the mechanical room plumbing. In piping systems expected to utilize water temperatures below 50°F [10°C], closed cell insulation is recommended on all piping surfaces to eliminate condensation (extended range units required). Metal to plastic threaded joints should never be used due to their tendency to leak over time. All SmartSource units include flush mounted FPT water connections integral to the unit corner post, which do not require a backup wrench.

A thread sealant is recommended to minimize internal fouling of the heat exchanger. Do not over tighten connections and route piping so as not to interfere with service or maintenance access. Hose kits are available from Daikin in different configurations for connection between the unit and the piping system. Depending upon selection, hose kits may include shut off valves, P/T plugs for performance measurement, high pressure stainless steel braided hose, “Y” type strainer with blow down valve, and/or “J” type swivel connection. Balancing valves and an external low pressure drop solenoid valve for use in variable speed pumping systems may also be included in the hose kit.

The piping system should be flushed to remove dirt, piping chips, and other foreign material prior to operation (see "Cleaning & Flushing System" on page 29). The water flow rates should be kept at approximately 3 GPM per nominal cooling ton (a 10°F temperature rise in cooling). To ensure proper maintenance and servicing, P/T ports are imperative for temperature and flow verification, as well as performance checks.

Water loop heat pump (cooling tower/boiler) systems typically utilize a common loop, maintained between 60 - 90°F [16 - 32°C]. The use of a closed circuit evaporative cooling tower with a secondary heat exchanger between the tower and the water loop is recommended. If an open type cooling tower is used continuously, chemical treatment and filtering may be necessary.

## Ground-Loop Application

### CAUTION

The following instructions represent industry accepted installation practices for closed loop earth coupled heat pump systems. Instructions are provided to assist the contractor in installing trouble free ground loops. These instructions are recommendations only. State/provincial and local codes **MUST** be followed and installation **MUST** conform to ALL applicable codes. It is the responsibility of the installing contractor to determine and comply with ALL applicable codes and regulations.

### CAUTION

Ground loop applications require extended range equipment and optional refrigerant/water circuit insulation.

## Pre-Installation

Prior to installation, locate and mark all existing underground utilities, piping, etc. Install loops for new construction before sidewalks, patios, driveways, and other construction has begun. During construction, accurately mark all ground loop piping on the plot plan as an aid in avoiding potential future damage to the installation.

## Piping Installation

The typical closed loop ground source system is shown in [Figure 2 on page 9](#). All earth loop piping materials should be limited to polyethylene or equivalent per International Ground Source Heat Pump Association (IGSHPA)

**Figure 1: Polyethylene fused piping**

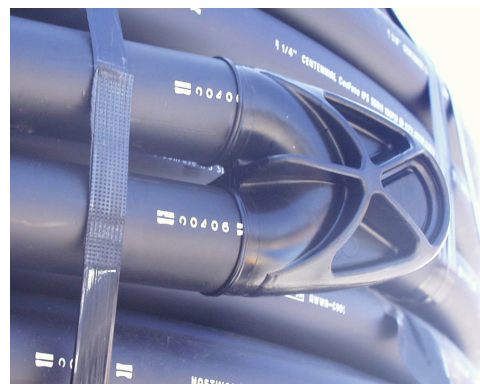

Galvanized or steel fittings should not be used at any time due to their tendency to corrode. All plastic to metal threaded fittings should be avoided due to their potential to leak in earth coupled applications. A flanged fitting should be substituted. P/T plugs should be used so that flow can be measured using the pressure drop of the unit heat exchanger.

**Figure 2: Typical water loop application (with optional unit-mounted loop pumps)**

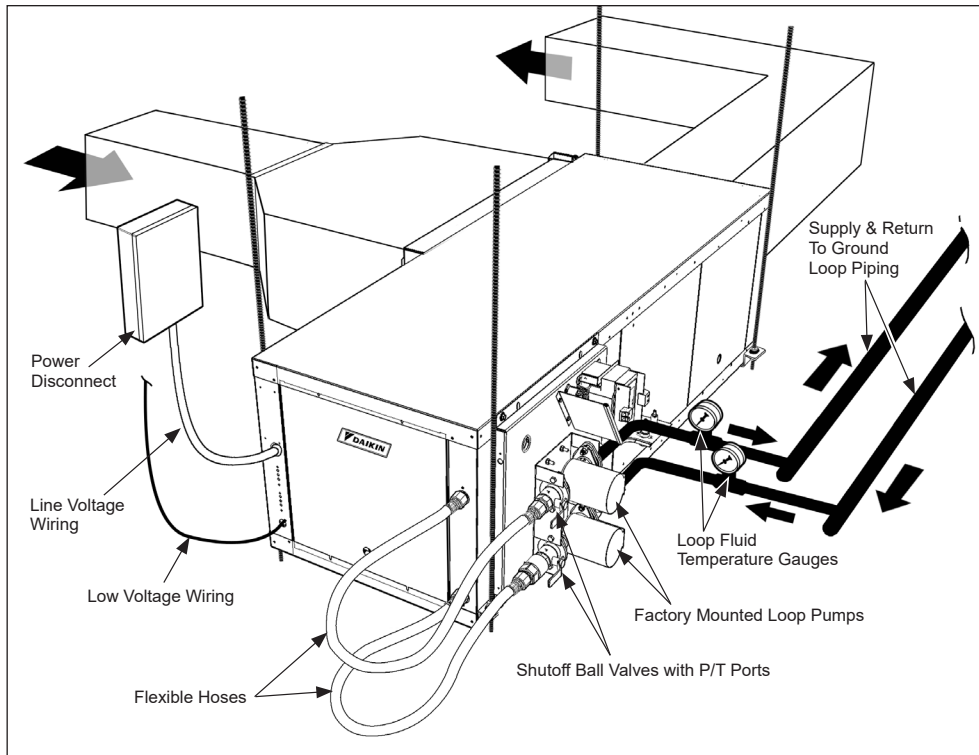

Earth loop temperatures can range between 25 and 110°F [-4 to 43°C]. The water flow rates should be kept at approximately 3 GPM per nominal cooling ton (a 10°F temperature rise in cooling).

Test individual horizontal loop circuits before backfilling. Test vertical U-bends and pond loop assemblies prior to installation. Pressures of at least 100 psi [689 kPa] should be used when testing. Do not exceed the pipe pressure rating. Test entire system when all loops are assembled.

**Flushing the Earth Loop**

Upon completion of system installation and testing, flush the system to remove all foreign objects and purge to remove all air.

**Antifreeze**

In areas where minimum entering loop temperatures drop below 50°F [10°C] or where piping will be routed through areas subject to freezing, antifreeze is required. Alcohols and glycols are commonly used as antifreeze; however your local sales office should be consulted to determine the antifreeze best suited to your area. Freeze protection should be maintained to 15°F [9°C] below the lowest expected entering loop temperature. For example, if 30°F [-1°C] is the minimum expected entering loop temperature, the leaving loop temperature would be 22 to 25°F [-6 to -4°C] and freeze protection should be at 15°F [-10°C]. Calculation is as follows: 30°F - 15°F = 15°F [-1°C - 9°C = -10°C].

All alcohols should be premixed and pumped from a reservoir outside of the building when possible or introduced under the water level to prevent fumes.

Calculate the total volume of fluid in the piping system. Then use the percentage by volume shown in [Table 6 on page 10](#) for the amount of antifreeze needed. Antifreeze concentration should be checked from a well mixed sample using a hydrometer to measure specific gravity.

**Figure 3: Flushing the loop**

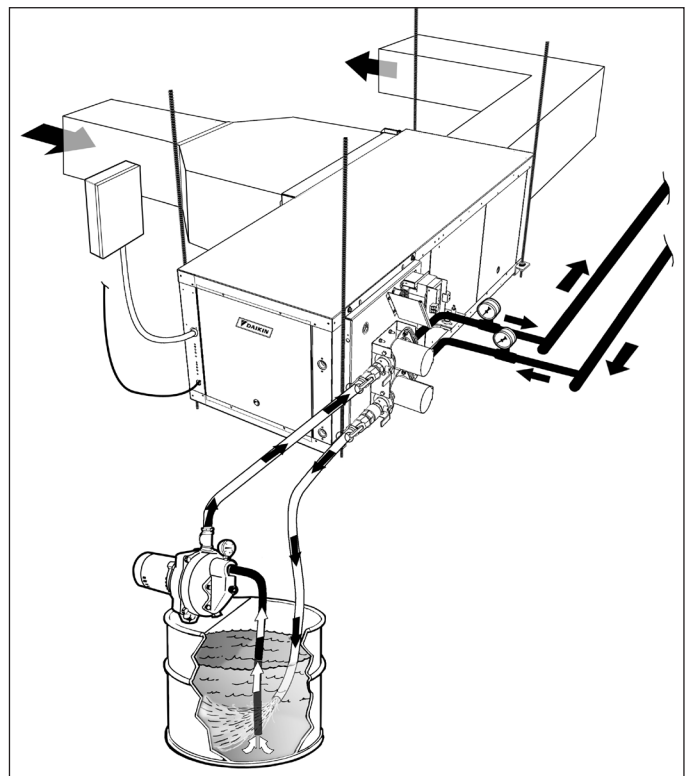

**Table 5: Antifreeze percentage by volume**

Type	Minimum Temperature for Low Temperature Protection			
	10°F [-12.2°C]	15°F [-9.4°C]	20°F [-6.7°C]	25°F [-3.9°C]
Methanol	25%	21%	16%	10%
100% USP food grade Propylene Glycol	38%	25%	22%	15%
Ethanol <sup>1</sup>	29%	25%	20%	14%

Note: <sup>1</sup> Must not be denatured with any petroleum product.

**Table 6: Antifreeze correction factors (for heat pump operation only)**

	Antifreeze % By Weight			
	15%	25%	35%	45%
<b>Ethanol</b>				
Cooling Capacity	0.985	–	–	–
Heating Capacity	0.9825	–	–	–
Pressure Drop	1.04	–	–	–
<b>Ethylene Glycol</b>				
Cooling Capacity	0.9935	0.9895	0.985	0.981
Heating Capacity	0.9865	0.9795	0.973	0.965
Pressure Drop	1.10	1.16	1.22	1.27
<b>Methanol</b>				
Cooling Capacity	0.985	–	–	–
Heating Capacity	0.9825	–	–	–
Pressure Drop	1.04	–	–	–
<b>Propylene Glycol</b>				
Cooling Capacity	0.985	0.975	0.965	0.955
Heating Capacity	0.981	0.9685	0.952	0.936
Pressure Drop	1.11	1.20	1.31	1.40

## Ground-Water Application

**Open Loop - Ground Water Systems** - Typical open loop piping is shown in [Figure 4](#). Shut off valves should be included for ease of servicing. Boiler drains or other valves should be installed in the supply and return lines to allow cleaning of the heat exchanger. Shut off valves should be positioned to allow flow through the coax via the boiler drains without allowing flow into the piping system. P/T plugs should be used so that pressure drop and temperature can be measured. Piping materials should be limited to copper.

### **WARNING**

PVC or CPVC should not be used as they are not compatible with the POE oils used in HFC-410A products and piping system failure and property damage may result.

Water quantity should be plentiful and of good quality. See "Water impurities, result & recommended water system application" on [page 13](#) for water quality guidelines. The unit can be ordered with either a copper or cupro-nickel water heat exchanger. Consult [Table 8 on page 13](#) for recommendations. Copper is recommended for open loop ground water systems that are not high in mineral content or corrosiveness. In conditions anticipating heavy scale formation or in brackish water, a cupro-nickel heat exchanger is recommended. In ground water situations where scaling could be heavy or where biological growth such as iron bacteria will be present, an open loop system is not recommended. Heat exchanger coils may over time lose heat exchange capabilities due to build up of mineral deposits. Heat exchangers must only be serviced by a qualified technician, as acid cleaning and special pumping equipment may be required.



Figure 4: Typical open loop application

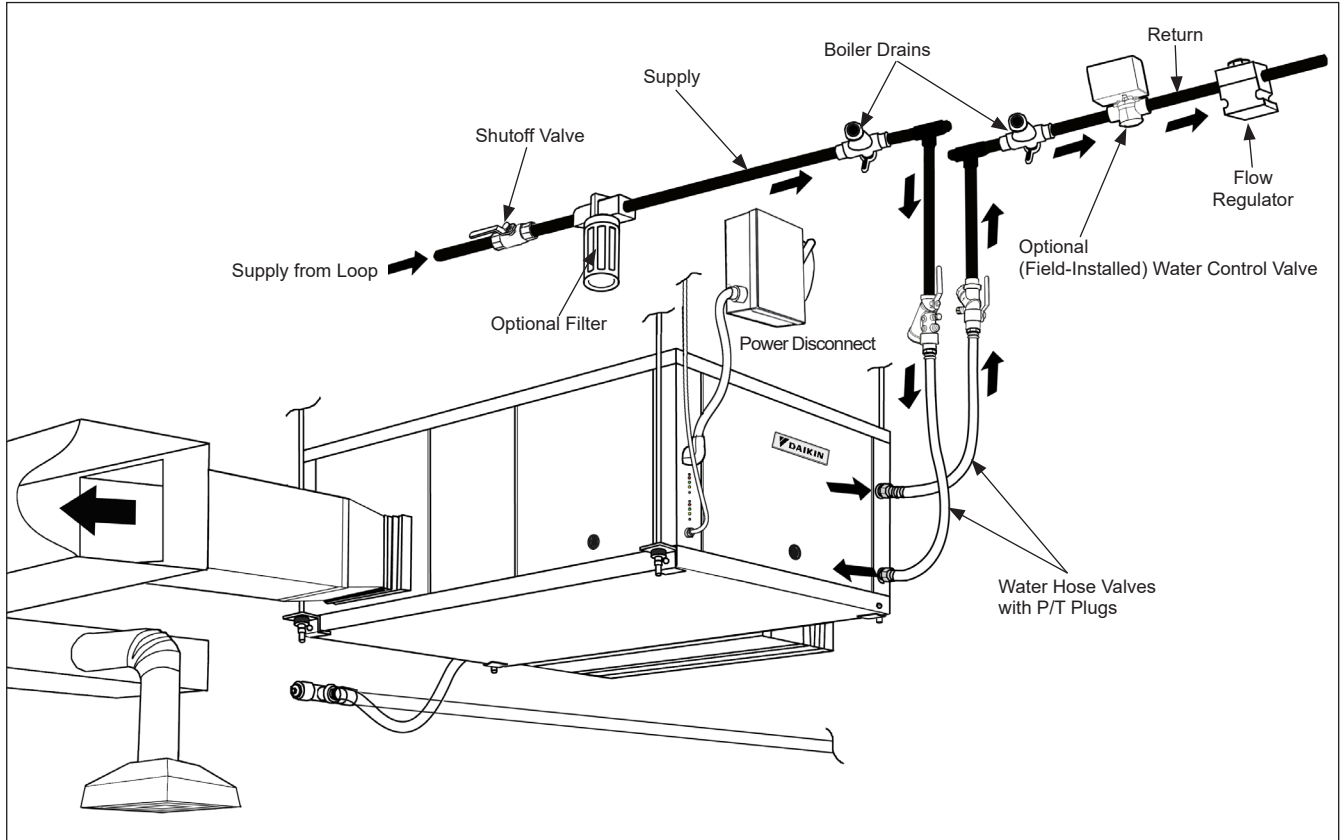

**Water Quality Standards - Table 8**, Water impurities, result & recommended water system application" on page 13 should be consulted for water quality requirements. Scaling potential should be assessed using the pH/Calcium hardness method. If the pH <7.5 and the calcium hardness is less than 100 ppm, scaling potential is low. If this method yields numbers out of range of those listed, the Ryznar Stability and Langelier Saturation indices should be calculated. Use the appropriate scaling surface temperature for the application, 150°F [66°C] for direct use (well water/ open loop); 90°F [32°F] for indirect use. A monitoring plan should be implemented in these probable scaling situations. Other water quality issues such as iron fouling, corrosion prevention and erosion and clogging should be referenced in Table 8 on page 13.

**Expansion Tank and Pump** - Use a closed, bladder type expansion tank to minimize mineral formation due to air exposure. The expansion tank should be sized to provide at least one minute continuous run time of the pump using its draw-down capacity rating to prevent pump short cycling. Discharge water from the unit is not contaminated in any manner and can be disposed of in various ways, depending on local building codes (e.g. recharge well, storm sewer, drain field, adjacent stream or pond, etc.). Most local codes forbid the use of sanitary sewer for disposal. Consult your local building and zoning department to assure compliance in your area.

**Water Control Valve** - Note the placement of the water control valve in Figure 4. Always maintain water pressure in the heat exchanger by placing the water control valve(s) on the return line to prevent mineral precipitation during the off-cycle. Pilot operated slow closing valves are recommended to reduce water hammer. If water hammer persists, a mini-expansion tank can be mounted on the piping to help absorb the excess hammer shock. If a field provided motorized valve and actuator is utilized, ensure that the total 'VA' draw of the valve can be supplied by the unit transformer. For instance, a slow closing valve can draw up to 35VA. Units are furnished with a factory-installed 50 VA transformer. An optional 75VA transformer is also available. A typical pilot operated solenoid valve draws approximately 15VA (see Figure 43 on page 47).

**Flow Control** - Flow control can be accomplished by two methods. One method involves simply adjusting the field-provided ball valve or flow control valve on the return line. Measure the pressure drop through the unit heat exchanger, and determine flow rate from [Table 7](#). Since the pressure is constantly varying, two pressure gauges may be needed. Adjust the valve until the desired flow of 1.5 to 4 gpm, per ton [5.7 to 15.1 l/m, per kW] is achieved. A second method of flow control requires a flow control device mounted on the outlet of the flow control valve. This device is typically a brass fitting with an orifice of rubber or plastic material that is designed to allow a specified flow rate. On occasion, flow control devices may produce velocity noise that can be reduced by applying some back pressure from the ball valve located on the discharge line. Slightly closing the valve will spread the pressure drop over both devices, reducing the velocity noise.

**Table 7: Water pressure drop**

Unit Size	GPM	Pressure Drop, psi (kPa)		
		50°F	70°F	90°F
007	1.0	0.7	1.6	0.7
	1.5	1.4	3.0	1.3
	2.0	2.2	4.8	2.0
009	1.9	2.0	1.9	1.8
	2.3	2.7	2.6	2.5
	3.4	3.4	3.3	3.2
012	2.0	5.1	2.1	2.0
	3.0	9.7	4.1	3.9
	4.0	15.4	6.4	6.2
015	2.5	1.2	1.1	1.1
	3.8	2.6	2.5	2.4
	5.0	4.5	4.3	4.2
019	3.8	2.5	2.4	2.3
	4.5	3.6	3.4	3.3
	5.3	4.9	4.7	4.5
024/026	4.0	1.1	1.0	1.0
	6.0	2.3	2.2	2.1
	8.0	3.9	3.7	3.6
030/032	5.0	1.6	1.6	1.5
	7.5	3.4	3.3	3.2
	10.0	5.8	5.5	5.3
036/038	6.0	1.9	1.8	1.8
	9.0	4.0	3.9	3.7
	12.0	6.8	6.5	6.3
042/044	7.0	1.0	1.0	0.9
	10.5	2.1	2.1	2.0
	14.0	3.7	3.5	3.4
048/049	10.0	2.0	1.9	1.8
	12.0	2.8	2.6	2.5
	14.0	3.7	3.5	3.4

060/064	10.0	2.0	2.0	1.9
	15.0	4.4	4.2	4.1
	20.0	7.7	7.3	7.1
070/072	15.0	4.4	4.2	4.1
	18.0	6.3	6.0	5.8
	21.0	8.4	8.1	7.8

## Water System Quality

The cleaning, flushing and chemical treatment of a water source heat pump system is fundamental to efficient operation and the life expectancy of the system.

Potential system problems produced by the use of water fall into three general categories:

- Scale formation** – Mineral deposits which result from the crystallization and precipitation of dissolved salts in the water. The deposits form an insulating barrier, reducing the heat transfer rate and impeding the circulation of fluids due to increased pressure drop.
- Corrosion** – Decomposition of the metal caused by absorption of gases from the air. Corrosion may occur in any metal component of the system.
- Organic growths** – Slime and algae which form under certain environmental conditions, and can reduce the heat transfer rate by forming an insulating coating or can promote corrosion by pitting.

The system water should be evaluated for degrees of impurity, with testing available from independent testing labs, health departments or state agencies.

[Table 8 on page 13](#) is a list of water characteristics, the potential impurities and their results and the recommended treatment.

## Avoiding Potential Problems

As shown in [Table 8 on page 13](#), all water contains some degree of impurities which may affect the performance of a heat pump system. The use of a cupro-nickel coil can help avoid potential problems. Water flow rates should:

- Be high enough that the temperature rise through the heat exchanger does not exceed 12° F when operating in the cooling mode.
- Not exceed 4 GPM per nominal ton. Flow rates that have velocities of 10 feet per second or more may cause pipe erosion and heat exchanger failure.



**Table 8: Water impurities, result & recommended water system application**

Impurity	Copper Coils	Cupro-nickel Coils	Result	Application	
				Open Recirculating	Closed Recirculating
<b>Calcium &amp; Magnesium Salts (hardness)</b>	Less than 350 ppm	350 ppm Sea Water	Scaling	1. Bleed-off 2. Surface active agents such as polyphosphates. 3. Addition of acid. 4. pH adjustment. <i>Other considerations:</i> <ul style="list-style-type: none"> <li>▪ Adequate fouling factor</li> <li>▪ Surface temperature</li> <li>▪ Water temperature</li> <li>▪ Clean system</li> </ul>	No treatment required
<b>Iron oxide</b>	Low levels only	Moderate levels	Corrosion	1. Corrosion inhibitors in high concentrations (200 to 500 ppm). 2. Corrosion inhibitors in low concentrations (20 to 80 ppm). 3. pH control. 4. Proper materials of construction.	Corrosion inhibitors in high concentrations. Proper materials of construction.
<b>pH</b>	7 - 9	5 - 10			
<b>Hydrogen Sulfide</b>	Less than 10 ppm	10 - 50 ppm			
<b>CO<sub>2</sub></b>	Less than 50 ppm	50 - 75 ppm			
<b>Chloride</b>	Less than 300 ppm	300 - 600 ppm			
<b>Total Dissolved Solids</b>	Less than 1000 ppm	1000 - 1500 ppm			
<b>Slime &amp; Algae</b>	Slime and algae can form under certain environmental conditions		Reduced heat transfer due to forming of insulating coating, or pitting due to corrosion	Chlorinated phenols. Other biocides. Chlorine by hypochlorites or by liquid chlorine	No treatment required

- Notes:**
1. The tremendous variety in water quality around the country makes the recommendation of a single best method of treatment impossible. Consult a local water treatment specialist for specific treatment recommendations.
  2. Cupro-nickel is recommended if iron bacteria is high, suspended solids or dissolved oxygen levels are high.
  3. If the concentration of these corrosives exceeds the maximum tabulated in the cupro-nickel column, then the potential for serious corrosion problems exists.

# Supply & Return Piping

## Pre-Installation Considerations

All units should be connected to supply and return piping in a two-pipe reverse return configuration. A reverse return system is inherently self-balancing and requires only trim balancing where multiple quantities of units with different flow and pressure drop characteristics exist in the same loop.

A direct return system may also work acceptably, but proper water flow balancing is more difficult to achieve and maintain.

1. The piping must comply with local codes.

**⚠ WARNING**

Polyolester Oil, commonly known as POE oil is a synthetic oil used in many refrigeration systems, and may be present in this Daikin product. POE oil, if ever in contact with PVC/CPVC will coat the inside wall of PVC/CPVC pipe causing environmental stress fractures. Although there is no PVC/CPVC piping in this product, please keep this in mind when selecting piping materials for your application, as system failure and property damage could result.

Supply and return runouts usually join the unit via short lengths of high pressure flexible hose which are sound and vibration isolators for both unit operating noise and hydraulic pumping noise.

- One end of the hose should have a swivel fitting to facilitate removal for service.

- Note:**
1. No unit should be connected to the supply and return piping until the water system has been cleaned and flushed completely, see "Cleaning & Flushing System" on page 29. After the cleaning and flushing has taken place, the initial connection should have all valves wide open in preparation for water system flushing.
  2. Hard piping is not recommended since no vibration or noise attenuation can be accomplished.
  3. Supply and return shutoff valves are required at each unit. The return valve can be used for balancing. When used it should have a "memory stop" so that it can be closed off, and reopened to the proper position for the required flow.
  4. Do not over-torque fittings. The maximum torque without damage to fittings is 30 foot pounds. If a torque wrench is not available, use as a rule of thumb, finger tight plus one quarter turn.

Figure 5: Example of a reverse return piping system

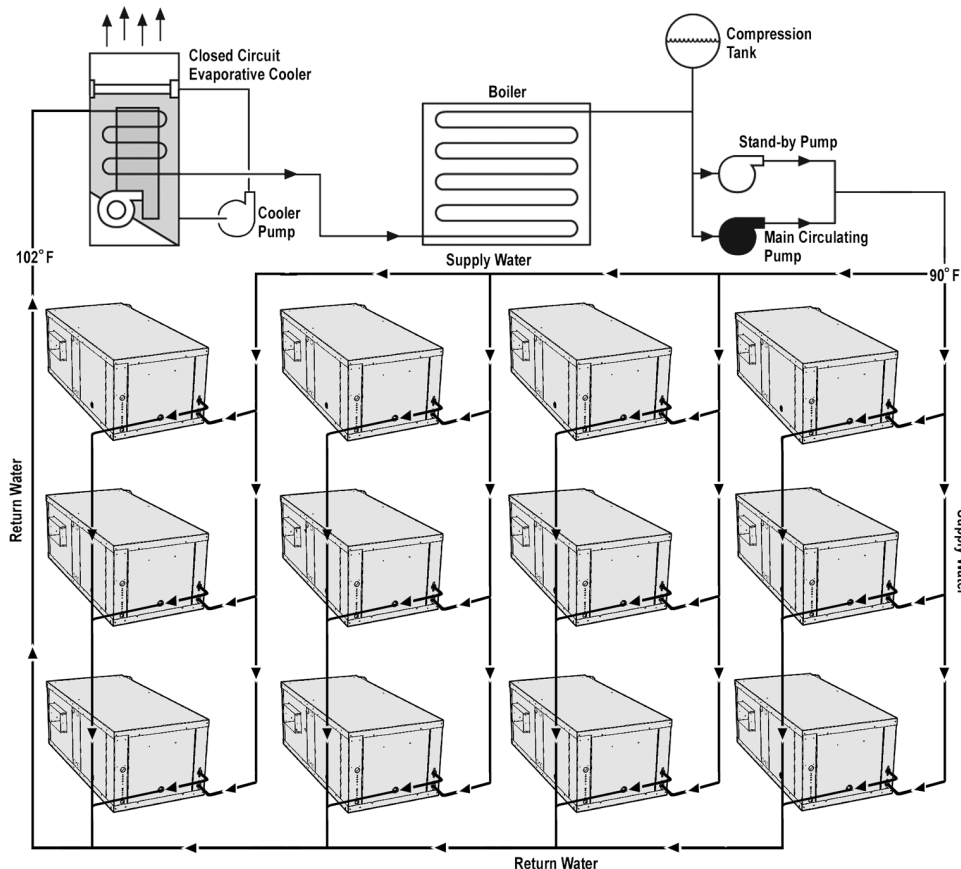

### Installation Considerations

2. Locate the unit in conditioned space and avoid installation in corrosive environments. Allow clearance for easy removal of the filter and access panels, and enough space for service personnel to perform maintenance or repair.
3. Remove the Styrofoam shipping block under the fan housing before start-up. [Figure 6](#).
4. Make sure that sufficient access has been provided for installing and removing the unit, including clearance for duct collars and fittings at water and electrical connections (see [Figure 10](#)).
5. Unit condensate drains are not internally trapped. External trap is required. Allow adequate room around the unit for condensate piping.
6. If the unit is installed in a confined space, provisions must be made for return air to freely enter the face of the unit's air coil.

Figure 6: Horizontal unit foam shipping block

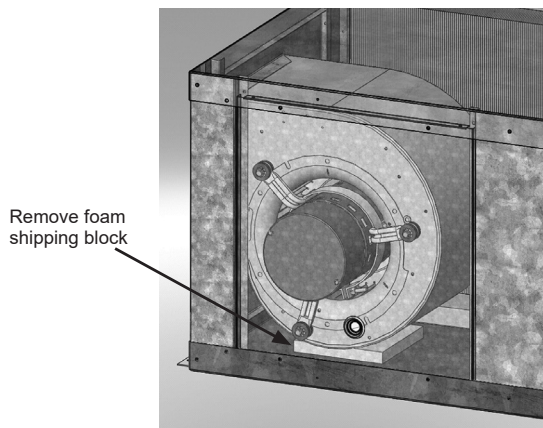

### Discharge Air Conversion

A straight discharge unit may be converted to an end discharge by doing the following:

**Note:** *The information covered in this section of the blower assembly orientation is typical of Daikin units. Regardless, if you are changing end to straight or straight to end the blower assembly has to turn 90 degrees and simultaneously rotate 180 degrees to achieve the proper orientation. Not all Daikin units will have the same air discharge location but will have the same general results when following the instructions.*

**DANGER**

Hazardous Voltage! Disconnect all electric power including remote disconnects before servicing. Failure to disconnect power before servicing can cause severe personal injury or death.

**CAUTION**

Sharp edges can cause personal injury. Avoid contact with them.

7. Turn off power to the unit at the breaker box.
8. Remove the top panel by removing the screws around the perimeter of the top securing it to the lower cabinet ([Figure 7 on page 15](#)).

**Note:** *Retain all screws for reinstalling.*

9. Remove the access panel to the fan motor by loosening the two (2) screws at the bottom holding the panel ([Figure 7 on page 15](#)). Remove the piece of insulation at the bottom on the side of the bottom panel.

Figure 7: Remove top and access panel to fan motor

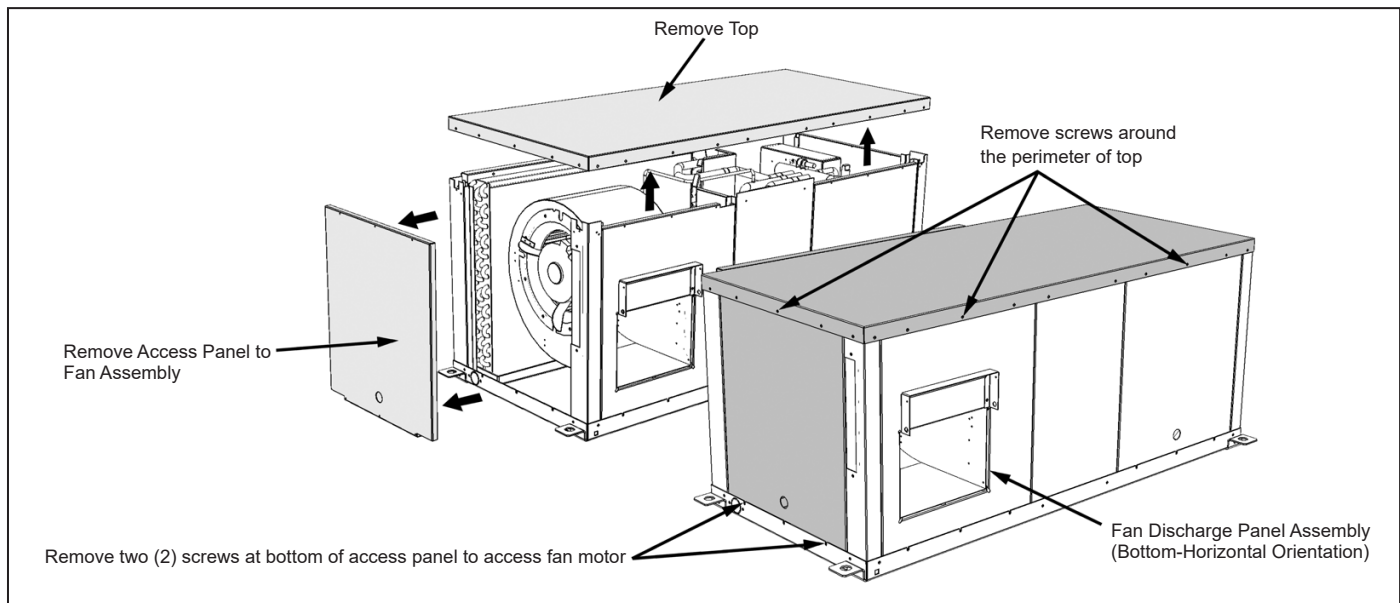

### Discharge Air Conversion (Continued)

Remove the screws securing the fan discharge panel assembly (Figure 7).

- Lift the fan assembly out rotating it 180 degrees and position it within the opening at the end of the unit (Figure 8). With the fan motor in the end discharge position the fan and housing orientation is top-horizontal. In a straight air discharge arrangement the housing is in the bottom-horizontal orientation.

- Secure the fan assembly to the unit frame with the screws removed previously.
- Reinstall the access panel in the fan motor access opening (Figure 9 on page 16).
- Reinstall the top panel and secure with screws removed previously.

**Note:** *If installed correctly the fan motor should be accessible when the fan motor access panel is removed.*

Figure 8: Lift out the fan assembly, turn 90 degrees and rotate 180 degrees

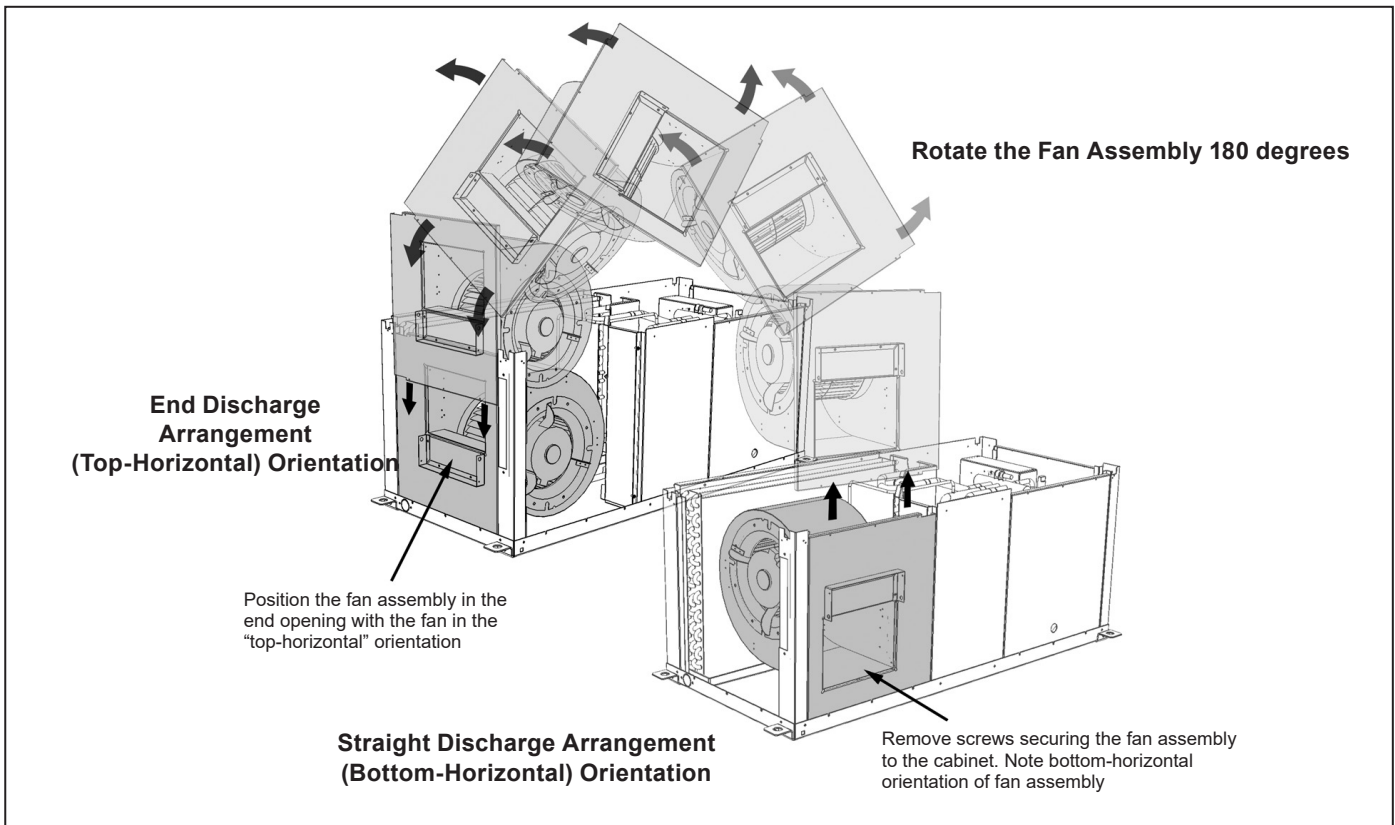
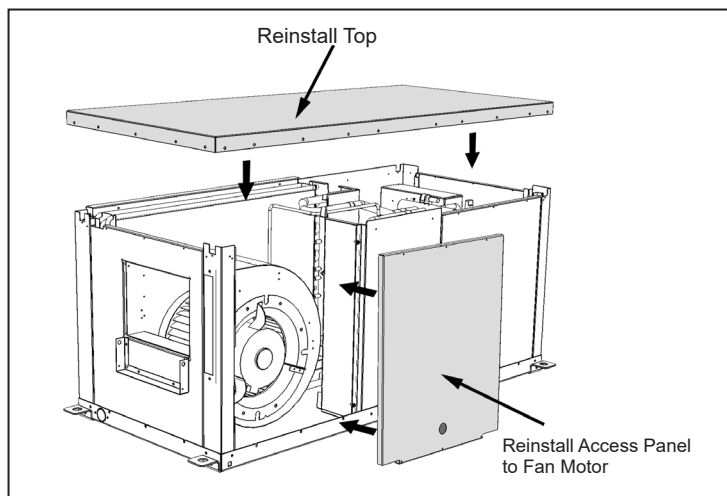
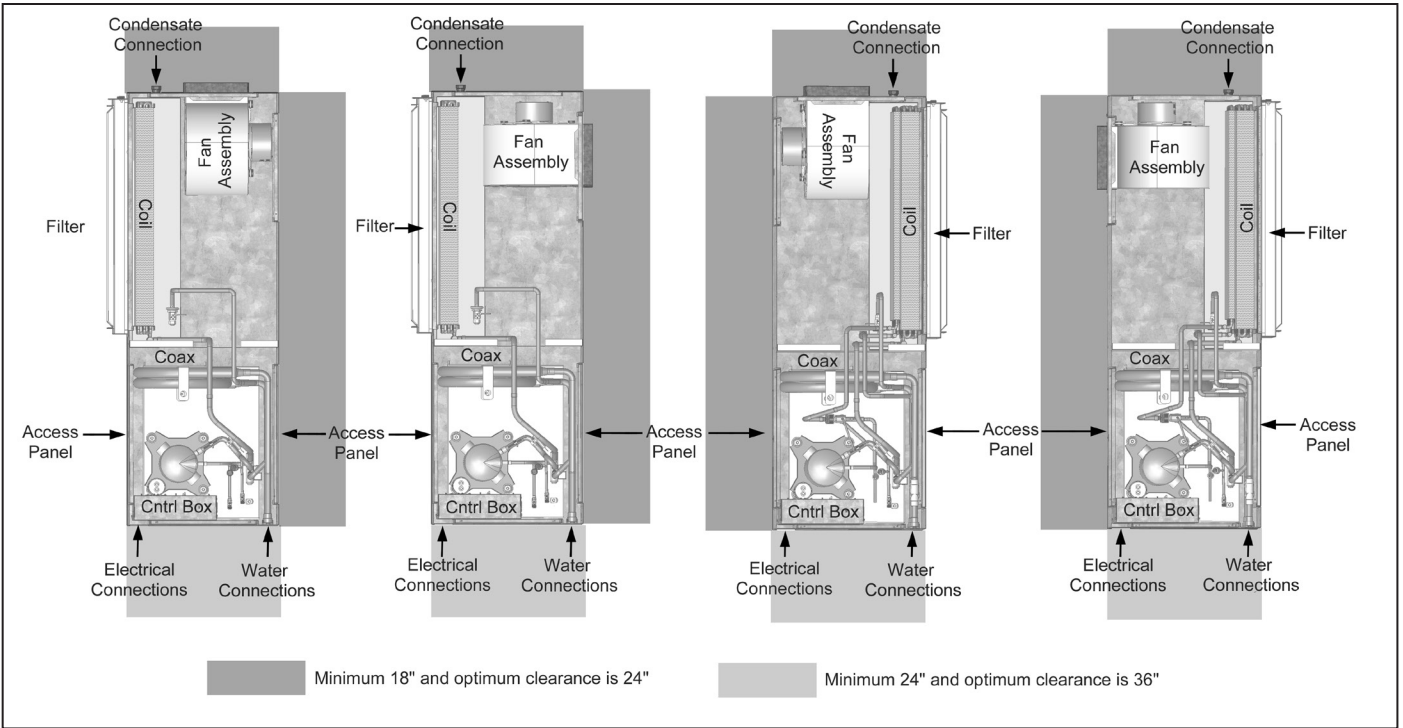

Figure 9: Reinstall the top and access panel



**Figure 10: Recommended minimum & optimum unit clearances**



## Hanger Brackets

**Figure 11: Hanger bracket locations - sizes 026-072**



**Figure 12: Hanger bracket details (sizes 007-019)**

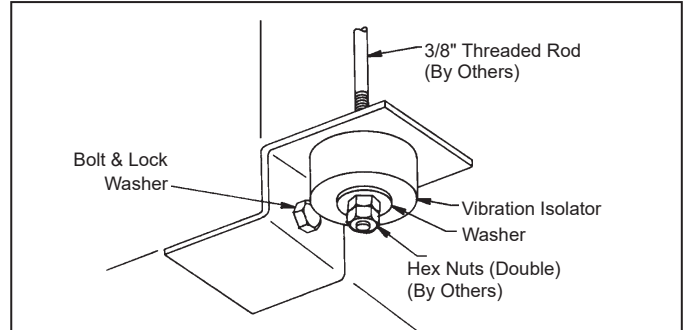
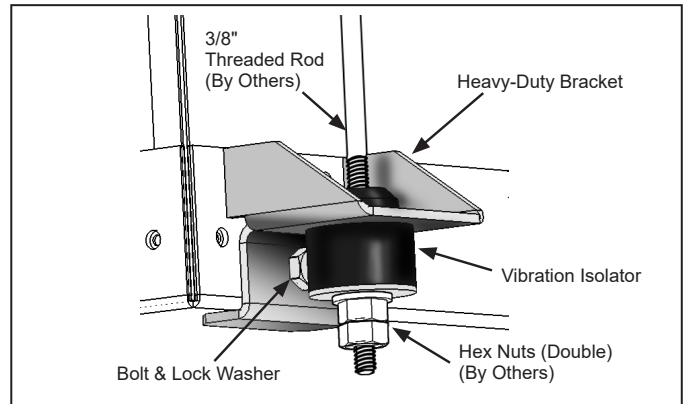

**Table 9: Hanger bracket location dimensions, in inches (mm)**

Unit Size	W	X	Y
007, 009, 012	44.67 (1135)	23.60 (599)	19.10 (485)
015, 019	50.06 (1272)	24.40 (620)	19.90 (505)
024, 026, 030, 032	62.16 (1579)	23.90 (607)	18.64 (474)
036, 038	72.16 (1833)	27 (686)	21.24 (539)
042, 044, 048	77.57 (1970)	27 (686)	21.24 (539)
060, 064, 070, 072	82.97 (2107)	27 (686)	21.24 (539)

**Note:** All dimensions within  $\pm 0.10$  inches (2.5 mm).

**Figure 13: Heavy-duty hanger brackets (sizes 024-072)**



Horizontal unit sizes 024 through 072 are provided with heavy-duty hanger brackets, fastening bolts, vibration isolators and washers. Do not substitute these brackets for others, for unit sizes 024 through 072. 3/8" threaded rods and hex nuts (doubled) are provided by others.



**WARNING**

Clearance should be maintained to meet local and national code requirements.

**Figure 14: Typical ducting of horizontal unit**

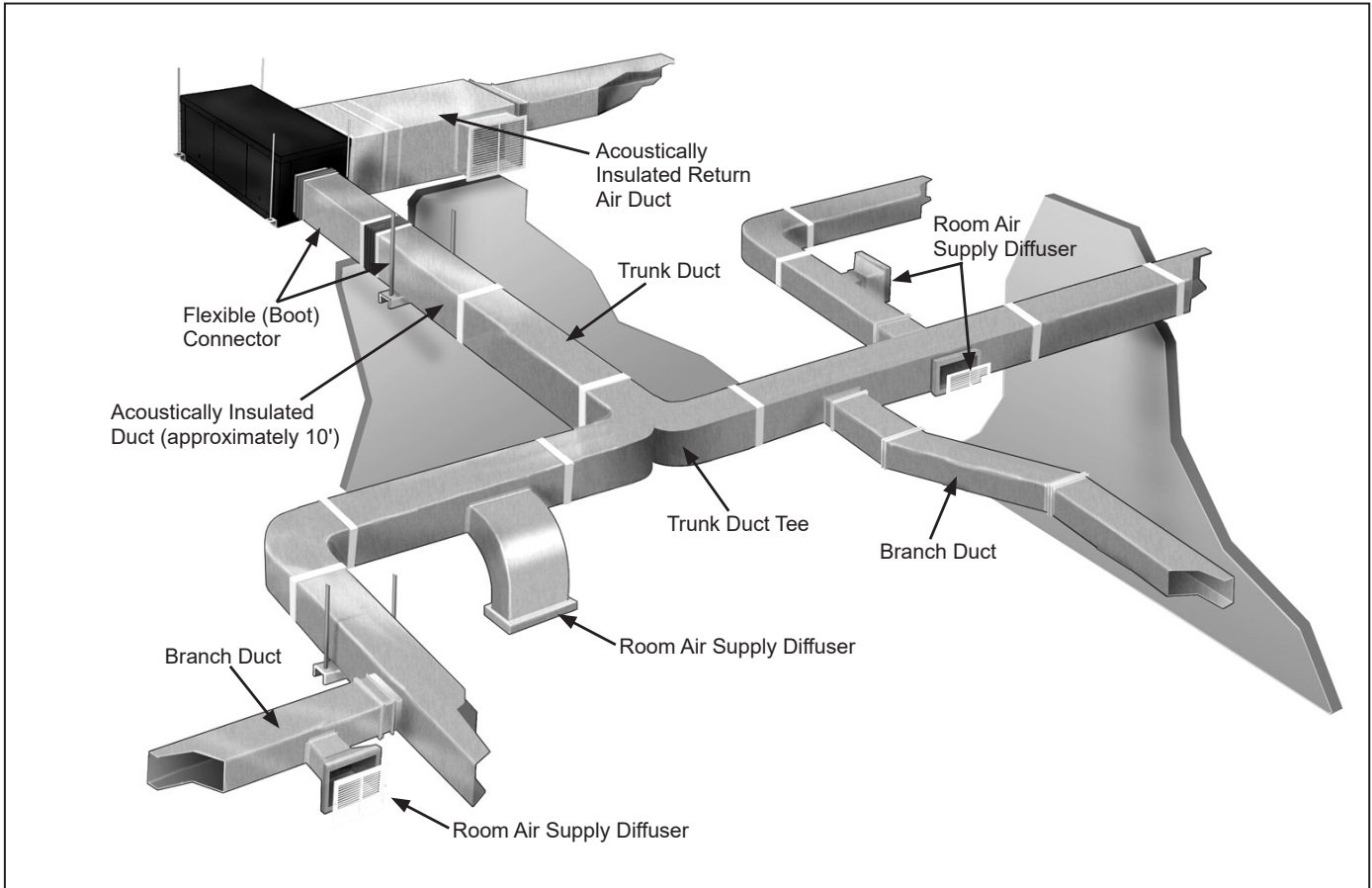

**Ductwork and Attenuation**

Discharge ductwork is normally used with these conditioners. Return air ductwork may also be required.

All ductwork should conform to industry standards of good practice as described in the ASHRAE Systems Guide.

A field supplied discharge duct system will normally consist of:

- a flexible connector at the unit
- a 10 ft. length of insulated duct
- and a trunk duct teeing into a branch duct with discharge diffusers as shown in [Figure 14](#)

With metal duct material, the entire branch duct should be internally lined with acoustic fibrous insulation for sound attenuation. Glass fiber duct board material is more absorbing and may permit omission of the flexible boot connector.

As a general recommendation, the acoustic fibrous insulation should be at least 1/2 inch thick over the entire duct run ([Figure 14](#)). For better sound attenuation, line the last five diameters of duct before each register

with a one-inch thick sound blanket. Elbows, tees and dampers can create turbulence or distortion in the airflow. Place a straight length of duct, 5 to 10 times the duct width, before the next fitting to smooth out airflow. Diffusers that are located in the bottom of a trunk duct can also produce noise. For this same reason, volume control dampers should be located several duct widths upstream from an air outlet.

For Hotel, Motel, Dormitory or Nursing Home applications that use a single duct discharge, a velocity of 500 to 600 fpm is suggested. These applications typically have static pressures as low as 0.05 inches of water and duct lengths approximately six feet in length. The discharge duct must be fully lined and have a square elbow without turning vanes. Return air for these applications should enter through a “low” sidewall filter grille and route up the stud space to a ceiling plenum. For horizontal heat pumps mounted from the ceiling, an insulated return plenum is sometimes placed at the return air opening to further attenuate line-of-sight sound transmission through return openings.

# Duct Location Dimensions

Figure 15: Discharge duct collar location

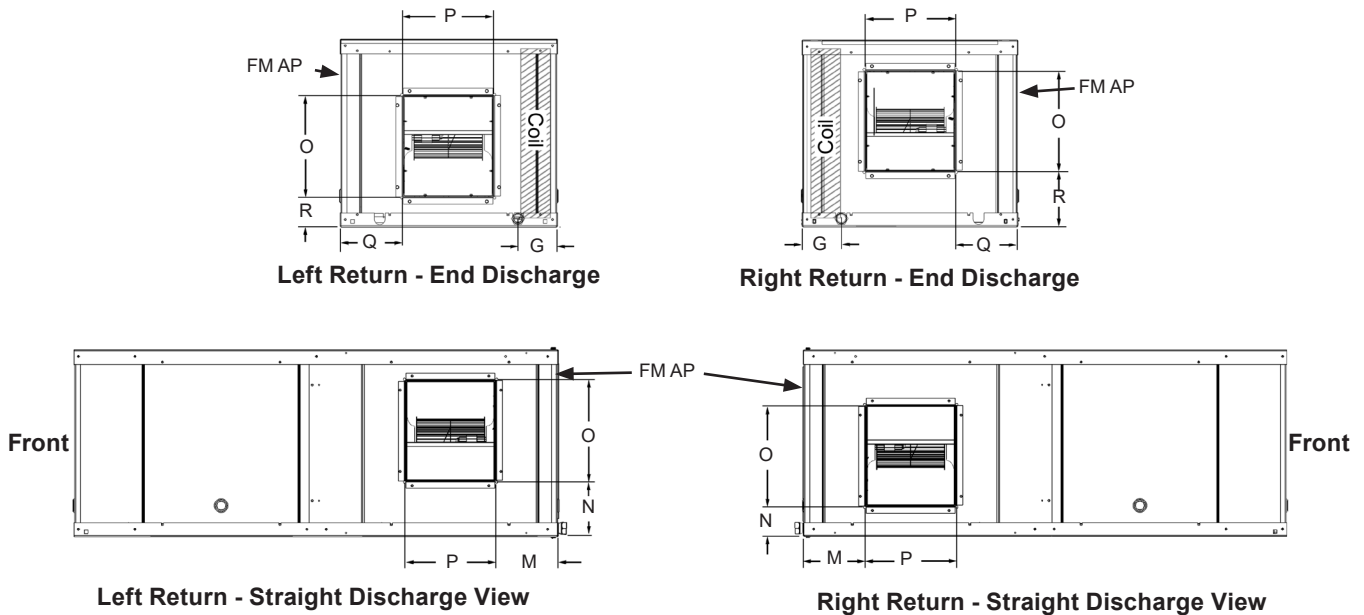

Legend: FM AP = Fan Motor Access Panel

Table 10: Discharge duct collar dimensions, in inches (mm)

GSH Horizontal Unit	Discharge Air Duct Connection in inches (mm)							
	M	N		O	P	Q	R	
		Left-hand	Right-hand				Left-hand	Right-hand
007, 009, 012	6.18 (157)	4.25 (108)	8.09 (206)	4.89 (124)	9.45 (240)	6.12 (156)	8.09 (206)	4.25 (108)
015, 019	4.64 (118)	5.75 (146)	3.15 (80)	10.46 (266)	9.33 (237)	4.63 (118)	3.15 (80)	5.75 (146)
024, 026, 030, 032	4.41 (112)	6.20 (157)	2.71 (69)	10.39 (264)	9.32 (237)	4.41 (112)	2.71 (69)	6.20 (157)
036, 038	4.88 (124)	4.74 (120)	2.81 (71)	13.75 (349)	13.25 (337)	4.88 (124)	2.81 (71)	4.74 (120)
042, 044, 048, 049	4.88 (124)	4.74 (120)	2.81 (71)	13.75 (349)	13.25 (337)	4.88 (124)	2.81 (71)	4.74 (120)
060, 064, 070, 072	4.88 (124)	4.74 (120)	2.81 (71)	13.75 (349)	13.25 (337)	4.88 (124)	2.81 (71)	4.74 (120)

Note: All duct dimensions are referenced from the outside edge of the flange.

Figure 16: Return air duct collar location

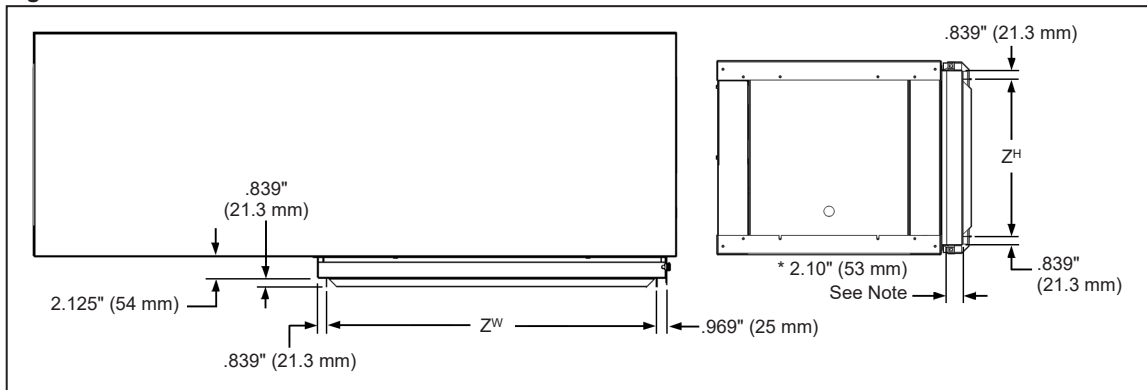

Table 11: GSH horizontal unit 2" (51mm) filter rack assembly & duct collar dimensions, in inches (mm)

Dimension	Unit Size					
	007, 009, 012	015, 019	024, 026, 030, 032	036, 038	042, 044, 048, 049	060, 064, 070, 072
Z <sup>h</sup>	13.91 (353)	16.49 (419)	15.45 (392)	17.45" (443)	17.45 (443)	17.45 (443)
Z <sup>w</sup>	19.35 (491)	23.38 (594)	32.51 (826)	35.76" (908)	41.15" (1045)	46.55" (1182)

Note: \* Optional 4" filter rack = 4.10" (104 mm)

## Return Air Filter Rack Assembly & Duct Collar Connections

Return air ductwork can be connected to the standard filter rack, see [Figure 16 on page 19](#). The unit comes standard with a 2" (51mm) thick factory-installed throwaway filter, mounted in a 4-sided combination filter rack and return air duct collar. Filters can be easily removed from either side by interchanging the removable filter door to the right or left side and rotating the filter rack assembly 180 degrees. Do not use sheet metal screws directly into the unit cabinet for connection of supply or return air ductwork, especially return air ductwork which can hit the drain pan or the air coil.

**Figure 17: Filter rack filter door removal**

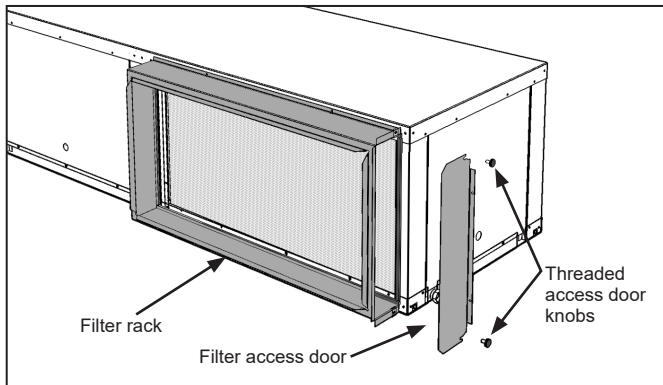

## Ventilation Air

Ventilation may require outside air. The temperature of the ventilation air must be controlled so that mixture of outside air and return air entering the conditioner does not exceed conditioner application limits. It is also typical to close off the ventilation air system during unoccupied periods (night setback).

The ventilation air system is generally a separate building subsystem with distribution ductwork. Simple introduction of the outside air into each return air plenum chamber reasonably close to the conditioner air inlet is recommended. Do not duct outside air directly to the conditioner inlet. Provide sufficient distance for thorough mixing of outside and return air. See "Operating Limits" on page 47.

## Unit Piping and Electrical Connections Dimensions

**Figure 18: Piping & electrical connections locations**

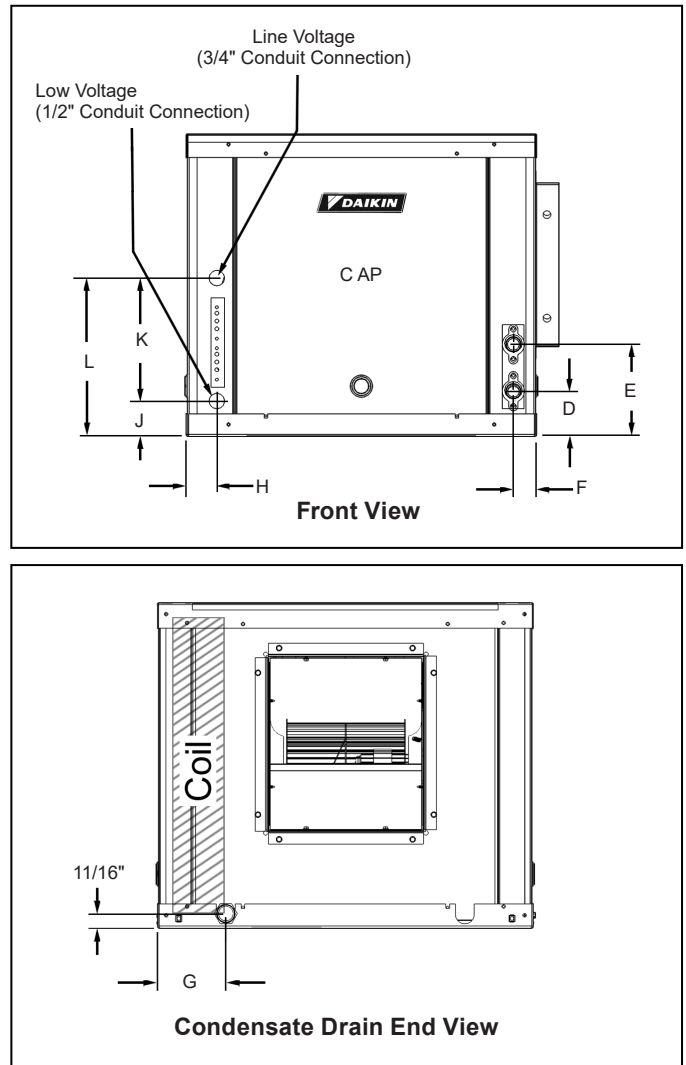

**Legend:** C AP = Control Access Panel

**Table 12: Piping & electrical connections dimensions, in inches (mm)**

GSH / GTH Horizontal Unit	Piping Connections in inches (mm)				Electrical Connections in inches (mm)				
	D	E	Supply & Return Connections FPT	F	G	H	J	K	L
	Supply	Return			Condensate Drain 3/4" FPT		Low Voltage		
007, 009, 012	2.65 (67)	5.65 (144)	1/2"	1.47 (37)	3.76 (96)	1.98 (50)	2.08" (53)	7.06 (179)	9.14 (232)
015, 019	2.95 (75)	5.95 (151)	3/4"	1.47 (37)	4.07 (103)	1.98 (50)	2.08 (53)	7.06 (179)	9.14 (232)
024, 026, 030	2.58 (66)	13.39 (340)	3/4"	1.57 (40)	4.29 (109)	1.94 (49)	2.57 (65)	7.36 (187)	9.93 (252)
036, 038	2.76 (70)	13.57 (345)	3/4"	1.57 (40)	4.36 (111)	1.94 (49)	3.57 (91)	8.23 (209)	11.81 (300)
042, 044, 048, 049,	3.07 (78)	13.88 (353)	1"	1.57 (40)	4.36 (111)	1.94 (49)	3.57 (91)	8.23 (209)	11.81 (300)
060, 064, 070, 072,	3.07 (78)	13.88 (353)	1"	1.57 (40)	4.36 (111)	1.94 (49)	3.57 (91)	8.23 (209)	11.81 (300)



# Waterside Economizer Piping Connections

Figure 19: Waterside economizer unit descriptions

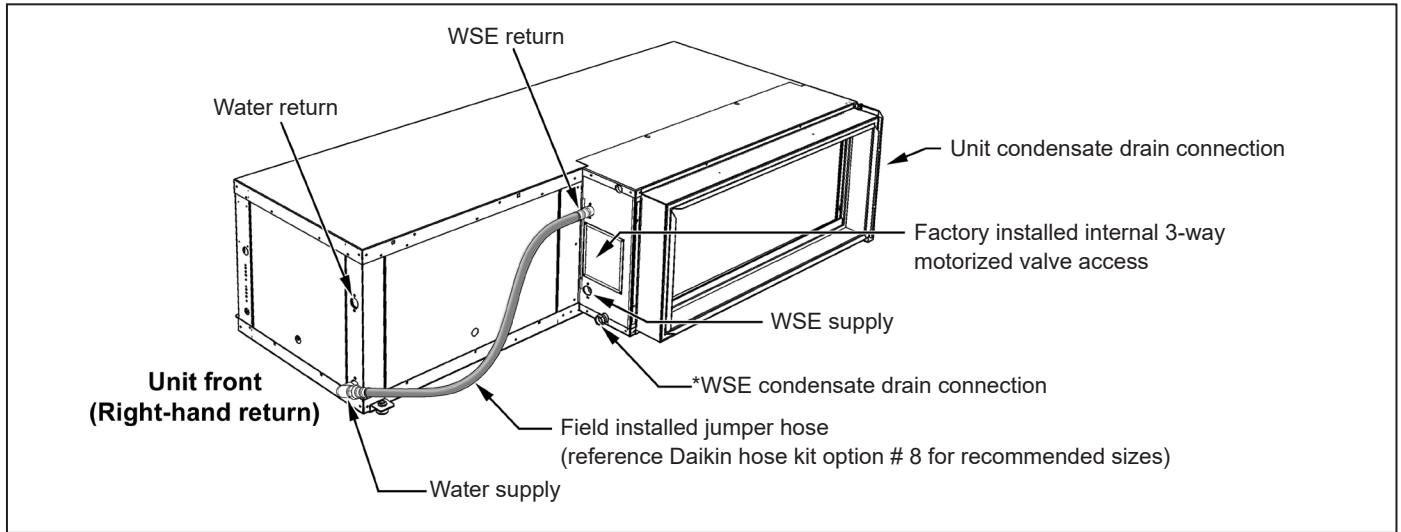

**Note:** \*The economizer package incorporates its own drain pan to collect condensate from the coil. This pan **MUST** be independently trapped and piped into the drain line for the heat pump.

Figure 20: Waterside economizer piping location dimensions

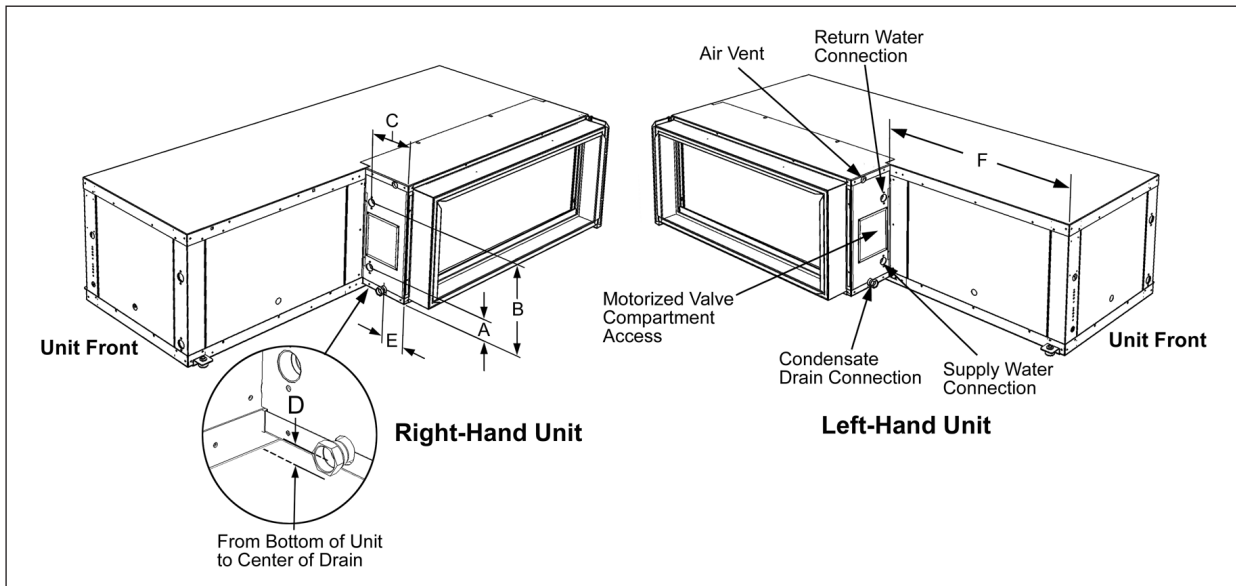

Unit Size	GSH / GTH Horizontal Unit							
	Supply & Return Connections				Condensate Connections			F
	A	B	C	FPT	D	E	FPT	
007, 009, 012	3.50	9.29	6.36	1/2"	1.38	4.25	3/4"	22.58
015, 019	3.50	10.88	6.89	3/4"	0.88	4.25		24.94
024, 026, 030, 032	3.36	9.38	7.23	3/4"	1.70	4.25		27.19
036, 038	2.94	14.07	7.42	3/4"	1.70	4.25		33.93
042, 044, 048, 049	2.94	14.07	7.42	1"	1.70	4.25		33.65
060, 064, 070, 072	2.94	14.07	7.42	1"	1.70	4.25		33.67

# Electrical Connections

## ⚠ WARNING

All field installed wiring must comply with local and national electric codes. This equipment presents hazards of electricity, rotating parts, sharp edges, heat and weight. Failure to read and follow these instructions can result in property damage, severe personal injury or death. This equipment must be installed by experienced, trained personnel only.

## ⚠ CAUTION

Fasteners should not be screwed into and penetrate the unit enclosure to avoid damage to internal electrical and mechanical components.

## ⚠ WARNING

Use copper conductors only. Conductors must be minimum 75°C.

**Table 13: Operating voltages**

Voltage	Minimum	Maximum
115/60/1	103	126
208-230/60/1	197	253
265/60/1	238	292
208-230/60/3	197	253
460/60/3	414	506

**Note:** Three-phase system imbalance shall not exceed 2%.

- Use a short length of flexible conduit at the unit connection to minimize and isolate vibration to the building. All conduit should be supported to avoid contact with unit cabinet or immediate building structure to prevent unnecessary noise.

## ⚠ CAUTION

All electrical connections should be checked for tightness as they may come loose during shipment.

## Line Voltage – 208-230, 460

**Note:** 460V units require a neutral conductor. See Figure 21.

1. Route line voltage supply wiring through the upper 1-1/8" diameter knockout in the left corner post.
2. Remove and discard the factory provided stripped wire leads from the bottom unit contactor screw terminals (not shown).
3. Connect the field supplied wires to the lower contactor screw terminals as shown in Figure 21.
4. Twist neutral wires and wire nut (460V units only)
5. Connect ground wire to provided (green) ground screw

## 230 Volt Operation

All 208-230 volt single-phase and three-phase units are factory wired for 208 volt operation. For 230 phase operation, the line voltage tap on the 24 volt transformer must be changed. Disconnect and cap the red lead wire and interchange it with the orange lead wire on the primary of the 24 volt transformer

**Figure 21: Route line voltage wires to terminal screws.**

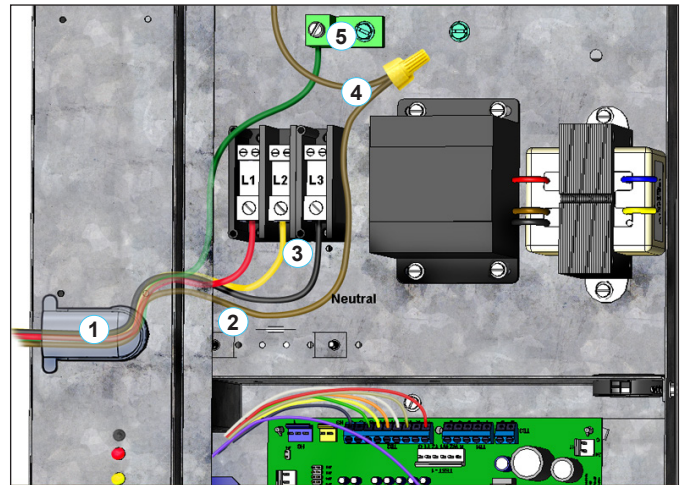

**Note:** Units without constant EC motor will not include a neutral conductor. For clarity, not all unit wires are shown in the unit line voltage connection area.

## Line Voltage – 115V

1. Route line voltage supply wiring through the upper 1-1/8" diameter electrical knockout in the left corner post. Figure 22.
2. Continue to route wires into the control box.
3. Connect and wire nut the supply wires to provided unit leads as shown in Figure 22.
4. Secure ground wire to (green) ground screw.

**Figure 22: Line voltage wiring route to wire connections**

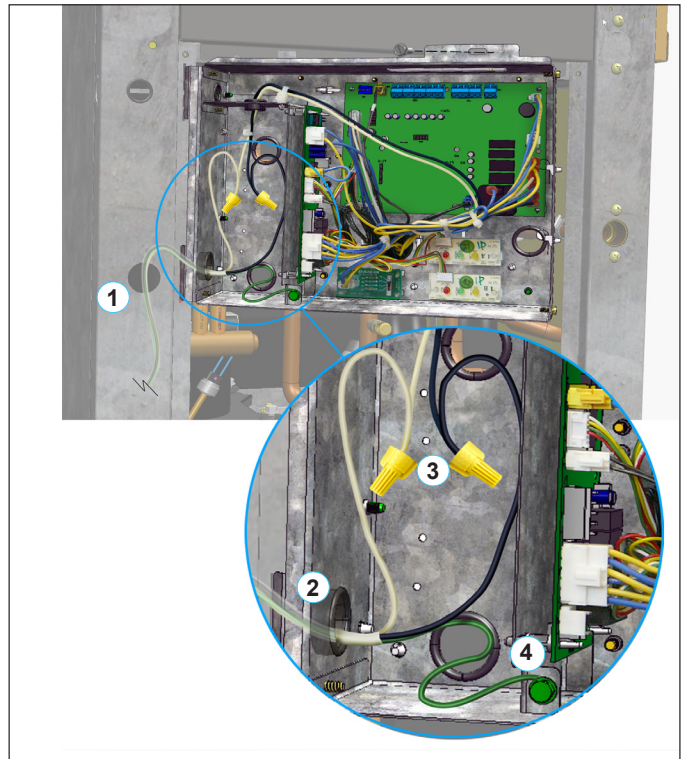

## GSH/GTH Unit With Non-Fused Disconnect Switch

Figure 23: Unit with optional non-fused disconnect switch

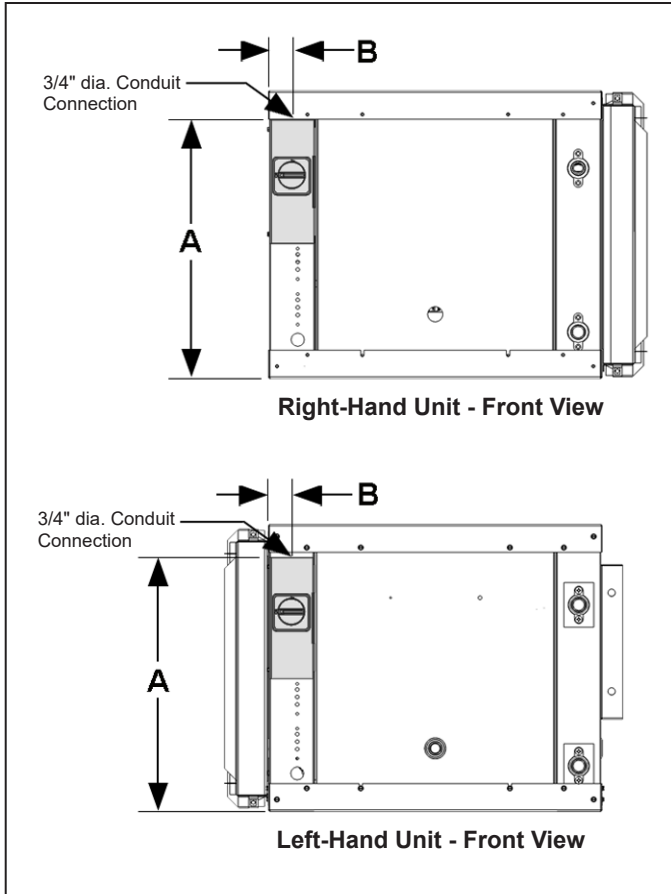

Table 14: Letter dimensions for Figure 23.

Unit Size	A	B
007, 009, 012	16-1/4"	1-1/2"
015, 019		
024, 026, 030, 032	17-3/4"	
036, 038, 042, 044	19-1/4"	
048, 049, 060, 064, 070, 072		

## Line Voltage Electrical Connections With Disconnect – 115-460V

When units are equipped with the optional non-fused disconnect switch, the line voltage supply is brought in through the top of the junction box. Disconnect location and dimension details are provided in Figure 23.

**Note:** \*460V units require a neutral conductor. See #6 in Figure 24.

1. Remove screws from the top and bottom locations on the disconnect switch cover.
2. These are the factory-installed wires from the switch to the line voltage terminals in the unit control box.
3. Connect wires to the upper unused terminals.
4. Tighten terminal screws to secure wires.
5. Connect ground wire to provided green ground screw.
6. Twist and wire nut field provided neutral conductor.

Replace cover and secure with screws.

Figure 24: 460V wiring with neutral wire to the non-fused disconnect switch

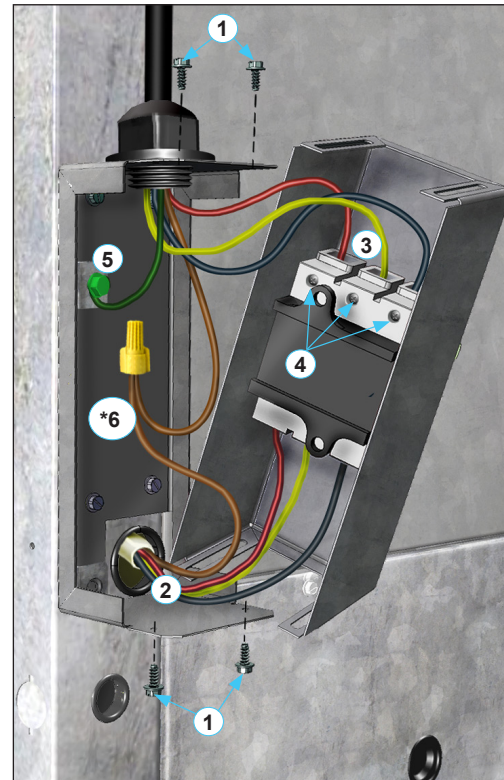



## Low Voltage Wire Connections

### Procedure

**Note:** 1. Never install relays coils in series with the thermostat inputs.  
 2. Units equipped with HGRH and using thermostat control require installation of a factory supplied return air sensor connected to H9 terminal. See [Figure 29 on page 25](#) for details.

1. Remove front access panel to allow access to the control box.
2. Route the field-supplied low voltage wiring through the lower knockout in the left corner post and into the control box section as shown in [Figure 25](#).
3. Secure the low voltage wire connections to the main board terminals on TB2
4. Secure wire to TB1-1 on the I/O expansion module.
5. Reinstall the access panel after connections are complete and wire terminals have been checked for tightness.

**Figure 25: Low voltage wiring route & connections**

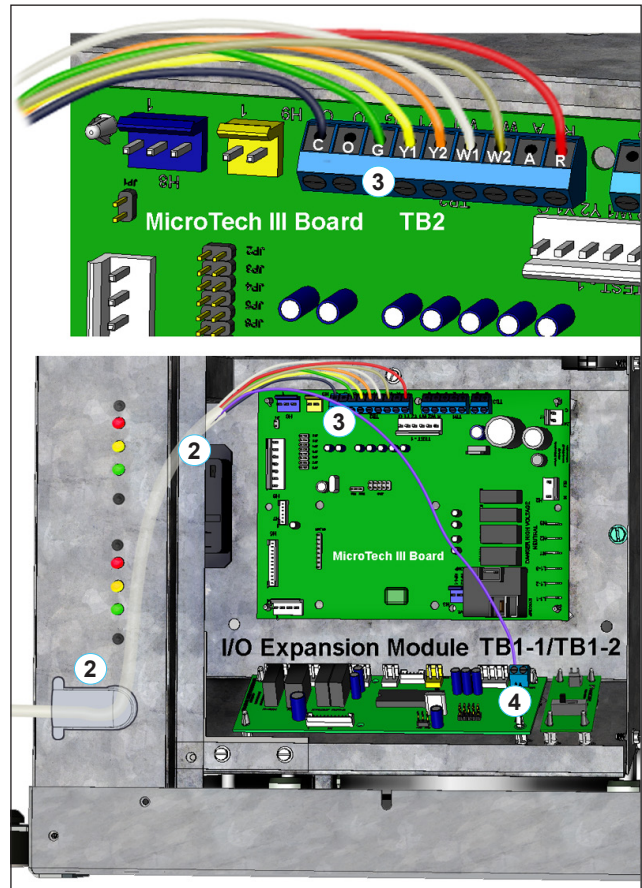

**Figure 26: Terminal connections to TB1 (sensor control) on the MTIII board**

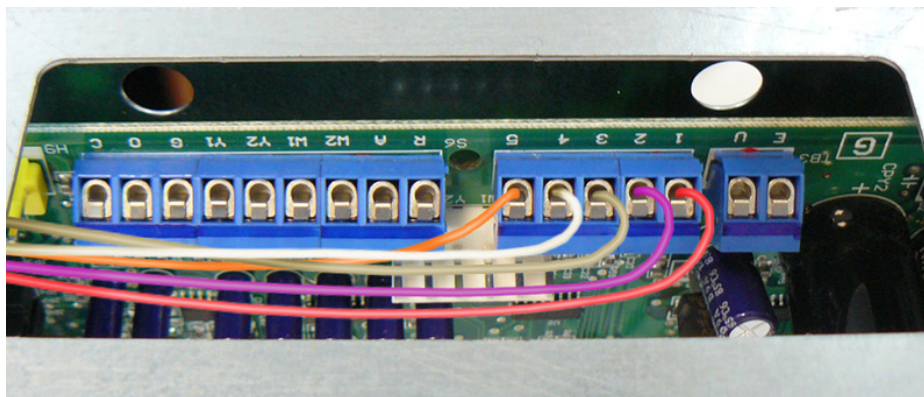

Figure 27: Units that utilize thermostat control, a factory supplied return air sensor connects to the H9 terminal.

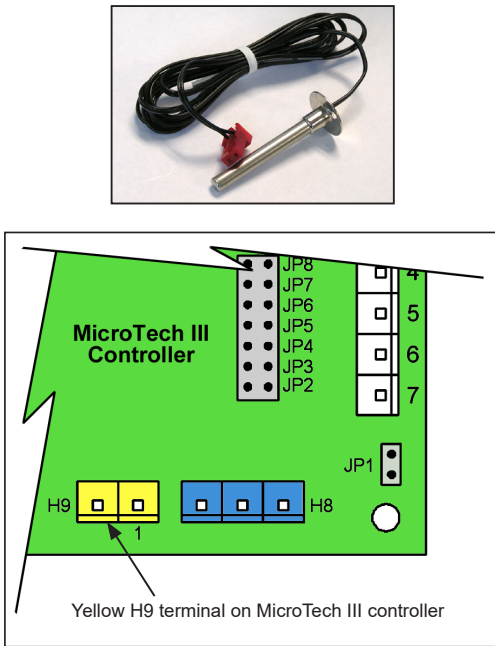
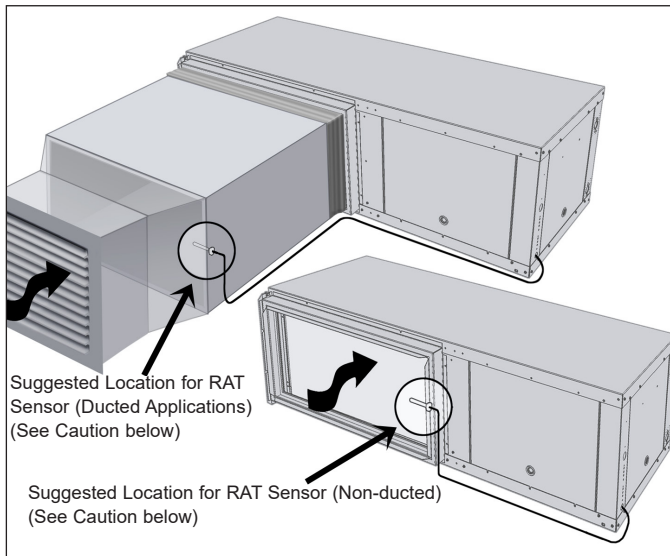

Figure 28: Return Air Temperature sensor (RAT) locations



**CAUTION**

When an optional wall-mounted room temperature sensor is connected to the unit controller, the Return Air Temperature (RAT) sensor must not be installed. A wall-mounted room temperature sensor and the return air temperature sensor must not be connected simultaneously or the unit will not operate properly.

**Note:** For single stage operation wire Y1 from thermostat to Y2 terminal on the Microtech III control board.

Figure 29: Digitally adjustable room temperature sensor wiring

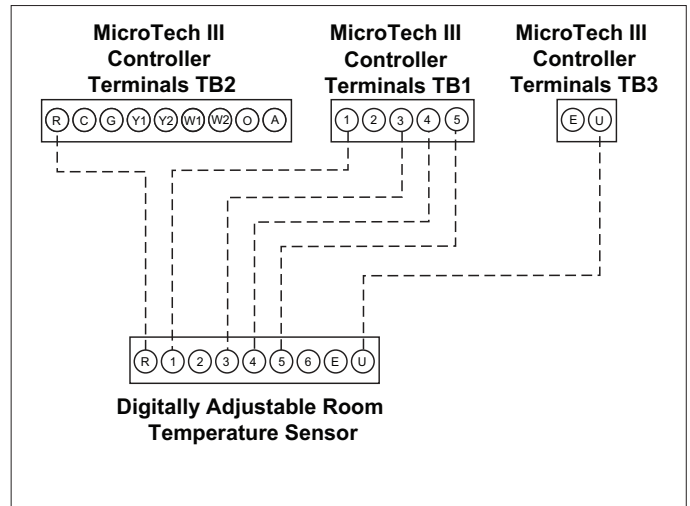
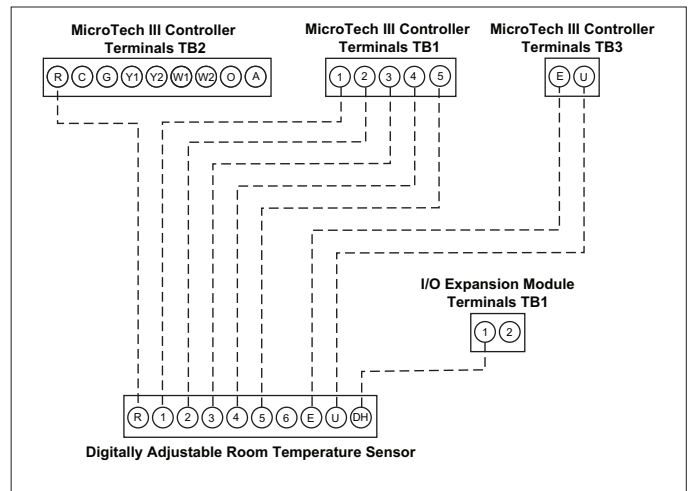





Figure 30: Digitally adjustable room temperature and humidity sensor wiring



**Note:** Terminal TB1-1 is used for optional dehumidification operation.



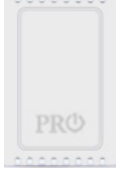

# Thermostats and Remote Indoor Sensor

Table 15: Thermostat Selections

Wall Mounted Thermostats & Remote Sensor for use with all WSHP units: Console, V-Stack, Enfinity & SmartSource models		Thermostats				Remote Sensor
		Non-Programmable	Programmable (7 Day or 5+1+1) Non-Programmable		7 Day Programmable Non-Programmable	Remote Indoor Thermostat Sensor
		2H/2C	2H/2C	2H/3C Humidity Control	2H/3C Humidity Control WIFI	
						
Daikin Part Number		910411879	910411880	910417943	910417944	910420874
Feature						
LCD Display	Room Temperature & Setpoint	•	•	•	•	Allows Remote Temperature Sensing
	Room Humidity %			•	•	
Glow in the dark Display light		•	•	•	•	
Operating Modes	System	Heat-Off-Cool-Auto	Heat-Off-Cool-Auto	Heat-Off-Cool-Auto	Heat-Off-Cool-Auto	Use up to 16 sensors for temperature averaging
	Fan	On-Auto	On-Auto	On-Auto-IAQ	On-Auto-IAQ	
Changeover	Manual	•	•	•	•	
	Auto	•	•	•	•	
Temperature Control Range		44° F to 90° F (7° C to 32° C)	44° F to 90° F (7° C to 32° C)	44° F to 90° F (7° C to 32° C)	44° F to 90° F (7° C to 32° C)	
Adjustable Setpoint Limits		•	•	•	•	
Keypad Lockout				•	•	
Filter Change Reminder			•	•	•	
Programmable Fan		•	•	•	•	
Power Type	Battery	2 AA Alkaline Batteries				
	Hardwire (Common Wire)	18 to 30 VAC	18 to 30 VAC	18 to 30 VAC	18 to 30 VAC	
Permanent Memory Retention		•	•	•	•	
Remote Indoor Sensor Capable (Requires Daikin P/N: 910420874)			•	•	•	
Terminals		Rh, RC, G, Y, Y2, C, O, B, W/E, W2	Rh, RC, C, Y, Y2, W/E, W2, G, B, O, S1, S2	Rh, RC, C, Y, Y2, W/E, W2, G, B, O, S1, S2, H, D	Rh, RC, C, Y, Y2, W/E, W2, G, B, O, S1, S2, H, D	
Application						
Dehumidification	Smart Dehumidification			•	•	
	Simplified	•	•	•	•	
	Humidistat Controlled			•	•	
Electric Heat	Boilerless	•	•	•	•	
	Supplemental	•	•	•	•	
	Primary	•	•	•	•	
Waterside Economizer		•	•	•	•	
Hydronic Heat		•	•	•	•	

# Room Temperature Sensors

**Table 16: Room Temperature Sensors for BAS Operation**

		Room Temperature Sensors			
		Basic Room Sensor	Cool to Warm Adjust	Digitally Adjustable Display Sensor	
<p>Room Sensors for use with all WSHP units with a BACnet or LonWorks Communication Module: Console, V-Stack, Enfinity &amp; Smart-Source models</p>					
		Temperature Sensing, LED Status Indication, Override/Reset Button	Cool/Warm Temperature Sensing Adjustment, LED Status Indication, Override/Reset Button	Temperature, Occupancy, Alarm, Setpoint and Status display, Override/Reset and Occupied/Unoccupied Buttons	Temperature, Humidity, Occupancy, Alarm, Setpoint and Status display, Override/Reset and Occupied/Unoccupied Buttons
Daikin Part Number		910152149	910171464	910152147	910121754
Feature					
Setpoint Adjustment		None	Cool to Warm	Digitally Adjustable	Digitally Adjustable
Display	Room Temperature & Setpoint			•	•
	Room Humidity & Setpoint				•
Stages	Heating	4	4	4	4
	Cooling	3	3	3	3
Operating Modes	System				Heat-Off-Cool-Auto Dehumidify
	Fan				On-Auto
	Occupancy			LCD Display of Occupied-Unoccupied Icon	LCD Display of Occupied-Unoccupied Icon
Annunciation	Status LED	•	•	LCD Display of Unit Status	LCD Display of Unit Status
	LCD Alarm Display			•	•
Reset	Alarm	•	•	•	•
	Setback Override	•	•	•	•
Application					
Dehumidification	Smart Dehumidification				•
Electric Heat	Boilerless	•	•	•	•
	Supplemental	•	•	•	•
	Primary	•	•	•	•
Waterside Economizer		•	•	•	•
Hydronic Heat		•	•	•	•

## Condensate Drain Connection

A field provided condensate trap must be installed on each water source heat pump. Condensate removal piping must be pitched away from the unit not less than 1/4" per foot. An air vent is sometimes required after the trap to prevent air pockets, so the condensate will drain away from the unit. The vent should extend at least 1-1/4" above the unit condensate fitting. The vent can also act as a clean out if the trap becomes clogged. To avoid having waste gases entering the building, the condensate drain should not be directly piped to a drain/waste/vent stack, etc. Always connect the drain through a trap to the condensate drain system in accordance to the local plumbing codes.

**Figure 31: Unit condensate drain pipe trap detail**

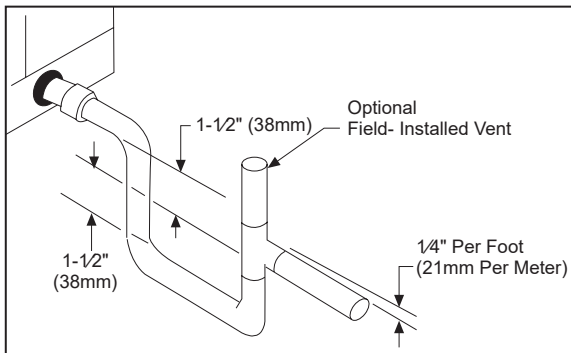

**Figure 32: Unit condensate drain pipe detail with waterside economizer option**

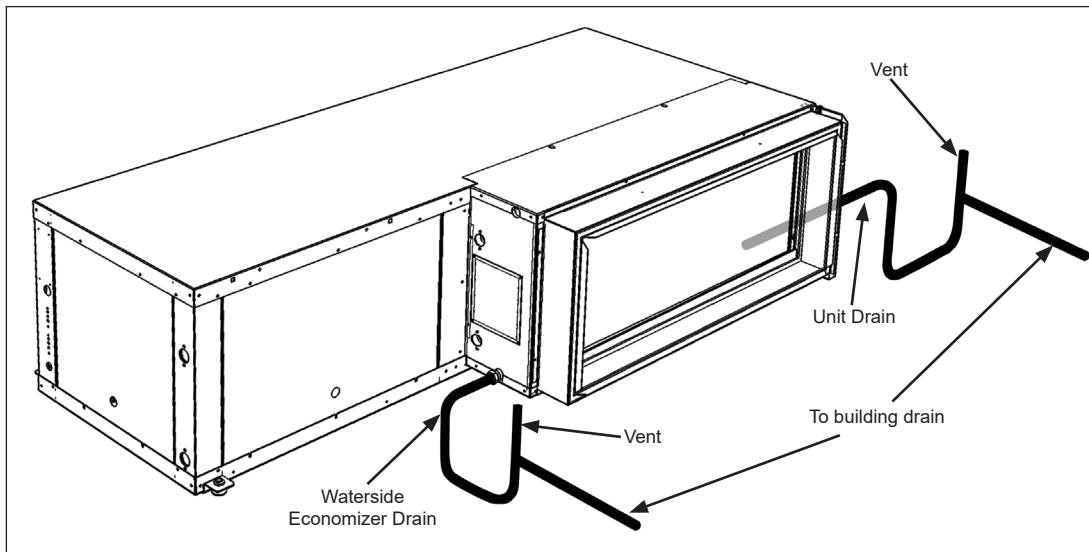

**Note:** *Improper trapping can lead to several problems. If the trap is too tall, negative pressure will prevent drainage, causing condensate backup. If the trap is too short the seal will be destroyed or nonexistent, producing the same effect as a non-trapped system.*

1. Each water source heat pump is provided with a 3/4" FPT flush mount fitting for connection of a condensate drain. A complete steel or copper condensate system can be used. Steel or copper condensate piping should be insulated to prevent sweating.
2. Do not locate any point in the drain system above the condensate drain connection of any unit.

It may be necessary to manually fill the trap at system startup, or to run the unit for sufficient time to build a condensate seal. The condensate trap and condensate piping drainage should be free of any foreign debris. Debris can prevent proper drainage and unit operation and result in condensate buildup.



## Cleaning & Flushing System

1. Prior to first operation of any conditioner, the water circulating system must be cleaned and flushed of all construction dirt and debris. If the conditioners are equipped with water shutoff valves, either electric or pressure operated, the supply and return runouts must be connected together at each conditioner location. This will prevent the introduction of dirt into the unit. See [Figure 33](#).

**Figure 33: Supply & return runouts connected together**

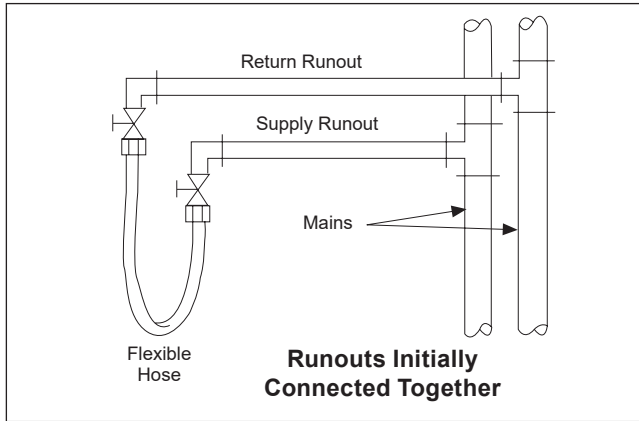

2. Fill the system at the city water makeup connection with all air vents open. After filling, close all air vents. The contractor should start main circulator with the pressure reducing valve open. Check vents in sequence to bleed off any trapped air, ensuring circulation through all components of the system. Power to the heat rejector unit should be off, and the supplementary heat control set at 80°F (27°C). While circulating water, the contractor should check and repair any leaks in the piping. Drains at the lowest point(s) in the system should be opened for initial flush and blowdown, making sure city water fill valves are set to make up water at the same rate. Check the pressure gauge at pump suction and manually adjust the makeup to hold the same positive steady pressure both before and after opening the drain valves. Flush should continue for at least two hours, or longer if required, to see clear, clean drain water.

3. Shut off supplemental heater and circulator pump and open all drains and vents to completely drain down the system. Short circuited supply and return runouts should now be connected to the conditioner supply and return connections. Do not use sealers at the swivel flare connections of hoses.
4. Trisodium phosphate was formerly recommended as a cleaning agent during flushing. However, many states and localities ban the introduction of phosphates into their sewage systems. The current recommendation is to simply flush longer with warm 80°F (27°C) water.
5. Refill the system with clean water. Test the water using litmus paper for acidity, and treat as required to leave the water slightly alkaline (pH 7.5 to 8.5). The specified percentage of antifreeze may also be added at this time. Use commercial grade antifreeze designed for HVAC systems only. Do not use automotive grade antifreeze. Once the system has been filled with clean water and antifreeze (if used), precautions should be taken to protect the system from dirty water conditions. Dirty water will result in system wide degradation of performance and solids may clog valves, strainers, flow regulators, etc. Additionally, the heat exchanger may become clogged which reduces compressor service life or causes premature failure.
6. Set the loop water controller heat add setpoint to 70°F (21°C) and the heat rejection setpoint to 85°F (29°C). Supply power to all motors and start the circulating pumps. After full flow has been established through all components including the heat rejector (regardless of season) and air vented and loop temperatures stabilized, each of the conditioners will be ready for check, test and start-up, air balancing, and water balancing.

**Table 17: MicroTech III SmartSource unit controller terminals & descriptions**

H1 - 1	24	24 VAC Power Input
H1 - 2	C	24 VAC common
H2 - 1	SL1	Fan Main Required Output – Switched L1
H2 - 2		Blank Terminal
H2 - 3	N	Fan Main Required Output – Neutral
H3 - 1	HP1-1	Comp High Pressure Switch (HP1) Input Terminal 1
H3 - 2	HP1-2	Comp High Pressure Switch (HP1) Input Terminal 2
H4 - 1	1	Discharge Air Temp Sensor – Common
H4 - 2		Discharge Air Temp Sensor – Signal
H4 - 3		Leaving Water Temp Sensor – Common
H4 - 4		Leaving Water Temp Sensor – Signal
H5 - 1	1	Connections to I/O Expansion Board
H5 - 2		
H5 - 3		
H5 - 4		
H5 - 5		
H5 - 6		
H5 - 7		
H5 - 8		
H5 - 9		
H5 - 10		
H5 - 11		
H5 - 12		
H6 - 1	1	Condensate Overflow Signal Input
H6 - 2		Compressor Suction Temp Sensor (LT1) – Common
H6 - 3		Compressor Suction Temp Sensor (LT1) – Signal
H6 - 4		Compressor Low Pressure Switch (LP1) – Source Voltage
H6 - 5		Compressor Low Pressure Switch (LP1) – Signal
H6 - 6		Reversing Valve – Common
H6 - 7		Reversing Valve – Output
H7 - 1	1	No Connection
H7 - 2		No Connection
H7 - 3		Red LED Output
H7 - 4		Green LED Output
H7 - 5		Yellow LED Output
H7 - 6		Red-Green-Yellow LED Common
H8 - 1	1	Isolation Valve/Pump Request Relay N/O
H8 - 2		Isolation Valve/Pump Request Relay N/C
H8 - 3		24 VAC Common
H9 - 1	1	Return Air Sensor – Signal
H9 - 2		Return Air Sensor – Common
TB1 - 1	1	Room Sensor – Status LED Output
TB1 - 2	2	Room Sensor – Fan Mode & Unit Mode Switches
TB1 - 3	3	Room Sensor – Setpoint Adjust Potentiometer
TB1 - 4	4	Room Sensor – Room Temp Sensor & Tenant Override
TB1 - 5	5	Room Sensor – DC Signal Common
TB2 - 1	R	24 VAC
TB2 - 2	A	Thermostat – Alarm Output
TB2 - 3	W2	Thermostat – Heat Stage #2 (W2) Input
TB2 - 4	W1	Thermostat – Heat Stage #1 (W1) Input
TB2 - 5	Y2	Thermostat – Cool Stage #2 (Y2) Input
TB2 - 6	Y1	Thermostat – Cool Stage #1 (Y1) Input
TB2 - 7	G	Thermostat – Fan Input

TB2 - 8	O	Thermostat – Heat Stage #3 (W3) Input
TB2 - 9	C	24 VAC Common
TB3 - 1	E	Emergency Shutdown Input
TB3 - 2	U	Unoccupied Input
L1 - 1	L1 - 1	Line Voltage Terminal 1
L1 - 2	L1 - 2	Line Voltage Terminal 2
L1 - 3	L1 - 3	Line Voltage Terminal 3
N1	N1	Neutral Terminal 1
N2	N2	Neutral Terminal 2
N3	N3	Neutral Terminal 3

**I/O expansion module connectors/terminals**

H1 - 1	1	Connections to Main Board
H1 - 2		
H1 - 3		
H1 - 4		
H1 - 5		
H1 - 6		
H1 - 7		
H1 - 8		
H1 - 9		
H1 - 10		
H1 - 11		
H1 - 12		
H2 - 1	1	Auxiliary Heat Stage #2 Output – N/O
H2 - 2		No Connection
H2 - 3		24 VAC Common
H3 - 1	1	Ext. 24 VAC In
H3 - 2		Ext. 24 VAC Common In
H3 - 3		HGR / Waterside Economizer Output – N/O
H3 - 4		Ext. 24 VAC Common
H3 - 5		ECM Fan Motor Variable Speed Signal Output
H3 - 6		ECM Fan Motor Variable Speed Signal – Common
H4 - 1	1	Entering Water Temp Sensor – Signal
H4 - 2		Entering Water Temp Sensor – Common
H5 - 1	1	No Connection
H5 - 2		No Connection
H5 - 3		Red LED Output
H5 - 4		Green LED Output
H5 - 5		Yellow LED Output
H5 - 6		Red-Green-Yellow LED Common
H6 - 1	HP2-1	Jumper Wire Connection
H6 - 2	HP2-2	Jumper Wire Connection
H7 - 1		Fan Speed Table Row Select – Signal
H7 - 2		Fan Speed Table Row Select – Common
H7 - 3		Thermostat – Heat Stage #4 (W4) Input – Signal
H7 - 4		Auxiliary 24 VAC Out
H8 - 1	1	Compressor – High Capacity Output – N/O
H8 - 2		24 VAC Common
H8 - 3		No Connection
H8 - 4		Auxiliary Heat Stage #1 / Hydronic Heat Output N/O (24 VAC)
H8 - 5		24 VAC Common
TB1 - 1	1	Humidistat Signal Input
TB1 - 2	2	Thermostat - Heat Stage #4 (W4) Input – Signal

Figure 34: MicroTech SmartSource unit controller & I/O expansion module

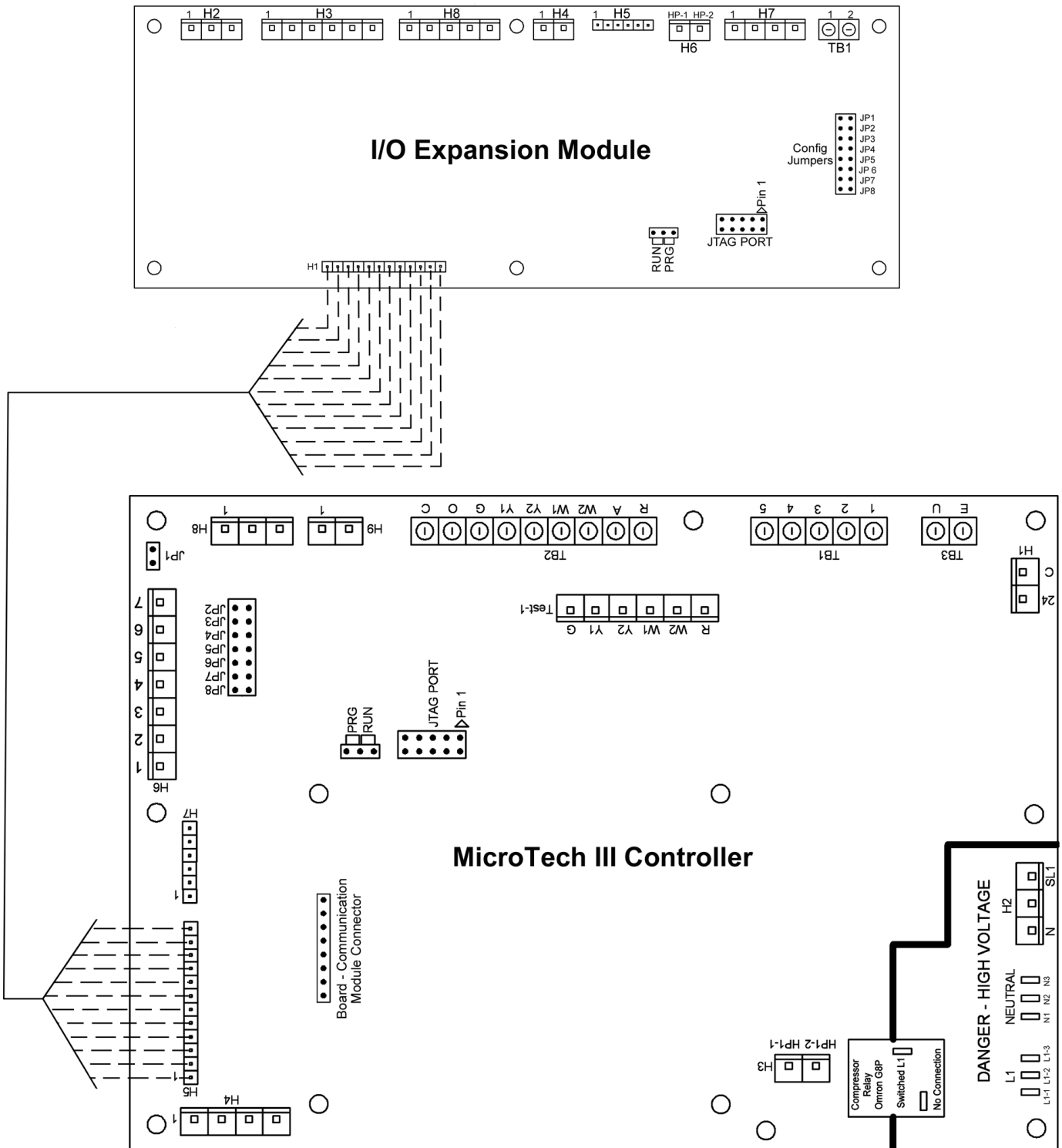

Note: Refer to Table 17 on page 30 for terminal descriptions

# Jumper Configuration Settings

Figure 35: Configuration jumpers location

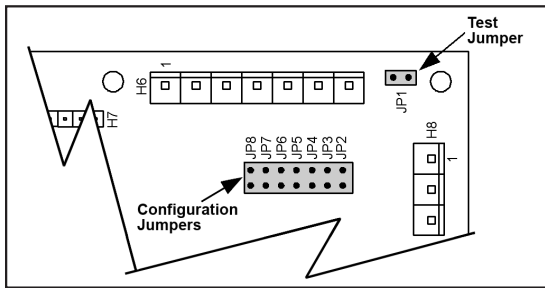

## WARNING

Proper antifreeze/water solution is required to minimize the potential of fluid freeze-up. Jumper JP3 is factory set for water freeze protection with the jumper open. Operation at fluid temperatures below 32°F with anti-freeze protection requires JP3 to be field configured for the jumper closed. If unit is employing a fresh water system (no anti-freeze protection), it is extremely important that JP3 jumper setting remains in the open position (factory default setting) in order to shut down the unit at the appropriate water temperature to protect your heat pump from freezing. Failure to do so can result in unit damage, property damage and will void unit warranty.

Table 18: Jumper settings and descriptions

Jumper	Description	Options
JP1	Mode	Open for normal operation mode
		Shorted for service/test operation mode
JP2	Fan operation	Open for continuous fan operation, when not in unoccupied mode.
		Shorted for cycling fan operation
JP3 (See Warning)	Freeze Protection	Open for water freeze protection
		Shorted for systems with anti-freeze protection (15°F (9°C))
JP4	Freeze Fault Protection	Open for none
		Shorted to enable freeze fault protection based on Leaving Water Temperature (LWT)
JP5	Set point adjustment range only applies to network controls with a room temperature sensor	Open for adjustment range of -5.0° to +5.0° F
		Shorted for 55° to 95° F adjustment range
JP6	Room control type	Open for thermostatic room control
		Shorted for room temperature sensor control, MicroTech III only.
JP7	Compressor heating source	Open to enable compressor heating
		Shorted to disable compressor heating
JP8	I/O expansion module	Open when I/O expansion module is not needed
		Shorted when I/O expansion module is required

Table 19: I/O expansion module jumper settings

I/O Expansion Description	Jumper(s)	Setting	Model
Fan Row Select for Operating Modes: • Fan Only • Hydronic Heating • Waterside Economizer	JP1 & JP2	JP1 = Open JP2 = Open	Fan Row #1 Selected
		JP1 = Shorted JP2 = Open	Fan Row #2 Selected
		JP1 = Open JP2 = Shorted	Fan Row #3 Selected
		JP1 = Shorted JP2 = Shorted	Fan Row #4 Selected
Secondary Heating Options	JP3 & JP4	JP3 = Open JP4 = Open	None
		JP3 = Shorted JP4 = Open	Supplemental Electric Heat
		JP3 = Open JP4 = Shorted	Boilerless Electric Heat
		JP3 = Shorted JP4 = Shorted	Hydronic Heat
Dehumidification Options / Waterside Economizer	JP5 & JP6	JP5 = Open JP6 = Open	None
		JP5 = Shorted JP6 = Open	Hot Gas/Water Reheat (HGR)
		JP5 = Open JP6 = Shorted	Waterside Economizer
Not Used	JP7	JP7 = Open	-
Compressor Capacity Option	JP8	JP8 = Open JP8 = Shorted	Single-Stage Capacity Dual-Stage Capacity

## MicroTech® III SmartSource Unit Controller

The MicroTech III SmartSource unit controller allows thermostat, Daikin sensor and DDC standalone operation. The R (24VAC) terminal is used to operate thermostat inputs G, Y1, Y2, W1, W2, W3, W4 and TB1-1. The C (0VAC) terminal is used to control inputs U, E and O. No external power sources may be used to operate the MicroTech III controller. All units must be properly grounded per local code requirements.

### NOTICE

For information on sequence of operation and troubleshooting refer to OM 1149-xx.

### Remote Reset of Automatic Lockouts

The Remote Reset feature provides the means to remotely reset automatic lockouts. There are (3) means to reset an automatic lockout condition:

- Using the thermostat create 2 demands for capacity within 30 seconds
- Press the Room Sensor or Thermostat Timed Override/Reset Button for more than 10 seconds
- Turn the unit power off

When the cause of the fault condition has been cleared, and the unit transitions from not requiring any capacity to needing any capacity twice within 30 seconds (accomplished by user manipulation of the Heat/Cool/Auto/Off switch on the thermostat), an alarm reset equivalent to a tenant override button reset is generated. The intelligent reset counter and the 24 hour timer are cleared when this type of alarm reset is generated.

**Note:** *This feature only applies to thermostat controlled systems.*

For room sensor controlled units, pressing the “Override” or “Reset” button for more than 10 seconds will apply a ground signal to the tenant override in(screw terminal connection at TB1 pin 4) will clear the lockout alarm once the cause of the fault condition has been cleared.

A unit power cycle can also be used to clear an automatic lockout if the conditions causing the fault have been cleared.

**Table 20: MicroTech III SmartSource unit controller fault & status LED's**

Description	Type	Yellow	Green	Red
I/O Expansion Communication Fail	Fault	ON	Flash	Flash
Invalid Configuration	Fault	Flash	Flash	OFF
Low Voltage Brownout	Fault	OFF	Flash	OFF
Emergency Shutdown	Mode	OFF	Flash	OFF
Compressor High Pressure	Fault	OFF	OFF	Flash
Compressor Low Pressure	Fault	OFF	OFF	ON
Compressor Suction Temp Sensor Fail	Fault	Flash	Flash	ON
Compressor Low Suction Temp	Fault	Flash	OFF	OFF
Freeze Fault Detect	Fault	Flash	OFF	Flash
Room Temp Sensor Fail (Room Sensor Control Only)	Fault	Flash	Flash	ON
Leaving Water Temp Sensor Fail	Fault	Flash	Flash	ON
Condensate Overflow	Fault	ON	OFF	OFF
Serial EEPROM Corrupted	Fault	ON	ON	ON
Waterside Economizer Low Temp Cutout (WSE Control & Call for Cooling)	Mode	Flash	ON	Flash
Service Test Mode Enabled	Mode	Flash	Flash	Flash
Unoccupied Mode	Mode	ON	ON	OFF
Occupied, Bypass, Standby, or Tenant Override Modes	Mode	OFF	ON	OFF

**Note:** *Mode/faults are listed in order of priority.*

**Table 21: I/O expansion module fault & status LED's**

Description	Type	Yellow	Green	Red
Baseboard Communication Fail	Fault	Flash	OFF	Flash
Entering Water Temp Sensor Fail (Boilerless Electric Heat or Waterside Economizer Only or Hydronic Heat)	Fault	ON	OFF	Flash
Low Entering Water Temperature (No Display On Boilerless Electric Heat)	Fault	OFF	ON	Flash
Fan is OFF	Mode	OFF	ON	OFF
Fan Running at Low Speed (0 to 33%) Duty Cycle	Mode	OFF	Flash	OFF
Fan Running at Medium Speed (34 to 66%) Duty Cycle	Mode	ON	Flash	OFF
Fan Running at High Speed (67 to 100%) Duty Cycle	Mode	Flash	Flash	OFF

**Table 22: Fault recovery and reset**

Fault Description	Auto Recovery	Tenant Override Button Reset	Network Reset
I/O Expansion Communication Fail	Yes	No	No
Invalid Configuration	No	No	No
Low Voltage Brownout	Yes	No	Yes
All Sensor Failures	No	No	Yes
Compressor High Pressure	No	Yes	Yes
Compressor Low Pressure	No	Yes	Yes
Compressor Low Suction Temp or Freeze Fault Detect (Heating and Cooling Modes)	Yes <sup>1</sup>	Yes	Yes
Compressor Low Suction Temp or Freeze Fault Detect (Dehumidification Mode)	Yes	Yes	Yes
Condensate Overflow	Yes	No	Yes
Low Entering Water Temp	Yes	No	No
Serial EEPROM Corrupted	No	No	No
Waterside Economizer Low Temp Cutout	Yes	No	No

**Note:** <sup>1</sup> Indicates auto recover is subject to intelligent alarm reset. Alarm auto recovers on first two occurrences, locked out on third within 24 hour period. See "Intelligent Alarm Reset" on page 32 for further details.

## MicroTech SmartSource Controller with LONWORKS® Communication Module

For installation and operation information on LONWORKS Communication Module and other ancillary control components, see:

- IM 927 - MicroTech III Water Source Heat Pump LONWORKS Communication Module
- IM 933 - LonMaker Integration Plug-in Tool: For use with the MicroTech III SmartSource Unit Controller
- IM 955 - MicroTech III Wall Sensor for use with MicroTech III SmartSource Unit Controller

**Figure 36: LONWORKS communication module**



## MicroTech SmartSource Controller with BACnet® Communication Module

For installation and operation information on MicroTech III SmartSource unit controller and other ancillary components, see:

- IM 928 - MicroTech III BACnet Communication Module
- OM 931 - MicroTech III SmartSource Unit Controller for Water Source Heat Pumps Operation and Maintenance Manual
- IM 955 - MicroTech III Wall Sensor For use with MicroTech III SmartSource Unit Controller

**Figure 37: MicroTech III BACnet water source heat pump snap-in communication module**

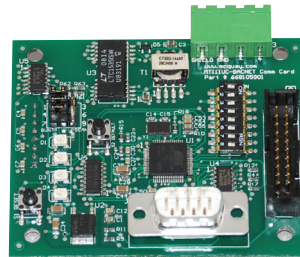

# Constant Torque EC Motor

Table 23: Constant torque EC motor CFM values

Unit Size	Setting	Function	External Static Pressure (inches of water column)												
			.10	.15	.20	.25	.30	.35	.40	.45	.50	.55	.60	.65	.70
007	Setting 4 (High)	Stage 1	368	352	336	320	304	288	272	256	240	224	206	188	180
	Setting 3 (Standard)		341	324	306	289	271	253	235	217	198	180	162	145	
	Setting 2 (Medium)		312	294	275	256	236	216	195	174	152				
	Setting 1 (Low)		312	294	275	256	236	216	195	174	152				
	Setting 4 (High)	Stage 2	394	378	363	348	333	319	304	290	276	262	244		
	Setting 3 (Standard)		368	352	336	320	304	288	272	256	240				
	Setting 2 (Medium)		341	324	306	289	271	253	235	217	198			165	
	Setting 1 (Low)		312	294	275	256	236	216	195	174	152				
	A	Fan Only, Hydronic Heat and WSE	368	352	336	320	304	288	272	256	240				
	B		341	324	306	289	271	253	235	217	198				
	C		312	294	275	256	236	216	195	174	152				
	D		264	244	222	199	176	151	125	98					
009	Setting 4 (High)	Stage 1	408	393	378	364	349	335	321	308	294	281	264	246	
	Setting 3 (Standard)		372	356	340	324	308	292	276	261	245	229			
	Setting 2 (Medium)		337	320	302	284	266	248	230	211					
	Setting 1 (Low)		337	320	302	284	266	248	230	211					
	Setting 4 (High)	Stage 2	437	423	409	395	382	368	355	342	330	317	301	285	
	Setting 3 (Standard)		408	393	378	364	349	335	321	308	294	281	264	246	
	Setting 2 (Medium)		372	356	340	324	308	292	276	261	245	229			
	Setting 1 (Low)		337	320	302	284	266	248	230	211					
	A	Fan Only, Hydronic Heat and WSE	408	393	378	364	349	335	321	308	294				
	B		372	356	340	324	308	292	276	261	245				
	C		337	320	302	284	266	248	230	211					
	D		274	254	232	210	187	163	139	113					
012	Setting 4 (High)	Stage 1	459	445	431	417	404	390	377	364	351	339	324	309	294
	Setting 3 (Standard)		428	413	399	385	371	358	345	331	319	306	290		
	Setting 2 (Medium)		394	378	363	348	333	319	304	290					
	Setting 1 (Low)		394	378	363	348	333	319	304	290					
	Setting 4 (High)	Stage 2	486	473	459	445	431	417	402	388	374	359	348	337	326
	Setting 3 (Standard)		459	445	431	417	404	390	377	364	351	339	324	309	294
	Setting 2 (Medium)		428	413	399	385	371	358	345	331	319	306	290		
	Setting 1 (Low)		394	378	363	348	333	319	304	290					
	A	Fan Only, Hydronic Heat and WSE	459	445	431	417	404	390	377	364	351	339	324	309	
	B		428	413	399	385	371	358	345	331	319	306	290	265	
	C		394	378	363	348	333	319	304	290	278	264	250		
	D		337	319	302	284	266	248	229	210	192	172	153		

Note: Gray tinted areas, outside recommended operating range.



## Constant CFM Type EC Motor Fan Settings

**Table 24: Single stage units with constant CFM type EC motor**

Unit Size	Setting	Maximum ESP (in. wg.) <sup>2</sup>	<sup>1</sup> Low CFM Heat	<sup>1</sup> High CFM Heat	<sup>1</sup> Low CFM Cool	<sup>1</sup> High CFM Cool	Fan Only	Dehumidification	Electric Heat
015	Setting 4 (High)	.70	500	560	500	560	375	375	560
	Setting 3 (Standard)	.70	440	500	440	500	375	375	560
	Setting 2 (Medium)	.70	375	440	375	440	280	375	560
	Setting 1 (Low)	.70	375	375	375	375	280	375	560
019	Setting 4 (High)	.70	600	675	600	675	450	450	675
	Setting 3 (Standard)	.70	525	600	525	600	450	450	675
	Setting 2 (Medium)	.70	450	525	450	525	340	450	675
	Setting 1 (Low)	.70	450	450	450	450	340	450	675
024/026	Setting 4 (High)	.70	800	900	800	900	600	600	900
	Setting 3 (Standard)	.70	700	800	700	800	600	600	900
	Setting 2 (Medium)	.70	600	700	600	700	450	600	900
	Setting 1 (Low)	.70	600	600	600	600	450	600	900
030/032	Setting 4 (High)	.70	1000	1125	1000	1125	750	750	1125
	Setting 3 (Standard)	.70	875	1000	875	1000	750	750	1125
	Setting 2 (Medium)	.70	750	875	750	875	560	750	1125
	Setting 1 (Low)	.70	750	750	750	750	560	750	1125
036/038	Setting 4 (High)	.70	1250	1400	1250	1400	940	938	1400
	Setting 3 (Standard)	.70	1090	1250	1090	1250	940	938	1400
	Setting 2 (Medium)	.70	940	1090	940	1090	700	938	1400
	Setting 1 (Low)	.70	940	940	940	940	700	938	1400
042/044	Setting 4 (High)	.70	1400	1575	1400	1575	1050	1050	1575
	Setting 3 (Standard)	.70	1225	1400	1225	1400	1050	1050	1575
	Setting 2 (Medium)	.70	1050	1225	1050	1225	785	1050	1575
	Setting 1 (Low)	.70	1050	1050	1050	1050	785	1050	1575
048/049	Setting 4 (High)	.70	1600	1800	1600	1800	1200	1200	1800
	Setting 3 (Standard)	.70	1400	1600	1400	1600	1200	1200	1800
	Setting 2 (Medium)	.70	1200	1400	1200	1400	900	1200	1800
	Setting 1 (Low)	.70	1200	1200	1200	1200	900	1200	1800
060/064	Setting 4 (High)	.70	2000	2250	2000	2250	1500	1500	2250
	Setting 3 (Standard)	.70	1750	2000	1750	2000	1500	1500	2250
	Setting 2 (Medium)	.70	1500	1750	1500	1750	1120	1500	2250
	Setting 1 (Low)	.70	1500	1500	1500	1500	1120	1500	2250
070/072	Setting 4 (High)	.70	2160	2400	2160	2400	1710	1710	2400
	Setting 3 (Standard)	.70	1920	2160	1920	2160	1710	1710	2400
	Setting 2 (Medium)	.70	1710	1920	1710	1920	1330	1710	2400
	Setting 1 (Low)	.70	1710	1710	1710	1710	1330	1710	2400

**Notes:** 1. The unit is capable of high-low fan performance through the use of a 2-stage thermostat wired to specific terminals for High-Low CFM fan performance. Standard operation with a 1-stage thermostat is indicated as High CFM fan performance.

2. Applications up to 1.0" ESP (in. wg.) are possible. However, increased fan noise should be anticipated and appropriate noise attenuation should be considered.



## Fan Performance For Constant CFM EC Motor (Sizes 015–072)

**Table 25: Fan settings and performance**

Unit Size	Setting	Fan Only	Hydronic Heat	Waterside Economizer
015	A	500	500	500
	B	440	440	440
	C	375	375	375
	D	280	280	375
019	A	600	600	600
	B	525	525	525
	C	450	450	450
	D	340	340	450
024/026	A	800	800	800
	B	700	700	700
	C	600	600	600
	D	450	450	600
030/032	A	1000	1000	1000
	B	875	875	875
	C	750	750	750
	D	560	560	750
036/038	A	1250	1250	1250
	B	1090	1090	1090
	C	940	940	940
	D	700	700	940
042/044	A	1400	1400	1400
	B	1225	1225	1225
	C	1050	1050	1050
	D	785	785	785
048/049	A	1600	1600	1600
	B	1400	1400	1400
	C	1200	1200	1200
	D	900	900	1200
060/064	A	2000	2000	2000
	B	1750	1750	1750
	C	1500	1500	1500
	D	1120	1120	1500
070/072	A	2160	2160	2160
	B	1920	1920	1920
	C	1710	1710	1710
	D	1330	1330	1710

**Table 26: I/O expansion module jumper configuration**

I/O Expansion board configuration		
Setting	JP1	JP2
<b>A</b>	Open	Open
<b>B</b>	Shorted	Open
<b>C</b>	Open	Shorted
<b>D</b>	Shorted	Shorted

**Figure 38: JP1 & JP2 location on the I/O expansion module**

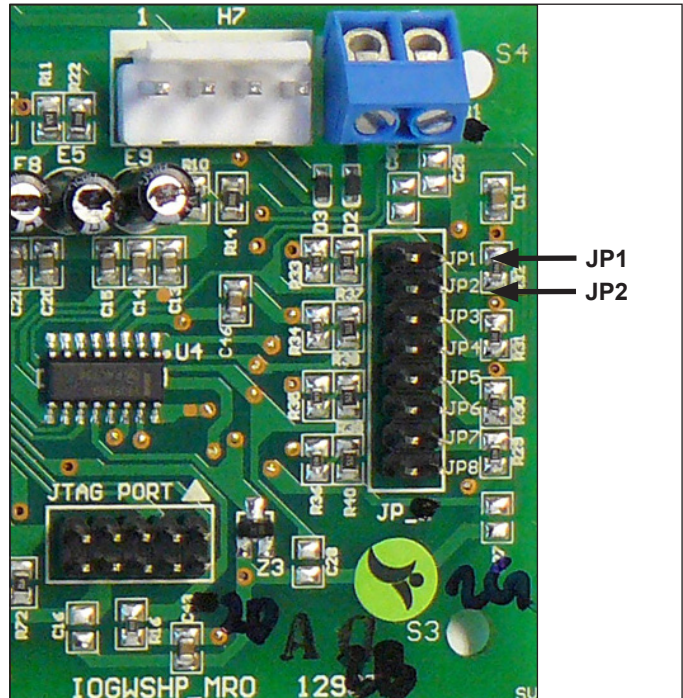

## Fan Speed Selector Switch

A 4-position fan speed selector switch located in the control box allows CFM settings to be field adjustable. Fan speed control optimizes unit fan speed based on thermostat/room sensor inputs. The fan speed switch allows for manually setting an optimal fan speed specific to the application requirements. Each position on the fan speed switch represents settings 1-4. See [Table 27](#) below for the complete list of fan speed selector switch settings.

Figure 39: 4-position fan speed selector switch

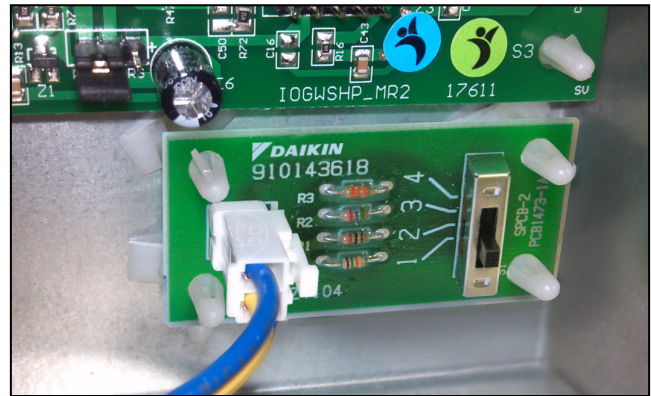

## Fan CFM Settings & Performance

Table 27: 2-Stage units with constant cfm type EC motor

Unit Size	Setting	Maximum ESP (in. wg.)	Part Load Stage 1 Heat	Full Load Stage 2 Heat	Part Load Stage 1 Cool	Full Load Stage 2 Cool	Fan Only	Dehumidification	Electric Heat
024, 026	Setting 4 (High)	.70	800	900	800	900	600	600	900
	Setting 3 (Standard)	.70	700	800	700	800	600	600	900
	Setting 2 (Medium)	.70	600	700	600	700	450	600	900
	Setting 1 (Low)	.70	600	600	600	600	450	600	900
030, 032	Setting 4 (High)	.70	1000	1125	1000	1125	750	750	1125
	Setting 3 (Standard)	.70	875	1000	875	1000	750	750	1125
	Setting 2 (Medium)	.70	750	875	750	875	560	750	1125
	Setting 1 (Low)	.70	750	750	750	750	560	750	1125
036, 038	Setting 4 (High)	.70	1250	1400	1250	1400	940	938	1400
	Setting 3 (Standard)	.70	1090	1250	1090	1250	940	938	1400
	Setting 2 (Medium)	.70	940	1090	940	1090	700	938	1400
	Setting 1 (Low)	.70	940	940	940	940	700	938	1400
042, 044	Setting 4 (High)	.70	1400	1575	1400	1575	1050	1050	1575
	Setting 3 (Standard)	.70	1225	1400	1225	1400	1050	1050	1575
	Setting 2 (Medium)	.70	1050	1225	1050	1225	785	1050	1575
	Setting 1 (Low)	.70	1050	1050	1050	1050	785	1050	1575
048, 049	Setting 4 (High)	.70	1600	1800	1600	1800	1200	1200	1800
	Setting 3 (Standard)	.70	1400	1600	1400	1600	1200	1200	1800
	Setting 2 (Medium)	.70	1200	1400	1200	1400	900	1200	1800
	Setting 1 (Low)	.70	1200	1200	1200	1200	900	1200	1800
060, 064	Setting 4 (High)	.70	2000	2250	2000	2250	1500	1500	2250
	Setting 3 (Standard)	.70	1750	2000	1750	2000	1500	1500	2250
	Setting 2 (Medium)	.70	1500	1750	1500	1750	1120	1500	2250
	Setting 1 (Low)	.70	1500	1500	1500	1500	1120	1500	2250
070, 072	Setting 4 (High)	.70	2400	2700	2160	2400	1800	1710	2400
	Setting 3 (Standard)	.70	2100	2400	1920	2160	1800	1710	2400
	Setting 2 (Medium)	.70	1800	2100	1710	1920	1340	1710	2400
	Setting 1 (Low)	.70	1800	1800	1710	1710	1340	1710	2400

Note: Applications up to 1.0" ESP (in. wg.) are possible. However, increased fan noise should be anticipated and appropriate noise attenuation should be considered.

## Information for Initial Start-up

### CAUTION

Units must be checked for water leaks upon initial water system start-up. Water leaks may be a result of mishandling or damage during shipping. Failure by the installing contractor to check for leaks upon start-up of the water system could result in property damage.

## Check, Test & Start Procedure

### NOTICE

Complete the "Water Source Heat Pump Equipment Check, Test and Start Form" on page 38.

### Check As Completed:

- Open all valves to full open position and turn on power to the unit.
- Set thermostat for "Fan Only" operation by selecting "Off" at the system switch and "On" at the fan switch. If "Auto" fan operation is selected, the fan will cycle with the compressor. Check for proper air delivery.
- Set thermostat to "Cool." If the thermostat is an automatic changeover type, simply set the cooling temperature to the coolest position. On manual changeover types additionally select "Cool" at the system switch.

Again, many units have time delays which protect the compressor(s) against short cycling. After a few minutes of operation, check the discharge grilles for cool air delivery. To insure proper water flow, measure the temperature difference between entering and leaving water. The temperature differential should be 10°F to 14°F (5°C to 8°C) for units in cooling mode. It should be approximately 1½ times greater than the heating mode temperature difference. For example, if the cooling temperature difference is 15°F (8°C), the heating temperature difference should have been 10°F (5°C).

Without automatic flow control valves, target a cooling temperature difference of 10°F to 14°F (5°C to 8°C). Adjust the combination shutoff/balancing valve in the return line to a water flow rate which will result in the 10°F to 14°F (5°C to 8°C) difference

- Set thermostat to "Heat." If the thermostat is the automatic changeover type, set system switch to the "Auto" position and depress the heat setting to the warmest selection. Some units have built-in time delays which prevent the compressor from immediately starting. With most control schemes, the fan will start immediately. After a few minutes of compressor operation, check for warm air delivery at discharge grille. If this is a "cold building" start-up, leave unit running until return air to the unit is at least 65°F (18°C).

Measure the temperature difference between entering and leaving air and entering and leaving water. With entering water of 60°F to 80°F (16°C to 27°C), leaving water should be 6°F to 12°F (3.3°C to 6.6°C) cooler, and the air temperature rise through the machine should not exceed 35°F (19°C). If the air temperature exceeds 35°F (19°C), then the water flow rate is inadequate.

- Check the elevation and cleanliness of the condensate line. If the air is too dry for sufficient dehumidification, slowly pour enough water into the condensate pan to ensure proper drainage.
- If the unit does not operate, check the following points:
  - a. Is supply voltage to the machine compatible?
  - b. Is thermostat type appropriate?
  - c. Is thermostat wiring correct?
- If the unit operates but stops after a brief period:
  - a. Is there proper airflow? Check for dirty filter, incorrect fan rotation (3-phase fan motors only), or incorrect ductwork.
  - b. Is there proper water flow rate within temperature limits? Check water balancing; back flush unit if dirt-clogged.
- Check for vibrating refrigerant piping, fan wheels, etc.

# MicroTech III Unit Control with BACnet Communication Module (HGRH) - 265-277V, 1-Phase

See service & disconnect portion of wiring diagram on page 48.

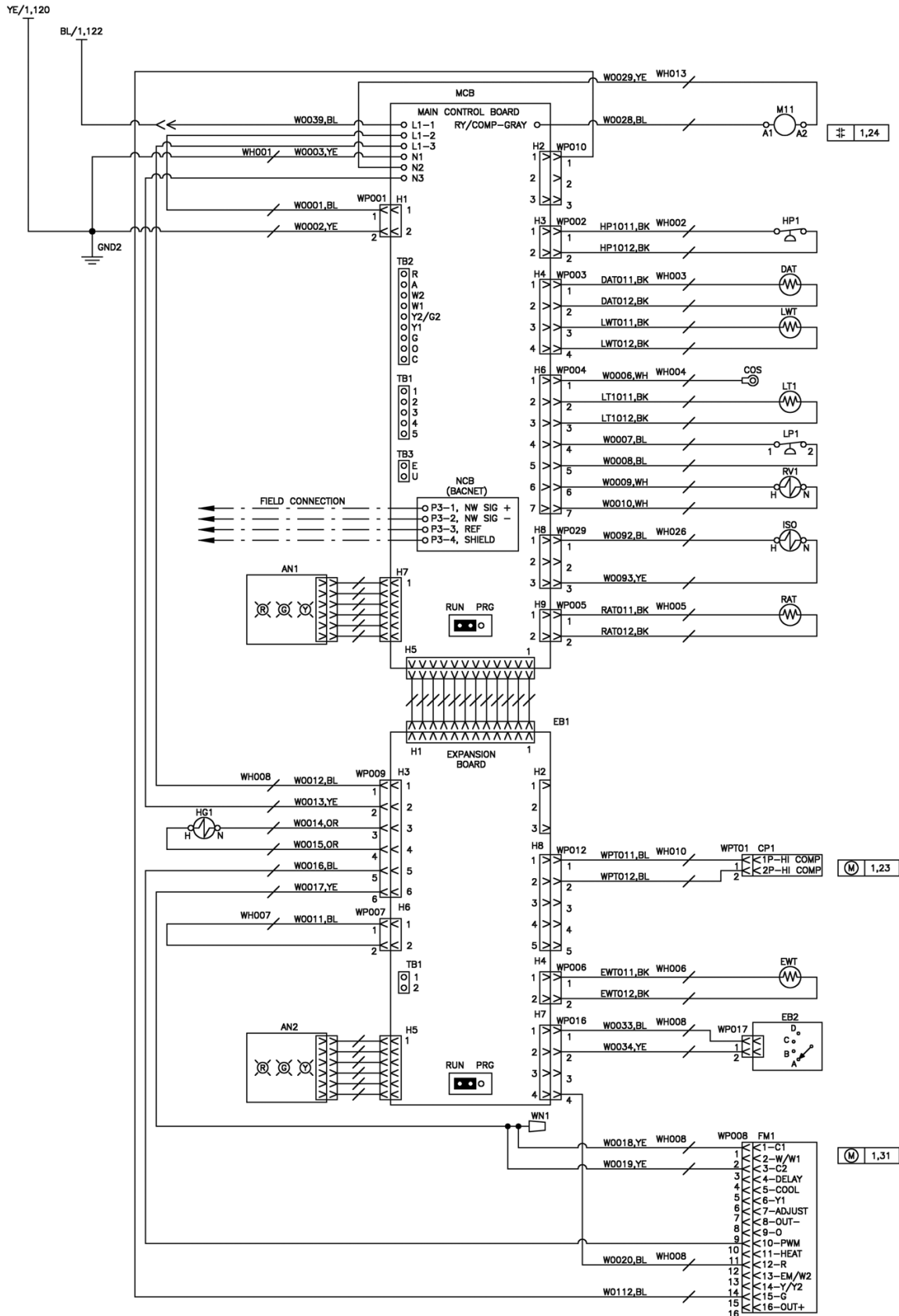

# MicroTech III Unit Control with BACnet Communication Module (WSE & DSH) - 208-230V, 1-Phase with 115V Loop Pumps and 20kW Electric Heat

See service & disconnect portion of wiring diagram on [page 49](#).

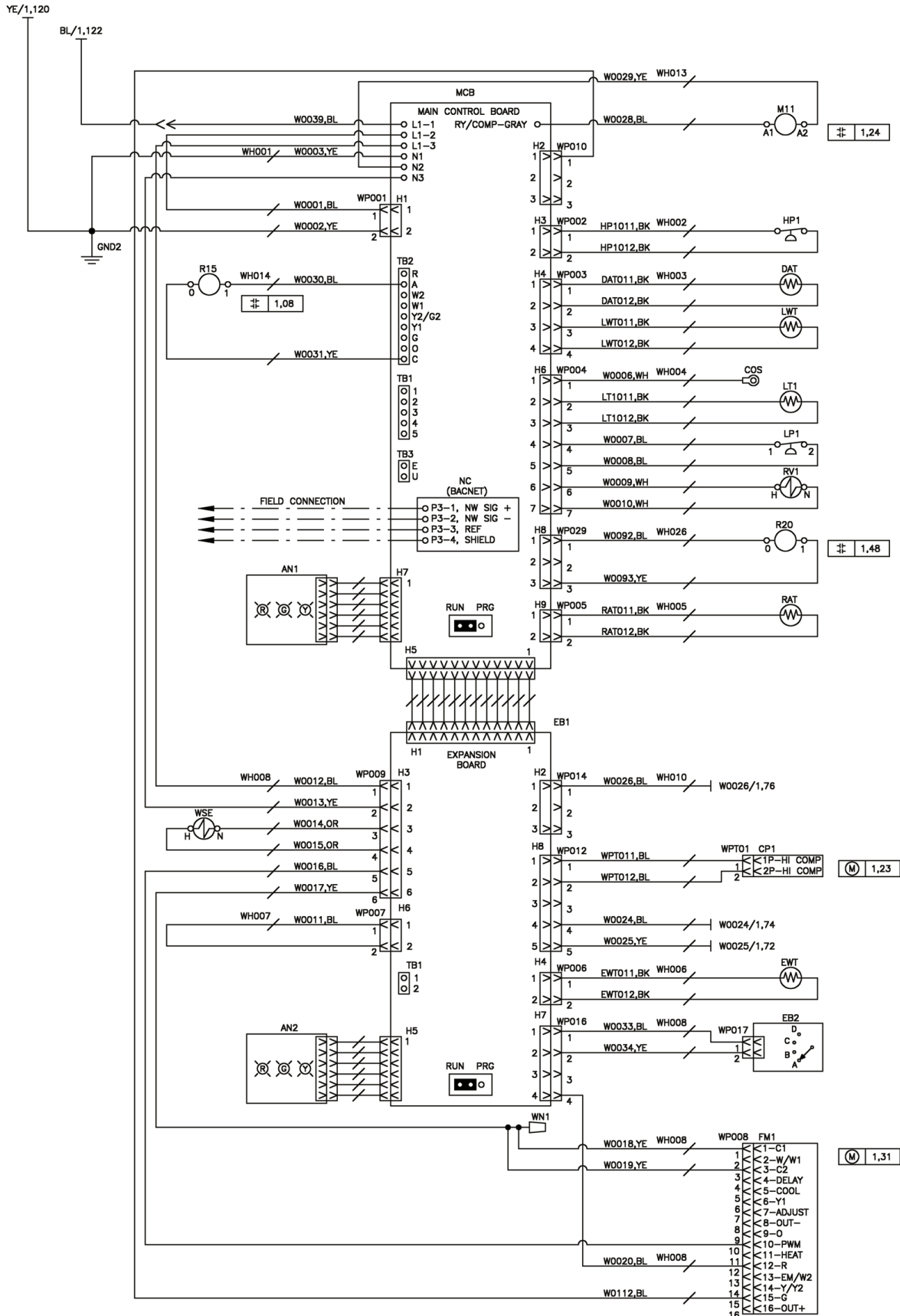



# MicroTech III Unit Control with LONWORKS Communication Module

## 208-230V, 3-Phase with 230V Loop Pumps and 5kW Electric Heat

See service & disconnect portion of wiring diagram on page 50.

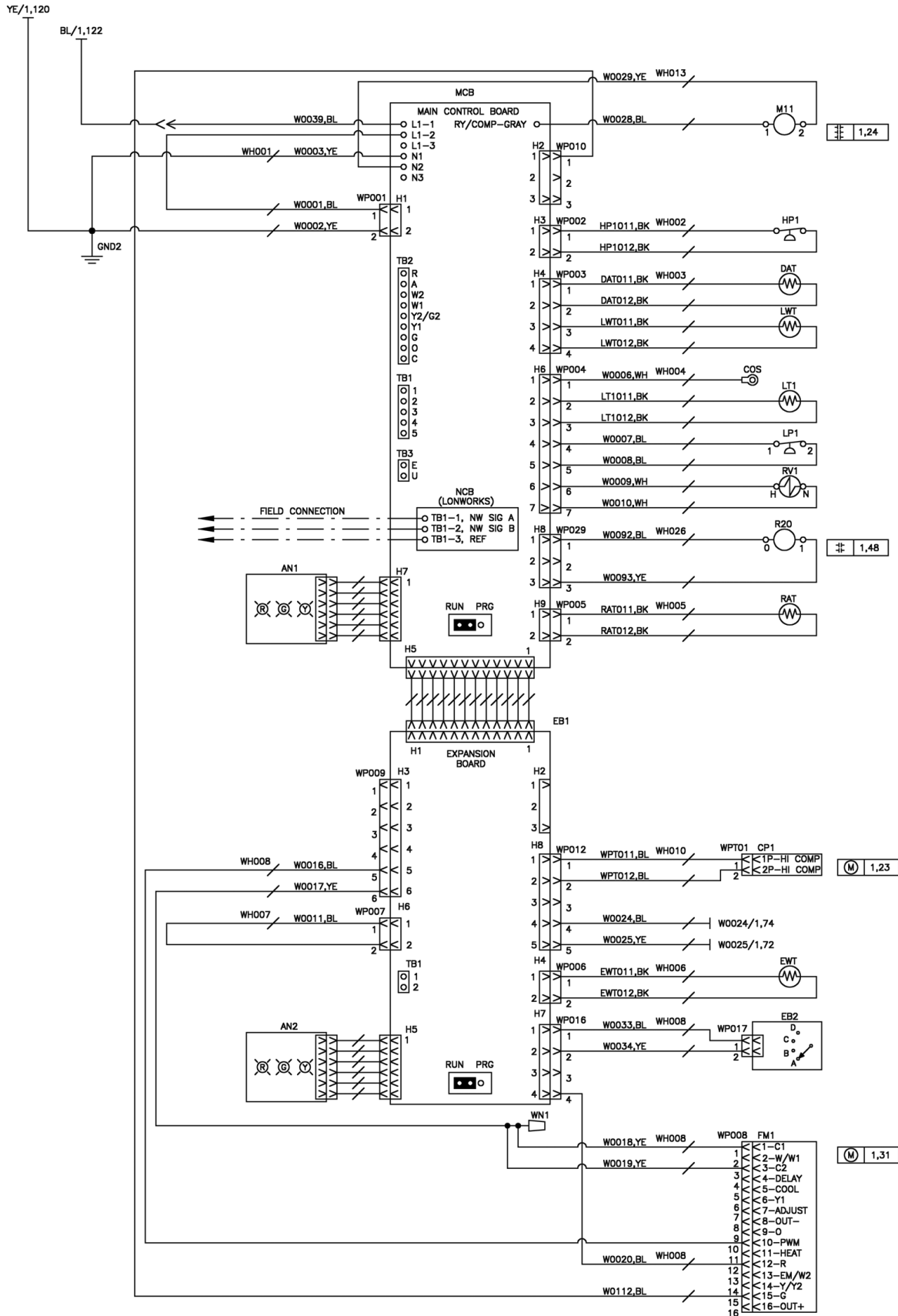



# MicroTech III Unit Control with BACnet Communication Module (WSE) 460V, 3-Phase with 230V Loop Pumps and 20kW Electric Heat

See service & disconnect portion of wiring diagram on page 51.

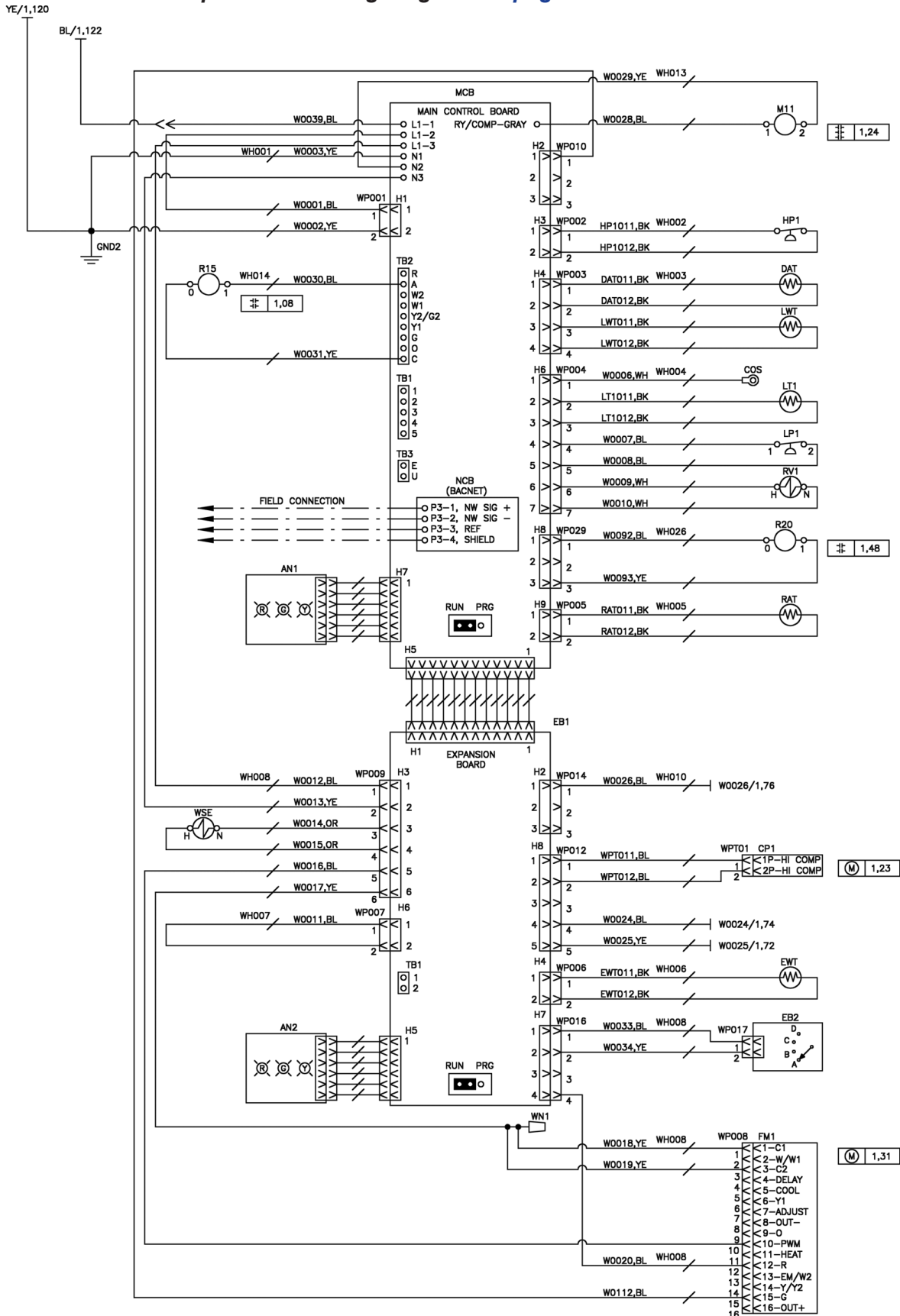

# MicroTech III Unit Control with Hydronic Heat (HYH) – 208-230V

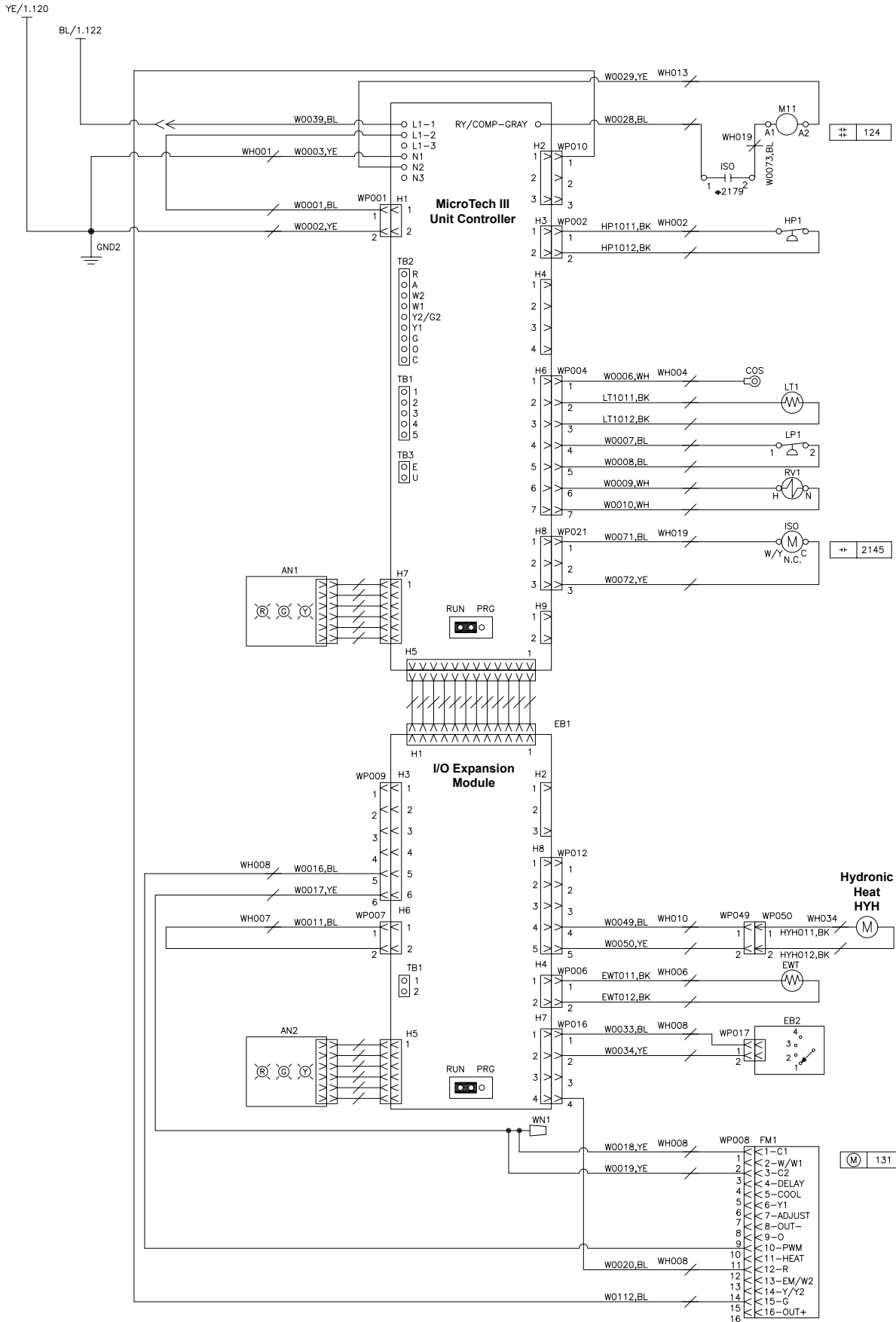

# Motor Removal

**Figure 40: Disassemble motor orifice ring & motor mount screws from fan housing**

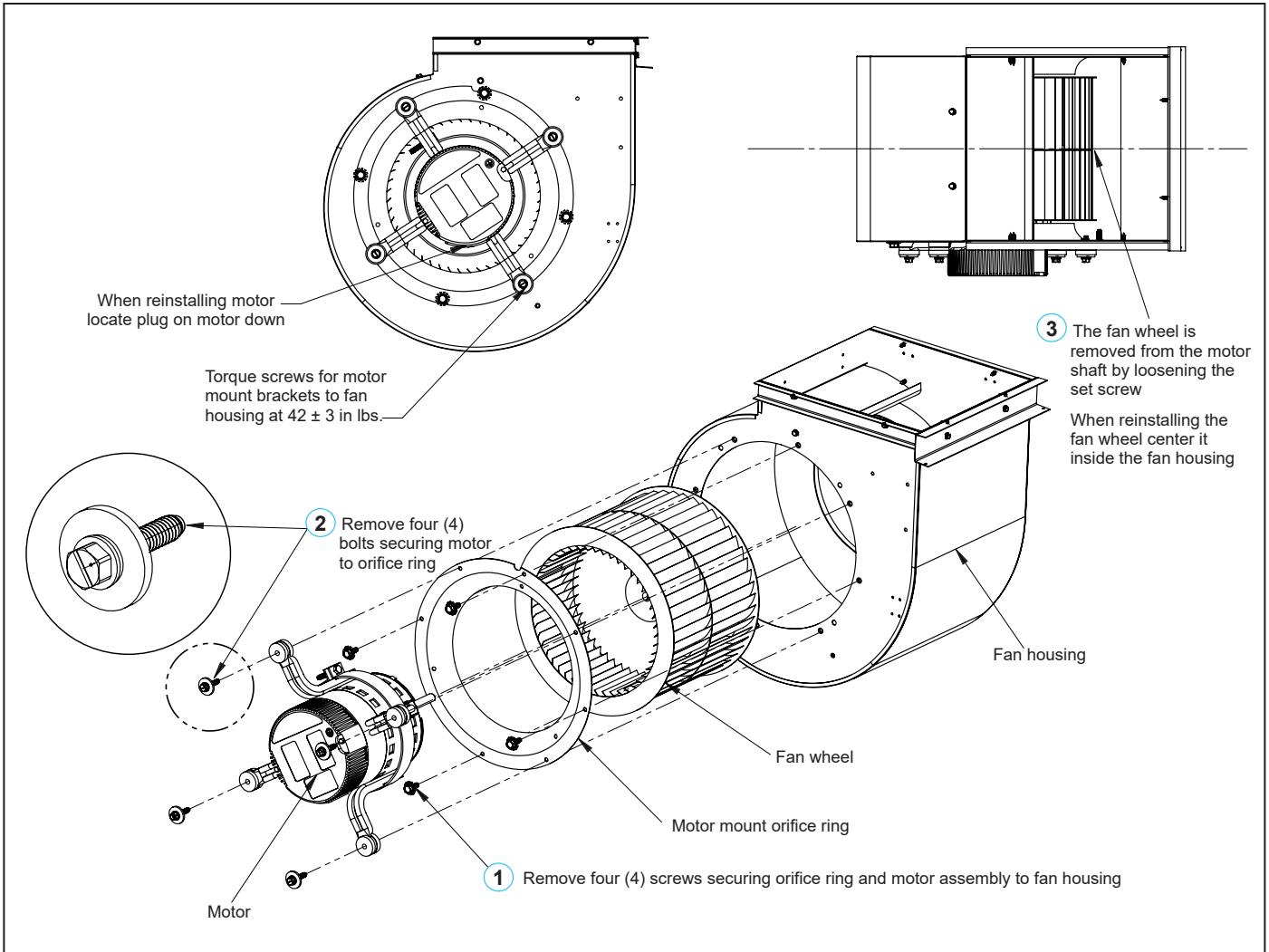

# Typical Refrigeration Cycles

Figure 41: Cooling mode

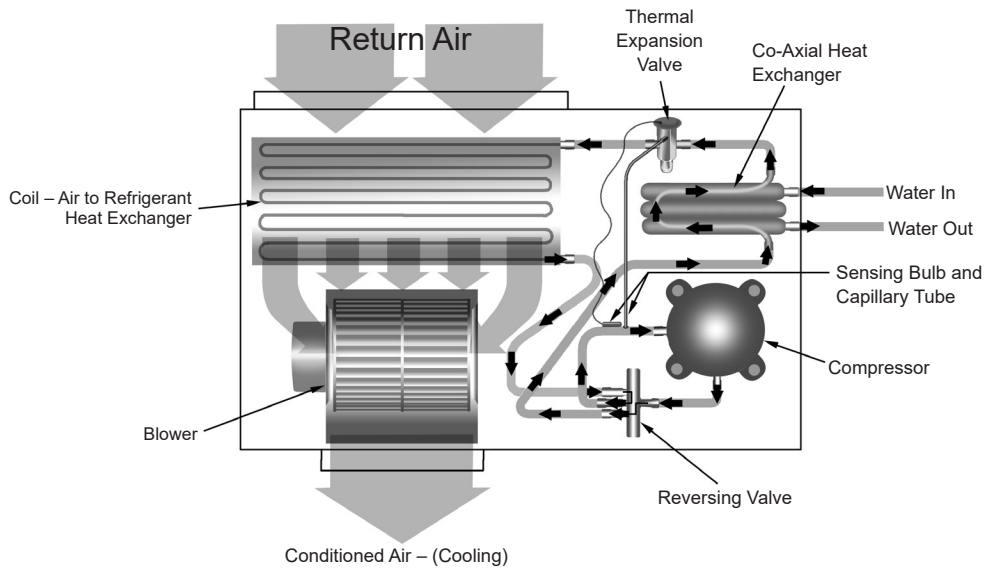

## Cooling Refrigeration Cycle

When the wall thermostat is calling for COOLING, the reversing valve is energized and directs the flow of the refrigerant (hot gas) leaving the compressor to the water-to-refrigerant heat exchanger. Here the heat is removed by the water and the hot gas condenses to become a liquid. The liquid then flows through a thermal expansion valve (TXV) and then to the air-to-refrigerant heat exchanger coil. The liquid then evaporates becoming a gas, at the same time absorbing heat and cooling the air passing over the surfaces of the coil. The refrigerant then flows as a low pressure gas through the reversing valve and back to the suction side of the compressor to complete the cycle.

Figure 42: Heating mode

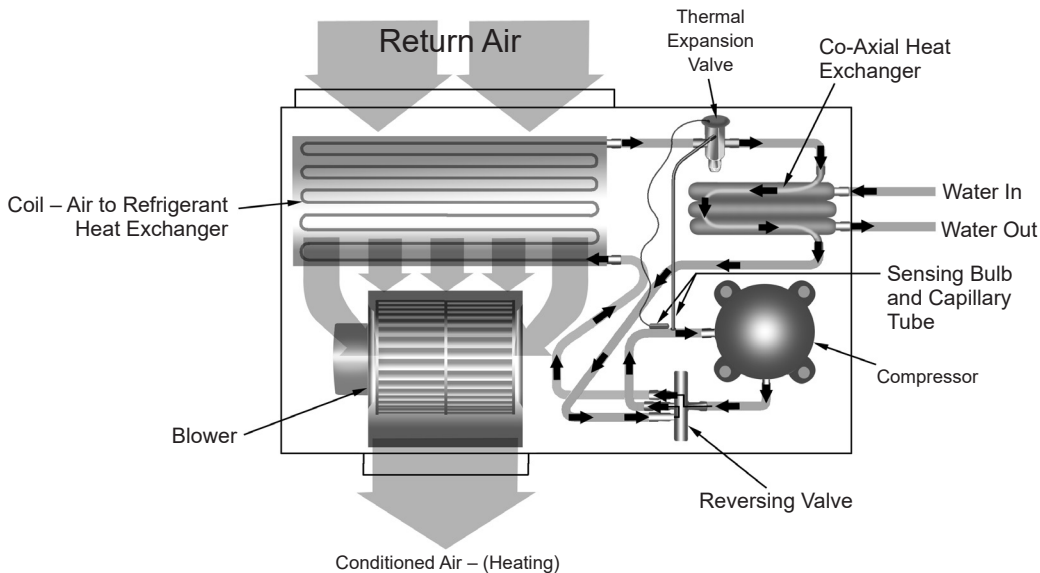

## Heating Refrigeration Cycle

When the wall thermostat is calling for HEATING, the reversing valve is energized and directs the flow of the refrigerant (hot gas) leaving the compressor to the air-to-refrigerant heat exchanger coil. Here the heat is removed by the air passing over the surfaces of the coil and the hot gas condenses to become a liquid. The liquid then flows through a thermal expansion valve (TXV) then to the water-to-refrigerant heat exchanger. The liquid then evaporates becoming a gas, at the same time absorbing heat and cooling the water. The refrigerant then flows as a low pressure gas through the reversing valve and back to the suction side of the compressor to complete the cycle.

## Environment

This equipment is designed for indoor installation only. Sheltered locations such as attics, garages, etc., generally will not provide sufficient protection against

extremes in temperature and/or humidity, and equipment performance, reliability, and service life may be adversely affected.

Table 28: Air limits in °F (°C)

Air Limits	Standard Range Units		Extended Range (Geothermal) Units	
	Cooling (DB/WB)	Heating	Cooling (DB/WB)	Heating
Minimum Ambient Air <sup>1</sup>	50°F (10°C)	50°F (10°C)	40°F (4°C)	40°F (4°C)
Maximum Ambient Air <sup>2</sup>	100°F/77°F (38°C/25°C)	85°F (29°C)	100°F/77°F (38°C/25°C)	85°F (29°C)
Minimum Entering Air <sup>1</sup>	65°F/55°F (18°C/13°C)	50°F (10°C)	65°F/55°F (18°C/13°C)	50°F (10°C)
Common Design Entering Air	75°F/63°F (24°C/17°C)	70°F (21°C)	75°F/63°F (24°C/17°C)	70°F (21°C)
Maximum Entering Air <sup>2</sup>	85°F/71°F (29°C/22°C)	80°F (27°C)	85°F/71°F (29°C/22°C)	80°F (27°C)

Table 29: Fluid limits

Fluid Limits	Standard Range Units		Extended Range (Geothermal) Units	
	Cooling	Heating	Cooling	Heating
Minimum Entering Fluid	55°F (13°C)	55°F (13°C)	30°F (-1°C)	20°F (-6°C)
Common Design Entering Fluid	85-90°F (29-32°C)	70°F (21°C)	90°F (32°C)	35-60°F (1.5-16°C)
Maximum Entering Fluid	120°F (43°C)	90°F (32°C)	120°F (43°C)	90°F (32°C)
Minimum GPM/Ton	1.5			
Nominal GPM/Ton	3.0			
Maximum GPM/Ton	4.0			

- Notes: 1. Maximum and minimum values may not be combined. If one value is at maximum or minimum, the other two conditions may not exceed the normal condition for standard units. Extended range units may combine any two maximum conditions, but not more than two, with all other conditions being normal conditions.
2. This is not a normal or continuous operating condition. It is assumed that such a start-up is for the purpose of bringing the building space up to occupancy temperature.

## Motorized Isolation Valve

The motorized valve kit is available as a factory-installed and wired option or may be ordered as a field-installed accessory.

Wired as shown in Figure 43, the motorized valve will open on a call for compressor operation.

The motorized isolation valve actuator (ISO) has both a 24V power connection and a 24V end switch connection.

Install the supplied wire harness into plug H8 on the main control board. Run wires between the ISO actuator and the supplied wire harness ends.

Connect N.O. & N.C. actuators as shown on the schematic. The end switch should be wired in series with the 24V compressor signal wire. Connect the end switch wires as shown in the schematic. The end switch will close when the valve is fully open.

**Note:** For detailed installation instructions for the field-installed motorized valve, refer to IM 1151.

Figure 43: Motorized valve wiring

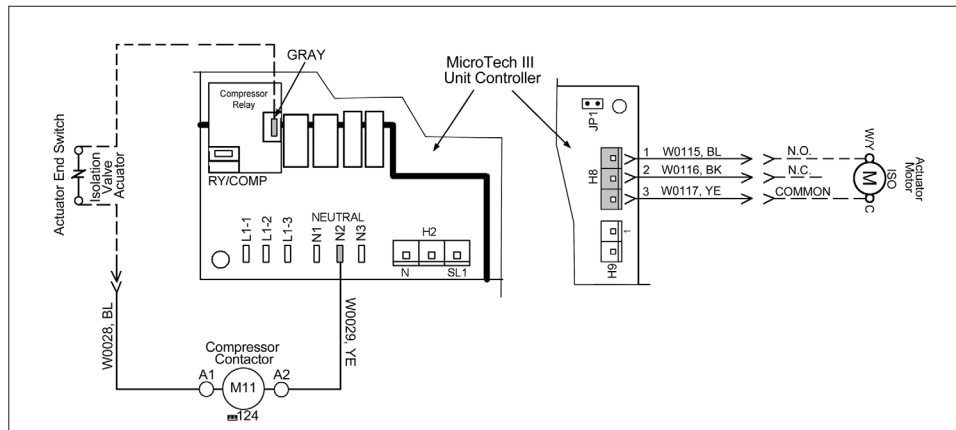

# MicroTech III Unit Control with BACnet Communication Module (HGRH)- 265-277V, 1-Phase, Service & Disconnect

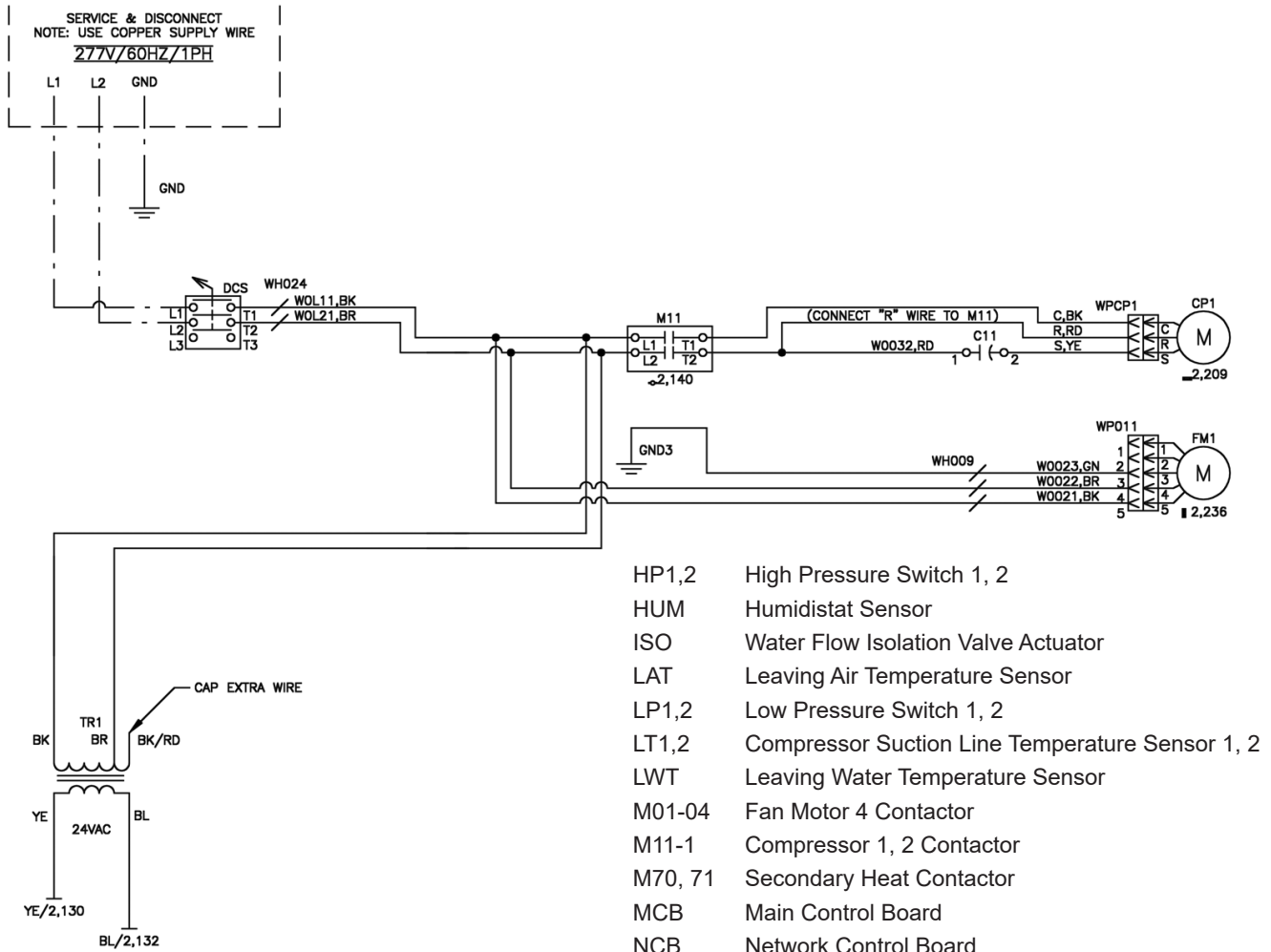

**Legend:**

**Note:** Devices in legend may or may not be on unit.

- |        |  |         |   |
|--------|--|---------|---|
| ADR    | Aquastat, Discharge Refrigerant            | HP1,2   | High Pressure Switch 1, 2                       |
| AHL    | Aquastat, High Limit                       | HUM     | Humidistat Sensor                               |
| AN1,2  | LED Annunicator, circuit 1, 2              | ISO     | Water Flow Isolation Valve Actuator             |
| CO1-04 | Fan Motor 1-4 Capacitor                    | LAT     | Leaving Air Temperature Sensor                  |
| C11-12 | Compressor 1,2 Capacitor                   | LP1,2   | Low Pressure Switch 1, 2                        |
| CP1,2  | Compressor 1, 2                            | LT1,2   | Compressor Suction Line Temperature Sensor 1, 2 |
| COS    | Condensate Overflow Protection Sensor      | LWT     | Leaving Water Temperature Sensor                |
| DAT    | Discharge Air Temperature Sensor           | M01-04  | Fan Motor 4 Contactor                           |
| DCS    | Disconnect Switch                          | M11-1   | Compressor 1, 2 Contactor                       |
| DSH    | Desuperheater Pump                         | M70, 71 | Secondary Heat Contactor                        |
| DSS    | Desuperheater Shutoff Switch               | MCB     | Main Control Board                              |
| EB1    | Expansion Control Board 1                  | NCB     | Network Control Board                           |
| EB2    | Expansion Control Board 2 - fan speed ctrl | OLP     | Overload Protector - Compressor Motor           |
| EH1    | Electric Heat                              | PL1,2   | Loop Pump 1, 2                                  |
| EWT    | Entering Water Temperature Sensor          | R15     | Relay, Field Contacts, Alarm Output             |
| FM1-4  | Fan Motor 1-4                              | R20     | Relay, Loop Pump                                |
| GND    | Ground                                     | RAT     | Return Air Temperature Sensor                   |
| HG1,2  | Hot Gas Reheat Valve Acuator               | RV1,2   | Reversing Valve 1, 2                            |
| HHT    | Hot Water Heat Valve Actuator              | TB1     | Terminal Block, Line Voltage                    |
|        |  | TB2     | Terminal Block, 24V                             |
|        |  | TB3     | Terminal Block, EH1 Line Voltage                |
|        |  | TR1     | Transformer - Control                           |
|        |  | TR2     | Transformer - Fan Motor                         |
|        |  | TR3     | Transformer - Loop Pump                         |
|        |  | TSL     | Thermostat, Wireless                            |
|        |  | TSW     | Thermostat, Wired (Unit-mounted)                |
|        |  | W0001-^ | Wire  |
|        |  | WH001-^ | Wire Harness                                    |
|        |  | WN1-^   | Wire Nut  |
|        |  | WP001-^ | Wire Plug                                       |
|        |  | WPCP1   | Wire Plug Assy - Compressor Power               |
|        |  | WPT01   | Wire Plug Assy - 2-stage Comp Ctrl              |
|        |  | WSE     | Waterside Economizer Actuator                   |





# MicroTech III Unit Control with LonWorks Communication Module Service & Disconnect 208-230V, 3-Phase with 230V Loop Pumps and 5kW Electric Heat

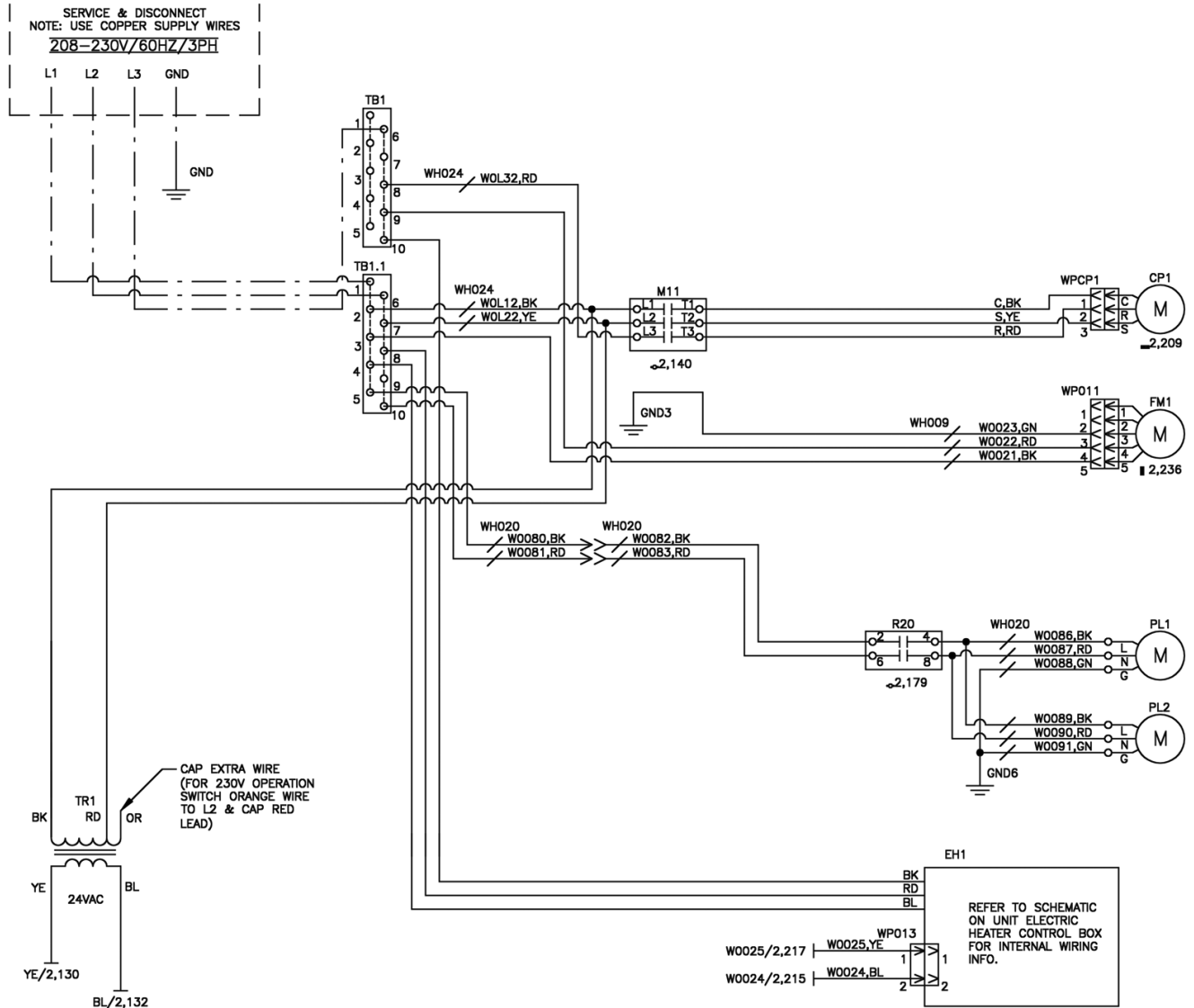

# MicroTech III Unit Control with BACnet Communication Module (WSE) Service & Disconnect - 460V, 3-Phase with 230V Loop Pumps and 20kW Electric Heat

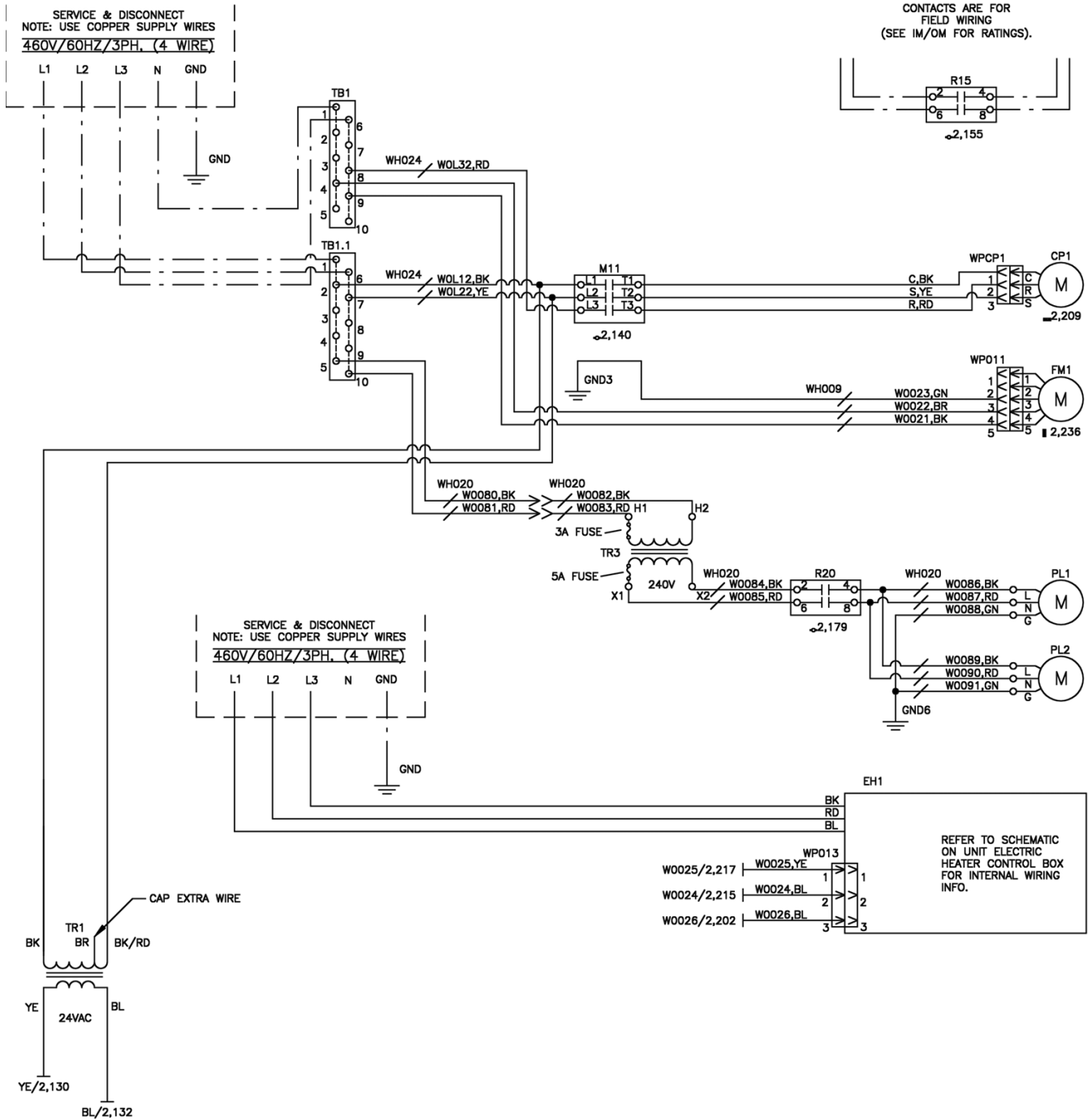

## General Maintenance

1. Normal maintenance on all units is generally limited to filter changes. Units are provided with permanently lubricated motors and require no oiling even though oil caps may be provided.
2. Filter changes are required at regular intervals. The time period between changes will depend upon the project requirements. Some applications such as motels produce a lot of lint from carpeting and linen changes, and will require more frequent filter changes. Check filters at 60-day intervals for the first year until experience is acquired. If light cannot be seen through the filter when held up to sunlight or a bright light, it should be changed. A more critical standard may be desirable.
3. The condensate drain pan should be checked annually and cleaned and flushed as required.
4. Record performance measurements of volts, amps, and water temperature differences (both heating and cooling). A comparison of logged data with start-up and other annual data is useful as an indicator of general equipment condition.
5. Periodic lockouts almost always are caused by air or water problems. The lockout (shutdown) of the unit is a normal protective result. Check for dirt in the water system, water flow rates, water temperatures, airflow rates (may be a dirty filter), and air temperatures. If the lockout occurs in the morning following a return from night setback, entering air below machine limits may be the cause.

## Lubrication

R-410A should be used only with polyester (POE) oil. The HFC refrigerant components in R-410A will not be compatible with mineral oil or alkylbenzene lubricants. R-410A systems will be charged with the OEM recommended lubricant, ready for use with R-410A.

## Charging

Due to the zeotropic nature of R-410A, it should be charged as a liquid. In situations where vapor is normally charged into a system, a valve should be installed in the charging line to flash the liquid to vapor while charging.

**Note:** *Because a water source heat pump operates under a wide range of water and air temperatures, the values printed below are to be taken as suggested pressure and temperatures. All Daikin water source heat pumps are designed for commercial use. The units are designed for both heating and cooling operation and fail safe to cooling. The reversing valve is energized for the heating mode of operation*

Superheat	Head Pressure	Water Delta T
8 to 14 degrees	335-355 PSIG	10° to 14°

- Notes:**
1. All information above is based on ISO standard 13256-1 and tested at these conditions.
  2. Operating conditions shall be within the limits established in [Table 28](#), and [Table 29](#) on page 47.

**Table 30: Troubleshooting refrigeration circuit**

Symptom	Head Pressure	Suction Pressure	Compressor Amp Draw	Super Heat	Subcooling	Air Temp Differential	Water (Loops) Temp Differential	Safety Lock Out
Charge	Low	Low	Low	High	Low	Low	Low	Low Pressure
Undercharge System (Possible Leak)								
Overcharge System	High	High	High	Normal	High	Normal Low	Normal	High Pressure
Low Air Flow Heating	High	High	High	High Normal	Low	High	Low	High Pressure
Low Air Flow Cooling	Low	Low	Low	Low Normal	High	High	Low	Low Temp
Low Water Flow Heating	Low Normal	Low Normal	Low	Low	High	Low	High	Low Temp
Low Water Flow Cooling	High	High	High	High	Low	Low	High	High Pressure
High Air Flow Heating	Low	Low	Low	Low	High	Low	Low	Low Temp
High Air Flow Cooling	Low	High	Normal	High	Low	Low	Normal	High Pressure
High Water Flow Heating	Normal	Low	Normal	High	Normal	Normal	Low	High Pressure
High Water Flow Cooling	Low	Low	Low	Low	High	Normal	Low	Low Temp
TXV Restricted	High	Low	Normal Low	High	High	Low	Low	





## Unit Check / Equipment Data

### Installation Data

**Job Name** \_\_\_\_\_ **Check Test Date:** \_\_\_\_\_  
**City** \_\_\_\_\_ **State** \_\_\_\_\_ **Zip** \_\_\_\_\_  
**Daikin Model #** \_\_\_\_\_  
**Daikin Serial #** \_\_\_\_\_ **Job site Unit ID # (HP #)** \_\_\_\_\_  
**General Contractor:** \_\_\_\_\_ **Mechanical Contractor:** \_\_\_\_\_  
**Technician Performing Start-Up: Name** \_\_\_\_\_ **Employer:** \_\_\_\_\_  
**Complete equipment data from measurements taken at the locatons indicated on the drawing below.**

### Equipment Data

**Flow Rate** **EWP - LWP = ΔP**  
 ① EWP - PSI In \_\_\_\_\_ minus ② LWP - PSI Out \_\_\_\_\_ equals ΔP \_\_\_\_\_  
 The first step in finding GPM is to subtract leaving water pressure from entering water pressure. The difference between the two is referred to as ΔP. ΔP can be converted to GPM by looking in the equipment specification catalog.  
**Caution ΔP ≠ GPM**  
**Note: A conversion table must be used to find GPM from (Delta) ΔP measurements.**

**Loop Fluid Temperature Rise / Drop through Coaxial Heat Exchanger** **EWT - LWT = ΔT**  
 ③ EWT - °F Out \_\_\_\_\_ minus ④ LWT - °F Out \_\_\_\_\_ equals Fluid ΔT \_\_\_\_\_  
 ΔT is the rise or drop in the fluid temperature as it passes through the Coaxial.

**Air Temperature Rise / Drop through the air coil** **ΔT x CFM x 1.08 = BTUH Sensible**  
 ⑤ EAT - °F In \_\_\_\_\_ minus ⑥ LAT - °F Out \_\_\_\_\_ equals Air ΔT \_\_\_\_\_

**Note: Perform Check, Test and Start-Up in the Cooling Mode Only.**

EWT - Entering Water Temperature	EWP - Entering Water Pressure	EAT - Entering Air Temperature	Δ- Delta (Differential)
LWT - Leaving Water Temperature	LWP - Leaving Water Pressure	LAT - Leaving Air Temperature	CFM - Cubic Feet/Minute
			BTUH - British Thermal Units/Hour

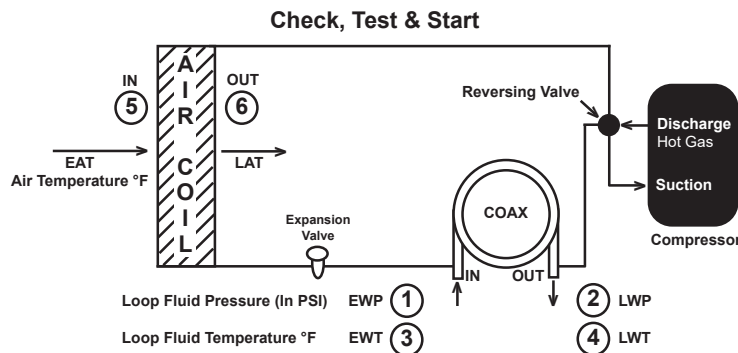



**Commercial Check, Test and Start Worksheet**  
 (Complete all equipment measurements indicated for each unit per installation on page 2)

	Model	Serial #	H.P. #	EWT ③	LWT ④	EWP ①	LWP ②	EAT ⑤	LAT ⑥	Volts	Amps Cooling	Check Air Filter and Coil	Comments (more comments on back)
1.													
2.													
3.													
4.													
5.													
6.													
7.													
8.													
9.													
10.													
11.													
12.													
13.													
14.													
15.													
16.													
17.													
18.													
19.													
20.													
21.													
22.													
23.													
24.													
25.													
26.													
27.													
28.													
29.													
30.													
31.													
32.													
33.													
34.													
35.													
36.													
37.													
38.													
39.													
40.													
41.													
42.													









### ***Daikin Applied Training and Development***

Now that you have made an investment in modern, efficient Daikin equipment, its care should be a high priority. For training information on all Daikin HVAC products, please visit us at [www.DaikinApplied.com](http://www.DaikinApplied.com) and click on Training, or call 540-248-9646 and ask for the Training Department.

### ***Warranty***

All Daikin equipment is sold pursuant to its standard terms and conditions of sale, including Limited Product Warranty. Consult your local Daikin Applied representative for warranty details. Refer to Form 933-430285Y. To find your local Daikin Applied representative, go to [www.DaikinApplied.com](http://www.DaikinApplied.com).

### ***Aftermarket Services***

To find your local parts office, visit [www.DaikinApplied.com](http://www.DaikinApplied.com) or call 800-37PARTS (800-377-2787). To find your local service office, visit [www.DaikinApplied.com](http://www.DaikinApplied.com) or call 800-432-1342.

This document contains the most current product information as of this printing. For the most up-to-date product information, please go to [www.DaikinApplied.com](http://www.DaikinApplied.com).

Products manufactured in an ISO Certified Facility.