

Installation and Maintenance Manual

IM 1171-8

Group: **WSHP/FCU**

Part Number: **IM1171-8**

Date: **March 2024**

Digitally Adjustable Display Sensor



Used with:

Water Source Heat Pumps (WSHP) - Sensor Part No. 910121754

SmartSource™ Units with MicroTech® III Controls:
Models GC, GS, GT

SmartSource™ Units with MT2300 Controls:
Models SC, SM, SS

Enfinity™ Units with MicroTech® III Controls:
Models CCH, CCW, VFC, VFW; LVC, LVW; MHC, MHW, VHC,
VHF

Fan Coil Units (FCU) - Sensor Part No. 910113679, 910152148
Models With MicroTech III Controls - 910113575

Contents

Overview	2	Front Panel Button Operation	7
Sensor buttons & dimensions	2	Occupied icon indicator	7
Applications	3	"OVERRIDE" on the display	7
Sensor functions	3	Fan status & speed indicators	7
Mounting, Maintenance, Terminations	4	System mode "HEAT/COOL/AUTO/OFF/DHUM" indicators	7
Mounting	4	"ALARM" on the display	7
Maintenance	4	"E-SAVE" word on the display	7
Terminations	4	"SETPOINT" word on the display	7
Initial Start-up, Display Descriptions	6	"STATUS" word & dot on the display	7
Terminal descriptions	6	Front panel button operation	7
Initial start-up occupied sequence	6	Optional Technician Adjustments	9
Power fail start-up occupied sequence	6	Optional technician adjustments	9
Display descriptions	6	Diagnostics	11
Adjusting the setpoint	6	Specifications	12

Overview

The display sensor is used in conjunction with the MicroTech III or MT2300 equipped units as described in the Application Section below. The same sensor is used for Water Source Heat Pump (WSHP) and for Fan Coil Units (FCU) with just a hardware jumper and menu change during configuration. The sensor has a digital display for Temperature, Humidity, Occupancy, Fan Speed, System Mode, Alarm, Setpoint and Status indication. Controls include six buttons for Setpoint, System Mode, Fan Speed, Occupied/Unoccupied Request, and Override Reset. (Figure 1).

Sensor buttons & dimensions

Figure 1: Digital display sensor - Water Source Heat Pump P/N 910121754, Fan Coil P/N 910113679, 910113575, 910152148

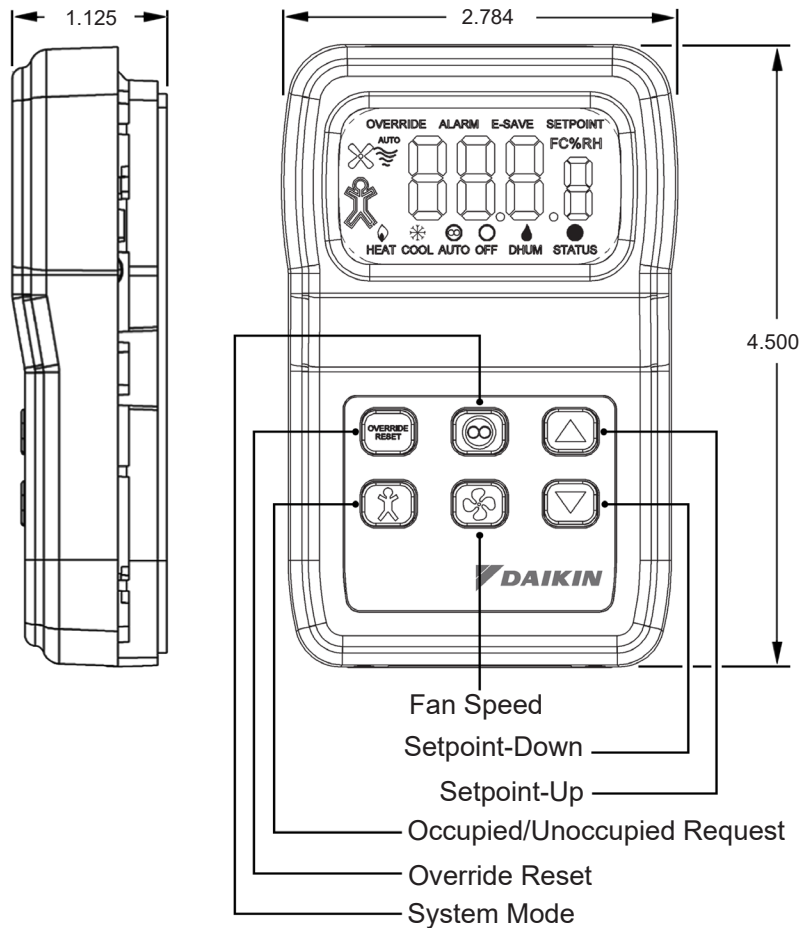

Applications

The display sensor can be used on the products shown in [Table 1](#).

Table 1: Product usage guide

Units	Product		Models	Controls	Used with Digitally Adjustable Sensor with Temperature and Humidity Display
Water Source Heat Pumps	Horizontal	Enfinity™	CCH, CCW	MicroTech III or MT2300 Unit Controller	Yes
	Vertical		LVC, LVW, VFC, VFW		
	Vertical Stacked		VHC		
	Console		MHC, MHW		
	Horizontal & Vertical	SmartSource 1-Stage	GSH, GSV, SCH, SMH, SSH		
		SmartSource 2-Stage	GTH, GTV, GDH		
Fan Coils	Horizontal	ThinLine™	FC.H, FH.H	MicroTech III Unit Controller	Yes
	Vertical		FC.V, FH.V		

The display sensor for water source heat pump applications is shown in [Table 2](#).

Table 2: Water source heat pump application guide

Units	Product	Models	Applications												
			Cooling	Heating	Dehumidification					Electric Heat			Waterside Economizer		
					Stages	Smart Dehumidification	Hot Gas Reheat	Simplified	Humidistat Controlled	Dehumidification Only	Boilerless	Supplemental		Primary	3-Way Valve Control
Water Source Heat Pumps	Horizontal	Enfinity	CCH, CCW	1 or 2	1 or 2	No	Yes	No	No	No	No	Yes ¹	No	No	Yes
	Vertical		VFC, VFW	1	1	No	Yes	No	No	No	No	Yes ¹	Yes ¹	No	No
			LVC, LVW	3	2	No	Yes	No	No	No	No	Yes ¹	No	No	Yes
	Vertical Stacked		VHC	1	1	No	No	No	No	No	No	No	No	No	No
	Console		MHC, MHW	1	1	No	No	No	No	No	No	Yes ¹	Yes ¹	No	No
	Horizontal & Vertical	Smart-Source 1-Stage	GSH, GSV, SCH, SMH, SSH	3	4	Yes	Yes	Yes	Yes	Yes	Yes	Yes	Yes	Yes	Yes
	Horizontal & Vertical	Smart-Source 2-Stage	GTH, GTV, GDH	3	4	Yes	Yes	Yes	Yes	Yes	Yes	Yes	Yes	Yes	Yes

Note: ¹With optional Boilerless controls

Sensor functions

910152148, 910113575, 910113679, Fan-coil unit model:

- Display sensor to show room Temperature, fan speed (AUTO/HIGH/MEDIUM/LOW), system mode (HEAT/COOL/AUTO/OFF), ALARM, Override and occupancy.

Note: 910113575 will not display a temperature value as this is measured using a unit-mounted return air sensor.

910121754, Water source heat pump model:

- Display sensor to show room Temperature, room humidity, fan speed (AUTO/ON), system mode (HEAT/COOL/AUTO/OFF/DHUM), ALARM, Override and occupancy.
- De-humidification output contact has an adjustable setpoint and configurable deadband. This output operates automatically using the RH setpoint and deadband in the system “AUTO” mode or in the “DHUM” mode.

Mounting, Maintenance, Terminations

Mounting

Location

Avoid mounting on outside walls or in direct sunlight.

Junction Box, (J-Box)

1. Pull the wire through the wall and out of the junction box, leaving about six inches free.
2. Pull the wire through the hole in the base plate.
3. Secure the back plate to the box using the #6-32 × 1/2 inch mounting screws provided.
4. Screw the plate firmly to the wall so the foam plate backing is compressed about 50%.
5. Terminate the unit according to the guidelines in the Termination section.
6. Attach Cover by latching it to the top of the base, rotating it down and snapping into place.
7. Secure the cover by backing out the lock-down screws using a 1/16" Allen wrench until it is flush with the bottom of the cover.

Figure 2: Junction box mounting (hardware is provided for both junction box and drywall installation.)

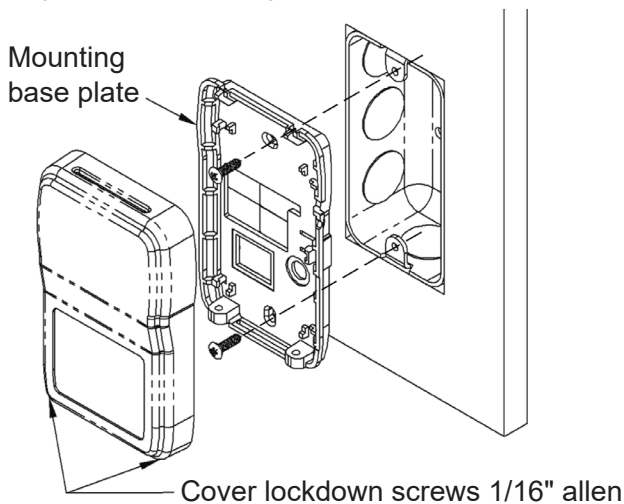

Drywall mounting

1. Place the base plate against the wall where you want to mount the sensor.
2. Mark out the two mounting holes where the unit will be attached to the wall. Drill a 3/16" hole in the center of each mounting hole and insert a drywall anchor into the holes.
3. Drill one 1/2" hole in the middle of the marked wiring through hole area.
4. Pull the wire through the wall and out the 1/2" hole, leaving about six inches free.
5. Pull the wire through the hole in the base plate.

6. Secure the base to the drywall anchors using the #6 × 1" mounting screws provided.
7. Screw the plate firmly to the wall so the foam plate backing is compressed about 50%.
8. Terminate the unit according to the guidelines in the Termination section.
9. Attach cover by latching it to the top of the base, rotating it down and snapping it into place.
10. Secure the cover by backing out the lock-down screws using a 1/16" Allen wrench until it is flush with the sides of the cover

Note: *in any wall-mount application, the wall temperature and the temperature of the air within the wall cavity can cause erroneous readings.*

The mixing of room air and air from within the wall cavity can lead to condensation, erroneous readings and sensor failure. To prevent these conditions, Daikin recommends sealing the conduit leading to the junction box with fiberglass.

Maintenance

Wipe the display as needed with a damp water only cotton cloth. Do not use any type of cleaner as it may damage the buttons or scratch the display. Do not paint.

Terminations

Daikin recommends using a twisted shielded pair of at least 22AWG for the power wire connections. The shield should be earth grounded only at the power source. Larger gauge wire may be required for long runs.

Figure 3: Sensor Circuit Board

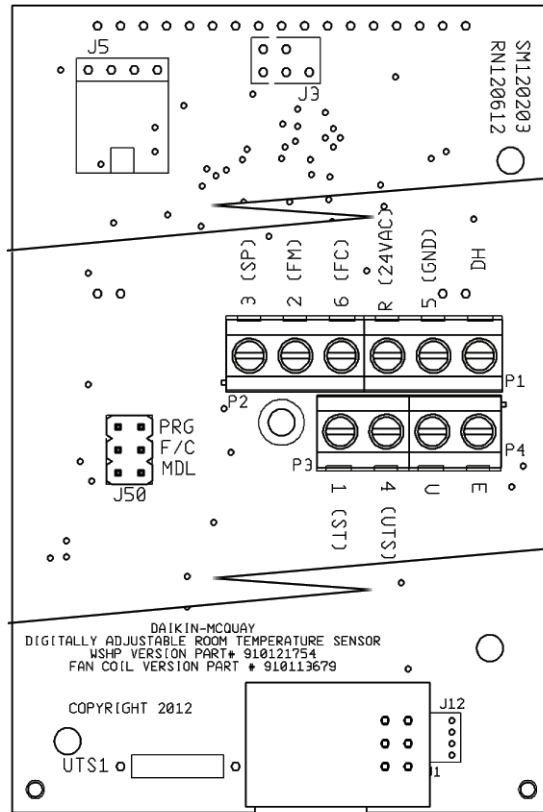

CAUTION

Combination of power wiring (R, 5, DH) and analog (1, 2, 3, 4, and 6 to ground) wiring in a common cable may cause signal interference and must be avoided.

All wiring must comply with the National Electric Code (NEC) and local codes. Do NOT run any of this device's wiring in the same conduit as other AC power wiring. Tests show that fluctuating and inaccurate signal levels are possible when AC power wiring is present in the same conduit as the signal lines. If you are experiencing any of these difficulties, please contact your Daikin representative.

Figure 4: SmartSource MicroTech III board to digital room temperature sensor wiring

SmartSource Board	MicroTech III Board									I/O Expansion Module
	Base Board									
Terminal Block Label	TB2-1	TB1-1	TB1-2	TB1-3	TB1-4	TB1-5	TB3-1	TB3-2	TB1-1	
Description	24VAC	Unit Status Output	Fan & Unit Mode	Setpoint Adjust	Room Temp Sensor & Tenant Override	DC Signal Common	Emergency Shutdown Input	Unoccupied Input	Dehumidification Input	
Terminal Label	R	1	2	3	4	5	E	U	1	
Typical Wiring										
Terminal Label	R (24VAC)	1 (ST)	2 (FM)	3 (SP)	4 (UTS)	5 (GND)	6 (FC)	E	U	DH
Description	24VAC	Unit Status Output	Fan & Unit Mode	Setpoint Adjust	Room Temp Sensor & Tenant Override	DC Signal Common	Fan Speed Select - Fan Coil Version Only	Emergency Shutdown	Unoccupied	Dehumidification
Sensor	Digitally Adjustable Room Temperature Sensor (Part No. 910121754)									

Figure 5: Fan-Coil MicroTech III board to digital room temperature sensor wiring

SmartSource Board	MicroTech III Board							
	Base Board							
Terminal Block Label	TB2-2	TB1-5	TB1-4	TB1-3	TB1-2	TB1-1	TB1-6	TB2-1
Description	24VAC	Unit Status Output	Unit Mode	Fan Mode	Setpoint Adjust	Room Temp Sensor & Tenant Override	DC Signal Common	Unoccupied
Terminal Label	24 VAC	BO9	AI7	AI4	AI3	AI1	COM	BI2
Typical Wiring								
Terminal Label	R (24VAC)	1 (ST)	2 (FM)	6 (FC)	3 (SP)	4 (UTS)	5 (GND)	U
Description	24VAC	Unit Status Output	Fan & Unit Mode	Fan Speed Select - Fan Coil Version Only	Setpoint Adjust	Room Temp Sensor & Tenant Override	DC Signal Common	Unoccupied
Sensor	Digitally Adjustable Room Temperature Sensor (Part No. 910113679, 910152148, 910113575)							

Figure 6: SmartSource MT2300 controller to digital room temperature sensor wiring

SmartSource Board	MT2300 Board								I/O Expansion Module	
Terminal Block Label	TB1-1	TB2-1	TB2-2	TB2-3	TB2-4	TB2-5	TB3-1	TB3-2	TB1-3	
Description	24VAC	Unit Status Output	Fan & Unit Mode	Setpoint Adjust	Room Temp Sensor & Tenant Override	DC Signal Common	Emergency Shutdown Input	Unoccupied Input	Dehumidification Input	
Terminal Label	R	LED	FM	SP	RM	GND	E	U	HST	
Typical Wiring	↕	↕	↕	↕	↕	↕	↕	↕	↕	
Terminal Label	R (24VAC)	1 (ST)	2 (FM)	3 (SP)	4 (UTS)	5 (GND)	6 (FC)	E	U	DH
Description	24VAC	Unit Status Output	Fan & Unit Mode	Setpoint Adjust	Room Temp Sensor & Tenant Override	DC Signal Common	Fan Speed Select - Fan Coil Version Only	Emergency Shutdown	Unoccupied	Dehumidification
Sensor	Digitally Adjustable Room Temperature Sensor (Part No. 910121754)									

Terminal descriptions

Note: Refer to "Figure 3: Sensor Circuit Board" on page 5 for terminal locations

- R** 15 to 28VAC* (AC requires separate shielded wire) (Shield terminated at power source only)
- DH** Dehumidification Contact (Triac from R to DH @170mA, WSHP Only).
- U** Unoccupied Contact. (Terminal grounded when in Unoccupied, VDC only).
- E** System "Off" Indication. (Terminal grounded when in System "Off" mode, VDC only).
- 1** Status Indicator Input from the MicoTech III Unit Controller. (5VDC).
- 2** Output Signal, and Fan Mode System (0 to 5VDC). Output Signal, System Mode Select for FCU only, (0 to 5VDC).
- 3** Output Signal, Setpoint Adjust from 55° to 95°F (default) or ±5° Configurable. (0 to 5VDC) See Setpoint Analog Range Tolerances. See Table 3.
- 4** Output Signal, Room Temp Thermistor Sensor. (10K ATP Z curve, 10K-2). 910113575 tenant override only
- 5** Ground or Neutral* (AC requires separate shielded wire). Common Reference for All Signal Terminals.
- 6** Output Signal, Fan Speed Select for FCU only. (0 to 5VDC). Terminal 6 not used for WSHP units.

Note: * The AC power wiring at terminals [R] & [5] should be run in a separate twisted shielded pair to avoid possible fluctuating and inaccurate signal levels induced into the other sensor signal wires.

This sensor AC power can be run in the same conduit with the sensor signal wire as long as it's run in twisted, shielded pair and terminated properly.

Setpoint analog range tolerance

Table 3: Setpoint analog range tolerance

Setpoint Analog Tolerance			
55° to 95°F Scale	-3° to +3°F Scale	-5° to +5°F Scale	Terminal 3 Analog Output
@ 55°F (min.)	@-3°F (min.)	@ -5°F (min.)	0.0 to 0.10 vdc
@65°F	@-1.5°F	@-2.5°F	1.3 to 1.42 vdc
@75°F	@0°F	@0°F	2.12 to 2.2 vdc
@85°F	@+1.5°F	@+2.5°F	2.58 to 2.63 vdc
@95°F (max.)	@+3°F (max.)	@+5°F (max.)	3.0 to 4.0 vdc

Initial Start-Up Sequences

Initial start-up occupied sequence

On initial installation power-up, the sensor is in "Occupied" mode with a solid occupied icon and DC voltage at terminal "U". If the "STATUS/Dot" input on Terminal 1 from the controller indicates occupied ("ON" continuous), then the unit continues to stay "Occupied". If the "STATUS/Dot" input on Terminal 1 from the controller indicates unoccupied (5 seconds "ON" then 5.5 seconds "OFF"), then the occupied icon will flash the desired occupancy state every 8 seconds, indicating to the user a mismatch of the desired occupied status and system occupied status at the controller

Power fail start-up occupied sequence

On a power failure, the sensor retains its last known desired occupancy status in non-volatile memory. On restoration of power, the sensor restores its last known desired occupancy state from memory. The occupied icon will reflect this with a solid (occupied) or hollow (unoccupied) indication and terminal "U" will have voltage applied (occupied) or grounded (unoccupied). If the "STATUS/Dot" input on Terminal 1 from the controller matches this occupancy state then the occupied status icon will continue to be solid or hollow depending on the last known state. If the "STATUS/Dot" input on Terminal 1 from the controller is different from the sensor occupied state, then the occupied icon will flash the desired occupancy state every 8 seconds indicating to the user a mismatch of the desired occupied status and system occupied status at the controller.

Display descriptions

Numerical display

The factory setting default numerical display (Figure 7) shows current temperature (°F or °C) and toggles to humidity and setpoint display every 5 seconds.

Figure 7: Sensor numerical display

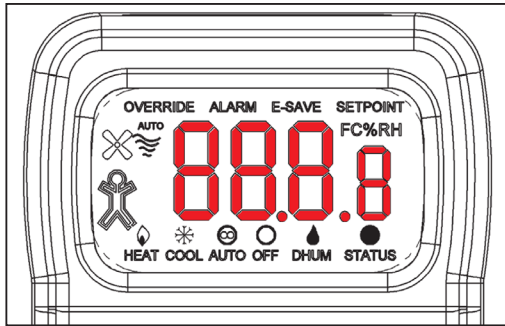

Adjusting the setpoint (Temperature or humidity)

Whichever is displayed at the time, temperature or humidity:

- Push the or button, the displayed setpoint can be adjusted up or down.
- After an adjustment, the setpoint is displayed for 5 seconds.

During the setpoint display push (System Mode Button) to switch between the temperature display or the humidity display.

- Push the or button, the displayed setpoint can be adjusted up or down. (See "Front panel button operation" on page 10 for details.)

The unit can also be programmed in the field to "Setpoint Only" display or Setpoint Lockout. See the "Optional Technician Adjustments" on page 11.

Occupied icon indicator

The Occupied Icon on the left side of the display indicates whether the room sensor is in the Occupied or Unoccupied Mode, (Figure 8).

Figure 8: Occupied & unoccupied icons



Solid is Occupied and Hollow is Unoccupied.

- A blinking icon every 8 seconds indicates an override request that has not been fulfilled.

“OVERRIDE” on the display

The “OVERRIDE” word indicator in the top left corner illuminates when the sensor is signalled by the “Status” input (Terminal 1).

This is initiated from the Override/Reset Button at first and then confirmed from the “Status” input code which keeps the “OVERRIDE” indicator on.

Fan status & speed indicators

- “Fan & No Wavy Lines” indicate the fan is Off.
- “Fan & 2 Wavy Lines” indicate Low.
- “Fan & 3 Wavy Lines” indicate Medium.
- “Fan & 4 Wavy Lines” indicate High, and the word “AUTO” indicate fan Auto mode.

System mode “HEAT/COOL/AUTO/OFF/DHUM” indicators

The “HEAT/COOL/AUTO/OFF/DHUM” Mode Indicators on the bottom of the display describe each of the sensor’s modes. The mode is changed by pushing the System Mode button on the sensor. (Dhum is only used on WSHP units.)

“ALARM” on the display

The “ALARM” word indicator on top illuminates when the sensor interprets the “Status” input code from the controller as an alarm. See on page 9.

“E-SAVE” word on the display

The “E-SAVE” word indicator on top illuminates when the sensor interprets the “Status” input code from the controller as Standby Mode (See on page 9).

“SETPOINT” word on the display

The “Setpoint” word on top illuminates when the sensor is displaying the setpoint on the numerical display (Temperature or Humidity). When this “Setpoint” indicator is off, the numerical display shows the actual room temperature or humidity.

“STATUS” word & dot on the display

The Status “Dot” on the display indicates the unit status or alarm condition. It is turned “On” and “Off” by interpreting the status input from the controller on terminal 1.

Table 4 and Table 5 shows the alternating conditions and sensor status.

Table 4: WSHP unit status input timing definition

Status Dot "ON" (+ 5 vdc) time	Status Dot "OFF" (0 vdc) Time	WSHP Availability	Display Indication
0.5 seconds	0.5 seconds	Controller Off (or Network "Wink" operation active)	"ALARM" On
0.0 seconds	Continuous	Unit running in Night Setback Override Mode or no power to the unit	"OVERRIDE" On
0.5 seconds	5.5 seconds	Unoccupied Mode	Hollow Occupied Icon
5.5 seconds	0.5 seconds	Standby Mode	"E-SAVE" On
Continuous	0.0 seconds	Occupied Mode	Solid Occupied Icon

Table 5: Fan Coil (FCU) unit status input timing definition

Status Dot "ON" (+ 5 vdc) time	Status Dot "OFF" (0 vdc) Time	Fan Coil Availability	Display Indication
0.3 seconds	0.3 seconds	Alarm Active	"ALARM" On
0.0 seconds	Continuous	Unit running in Night Setback Override Mode or no power to the unit	"OVERRIDE" On
0.5 seconds	5.5 seconds	Unoccupied Mode	Hollow Occupied Icon
5.5 seconds	0.5 seconds	Standby Mode	"E-SAVE" On
Continuous	0.0 seconds	Occupied Mode	Solid Occupied Icon
3.0 seconds	3.0 seconds	Calibration Mode/ Network Wink	No Change

Front panel button operation

System mode indication (FCU only)

"HEAT/COOL/AUTO/OFF"

The "HEAT/COOL/AUTO/OFF" Mode Indicators on the bottom of the display show the mode status of the sensor and are changed by pushing the System Mode button.

- "HEAT" on the display means the unit will only provide heating.
- "COOL" on the display means the unit will only provide cooling.
- "AUTO" on the display means the unit switches automatically to provide cooling or heating.
- "Off" on the display means the unit will not provide cooling, heating or fan operation.

There should always be one indicator "ON" unless the sensor has no power or has a problem. The System Mode Analog Output voltage on Term. 2 will change based on the system mode.

Fan speed indication (FCU only)

"AUTO/HIGH/MEDIUM/LOW"

The Fan Speed Indicators on the display show the fan speed

status (AUTO/HIGH/MEDIUM/LOW) and are changed by pushing the Fan Mode button.



"Fan & 4 Wavy Lines & AUTO" - the fan stages up or down automatically depending on the demand for HEAT/COOL.



"Fan & 4 Wavy Lines" - the fan runs continuously at high speed regardless of the system mode setting of HEAT/COOL/AUTO.



"Fan & 3 Wavy Lines" - the fan runs continuously at medium speed regardless of the system mode setting of HEAT/COOL/AUTO.



"Fan & 2 Wavy Lines" - the fan runs continuously at low speed regardless of the system mode setting of HEAT/COOL/AUTO.



"Fan & No Wavy Lines" - Indicates the fan is Off.

There should always be one indicator "On" unless the sensor has no power or has a problem. The Fan Speed Analog Output voltage on Terminal 6 will change based on the fan speed selection.

System mode indication (WSHP only)

"HEAT/COOL/AUTO/OFF/DHUM"

The "HEAT/COOL/AUTO/OFF/DHUM" Mode Indicators on the display show the mode status of the sensor and are changed by pushing the System Mode button.

- "HEAT" on the display means the unit will only provide heating.
- "COOL" on the display means unit will only provide cooling.
- "AUTO" on the display means the unit can switch automatically to provide cooling or heating or dehumidification.
- "OFF" on the display means the unit will not provide cooling, heating, dehumidification or fan operation ("E" terminal goes Low).
- "DHUM" on the display means that only dehumidification will operate.

There should always be one indicator "On" unless the sensor has no power or has a problem. The System Mode Analog Output voltage on Terminal 2 will change based on the system mode selection.

Fan indication (WSHP only)

"AUTO/ON"

The Fan Indicators on the left side of the display show the fan status (AUTO/ON) of the sensor and are changed by pushing the Fan Mode button.



"Fan & 4 Wavy Lines & AUTO" - the fan runs on a call for HEAT/COOL/DHUM. Otherwise the fan is off.



"Fan & 4 Wavy Lines" - the fan runs continuously regardless of the system mode setting of HEAT/COOL/AUTO/DHUM.



"Fan & No Wavy Lines" - the fan is Off when the system mode is "Off".



Override/Reset button (timed override & alarm reset)

When the "Override/Reset" Button is pressed, the thermistor sensor is shorted. If held for more than 3 seconds but less than 11 seconds, it puts the controller into a timed Occupied Override (the time is set by the controller). If the unit is in alarm, then holding the "Override/Reset" Button for more than 11 seconds will clear all alarms in the controller but only if the cause of the alarm has already returned to its non-alarm condition. Some alarms will not reset from the digital room sensor.

In this case, power to the unit must be cycled off for 5 seconds to clear the alarm. Continuously resetting alarms from the room sensor could damage the controller. Please call a service technician when repeated alarm resets are required to keep the unit operational.



Occupied button (occupied/unoccupied request)

Note: Terminal "U" opens HI to source power on power-up "Occupied"

When the "Occupancy" Button is pushed, the current "Occupied" or "Unoccupied" status of the sensor will be toggled to the opposite condition for 20 seconds. Both the display and "U" terminal output reflect the new status during the 20 seconds. If a confirmation signal is received from the controller into the Status Input terminal "1" within 20 seconds, then the new occupancy condition remains; otherwise the "U" terminal will return to the original state and the "Occupied" Icon will flash the desired occupancy state every 8 seconds.



Up & down setpoint buttons temp or humidity)

Press the Setpoint "Up/Down" Buttons once to enter the Setpoint Adjustment Mode. View the display to see whether the unit is in Temperature or Humidity Setpoint mode. If needed, press the "System Mode" Button once to toggle to the desired Setpoint. The current setpoint value will display for 5 seconds. When the "Up/Down" Buttons are pressed in this mode, the temperature or humidity setpoint will change in one degree or percent (%) increments. It will only change within the temperature setpoint range that was ordered (or the setpoint range that was set via the Program Mode).

The humidity setpoint is always between 40% to 90%. After 5 seconds of no buttons being pushed, the sensor will go into the standard display mode.

Optional Technician Adjustments



System mode button (FCU has HEAT/COOL/AUTO/OFF) or (WSHP has HEAT/COOL/AUTO/OFF/DHUM)

When the "System" Button is pushed, the unit switches between system modes.



Fan mode button (FCU has AUTO/HIGH/MEDIUM/LOW/OFF) (WSHP has AUTO/ON)

When the "Fan" Button is pushed, the fan speed changes in order from one speed to another.

Note: The sensor setup is factory set per your order. Setup

adjustments are not required

The unit is shipped ready to install per the order and does not require any special setup or programming. The following Program Menu Changes are available if the installer decides to change the factory settings. The Setpoint Up/Down Buttons and Occupancy Button are used in the Programming Mode to make Menu changes and selection.

Set-up jumper (J50) configuration (Factory set per order)

CAUTION

Turn off power to the unit before reconfiguring the F/C or MDL jumper settings. Damage to the sensor board can occur if jumpers are moved while there is power to the unit and sensor.

Figure 9: J50 Jumper

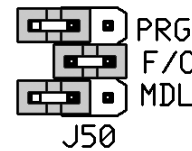

Label description setting

PRG	Program Mode or Run Mode	Program Mode = Jumper installed for Program Mode (See Program Menu below). Run Mode = Jumper removed for Run Mode (Place jumper on one pin only).
F/C	°C Indication or °F Indication	°C = Jumper installed for °C . °F = Jumper removed for °F Indication (Place jumper on one pin only). 910152148, 910113575
MDL	Sets the Model FCU or WSHP	910113679 = Jumper removed for FCU (Default for units ordered as FCU). 910121754 = Jumper installed for WSHP (Default for units ordered as WSHP).

Program mode menu pages:

(Display required)

Note: Both J50 "F/C" and J50 "MDL" jumpers must be configured first before entering the program "PRG" mode.

Entering program mode and making changes

1. Install the J50 "PRG" jumper onto both pins with power turned on to enter Program Mode.
2. Press the Up/Down Buttons to advance to the desired program parameter from P1 through P14 (Parameters described below).
3. Press the Occupancy Button to select the specific program parameter to change.

4. Change the parameter value as described in the Mode Menus section below. (Usually with the Up/Down Button)
5. Press the Occupancy Button again to set the selected parameter.
6. Press the Up/Down Buttons to proceed to the next parameter (as in Step 2 above).
7. When done making changes, remove the J50 "PRG" jumper (and place over one pin). This action will end the Programming Mode and store all the values. The sensor is now in the Run Mode.

Program mode menu pages

P1 Setpoint Mode (Factory set to temperature value "S1". J50 °F/°C must be set before entering the program "PRG" mode).

- **S1** – "UP/DOWN" to select setpoint to absolute temperature setpoint value. Actual setpoint value set in P4 and P5. **Example:** 55°F (13° C) to 95°F (35° C).
- **S2** – "UP/DOWN" to select setpoint to relative temperature setpoint value of ±5.0°F (±2.8°C).
- **S3** – "UP/DOWN" to select setpoint to relative temperature setpoint value of ±3.0°F (±1.67°C) for Infinity systems.

P2 Temperature Offset (Factory set to zero).

- "UP" to increase offset up to +2.
- "DOWN" to decrease offset down to -2.

P3 Humidity Offset (Factory set to zero).

- "UP" to increase offset up to +5
- "DOWN" to decrease offset down to -5.

P4 Setpoint Low Range (Factory set to 55°F or 13°C depending on J50 °F/°C setting).

P1 in S1 Mode: Adjustment range 55 to 65°F or 13 to 18°C.

- "UP" to increase the low setpoint range up to 65°F or 18°C.
- "DOWN" to decrease the low setpoint range down to 55°F or 13°C.

P1 in S2 Mode: No adjustment. Factory set to -5°F (-2.8°C).

P1 in S3 Mode: No adjustment. Factory set to -3°F (-1.6°C) for Infinity systems.

P5 Setpoint High Range (Factory set to 95°F or 35°C depending on J50-°F/°C setting).

P1 in S1 Mode: Adjustment range 85 to 95°F or 29 to 35°C.

- "UP" to increase the high setpoint range up to 95°F or 35°C.
- "DOWN" to decrease the high setpoint range down to 85°F or 29°C.

P1 in S2 Mode: No adjustment. Factory set to 5°F (2.8°C).

P1 in S3 Mode: No adjustment. Factory set to 3°F (1.6°C) for Infinity systems.

P6 Fan Lock Mode (Factory set to Unlocked "Unl")

- "UP/DOWN" to set Fan Lock mode. Choose from list below:

All Models	Unl	Enables fan to be controlled by the Sensor Fan button
All Models	FA	Locks fan to the Fan Auto position (No Sensor Fan button control)
WSHP Models	FO	Locks fan to the Fan On position (No Sensor Fan button control)
FCU Models	FH	Locks fan to the Fan High speed position (No Sensor Fan button control)
FCU Models	Fd	Locks fan to the Fan Medium speed position (No Sensor Fan button control)
FCU Models	FL	Locks fan to the Fan Low speed position (No Sensor Fan button control)
FCU Models	Fo	Locks fan to the Fan Off position (No Sensor Fan button control)

P7 System Lock Mode (Factory set to Unlocked "Unl")

- "UP/DOWN" to set System Lock mode. Choose from list below:

Unl	Enables System to be controlled by the Sensor System Mode button.
UH	Locks System to the Heat mode (No Sensor System button control).
UC	Locks System to the Cool mode (No Sensor System button control).
UA	Locks System to the Auto mode (No Sensor System button control).
UO	Locks System to the Off mode (No Sensor System button control).
Ud	Locks System to the Dhum mode (No Sensor System button control).

P8 Display Resolution (Factory set to ±0.5 resolution, "0.5").

- 0.1** "UP/DOWN" to set resolution to ±0.1, (Rounds up at .05).
- 0.5** "UP/DOWN" to set resolution to ±0.5, (Rounds up at .08).
- 1** "UP/DOWN" to set resolution to ±1.0, (Rounds up at .5).

P9 Dehumidification Dead band (DB) (Factory set to 2%), (WSHP Only).

- 2** "UP/DOWN" to set Dead band at 2% (On at setpoint SP, Off at SP-DB).
- 3** "UP/DOWN" to set Dead band at 3% (On at setpoint SP, Off at SP-DB).
- 4** "UP/DOWN" to set Dead band at 4% (On at setpoint SP, Off at SP-DB).
- 5** "UP/DOWN" to set Dead band at 5% (On at setpoint SP, Off at SP-DB).

P10 Display Mode (Factory set to #16 for WSHP units, factory set to #4 or #3 for FCU Units).

- "UP/DOWN" to set display mode.
- Choose from numbered list below. Choices 5-16 will not be shown if P12 = nOH.

- 1 = No value on the main display (Blank).
- 2 = Temperature Value (TV).

- 3 = Temperature Setpoint (TSP) (FCU Default 910113575).
- 4 = Temperature Value & Temperature Setpoint (FCU Default 910152148, 910113679).
- 5 = Humidity Value (HV).
- 6 = Temperature Value & Humidity Value.
- 7 = Humidity Value & Temperature Setpoint.
- 8 = Temperature Value, Temp Setpoint & Humidity Value.
- 9 = Humidity Setpoint (HSP).
- 10 = Temperature Value & Humidity Setpoint.
- 11 = Temperature Setpoint & Humidity Setpoint.
- 12 = Temperature Value & Temp Setpoint & Humidity Setpoint.
- 13 = Humidity Value & Humidity Setpoint.
- 14 = Temperature Value, & Humidity Value & Humidity Setpoint.
- 15 = Humidity Value & Temperature Setpoint & Humidity Setpoint.
- 16 = Temperature Value & Temperature Setpoint & Humidity Value & Humidity Setpoint (WSHP Default).

P11 Setpoint Button Lockout (Factory set to "0": Temp. & Humidity Setpoint Enabled).

Note: 1. Selections in P11 will impact Menu P10).
 2. After changing P11 option, remove PRG jumper on J50 to exit programming mode and refresh options. In order to make additional programming changes, PRG Jumper must be reinstalled to enter programming mode.

- 0 Both Temperature & Humidity Setpoints are enabled (No Setpoint lockout, WSHP Units Only).
- 1 Humidity Setpoint Only is Enabled (Temperature setpoint is locked out, WSHP Units Only).
- 2 Temperature Setpoint Only is Enabled (Humidity setpoint is locked out).
- 3 Both Temperature & Humidity Setpoints are Disabled (Full Setpoint lockout).

Optional Technician Adjustments

P12 Dehumidification Enable/Disable
nOH Dehumidification is Disabled (Factory default for FCU Units).
HuA Dehumidification is Enabled (Factory default for WSHP Units).

P13 Occupancy Button Enable/Disable (Factory set to enabled "ObE").
ObE Occupancy Button Enabled (Factory default)
Obd Occupancy Button Disabled

P14 Firmware Version - XXX.X

P15 For Units with a BACnet or LonWORKS Communications Module

Setpoint Calibration Offset (Factory set to "0".)
 • "UP" to increase offset up to +100 will raise the MicroTech III perceived set point from the sensor.
 • "DOWN" to decrease offset down to -100. This will lower

the MicroTech III perceived set point from the sensor.
Calibrate the displayed set point to the set point value sent to the MicroTech III as follows:

1. Set the digital room sensor displayed set point to 90° F.
2. Observe the local set point via the BAS/EMS connected by the BACnet or LonWorks Communications Module.
3. Adjust the Configuration Menu P15 on the sensor until the local set point and the displayed set point are equal.

P15 For Units without a BACnet or LonWORKS Communications Module

Setpoint Calibration Offset (Factory set to "0".)
 • "UP" to increase offset up to +100 will raise the MicroTech III perceived set point from the sensor.
 • "DOWN" to decrease offset down to -100. This will lower the MicroTech III perceived set point from the sensor.

The Setpoint Calibration Offset can be calculated using the following formula:

$$\text{ROUND}[(\text{Controller Vdd} / \text{Sensor Vdd}) * 1000] - 1000$$

Example:

Given: Controller Vdd = 5.15VDC
 Sensor Vdd = 4.95 VDC

The programmed Calibration Offset would be
 $[(5.15/4.95) * 1000] - 1000 = 40$

Diagnostics

Problem & possible solution

No display

- Check the power connections and power voltage level
- Replace unit if power is okay.

No temperature signal

- Be sure the termination and wiring is correct and the controller is set up properly. Make sure the "Override/Reset" button is not stuck down.
- Replace unit if all checks are okay.

Override/Reset not working

- Measure the resistance to ground at the sensor output terminal (Term. 4). When pushing the Override Button, it should show a short. If not, replace the sensor.

No fan voltage signal

- Be sure the termination and wiring is correct and the controller is set up properly.
- Replace unit if all checks are okay.

No system voltage signal

- Be sure the termination and wiring is correct and the controller is set up properly.
- Replace unit if all checks are okay.

De-humidification not working

- Adjust the System Mode to DHUM and check terminal DH for voltage.
- Change the RH setpoint above and below the ambient RH to prove the output contact.
- Replace unit if it still doesn't work.

Occupied not working

- Verify that this terminal is in a powered circuit. Measure the voltage to ground at the occupied terminal (U). When pushing the Occupied Button (<2 secs), it should read close to 0 volts. When you lift the button it should read high volts.
- Replace unit if it still doesn't work.

"Err" shown on the screen

- This indicates that the temperature and humidity sensing element has failed.

FAN key does not change fan mode

- Check to verify FAN is not locked out in Programming Mode Menu Page P6.

MODE key does not change system mode

- Check to verify Mode is not locked out in Programming Mode Menu Page P7.

Up or Down key does not change setpoints

- Check to verify Set points are not locked out in Programming Mode Menu Page P11.

Solid Man goes away after 20 seconds

- Occupancy Request was not acknowledged by Main controller, check wiring of Status Signal from controller.

Supply voltage

AC Hot.....(R) 7 to 28VAC, 24VAC nominal, 0.17VA
 GND/Neutral.....(5) Sensor common reference ground.

Sensor

Temperature 10K-2 Thermistor, ±0.36°F (±0.2°C)
 Humidity.....2% Accuracy from 20 to 80%,
 Capacitive.

Outputs

Unoccupied.....(U), Unoccupied = Digital low to ground (Same ground as power source), 100mA @5VDC max.
 Dehumidify.....(DH), = Dehumidify = Voltage output (same as supply voltage), 170mA max.
 System Off.....(E), System Off = Digital low to ground (Same ground as power source), 100mA @5VDC max.
 Fan Speed(2 or 6), Analog, 0 to 5 VDC.
 System Mode.....(2), Analog, 0 to 5 VDC.
 Setpoint(3), Analog, 0 to 5 VDC.
 Temperature(4), Analog thermistor resistance.

Sensor controls

Setpoint2 Up/Down buttons
 System.....1 button to cycle between Heat/Cool Auto/Off/Dhum/Off
 Fan1 button to cycle between Auto/High/On.
 Occupied1 button to check and request change in Occupancy Status.
 Override/Reset1 button to request timed occupancy override and reset alarms.
 Inputs:.....(1), Controller alarm & system status, 5VDC max.
 Termination:.....10 Terminals, 16 to 22 AWG.
 Mounting:.....Standard 2" × 4" J-Box or Drywall

Field setup jumper J50

PRG Program Mode, On = Program, Off = Run.
 F/C.....Display Units, On = °C, Off = °F.
 MDL.....MODEL, On = WSHP. Off = FCU.

Display

LCD

Overall size.....2.04"W × 1.33"H.
Main Digits.....±999.9 Digits @0.6"H
Resolution.....0.5 displayed value, 0.1 for offset adjust
Main Value.....Temp, Humidity & Setpoint, toggling every 5 sec.
Eng. Units.....°F, °C, %RH.
System.....Heat/Cool/Auto/Off/Dhum.
FanAuto/High/Medium/Low.
Occupied IconHollow = Unoccupied, Solid = Occupied.
Function.....Override, Alarm, E-Save, Setpoint

Field configuration menu

(Requires J50 PRG jumper to be "On")

Offset.....Temp or Humidity display, ±2°F (±1.0°C) and ±5% RH.
Setpoint rangeDefault 55° to 95°F (13° to 35°C), ±3°F (±1.6°C) or ±5°F (±3°C). Adjustable between 55° to 95°F, ±3°F (±1.6°C) or ±5.0°F (±2.8°C).
Fan Lock-in.....Any fan speed or off can be locked in System Lock-in. Any system mode can be locked in
Resolution.....Main display can be default .5, or .1 or 1.0 (°F, °C or %).
Display Mode.....Temp only, RH only, Setpoint only or any combination.
Dhum DBDehumidify Dead Band adjust, 2% default.

Enclosure material

ABS Plastic, UL94V-0.

Ambient

32° to 122°F (0° to 50°C), 0 to 95%RH, Non-condensing.

Agency

Restriction of the use of certain Hazardous Substances (RoHS).