

SMARTSOURCE®

VERTICAL STACK WATER SOURCE HEAT PUMP



Model WSVF



Model WSVC

- MODELS WSVF & WSVC
- UNIT SIZES 009 – 036
- R-32 REFRIGERANT

Safety Information	3	Field Installed Accessories	38
Hazard Identification	3	Wireless Temperature Control	38
Safety Considerations	3	Motorized Isolation Valve Kit	39
UL Compliance Statements for Unit Work	4	Typical Wiring Diagrams	40
Unit Labels	4	Operation	49
Introduction	5	Start-Up	49
Model Nomenclature	5	Controls	50
General Information	8	Configuration DIP Switches	52
Receiving and Handling	8	MicroTech SmartSource Unit Controller	53
Prior to Installing	10	MT2300 Controller with an Optional BACnet® Communication Module	56
Dimensional Data	13	Maintenance	57
System Applications	24	Troubleshooting	57
Water System Quality	24	Refrigerant Information	58
Operating Limits	26	Refrigerant Guidelines	58
Antifreeze Correction Factors	26	Typical Refrigeration Cycles	61
Installation	27	Appendix	63
Risers and Cabinet	27	WSHP Warranty Registration	63
Power Wiring from Building to Unit	29	Limited Product Warranty	66
Drain Hose Connections	31		
Water Connections	32		



©2024 Daikin Applied, Minneapolis, MN. All rights reserved throughout the world. This document contains the most current product information as of this printing. Daikin Applied Americas Inc. has the right to change the information, design, and construction of the product represented within the document without prior notice. For the most up-to-date product information, please go to www.DaikinApplied.com.

™@ SmartSource, MicroTech, SiteLine, and Daikin Applied are trademarks or registered trademarks of Daikin Applied Americas Inc. The following are trademarks or registered trademarks of their respective companies: BACnet from American Society of Heating, Refrigerating and Air-Conditioning Engineers, Inc.; Echelon, LonWorks, LonMark, and LonTalk from Echelon Corporation; Modbus from Schneider Electric; and Windows from Microsoft Corporation.

Safety Information

Hazard Identification

DANGER

Danger indicates a hazardous situation, which will result in death or serious injury if not avoided.

WARNING

Warning indicates a potentially hazardous situations, which can result in property damage, personal injury, or death if not avoided.

CAUTION

Caution indicates a potentially hazardous situations, which can result in minor injury or equipment damage if not avoided.

NOTICE

Notice indicates practices not related to physical injury.

Safety Considerations

This manual provides installation and maintenance information for Daikin Applied SmartSource Vertical Stack Water Source Heat Pump with a MicroTech® controller.

NOTICE

Installation and maintenance are to be performed only by licensed, if required by local codes and regulations, or qualified personnel who are familiar with local codes and regulations and are experienced with this type of equipment.

A means for disconnection must be incorporated in the fixed wiring in accordance with the wiring rules for stationary appliances not fitted with means for disconnection from the supply mains having a contact separation in all poles that provide full disconnection under overvoltage category III.

DANGER

LOCKOUT/TAGOUT all power sources prior to service, pressurizing, depressurizing, or powering down the unit. Failure to follow this warning exactly can result in serious injury or death. Disconnect electrical power before servicing the equipment. More than one disconnect may be required to de-energize the unit. Be sure to read and understand the installation, operation, and service instructions within this manual.

WARNING

Electric shock hazard. Improper handling of this equipment can cause personal injury or equipment damage. This equipment must be properly grounded. Connections to and service of the MicroTech control panel must be performed only by personnel that are knowledgeable in the operation of the equipment being controlled.

WARNING



This unit contains R-32, a class A2L refrigerant that is flammable. This unit should only be installed, serviced, repaired, and disposed of by qualified personnel licensed or certified in their jurisdiction to work with R-32 refrigerant. Installation and maintenance must be done in accordance with this manual. Improper handling of this equipment can cause equipment damage or personal injury.

For installation only in locations not accessible to the general public.

Be aware that R-32 refrigerant may not contain an odor. Place in a well ventilated area to prevent accumulation of refrigerant. When installing the unit in a small room, take measures to keep the refrigerant concentration from exceeding allowable safety limits. Excessive refrigerant leaks, in the event of an accident in a closed ambient space, can lead to oxygen deficiency.

Do not pierce or burn this unit.

Never use an open flame during service or repair. Never store in a room with continuously operating ignition sources (for example: open flames, an operating gas appliance, or an operating electric heater), where there is ignitable dust suspension in the air, or where volatile flammables such as thinner or gasoline are handled.

Only use pipes, nuts, and tools intended for exclusive use with R-32 refrigerant in compliance with national codes (ASHRAE15 or IRC).

Do not mix air or gas other than R-32 in the refrigerant system. If air enters the refrigerant system, an excessively high pressure results, which may cause equipment damage or injury.

Do not use means to accelerate the defrosting process or to clean, other than those recommended by the manufacturer.

For more information, consult "Refrigerant Guidelines" on [page 58](#).

WARNING

Polyester Oil, commonly known as POE oil is a synthetic oil used in many refrigeration systems, and may be present in this Daikin Applied product. POE oil, if ever in contact with PVC/CPVC, will coat the inside wall of PVC/CPVC pipe causing environmental stress fractures. Although there is no PVC/CPVC piping in this product, please keep this in mind when selecting piping materials for your application, as system failure and property damage could result. Refer to the pipe manufacturer's recommendations to determine suitable applications of the pipe.

WARNING

This equipment generates, uses, and can radiate radio frequency energy. If not installed and used in accordance with this instruction manual, it may cause interference with radio communications. Operation of this equipment in a residential area is likely to cause harmful interference in which case the owner will be required to correct the interference at the owner's own expense.

Daikin Applied disclaims any liability resulting from any interference or for the correction thereof.

WARNING

When moving flammable A2L refrigerant to/from the unit from an auxiliary tank, a grounding strap must be used. An electrical charge builds when halo-carbon refrigerant travels in a rubber hose. A grounding strap must be used between the auxiliary refrigerant tank and the unit's end sheet (earth ground), which will safely take the charge to the ground. A fire risk could occur if this procedure is not followed.

CAUTION

Static sensitive components. A static discharge while handling electronic circuit boards can cause damage to the components. Discharge any static electrical charge by touching the bare metal inside the control panel before performing any service work. Never unplug any cables, circuit board terminal blocks, or power plugs while power is applied to the panel.







UL Compliance Statements for Unit Work

- All maintenance staff and others working in the local area shall be instructed on the nature of work being carried out. Work in confined spaces shall be avoided.
- Work shall be undertaken under a controlled procedure so as to minimize the risk of a flammable gas or vapor being present while the work is being performed.
- The area shall be checked with an appropriate refrigerant detector prior to and during work, to ensure the technician is aware of potentially toxic or flammable atmospheres. Ensure that the leak detection equipment being used is suitable for use with all applicable refrigerants, i.e., non-sparking, adequately sealed or intrinsically safe.
- If any hot work is to be conducted on the refrigerating equipment or any associated parts, appropriate fire extinguishing equipment shall be available to hand. Have a dry powder or CO2 fire extinguisher adjacent to the charging area.
- No person carrying out work in relation to a refrigerating system which involves exposing any pipe work shall use any sources of ignition in such a manner that it may lead to the risk of fire or explosion. All possible ignition sources, including cigarette smoking, should be kept sufficiently far away from the site of installation, repairing, removing and disposal, during which refrigerant can possibly be released to the surrounding space.
- Prior to work taking place, the area around the equipment is to be surveyed to make sure that there are no flammable hazards. Safety checks are necessary to ensure that the risk of ignition is minimized and "No Smoking" signs shall be displayed.
- Ensure that the area is in the open or that it is adequately ventilated before breaking into the system or conducting any hot work. A degree of ventilation shall continue during the period that the work is carried out. The ventilation should safely disperse any released refrigerant and preferably expel it externally into the atmosphere.

- Equipment not to be used by persons (including children) with reduced physical, sensory or mental capabilities, or lack of experience and knowledge, unless they have been given supervision or instruction.
- Children shall not be allowed to play on or with equipment.
- If unit is permanently connected to water main; hose sets are not to be used.

Unit Labels

Pictogram warning and informational labels may be present on the unit. Consult the table below for reference.

Label	Description
 Refrigerant class per ISO 817	WARNING - flammable refrigerant present
	Read the technical manual for service instructions
	WARNING - A2L low-burning velocity refrigerant present
	Pressurized medium present
	Ultraviolet (UV) radiation present
	Read the technical manual for instructions
	WARNING - flammable refrigerant present

Introduction

Model Nomenclature

Table 1: Model Nomenclature

1	2-3	4	5-7	8	9	10-12	13	14	15-16	17	18	19-20	21	22	23-24	25	26
W	SV	C	024	E	1	TTY	C	M	13	A	Y	YY	S	Y	YY	Y	Y
27	28	29	30-32	33	34	35	36	37	38	39	40	41	42	43-44	45-47	48-50	
Y	N	Y	088	Y	Y	Y	Y	Y	Y	Y	S	2	L	YY	YYY	YYY	

Category	Code Position	Code	=	Description
Product Category	1	W	=	Water Source Heat Pump
Model Type	2-3	SV	=	SmartSource Vertical Stack
Configuration	4	C	=	Chassis
		F	=	Cabinet
Nominal Capacity	5-7	009	=	9,000 BtuH Nominal Cooling
		012	=	12,000 BtuH Nominal Cooling
		015	=	15,000 BtuH Nominal Cooling
		018	=	18,000 BtuH Nominal Cooling
		024	=	24,000 BtuH Nominal Cooling
		030	=	30,000 BtuH Nominal Cooling
Voltage	8	036	=	36,000 BtuH Nominal Cooling
		A	=	115/60/1
		E	=	208-230/60/1
Design Series (Vintage)	9	J	=	265/60/1
		1	=	Design Series 1
Discharge Air	10	B**	=	Primary Supply - Back
		F**	=	Primary Supply - Front
		L**	=	Primary Supply - Left
		R**	=	Primary Supply - Right
		T**	=	Primary Supply - Top
	Y**	=	None (Chassis Only)	
	11	*B*	=	Secondary Supply - Back
		F	=	Secondary Supply - Front
		L	=	Secondary Supply - Left
		R	=	Secondary - Right
T		=	Secondary - Top	
Y	=	None (Chassis Only)		
12	**T	=	Tertiary - Top (88", 92", 96" Cabinets Only)	
	**Y	=	None (Chassis Only)	
Water Coil Type	13	C	=	Copper Inner Tube
		G	=	Copper Inner Tube - Geothermal
		S	=	Cupronickel Inner Tube
		J	=	Cupronickel Inner Tube - Geothermal
		Y	=	None (Chassis Only)
Unit Control	14	M	=	MicroTech Unit Controller
		B	=	MicroTech Unit Controller + BACnet
		T	=	MicroTech Unit Controller + Wireless
Fan Motor Options	15	1*	=	PSC
		3*	=	ECM - Constant CFM (015-036)
		5*	=	ECM - Constant Torque (009-012)
	16	*3	=	2 Speed Fan - Unit Toggle Switch
		*4	=	PWM Controlled (ECM Only)

Category	Code Position	Code	=	Description
Insulation	17	A	=	1/2" Fiberglass - Skin Faced
		E	=	3/8" Closed Cell Foam
		F	=	1/2" Fiberglass - Foil Faced (Cabinet Only)
Sound Package	18	S	=	Mass Plate Only
		M	=	Mass Plate & Compressor Blanket (sizes 024-036)
		Y	=	None
Supplemental Heating	19	H*	=	Hot Water Coil - 1-Row
		J*	=	Hot Water Coil - 2-Row
		Y*	=	None
	20	Heater Control Options		
		*V	=	3-way Motorized Valve for Hot Water Coil
		*Y	=	None
Filters	21	S	=	Standard, 1" Fiberglass
		M	=	1" MERV 8
		H	=	2" MERV 13 (Requires EC Motor Option)
		Y	=	None (Chassis Only)
Water Flow Options	22	C	=	2-Way Motorized Iso-Valve, General Close-Off Pressure N.C. (Normally Closed)
		V	=	2-Way Motorized Iso-Valve, General Close-Off Pressure N.O. (Normally Open)
		H	=	2-Way Motorized Iso-Valve, High Close-Off Pressure N.C. (Normally Closed)
		E	=	3-Way Motorized Iso-Valve, General Close-Off Pressure N.C. (Normally Closed)
		G	=	3-Way Motorized Iso-Valve, High Close-Off Pressure N.C. (Normally Closed)
		Y	=	None
Piping Package	23	B*	=	Auto Flow Regulator 1.5 GPM
		C*	=	Auto Flow Regulator 2.0 GPM
		D*	=	Auto Flow Regulator 2.5 GPM
		E*	=	Auto Flow Regulator 3.0 GPM
		F*	=	Auto Flow Regulator 3.5 GPM
		G*	=	Auto Flow Regulator 4.0 GPM
		H*	=	Auto Flow Regulator 4.5 GPM
		I*	=	Auto Flow Regulator 5.0 GPM
		J*	=	Auto Flow Regulator 5.5 GPM
		K*	=	Auto Flow Regulator 6.0 GPM
		L*	=	Auto Flow Regulator 7.0 GPM
		M*	=	Auto Flow Regulator 8.0 GPM
		N*	=	Auto Flow Regulator 9.0 GPM
O*	=	Auto Flow Regulator 10.5 GPM		
		Y*	=	None
	24	*S	=	Strainer
		*Y	=	None
Future Use	25	Y	=	None
Corrosion Protection	26	C	=	Anti-Coil Protection Package
		Y	=	None
Future Use	27	Y	=	None
Electrical Options	28	F	=	Fused Disconnect with Wire Harness
		N	=	Non-Fused Disconnect with Wire Harness
		H	=	HACR Breaker (115V/208-230V only)
Power & Control Access	29	S	=	Side
		T	=	Top
		Y	=	None (Chassis Only)

Category	Code Position	Code	=	Description
Cabinet Height	30-32	080	=	80" Cabinet Height
		088	=	88" Cabinet Height
		092	=	92" Cabinet Height
		096	=	96" Cabinet Height
		KDN	=	63.5" Cabinet Height
		YYY	=	None
Factory Installed Subbase	33	2	=	2 Inch Subbase
		3	=	3 Inch Subbase
		4	=	4 Inch Subbase
		5	=	5 Inch Subbase
		Y	=	None
Secondary Drain Pan	34	G	=	Galvanized
		S	=	Stainless Steel
		Y	=	None (Chassis Only)
Riser Location	35	L	=	Left Cabinet
		R	=	Right Cabinet
		B	=	Back Cabinet
		A	=	Alternate Back Cabinet Piping
		Y	=	None
Riser Mounting	36	F	=	Factory Supplied - Shipped Attached
		J	=	Factory Supplied - Shipped Loose
		Y	=	None
Future	37	Y	=	None
Future	38	Y	=	None
Future	39	Y	=	None
Standard or Special	40	S	=	Standard
		X	=	Special
Packaging	41	1	=	Standard Packaging
		2	=	Multipack Cabinets - Multiple Cabinets on 1 Pallet Group
		C	=	Single Fully Assembled Cabinet - 1 per Pallet - Corrugated
		6	=	63.5" Cabinet Multipack - 4 per Pallet
		7	=	63.5" Single Cabinet - 1 per Pallet
Extended Warranty	42	F	=	4 Year Extended Compressor Only Parts Warranty with 1st Year Labor Allowance
		H	=	4 Year Extended Refrigerant Circuit Parts Warranty with 1st Year Labor Allowance
		J	=	4 Year Extended Complete Unit Parts Warranty with 1st Year Labor Allowance
		L	=	First Year Labor Allowance
		M	=	1 Year Extended Compressor Only Parts Warranty with 1st Year Labor Allowance
		N	=	1 Year Extended Refrigerant Circuit Parts Warranty with 1st Year Labor Allowance
		S	=	1 Year Extended Complete Unit Parts Warranty with 1st Year Labor Allowance
T	=	4 Year Extended Complete Unit Parts Warranty with Labor Allowance		
Secondary Connection Stub Length	43-44	YY	=	None
		06	=	6" Stub Out
Riser Extension Above Cabinet	45-47	YYY	=	None
		A**	=	0-20" Maximum
Riser Extension Below Cabinet	48-50	YYY	=	None
		B**	=	0-20" Maximum

General Information

Daikin Applied Vertical Stack units are designed for use in multiple floor apartments, office buildings, hotels, nursing homes and other similar applications. They require a minimum amount of floor space and are designed for multiple discharge arrangement.

Installation and maintenance must follow accepted industry practices as described in the ASHRAE Handbook, the National Electric Code, and other applicable standards. Install this equipment in accordance with regulations of authorities having jurisdiction and with all applicable codes.

CAUTION

Installation and maintenance are to be performed by qualified personnel who are familiar with local codes and regulations and experienced with this type of equipment.

WARNING

The installer must determine and follow all applicable codes and regulations. This equipment presents hazards of electricity, rotating parts, sharp edges, heat and weight. Failure to read and follow these instructions can result in property damage, severe personal injury, or death. This equipment must be installed by experienced, trained personnel only.

CAUTION

Sharp metal edges are a hazard, use care when servicing to avoid contact with them.

WARNING

This appliance is not intended for use by persons (including children) with reduced physical, sensory or mental capabilities, or lack of experience and knowledge, unless they have been given supervision or instruction concerning use of the appliance by a person responsible for their safety.

Children should be supervised to ensure that they do not play with the appliance.

This appliance shall be installed in accordance with national wiring regulations (national electric code, Canadian electric code).

Receiving and Handling

Carefully check equipment against the bill of lading to ensure all items have been received. Before unloading any unit, check the nameplate to make sure the voltage complies with the power supply available.

Inspect all units for damage upon arrival. If a unit has become dirty during shipment, carefully clean it prior to completing the inspection. Daikin Applied is not responsible for physical damage after the unit leaves the factory unless the contract with Daikin Applied states otherwise.

Check the unit data plate to be sure the unit electrical agrees with the power supply available.

DO NOT handle units by the riser piping. Riser clamps hold the riser in position; they are not designed to support the cabinet weight. The clamps are removed after the unit is installed.

NOTICE

All units should be carefully inspected for damage when received. Report all loss or shipping damage using a claim form supplied by Daikin Applied.

VISIBLE LOSS OR DAMAGE: Any external evidence of loss or damage must be noted on the freight bill or carrier's receipt, and signed by the carrier's agent. Failure to adequately describe such external evidence of loss or damage may result in the carrier's refusal to honor a damage claim.

CONCEALED LOSS OR DAMAGE: Concealed loss or damage means loss or damage which does not become apparent until the unit has been unpacked or unwrapped. The contents may be damaged in transit due to rough handling even though the exterior may not show damages. When the damage is discovered, make a written request for inspection by the carrier's agent within **five (5) days** of the delivery date and file a claim with the form provided by Daikin Applied. Refer to the Daikin Applied Freight Policy for further information.

Cabinet Stacking (One Unit per Crate)

Do not stack over three crates high at any time during transportation or storage.

Figure 1: Cabinet Stacking (One Unit per Crate)

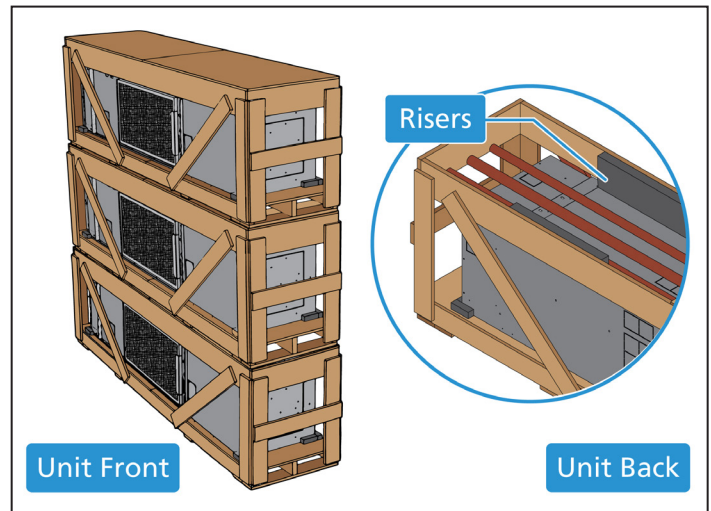

NOTICE

Risers are factory supplied with cabinet for field installation.

Chassis (Four per Skid)

Do not stack over two skid high at any time during transportation or storage. For storing, each carton is marked with “up” arrows

Figure 2: Chassis Stacking (Four per Skid)



Table 2: Overall Shipping Dimensions (Short Stack 63.5" Cabinet Without Factory Attached Risers)

Unit Size	Overall Dimensions
009-012	42-5/8" x 45-1/2" x 67-5/8"
015-018	46-5/8" x 46-3/8" x 67-5/8"
024-036	54-5/8" x 57-1/2" x 67-5/8"

NOTE: 63.5" high cabinets ship from 1 to 4 per skid, vertically, similar to the chassis's as shown above.

Storage and Operating Environment

Temporary storage at the job site must be indoor, completely sheltered from rain, snow, etc. Units should not be installed in environments that fall below freezing or exceed 140°F ambient.

Table 3: Cabinet Packing Overall Dimensions

Unit Size		Cabinet Size		
		18 x 18	18 x 20	24 x 24
009-012	With Riser ¹	21"W x 29"H x 91.5" to 124.5"L		
	Without Risers	21"W x 27"H x 91.5" to 107.5"L		
015-018	With Riser ¹		21"W x 31"H x 91.5" to 124.5"L	
	Without Risers		21"W x 29"H x 91.5" to 107.5"L	
024-036	With Riser ¹			27"W x 35"H x 91.5" to 124.5"L
	Without Risers			27"W x 23"H x 91.5" to 107.5"L

¹ Risers are factory supplied with cabinet for field installation.

Component Descriptions (Assembled Cabinet)

1. Cabinet assembly complete (without chassis):
 - a. Pipe riser sets (return, supply and condensate)
 - b. Inner front panel and filter bracket
2. Cooling and heating chassis (shipped separate)
3. Return air grille/panel (accessory)
4. Double-deflection diffuser (accessory)

Unit cabinets are factory assembled and wired and have individual thermostat control capability. They are installed by stacking one unit on top of the other. While installing, prevent dirt and other foreign matter from entering the risers and plugging lines or valves.

Prior to Installing

Disassembling Upper and Lower Cabinet Sections

The Vertical Stack unit cabinet ships completely assembled. The unit may be disassembled into two sections to make it easier to handle; the upper-fan/discharge cabinet and lower cabinet/return air cabinet.

To disassemble, do the following:

1. Remove risers (if received attached).
2. Remove the two screws (bottom row) on the back of the unit as shown in [Figure 3](#).

Figure 3: Cabinet Disassembly Screw Removal (Rear)

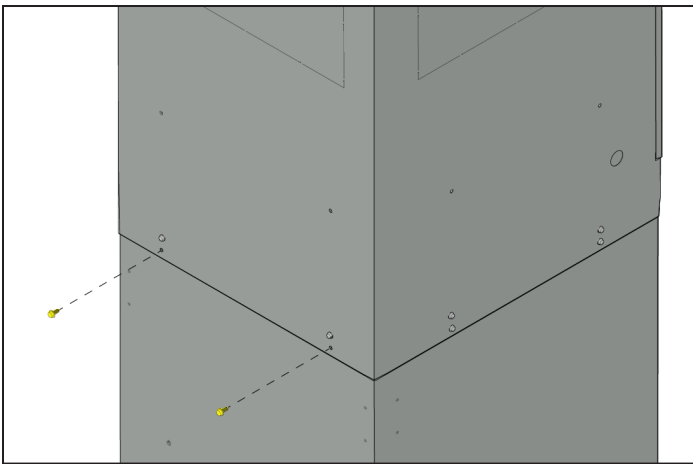

NOTICE

Retain all screws for later use to reassemble unit in reverse order as described in steps 1-6. Number of screws will vary depending on unit size.

3. Carefully lay the unit down on its back and remove the remaining four screws on the left and right side of the cabinet ([Figure 4](#)).

Figure 4: Cabinet Disassembly Screw Removal (Side)

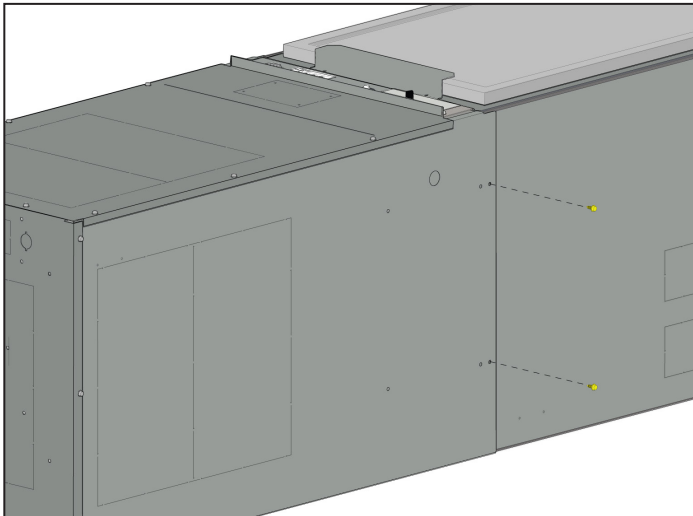

4. Remove the ten screws and lift off the front panel/filter rack to gain access to the cabinet interior ([Figure 5](#)).

Figure 5: Cabinet Disassembly Screw Removal (Front)

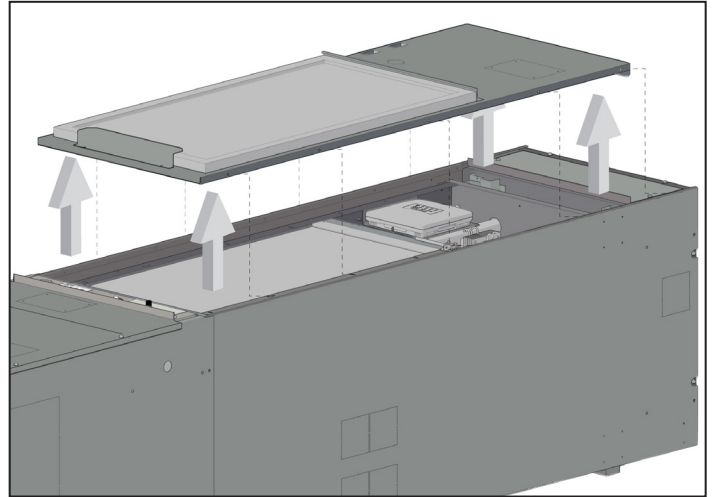

5. Locate and remove the six screws located inside the cabinet joining the upper and lower cabinet sections.

NOTICE

Pull the insulation away from the walls of the cabinet interior to get access to the screws.

Figure 6: Cabinet Disassembly Screw Removal (Inside Unit)

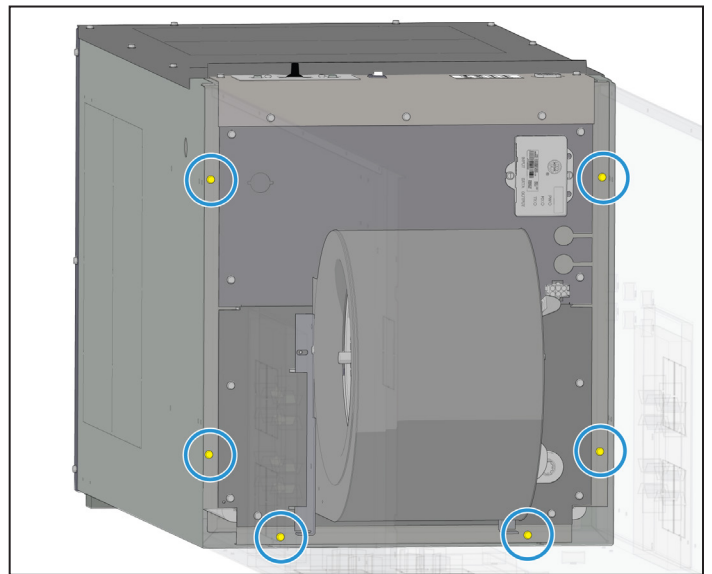

6. Separate the lower return air cabinet section from the upper blower/discharge cabinet section.

Unit Cabinet (WSVF) and Chassis (WSVC)

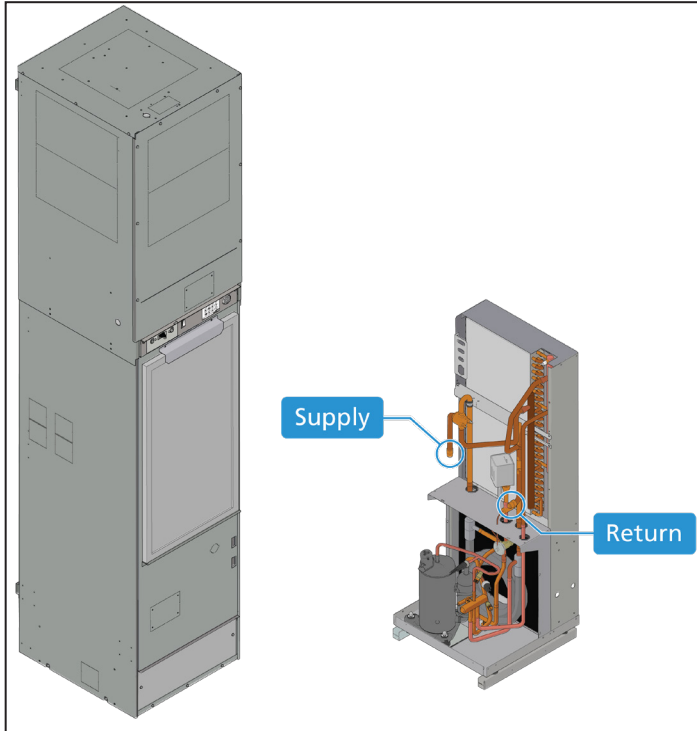

Pre-Installation Considerations

1. To prevent damage to equipment, do not operate supplementary heating and cooling during the construction period.
2. Inspect the carton for any specific tagging numbers indicated by the factory per a request from the installing contractor. At this time the voltage, phase and capacity should be checked against the plans.
3. Check the unit size against the plans to verify that the unit is being installed in the correct location.
4. Before installation, check the available dimensions of the area where the unit is to be installed versus the dimensions of the unit.
5. Note the location and routing of water piping, condensate drain piping, and electrical wiring. The locations of these items are clearly marked on submittal drawings.
6. The installing contractor will find it beneficial to confer with piping, sheet metal, and electrical foremen before installing any unit.

NOTICE

Check the unit data plate for correct voltage with the plans before installing the equipment.

WARNING

Make sure all electrical ground connections are made in accordance with local code.

WARNING

The contractor shall cover the units to protect the machines during finishing of the building. This is critical while spraying fireproofing material on bar joists, sandblasting, spray painting and plastering.

For Optimum Unit Performance and to Help Minimize Noise and Vibration

- Adhere to the "Critical Dimensions" for locations of framing and distances to the cabinet.
- Be sure there are no kinks and that the stainless steel braided hoses do not come in contact with and vibrate on chassis and cause noise.
- Be sure there are no kinks in the condensate drain hose that can restrict flow of condensate to the drain riser.
- Ensure there is no metal-to-metal contact between return air grille and cabinet and the discharge diffuser and the cabinet, use provided gaskets.
- Air balancing in ducted applications is critical for proper airflow at each diffuser.
- It is recommended that all unused openings in the cabinet be sealed to eliminate any air leakage from the cabinet.

NOTICE

Top air discharge units will require turning vanes and/or a volume damper for proper air flow and balancing, to minimize turbulence. These components must be field-installed and furnished in accordance with SMACNA guidelines.

Configurations

Figure 7: Single-Side Discharge

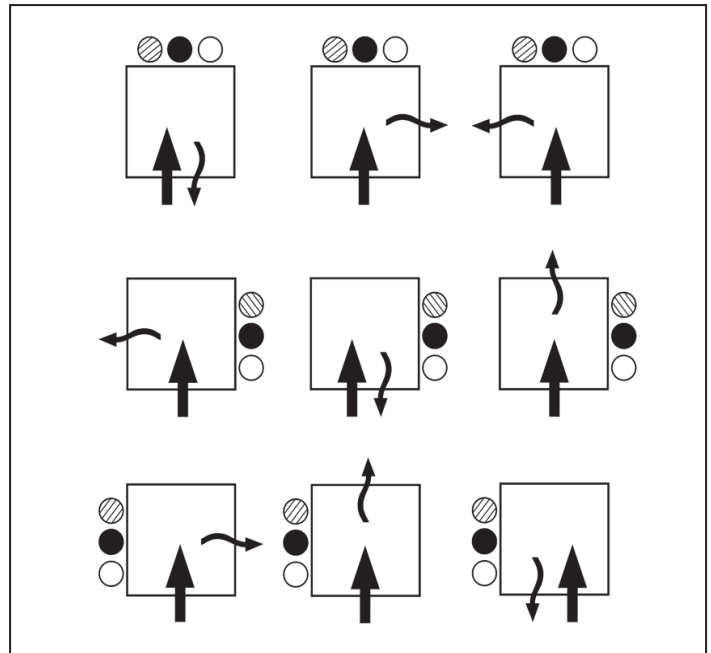

Figure 8: Double-Side Discharge

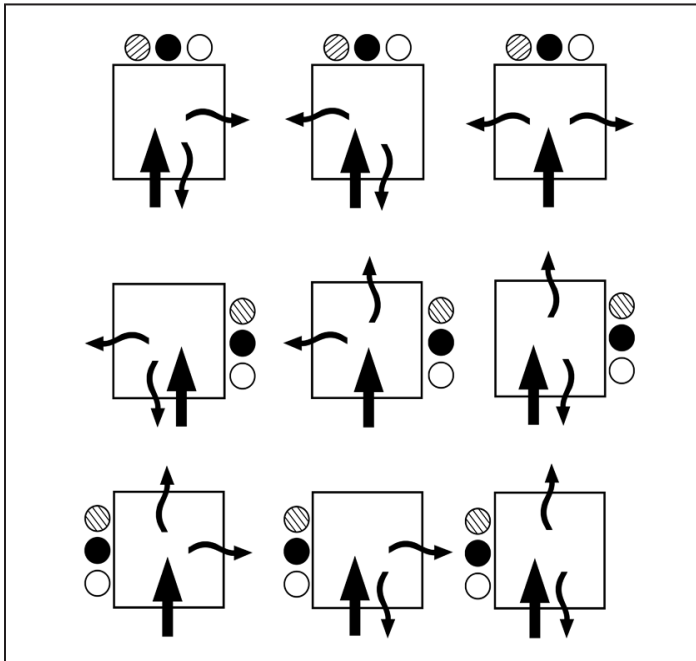

Figure 9: Side and Top Discharge

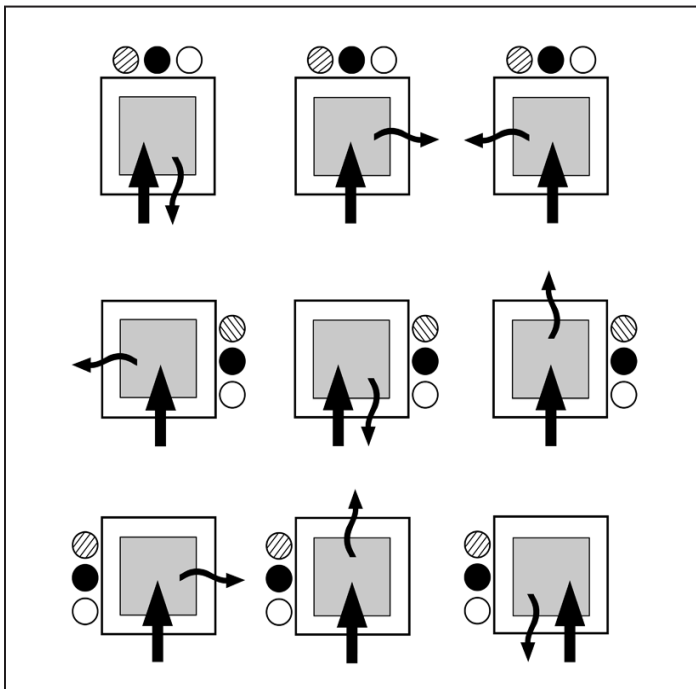

Figure 10: Double-Side and Top Discharge

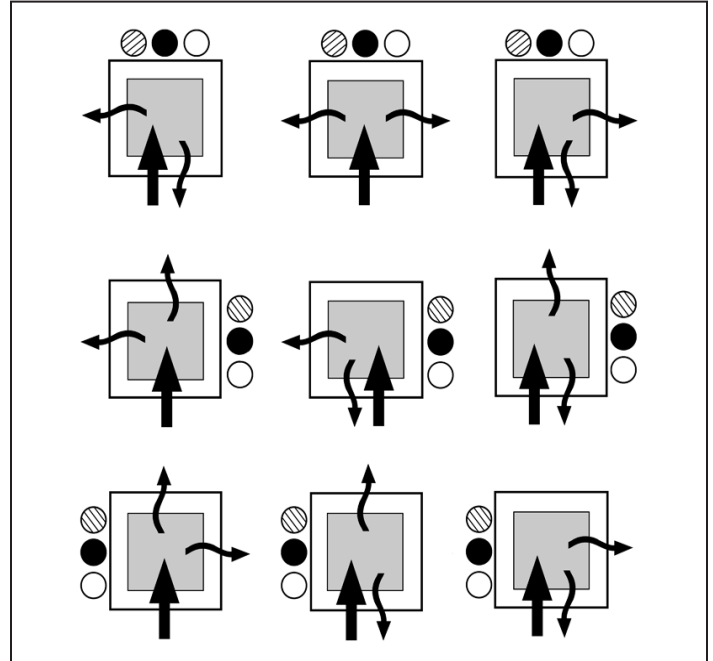

Figure 11: Single Discharge – Top Only

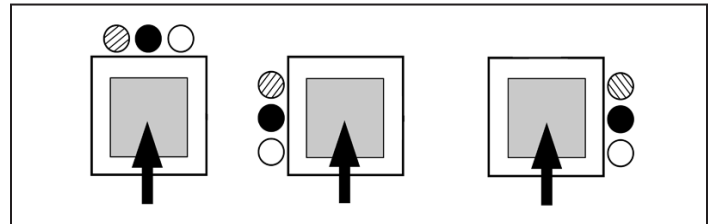
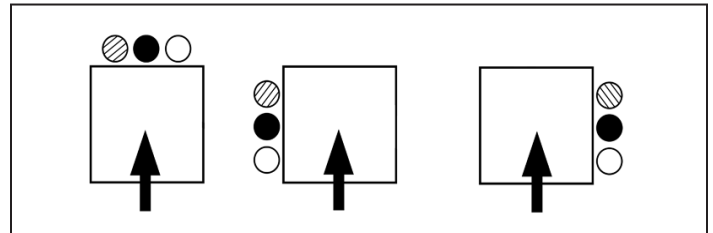

Figure 12: Closed Plenum – Field Modification Required



- = Return Riser
 = Supply Riser
 = Drain
- = Return Air
 = Discharge Air
 = Top Discharge

NOTICE
80" high cabinet not available with side discharge, top discharge only.

Dimensional Data

Model WSVF – 18" × 18" Cabinet – Size 009-012

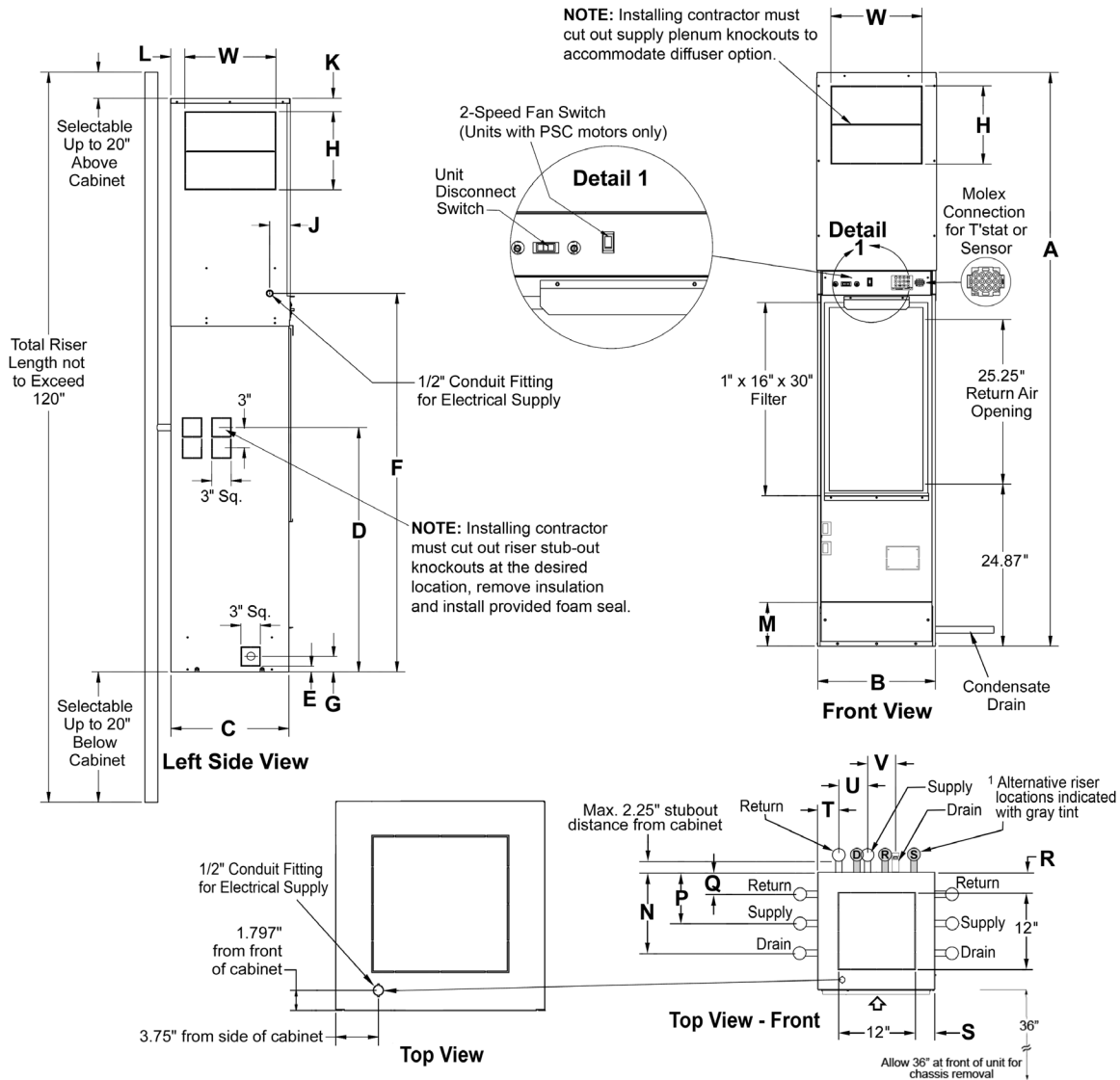

Dimensions

Unit Size 009-018 (18" × 18") Cabinet (Dimensions in inches)																		
Unit Height "A"	B	C	D	E	F	G	J	K	L	M	N	P	Q	R	S	T	U	V
80, 88, 92, 96	18.07	18.11	37.50	0.88	58.09	2.38	3.125	2.0	2.0	6.72	12.4	7.9	3.3	3.0	3.0	3.3	4.5	4.5
Discharge Openings (Dimensions in inches)																		
Unit Size	Single		Double		Triple		Single- Top Opening											
009-012	W	H	W	H	W	H	W	H	W	H								
	14	16	14	8	NR	NR	12	12										

NOTE: ¹Alternative riser locations dimensions mirror those shown as "T", "U", and "V"

NOTE: NR = Not Recommended

80" high cabinet not available with side discharge, top discharge only.

Model WSVF – 18" × 20" Cabinet – Size 015-018

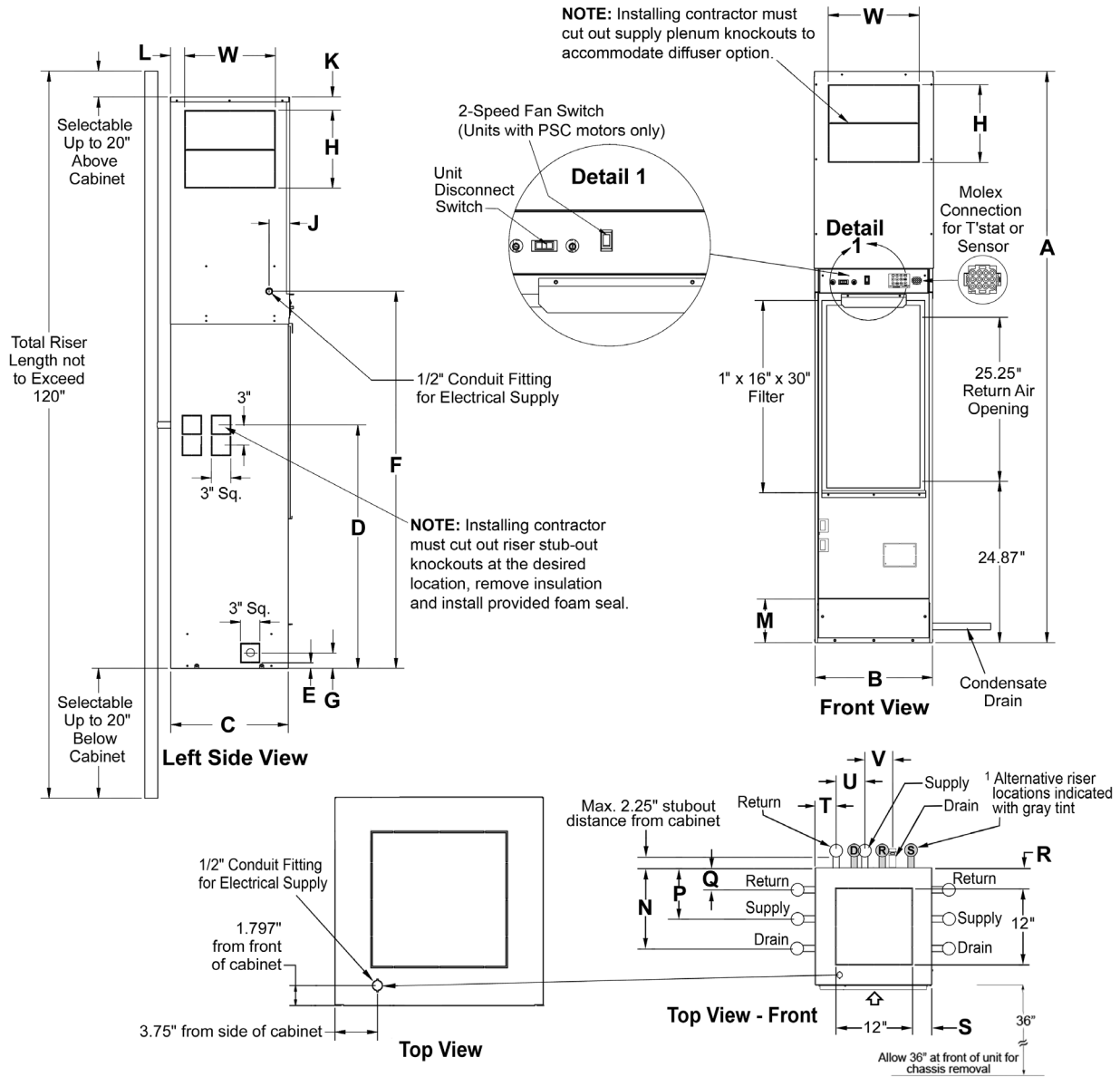

Dimensions

Unit Size 015–018 (18" × 20") Cabinet (Dimensions in inches)																		
Unit Height "A"	B	C	D	E	F	G	J	K	L	M	N	P	Q	R	S	T	U	V
80, 88, 92, 96	18.07	20.00	37.50	0.88	58.09	2.38	3.125	2.0	3.0	6.72	12.4	7.9	3.3	4.0	3.0	3.12	4.5	4.5
Discharge Openings (Dimensions in inches)																		
Unit Size	Single		Double		Triple		Single- Top Opening											
015–018	W	H	W	H	W	H	W	H										
	14	16	14	8	14	8	12	12										

NOTE: ¹ Alternative riser locations dimensions mirror those shown as "T", "U", and "V"

NOTE: 80" high cabinet not available with side discharge, top discharge only.

Model WSVF – 24" × 24" Cabinet – Size 024-036

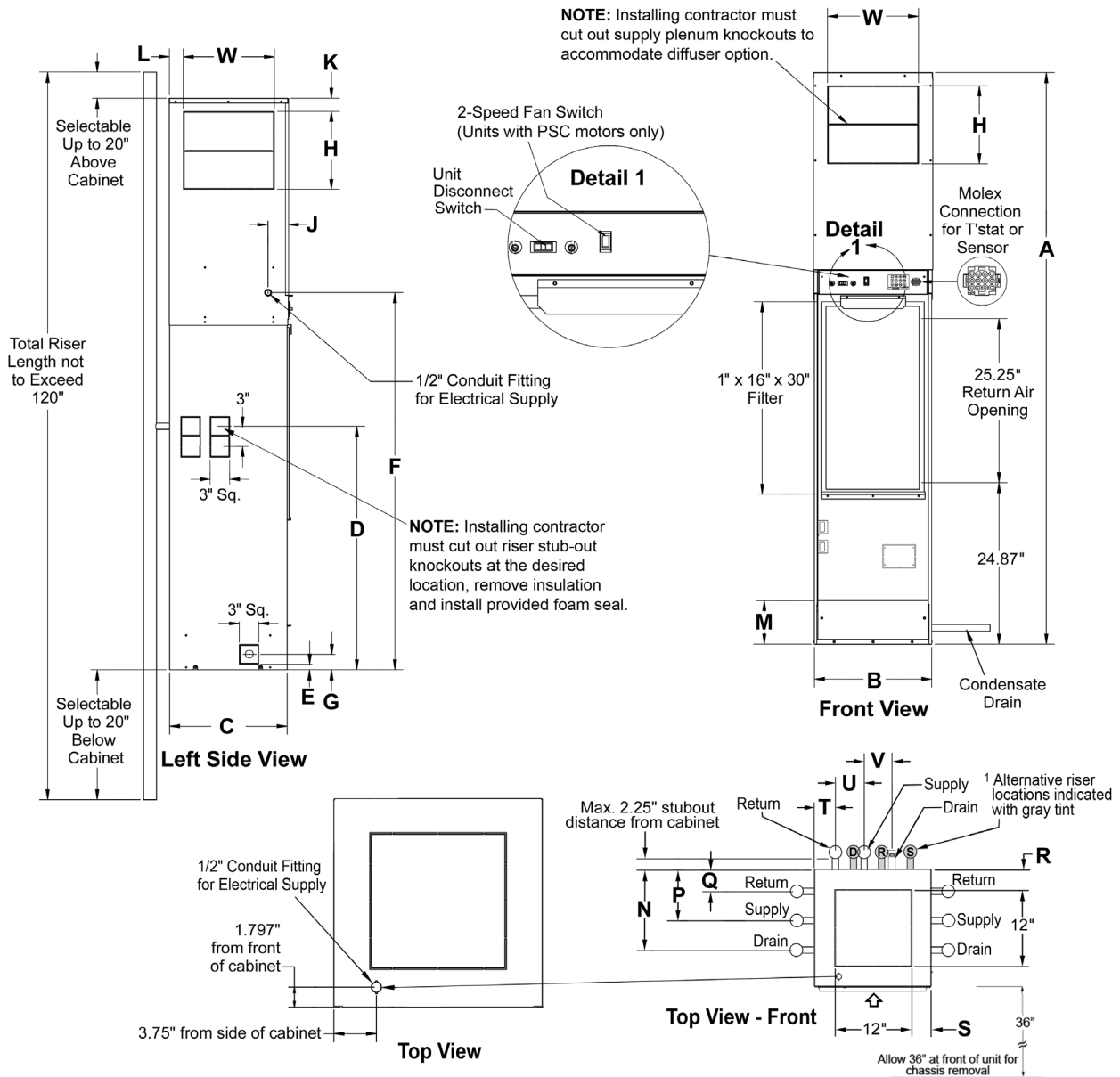

Dimensions

Unit Size 024-036 (24" × 24") Cabinet (Dimensions in inches)																		
Unit Height "A"	B	C	D	E	F	G	J	K	L	M	N	P	Q	R	S	T	U	V
80, 88, 92, 96	24.00	24.04	37.50	0.88	58.08	2.38	4.54	2.0	3.0	6.72	12.4	7.9	3.3	3.09	3.10	3.12	4.5	4.5
Discharge Openings (Dimensions in inches)																		
Unit Size	Single		Double		Triple		Single- Top Opening											
024	W	H	W	H	W	H	W	H	W	H								
	NR	NR	18	10	18	10	18	18	18									
030-036	NR	NR	18	14	18	10	18	18	18									

NOTE: NR = Not Recommended
80" high cabinet not available with side discharge, top discharge only.

Model WSVF 63.5" High Cabinet - Sizes 009-018

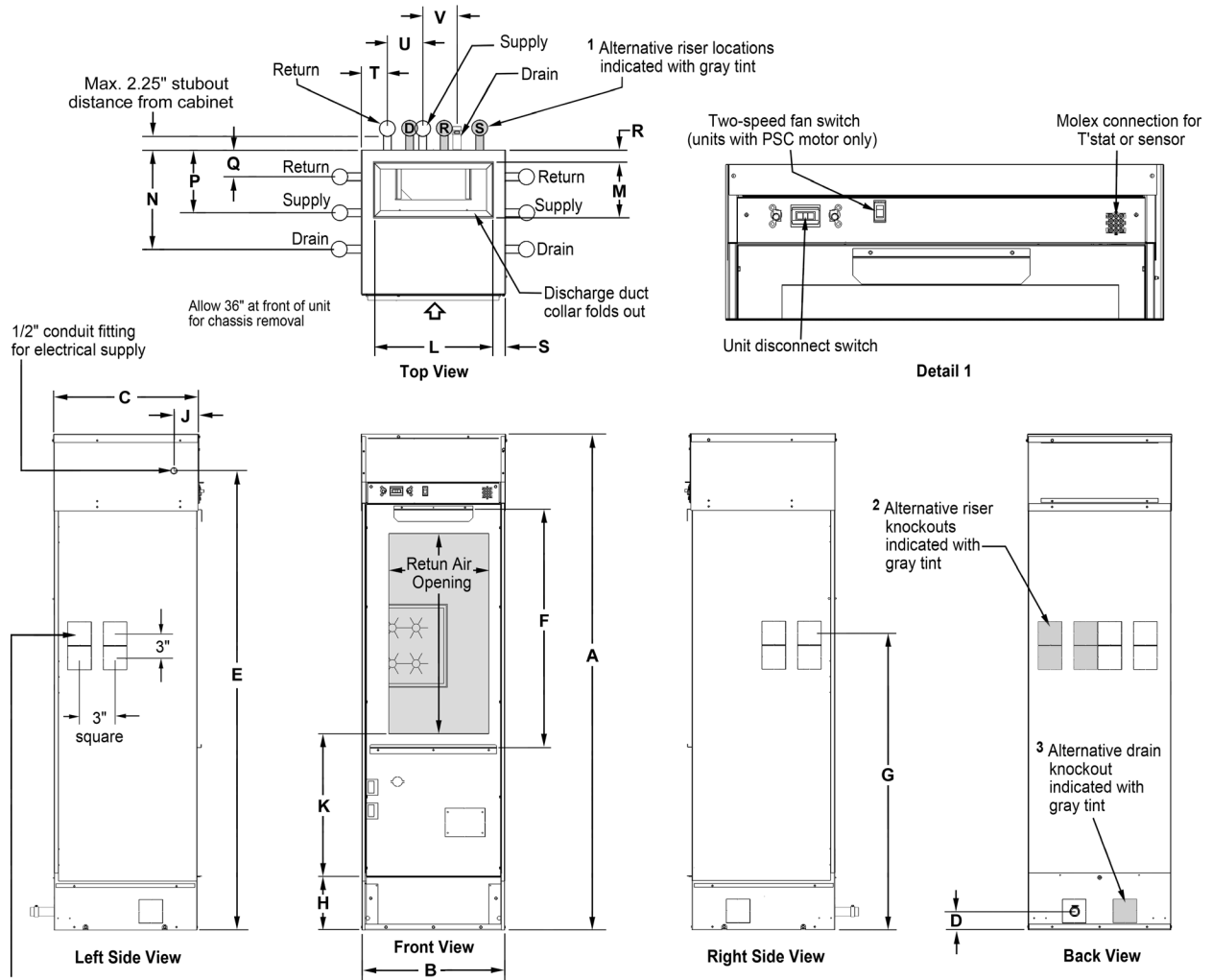

Dimensions

Cabinet											
Cabinet	A ⁴	B	C	D	E	Filter Size	Return Air Opening	G	H	J	K
						F					
18 x 18 (Size 009-012)	62.75	18.00	18.00	2.38	58.08	16"w x 30"h x 1"d	12.62w x 25.25h	37.50	6.72	3.125	24.87
18 x 20 (Size 015-018)			20.00								

Top View											
Cabinet	Discharge Air Opening ⁵		N	P	Q	R	S	T	U	V	
	L	M									
18 x 18 (Size 009-012)	15.00	6.80	12.4	7.9	3.3	1.64	1.64	3.12	4.50	4.50	
18 x 20 (Size 015-018)		8.80									

- NOTE:**
- ¹ Alternative riser locations dimensions mirror those shown as "T", "U", and "V"
 - ² Alternative riser locations for unit sizes 009-018 are field-specified (code 22 = A)
 - ³ Alternative drain location for unit sizes 009-018 is field-specified (code 22 = A)
 - ⁴ Dimension "A" overall cabinet height is 63.5" with discharge duct collar folded out
 - ⁵ Dimensions "L" and "M" are the discharge air opening with the duct collar folded out

Model WSVF 63.5" High Cabinet - Sizes 024-036

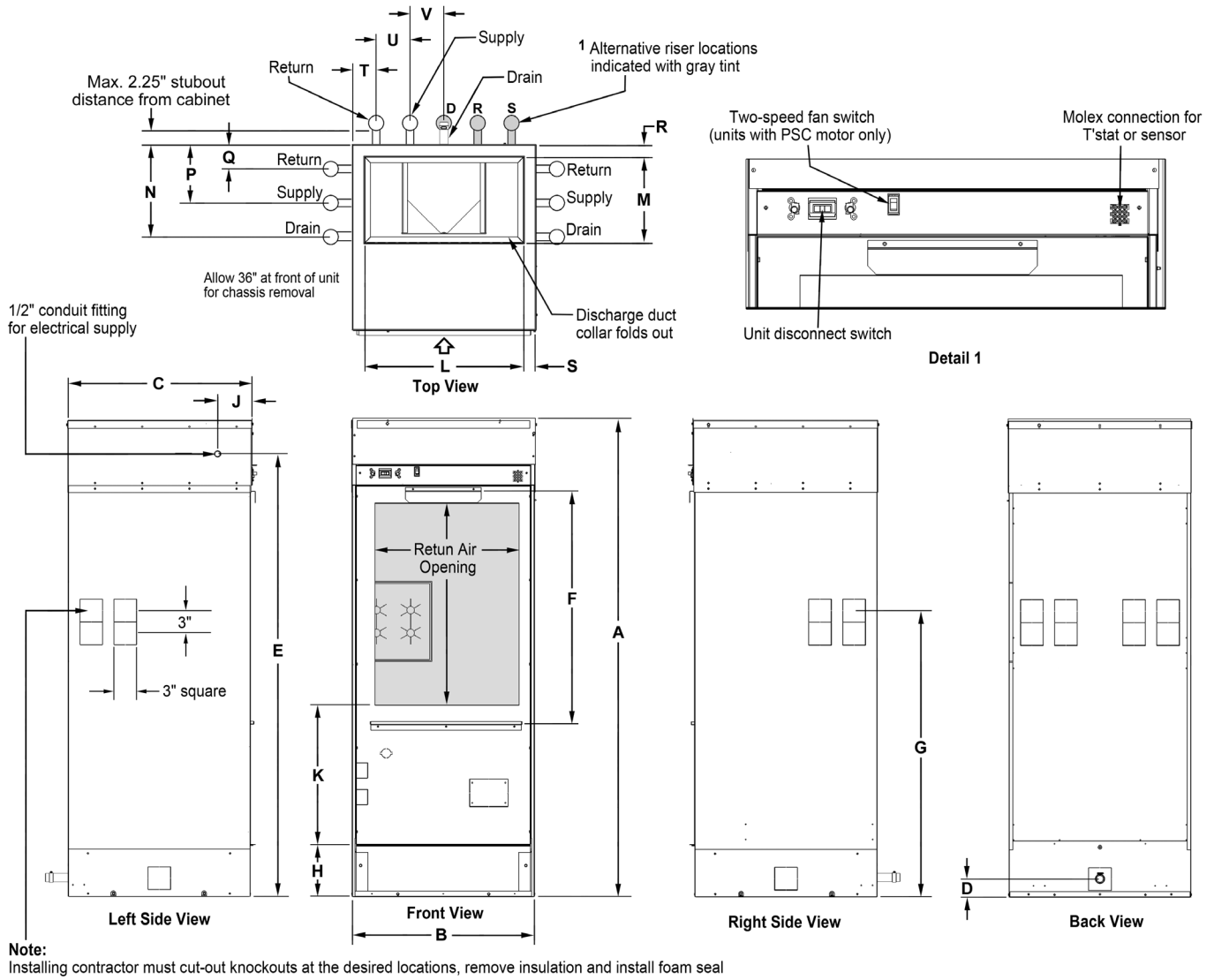

Dimensions

Cabinet											
Cabinet	A ⁴	B	C	D	E	Filter Size	Return Air Opening	G	H	J	K
						F					
24 x 24 (Size 024-036)	62.75	24.00	24.00	2.38	58.08	20"w x 30"h x 1"d	19.00w x 26.50h	37.50	6.72	4.54	25.04

Top View										
Cabinet	Discharge Air Opening ⁵		N	P	Q	R	S	T	U	V
	L	M								
24 x 24 (Size 024-036)	21.00	11.25	12.4	7.9	3.3	1.64	1.64	3.12	4.50	4.50

NOTE: ¹ Alternative riser locations dimensions mirror those shown as "T", "U", and "V". Knockouts are factory provided on unit sizes 024-036.

² Alternative riser locations for unit sizes 009-018 are field-specified (code 22 = A)

³ Alternative drain location for unit sizes 009-018 is field-specified (code 22 = A)

⁴ Dimension "A" overall cabinet height is 63.5" with discharge duct collar folded out

⁵ Dimensions "L" and "M" are the discharge air opening with the duct collar folded out

Figure 13: Typical Framing & Discharge Arrangements

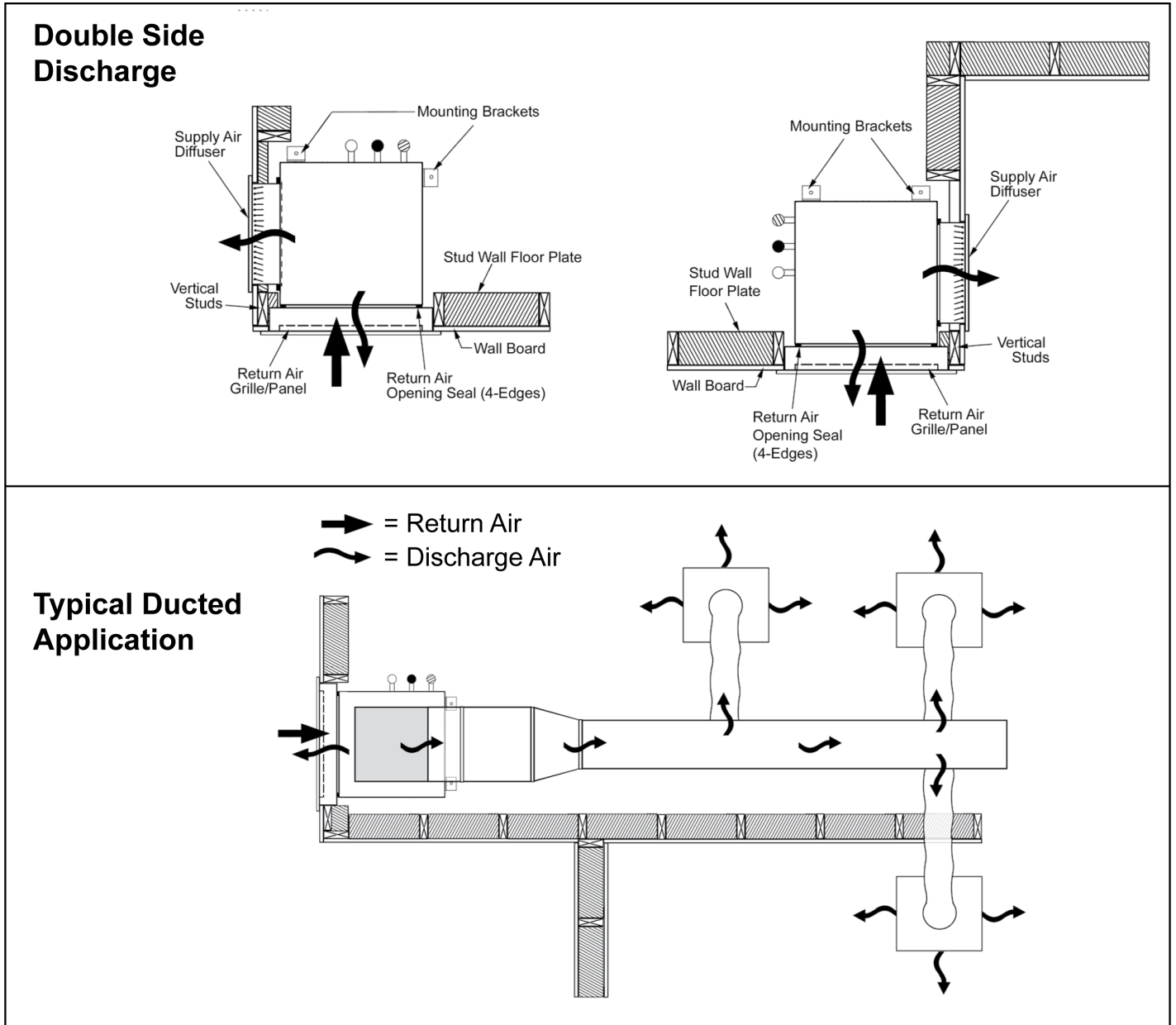

NOTICE
 Top air discharge units will require turning vanes and/or a volume damper for proper air flow and balancing, to minimize turbulence. These components must be field-installed and furnished in accordance with SMACNA guidelines.

NOTICE
 All ducted applications require a unit that utilizes an EC motor.

Dimensions

Framing Locations and Dimensions

Location of framing around unit is critical for proper fit-up and will help reduce sound levels due to the transfer of vibration when properly installed.

Figure 14: Framing Locations and Dimensions

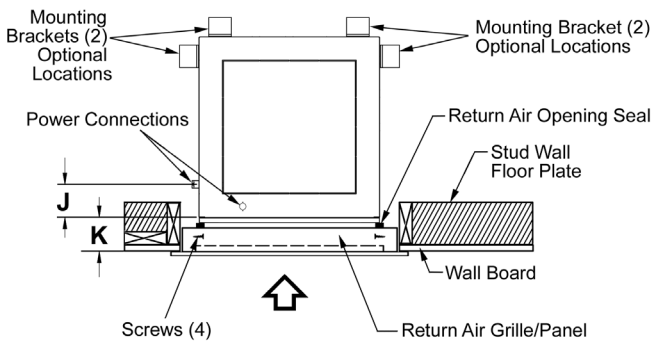
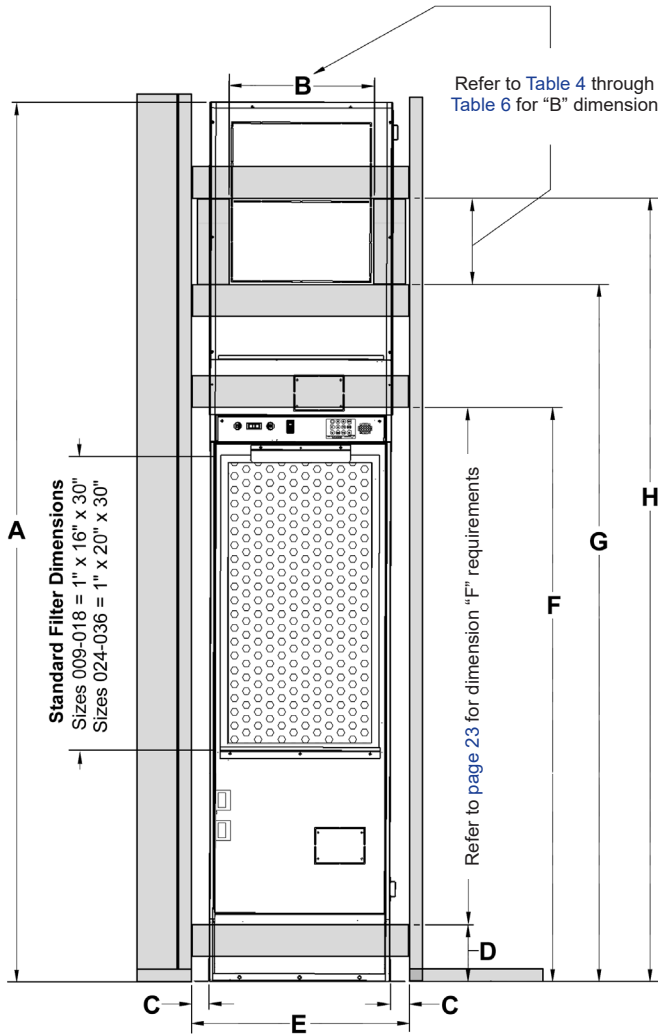

NOTICE

If an optional subbase is used, add its height of either 2", 3", 4" or 5" to the vertical dimensions shown in Figure 14.

Table 4: Letter Dimensions for Figure 14 (18" x 18" Unit)

Dimension	Framing Locations			
	18" x 18" Unit - Sizes 009-012			
	Unit Height "A"			
	80"	88"	92"	96"
B	14"			
C	2.07"			
D	5.75"			
E ¹	22.25"			
F	58.75"			
G ²	60.75"	68.75"	72.75"	76.75"
H ²	78.75"	86.75"	90.75"	94.75"
J	3.125"			
K ^{3,4}	3.125" Min./Max. (See Note ⁴ exception)			

Table 5: Letter Dimensions for Figure 14 (18" x 20" Unit)

Dimension	Framing Locations			
	18" x 20" Unit - Sizes 015 & 018			
	Unit Height "A"			
	80"	88"	92"	96"
B	14"			
C	2.07"			
D	5.75"			
E ¹	22.25"			
F	58.75"			
G ²	60.75"	68.75"	72.75"	76.75"
H ²	78.75"	86.75"	90.75"	94.75"
J	3.125"			
K ^{3,4}	3.125" Min./Max. (See Note ⁴ exception)			

Table 6: Letter Dimensions for Figure 14 (24" x 24" Unit)

Dimension	Framing Locations			
	24" x 24" Unit - Sizes 024-036			
	Unit Height "A"			
	80"	88"	92"	96"
B	18"			
C	2.125"			
D	5.75"			
E ¹	28.25"			
F	58.75"			
G ²	62.75"	70.75"	74.75"	78.75"
H ²	78.75"	86.75"	90.75"	94.75"
J	4.54"			
K ^{3, 4}	3.125" Min./Max. (See Note ⁴ exception)			

Notes: ¹ Dimension "E" \pm 0.125

² Dimension "G" and "H" will vary based on cabinet height selected and choice of upper or lower discharge knockout. Refer to "Dimensions" on page 13 through page 15.

³ Dimension "K" is critical, and that it be no more or no less than 3.125" from the finished wall surface to the front of the unit when using the hinged perimeter return air panel door or the louvered return air panel door. See Note ⁴ for the exception.

⁴ Add 1" to dimension "K" when a 2", Merv 13 filter is used.

Louvered Return Air Panel Door with Optional Motorized Outdoor Air Damper

- Based on the location of the hinges on the ordered louvered panel door, construct the framing to accommodate the ducting for connecting the motorized outdoor air damper. Also refer to "Return Air Panel Door(s) Dimensions" on page 23 for details.

NOTICE

It is the responsibility of the installing contractor to install the ductwork that connects the outdoor air opening in the panel door frame to the source of the outdoor intake opening in the building. All ductwork should conform to industry standards of good practice as described in the ASHRAE Systems Guide. Also refer to good installation practices as outlined in ED 18529.

Figure 15: Louvered Panel Door with Motorized Outdoor Air Damper

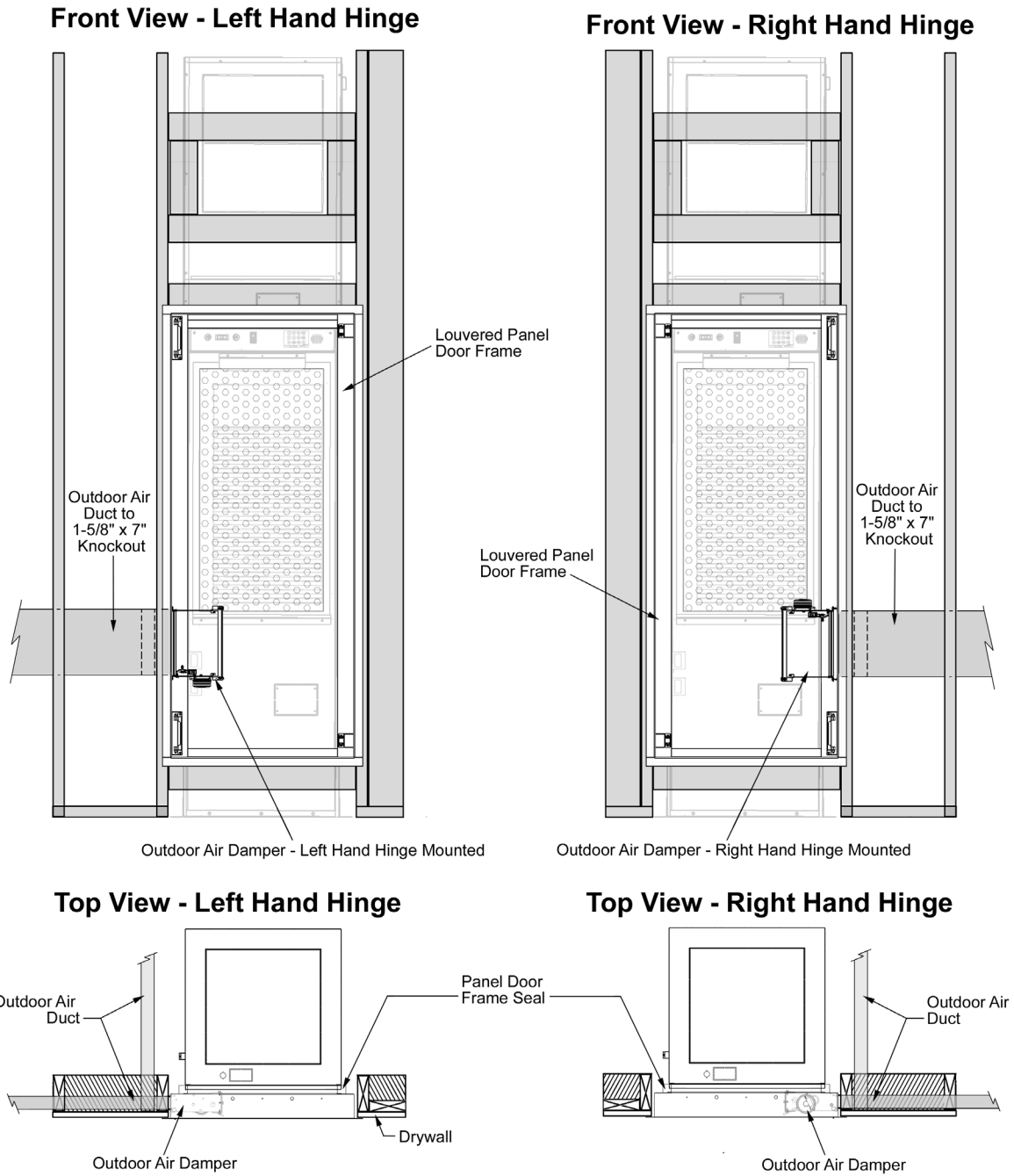

NOTICE

The outdoor air duct can be located on either side of the cabinet and routed around the side- to the back of the cabinet, or run straight- parallel to the front of the cabinet.

Vertical Riser Stub-Outs Locations to Unit Knockouts

Figure 16: Riser Stub-Outs Knockouts Locations

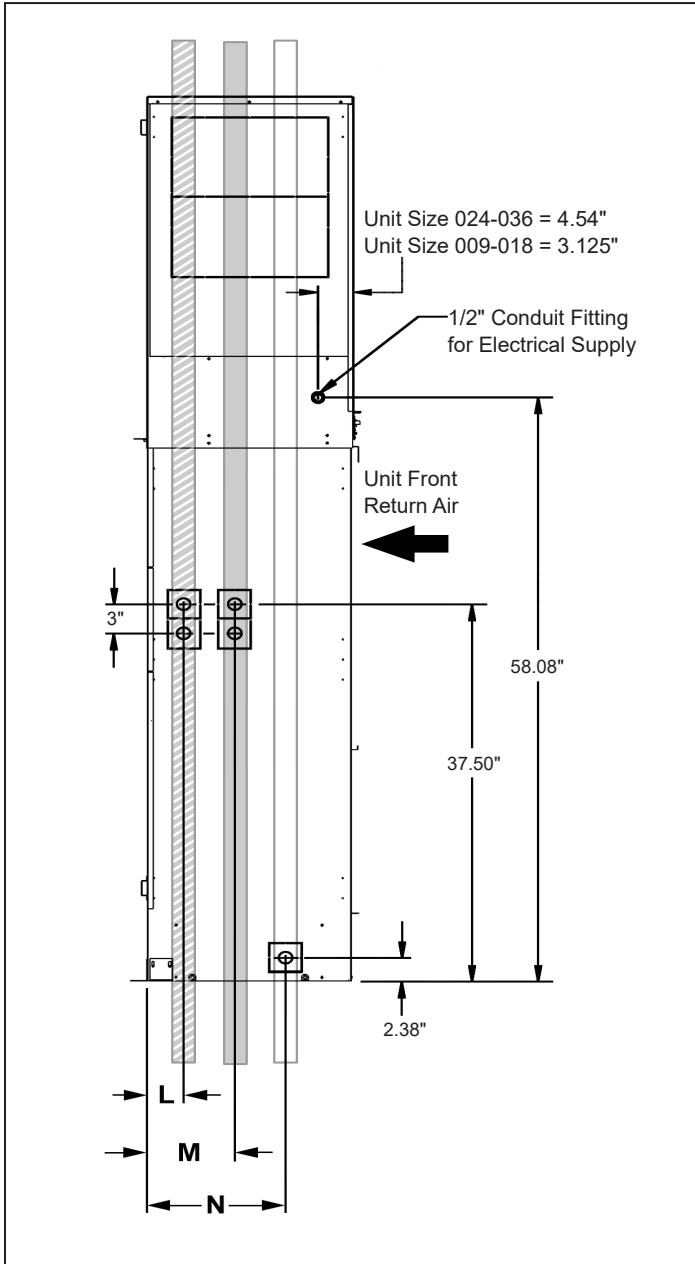

Table 7: Letter Dimensions for Figure 16 (18" x 18" Unit)

Dimension	Riser Stub-Outs Locations				
	18" x 18" Unit - Sizes 009-012				
	Unit Height				
	63.5"	80"	88"	92"	96"
L	3.3"				
M	7.9"				
N	12.4"				

Table 8: Letter Dimensions for Figure 16 (18" x 20" Unit)

Dimension	Riser Stub-Outs Locations				
	18" x 20" Unit - Sizes 015 & 018				
	Unit Height				
	63.5"	80"	88"	92"	96"
L	3.3"				
M	7.9"				
N	12.4"				

Table 9: Letter Dimensions for Figure 16 (24" x 24" Unit)

Dimension	Riser Stub-Outs Locations				
	24" x 24" Unit - Sizes 024-036				
	Unit Height				
	63.5"	80"	88"	92"	96"
L	3.13"				
M	7.63"				
N	12.13"				

Return Air Panel Door(s) Dimensions

Location of studs in relation to the unit and the return air panel door are critical for proper installation and fit up. When installed, the return air grille gasket must compress and seal completely against the outer edge of the cabinet and around the inner front panel and filter bracket. Refer to "Installing the Return Air Panel Door" on page 34 and "Framing Locations and Dimensions" on page 19.

Figure 17: Hinged Panel Door

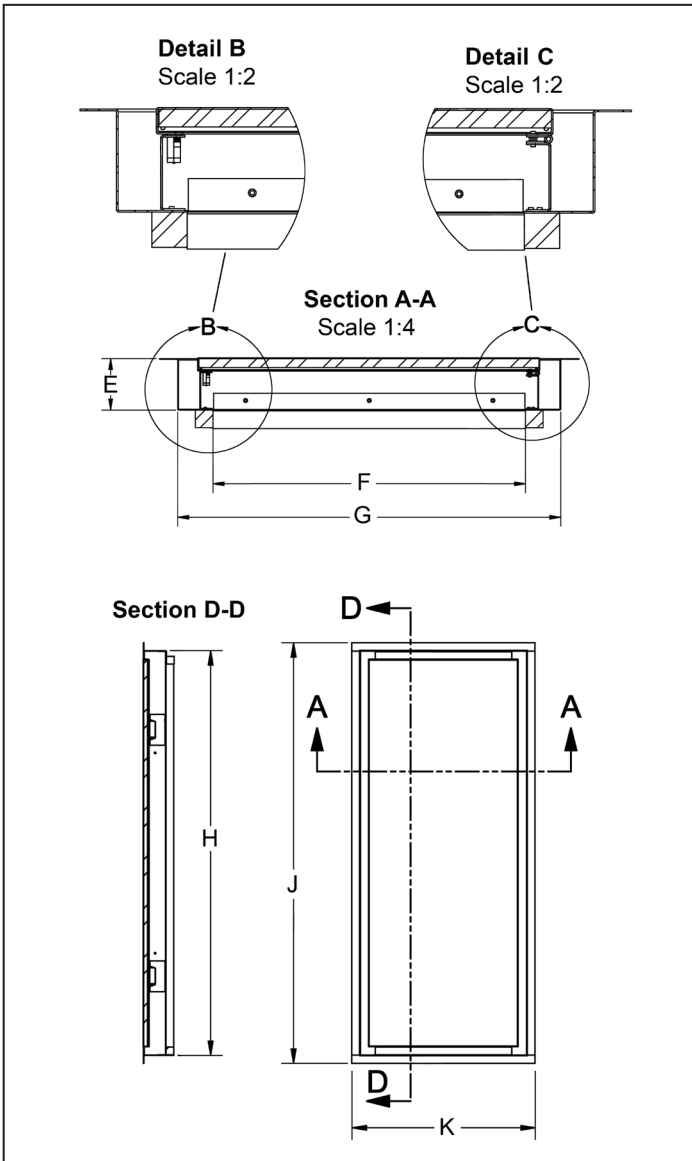
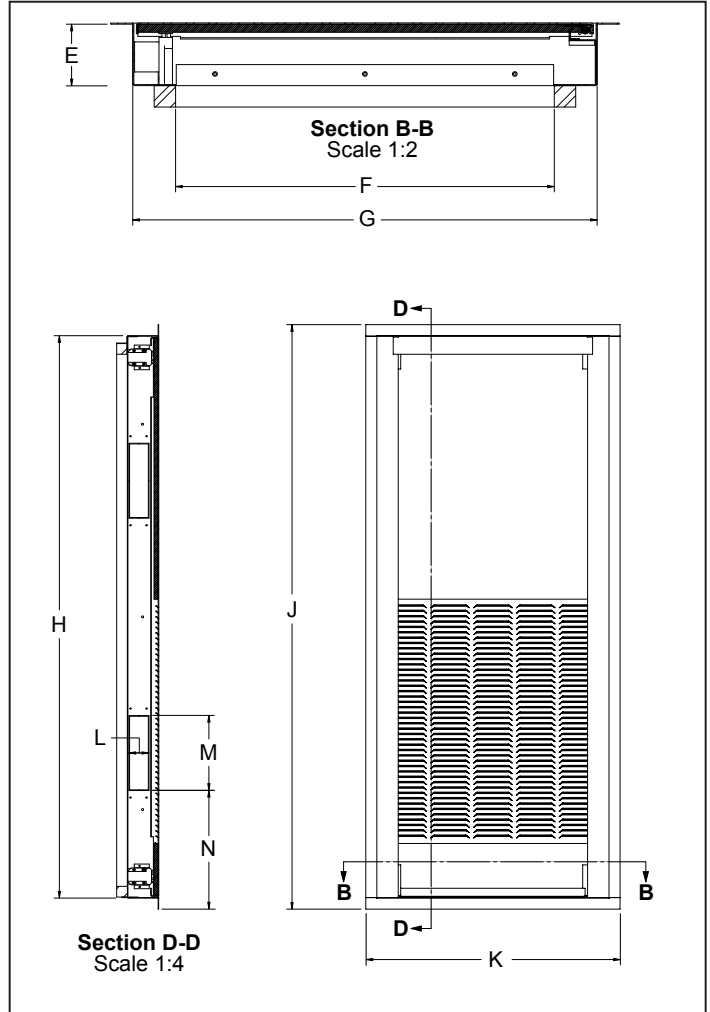

Figure 18: Louvered Panel Door



Dimensions

Unit Size	E		F	G	H	J	K	Outdoor Air Opening		
	1" Filter Compatible Door	2" Filter Compatible Door						L	M	N
009-018	2.92"	3.92"	17.69"	21.69"	52.53"	54.60"	23.75"	1.88"	7.00"	11.08"
024-036			23.69"	27.69"			29.75"			

System Applications

Table 10: Water Quality Conditions & Applications

Potential Problem	Chemical(s) or Condition	Range for Copper Heat Exchangers	Range of Cupronickel Heat Exchanger
Scaling	Calcium & Magnesium Carbonate	Less than 350 ppm	Less than 350 ppm
Corrosion	pH Range	7 – 9	5 – 9
	Total Dissolved Solids	Less than 1000 ppm	Less than 1500 ppm
	Ammonia, Ammonium Hydroxide	Less than 0.5 ppm	Less than 0.5 ppm
	Ammonium Chloride, Ammonium Nitrate	Less than 0.5 ppm	Less than 0.5 ppm
	Calcium Chloride/ Sodium Chloride	Less than 125 ppm	Less than 125 ppm - Note 4
	Chlorine	Less than 0.5 ppm	Less than 0.5 ppm
	Hydrogen Sulfide	None Allowed	None Allowed
Biological Growth	Iron Bacteria	None Allowed	None Allowed
	Iron Oxide	Less than 1 ppm	Less than 1 ppm
Erosion	Suspended Solids	Less than 10 ppm	Less than 10 ppm
	Water Velocity	Less than 8 ft./s	Less than 12 ft./s

NOTE 1: Water hardness in ppm is equivalent to hardness in mg/L.

NOTE 2: Grains/gallon = ppm divided by 17.1.

NOTE 3: Copper and cupronickel heat exchangers are not recommended for pool applications for water outside the range of the table. Secondary heat exchangers are required for applications not meeting the requirements shown above.

NOTE 4: Salt water applications (approximately 25,000 ppm) require secondary heat exchangers due to copper piping between the heat exchanger and the unit fittings.

Water System Quality

The cleaning, flushing and chemical treatment of a water source heat pump system is fundamental to efficient operation and the life expectancy of the system.

Potential system problems produced by the use of water fall into three general categories:

- Scale formation – Mineral deposits which result from the crystallization and precipitation of dissolved salts in the water. The deposits form an insulating barrier, reducing the heat transfer rate and impeding the circulation of fluids due to increased pressure drop.
- Corrosion – Decomposition of the metal caused by absorption of gases from the air. Corrosion may occur in any metal component of the system.
- Organic growths – Slime and algae which form under certain environmental conditions, and can reduce the heat transfer rate by forming an insulating coating or can promote corrosion by pitting.

The system water should be evaluated for degrees of impurity, with testing available from independent testing labs, health departments or state agencies.

Table 10 is a list of water characteristics, the potential impurities and their results and the recommended treatment.

Supply & Return Piping

All units should be connected to supply and return piping in a two-pipe reverse return configuration. A reverse return system is inherently self-balancing and requires only trim balancing where multiple quantities of units with different flow and pressure drop characteristics exist in the same loop.

- To insure proper water flow, measure the temperature differential between the supply and return connections. The temperature differential should be 10°F to 14°F (5°C to 8°C) for units in cooling mode.

A direct return system may also work acceptably, but proper water flow balancing is more difficult to achieve and maintain.

- The piping can be steel or copper.

WARNING

Polyolester Oil, commonly known as POE oil is a synthetic oil used in many refrigeration systems, and may be present in this Daikin Applied product. POE oil, if ever in contact with PVC/CPVC will coat the inside wall of PVC/CPVC pipe causing environmental stress fractures. Although there is no PVC/CPVC piping in this product, please keep this in mind when selecting piping materials for your application, as system failure and property damage could result.

The supply and return stub outs and the factory-provided shutoff valves have male JIC connections and usually join the unit via short lengths of high pressure flexible hose which are sound attenuators for both unit operating noise and hydraulic pumping noise.

- Some flexible hose threaded fittings are supplied with sealant compound. If not, apply Teflon tape to assure a tight seal.

Cleaning and Flushing Water System**CAUTION**

Prior to first operation of any unit, the water circulating system must be cleaned and flushed of all construction dirt and debris or damage will occur.

1. Prior to first operation of any unit, the water circulating system must be cleaned and flushed of all construction dirt and debris.
2. If the units are equipped with water shutoff valves, either electric or pressure operated, the supply and return runouts must be connected together at each unit location. This will prevent the introduction of dirt into the unit.

Figure 19: Connections for Flushing System Piping

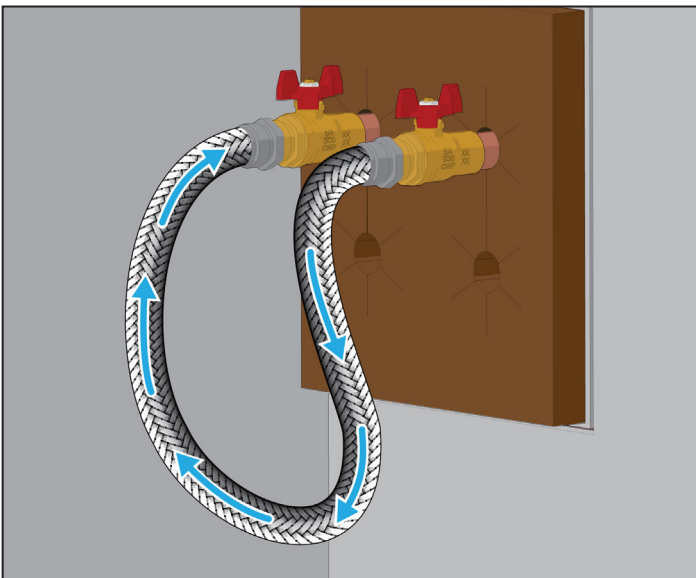

3. Fill the system at the city water makeup connection with all air vents open. After filling, close all air vents. The contractor should start main circulator with the pressure reducing valve open. Check vents in sequence to bleed off any trapped air, ensuring circulation through all components of the system. Power to the heat rejector unit should be off, and the supplementary heat control set at 80°F (27°C).

While circulating water, the contractor should check and repair any leaks in the unit and surrounding piping. Drains at the lowest point(s) in the system should be opened for initial flush and blow-down, making sure city water fill valves are set to make up water at the same rate. Check the pressure gauge at pump suction and manually adjust the makeup to hold the same positive steady pressure both before and after opening the drain valves. Flush should continue for at least two hours or longer until the drain water is clean and clear.

4. Shut off supplemental heater and circulator pump and open all drains and vents to completely drain down the system. Short circuited supply and return runouts should now be connected to the unit supply and return connections. Do not use sealers at the swivel flare connections of hoses.
5. Flush system with water for 2 hours or longer until water is clean.
6. Refill the system with clean water. Test the water using litmus paper for acidity, and treat as required to leave the water slightly alkaline (pH 7.5 to 8.5). The specified percentage of antifreeze may also be added at this time. (See "Antifreeze Correction Factors" on page 26.) Use commercial grade antifreeze designed for HVAC systems only. Do not use automotive grade antifreeze. Once the system has been filled with clean water and antifreeze (if used), precautions should be taken to protect the system from dirty water conditions.

NOTICE

It is not Daikin Applied policy to make recommendations on water treatment. However, the general contractor or owner should contact a local water treatment company regarding water treatment. A fouled closed loop water system will lead to premature component failure.

NOTICE

Contact a local water treatment company to confirm water clarity prior to unit operation. Dirty water will result in system wide degradation of performance and solids may clog system-wide valves, strainers, flow regulators, etc. Additionally, the heat exchanger may become clogged which reduces compressor service life or causes premature failure.

7. Set the loop water controller heat add setpoint to 70°F (21°C) and the heat rejection setpoint to 85°F (29°C). Supply power to all motors and start the circulating pumps. After full flow has been established through all components including the heat rejector (regardless of season) and the vented air and loop temperatures have been stabilized, each of the units will be ready for check, test and start-up, air balancing, and water balancing.

Operating Limits

Environment

This equipment is designed for indoor installation only. Sheltered locations such as attics, garages, etc., generally will not provide sufficient protection against extremes in temperature and/or humidity, and equipment performance, reliability, and service life may be adversely affected.

NOTICE

Altitude Limits: Maximum applied altitude not to exceed 3,000m/9,843ft.

Initial Unit Start-Up Temperature Range

NOTICE

This is not for continuous operation. It is assumed that such a start-up is for the purpose of bringing the building space up to occupancy temperature.

Standard Range Units

Units are designed to start-up in an ambient of 50°F (10°C), with entering air at 50°F (10°C), with entering water at 70°F (21°C), with both air and water flow rates used in the ISO 13256-1 rating test, for initial start-up in winter.

Extended Range Units

Extended range heat pump units are designed to start-up in an ambient of 50°F (10°C), with entering air at 40°F (4°C), with entering water at 25°F (-4°C), with both air and water at flow rates used in the ISO 13256-1 rating test, for initial start-up in winter.

Table 11: Air Limits in °F (°C)

Air Limits	Standard Range Units		Extended Range (Geothermal) Units	
	Cooling (DB/WD)	Heating	Cooling (DB/WD)	Heating
Minimum Ambient Air ¹	50°F (10°C)	50°F (10°C)	40°F (4°C)	40°F (4°C)
Maximum Ambient Air ²	100°F/77°F (38°C/25°C)	85°F (29°C)	100°F/77°F (38°C/25°C)	85°F (29°C)
Minimum Entering Air ¹	65°F/55°F (18°C/13°C)	50°F (10°C)	65°F/55°F (18°C/13°C)	50°F (10°C)
Common Design Entering Air	75°F/63°F (24°C/17°C)	70°F (21°C)	75°F/63°F (24°C/17°C)	70°F (21°C)
Maximum Entering Air ²	85°F/71°F (29°C/22°C)	80°F (27°C)	85°F/71°F (29°C/22°C)	80°F (27°C)

¹ Maximum and minimum values may not be combined. If one value is at maximum or minimum, the other conditions may not exceed the normal condition for standard units. Extended range units may combine any two maximum conditions, but not more than two, with all other conditions being normal conditions.

² This is not for continuous operation. It is assumed that such a start-up is for the purpose of bringing the building space up to occupancy temperature.

Table 12: Fluid Limits in °F (°C)

Air Limits	Standard Range Units		Extended Range Units	
	Cooling	Heating	Cooling	Heating
Minimum Entering Fluid	55°F (13°C)	55°F (13°C)	30°F (-1°C)	25°F (-4°C)
Common Design Entering Fluid	85°F-90°F (29°C-32°C)	70°F (21°C)	77°F (25°C)	35°F-60°F (1.5°C-16°C)
Maximum Entering Fluid	120°F (49°C)	90°F (32°C)	120°F (49°C)	90°F (32°C)
Minimum GPM/Ton	2.0			
Nominal GPM/Ton	3.0			
Maximum GPM/Ton	4.0			

Antifreeze Correction Factors

Glycol Solutions

The use of glycol may impact system performance depending on its concentration and should be considered during initial system design. When glycol is added to the water system for freeze protection, recognize that the refrigerant suction pressure will be lower, capacity will be less, and water side pressure drop will be higher. The reduction in performance depends upon the glycol concentration and temperature.

CAUTION

Do not use an automotive-grade antifreeze. Industrial grade glycols must be used. Automotive antifreeze contains inhibitors which will cause plating on the copper tubes within the chiller evaporator. The type and handling of glycol used must be consistent with local codes.

Table 13: Antifreeze Correction Factors

Ethylene glycol					
	10%	20%	30%	40%	50%
Cooling Capacity	0.995	0.992	0.987	0.983	0.979
Heating Capacity	0.991	0.982	0.977	0.969	0.961
Pressure Drop	1.07	1.13	1.18	1.26	1.28
Propylene glycol					
	10%	20%	30%	40%	50%
Cooling Capacity	0.99	0.98	0.97	0.96	0.95
Heating Capacity	0.987	0.975	0.962	0.942	0.93
Pressure Drop	1.07	1.15	1.25	1.37	1.42
Ethanol					
	10%	20%	30%	40%	50%
Cooling Capacity	0.9910	0.9510	-	-	-
Heating Capacity	0.9950	0.9600	-	-	-
Pressure Drop	1.035	0.96	-	-	-
Methanol					
	10%	20%	30%	40%	50%
Cooling Capacity	0.998	0.972	-	-	-
Heating Capacity	0.995	0.97	-	-	-
Pressure Drop	1.023	1.057	-	-	-

NOTE: Higher percentage mixtures of ethanol and methanol are not recommended due to increased flammability.

Installation

This equipment is designed for indoor installation only. Sheltered locations such as attics, garages, etc., generally will not provide sufficient protection against extremes in temperature and/or humidity, and equipment performance, reliability, and service life may be adversely affected.

CAUTION
Units must be checked for water leaks upon initial water system start-up. Water leaks may be a result of mishandling or damage during shipping. Failure by the installing contractor to check for leaks upon start-up of the water system could result in property damage.

CAUTION
Installation and maintenance is to be performed only by qualified personnel who are familiar with, and in compliance with state, local and national codes and regulations, and experienced with this type of equipment. Sharp edges and coil surfaces are potential injury hazards. Avoid contact with them.

Risers and Cabinet

1. Position the cabinet and risers within the building pipe chase and align with the unit on the floor above and/or below (Figure 20).

NOTICE
The cabinet must be centered between the wall studs and plumb vertically for the grille/panel frame and diffuser to properly align and seal to the cabinet. Use of a 4' level is recommended.

NOTICE
Refer to Figure 22 to determine the correct recess depth from the front of the unit to the drywall face. When the installation is complete, the return air grille/panel frame must meet to seal with the cabinet discharge opening and the discharge air diffuser duct must meet and seal with the discharge opening.

2. Using the riser extensions, make preliminary riser connections between the units above and or below to assure proper riser alignment (supply, return and condensate). Figure 20.
3. After all components are aligned properly, anchor the unit cabinet to the floor using the Daikin Applied provided mounting brackets, as illustrated in Figure 21.
4. Locate the two mounting brackets in the parts bag and position them near the back corners of the unit, or one on a side and one on the back, whichever location or combination is most suitable. See Figure 21 and Figure 22. Contractor is responsible for the appropriate fasteners to secure the brackets to the floor, as local codes dictate.

Figure 20: Position the Cabinet and Risers

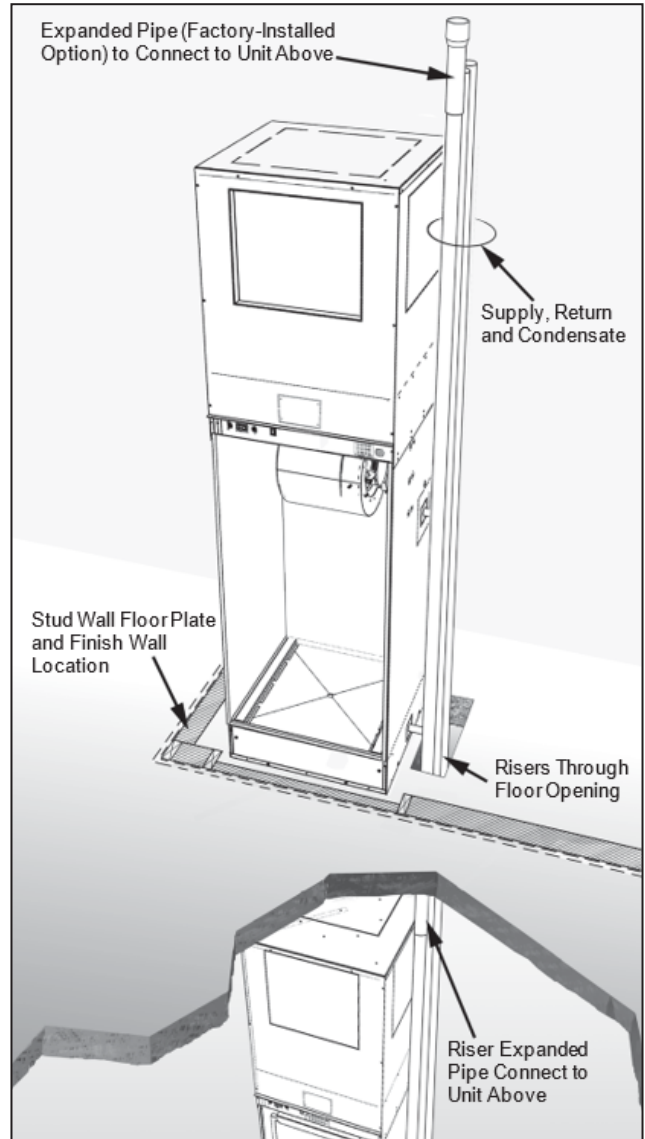

Figure 21: Provided Mounting Brackets

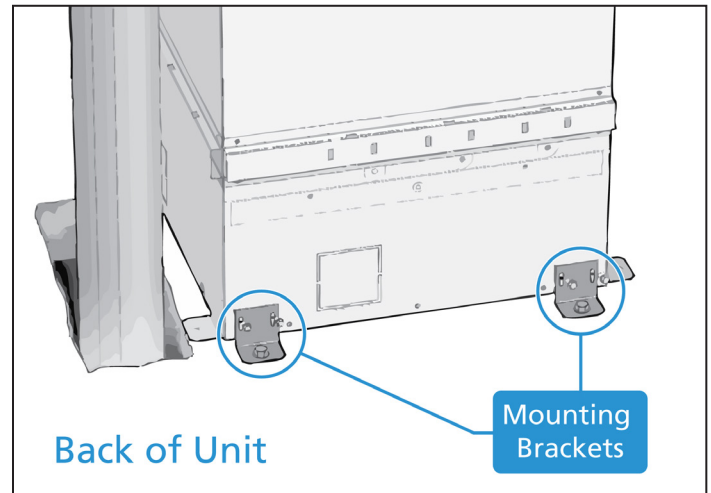
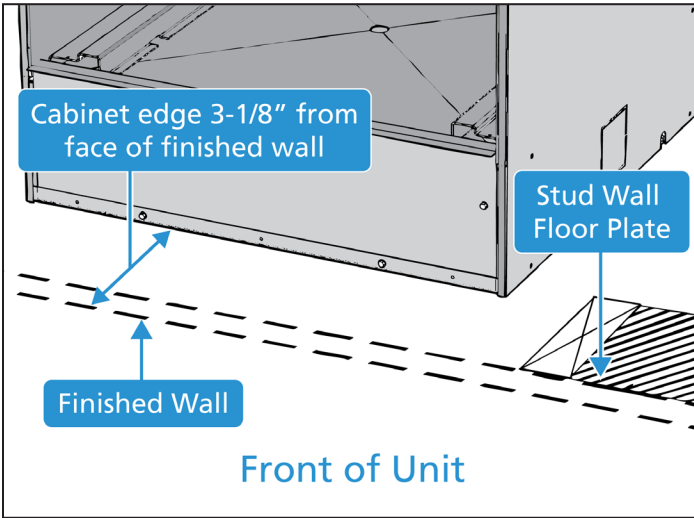

Figure 22: Critical Dimension - Cabinet Edge



NOTICE

Add 1" to dimension when a 2", Merv 13 filter is used.

NOTICE

Apply the provided seal to the interior of the cabinet around the stub-outs. Be sure there are no voids between the stub-outs and the stub-out seal which helps prevent air infiltration into the cabinet.

Figure 23: Riser Knockouts - Cabinet Exterior

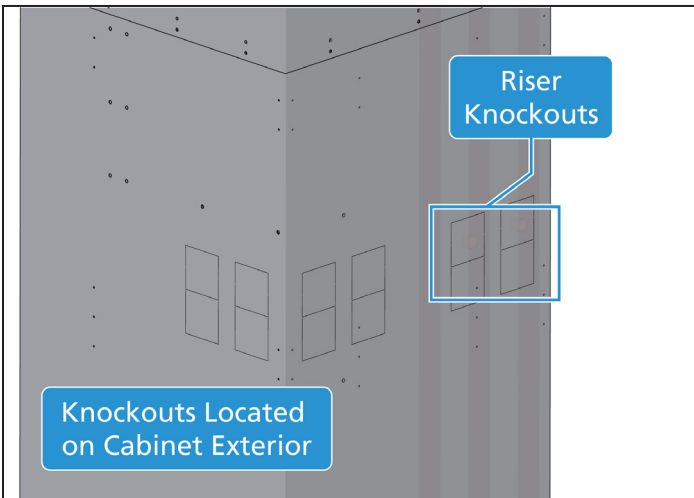

CAUTION

The unit is not designed to support the weight of the risers. Anchor them securely to the building structure.

- Center the riser stub-outs within the knockouts and apply provided seal to the cabinet interior, as shown in Figure 24.

Figure 24: Stub-Out Seal (Field Installed)

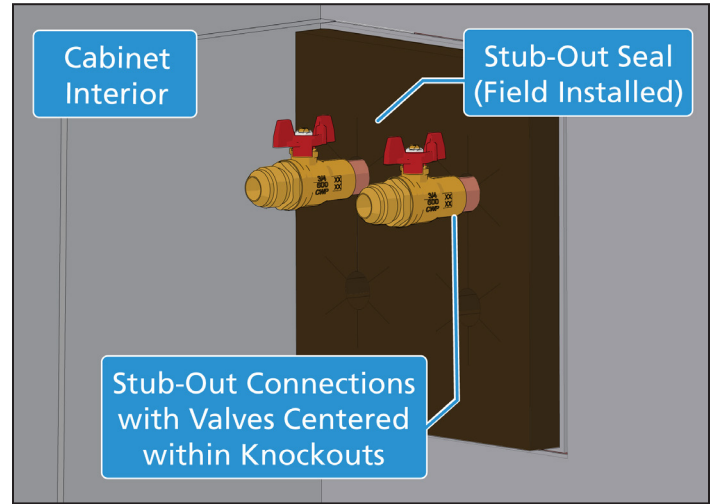

- Anchor risers to the building structure to prevent vertical riser movement greater than, plus or minus one inch to allow for riser expansion or contraction.
- Solder all supply and return riser connections to units above and/or below.
- Remove riser ties used to secure the risers to the cabinet during shipping.

WARNING

Before furring-in units, conduct hydrostatic testing of the risers and unit connection joints in accordance with local building codes to make sure they are leak-proof.

NOTICE

Perform "Cleaning and Flushing Water System" on page 25.

CAUTION

When furring-in units, make sure that no screws or nails penetrate the unit cabinet.

- Layout the stud wall floor plates and frame-in unit. See Figure 13 on page 18 and Figure 14 on page 19.

NOTICE

Before cutting and hanging drywall, remove the appropriate discharge air opening knockout (see Table 14). Protect unit from construction debris with a protective cover.

Table 14: Discharge Knockout Openings

Unit Size	Discharge Openings							
	Single		Double		Triple		Single-Top Opening	
	W	H	W	H	W	H	W	H
009-012	14"	16"	14"	8"	NR	NR	12"	12"
015-018	14"	16"	14"	8"	14"	8"	12"	12"
024-036	NR	NR	18"	14"	18"	10"	18"	18"

NR = Not Recommended

Power Wiring from Building to Unit

⚠ DANGER

To avoid electrical shock, personal injury, or death:

1. Installer must be qualified, experienced technician.
2. Disconnect power supply before installation to prevent electrical shock and damage to equipment.

1. Locate the electrical power supply wiring from the building and feed wiring through a field-provided 1/2" conduit fitting (strain relief), on the unit as shown in [Figure 25](#) & [Figure 26](#), following local electrical codes and regulations.

Figure 25: Supply Electric Wiring from Building to Unit

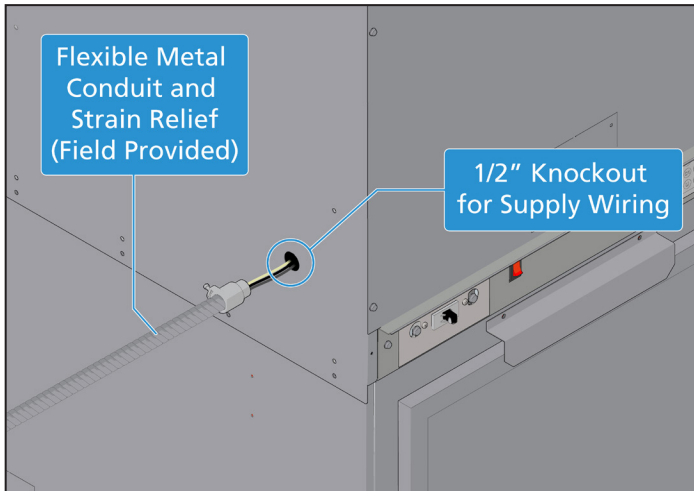
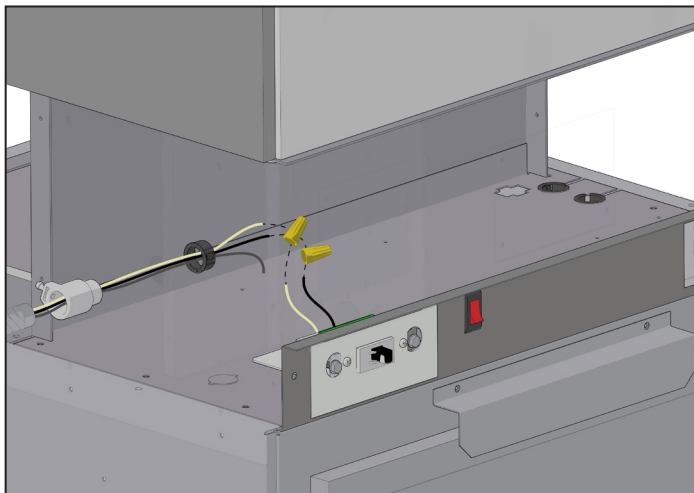
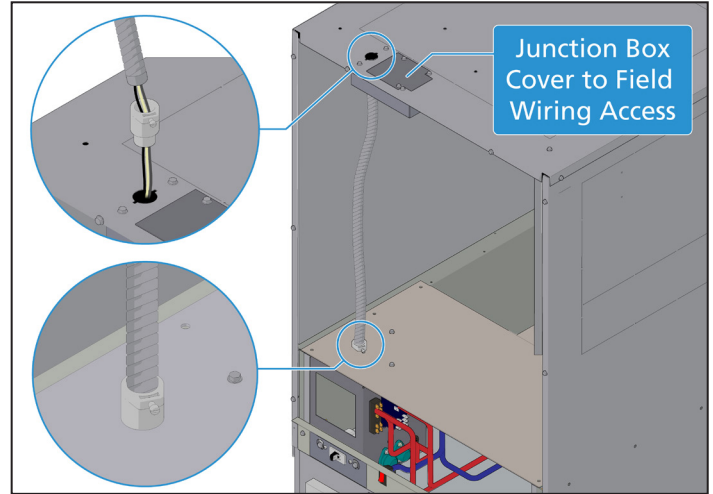

Figure 26: Wire to Unit Switch



Electrical Entry Through Top

Figure 27: Power Wiring Through Top Entry



2. If a remote wall-mounted thermostat is being used, install it referring to the installation manual that came with the thermostat. Route the wires and male moxex plug to the unit mounted moxex receptacle located on the face plate of the unit. Secure the wires in compliance with local codes. Plug in the 12-pin moxex plug noting the position of the locating rib as a reference. See [Table 15](#) on page 30.

Figure 28: Plug 12-Pin Moxex with Wire Whips into the Moxex Receptacle

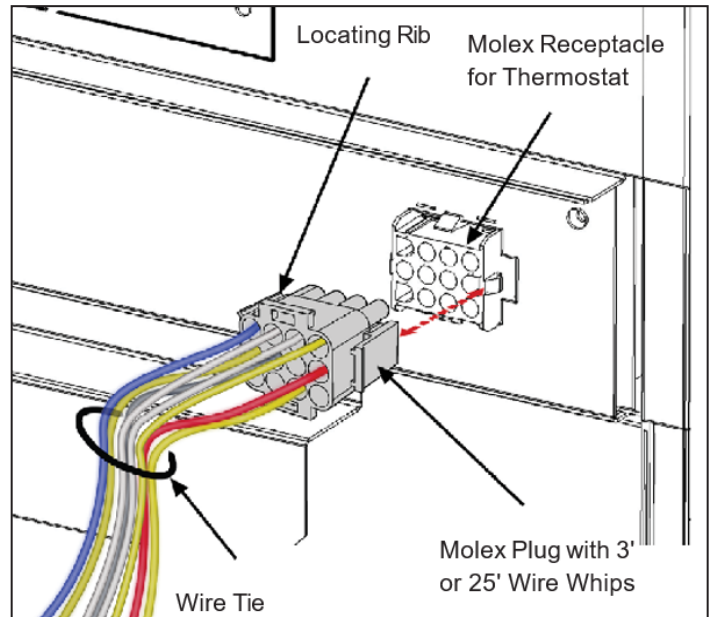

NOTICE

Before enclosing the unit with drywall, install the 3.25" deep diffuser extension frame to the unit discharge air opening. See "Installing The 3.25" Deep (2-Piece) Discharge Air Diffuser" on page 36. Note that the louvered discharge air diffuser will slide into and connect to the extension frame and secured after the unit has been framed-in and the discharge opening is cut out of drywall.

Table 15: Thermostat Molex Plug

Molex Plug		Thermostat
Wire Color	Wire No.	Termination Point
BLU	1	R
WHT	2	W2
WHT	3	W1
YEL	4	Y2
YEL	5	Y1
GRY	6	G
RED	8	A
YEL	11	C

Table 16: Room Sensor Molex Plug for Use on Units with BACnet Communications

Molex Plug		MicroTech
Wire Color	Wire No.	Termination Point
BLU	1	LED
WHT	2	FM
WHT	3	SP
YEL	4	RM
YEL	5	GND
GRY	6	MS/TP+
YEL	7	MS/TP-
RED	8	MS/TP REF
PNK	9	E
BRO	10	U

Typical Connections for Thermostats & Temperature Sensors Applications

Figure 29: Wiring Example of Typical Heat/Cool Thermostat Connections

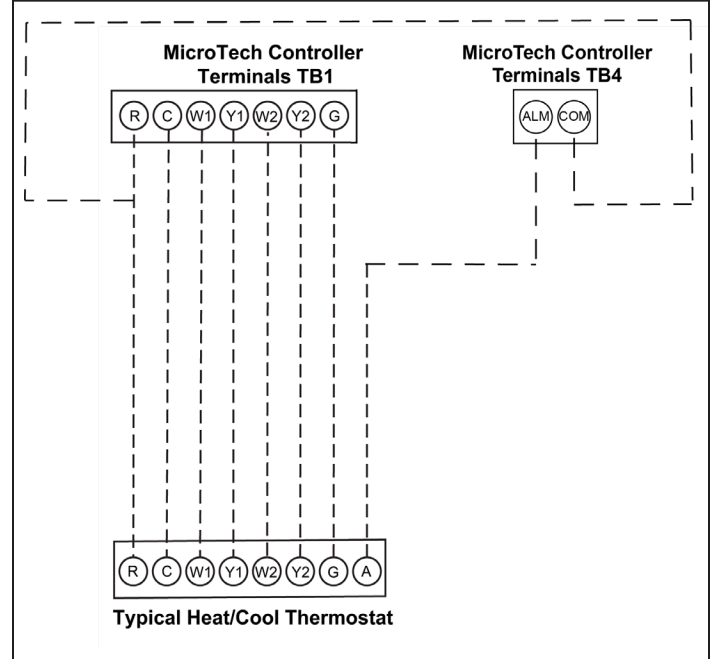

NOTE: For single stage operation wire Y1 from thermostat to Y2 terminal on the MicroTech control board.

Sensors Used With Vertical Stack Units – Building Automated System (BAS) Operation – Wiring

Figure 30: Basic Sensor – P/N 669529001

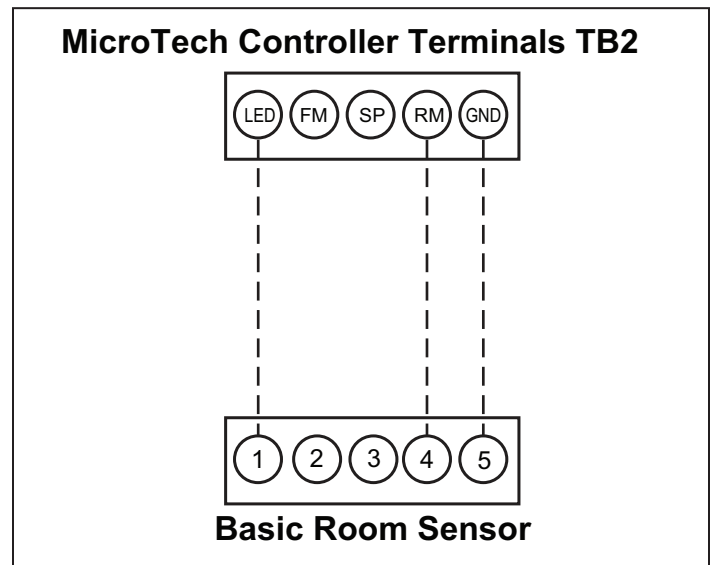

Figure 31: Example Wiring of SmartSource MicroTech Board to Basic Temperature Sensor Wiring

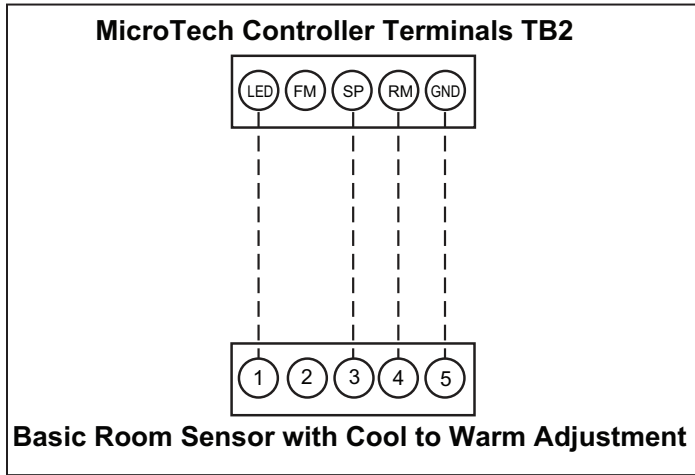
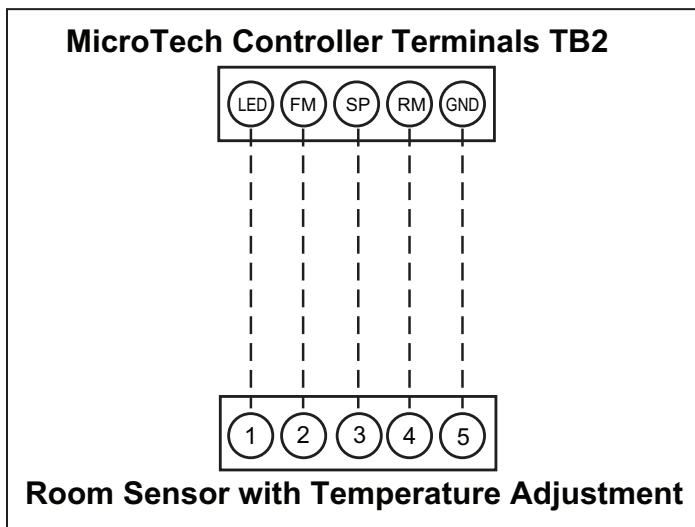

Figure 32: Room Sensor with Temperature Adjustment Wiring



Drain Hose Connections

To connect the condensate drain hose to the field-supplied or factory-provided (shipped loose) drain stub-out, do the following:

NOTICE

For shipped loose or field supplied risers by others, the condensate hose connection is dependent on riser location and must be field adjusted. For a drain riser located at the back of the unit the factory provided drain hose can be connected (as is) to the drain stub out. Right or left hand drain hose connections will require the drain tube be cut at the indicated cut line on the drain tube, (units sizes 009 - 018 only).

1. Remove the two screws located along the back edge of the drain pan, holding it in place (Figure 33).
2. Cut the drain tube to the appropriate length for a right or left hand drain connection (units sizes 009 - 018 only). If

connecting the drain tube to the drain stub-out at the back of the unit, cutting the drain tube may not be necessary.

3. Connect the condensate drain hose to the drain stub-out. Using the provided clamp, secure the hose by tightening the clamp.

CAUTION

Be sure that there are no kinks, bends or restrictions in the drain tube, but that it is straight with a slight down-pitch between the J-trap and clamp.

4. Reinstall the secondary drain pan with the two screws removed in step 1.

Figure 33: Drain Pan Screw Removal

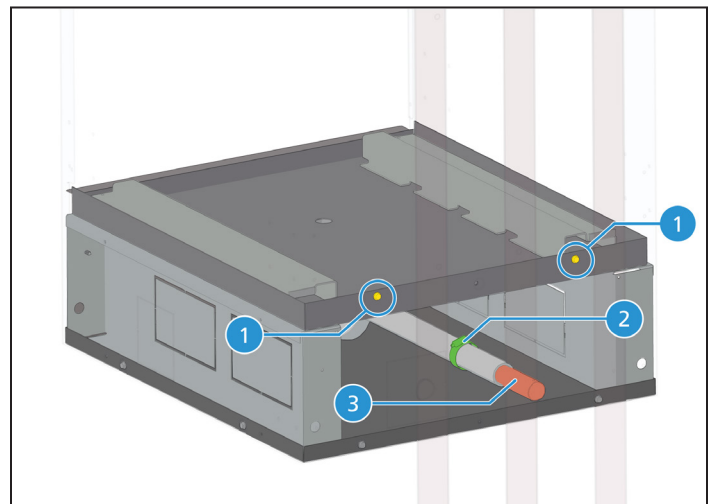

No	Component
1	Drain Pan Screws
2	Clamp
3	Drain Stub-Out

Figure 34: Drain Tube Cut Location

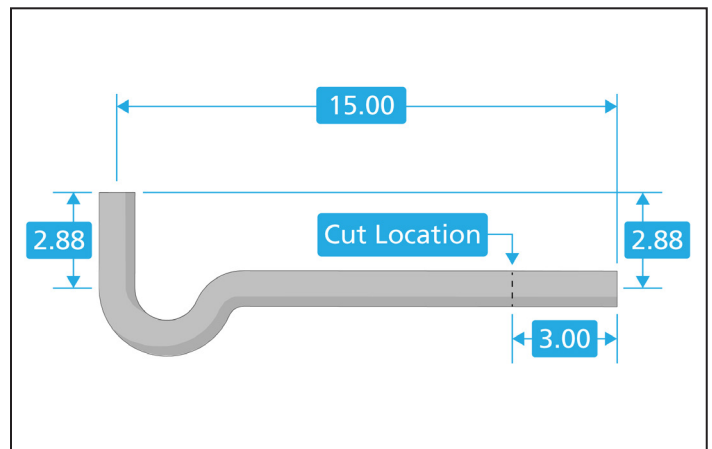

Water Connections

All piping connections should be made using good plumbing practices and in accordance with any and all local codes that may apply.

Unit Piping Connection

Unit sizes 009 through 018 coil connections are gooseneck style, made of copper tubing with 1/2" male JIC. Unit sizes 024 through 036 have 3/4" male JIC connections.

Shutoff/Balancing Valve

Each heat pump requires a flexible hose with a shutoff valve on both the supply and return stubouts for easy serviceability and removal of the chassis when necessary.

Daikin Applied recommends a factory installed 2-way motorized isolation valve on the return line of the chassis and an Auto Flow Regulator (AFR) installed on the supply line which allows proper water flow in a given size unit. Each valve package has 1/2" JIC or 3/4" JIC threaded connections.

Figure 35: Typical Motorized Valve Piping

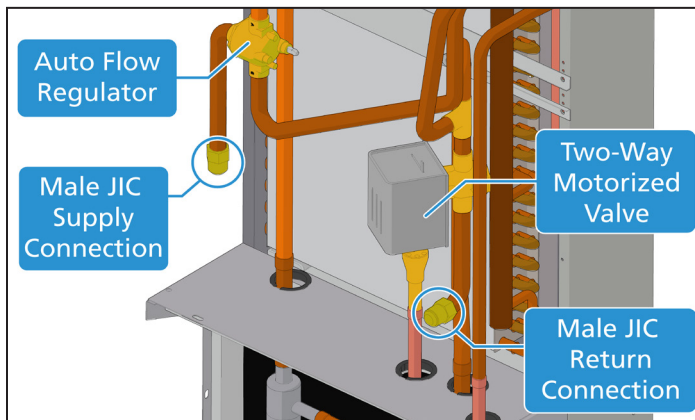

Motorized Valve & Auto Flow Regulator

The Vertical stack water source heat pump chassis can be configured with a 2-way motorized valve. The 2-way motorized valve is mounted on the return line of each unit and the Auto Flow Regulator (AFR) is mounted to the supply line.

Flexible Hose Connections to the Supply and Return Valves from Riser Stub-Outs

- Using the specified supply and return hoses, make supply and return hose connections to the riser stub-outs valve connections.
- Attach one end of the JIC swivel hose end to the male JIC connection on the supply and return stub out valves. Using two crescent wrenches, one to hold the valve and the second on the hose end, tighten the connections.

Figure 36: Supply and Return Hose Connections

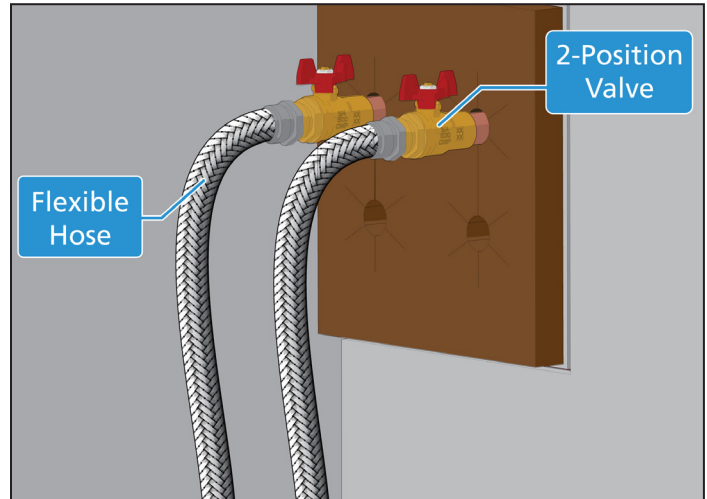

NOTICE

To complete the flexible hose connections to the chassis, only partially install the chassis into the cabinet as shown in Figure 39.

Figure 37: Hose Kits (Sizes 009-018)

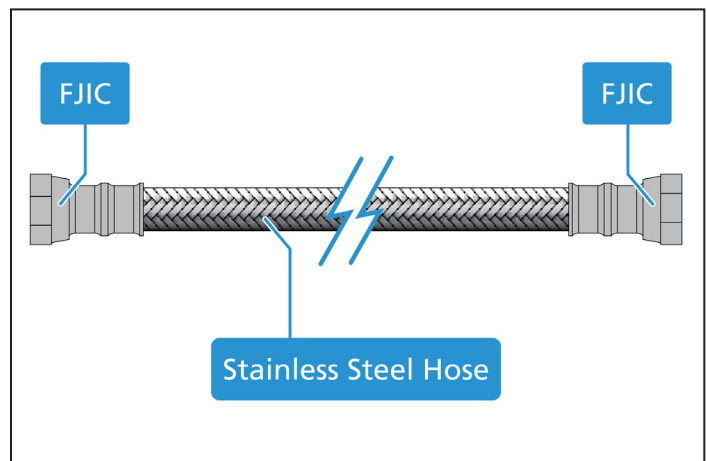

Chassis Handling Guidelines

NOTICE

If using a hand truck to move chassis, tip the chassis forward or back only, pivoting on the ends of the chassis rails. Tipping and pivoting the chassis side-to-side on the long edge of the rails will damage the rails and the rubber vibration isolators.

CAUTION

To avoid personal injury, protective gloves should be used while moving and lifting the unit chassis.

When handling and moving the chassis, tip front to back only, pivoting on the ends of the rails as shown in Figure 38. Do not tip the chassis from side to side on the long edge of the rail or damage will occur.

Figure 38: Tipping the Chassis

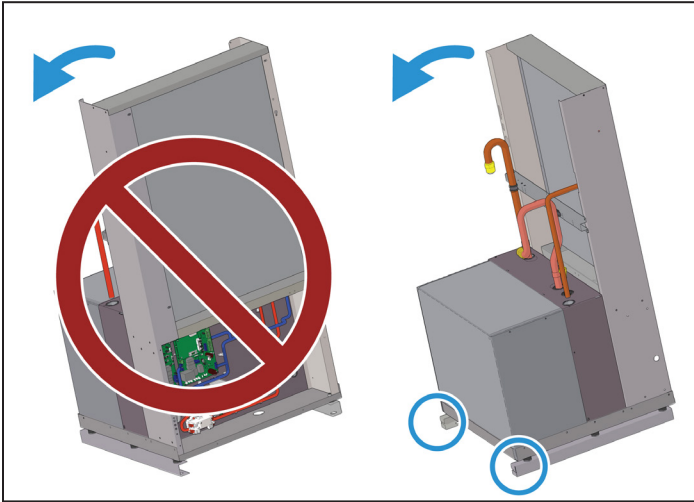

Installing Unit Chassis

1. Install the chassis by sliding it into the cabinet opening until the chassis support rails sit on the cabinet rails. Slide the chassis into the cabinet until there is approximately a 10" space between the chassis coil and the cabinet. This will allow adequate clearance to connect the flexible hoses to the chassis coil. For safety, place a 6" high block under the chassis rails to support the chassis as shown in [Figure 39](#).

Figure 39: Slide Chassis Partially into the Unit Cabinet

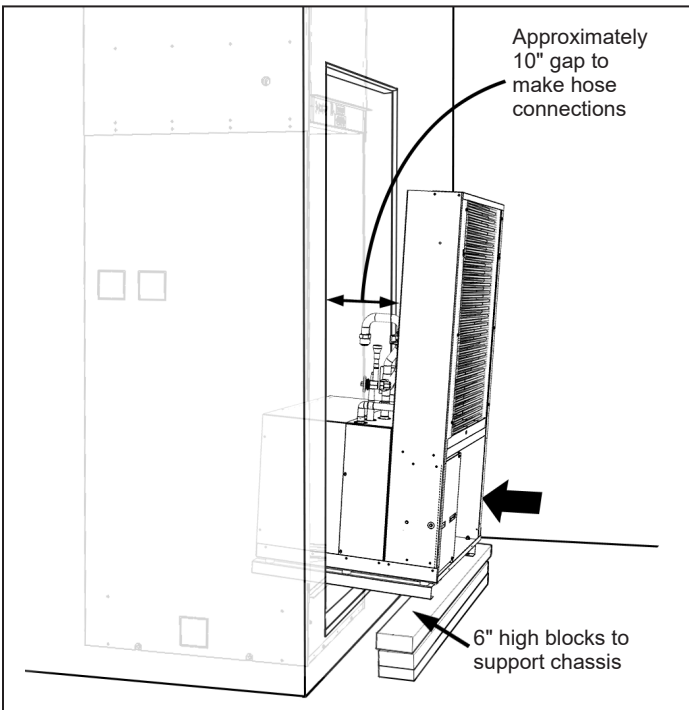

2. Thread the female swivel ends of the hoses on to the water supply and return connections. Using two crescent wrenches, one to hold the chassis pipe fitting connection and the second on the flexible hose swivel, tighten the connections. See [Figure 40](#).

Figure 40: Leave 10" Gap for Clearance To Make Flexible Hose Connections

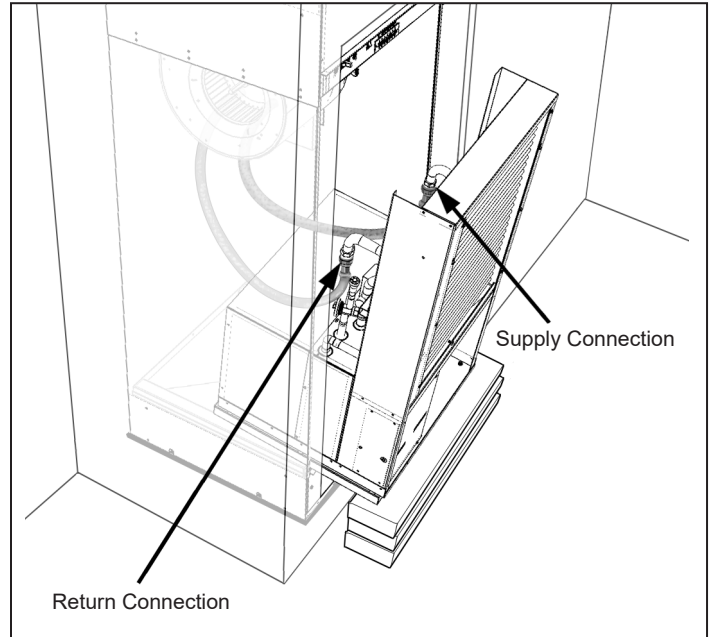

Making Cabinet to Chassis Wiring Connections

⚠ DANGER

To avoid electrical shock, personal injury, or death:

1. Installer must be qualified, experienced technician.
2. Disconnect power supply before installation to prevent electrical shock and damage to equipment.

1. Locate the wires and plugs in the upper fan section of the unit that connect to the unit chassis.
2. Plug in the wires from the top cabinet section into the proper molex receptacle on the chassis. See [Figure 41](#).
3. Push the chassis into the cabinet until it makes contact with the stops on the rails at the rear of the cabinet.

NOTICE

Be sure there are no kinks and that the stainless steel braided hoses do not come in contact with and vibrate on chassis and cause noise. Also be sure not to pinch wires between cabinet and chassis when inserting chassis.

Figure 41: Plug Unit Component Wiring from the Top Cabinet Section into the Proper Receptacle on the Chassis

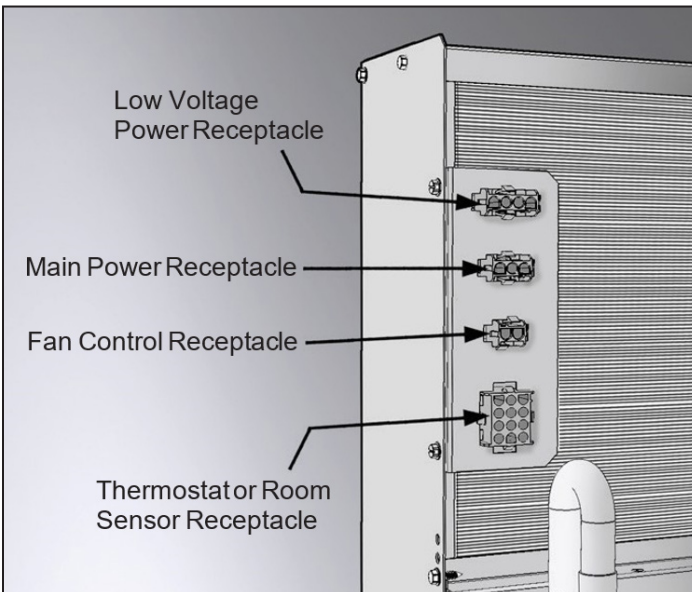

NOTE: Unit size 015 chassis shown.

Installing the Return Air Panel Door

1. Install the return air panel door assembly ([Figure 42](#)). Center, level and plumb the frame inside the framed opening. Push the assembly into the opening until the gaskets compress against the cabinet, and the frame face is tight to the finished wall.

NOTICE

Shims (field-supplied) should be used to make up the space between the studs and the panel frame at the locations of the fasteners on the panel frame. Adhere them to the panel frame to keep them in place ([Figure 42](#)).

NOTICE

Be sure the bottom flange of the door frame slides beneath the cabinet flange, as shown in [Figure 42](#). This seal must compress between the bottom panel flange and the bottom cabinet flange when the installation of the panel door frame is complete.

2. Check that the panel door frame is centered within the opening and seals completely to the cabinet return air opening. Also confirm that the room side flange of the frame is level, plumb and firmly against the drywall. Secure the hinged panel door frame with the appropriate fasteners/screws (field provided).

NOTICE

Before proceeding to step 3, be sure to clean frame with rubbing alcohol to remove any oils or dust to ensure a strong bond between Velcro® and door frame.

3. Remove the backing on the (hook) Velcro® strips and firmly press the cover plate to the panel door frame in the location shown in [Figure 42](#).

NOTICE

The clearance holes along the top edge of the cover plate should fit around the screws on the underside of the top door frame.

Figure 42: Installing the Return Air Panel Door (Hinged Perimeter Panel Door Shown)

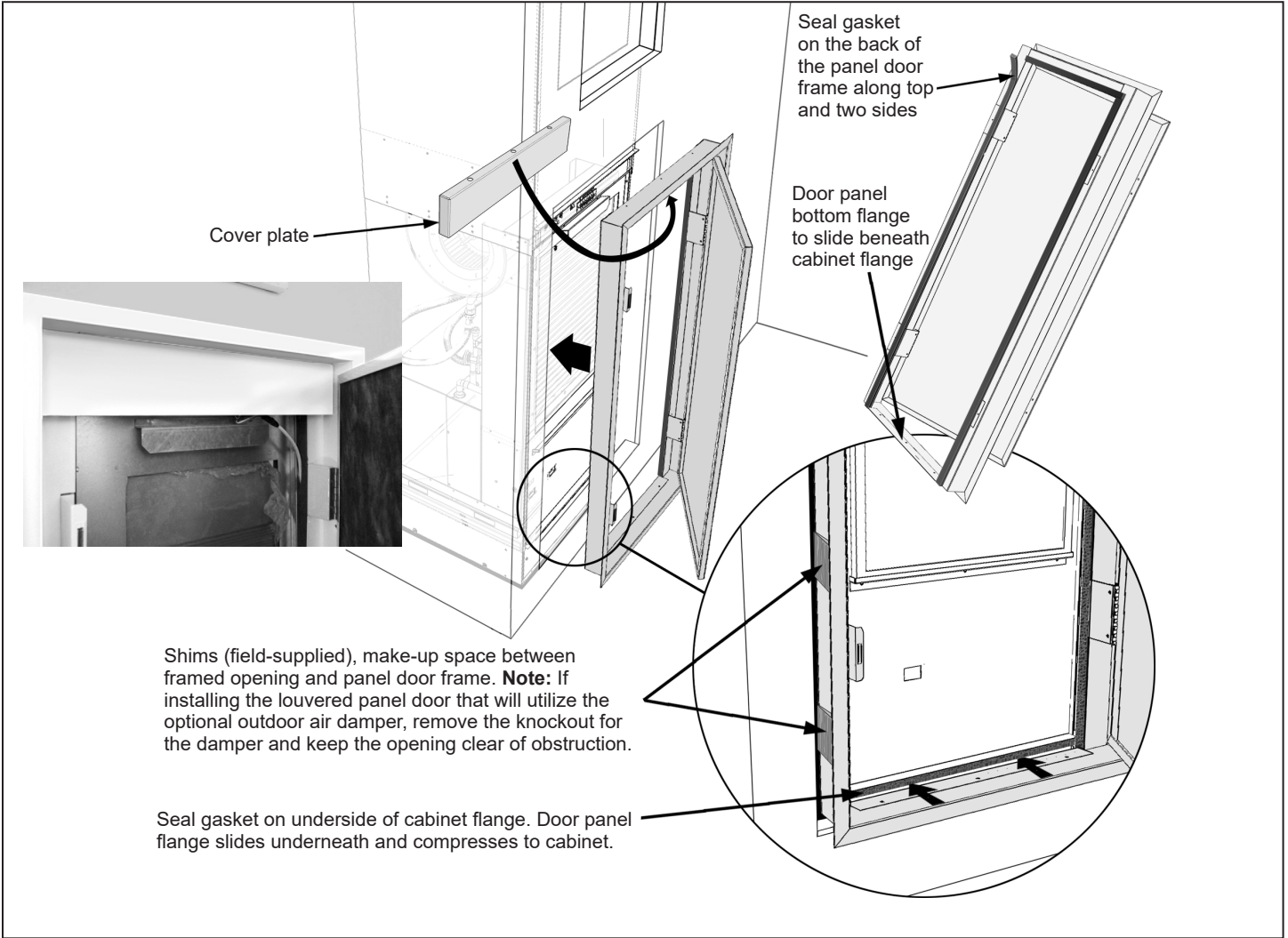

Installing the Optional Motorized Outdoor Air Damper with Louver Panel Door Only

1. Install the return air panel door assembly.
2. Fasten the damper assembly to the door frame with the provided screws. On left hand hinged doors the damper assembly will mount on the hinge side with the motor located at the bottom, and with right hand hinged doors the damper assembly will mount on the right side with the motor in the top position.
3. Wire the damper assembly motor using the correct schematic based on the unit motor type and voltage, (Figure 55 through Figure 60).

NOTICE

It is the responsibility of the installing contractor to install the ductwork that connects the outdoor air opening in the panel door frame to the source of the outdoor intake opening in the building. All ductwork should conform to industry standards of good practice as described in the ASHRAE Systems Guide. Also refer to good installation practices as outlined in ED 18529.

Figure 43: Fasten the Outside Air Damper Assembly to the Louver Panel Door Frame

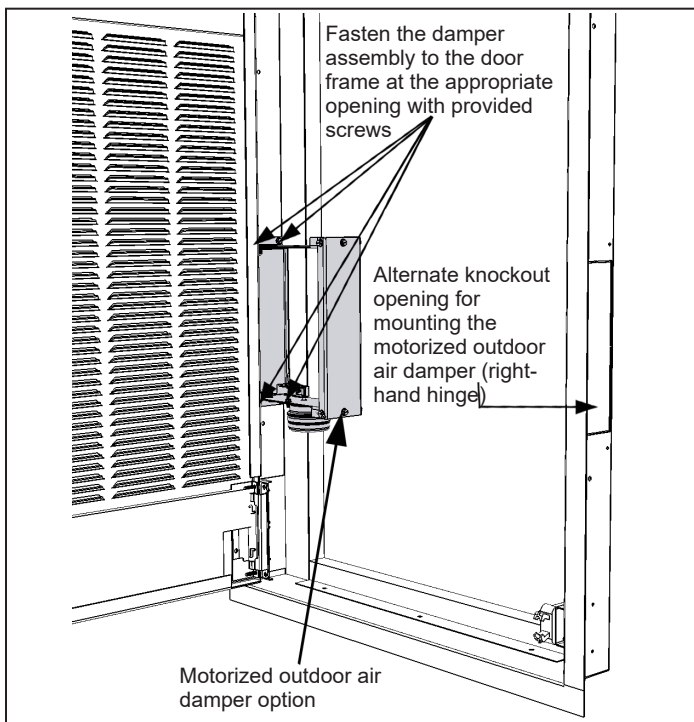

Installing The 3.25" Deep (2-Piece) Discharge Air Diffuser

NOTICE

Before installing drywall, install the diffuser extension frame portion of the two-piece 3.25" deep discharge air diffuser assembly to the unit. The louvered discharge air diffuser portion will slide in and be secured to the extension frame only after the unit has been framed-in and the discharge opening is cut out of the drywall.

NOTICE

To lessen noise transmission and air leakage, avoid metal-to-metal contact. Installation of a foam seal around the unit's discharge air opening is recommended.

1. Adhere field-provided 1/2" foam seal to the face of the cabinet around the perimeter of the discharge air opening (Figure 44).
2. Attach the extension frame portion of the two-piece discharge air diffuser assembly to the foam seal around the perimeter of the cabinet discharge opening.

NOTICE

Be sure the extension frame is level and plumb.

3. After the unit has been framed-in and the discharge opening is cut out of the drywall, slide in the louvered air diffuser through the finished drywall opening and connect to the extension frame. Secure with two (2) screws provided.

NOTICE

To avoid bending the adjustable discharge louvers, do not press on them.

NOTICE

When installed correctly, the diffuser frame should connect to the extension frame and seal to the cabinet discharge air opening so no discharge air is lost between the unit and the wall cavity.

Figure 44: Installing the 3.25" Deep (2-Piece) Discharge Air Diffuser

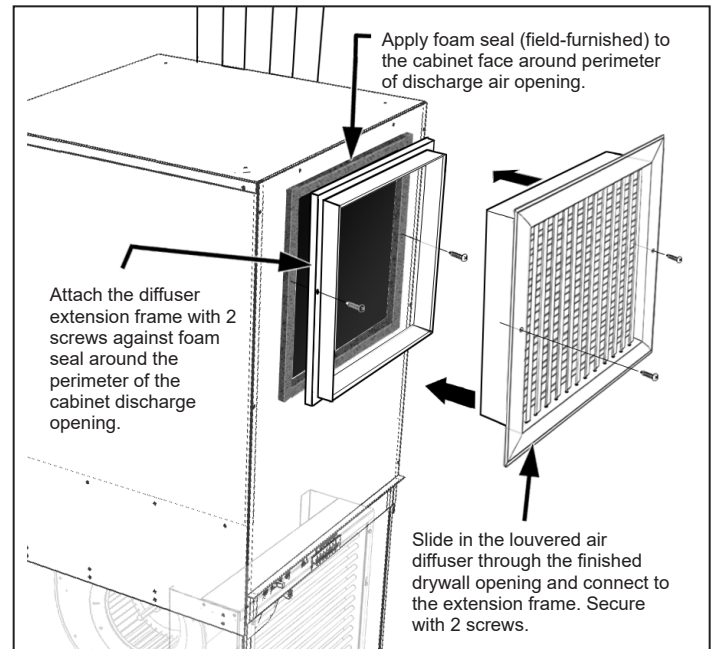

Installing the 1.75" Deep Discharge Air Diffuser

NOTICE

To lessen noise transmission and air leakage, avoid metal-to-metal contact. Installation of a foam seal around the unit's discharge air opening is recommended.

1. Adhere field-provided 1/2" foam seal to the face of the cabinet around the perimeter of the discharge air opening.
2. Insert the diffuser into the wall opening, and align the frame with the foam seal.

NOTICE

To avoid bending the adjustable discharge louvers, do not press on them.

3. Push the diffuser frame in until it compresses against the foam seal and the room side frame is flush against the drywall. Be sure the diffuser frame is level and plumb. Secure it with the two (2) screws provided.

NOTICE

When installed correctly, the diffuser frame should seal to the cabinet discharge air opening so no discharge air is lost between the unit and the wall cavity.

Figure 45: Installing the 1.75" Deep Discharge Air Diffuser

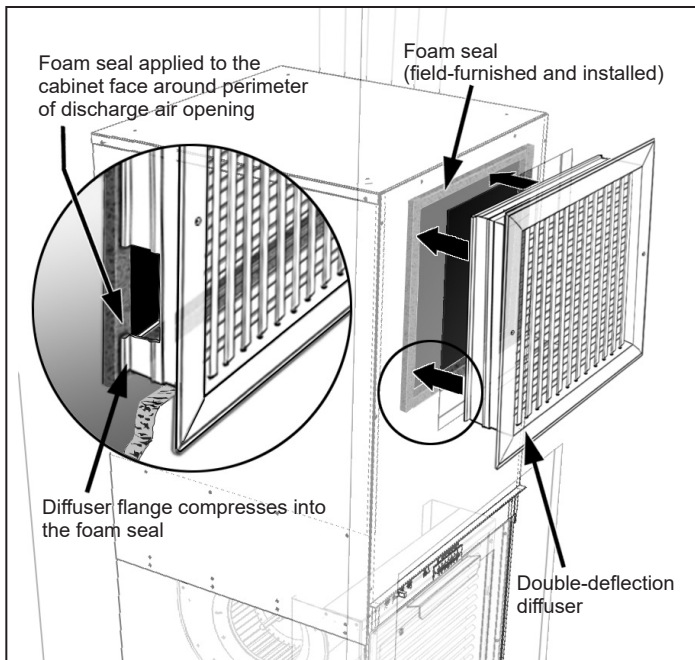

Twin Units Installation

Twin opposite hand units share a common riser system; i.e., supply, return, and drain riser. This is commonly called a "master/secondary" arrangement. The master unit is shipped with the risers attached. These special risers have stub-outs for both the master unit and the secondary unit which must be field connected and the following procedures must be followed for all twin unit installations.

1. Secondary units ship without risers and share common risers with the master unit. Knockout holes on the

cabinet are provided for the 6" stub outs to make piping connections to the coil supply and return and the condensate drain.

2. Master units are offered in two-pipe systems with either right-hand or left-hand connections. Secondary units are offered to accommodate internal connections to any of these riser systems or locations.
3. The riser location (right or left) is determined by facing the return air grille panel. The risers are located on either the right or left of the unit. This defines the riser location.
4. The riser block-off plates are located in the base of the secondary unit. Block-offs must be installed on the secondary unit before putting it into position.

Figure 46: Twin Unit Arrangement (Side by Side)

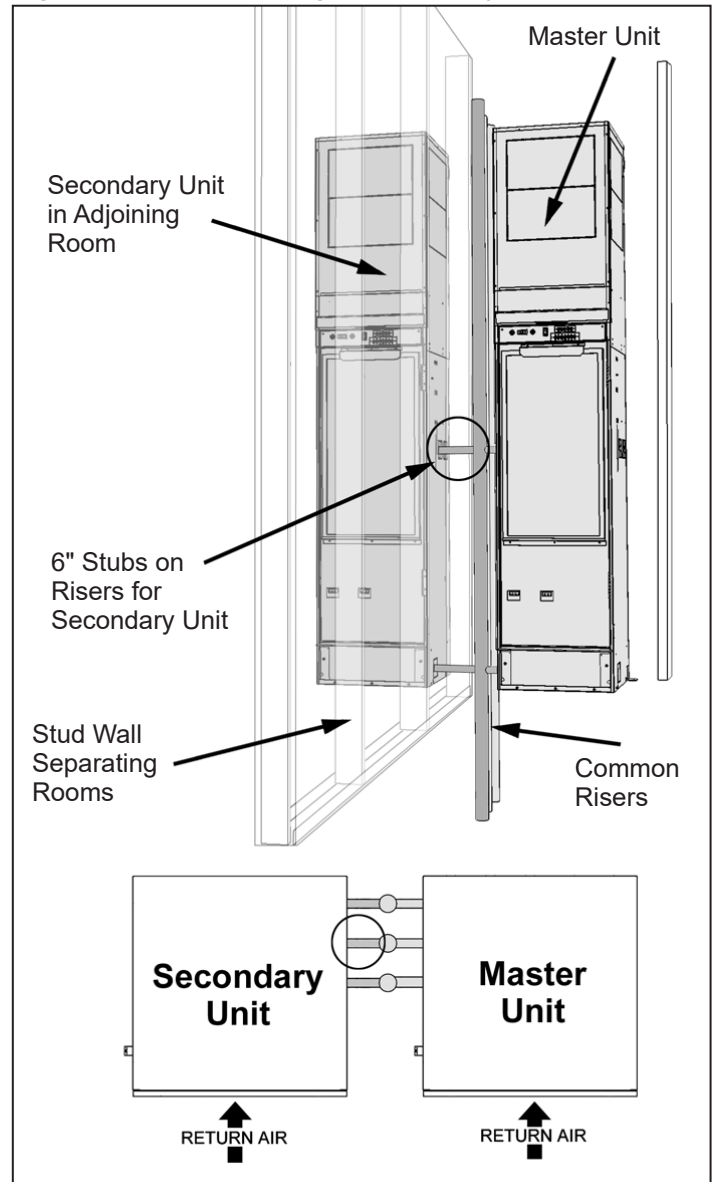

Field Installed Accessories

Wireless Temperature Control

The wireless thermostat option is designed to provide precision temperature control without the installation labor and expense of wiring.

- Powered by AA batteries
- Mounts in any suitable location that will provide good temperature control.
- Large LCD display provides the user with current room temperature, set point temperature, time, program interval, and other system status information.

For detailed installation and operation information, refer to the manual provided with the thermostat.

Figure 47: Wireless Thermostat Option



The second part of the wireless system is called a Remote Control Node (RCN). An RCN interfaces with specific desired HVAC equipment, and communicates with its thermostat wirelessly. At the time of installation, the wireless thermostat is linked to the RCN. The thermostat and RCN that have been linked will not interfere with, or be affected by, any other thermostat or RCN in adjacent rooms, apartments, or neighboring homes.

Figure 48: Remote Control Node (RCN)



Return Air Temperature Sensor Location for Units with Optional Wireless Thermostat

For units with the optional wireless thermostat, a Return Air Temperature (RAT) sensor is required. The RAT must be wired back to the wireless thermostat Remote Control Node (RCN). In the event that the connection between the RCN and the wireless thermostat is lost, the RCN will control the unit based on the hardwired RAT sensor. For reference, see [Figure 49](#) for the location of the RAT sensor when the RCN is factory installed.

Figure 49: Return Air Temperature Sensor Location



Motorized Isolation Valve Kit

The motorized valve kit is available as a factory-installed or a field-installed option. Wired as shown in Figure 50, the motorized valve will open on a call for compressor operation. The motorized isolation valve actuator (ISO) has both a 24V power connection and a 24V end switch connection.

1. Install the supplied wire harness into plug H6 on the main control board.
2. Run wires between the ISO actuator and the supplied wire harness ends.

3. Connect N.O. & N.C. actuators as shown on the schematic.
4. The end switch should be wired in series with the 24V compressor signal wire. Connect the end switch wires as shown in the schematic. The end switch will close when the valve is fully open.

NOTICE

For detailed installation instructions for the motorized valve, refer to IM 1151.

Figure 50: Motorized Valve Wiring

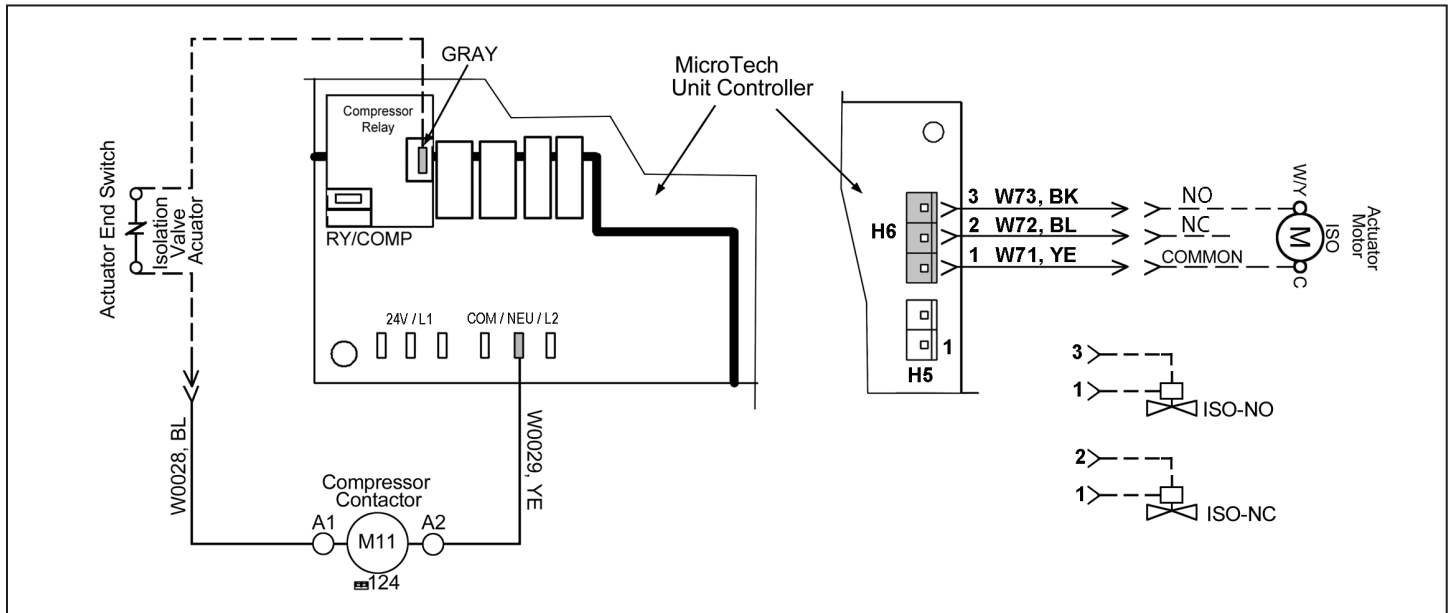

NOTE: Image is representative and board may differ slightly.

Figure 51: MT2300 Wiring to an Existing Motorized Valve from a Previously Installed Unit with MicroTech III Controller

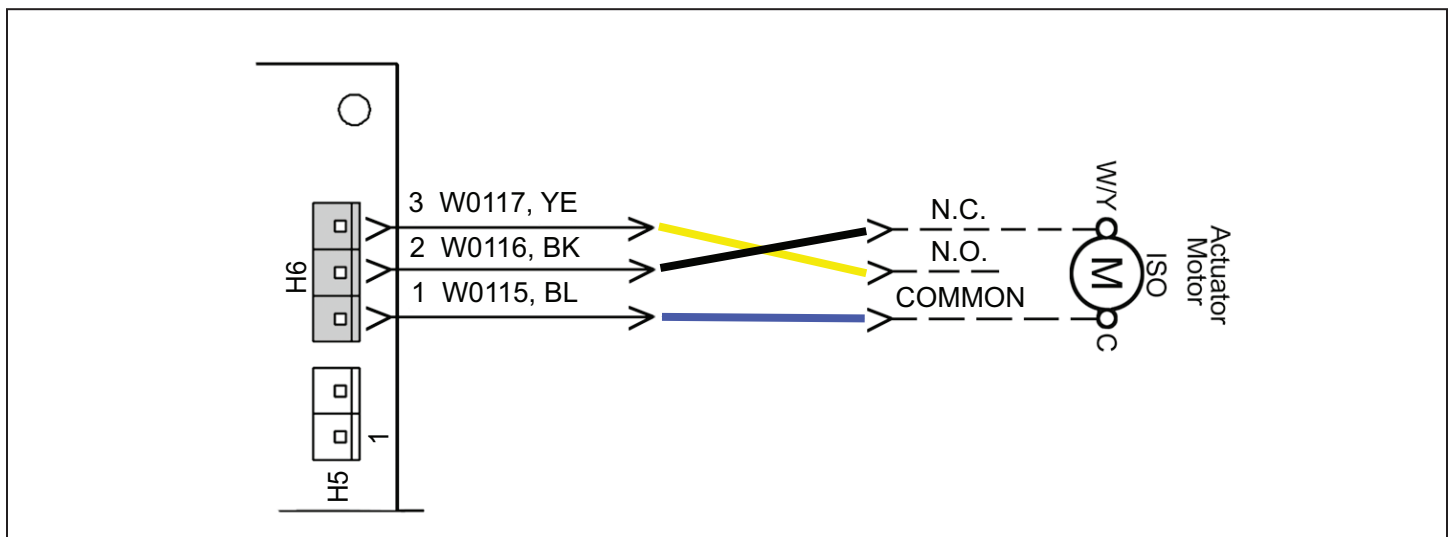

NOTE: If reusing a motorized valve on an existing Daikin Applied R-410A unit, the wiring harness for connections 1, 2, and 3 for the R32 product are different. Therefore, the wiring connections (Common, N.O., and N.C.) to the motorized valve must be rewired.

Typical Wiring Diagrams

MicroTech Unit Controller, EC Motor — Thermostat Control 208-230/60/1 Unit Size 009

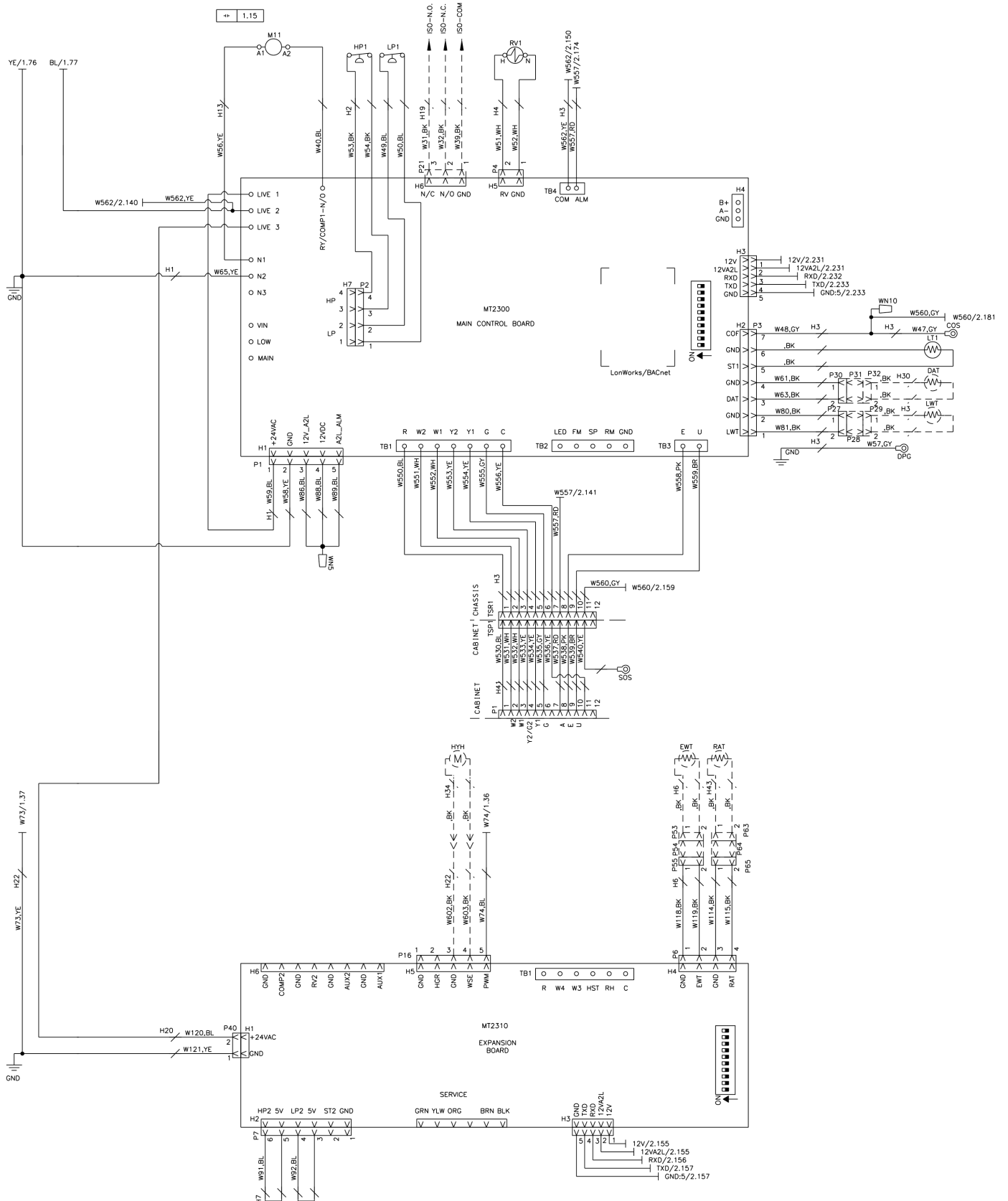

MicroTech Unit Controller, EC Motor — Sensor Control with Communication Module 208-230/60/1 Unit Size 009

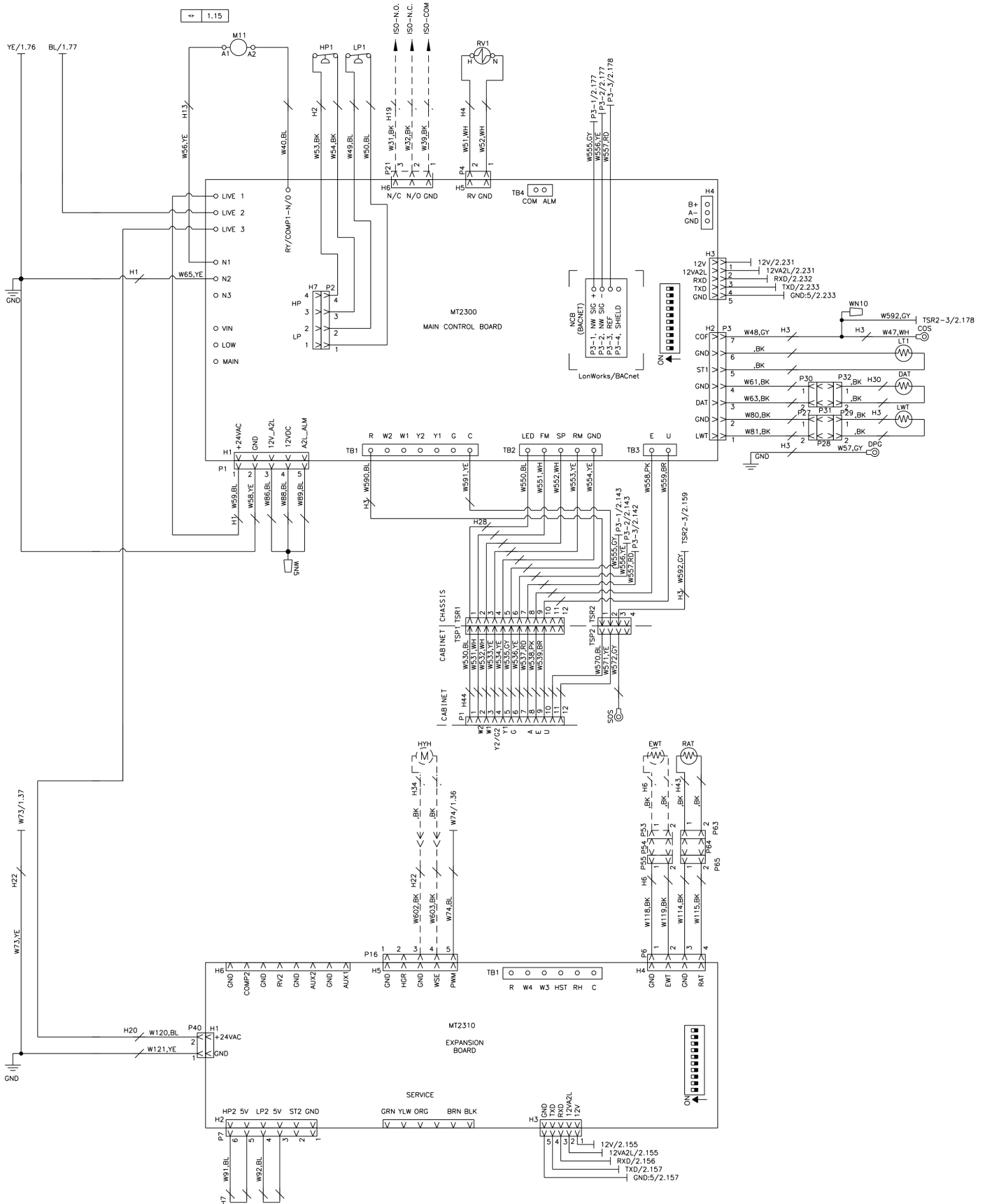

MicroTech Unit Controller, EC Motor — Thermostat Control 265/60/1 Unit Sizes 009-012

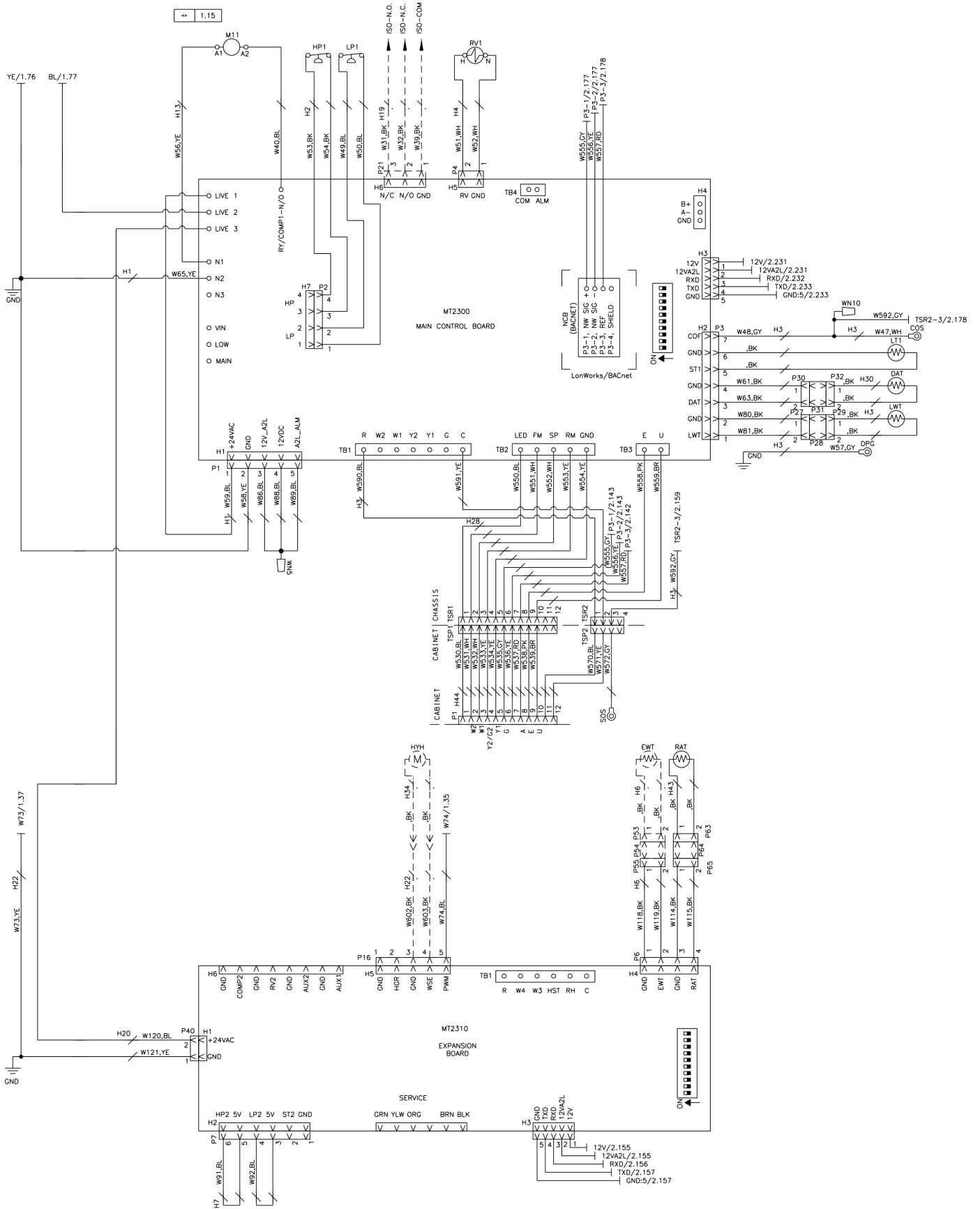

MicroTech Unit Controller, EC Motor — Sensor Control with Communication Module 265/60/1 Unit Sizes 009-012

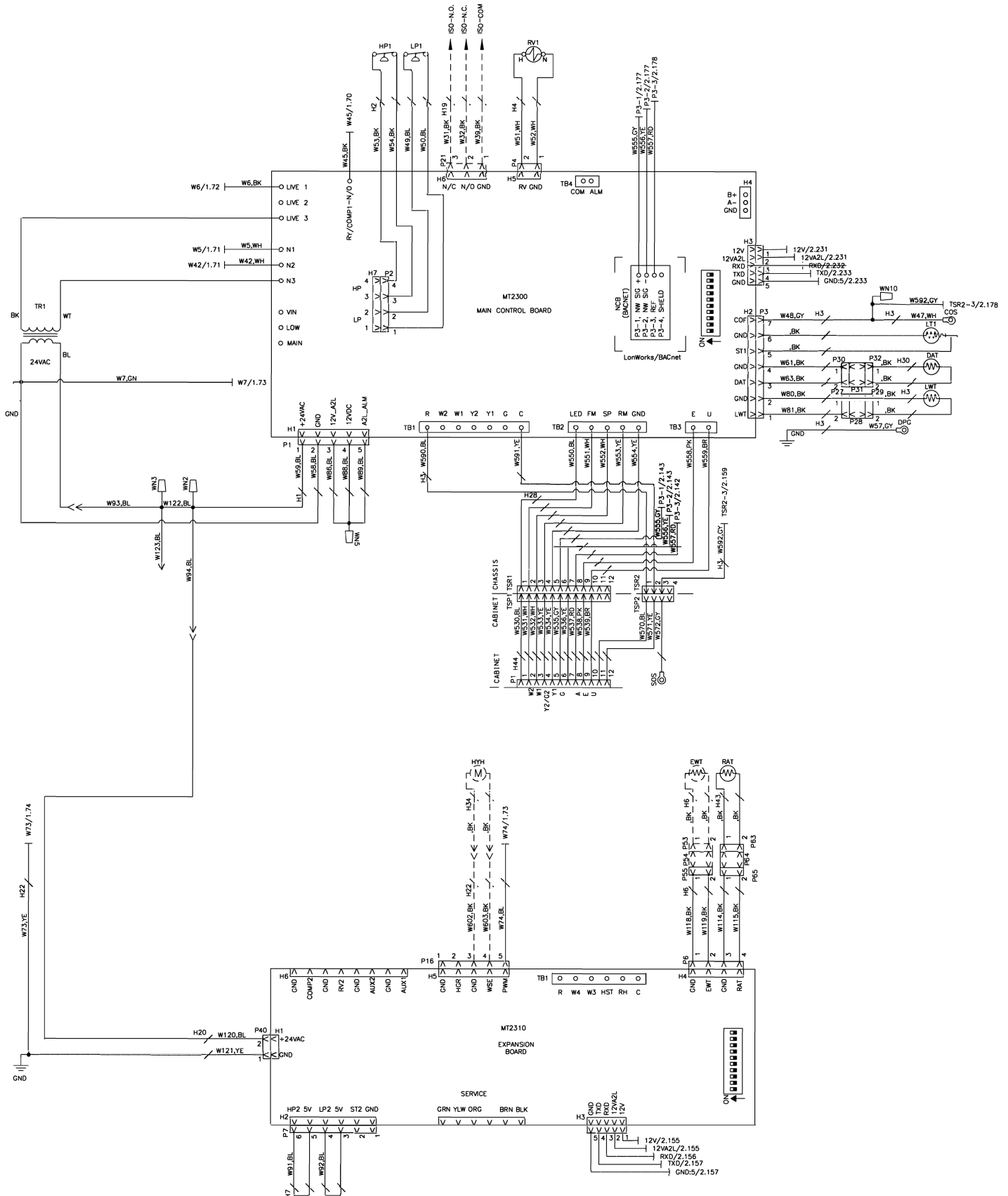

MicroTech Unit Controller, PSC Motor — Thermostat Control 265/60/1 Unit Size 024

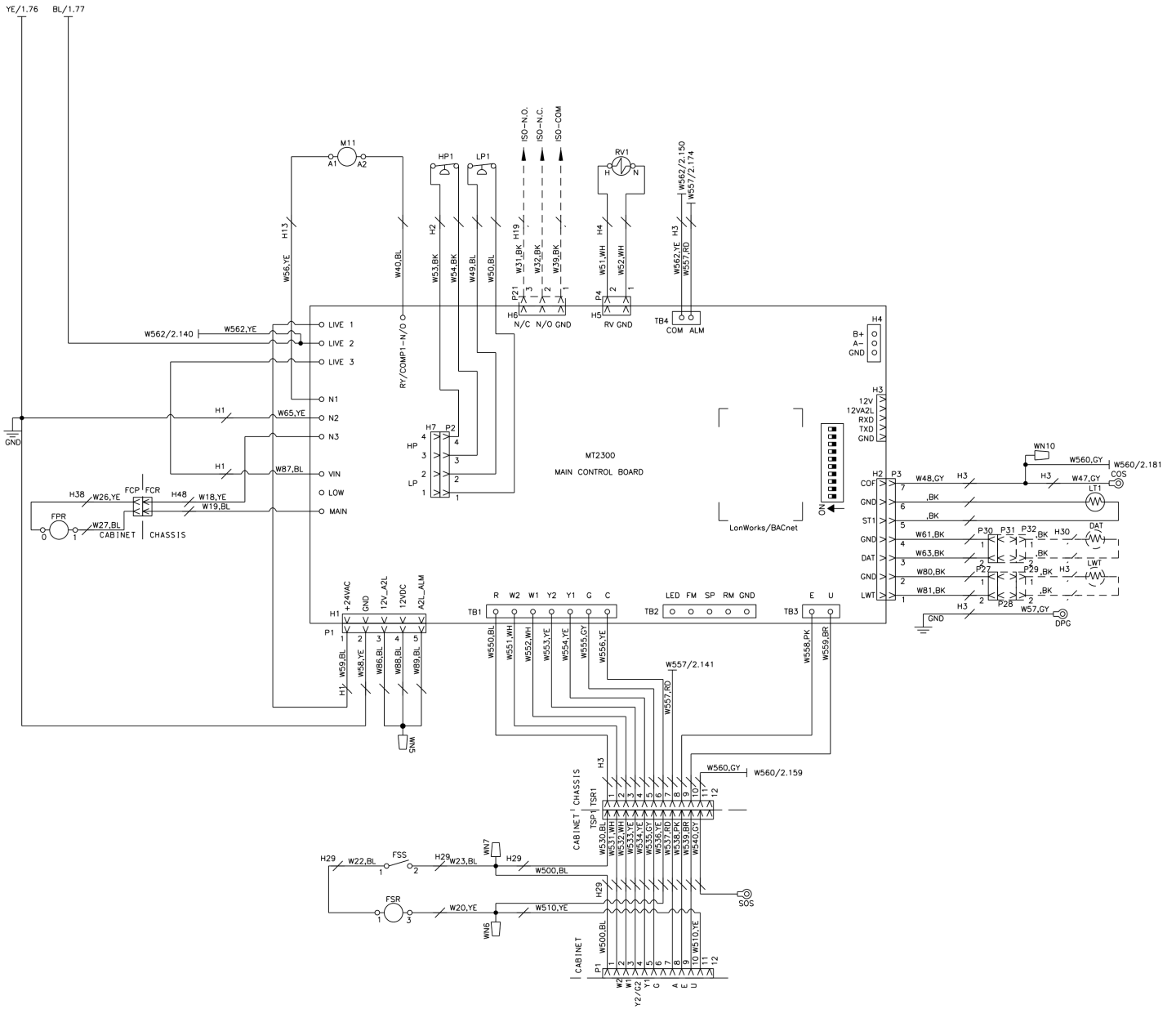

MicroTech Unit Controller, PSC Motor — Thermostat Control 265/60/1 Unit Sizes 030-036

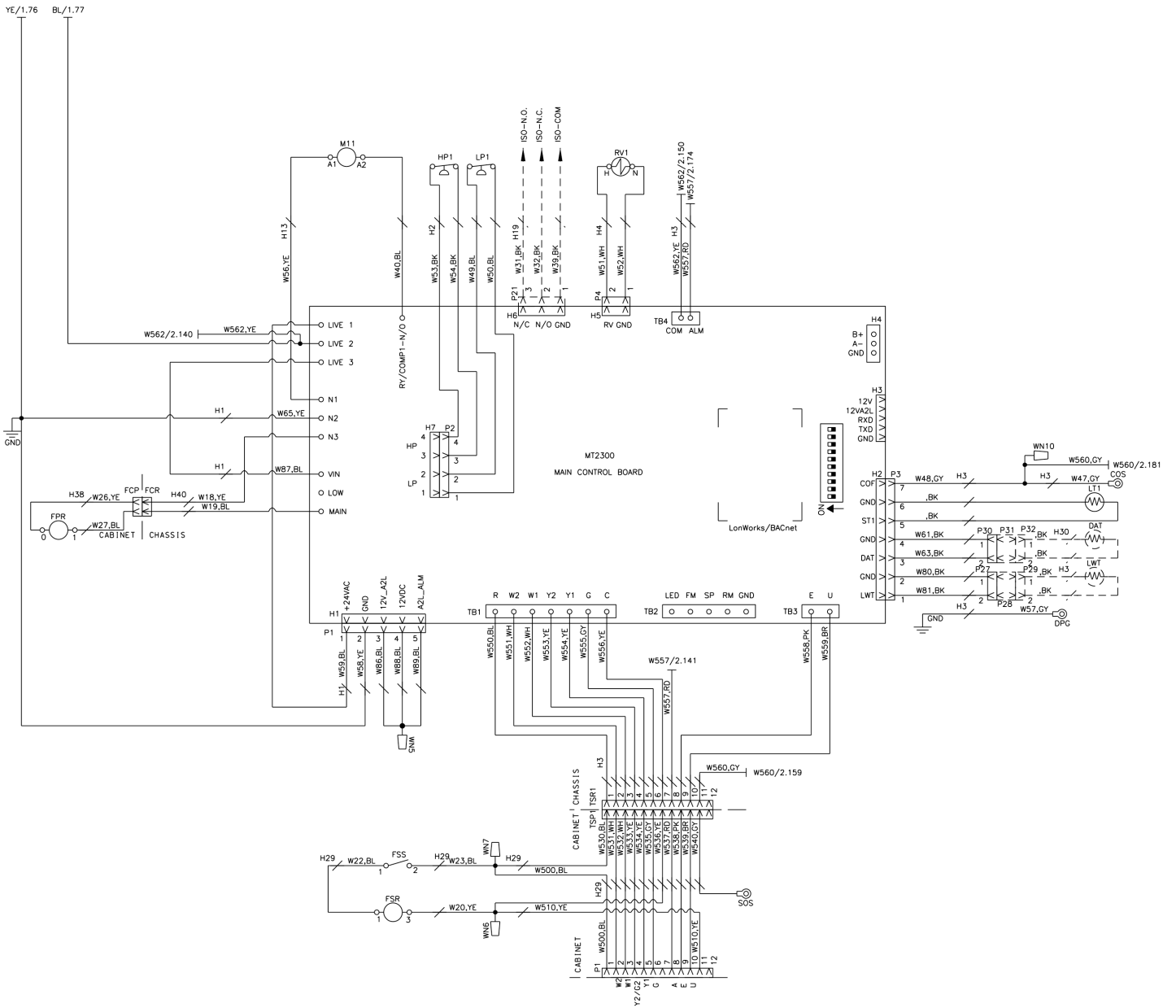

MicroTech Unit Controller, PSC Motor — Thermostat Control 208-230/60/1 Unit Size 024

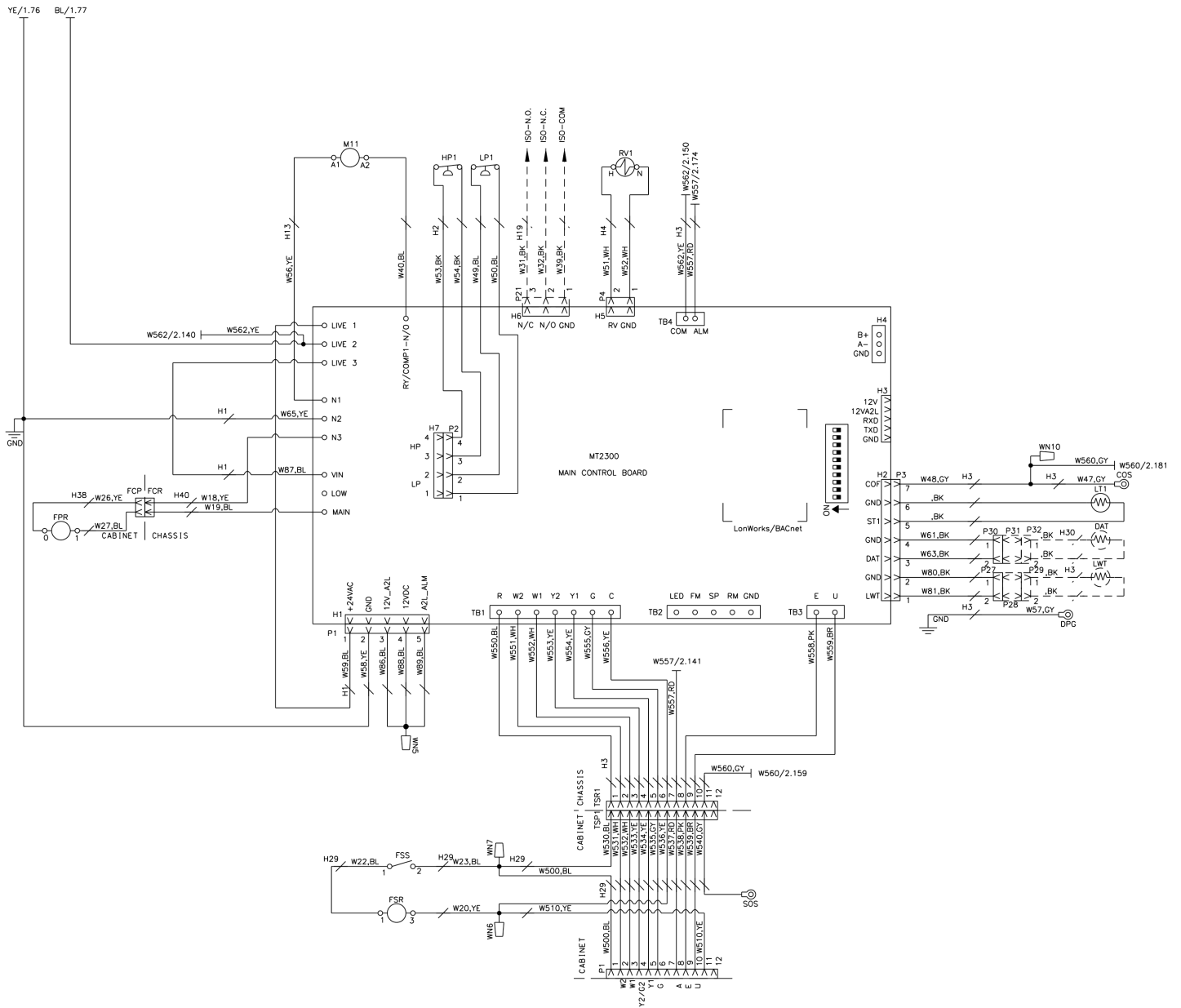

MicroTech Unit Controller, PSC Motor — Thermostat Control 208-230/60/1 Unit Sizes 030-036

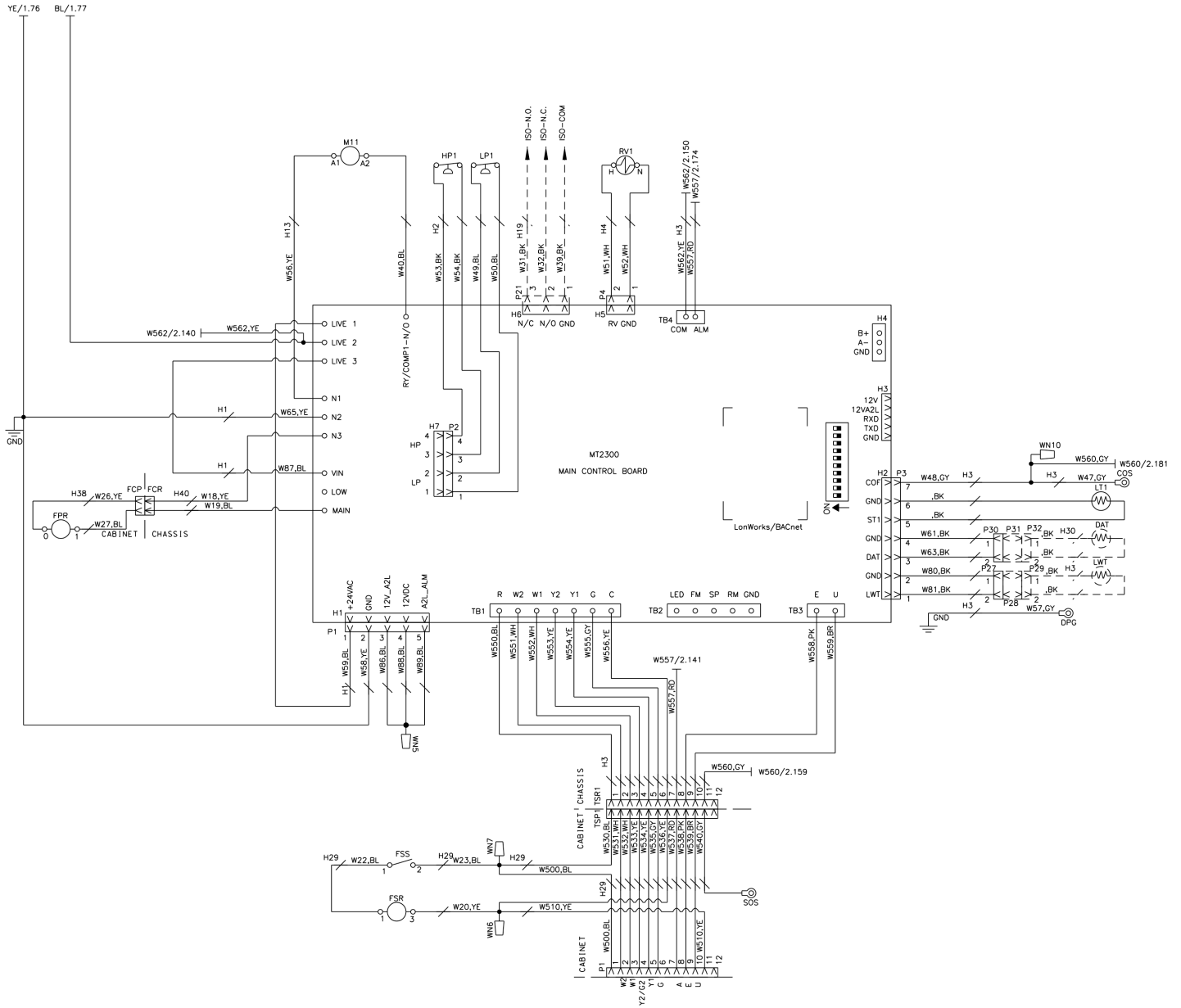

Wiring Schematics Legend

LEGEND	
CO1	Fan Motor 1 Capacitor
C11	Compressor 1 Capacitor
CP1	Compressor 1
COE	Condensate Overflow Protection Sensor - WSE
COS	Condensate Overflow Protection Sensor
DAT	Discharge Air Temperature Sensor
DCS	Disconnect Switch
EWT	Entering Water Temperature Sensor
FM1	Fan Motor 1
GND	Ground
HG1	Hot Gas Reheat Valve Actuator
HP1	High Pressure Switch
HYH	Hot Water Heat Valve Actuator
LAT	Leaving Air Temperature Sensor
LP1	Low Pressure Switch
LT1	Compressor Suction Line Temperature Sensor
LWT	Leaving Water Temperature Sensor
M01	Fan Motor Contactor
M11	Compressor 1 Contactor
NCB	Network Control Board
OLP	Overload Protector - Compressor Motor
RAT	Return Air Temperature Sensor
RV1	Reversing Valve
TR1	Transformer - Control
TR2	Transformer - Fan Motor
W0001	Wire
WH001	Wire Harness
WN1	Wire Nut
WP001	Wire Plug
WSE	Waterside Economizer Actuator

NOTE: Devices in legend may or may not be on unit.

Operation

Start-Up

CAUTION

Units must be checked for water leaks upon initial water system start-up. Water leaks may be a result of mishandling or damage during shipping. Failure by the installing contractor to check for leaks upon start-up of the water system could result in property damage

Check, Test & Start Procedure

NOTICE

Complete the "Water Source Heat Pump Equipment Check, Test and Start Form" on page 38.

MT2300 Board LED Indicator

When the unit controller is communicating a certain fault or mode, the LED indicator will flash a designated pattern or sequence. See Figure 52 for the location of the MT2300 board LED indicator. Table 17 gives a description of the LED activity. Refer to OM 1364 for additional information.

Table 17: MT2300 Board LED Indicator Sequence

LED Activity	Type	Color	Description
1 Flash	Mode	Green	No Call for Heating/Cooling/Dehumidification
2 Flash	Mode	Green	Call for Cooling
3 Flash	Mode	Green	Call for Heating
4 Flash	Mode	Green	Call for Fan Only

Figure 52: LED Indicator on MT2300 Board

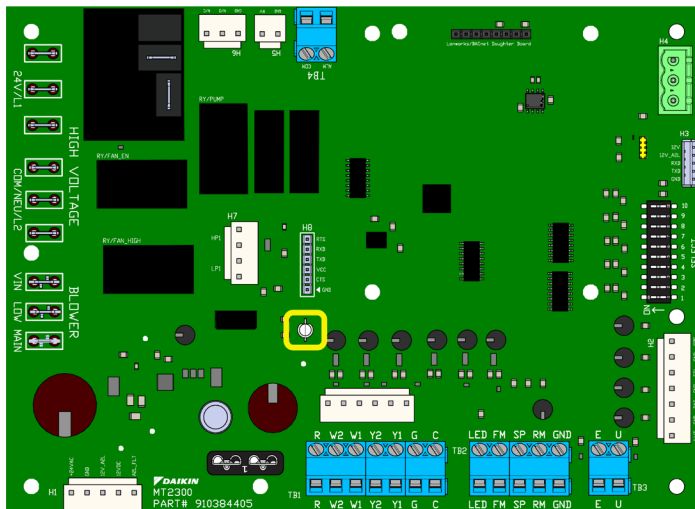

Check as completed:

NOTICE

To prevent compressor cycling and all compressors from starting up together after loss of power, the required minimum on/off time default is 300 seconds plus the random restart of 0 to 60 seconds.

- Open all valves to full open position and turn on power to the unit.
- Set thermostat for "Fan Only" operation by selecting "Off" at the system switch and "On" at the fan switch. If "Auto" fan operation is selected, the fan will cycle with the compressor. Check for proper air delivery.
- Check the unit controller LED indicator for "Fan Only" mode operation.
- Set thermostat to "Cool." If the thermostat is an automatic changeover type, simply set the cooling temperature to the coolest position. On manual changeover types additionally select "Cool" at the system switch.
- Check the unit controller LED indicator for "Cool" mode operation.
- After a few minutes of operation, check the discharge grilles for cool air delivery. To insure proper water flow, measure the temperature difference between entering and leaving water. The temperature differential should be 10°F to 14°F (5°C to 8°C) for units in cooling mode. It should be approximately 1½ times greater than the heating mode temperature difference. For example, if the cooling temperature difference is 15°F (8°C), the heating temperature difference should have been 10°F (5°C).
- Without automatic flow control valves, target a cooling temperature difference of 10°F to 14°F (5°C to 8°C). Adjust the combination shutoff/balancing valve in the return line to a water flow rate which will result in the 10°F to 14°F (5°C to 8°C) difference.
- Set thermostat to "Heat." If the thermostat is the automatic changeover type, set system switch to the "Auto" position and depress the heat setting to the warmest selection. With most control schemes, the fan will start immediately. After a few minutes of compressor operation, check for warm air delivery at discharge grille. If this is a "cold building" start-up, leave unit running until return air to the unit is at least 65°F (18°C).
- Check the unit controller LED indicator for "Heat" mode operation.
- Measure the temperature difference between entering and leaving air and entering and leaving water. With entering water of 60°F to 80°F (16°C to 27°C), leaving water should be 6°F to 12°F (3.3°C to 6.6°C) cooler, and the air temperature rise through the machine should not exceed 35°F (19°C). If the air temperature exceeds 35°F (19°C), then the water flow rate is inadequate.
- Check the elevation and cleanliness of the condensate line. If the air is too dry for sufficient dehumidification, slowly pour enough water into the condensate pan to ensure proper drainage.

- If the unit does not operate, check the following points:
 - Is supply voltage to the machine compatible?
 - Is thermostat type appropriate?
 - Is thermostat wiring correct?
- If the unit operates but stops after a brief period:
 - Is there proper airflow? Check for dirty filter, incorrect fan rotation (3-phase fan motors only), or incorrect ductwork.
 - Is there proper water flow rate within temperature limits? Check water balancing; back flush unit if dirt-clogged.
- Check for refrigerant piping rubbing against cabinet or other piping causing vibration. Check fan wheels, set screws, shaft, etc.

Controls

Table 18: MicroTech 2300 Unit Controller Connector and Terminal Descriptions

Connector	I/O	Type	Signal	Description
H1-1	24 VAC	Power	VAC	Control Power Voltage
H1-2	GND	Power	Ground	Control Power Common
H1-3	12V A2L	Input	VDC	A2L Sense Voltage
H1-4	12 VDC	Output	VDC	A2L Mitigation Voltage
H1-5	A2L FLT	Input	Digital	A2L Fault Alarm
H2-1	LWT	Input	Analog	Leaving Water Temperature
H2-2	GND	REF	Common	
H2-3	DAT	Input	Analog	Discharge Air Temperature
H2-4	GND	REF	Common	
H2-5	ST1	Input	Analog	Comp1 Suction Temperature
H2-6	GND	REF	Common	
H2-7	COF	Input	Analog	Condensate Overflow
H3-1	12 VDC	Output	VDC	Base/Expansion Board Interface
H3-2	12V A2L	Output	VDC	
H3-3	RXD	COM	UART	
H3-4	TXD	COM	UART	
H3-5	GND	COM	UART	
H4-1	B(+)	COM	N/A	Future Use
H4-2	A(-)	COM	N/A	
H4-3	GND	COM	N/A	
H5-1	GND	REF	Common	Comp1 Reversing Valve
H5-2	RV	Output	24 VAC	
H6-1	N/C	Output	24 VAC	Pump Request - Normally Closed Terminal for Normally Open Valves
H6-2	N/O	Output	24 VAC	Pump Request - Normally Open Terminal for Normally Closed Valves
H6-3	GND	REF	Common	Pump Request
H7-1,2	HP1	Input	Digital	Comp1 High Pressure
H7-3,4	LP1	Input	Digital	Comp1 Low Pressure
TB1-1	R	Output	24 VAC	Thermostat 24 VAC Power
TB1-2	W2	Input	24 VAC	Thermostat Heat Stage 2
TB1-3	W1	Input	24 VAC	Thermostat Heat Stage 1
TB1-4	Y2	Input	24 VAC	Thermostat Cool Stage 2
TB1-5	Y1	Input	24 VAC	Thermostat Cool Stage 1
TB1-6	G	Input	24 VAC	Thermostat Fan
TB1-7	C	REF	Common	Thermostat Common
TB2-1	LED	Output	5 VDC	Room Sensor LED
TB2-2	FM	Input	Analog	Room Sensor Fan/Mode

Connector	I/O	Type	Signal	Description
TB2-3	SP	Input	Analog	Room Sensor Setpoint Adjust
TB2-4	RM	Input	Analog	Room Sensor Air Temp / Tenant Override
TB2-5	GND	REF	Common	Room Sensor
TB3-1	E	Input	Digital	Emergency Shutdown
TB3-2	U	Input	Digital	Unoccupied Sensor
TB4-1,2	ALM	Output	Digital	Alarm Output - Contact Closure
BLOWER	VIN	Input	VAC	Blower Motor Voltage
BLOWER	LOW	Output	VIN	Blower Motor Low Speed
BLOWER	MAIN	Output	VIN	Blower Motor High Speed or ECM
LIVE (Relay)	Comp1	Output	L1/24V	Compressor Stage 1
LIVE x 3	24V/L1	Input	VAC	COMP1 Line1 Control Voltage
LIVE x 3	COM/NEU/L2	Input	VAC	COMP1 Line2 Control Voltage
Daughter Board	BACnet	COM	SPI	BACnet MS/TP Only

Table 19: MT2310 I/O Board Connectors and Terminals

Connector	I/O	Type	Signal	Description
H1-1	GND	Power	Ground	Control Power Common
H1-2	24 VAC	Power	VAC	Control Power Voltage
H2-1	GND	REF	Common	Comp2 Suction Temperature
H2-2	ST2	Input	Analog	
H2-3,4	LP2	Input	Digital	Comp2 Low Pressure
H2-5,6	HP2	Input	Digital	Comp2 High Pressure
H3-1	12 VDC	Input	VDC	Base/Expansion Interface
H3-2	12V A2L	Input	VDC	
H3-3	TXD	COM	UART	
H3-4	RXD	COM	UART	
H3-5	GND	REF	Common	
H4-1	GND	REF	Common	Entering Water Temperature
H4-2	EWT	Input	Analog	
H4-3	GND	REF	Common	Return Air Temperature
H4-4	RAT	Input	Analog	
H5-1	GND	REF	Common	Hot Gas Reheat Valve
H5-2	HGR	Output	24 VAC	
H5-3	GND	REF	Common	Waterside Economizer Valve
H5-4	WSE	Output	24 VAC	
H5-5	PWM	Output	PWM	Variable Speed Blower Motor
H6-1	GND	REF	Common	Compressor Stage 2
H6-2	COMP2	Output	24 VAC	
H6-3	GND	REF	Common	Comp2 Reversing Valve
H6-4	RV2	Output	24 VAC	
H6-5	GND	REF	Common	Auxiliary Heat 2
H6-6	AUX2	Output	24 VAC	
H6-7	GND	REF	Common	Auxiliary Heat 1 / Hydronic Heat
H6-8	AUX1	Output	24 VAC	
TB1-1	C	REF	Common	Input Common
TB1-2	RH	Input	Analog	Space Relative Humidity
TB1-3	HST	Input	24VAC	Humidistat
TB1-4	W3	Input	24VAC	Thermostat - Stage 3 Heat
TB1-5	W4	Input	24VAC	Thermostat - Stage 4 Heat or Stage 3 Cool
TB1-6	R	Output	24 VAC	Thermostat - 24 VAC Power

Figure 53: MicroTech2300 Unit Controller and MicroTech 2310 I/O Expansion Board Terminal Location

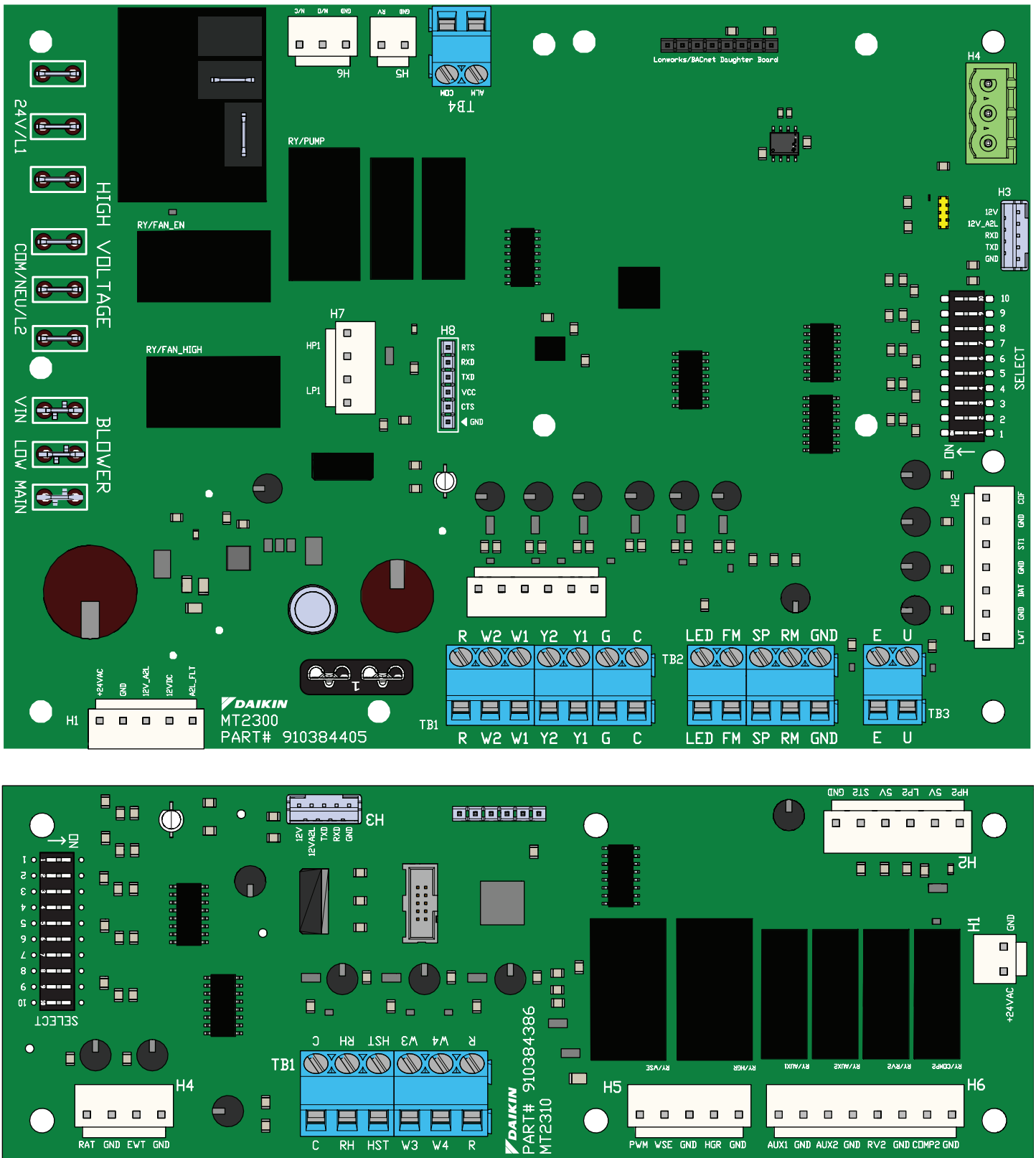

Configuration DIP Switches

⚠ WARNING

Proper antifreeze/water solution is required to minimize the potential of fluid freeze-up. DIP switch 3 (SW3) is factory set for water freeze protection with the switch in the OFF position. Operation at fluid temperatures below 32°F (0°C) with anti-freeze protection requires SW3 to be field configured for the switch on. If unit is employing a fresh water system (no anti-freeze protection), it is extremely important that SW3 setting remains in the OFF position (factory default setting) in order to shut down the unit at the appropriate water temperature to protect your heat pump from freezing. Failure to do so can result in unit damage or property damage and will void unit warranty.

Figure 54: Location of Configuration DIP Switches on the MT2300 Unit Controller

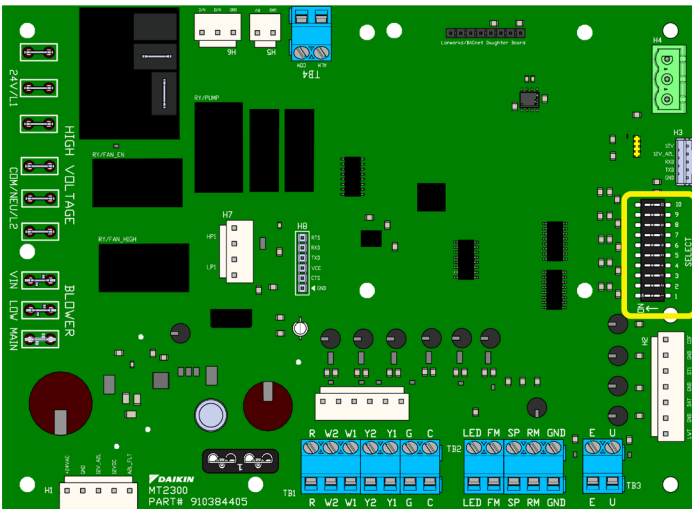

⚠ CAUTION

The MT2300 unit controller incorporates static sensitive devices. A static charge from touching the device can damage the electronic components. To help prevent damage during service, use static discharge wrist straps. Static discharge wrist straps are grounded to the heat pump chassis through a 1M ohm resistor.

Table 20: MT2300 Main Board DIP Switch Settings

Switch	Description	Position	Model/Options
SW1	Normal/Test Mode	SW1 = OFF (0)	Normal Operation
		SW1 = ON (1)	Service/Test Mode
SW2	Fan Operation	SW2 = OFF (0)	Continuous Fan Operation (On)
		SW2 = ON (1)	Cycling Fan Operation (Auto)
SW3	Loop Fluid	SW3 = OFF (0)	Water Loop Fluid
		SW3 = ON (1)	Glycol Loop Fluid
SW4	Freeze Fault Detect (FFD)	SW4 = OFF (0)	Disabled FFD
		SW4 = ON (1)	Enabled FFD with LWT sensor installed
SW5	Room Sensor Setpoint Adjust Range	SW5 = OFF (0)	Short Range -5 to +5 F (-2.78 to +2.78 C)
		SW5 = ON (1)	Long Range 55 to 95 F (12.78 to 35 C)

Switch	Description	Position	Model/Options
SW6	Thermostat/Room Sensor Control	SW6 = OFF (0)	Thermostat Control
		SW6 = ON (1)	Room Sensor Control
SW7/SW8	Single Compressor Heating Source	SW7 = OFF (0)	Allow Compressor in Heating Mode
		SW7 = ON (1)	Disable Compressor in Heating Mode
	Single Compressor I/O Expansion Module	SW8 = OFF (0)	I/O Expansion Module Not Required
		SW8 = ON (1)	I/O Expansion Module is Required
	Two Compressor Availability	SW7 = OFF (0) SW8 = OFF (0)	Both Compressors Available (Automatic Compressor Fail Replace)
		SW7 = ON (1) SW8 = OFF (0)	Lead Compressor Available (Lag Compressor is Off-Line)
	SW7 = OFF (0) SW8 = ON (1)	No Compressors Available	
SW9	WSHP Base Board Application Select	SW9 = OFF (0)	Single Compressor WSHP Application
		SW9 = ON (1)	Two Compressor Application
SW10	Discrete/Variable Speed Fan Select	SW10 = OFF (0)	Fan Single (Fan Main Output) or Variable (PWM) Speed
		SW10 = ON (1)	Dual Speed Fan (Low & High Discrete Outputs)

NOTE: The functionality of SW7 and SW8 depends on the setting of SW9. If SW9 is OFF, SW7 and SW8 will be for Heating Source and I/O Expansion Module functionality. If SW9 is ON, SW7 and SW8 will be for Compressor Availability functionality.

Figure 55: MT2310 I/O Expansion DIP Switches

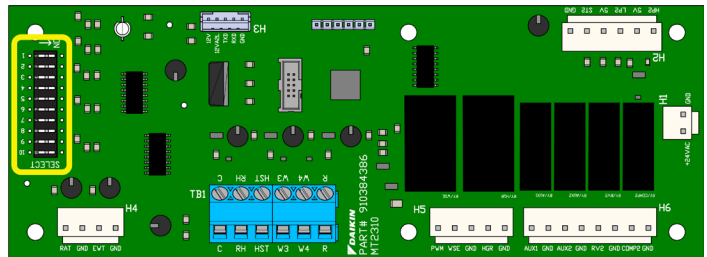

Table 21: MT2310 I/O Expansion Module DIP Switch Settings

Switch	Description	Position	Model/Options
SW1-4	Variable Fan Speed Row Selection	0000 to 1111 Binary	Variable Speed Fan Row Selection (1 to 16), used when "nciVsNetCnfgEn" is set to "Disable" the network override.
SW5/SW6	Secondary Heating Options	SW5 = OFF (0) SW6 = OFF (0)	None
		SW5 = ON (1) SW6 = OFF (0)	Supplemental Electric Heat
		SW5 = OFF (0) SW6 = ON (1)	Boilerless Electric Heat
		SW5 = ON (1) SW6 = ON (1)	Hydronic Heating

Switch	Description	Position	Model/Options
SW7	Hot Gas Reheat (HGR)	SW7 = OFF (0)	HGRH Disabled
		SW7 = ON (1)	HGRH Enabled
SW8	Waterside Economizer (WSE)	SW8 = OFF (0)	Waterside Economizer Disabled
		SW8 = ON (1)	Waterside Economizer Enabled
SW9	WSHP I/O Expansion Application Select	SW9 = OFF (0)	Single Compressor Application
		SW9 = ON (1)	Two Compressor Application
SW10	Single Compressor: Speed	SW10 = OFF (0)	Single Speed Compressor
		SW10 = ON (1)	Dual Speed Compressor
	Two Compressor: Lead Compressor Select	SW10 = OFF (0)	Compressor #1 is Lead
		SW10 = ON (1)	Compressor #2 is Lead

NOTE: The functionality of SW10 depends on the setting of SW9. If SW9 is OFF, SW10 will be for Single Compressor Speed. If SW9 is ON, SW10 will be for Lead Compressor Select.

MicroTech SmartSource Unit Controller

The MicroTech SmartSource unit controller allows thermostat, Daikin Applied sensor and DDC standalone operation. The R (24VAC) terminal is used to operate thermostat inputs G, Y1, Y2, W1, W2, W3, W4 and TB1. The C (common) terminal is used to control inputs U and E. No external power sources may be used to operate the MicroTech controller. All units must be properly grounded per local code requirements.

NOTICE

For information on sequence of operation and troubleshooting refer to OM 1364.

Remote Reset of Automatic Lockouts

The Remote Reset feature provides the means to remotely reset automatic lockouts. There are three (3) ways to accomplish a unit reset once the fault condition has been remedied:

- Using the thermostat, cycle from cool or heat to off and back to heat or cool two times within 30 seconds.
- Press the Room Sensor or Thermostat Timed Override/Reset Button for more than 10 seconds.
- Turn the unit power off and wait 10 seconds to turn back on.

When the cause of the fault condition has been remedied, and the unit is cycled from not requiring heating or cooling to needing heating or cooling twice within 30 seconds (accomplished by user manipulation of the Heat/Cool/ Auto/Off switch on the thermostat), an alarm reset equivalent to a tenant override button reset is generated. The intelligent reset counter and the 24 hour timer are cleared when this type of alarm reset is generated.

NOTICE

This feature only applies to thermostat controlled systems.

For room sensor controlled units, pressing the “Override” or “Reset” button for more than 10 seconds will apply a ground signal to the Room Temperature Sensor connection at TB2 pin 4, RS clearing the lockout alarm once the cause of the fault condition has been remedied.

A unit power cycle can also be used to clear an automatic lockout if the conditions causing the fault have been remedied.

Table 22: MT2300 Unit Controller Status LEDs

LED Activity	Type	Color	Description
Steady ON	Fault	Yellow	MCU Not Programmed
Steady ON	Fault	Red	MCU Hardware Failure
1 Flash	Fault	R–Y–G	Invalid Configuration
2 Flash	Fault	R–Y–G	Incompatible Software
1 Flash	Fault	R–Y	I/O Exp Board Communications Fail
1 Flash	Mode	G–Y	Service / Test Mode Active
Rapid Flash	Fault	Red	A2L Mitigation – Refrigerant Leak
1 Flash	Fault	Red	Compressor #1 High Pressure
2 Flash	Fault	Red	Compressor #1 Low Pressure
3 Flash	Fault	Red	Compressor #1 Suction Temp Sensor Fail
4 Flash	Fault	Red	Compressor #1 Low Suction Temp
5 Flash	Fault	Red	Compressor #2 High Pressure
6 Flash	Fault	Red	Compressor #2 Low Pressure
7 Flash	Fault	Red	Compressor #2 Suction Temp Sensor Fail
8 Flash	Fault	Red	Compressor #2 Low Suction Temp
9 Flash	Fault	Red	A2L Mitigation – Control Board Without Power
10 Flash	Fault	Red	Compressor #1 High Discharge Temp
11 Flash	Fault	Red	Compressor #2 High Discharge Temp
Rapid Flash	Mode	Yellow	A2L Mitigation – Refrigerant Sensor Fail
1 Flash	Fault	Yellow	Compressor Low Voltage Brownout
2 Flash	Fault	Yellow	Freeze Fault Detect (FFD)
3 Flash	Fault	Yellow	Control Temp Sensor Fail
4 Flash	Fault	Yellow	Entering Water Temp Sensor Fail
5 Flash	Fault	Yellow	Leaving Water Temp Sensor Fail
6 Flash	Fault	Yellow	Relative Humidity Sensor Fail
7 Flash	Fault	Yellow	Condensate Overflow
8 Flash	Fault	Yellow	Space Temp Sensor Fail
9 Flash	Fault	Yellow	Return Air Temp Sensor Fail
Rapid Flash	Mode	Green	Emergency Shutdown
1 Flash	Mode	Green	No Call for Heating / Cooling / Dehumidification
2 Flash	Mode	Green	Call for Cooling
3 Flash	Mode	Green	Call for Heating

LED Activity	Type	Color	Description
4 Flash	Mode	Green	Call for Fan Only
5 Flash	Mode	Green	Unoccupied Mode Active
6 Flash	Mode	Green	Call for Dehumidification
7 Flash	Mode	Green	Low Entering Water Temp
8 Flash	Mode	Green	HGR Low Return Air Temp Cutout
9 Flash	Mode	Green	WSE Low Temp Cutout

Table 23: MT2310 I/O Expansion Board Status LEDs

LED Activity	Type	Color	Description
1 Flash	Mode ¹	Green	Variable Speed Fan OFF
2 Flash	Mode ¹	Green	Variable Speed Fan ON: 0 to 20%
3 Flash	Mode ¹	Green	Variable Speed Fan ON: 21 to 30%
4 Flash	Mode ¹	Green	Variable Speed Fan ON: 31 to 40%
5 Flash	Mode ¹	Green	Variable Speed Fan ON: 41 to 50%
6 Flash	Mode ¹	Green	Variable Speed Fan ON: 51 to 60%
7 Flash	Mode ¹	Green	Variable Speed Fan ON: 61 to 70%
8 Flash	Mode ¹	Green	Variable Speed Fan ON: 71 to 80%
9 Flash	Mode ¹	Green	Variable Speed Fan ON: 81 to 90%
10 Flash	Mode ¹	Green	Variable Speed Fan ON: 91 to 100%
Steady ON	Fault	Yellow	MCU Not Programmed
Steady ON	Fault	Red	MCU Hardware Failure
1 Flash	Fault	R-Y-G	Invalid Configuration
2 Flash	Fault	R-Y-G	Incompatible Software
1 Flash	Fault	R-Y	Base Board Communications Failure
Rapid Flash	Fault	Red	A2L Mitigation - Alarm Condition

¹ When the BACnet network is overriding the fan speed DIP switch selection, the LED interval color will be yellow instead of OFF.

Table 24: Priority Level of Faults and Modes with Resets

Alarm Enumeration (BACnet)	Fault	Indication	Reset ¹
1	No Alarm	Normal operation	NA
2	MT2310 Communication Failure	Single compressor unit with SW #8 set to ON position	A
3	Incompatible Software	Incorrect Software Part or Version Numbers	P
4	Invalid Configuration	Base & IO Exp Application Mismatch or MT2310 detected but not required (SW #8)	P
5	A2L Alarm	A2L refrigerant leak detected	A
6	A2L Error - Power	A2L mitigation control is not powered	A
7	Compressor Low Voltage	"Brownout" condition exists	A
8	Comp #1 High Pressure	Compressor #1 high pressure switch opened	T,N
9	Comp #2 High Pressure	Compressor #2 high pressure switch opened	T,N
10	Comp #1 Low Pressure	Compressor #1 low pressure switch opened	T,N

Alarm Enumeration (BACnet)	Fault	Indication	Reset ¹
11	Comp #2 Low Pressure	Compressor #2 low pressure switch opened	T,N
12	Comp #1 Suction Temp Sensor	Compressor #1 suction temp sensor failure	N
13	Comp #2 Suction Temp Sensor	Compressor #2 suction temp sensor failure	N
14	Leaving Water Temp (LWT) Sensor	LWT sensor not present (SW #4 = ON)	N
15	Freeze Fault Detect (FFD)	LWT sensor temp below freeze setpoint (SW #4 = ON)	T,N
16	Comp #1 Low Suction Temp (ST1)	ST1 sensor temp below minimum setpoint	A,T,N ²
17	Comp #2 Low Suction Temp (ST2)	ST2 sensor temp below minimum setpoint	A,T,N ²
18	A2L Error - Sensor	A2L sensor lost communication or reported failure	A
19	Control Temp Sensor Failure	Room Temp and Return Air Temp sensor failures	N
20	Entering Water Temp (EWT) Sensor Failure	EWT sensor reading "out of range"	N
21	Room Temp Sensor Failure	Room temp sensor reading "out of range"	N
22	Return Air Temp Sensor Failure	RAT sensor reading "out of range"	N
23	Space RH Sensor Failure	Space RH sensor reading "out of range"	N
24	Low Entering Water Temp (EWT)	EWT sensor reading below minimum setpoint	A
25	Condensate Overflow	Condensate overflow sensor indicates water present	A,N
26	Waterside Economizer (WSE) Low Temp	WSE temp sensor reading below minimum setpoint	A

NOTE 1: "A" = Auto Reset, "T" = Tenant Override Button Reset, "N" = Network Reset, "P" = power cycle only

NOTE 2: Low suction temperature faults have "Intelligent Reset" logic - 3 faults in a 24 hour period disables the auto reset function.

Table 25: I/O Expansion Module Configuration Switch

Fan Speed Row	Switch 1	Switch 2	Switch 3	Fan Only ¹	Cool Stage 1	Cool Stage 2	Heat Stage 1	Heat Stage 2
1	OFF	OFF	OFF	20%	80%	100%	80%	100%
2	ON	OFF	OFF	20%	70%	90%	70%	90%
3	OFF	ON	OFF	20%	60%	80%	60%	80%
4	ON	ON	OFF	20%	50%	70%	50%	70%
5	OFF	OFF	ON	20%	65%	85%	65%	85%
6	ON	OFF	ON	20%	55%	75%	55%	75%
7	OFF	ON	ON	20%	50%	65%	50%	65%
8	ON	ON	ON	20%	50%	55%	50%	55%

NOTE: When in Fan Only (SW4) mode, OFF = 20% and ON = Cool Stage 1 speed (heat or cool mode fan speeds not affected).

Fan Speed Configuration Switches (SW1, SW2, SW3)

Configuration Switches on the I/O expansion module allow maximum CFM settings to be field adjustable. Fan speed control optimizes unit fan speed (CFM) based on thermostat/room sensor inputs. The fan speed switch allows for manually setting an optimal CFM specific to the application requirements. Each setting on the fan speed configuration switches represents settings 1-8. See Table 25 on page 54 for the complete list of fan speed selector switch settings. Additionally SW3 can be used to reduce the CFM setting. Setting the SW3 to On will reduce the out put signal by 15% of it's maximum value, with a minimum output of 50% of the maximum value while heating, cooling, or dehumidifying.

BACnet Communication Module

On units with an optional BACnet communication module, fan speeds can be set through network communications to 1% resolution of duty cycle. For hydronic or compressorized modes, the range is 50-100%, and for fan only mode, the range is 10-100%. When enabled, the network fan speed settings will override the local configuration switches. When the MT2310 status LED interval is yellow instead of Off, this indicates that the network is overriding the fan speed settings.

Variable CFM

All units have the capability to deliver variable CFM based on the thermostat wiring. By using a multi-stage wall thermostat, the

unit can deliver lower CFM as the space temperature is satisfied. For example, unit size 024 with SW1 and SW2 switches at setting 3 and a 3-stage cooling wall thermostat will deliver 650 CFM at stage 1 cooling, 700 CFM at stage 2 cooling and 800 CFM at stage 3 cooling. All of this is accomplished by wiring the thermostat to the appropriate terminal on the MicroTech controller terminal strip. The variable CFM feature allows for improved humidity levels by increasing latent cooling capacity through reduced CFM. Here, we are attempting to satisfy cooling at the lowest airflow, 650 CFM, but having the capability to deliver higher airflow, 800 CFM, if needed.

Fan Only Speed Configuration Switch (SW4)

In addition to the SW1, SW2, and SW3 switches, all units have the capability to set Fan Only CFM values independent to those associated with other modes of operation using the SW4 switch. When the SW4 switch is Off the fan only speed will be fixed at the speed associated with a low 20% duty cycle output. When the SW4 switch is On, the Fan Only speed will match the speed for the Stage 1/Low CFM output.

For example, unit size 036 with SW1 and SW2 switches set at Setting #3, SW3 set at Off, and SW4 set at On, will deliver 1200 CFM at stage 2 compressor operation mode, 1050 CFM at stage 1 compressor operation, 1350 CFM in electric heat mode, 1050 CFM in fan only mode, 975 CFM in dehumidification mode, 1050 CFM in hydronic heat mode, and 1050 CFM in waterside economizer mode.

Figure 56: SW1 & SW2 Location on the I/O Expansion Module

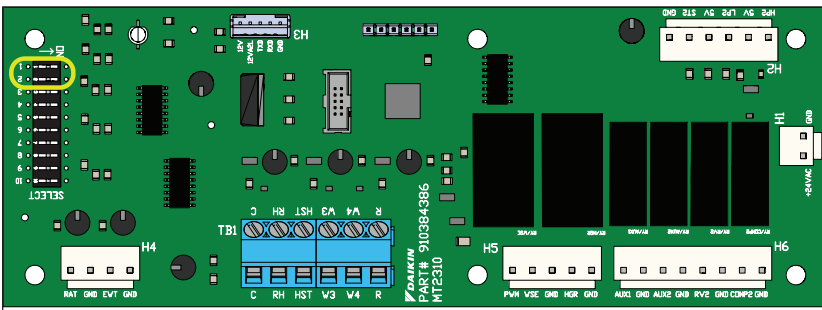

Table 26: Representative Data for Size 036, Constant CFM

Unit Size	Fan Setting	Maximum ESP (in. wg.) ²	¹ Low CFM Heat	¹ High CFM Heat	¹ Low CFM Cool	¹ High CFM Cool	Dehumidification	Fan Only SW4 On	Fan Only SW4 Off	Hydronic Heat
036	Fan Speed 1	0.5	1200	1350	1200	1350	1125	1200	770	1205
	Fan Speed 2		1125	1280	1125	1280	1050	1125	770	1135
	Fan Speed 3		1050	1205	1050	1205	975	1050	770	1060
	Fan Speed 4		975	1135	975	1135	975	975	770	990
	Fan Speed 5		1088	1240	1088	1240	1013	1088	770	1095
	Fan Speed 6		1013	1170	1013	1170	975	1013	770	1025
	Fan Speed 7		975	1095	975	1095	975	975	770	990
	Fan Speed 8		975	1025	975	1025	975	975	770	990

¹ The unit is capable of high-low fan performance through the use of a 2-stage thermostat wired to specific terminals for High-Low CFM fan performance. Standard operation with a 1-stage thermostat is indicated as High CFM fan performance.

² Applications up to 1.0" ESP (in. wg.) are possible. However, increased fan noise should be anticipated and appropriate noise attenuation should be considered.

MT2300 Controller with an Optional BACnet® Communication Module



For installation and operation information on MT2300 unit controller and other ancillary components, see:

- OM 1364 - MT2300 Unit Controller with MT2310 I/O Expansion Board MicroTech® Controller
- IM 955 - MicroTech Wall Sensor For Use with Microtech SmartSource Unit Controller
- IM 956 - Temperature Sensors for Units with MicroTech®III or MT2300 Unit Controller and LonWorks® or BACnet® Communication Module
- IM 1363 - MicroTech MT2300 Water Source Heat Pump Unit Controller BACnet® MS/TP Communication Module
- ED 19129 - MicroTech MT2300 Water Source Heat Pump Unit Controller BACnet® Protocol Information

Daikin Applied water source heat pumps are available with an optional BACnet MS/TP communication module that is designed to communicate over a BACnet MS/TP communications network to a building automation system (BAS). It can be factory or field-installed.

The unit controller is programmed and tested with all the logic required to monitor and control the unit. An optional wall sensor may be used with the communication module to provide limited local control of the water source heat pump. The unit controller monitors water and air temperatures and passes information to the communication module. The module communicates with the BAS, to provide network control of the water source heat pump.

The module makes operational data and commands available on a communications network using BACnet objects and properties:

- The network cable is a shielded twisted-pair cable
- Network communications run up to 76.8 Kbps
- DIP switches on the controller enable the MS/TP MAC address to be set in the range 0-127
- Four green status LEDs on the communication module indicate communication activity on the MS/TP communication network and with the unit controller

The MT2300 unit controller with BACnet MS/TP communication module orchestrates the following unit operations:

- Enable heating and cooling to maintain setpoint based on a room sensor
- Enable fan and compressor operation
- Monitors all equipment protection controls
- Monitors room and discharge air temperatures
- Monitors leaving water temperature
- Relays status of all vital unit functions

The MT2300 unit controller with an optional communication module includes:

- Return Air Temperature sensor (RAT) (field-installed)
- Discharge Air Temperature sensor (DAT) (field-installed)
- Leaving Water Temperature sensor (LWT)

NOTICE

Refer to IM 956 for details to install RAT & DAT sensors.

The communication module provides access to setpoints for operational control.

Available wall sensors include:

- Room sensor with LED status and tenant override button
- Room sensor with LED status, tenant override button, and $\pm 5^{\circ}\text{F}$ setpoint adjustment
- Room sensor with LED status, tenant override button, 55° to 95°F (13° to 35°C) setpoint adjustment

Maintenance

Troubleshooting

Table 27: Troubleshooting Refrigeration Circuit

Symptom	Head Pressure	Suction Pressure	Compressor Amp Draw	Super Heat	Subcooling	Air Temp Differential	Water (Loops) Temp Differential	Safety Lock Out
Charge	Low	Low	Low	High	Low	Low	Low	Low Pressure
Undercharge System (Possible Leak)								
Overcharge System	High	High	High	Normal	High	Normal/Low	Normal	High Pressure
Low Air Flow Heating	High	High	High	High/Normal	Low	High	Low	High Pressure
Low Air Flow Cooling	Low	Low	Low	Low/Normal	High	High	Low	Low Temp
Low Water Flow Heating	Low/Normal	Low/Normal	Low	Low	High	Low	High	Low Temp
Low Water Flow Cooling	High	High	High	High	Low	Low	High	High Pressure
High Air Flow Heating	Low	Low	Low	Low	High	Low	Low	Low Temp
High Air Flow Cooling	Low	High	Normal	High	Low	Low	Normal	High Pressure
High Water Flow Heating	Normal	Low	Normal	High	Normal	Normal	Low	High Pressure
High Water Flow Cooling	Low	Low	Low	Low	High	Normal	Low	Low Temp
TXV Restricted	High	Low	Normal/Low	High	High	Low	Low	High Pressure/ Low Temp

Troubleshooting the Water Source Heat Pump Unit

Compressor runs in short cycle

- Check wiring - loose or broken and check for faulty connection
- Check relays and contacts, also capacitor and wiring.
- Check high pressure switch, low pressure switch and low temperature switch to see if unit is cycling on the safety.
- Check to see if the reversing valve is not hung up and is operating correctly.
- Check condensate overflow switch in cool/dehumidification mode of operation.
- Check thermostat or room sensor for proper location

Neither fan, nor compressor runs and all LED lights are off

- Unit control, check thermostat for correct wiring or faulty thermostat.
- Wire may be loose or broken. Replace or tighten wires.
- Fuse may be blown, circuit breaker is open.
- Low voltage, check power supply voltage.

Fan operates, compressor does not

- Check wiring - loose or broken and check for bad connection.
- High or Low pressure lockout:
 - a. Cool mode, check water flow

b. Heating mode, check air flow

c. Check reversing valve for proper valve position

- Check compressor overload - make sure it is closed.
- Check compressor to ground, or for internal short to ground.
- Compressor winding may be open. Check continuity with ohm meter.

Compressor attempts to start but does not



- Check compressor wiring for defective wiring or loose connection.
- Check for defective compressor internal windings with ohm meter.
- Check for faulty compressor capacitor.
- Check for lock rotor amp draw.

Insufficient cooling or heating

- Check thermostat for improper location.
- Check for proper air flow - filter could be dirty.
- Check blower assembly for dirt or faulty fan motor capacity.
- Check for low refrigerant charge.
- Check amp draw on blower assembly.
- Check for proper water flow and delta T (°F).

Refrigerant Information

Refrigerant Guidelines

 WARNING	
	<p>This unit contains R-32, a class A2L refrigerant that is flammable. This unit should only be installed, serviced, repaired, and disposed of by qualified personnel licensed or certified in their jurisdiction to work with R-32 refrigerant. Installation and maintenance must be done in accordance with this manual. Improper handling of this equipment can cause equipment damage or personal injury.</p>
<p>For installation only in locations not accessible to the general public.</p> <p>Be aware that R-32 refrigerant may not contain an odor. Place in a well ventilated area to prevent accumulation of refrigerant. When installing the unit in a small room, take measures to keep the refrigerant concentration from exceeding allowable safety limits. Excessive refrigerant leaks, in the event of an accident in a closed ambient space, can lead to oxygen deficiency.</p> <p>Do not pierce or burn this unit.</p> <p>Never use an open flame during service or repair. Never store in a room with continuously operating ignition sources (for example: open flames, an operating gas appliance, or an operating electric heater.), where there is ignitable dust suspension in the air, or where volatile flammables such as thinner or gasoline are handled.</p> <p>Only use pipes, nuts, and tools intended for exclusive use with R-32 refrigerant in compliance with national codes (ASHRAE15 or IRC).</p> <p>Do not mix air or gas other than R-32 in the refrigerant system. If air enters the refrigerant system, an excessively high pressure results, which may cause equipment damage or injury.</p> <p>Do not use means to accelerate the defrosting process or to clean, other than those recommended by the manufacturer.</p>	

Lubrication

R-32 should be used only with polyolester (POE) oil. The HFC refrigerant components in R-32 will not be compatible with mineral oil or alkylbenzene lubricants. R-32 systems will be charged with the OEM recommended lubricant, ready for use with R-32.

Competence of Personnel

Information of procedures additional to usual information for refrigerating equipment installation, repair, maintenance and decommission procedures is required when equipment with flammable refrigerants is affected.

The training of these procedures is carried out by national training organizations or manufacturers that are accredited to teach the relevant national competency standards that may be set in legislation. The achieved competence should be documented by a certificate.

WARNING

Service on this equipment is to be performed by qualified refrigeration personnel familiar with equipment operation, maintenance, correct servicing procedures, and the safety hazards inherent in this work. Causes for repeated tripping of equipment protection controls must be investigated and corrected. Disconnect all power before doing any service inside the unit. If refrigerant leaks from the unit, there is a potential danger of suffocation since refrigerant will displace the air in the immediate area. Servicing this equipment must comply with the requirements of all applicable industry related published standards and local, state and federal, statutes, regulations and codes in regards to refrigerant reclamation and venting. Avoid exposing refrigerant to an open flame or other ignition source.

Maintaining and servicing R-32 refrigerant should only be performed as recommended by this manual and by personnel licensed or certified in their jurisdiction to handle A2L refrigerants. Dismantling the unit and treatment of the refrigerant, oil, and additional parts must be done in accordance with the relevant local, state, and national regulations.

Only use tools meant for use on R-32 refrigerant, such as a gauge manifold, charge hose, gas leak detector, reverse flow check valve, refrigerant charge base, vacuum gauge, or refrigerant recovery equipment.

The following guidelines align with UL Standard 60335-2-40.

Maintenance and Repair

- Portable equipment shall be repaired outside or in a workshop specially equipped for servicing units with **FLAMMABLE REFRIGERANTS**.
- Ensure sufficient ventilation at the repair place.
- Be aware that malfunction of the equipment may be caused by refrigerant loss and a refrigerant leak is possible.
- Discharge capacitors in a way that won't cause any spark. The standard procedure to short circuit the capacitor terminals usually creates sparks.
- When brazing is required, the following procedures shall be carried out in the right order:
 - Remove the refrigerant. If the recovery is not required by national regulations, drain the refrigerant to the outside. Take care that the drained refrigerant will not cause any danger. In doubt, one person should guard the outlet. Take special care that drained refrigerant will not float back into the building.
 - Evacuate the refrigerant circuit.
 - Remove parts to be replaced by cutting, not by flame.
 - Purge the braze point with nitrogen during the brazing procedure.
 - Carry out a leak test before charging with refrigerant.
- Reassemble sealed enclosures accurately. If seals are worn, replace them.
- Check safety equipment before putting into service.

Checks to the refrigerating equipment

Where electrical components are being changed, they shall be fit for the purpose and to the correct specification. At all times

the manufacturer's maintenance and service guidelines shall be followed. If in doubt, consult the manufacturer's technical department for assistance.

The following checks shall be applied to installations using FLAMMABLE REFRIGERANTS:

- the actual REFRIGERANT CHARGE is in accordance with the room size within which the refrigerant containing parts are installed;
- the ventilation machinery and outlets are operating adequately and are not obstructed;
- if an indirect refrigerating circuit is being used, the secondary circuit shall be checked for the presence of refrigerant;
- marking to the equipment continues to be visible and legible. Markings that are illegible shall be corrected; and
- refrigerating pipe or components are installed in a position where they are unlikely to be exposed to any substance which may corrode refrigerant containing components, unless the components are constructed of materials which are inherently resistant to being corroded or are suitably protected against being so corroded.

Checks to electrical devices

Repair and maintenance to electrical components shall include initial safety checks and component inspection procedures. If a fault exists that could compromise safety, then no electrical supply shall be connected to the circuit until it is satisfactorily dealt with. If the fault cannot be corrected immediately but it is necessary to continue operation, an adequate temporary solution shall be used. This shall be reported to the owner of the equipment so all parties are advised.

Initial safety checks shall include:

- that capacitors are discharged: this shall be done in a safe manner to avoid possibility of sparking;
- that no live electrical components and wiring are exposed while charging, recovering or purging the system; and
- that there is continuity of earth bonding.

Sealed electrical and intrinsically safe components

- All sealed electrical components shall be replaced.
- All intrinsically safe components must be replaced.

Cabling

- Check that cabling will not be subject to wear, corrosion, excessive pressure, vibration, sharp edges or any other adverse environmental effects. The check shall also take into account the effects of aging or continual vibration from sources such as compressors or fans.

Leak Detection

Under no circumstances shall potential sources of ignition be used in the searching for or detection of refrigerant leaks. NEVER use the following when attempting to detect flammable refrigerant leaks:

- A halide torch (or any other detector using a naked flame); or
- Substances containing chlorine.

Detection of flammable refrigerants

The following leak detection methods are deemed acceptable for all refrigerant systems:

- Electronic leak detectors may be used to detect refrigerant leaks. For FLAMMABLE REFRIGERANTS, the sensitivity of electronic leak detectors may not be adequate, or may need re-calibration. (Detection equipment shall be calibrated in a refrigerant-free area.) Ensure that the detector is not a potential source of ignition and is suitable for the refrigerant used. Leak detection equipment shall be set at a percentage of the LFL of the refrigerant and shall be calibrated to the refrigerant employed, and the appropriate percentage of gas (25% maximum) is confirmed.
- Leak detection fluids are also suitable for use with most refrigerants but the use of detergents containing chlorine shall be avoided as the chlorine may react with the refrigerant and corrode the copper pipe-work. Examples of leak detection fluids are:
 - bubble method; or
 - fluorescent method agents.
- If a leak is suspected, all open flames shall be removed/ extinguished.
- If a leakage of refrigerant is found which requires brazing, all of the refrigerant shall be recovered from the system, or isolated (by means of shut off valves) in a part of the system remote from the leak. Removal of refrigerant shall be according to instructions in "[Pressure Testing and Refrigerant Evacuation](#)".

Pressure Testing and Refrigerant Evacuation

- Make sure that air or any matter other than R-32 refrigerant does not get into the refrigeration cycle.
- If refrigerant gas leaks occur, ventilate the room/area as soon as possible.
- R-32 should always be recovered and never released directly into the environment.
- Only use tools meant for use on R-32 refrigerant (such as a gauge manifold, charging hose, or vacuum pump adapter).

Removal and evacuation

When breaking into the refrigerant circuit to make repairs, or for any other purpose, conventional procedures shall be used. However, for flammable refrigerants it is important that best practice be followed, since flammability is a consideration.

- The following procedure shall be adhered to:
 - i. safely remove refrigerant following local and national regulations - see "[Recovery](#)" section;
 - ii. purge the circuit with inert gas;
 - iii. evacuate;

- iv. purge with inert gas;
- v. open the circuit by cutting (if flammable refrigerant) or brazing.
- The refrigerant charge shall be recovered into the correct recovery cylinders according to local and national codes. For equipment containing flammable refrigerants, the system shall be purged with oxygen-free nitrogen to render the equipment safe for flammable refrigerants. This process might need to be repeated several times.
- Compressed air or oxygen shall not be used for purging refrigerant systems.
- For equipment containing flammable refrigerants, refrigerants purging shall be achieved by breaking the vacuum in the system with oxygen-free nitrogen and continuing to fill until the working pressure is achieved, then venting to atmosphere, and finally pulling down to a vacuum.
- When the final oxygen-free nitrogen charge is used, the system shall be vented down to atmospheric pressure to enable work to take place.
- Ensure that the outlet for the vacuum pump is not close to any potential ignition sources and that ventilation is available.

Handling and Storage

Conditions for safe storage

- Requirements to be met by storerooms and receptacles:
 - Store only in unopened original receptacles
 - Store in a cool and dry location
- Further information about storage conditions:
 - Keep container tightly sealed
 - Store in cool, dry conditions in well sealed receptacle
 - Protect from heat and direct sunlight
- Maximum storage temperature: 40°C (104°F)

Fire and explosion protection information

Open and handle refrigerant receptacle with care. Keep ignition sources away. Do not smoke. Protect against electrostatic charges. Waste air is to be released into the atmosphere only via suitable separators.

Commissioning

- Ensure that the floor area is sufficient for the refrigerant charge or that the ventilation duct is assembled in a correct manner.
- Connect the pipes and carry out a leak test before charging with refrigerant.
- Check safety equipment before putting into service.

Charging procedures

In addition to conventional charging procedures and specific unit charging guidelines, the following requirements shall be followed:

- Ensure that contamination of different refrigerants does not occur when using charging equipment.
- Hoses or lines shall be as short as possible to minimize the amount of refrigerant contained in them.
- Cylinders shall be kept in an appropriate position according to the instructions.
- Ensure that the refrigerating system is earthed prior to charging the system with refrigerant.
- Label the system when charging is complete (if not already).
- Extreme care shall be taken not to overfill the refrigerating system.
- Prior to recharging the system, it shall be pressure-tested with the appropriate purging gas. The system shall be leak-tested on completion of charging but prior to commissioning. A follow up leak test shall be carried out prior to leaving the site.

Decommissioning

- If the safety is affected when the equipment is put out of service, the refrigerant charge shall be removed before decommissioning.
- Ensure sufficient ventilation at the equipment location.
- Be aware that malfunction of the equipment may be caused by refrigerant loss and a refrigerant leak is possible.
- Discharge capacitors in a way that won't cause any spark.
- Remove the refrigerant according to details in "Recovery" section. If recovery is not required by national regulations, drain the refrigerant to the outside. Take care that the drained refrigerant will not cause any danger. In doubt, one person should guard the outlet. Take special care that drained refrigerant will not float back into the building.
- Ensure all isolation valves on the equipment are closed off.

Labeling

Equipment shall be labeled stating that it has been de-commissioned and emptied of refrigerant. The label shall be dated and signed. For equipment containing FLAMMABLE REFRIGERANTS, ensure that there are labels on the equipment stating the equipment contains FLAMMABLE REFRIGERANT.

Recovery

When removing refrigerant from a system, either for servicing or decommissioning, it is recommended good practice that all refrigerants are removed safely. When transferring refrigerant into cylinders, ensure that only appropriate refrigerant recovery cylinders are employed. Ensure that the correct number of cylinders for holding the total system charge is available. All cylinders to be used are designated for the recovered refrigerant and labeled for that refrigerant (i.e., special cylinders for the recovery of refrigerant). Cylinders shall be complete with pressure-relief valve and associated shut-off valves in good working order. Empty recovery cylinders are evacuated and, if possible, cooled before recovery occurs.

The recovery equipment shall be in good working order with a

set of instructions concerning the equipment that is at hand and shall be suitable for the recovery of all appropriate refrigerants including, when applicable, FLAMMABLE REFRIGERANTS. If in doubt, the manufacturer should be consulted. In addition, a set of calibrated weighing scales shall be available and in good working order. Hoses shall be complete with leak-free disconnect couplings and in good condition. Before using the recovery machine, check that it is in satisfactory working order, has been properly maintained and that any associated electrical components are sealed to prevent ignition in the event of a refrigerant release. Consult manufacturer if in doubt.

The recovered refrigerant shall be returned to the refrigerant supplier in the correct recovery cylinder, and the relevant waste transfer note arranged. Do not mix refrigerants in recovery units and especially not in cylinders.

If compressors or compressor oils are to be removed, ensure that they have been evacuated to an acceptable level to make certain that FLAMMABLE REFRIGERANT does not remain within the lubricant. The evacuation process shall be carried out prior to returning the compressor to the suppliers. Only electric heating to the compressor body shall be employed to accelerate this process. When oil is drained from a system, it shall be carried out safely.

Recovery procedure

Before carrying out this procedure, it is essential that the technician is completely familiar with the equipment and all its detail. It is recommended good practice that all refrigerants are recovered safely.

Prior to the task being carried out, an oil and refrigerant sample shall be taken in case analysis is required prior to re-use of recovered refrigerant.

It is essential that electrical power is available before the task is commenced.

1. Become familiar with the equipment and its operation.
2. Isolate system electrically.
3. Before attempting the procedure, ensure that
 - mechanical handling equipment is available, if required, for handling refrigerant cylinders;
 - all personal protective equipment is available and being used correctly;
 - the recovery process is supervised at all times by a competent person;
 - recovery equipment and cylinders conform to the appropriate standards.
4. Pump down refrigerant system, if possible.
5. If a vacuum is not possible, make a manifold so that refrigerant can be removed from various parts of the system.
6. Make sure that cylinder is situated on the scale before recovery takes place.
7. Start the recovery machine and operate in accordance with instructions.
8. Do not overfill cylinders (no more than 80% volume liquid

charge).

9. Do not exceed the maximum working pressure of the cylinder, even temporarily.
10. When the cylinders have been filled correctly and the process completed, make sure that the cylinders and the equipment are removed from site promptly and all isolation valves on the equipment are closed off.

Disposal

- Waste treatment method recommendation:
 - Must be specially treated adhering to official regulations
 - Incineration in an adequate incinerator is recommended
 - Uncleaned packaging disposal must be made according to official regulations
- Ensure sufficient ventilation at the working place
- The following procedure shall be adhered to:
 - i. safely remove refrigerant following local and national regulations - see "Recovery" section;
 - ii. evacuate the refrigerant circuit;
 - iii. purge the refrigerant circuit with nitrogen gas for 5 minutes;
 - iv. evacuate again; and
 - v. If compressors are to be removed, cut out the compressor and drain the oil.

Typical Refrigeration Cycles

Cooling Refrigeration Cycle

When the wall thermostat is calling for COOLING, the reversing valve is de-energized and directs the flow of the refrigerant (hot gas) leaving the compressor to the water-to-refrigerant heat exchanger. Here the heat is removed by the water and the hot gas condenses to become a liquid. The liquid then flows through a thermal expansion valve (TXV) and then to the air-to-refrigerant heat exchanger coil. The liquid then evaporates becoming a gas, at the same time absorbing heat and cooling the air passing over the surfaces of the coil. The refrigerant then flows as a low pressure gas through the reversing valve and back to the suction side of the compressor to complete the cycle.

Heating Refrigeration Cycle

When the wall thermostat is calling for HEATING, the reversing valve is energized and directs the flow of the refrigerant (hot gas) leaving the compressor to the air-to-refrigerant heat exchanger coil. Here the heat is removed by the air passing over the surfaces of the coil and the hot gas condenses to become a liquid. The liquid then flows through a TXV then to the water-to-refrigerant heat exchanger. The liquid then evaporates becoming a gas, at the same time absorbing heat and cooling the water. The refrigerant then flows as a low pressure gas through the reversing valve and back to the suction side of the compressor.

Figure 57: Cooling Mode

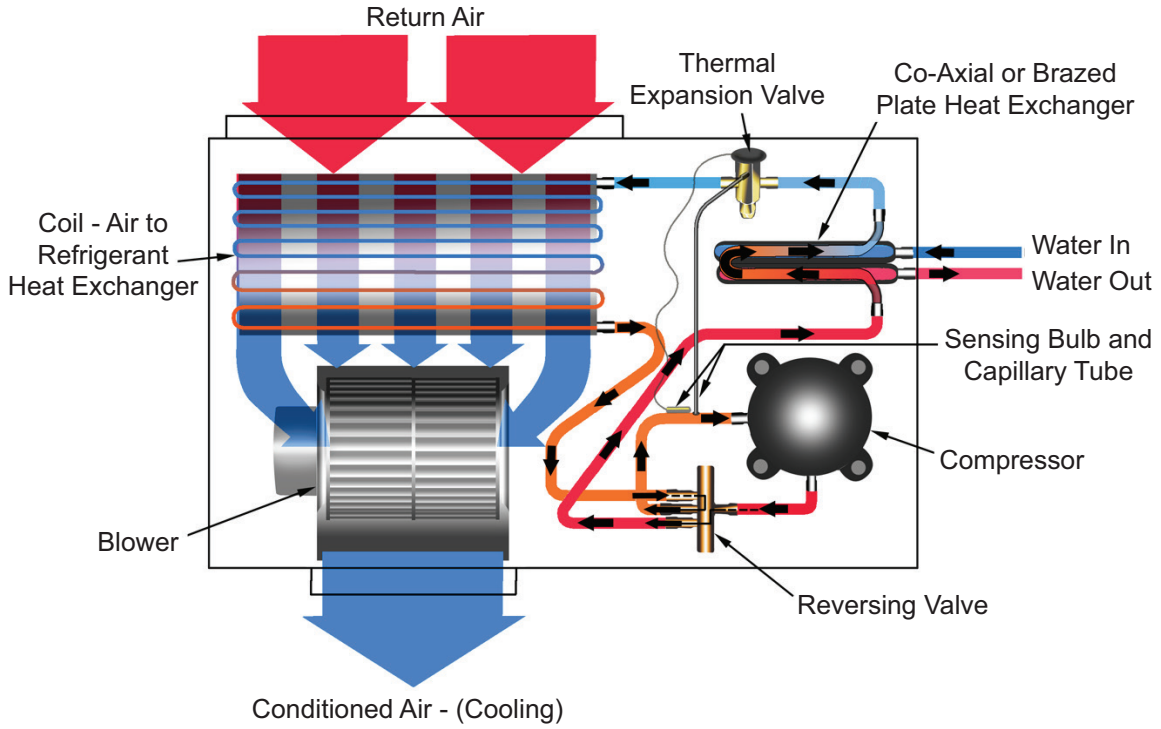
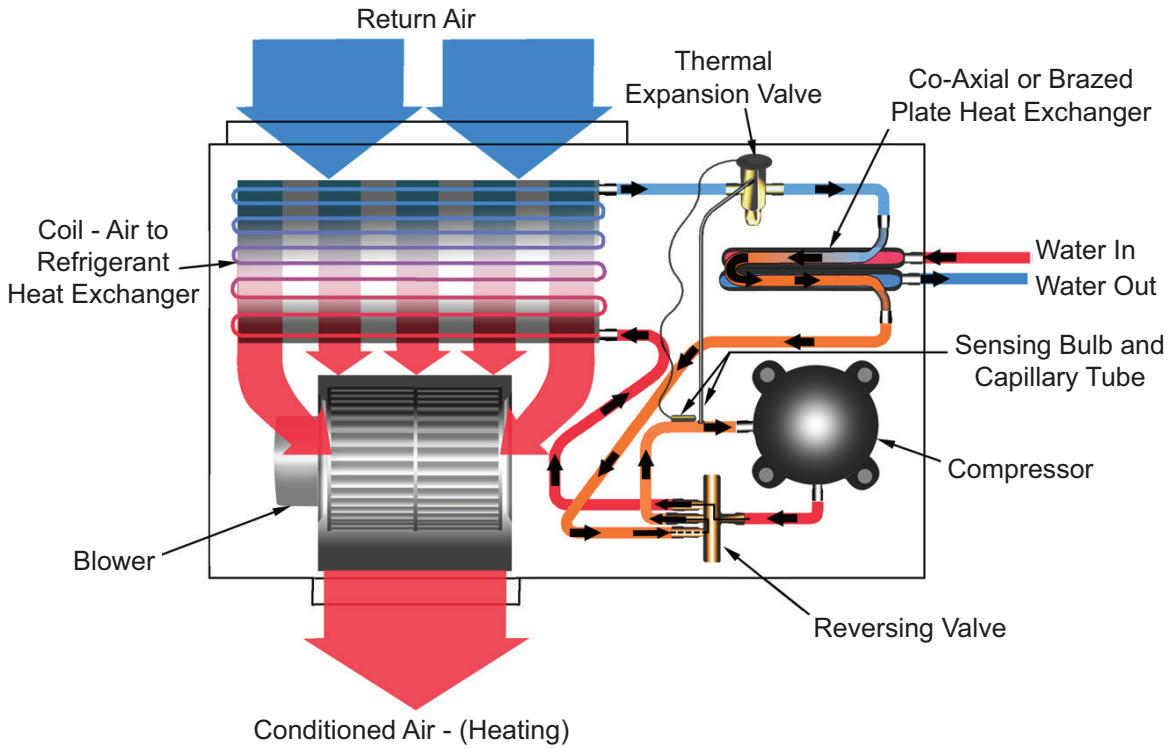

Figure 58: Heating Mode



Unit Check / Equipment Data

Installation Data

Job Name _____ Check Test Date: _____
 City _____ State _____ Zip _____
 Daikin Model # _____
 Daikin Serial # _____ Job site Unit ID # (HP #) _____
 General Contractor: _____ Mechanical Contractor: _____
 Technician Performing Start-Up: Name _____ Employer: _____
Complete equipment data from measurements taken at the locatons indicated on the drawing below.

Equipment Data

Flow Rate **EWP - LWP = ΔP**
 ① EWP - PSI In _____ minus ② LWP - PSI Out _____ equals ΔP _____
 The first step in finding GPM is to subtract leaving water pressure from entering water pressure. The difference between the two is referred to as ΔP. ΔP can be converted to GPM by looking in the equipment specifcation catalog.
Caution ΔP ≠ GPM
Note: A conversion table must be used to find GPM from (Delta) ΔP measurements.

Loop Fluid Temperature Rise / Drop through Coaxial Heat Exchanger **EWT - LWT = ΔT**
 ③ EWT - °F Out _____ minus ④ LWT - °F Out _____ equals Fluid ΔT _____
 ΔT is the rise or drop in the fluid temperature as it passes through the Coaxial.

Air Temperature Rise / Drop through the air coil **ΔT x CFM x 1.08 = BTUH Sensible**
 ⑤ EAT - °F In _____ minus ⑥ LAT - °F Out _____ equals Air ΔT _____

Note: Perform Check, Test and Start-Up in the Cooling Mode Only.

EWT - Entering Water Temperature EWP - Entering Water Pressure EAT - Entering Air Temperature Δ- Delta (Differential)
 LWT - Leaving Water Temperature LWP - Leaving Water Pressure LAT - Leaving Air Temperature CFM - Cubic Feet/Minute
 BTUH - British Thermal Units/Hour

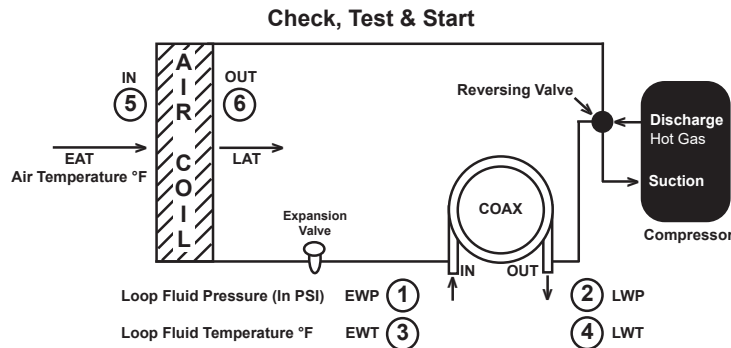

Commercial Check, Test and Start Worksheet
 (Complete all equipment measurements indicated for each unit per installation on page 2)

	Model	Serial #	H.P. #	EWT ③	LWT ④	EWP ①	LWP ②	EAT ⑤	LAT ⑥	Volts	Amps Cooling	Check Air Filter and Coil	Comments (more comments on back)
1.													
2.													
3.													
4.													
5.													
6.													
7.													
8.													
9.													
10.													
11.													
12.													
13.													
14.													
15.													
16.													
17.													
18.													
19.													
20.													
21.													
22.													
23.													
24.													
25.													
26.													
27.													
28.													
29.													
30.													
31.													
32.													
33.													
34.													
35.													
36.													
37.													
38.													
39.													
40.													
41.													
42.													

Limited Product Warranty



DAIKIN APPLIED AMERICAS INC. LIMITED PRODUCT WARRANTY (United States and Canada)

WARRANTY

Daikin Applied Americas Inc. dba Daikin Applied ("Company") warrants to contractor, purchaser and any owner of the product (collectively "Owner") that, subject to the exclusions set forth below Company, at its option, will repair or replace defective parts in the event any product manufactured by Company, including products sold under the brand name Daikin and used in the United States or Canada, proves defective in material or workmanship within twelve (12) months from initial startup or eighteen (18) months from the date shipped by Company, whichever occurs first. Authorized replacement parts are warranted for the remainder of the original warranty. All shipments of such parts will be made FOB factory, freight prepaid and allowed. Company reserves the right to select carrier and method of shipment. In addition, Company provides labor to repair or replace warranty parts during Company normal working hours on products with rotary screw compressors or centrifugal compressors. Warranty labor is not provided for any other products.

Company must receive the Registration and Startup Forms for products containing motor compressors and/or furnaces within ten (10) days of original product startup, or the ship date and the startup date will be deemed the same for determining the commencement of the warranty period and this warranty shall expire twelve (12) months from that date. For additional consideration, Company will provide an extended warranty(ies) on certain products or components thereof. The terms of the extended warranty(ies) are shown on a separate extended warranty statement.

No person (including any agent, sales representative, dealer or distributor) has the authority to expand the Company's obligation beyond the terms of this express warranty or to state that the performance of the product is other than that published by Company.

EXCLUSIONS

1. If free warranty labor is available as set forth above, such free labor does not include diagnostic visits, inspections, travel time and related expenses, or unusual access time or costs required by product location.
2. Refrigerants, fluids, oils and expendable items such as filters are not covered by this warranty.
3. This warranty shall not apply to products or parts : (a) that have been opened, disassembled, repaired, or altered, in each case by anyone other than Company or its authorized service representative; (b) that have been subjected to misuse, abuse, negligence, accidents, damage, or abnormal use or service; (c) that have not been properly maintained; (d) that have been operated or installed, or have had startup performed, in each case in a manner contrary to Company's printed instructions; (e) that have been exposed, directly or indirectly, to a corrosive atmosphere or material such as, but not limited to, chlorine, fluorine, fertilizers, waste water, urine, rust, salt, sulfur, ozone, or other chemicals, contaminants, minerals, or corrosive agents; (f) that were manufactured or furnished by others and/or are not an integral part of a product manufactured by Company; or (g) for which Company has not been paid in full.
4. This warranty shall not apply to products with rotary screw compressors or centrifugal compressors if such products have not been started, or if such startup has not been performed, by a Daikin Applied or Company authorized service representative.

SOLE REMEDY AND LIMITATION OF LIABILITY

THIS WARRANTY CONSTITUTES THE SOLE WARRANTY MADE BY COMPANY. COMPANY'S LIABILITY TO OWNER AND OWNER'S SOLE REMEDY UNDER THIS WARRANTY SHALL NOT EXCEED THE LESSER OF: (i) THE COST OF REPAIRING OR REPLACING DEFECTIVE PRODUCTS; AND (ii) THE ORIGINAL PURCHASE PRICE ACTUALLY PAID FOR THE PRODUCTS. COMPANY MAKES NO REPRESENTATION OR WARRANTY, EXPRESS OR IMPLIED, REGARDING PREVENTION OF MOLD/MOULD, FUNGUS, BACTERIA, MICROBIAL GROWTH, OR ANY OTHER CONTAMINATES. THIS WARRANTY IS GIVEN IN LIEU OF ALL OTHER WARRANTIES, INCLUDING, WITHOUT LIMITATION, THE IMPLIED WARRANTIES OF MERCHANTABILITY, FITNESS FOR A PARTICULAR PURPOSE, AND NON-INFRINGEMENT, WHICH ARE HEREBY DISCLAIMED. IN NO EVENT AND UNDER NO CIRCUMSTANCE SHALL COMPANY BE LIABLE TO OWNER OR ANY THIRD PARTY FOR INCIDENTAL, INDIRECT, SPECIAL, CONTINGENT, CONSEQUENTIAL, DELAY OR LIQUIDATED DAMAGES FOR ANY REASON, ARISING FROM ANY CAUSE WHATSOEVER, WHETHER THE THEORY FOR RECOVERY IS BASED IN LAW OR IN EQUITY, OR IS UNDER A THEORY OF BREACH CONTRACT OR WARRANTY, NEGLIGENCE, STRICT LIABILITY, OR OTHERWISE. THE TERM "CONSEQUENTIAL DAMAGE" INCLUDES, WITHOUT LIMITATION, THOSE DAMAGES ARISING FROM BUSINESS INTERRUPTION OR ECONOMIC LOSS, SUCH AS LOSS OF ANTICIPATED PROFITS, REVENUE, PRODUCTION, USE, REPUTATION, DATA OR CROPS.

ASSISTANCE

To obtain assistance or information regarding this warranty, please contact your local sales representative or a Daikin Applied office.

Form No. 933-430285Y-01-A (11/2023)
Part No. 043028500 Rev.0F

COMPLETE HVAC SYSTEM SOLUTIONS

SELF-CONTAINED | ROOFTOPS | COILS | CONDENSING UNITS
AIR HANDLERS | WATER-COOLED CHILLERS | AIR-COOLED CHILLERS
MODULAR CENTRAL PLANTS | SITELINE BUILDING CONTROLS
UNIT HEATERS | FAN COILS | AIR PURIFIERS | WATER SOURCE HEAT PUMPS
VARIABLE AIR VOLUME UNITS | UNIT VENTILATORS



13600 INDUSTRIAL PARK BLVD. | MINNEAPOLIS, MN 55441
1-800-432-1342 | 763-553-5330

LEARN MORE AT
DAIKINAPPLIED.COM

PART NUMBER: IM1378

© 2024 DAIKIN APPLIED | (800) 432.1342 | WWW.DAIKINAPPLIED.COM