

# MAVERICK® II COMMERCIAL PACKAGED ROOFTOP SYSTEMS



- HEATING AND COOLING
- R-32 REFRIGERANT
- MODELS: MPS030 - 050, 30 TO 50 TONS
- MICROTECH APP VERSION: 2506038105

# Table of Contents

<b>General Information</b> .....	<b>3</b>	<b>Outdoor Air Monitor</b> .....	<b>41</b>
Hazardous Information Messages .....	3	Thermal Dispersion Airflow Measurement Technology .....	41
R-32 (A2L) Information .....	4	<b>Unit Options</b> .....	<b>50</b>
Compliance Statements .....	4	<b>Wiring Diagrams</b> .....	<b>52</b>
Unit Labels .....	4	<b>Sequence of Operation</b> .....	<b>56</b>
<b>Electrical Installation</b> .....	<b>5</b>	Operating States .....	56
<b>Mechanical Installation</b> .....	<b>7</b>	Mechanical Cooling .....	57
Installer Responsibilities .....	7	Economizer .....	57
Receiving and Handling .....	7	<b>Check, Test, and Start</b> .....	<b>58</b>
Assembly Instructions .....	9	Servicing Control Panel Components .....	58
Lifting Guidance .....	14	Energy Recovery Wheel .....	61
Transit .....	15	<b>Final Control Settings</b> .....	<b>62</b>
Installing Ductwork .....	17	<b>R-32 Guidelines</b> .....	<b>63</b>
Spring Isolated Fans .....	19	<b>Maintenance</b> .....	<b>69</b>
<b>Optional Electric Heat</b> .....	<b>20</b>	Performing Service Maintenance .....	69
Electric Heater Design .....	20	Control Panel Components .....	71
<b>Optional Gas Heat</b> .....	<b>21</b>	Servicing Optional Electric Heater .....	73
Daikin Applied Tubular Heater Series Package Heater Module .....	21	Unit Storage .....	73
Gas Furnace Design .....	22	Bearing Lubrication .....	74
Installation .....	23	Energy Recovery Wheel Maintenance .....	75
Start-Up Procedures .....	28	Supply Fan .....	79
<b>Modulating Hot Gas Reheat</b> .....	<b>33</b>	Refrigerant Charge .....	79
<b>Optional Hot Water Heat</b> .....	<b>36</b>	<b>Service / Warranty Procedure</b> .....	<b>80</b>
<b>Optional Energy Recovery Wheel</b> .....	<b>38</b>	<b>Limited Product Warranty</b> .....	<b>81</b>
		<b>Warranty Registration Form</b> .....	<b>82</b>

©2026 Daikin Applied, Minneapolis, MN. All rights reserved throughout the world. This document contains the most current product information as of this printing. Daikin Applied Americas Inc. has the right to change the information, design, and construction of the product represented within the document without prior notice. For the most up-to-date product information, please go to [www.DaikinApplied.com](http://www.DaikinApplied.com).

™@ Maverick, MicroTech, and Daikin Applied are trademarks or registered trademarks of Daikin Applied Americas Inc. The following are trademarks or registered trademarks of their respective companies: BACnet from American Society of Heating, Refrigerating and Air-Conditioning Engineers, Inc.; Echelon, LonWorks, LonMark, and LonTalk from Echelon Corporation; Modbus from Schneider Electric; and Windows from Microsoft Corporation.

## General Information

This manual provides general information about the “J” vintage Daikin Applied Commercial Packaged Rooftop Unit model MPS. In addition to an overall description of the unit, it includes mechanical and electrical installation procedures, commissioning procedures, sequence of operation information, and maintenance instructions.

The MicroTech rooftop unit controller is available on “J” vintage rooftop units. For a detailed description of the MicroTech components, input/output configurations, field wiring options and requirements, and service procedures, see the operations manual.

### Unit Nameplate

The unit nameplate is located on the outside of the main control box door. It includes the unit model number, serial number, electrical characteristics, and refrigerant charge.

**Table 1: Unit Maximum/Minimum Specifications**

Maximum/Minimum Specifications	
Altitude	Maximum: 3500 meters
Water Pressure	Minimum: 0 PSI (0 kPa) Maximum: 120 PSI (827 kPa)
Water Temperature	Minimum: 100°F (38°C) Maximum: 210°F (99°C)

## Hazardous Information Messages

### CAUTION

Cautions indicate potentially hazardous situations, which can result in personal injury or equipment damage if not avoided.

### WARNING

Warnings indicate potentially hazardous situations, which can result in property damage, severe personal injury, or death if not avoided.

### WARNING

Warning indicates potentially hazardous situations for PVC (Polyvinyl Chloride) and CPVC (Chlorinated Polyvinyl Chloride) piping in chilled water systems. In the event the pipe is exposed to POE (Polyolester) oil used in the refrigerant system, the pipe can be chemically damaged and pipe failure can occur.

### DANGER

Dangers indicate a hazardous electrical situation which will result in death or serious injury if not avoided.

### DANGER

Dangers indicate a hazardous gas situation which will result in death or serious injury if not avoided.

### NOTICE



Notices give important information concerning a process, procedure, special handling, or equipment attributes.

**NOTE:** Indicates important details or clarifying statements for information presented.

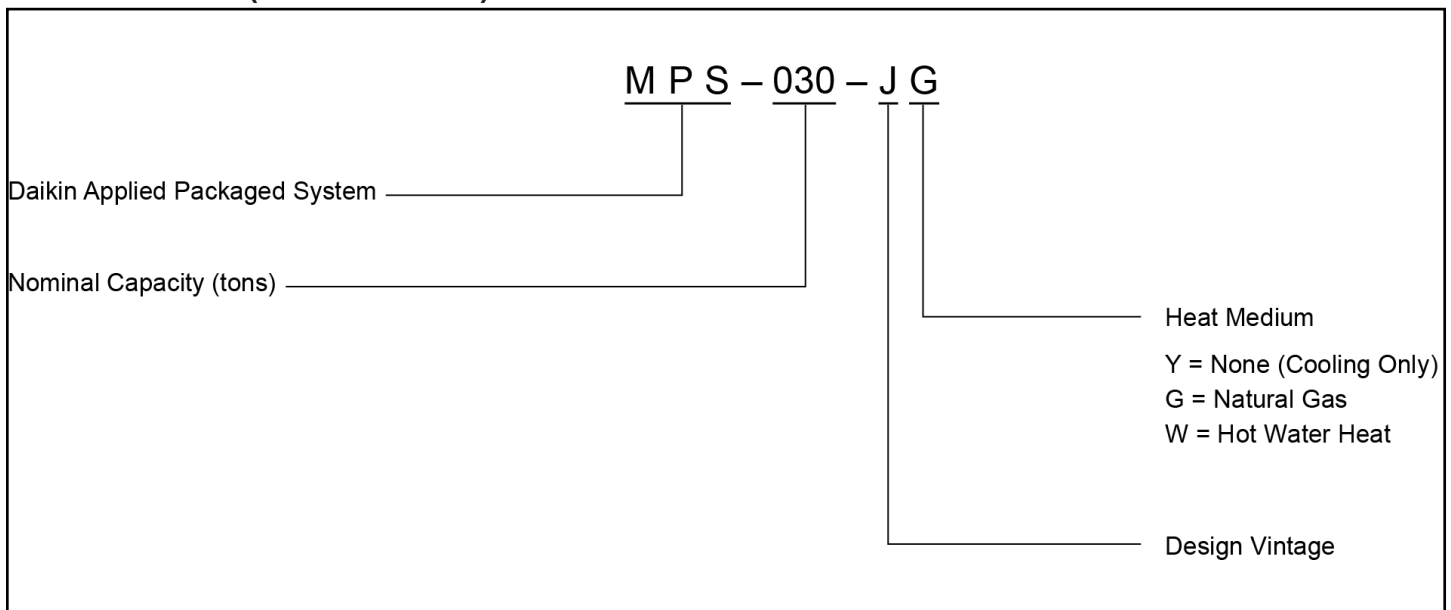
## Nomenclature (MPS 030–050)



## R-32 (A2L) Information

 <b>WARNING</b>	
	<p>This unit contains R-32, a class A2L refrigerant that is flammable. This unit should only be installed, serviced, repaired, and disposed of by qualified personnel licensed or certified in their jurisdiction to work with R-32 refrigerant. Installation and maintenance must be done in accordance with this manual. Improper handling of this equipment can cause equipment damage or personal injury.</p>
<p>Be aware that R-32 refrigerant may not contain an odor. Place in a well ventilated area to prevent accumulation of refrigerant. Excessive refrigerant leaks, in the event of an accident in a closed ambient space, can lead to oxygen deficiency.</p> <p>Do not pierce or burn this unit.</p> <p>Never use an open flame during service or repair. Never store in a room with continuously operating ignition sources (for example: open flames, an operating gas appliance, or an operating electric heater), where there is ignitable dust suspension in the air, or where volatile flammables such as thinner or gasoline are handled.</p> <p>Only use pipes, nuts, and tools intended for exclusive use with R-32 refrigerant in compliance with national codes (ASHRAE15 or IRC).</p> <p>Do not mix air or gas other than R-32 in the refrigerant system. If air enters the refrigerant system, an excessively high pressure results, which may cause equipment damage or injury.</p> <p>For more information, consult "<a href="#">R-32 Guidelines</a>" on page 63.</p>	

 <b>WARNING</b>	
<p>When moving flammable A2L refrigerant to/from the unit from an auxiliary tank, a grounding strap must be used. An electrical charge builds when halocarbon refrigerant travels in a rubber hose. A grounding strap must be used between the auxiliary refrigerant tank and the unit's end sheet (earth ground), which will safely take the charge to the ground. A fire risk could occur if this procedure is not followed.</p>	

## Compliance Statements







Children should be supervised to ensure that they do not play with the appliance.

This appliance is not intended for use by persons (including children) with reduced physical, sensory, or mental capabilities, or lack of experience and knowledge, unless they have been given supervision or instruction concerning use of the appliance by a person responsible for their safety.

<b>NOTICE</b>
<p>Unit/equipment must be installed in a location that is not accessible to the general public.</p>

## Unit Labels

Pictogram warning and informational labels may be present on the unit. Consult the table below for reference.

Label	Description
	<p>Refrigerant class per ISO 817</p> <p><b>WARNING - flammable refrigerant present</b></p>
	<p>Read the technical manual for service instructions</p>
	<p>WARNING - A2L low-burning velocity refrigerant present</p>
	<p>Pressurized medium present</p>
	<p>Ultraviolet (UV) radiation present</p>
	<p>Read the technical manual for instructions</p>
	<p>WARNING - flammable refrigerant present</p>

# Electrical Installation

## Field Power Wiring

Wiring must comply with all applicable codes and ordinances. The warranty is voided if wiring is not in accordance with these specifications.

According to the National Electrical Code, a disconnecting means shall be located within sight of and readily accessible from the air conditioning equipment. The unit can be ordered with an optional factory mounted disconnect switch. This switch is not fused. Power leads must be over-current protected at the point of distribution. The maximum rated overcurrent protection device (MOP) value appears on the unit nameplate.

### CAUTION

All penetrations made through control panel knockouts must be sealed to prevent leaks. Gaps around field conductors and wiring should be sealed using elastic compound. Failure to do so may result in property damage.

## All Units

### WARNING

**Hazardous voltage. Can cause severe injury or death.**  
Disconnect electric power before servicing equipment. More than one disconnect may be required to de-energize the unit.

### CAUTION

Provide proper line voltage and phase balance. Improper line voltage or excessive phase imbalance constitutes product abuse. It can cause severe damage to the unit's electrical components.

All units are provided with internal power wiring for single point power connection. The power block or an optional disconnect switch is located within the main control panel. Field power leads are brought into the unit through knockouts in the bottom of the main control panel (see [Figure 1](#) and also [Table 2](#)). Refer to the unit nameplate to determine the number of power connections.

**NOTE:** To wire entry points, refer to certified drawings for dimensions.

The preferred entrance for power cables is through the bottom knockouts provided on the unit. If a side entrance is the only option, a hole may be drilled in the stationary upright.

The minimum circuit ampacity (MCA) is shown on the unit nameplate. Refer to [Table 2](#) for the recommended number of power wires.

Copper wire is required for all conductors. Size wires in accordance with the ampacity tables in Article 310 of the National Electrical Code. If long wires are required, it may be necessary to increase the wire size to prevent excessive voltage drop. Wires should be sized for a maximum of 3% voltage drop. Supply voltage must not vary by more than 10% of nameplate. Phase voltage imbalance must not exceed 2%. (Calculate the average voltage of the three legs. The leg with voltage deviating the farthest from the average value must not be more than 2% away.) Contact the local power company for correction of improper voltage or phase imbalance.

A ground lug is provided in the control panel. Size the grounding conductor in accordance with Table 250-95 of the [National Electrical Code](#).

In compliance with the [National Electrical Code](#), a 115 V factory mounted service receptacle outlet is provided. This outlet must be powered by a field connected 15 A, 115 V power supply. Leads are brought into the unit through a 7/8" knockout in the bottom of the main control panel.

**Table 2: Recommended Minimum Field Power Wiring**

Ampacity (MCA)	No. of Power Wires per Phase	Wire Gauge	Insulation Temperature Rating (°C)
20	1	14	75
25	1	12	75
35	1	10	75
50	1	8	75
65	1	6	75
85	1	4	75
100	1	3	75
115	1	2	75
130	1	1	75
150	1	1/0	75
175	1	2/0	75
200	1	3/0	75
230	1	4/0	75
255	1	250	75
300	2	1/0	75
350	2	2/0	75
400	2	3/0	75
460	2	4/0	75
510	2	250	75
600	3	3/0	75
690	3	4/0	75
765	3	250	75

**NOTE 1:** All wire sizes assume separate conduit for each set of parallel conductors.

**NOTE 2:** All wire sizes based on NEC Table 310.15 for 75°C THW wire (copper). Canadian electrical code wire ampacities may vary.

**NOTE 3:** All wire sizes assume no voltage drop for short power leads.

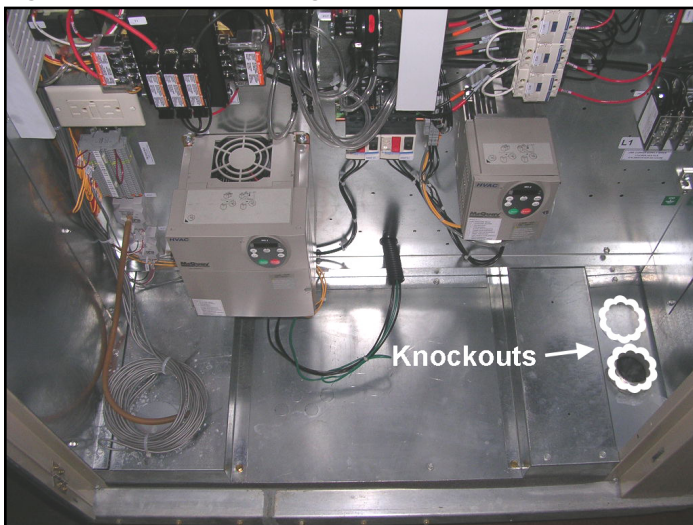
**Figure 1: MPS Power Wiring Knockout Locations**

## Field Control Wiring

### WARNING

**Electrical shock hazard. Can cause severe injury or death.**  
Connect only low voltage NEC Class II circuits to terminal block TB2.

The Maverick rooftop units are available with the following field control connections:

- Space sensor.
- Space sensor with setpoint adjustment.
- Fan operation output.
- VAV box output.
- Remote alarm output.
- External discharge air temperature reset.
- Outdoor air damper minimum position adjustment.

Descriptions of these field connections are included in the MicroTech Unit Controller manual.

# Mechanical Installation

## Installer Responsibilities

**CAUTION**  
 Sharp edges on sheet metal and fasteners can cause personal injury. This equipment must be installed, operated, and serviced only by an experienced installation company and fully trained personnel.

**WARNING**  
 Warning indicates potentially hazardous situations for PVC (Polyvinyl Chloride) and CPVC (Chlorinated Polyvinyl Chloride) piping in chilled water systems. In the event the pipe is exposed to POE (Polyolester) oil used in the refrigerant system, the pipe can be chemically damaged and pipe failure can occur.

The installation of this equipment shall be in accordance with the regulations of authorities having jurisdiction and all applicable codes. It is the responsibility of the installer to determine and follow the applicable codes.

## Service Clearance

Allow service clearances as approximately indicated in Figure 2. Also, Daikin Applied recommends providing a roof walkway to the rooftop unit as well as along each side of the unit that provides access to most controls and serviceable components.

Figure 2: Service Clearances

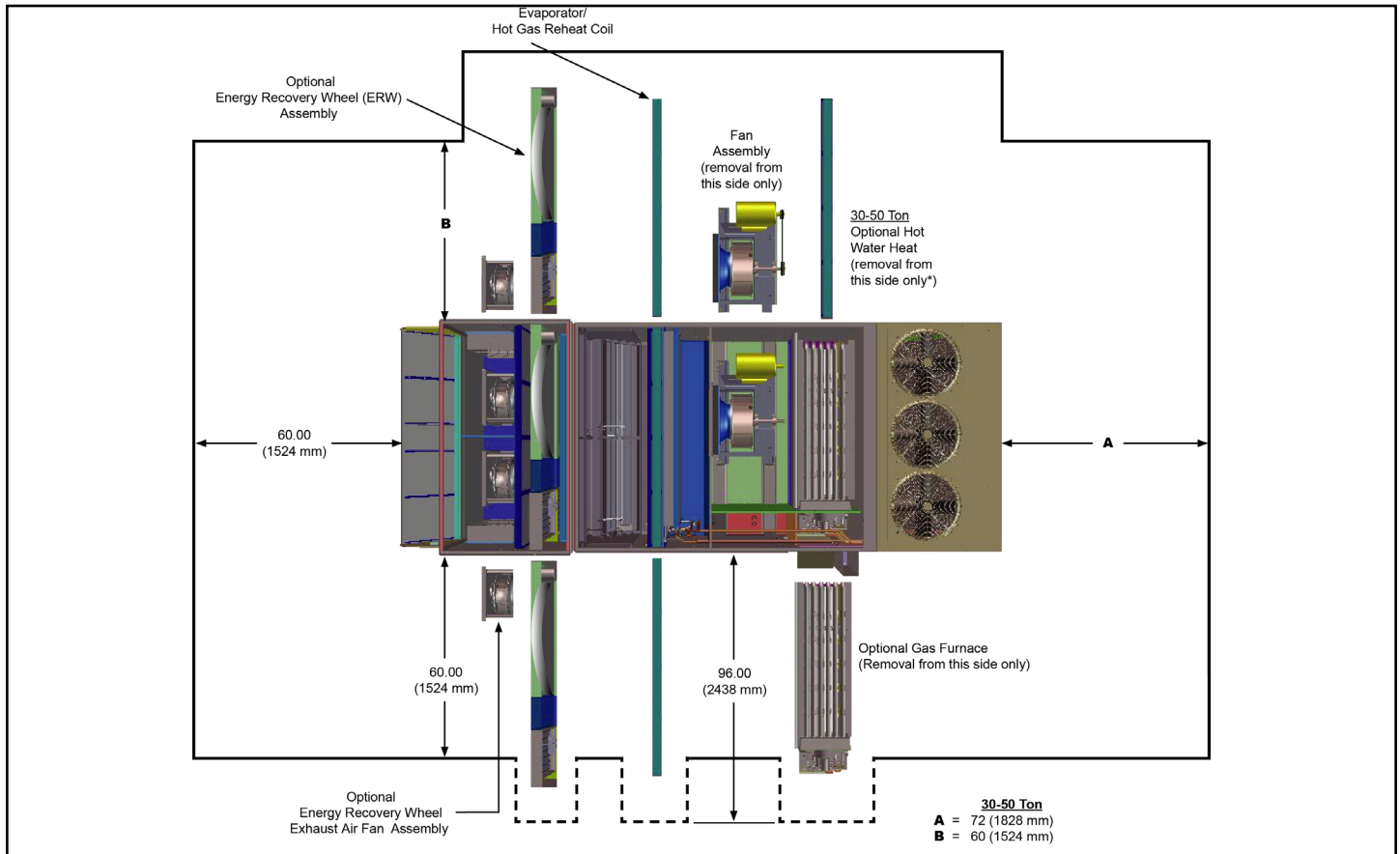

## Receiving and Handling

Carefully check equipment against the bill of lading to ensure all items have been received. Before unloading any unit, check the nameplate to make sure the voltage complies with the power supply available.

Inspect all units for damage upon arrival. If a unit has become dirty during shipment, carefully clean it prior to completing the inspection. Daikin Applied is not responsible for physical damage after the unit leaves the factory unless the contract with Daikin Applied states otherwise.

**NOTICE**  
 All units should be carefully inspected for damage when received. Report all loss or shipping damage using a claim form supplied by Daikin Applied.  
**VISIBLE LOSS OR DAMAGE:** Any external evidence of loss or damage must be noted on the freight bill or carrier's receipt, and signed by the carrier's agent. Failure to adequately describe such external evidence of loss or damage may result in the carrier's refusal to honor a damage claim.  
**CONCEALED LOSS OR DAMAGE:** Concealed loss or damage means loss or damage which does not become apparent until the unit has been unpacked or unwrapped. The contents may be damaged in transit due to rough handling even though the exterior may not show damages. When the damage is discovered, make a written request for inspection by the carrier's agent within **five (5) days** of the delivery date and file a claim with the form provided by Daikin Applied. Refer to the Daikin Applied Freight Policy for further information.

## Ventilation Clearance

Below are minimum ventilation clearance recommendations. The system designer must consider each application and provide adequate ventilation. If this is not done, the unit may not perform properly.

### *Unit(s) Surrounded by a Screen or a Fence:*

1. The bottom of the screen or fence should be at least 1 ft. (305 mm) above the roof surface.
2. The distance between the unit and a screen or fence should be as described in [Figure 2](#).
3. The distance between any two units within a screen or fence should be at least 120" (3048 mm).

### *Unit(s) Surrounded by Solid Walls:*

1. If there are walls on one or two adjacent sides of the unit, the walls may be any height. If there are walls on more than two adjacent sides of the unit, the walls should not be higher than the unit.
2. The distance between the unit and the wall should be at least 96" (2438 mm) on all sides of the unit.
3. The distance between any two units within the walls should be at least 120" (3048 mm).

Do not locate outside air intakes near sources of contaminated air.

If the unit is installed where windy conditions are common, install wind screens around the unit, maintaining the clearances specified (see [Figure 2](#)). This is particularly important to maintain adequate head pressure control when mechanical cooling is required at low outdoor air temperatures.

**NOTE:** Low head pressure may lead to poor and erratic refrigerant feed control at the thermostatic expansion valve. The unit has automatic control of the condenser fans which should provide adequate head pressure control down to 20°F (-6.7°C) provided the unit is not exposed to windy conditions. The system designer is responsible for assuring the condensing section is not exposed to excessive wind or air recirculation.

## Overhead Clearance

1. Unit(s) surrounded by screens or solid walls must have no overhead obstructions over any part of the unit.
2. The area above the condenser must be unobstructed in all installations to allow vertical air discharge.
3. The following restrictions must be observed for overhead obstructions above the air handler section:
  - a. There must be no overhead obstructions above the furnace flue, or within 9" (229 mm) of the flue box.
  - b. Overhead obstructions must be no less than 96" (2438 mm) above the top of the unit.
  - c. There must be no overhead obstructions in the areas above the outside air and exhaust dampers that are farther than 24" (610 mm) from the side of the unit.

## Roof Curb Assembly and Installation

### **WARNING**

Mold can cause personal injury. Some materials such as gypsum wall board can promote mold growth when damp. Such materials must be protected from moisture that can enter units during maintenance or normal operation.

Locate the roof curb and unit on a portion of the roof that can support the weight of the unit. The unit must be supported to prevent bending or twisting of the machine.

If building construction allows sound and vibration into the occupied space, locate the unit over a non-critical area. It is the responsibility of the system designer to make adequate provisions for noise and vibration in the occupied space.

Install the curb and unit level to allow the condensate drain to flow properly and allow service access doors to open and close without binding.

The gasketed top surface of the curb seals against the unit when it is set on the curb. These flanges must not support the total weight of the duct work. See "[Installing Ductwork](#)" on [page 17](#) for details on duct connections. It is critical that the condensate drain side of the unit be no higher than the opposite side.

## Assembly Instructions

Assembly of a typical roof curb is shown in [Figure 3](#).

1. Set curbing parts A thru G per dimensions shown over roof opening or on a level surface. Note location of supply air opening. Check alignment of all mating screw holes.
2. Screw curbing parts together using fasteners provided. Leave all screws loose until curb is checked to be square.
3. Square entire curbing assembly and securely tighten all screws.
4. Position curb assembly over roof openings. Curb must be level within 0.25 inches from side to side and 1.50 inches over its length. Check that top surface of curb is flat with no bowing or sagging.
5. Weld curb assembly in place. Caulk all seams watertight. Remove backing from 0.25 × 1.50 wide gasket and apply to surfaces shown by crosshatching.
6. Check that electrical connections are coordinated.

**Figure 3: Roof Curb Assembly (MPS 030 – 035 Example)**

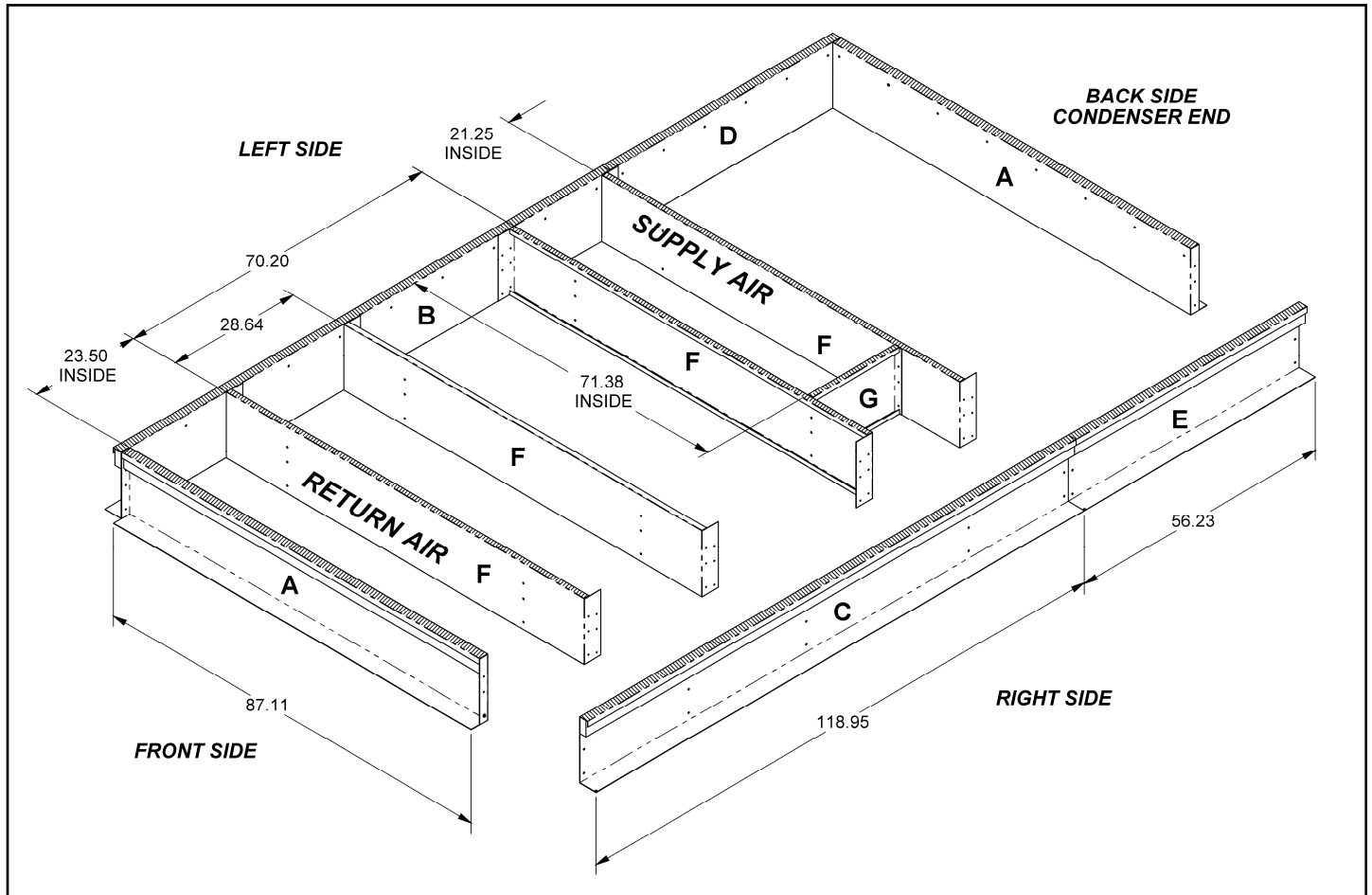
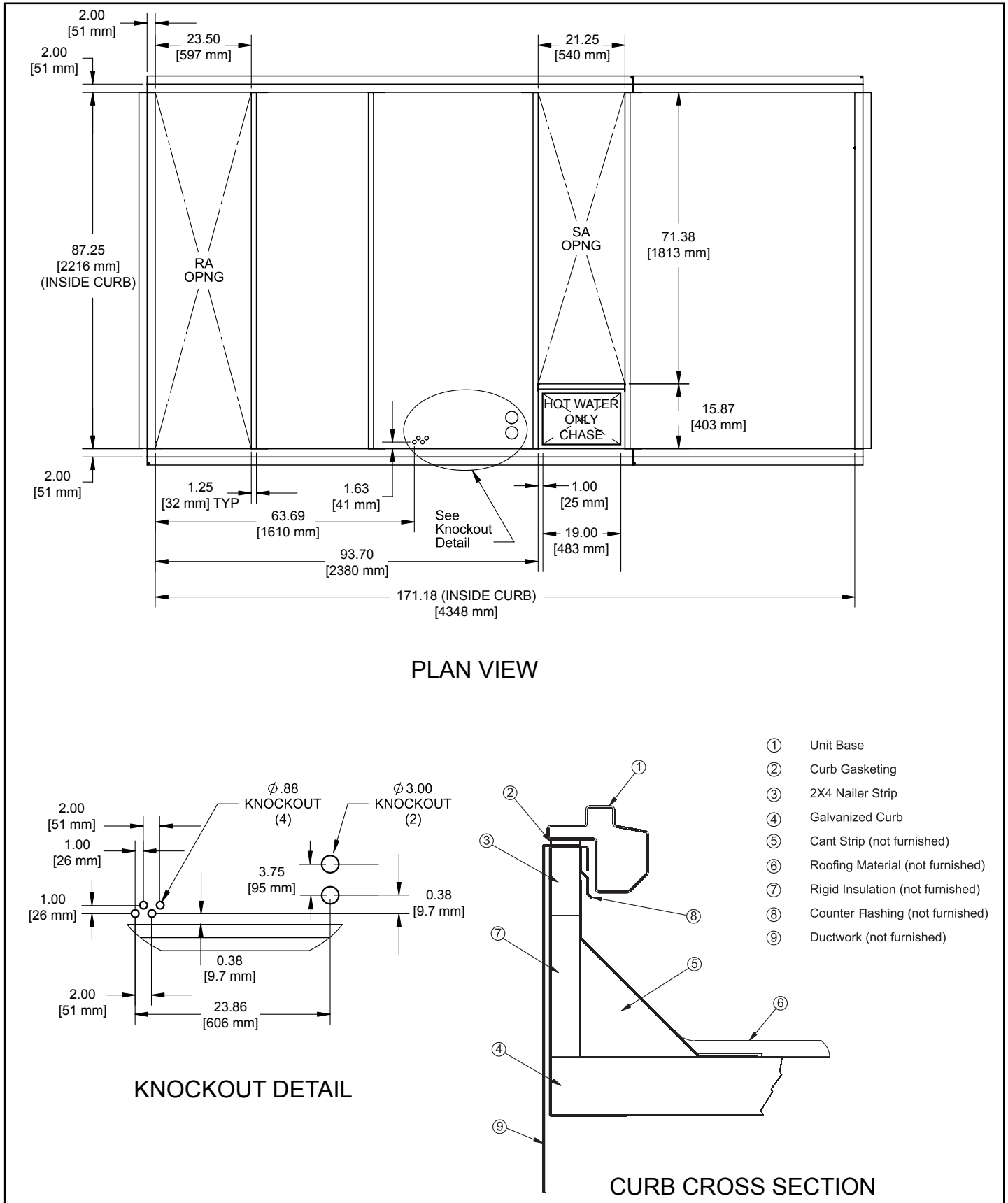

Figure 4: Roof Curb Layout—MPS 030 – 035



- ① Unit Base
- ② Curb Gasketing
- ③ 2X4 Nailer Strip
- ④ Galvanized Curb
- ⑤ Cant Strip (not furnished)
- ⑥ Roofing Material (not furnished)
- ⑦ Rigid Insulation (not furnished)
- ⑧ Counter Flashing (not furnished)
- ⑨ Ductwork (not furnished)

Figure 5: Roof Curb Layout—MPS 040 – 050

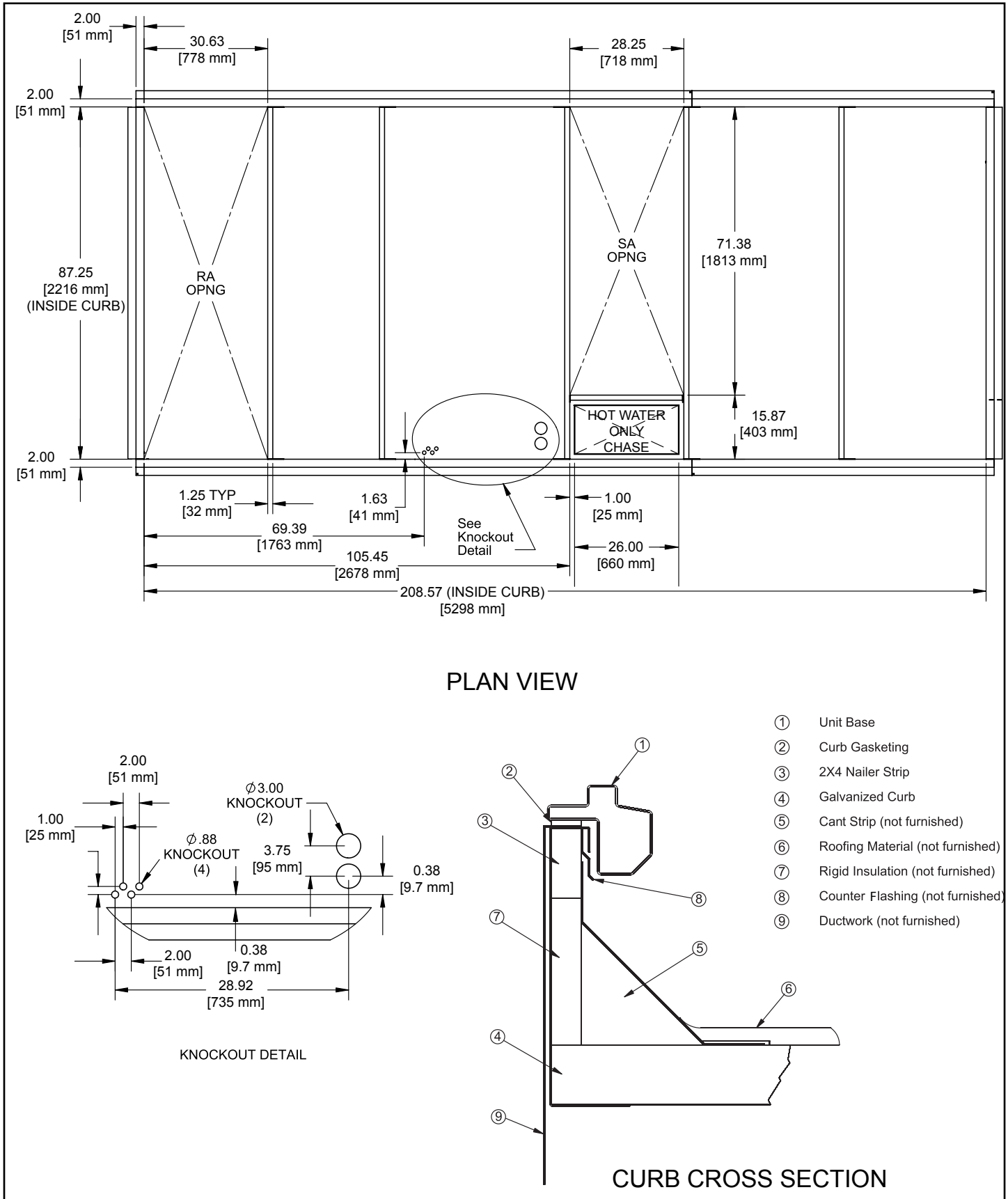

Figure 6: MPS 030–035 Roof Curb with Energy Recovery Wheel

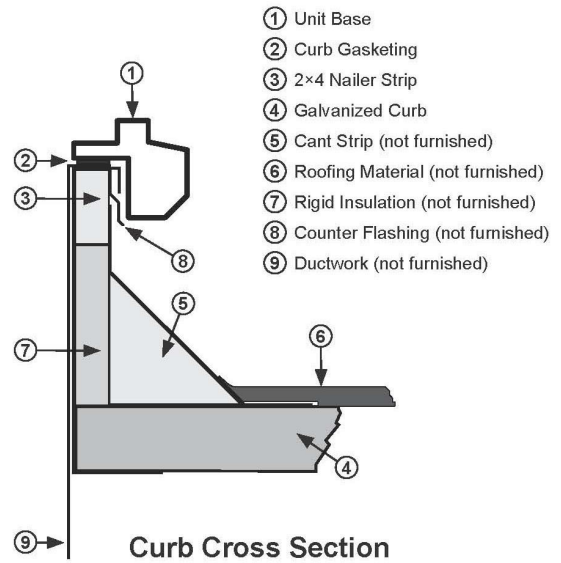
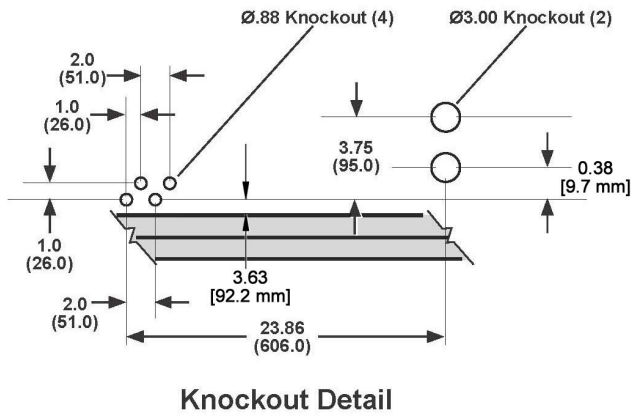
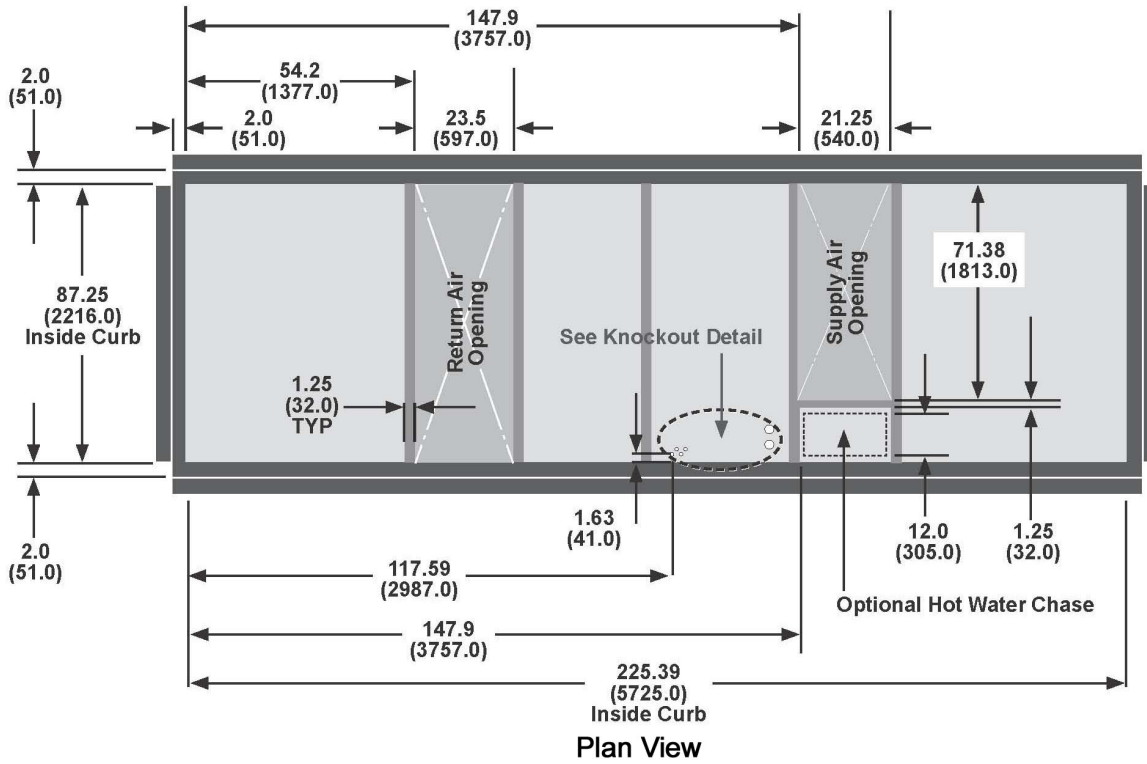
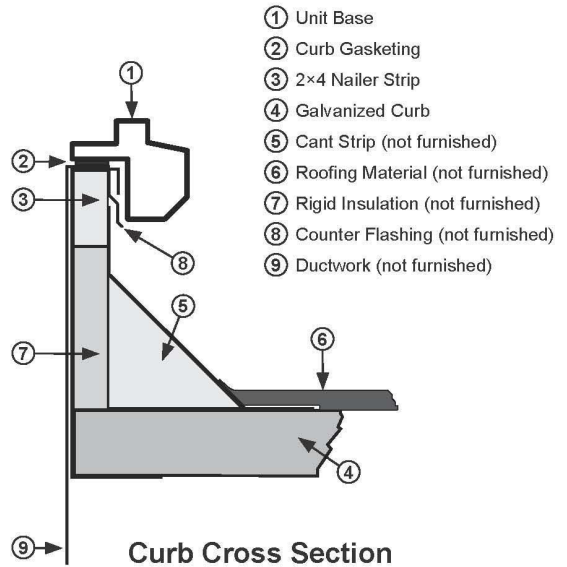
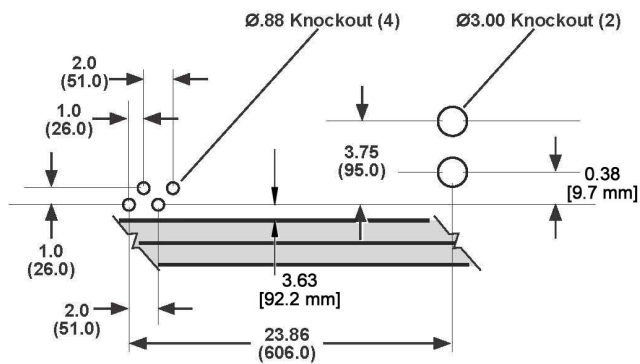
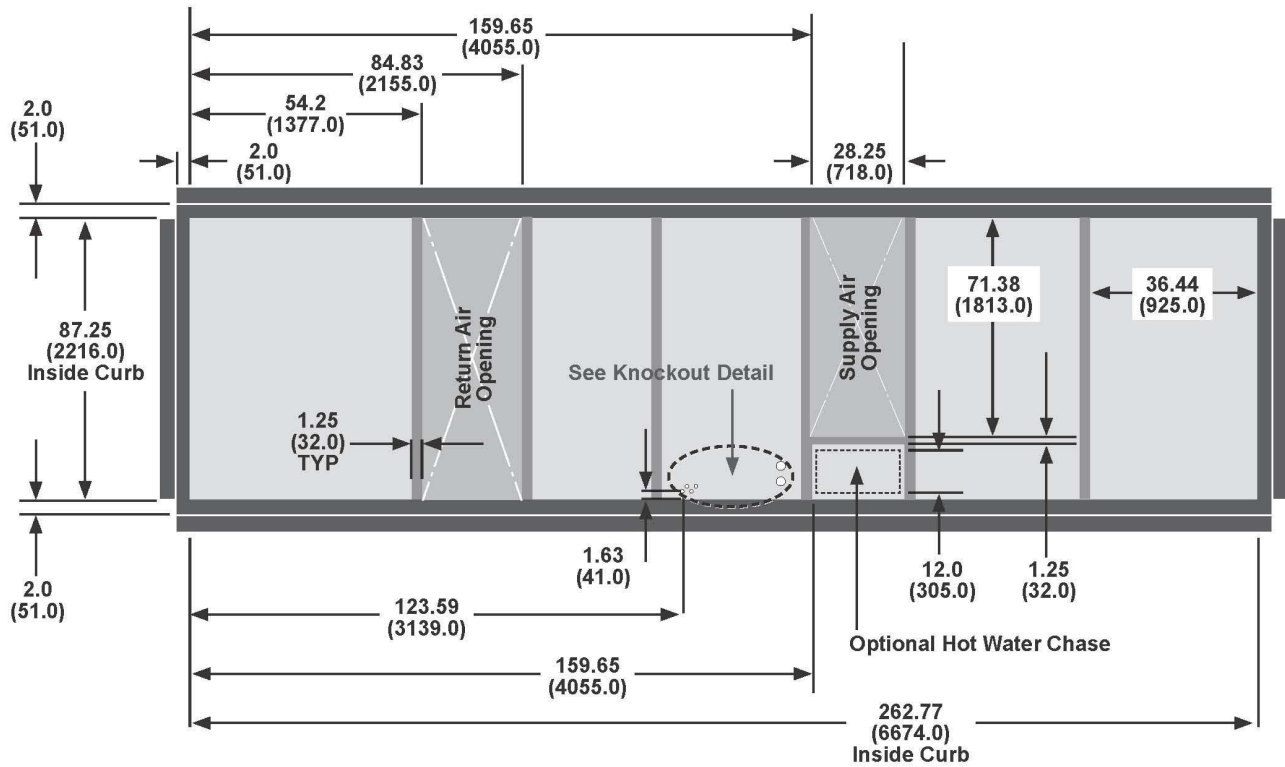

Figure 7: MPS 040-050 Roof Curb with Energy Recovery Wheel



## Lifting Guidance

Daikin Applied equipment is designed to withstand the loads of the lifting and rigging process resulting from ASME Standard P30.1 - Planning for Load Handling Activities or equivalent. Lifting guidance is intended for installations of newly delivered equipment. If moving previously installed equipment for re-location or disposal, consideration should be given to unit condition. Equipment should also be drained as unit weight and center of gravity values do not reflect the addition of water for lifting.

**⚠ DANGER**

Improper rigging, lifting, or moving of a unit can result in unit damage, property damage, severe personal injury, or death. See the as-designed, certified dimensioned drawings included in the job submittal for the weights and center of gravity of the unit. If the drawings are not available, consult the local Daikin Applied sales office for assistance.

Installation is to be performed only by qualified personnel who are familiar with local codes and regulations, and experienced with this type of equipment. Lifting equipment and mechanisms must be determined by the Lifting Director per the current version of ASME Standard P30.1 or equivalent and must be suited for the load capacity. Daikin Applied is not a licensed nor certified rigging specialist. Therefore it is the customer's responsibility to consult a certified rigging contractor to rig, lift, and move components and subcomponents properly and safely as needed.

**⚠ CAUTION**

Forklifts may not be used to lift or move Maverick units as the method may result in unit damage.

**⚠ CAUTION**

When around sharp edges, wear appropriate Personal Protective Equipment (PPE), such as gloves, protective clothing, foot wear, eye protection, etc., to prevent personal injury.

### Lifting Brackets

Lifting bracket or hole designs vary from product to product. Rules of engagement with the lifting point are the same regardless of the attachment type. For Maverick units, a typical lifting bracket with 2" (51 mm) diameter holes is found on the sides of the unit base. See the as-designed certified drawings for specific lifting points on this product model.

Engagement with each bracket is to be as close to vertical as possible. The maximum allowable lift angle from the vertical is 30 degrees as shown in Figure 8. If the lift angle shifts beyond 30 degrees from vertical on any of the lift points, the lift shall not proceed until a plan and rigging can be secured that will correct the angle of lift.

**⚠ WARNING**

The lifting angle must not go beyond 30 degrees from vertical or the unit can become unstable which may result in unit damage, property damage, severe personal injury, or death.

Figure 8: Illustration of Lifting Bracket Holes

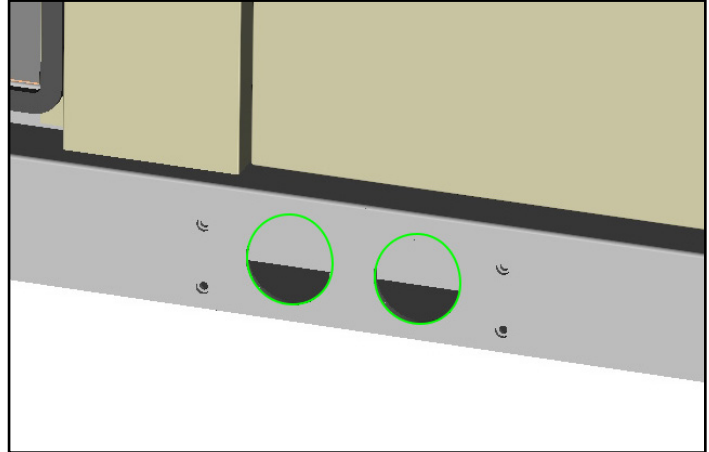

Figure 9: Illustration of Allowed Angle Label

**⚠ WARNING**

**All factory provided lifting points must be used. Unit must remain level during lift and transit!**

The lifting and tie-down angle must not go beyond 30 degrees from vertical or the unit can become unstable which may result in unit damage, property damage or severe personal injury or death.

 A diagram showing a red circle representing the unit's base. Two dashed vertical lines represent the vertical axis. Two arrows labeled 'Lifting Straps +/- 30°' point upwards and outwards from the top of the circle. Two arrows labeled 'Tie-Down +/- 30°' point downwards and outwards from the bottom of the circle.

### Lifting Equipment

Lifting equipment is supplied by the user or their designate. This is typically selected around the unit certified information of the equipment to be lifted and the available lifting equipment planned to be at the site where the lift is to take place. It is the responsibility of the Lifting Director to follow a standard practice of lift planning and equipment selection, like that found in the ASME P30 series of standards. Lifting plan and equipment must ensure that the only contact with the unit is at that lifting brackets. Straps, chains or spreader bars that are likely to be used shall not come in contact with the unit.

**⚠ CAUTION**

Lifting mechanisms must not make contact with the unit beyond the lifting bracket. Extreme care must be used when rigging the unit to prevent damage to the control panels, unit handles, unit piping, and unit frame.

## Lifting Points

Lifting points are predetermined by design. When lifting, all factory installed lifting brackets must be used. Unit must remain level throughout the entire lifting event. Level is defined as one end being no more than 0.25" per foot of unit length to the opposite end.

### WARNING

Be aware that the center of gravity may not necessarily be in the geometric center of the unit. No additional items can be added to a lift with the unit as it may affect the center of gravity and cause unit damage, property damage, severe personal injury, or death. Refer to as-designed, certified drawings for weight, center of gravity location and details specific to unit configuration.

Figure 10: Typical Lifting Points Locations (MPS 040–050)

### 8 Lifting Points

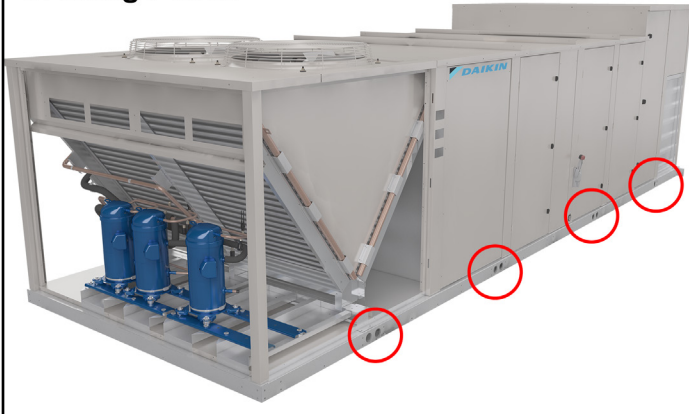
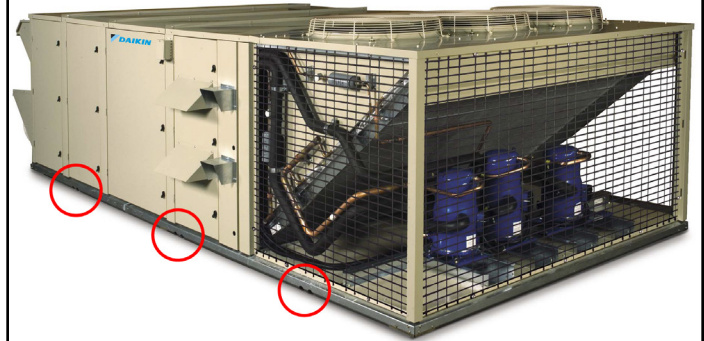

Figure 11: Typical Lifting Points Locations (MPS 030–035)

### 6 Lifting Points



## Transit

When the unit is being tied down for transit, the maximum allowable attachment angle from the vertical is 30 degrees in the opposite direction of lifting in Figure 8. Shimming of the unit under the lifting brackets or tie-down points must be used to ensure even contact along the length of the base rail.

## Condensate Drain Pipe Connection

**WARNING**

Warning indicates potentially hazardous situations for PVC (Polyvinyl Chloride) and CPVC (Chlorinated Polyvinyl Chloride) piping in chilled water systems. In the event the pipe is exposed to POE (Polyolester) oil used in the refrigerant system, the pipe can be chemically damaged and pipe failure can occur.

**WARNING**

Drain pans must be cleaned periodically. Material in uncleaned drain pans can cause disease. Cleaning should be performed by qualified personnel.

The unit is provided with a 1" male NPT condensate drain connection. For proper drainage, level the unit and drain pan side to side and install a P-trap.

Figure 12 shows the layout of the condensate drain connection. The distance from the drain pan outlet to the horizontal run of the P-trap should be a distance of twice the static pressure in the drain pan.

**NOTE:** Do not use PVC or CPVC for P-trap.

**Example:** If the static pressure as measured in the drain pan is 1.5", then the distance between the drain outlet and the horizontal run should be 3".

Draining condensate directly onto the roof may be acceptable; refer to local codes. Provide a small drip pad of stone, mortar, wood, or metal to protect the roof against possible damage.

If condensate is piped into the building drainage system, pitch the drain line away from the unit a minimum of 1/8" per foot. The drain line must penetrate the roof external to the unit. Refer to local codes for additional requirements. Sealed drain lines require venting to provide proper condensate flow.

Where the cooling coils have intermediate condensate pans on the face of the evaporator coil, copper tubes near both ends of the coil supply drainage to the main drain pan. Verify the tubes are in place and open before putting the unit into operation.

Periodically clean to prevent microbial growth/algae buildup from plugging the drain and causing the drain pan to overflow. Clean drain pans to prevent the spread of disease. Cleaning should be performed by qualified personnel.

Figure 12: Condensate Drain Connection

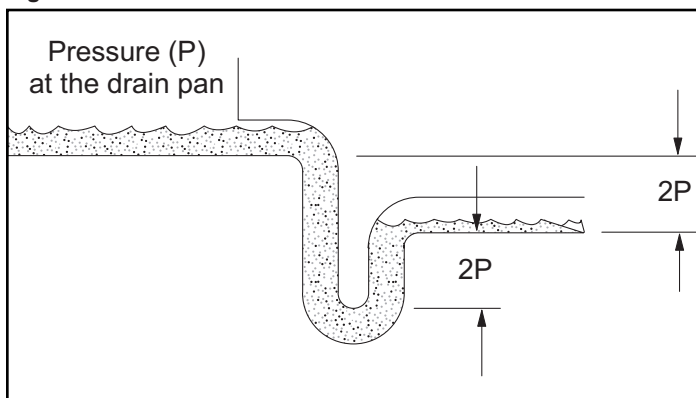

## Damper Assemblies

The optional damper assemblies described in this section are ordered with factory-installed actuators and linkages. The following sections describe the operation and linkage adjustment of the factory option.

Figure 13: Damper Assembly

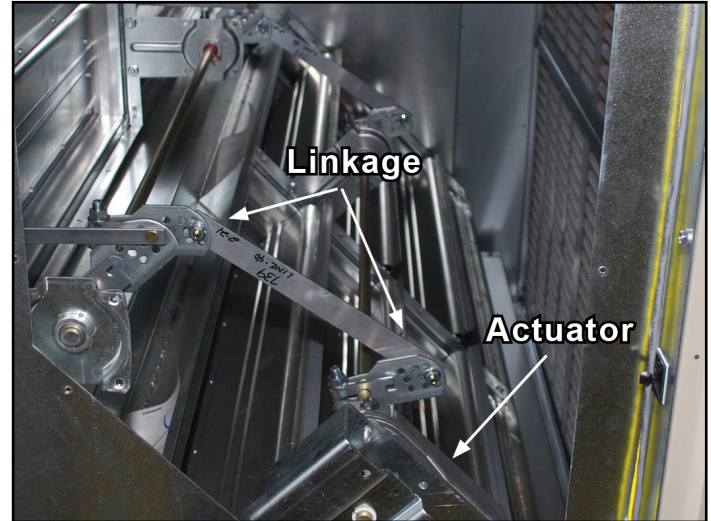

## Economizer Dampers

As the single actuator modulates, the outside air dampers open, the return air dampers close, and the exhaust air exits the unit through the gravity relief dampers.

The economizer comes with manually adjustable linkage (Figure 13). The damper is set so that the crankarm moves through a 90-degree angle to bring the economizer dampers from full open to full close. Mechanical stops are placed in the crankarm mounting bracket. Do not remove stops. Driving the crankarm past the stops results in damage to the linkage or damper.

## Outdoor Air Dampers (0% to 30%)

These dampers are intended to remain at a fixed position during unit operation, providing fresh air quantities from 0 to 30% of the total system airflow, depending on the damper setting.

The damper position may be set at the unit controller keypad (refer to the unit controller manual for further detail). During unit operation, the damper is driven to the position set at the unit controller. During the off cycle, the damper is automatically closed.

## Cabinet Weather Protection

### CAUTION

**Transportation, rigging, or maintenance can damage the unit's weather seal.** Periodically inspect the unit for leakage. Standing moisture can promote microbial growth, disease, or damage to the equipment and building

This unit ships from the factory with fully gasketed access doors and cabinet caulking to provide weather resistant operation. After the unit is set in place, inspect all door gaskets for shipping damage and replace if necessary. Protect the unit from overhead runoff from overhangs or other such structures.

## Installing Ductwork

### WARNING

**Mold can cause personal injury.** Materials such as gypsum wall board can promote mold growth when damp. Such materials must be protected from moisture that can enter units during maintenance or normal operation.

On vertical-supply/vertical-return units, if a Daikin Applied roof curb is not used, the installing contractor should make an airtight connection by attaching field fabricated duct collars to the bottom surface of the unit's duct opening. Do not support the total weight of the duct work from the unit. See roof curb layouts as shown in "Roof Curb Assembly and Installation" on page 8.

**Table 3: Rated Airflow**

Unit Size (tons)	AHRI Rated Airflow
030	7500
035	8750
040	10000
050	12500

Use flexible connections between the unit and ductwork to avoid transmission of vibration from the unit to the structure.

To minimize losses and sound transmission, design duct work per ASHRAE and SMACNA recommendations.

Where return air ducts are not required, connect a sound absorbing T or L section to the unit return to reduce noise transmission to the occupied space.

Ductwork exposed to outdoor conditions must be built in accordance with ASHRAE and SMACNA recommendations and local building codes.

## Installing Duct Static Pressure Sensor Taps

For all VAV units, duct static pressure taps must be field installed and connected to the static pressure sensor 1 (SPS1) in the unit. Sensor SPS1 is standard on VAV units and is located in the main control panel.

Carefully locate and install the duct static pressure sensing tap. Improperly locating or installing the sensing tap causes unsatisfactory operation of the entire variable air volume system. Below are pressure tap location and installation recommendations. The installation must comply with local code requirements.

1. Install a tee fitting with a leak-tight removable cap in each tube near the sensor fitting. This facilitates connecting a manometer or pressure gauge if testing is required.
2. Use different colored tubing for the duct pressure (HI) and reference pressure (LO) taps, or tag the tubes. Daikin Applied recommends 3/16" ID tubing.
3. Locate the duct pressure (HI) tap near the end of a long duct to ensure that all terminal box take-offs along the run have adequate static pressure.
4. Locate the duct tap in a nonturbulent flow area of the duct. Keep it several duct diameters away from take-off points, bends, neckdowns, attenuators, vanes, or other irregularities.
5. Use a static pressure tip (Dwyer A302 or equivalent) or the bare end of the plastic tubing for the duct tap. (If the duct is lined inside, use a static pressure tip device.)
6. Install the duct tap so that it senses only static pressure (not velocity pressure). If a bare tube end is used, it must be smooth, square (not cut at an angle) and perpendicular to the airstream (see [Figure 15](#)).
7. Locate the reference pressure (LO) tap near the duct pressure tap within the building. If the tap is not connected to the sensor, unsatisfactory operation will result.
8. Route the tubes through the curb and feed them into the unit through the knockout in the bottom of the control panel (see [Figure 14](#)). Connect the tubes to appropriate barbed fittings (on SPS1) in the control panel. (Fittings are sized to accept 3/16" ID tubing.)

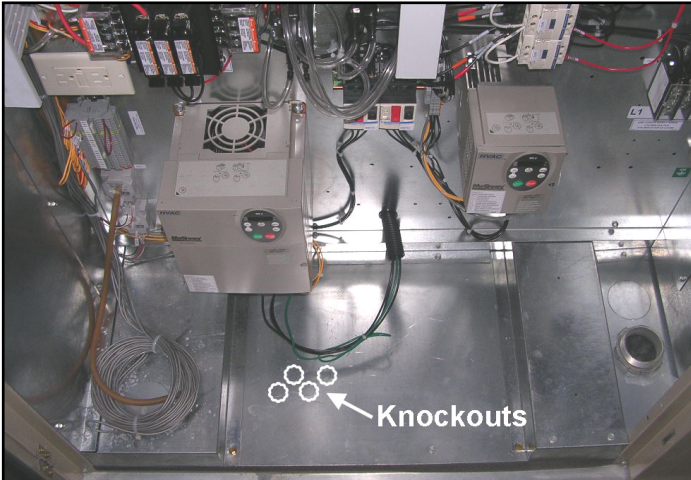
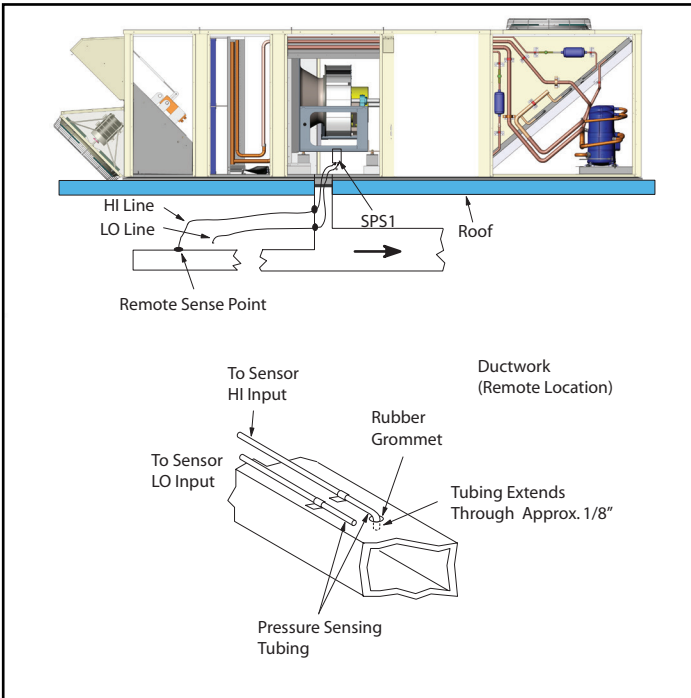
**Figure 14: Static Pressure Tubing Knockout Location****Figure 15: Duct Static Pressure Sensing Tubing Installation**

## Installing Building Static Pressure Sensor Taps

### ⚠ CAUTION

Fragile sensor fittings. If you must remove tubing from a pressure sensor fitting, use care. Do not use excessive force or wrench the tubing back and forth to remove or the fitting can break off and damage sensor.

If a unit has building static pressure control capability, you must field install and connect static pressure taps to the static pressure sensor SPS2 in the unit. This sensor is located at the bottom of the main control panel next to SPS1.

Carefully locate and install the two static pressure sensing taps. Improper location or installation of the sensor taps causes unsatisfactory operation. Below are pressure tap location and installation recommendations for both building envelope and lab, or "space within a space" pressure control applications. The installation must comply with local code requirements.

### Building Pressurization Applications

1. Install a tee fitting with a leak-tight removable cap in each tube near the sensor fitting. This facilitates connecting a manometer or pressure gauge if testing is required.
2. Locate the building pressure (high) tap in the area that requires the closest control. Typically, this is a ground level floor that has doors to the outside.
3. Locate the building tap so it is not influenced by any source of moving air (velocity pressure). These sources may include air diffusers or outside doors.
4. Route the building tap tube through the curb and feed it into the unit through the knockout in the bottom of the control panel (refer to [Figure 14](#)). Connect the 3/16" ID tube to the (high) fitting for sensor SPS2.
5. Locate the reference pressure (low) tap on the roof. Keep it away from the condenser fans, walls, or anything else that may cause air turbulence. Mount it high enough above the roof so it is not affected by snow. Not connecting the reference tap to the sensor results in unsatisfactory operation.
6. Use an outdoor static pressure tip (Dwyer A306 or equivalent) to minimize the adverse effects of wind. Place some type of screen over the sensor to keep out insects. Loosely packed cotton works well.
7. Route the outdoor tap tube out of the main control panel through a small field-cut opening in the upright. Seal the penetration to prevent water from entering. Connect the 3/16" ID tube to the (low) fitting for sensor SPS2.

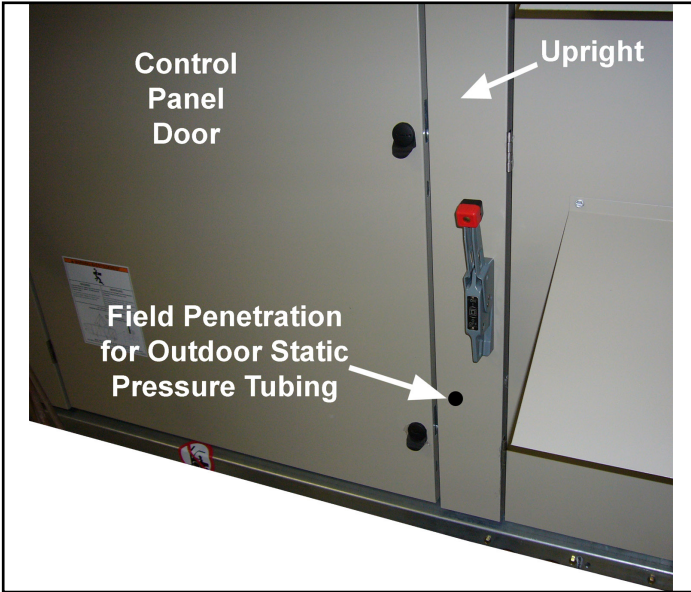
**Figure 16: Outdoor Static Pressure Tubing Installation****Lab Pressurization Applications**

1. Install a "T" fitting with a leak-tight removable cap in each tube near the sensor fitting. This facilitates connecting a manometer or pressure gauge if testing is required.
2. Use different colored tubing for the controlled space pressure (high) and reference pressure (low) taps, or tag the tubes.
3. Regardless whether the controlled space is positive or negative with respect to its reference, locate the high pressure tap in the controlled space (the setpoint can be set between -0.2" and 0.2" WC).
4. Locate the reference pressure (low) tap in the area surrounding the controlled space. Not locating the reference tap to the sensor results in unsatisfactory operation.
5. Locate both taps so they are not influenced by any source of moving air (velocity pressure). These sources may include air diffusers or doors between the high and low pressure areas.
6. Route the building tap tube between the curb and the supply duct and feed it into the unit through the knockout in the bottom of the control panel.
7. Connect the tube to the (high) fitting for sensor SPS2.

**Spring Isolated Fans****⚠ WARNING**

Moving machinery hazard. Can cause severe injury or death. Before servicing equipment, disconnect power and lockoff. More than one disconnect may be required to de-energize unit. Prior to operating the fans for the first time, refer to "Check, Test, and Start" on page 58.

**Releasing Spring Mounts**

The spring-mounted supply fan is locked down with four shipping bolts for shipment. Remove each shipping bolt before operating the fans. Figure 17 shows a typical spring mount with a height adjustment nut and a shipping bolt. After removing the shipping bolts, rock the fan assembly by hand to check for freedom of movement.

**Adjusting Spring Mounts**

During operation all fans should ride level. Level the fan assembly by performing the following:

1. Loosen the 3/8" cap screw (do not remove).
2. Loosen the spring cap nut.
3. Rotate the 5/8" adjustment nut counter-clockwise to raise the fan assembly, or clockwise to lower the fan assembly.
4. Tighten the 3/8" cap screw.
5. Tighten the spring cap nut.

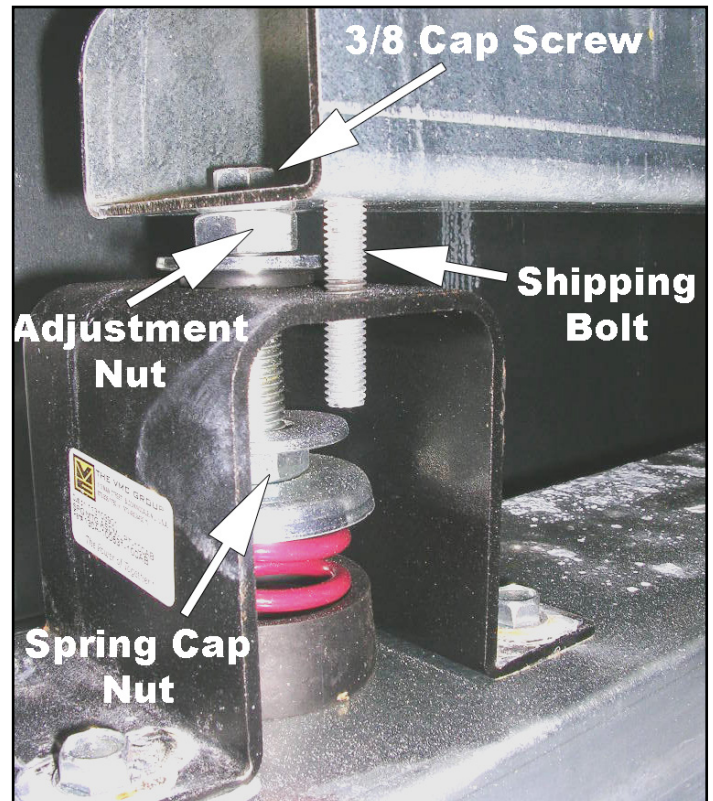
**Figure 17: Spring Mounts**

# Optional Electric Heat

## Electric Heater Design

If the 8th character in the model number is an “E”, the rooftop unit was furnished with a factory installed electric furnace (Example, MPS035JE). The Maverick commercial rooftop units are available with low, medium, or high heat output (see capacities in Table 4). This packaged electric heat rooftop unit is designed for outdoor non-residential installations only.

The electric heat design consists of a heating coil, DDC staging control, and all operational safeties. The safety switches include high-limit temperature switches and individual coil fusing.

The high limit switch is an automatic reset switch. It opens the control circuit and shuts the heater down when the temperature reaches 160°F. The high limit switch closes again allows the heater to run when the temperature gets to 130°F. There is a second level of protection with an auxiliary high limit switch. This switch opens up and shuts the heater down when the temperature reaches 250°F. The auxiliary switch automatically resets again at 210°F. The third level of protection is the secondary auxiliary high limit switch which shut the heater down at 285°F. This switch requires a manual reset.

Figure 18: Electric Heat Section

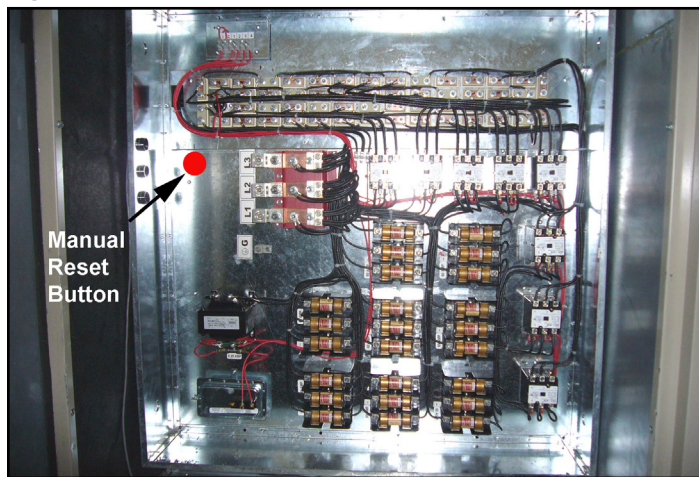

Table 4: MPS 030 – 050 Electric Heating Capacities

Tons	Nom cfm	Stages	Low				Medium				High			
			kW	Min cfm	MBh	Delta T*	kW	Min cfm	MBh	Delta T*	kW	Min cfm	MBh	Delta T*
30	12,000	4	54	2900	184	14.2	72	3800	246	19.0	90	4800	307	23.7
35	14,000	4	54	2900	184	12.2	72	3800	246	16.3	90	4800	307	20.3
40	16,000	4	72	3800	246	14.2	90	4800	307	17.8	108	5700	369	21.3
50	20,000	4	72	3800	246	11.4	90	4800	307	14.2	108	5700	369	17.1

\* Temperature rise is calculated at nominal cfm

Table 5: MPS 030 – 050 Electric Heat Data - Max Temp. 60°F (15.6°C)

kW	Voltage	Amps
54	208	150
	230	136
	460	68
	575	54
72	208	200
	230	181
	460	90
	575	72
90	208	250
	230	226
	460	113
	575	90
108	460	136
	575	108

# Optional Gas Heat

## Daikin Applied Tubular Heater Series Package Heater Module

### ANSI Z83.8/CSA 2.6

**DANGER**

**FIRE OR EXPLOSION HAZARD**

- Failure to follow safety warnings exactly could result in serious injury, death, or property damage.
- Be sure to read and understand the installation, operation and service instructions in this manual.
- Improper installation, adjustment alteration, service or maintenance can cause serious injury, death, or property damages.
- Do not store or use gasoline or other flammable vapors and liquids in the vicinity of this or any other appliance.
- **WHAT TO DO IF YOU SMELL GAS**
  - Do not try to light any appliance.
  - Do not touch any electrical switch; do not use any phone in your building.
  - Leave the building immediately.
  - Immediately call you gas supplier. Follow the gas supplier’s instructions.
  - If you cannot reach your gas supplier, call the fire department.
- Installation and service must be performed by a qualified installer, service agency or the gas supplier.

DAT heater series modules are a recognized furnace component is design certified by Intertek testing services (ETL) for outdoor installation and installation downstream from refrigeration systems in cabinet applications.

This furnace must be installed in the designated non-combustible heat chamber of the cabinet. If it is removed, it is only to be replaced with an approved Original Manufacture Equipment Supplier furnace(s), installed and operated as specified by the approved Original Manufacture Equipment Supplier. It is not designed to have any portion of the heat exchanger outside the cabinet in which the furnace module is housed.

The Rating Plate/Name Plate has been permanently attached to the furnace assembly. It contains information including gas type, maximum and minimum input rating, manifold pressure, maximum and minimum inlet gas pressure, maximum and minimum airflow requirements, output capacity and electrical rating for the furnace. The plate also includes model number, serial number and scan code. This plate is to always remain attached to the furnace.

This furnace must be applied in accordance with the requirements of its listing.

Hooded and screened openings for combustion air have been provided in the furnace(s) access door. The air opening provides unrestricted combustion air to the burners and sized such that a minimum free area is maintained. The minimum free area is defined as 1 in<sup>2</sup> (625 mm<sup>2</sup>) per 4000 BTUH (2.345 kW).

The access door provides direct access to the furnace vestibule where the burners, combustion inducer fan, ignition controls and ignition safeties are housed.

The vent discharge is sized such that it is equal to or larger than the discharge area of the combustion exhaust inducer fan.

A non-adjustable flame rollout switch will shut off the gas supply to the main burners should the switch reach a temperature of 250°F (121°C).

The cabinet supply air flow delivery package has been designed to provide sufficiently well distributed air flow across the heat exchanger to limit temperature rise as follows:

- 409 Stainless Steel: 1080°F (600°C)

Clearance from combustibles to be no less than as listed in [Table 6](#).

**Table 6: Clearances from Combustibles**

Module Surfaces	Clearance
Sides and Back	6 in (152mm)
Bottom	2 in (51mm)
Top	6 in (152mm)
Front	36 in (914mm)
Vent Pipe to any Combustible Surface	6 in (152mm)

Do not use this package heater if any part has been under water. Immediately call a qualified service technician to inspect the heater and any gas control which has been under water.

## Gas Furnace Design

If the 8th character in the model number is a “G”, the rooftop unit was furnished with a factory installed furnace (Example, MPS035JG). The Maverick commercial rooftop units are available with either the low heat input or the high heat input furnace (see capacities in Table 7). This packaged gas heat rooftop unit is designed for outdoor non-residential installations only.

The gas heat furnace design consists of a tubular heat exchanger, in-shot burner manifold with gas valve, induced combustion blower, gas heat DDC control module and all operational safeties. The tubular heat exchanger can come with the standard aluminized steel construction or the optional stainless steel construction. The safety switches include a high-limit temperature switch, an auxiliary high-limit switch, a combustion blower proof of airflow, and the flame roll-out switch.

The high limit switch is an automatic reset switch and it opens up at 160°F (71.1°C) to shut the furnace down and closes at 130°F (54.4°C). The auxiliary limit switch is a manual reset and opens up at 120°F (48.9°C) to shut the furnace down.

Figure 19: Gas Heat Section

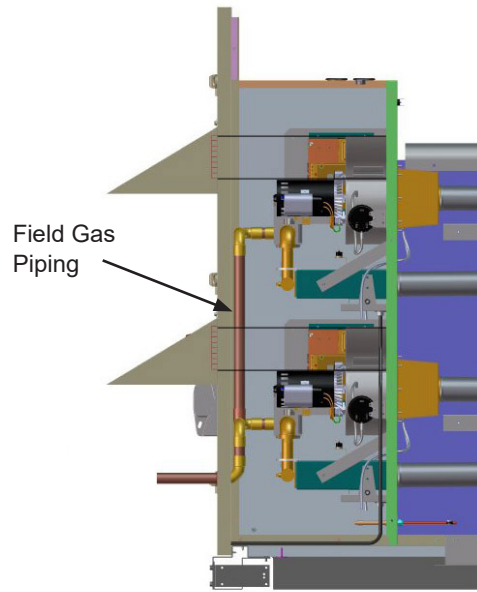

## Gas Heating Capacity Data

Table 7: MPS 030 - 050 Gas Heating Capacities

	030-035		040-050		040-050
	Low Heat	High Heat	Low Heat	Medium Heat	High Heat
Heating Input in MBh	300	600	300	600	800
Heating Output in MBh	243	486	243	486	648
Steady State Efficiency	81%	81%	81%	81%	81%
Number of Stages	2	4	2	4	3
Turndown <sup>1</sup>	4:1	8:1	4:1	8:1	10:1
Minimum Airflow <sup>2</sup>	3700	7400	4900	9800	13067
Maximum Temperature Rise	55°F (30.6°C)	95°F (52.8°C)	55°F (30.6°C)	95°F (52.8°C)	93°F (51.7°C)
<b>Gas Main Pressure</b>					
Natural Gas Staged Heat in WC	7-14	7-14	7-14	7-14	7-14
Natural Gas Modulating Heat in WC	10-14	10-14	10-14	10-14	10-14
Liquid Propane in WC	12-14	12-14	12-14	12-14	12-14
Connection Pipe (qty)	3/4" (1)	3/4" (2)	3/4" (1)	3/4" (2)	3/4" (2)
<b>Manifold Pressure — Natural Gas (per gas valve)</b>					
Stage 1 (WC)	1.2	1.2	1.2	1.2	1.1
Stage 2 (WC)	3.2	3.2	3.2	3.2	3.5
Modulating Low Fire	0.4	0.4	0.4	0.4	0.2
<b>Propane</b>					
Stage 1 (WC)	2.3	2.3	2.3	2.3	3.0
Stage 2 (WC)	10.0	10.0	10.0	10.0	10.0
Modulating Low Fire	N/A	N/A	N/A	N/A	0.6

<sup>1</sup>Modulating gas heat only.  
<sup>2</sup>Minimum airflow at full fire for 60°F (33.3°C) temperature rise.

## Warranty Exclusion

Warranty is void if the furnace is operated in the presence of chlorinated vapors, if the airflow through the furnace is not in accordance with rating plate, or if the wiring or controls have been modified or tampered with.

### WARNING

**Hot surface hazard. Can cause severe equipment damage, personal injury, or death.** Allow burner assembly to cool before servicing equipment.

### WARNING

**Units equipped with gas heating must not be operated in an atmosphere contaminated with chemicals which will corrode the unit such as halogenated hydrocarbons, chlorine, cleaning solvents, refrigerants, swimming pool exhaust, etc. Exposure to these compounds may cause severe damage to the gas furnace and result in improper or dangerous operation.** Operation of the gas furnace in such a contaminated atmosphere constitutes product abuse and will void all warranty coverage by the manufacturer. Questions regarding specific contaminants should be referred to your local gas utility.

## Ventilation & Flue Pipe Requirements

The Daikin Applied rooftop unit is equipped with an outdoor air hood to supply adequate combustion air. The unit also has a flue outlet assembly and requires no additional chimney, flue pipe, Breidert cap, draft inducer, etc.

## Factory Checkout

This complete furnace was fired and tested at the factory. The unit was fired through several complete sequences of start-up through shutoff to check operation. A check was made of the air switch, gas pressure switch, high limit operation.

This checkout normally eliminates on-the-job start-up problems; however, the equipment is subject to variable job conditions and shipping shocks can change adjustments, cause damage, and loosen connections and fasteners. Therefore, it is necessary to go through the complete start-up procedure even though the unit may appear to be operating properly.

## Installation

### NOTICE

This furnace must be installed by an experienced professional installation company that employs fully trained and experienced technicians. Install the furnace in accordance with the manufacturer's instructions and local codes. In the absence of local codes, follow the National Fuel Gas Code, ANSI Z223.1/ NFPA 54, or the CSA B149.1, Natural Gas and Propane Installation Code.

### WARNING

**Sharp edges hazard. Can cause personal injury or death.** Sheet metal parts, self-tapping screws, clips, and similar items inherently have sharp edges, and it is necessary that the installer exercise caution when handling these items.

## Flue Box

The flue box (Figure 20) is not installed at the factory because it would increase the width of the unit beyond the allowable shipping width.

The flue box must be installed over the combustion exhaust openings. All holes are prepunched, the fasteners are furnished and everything is shipped inside the fan section.

1. Remove and discard the shipping covers.
2. Position the flue box over the exhaust openings.
3. Line assembly holes up.
4. Install screws to fasten the flue box to the side of the unit.

Figure 20: Flue Box Installation

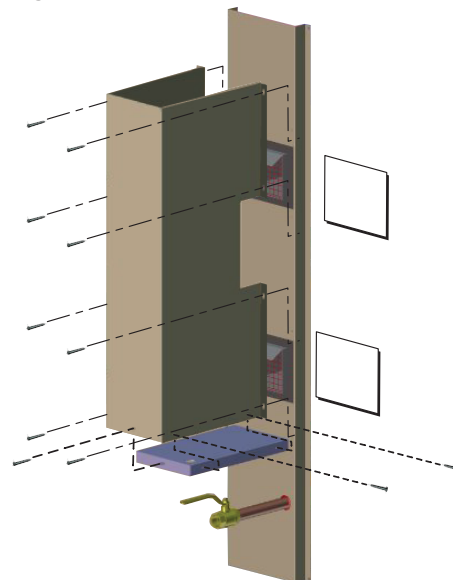

## Outdoor Air (OA) Hood

The OA hood (Figure 21) is not installed at the factory because it would increase the width of the unit beyond the allowable shipping width. The hood is shipped in a box in the fan section.

The OA hoods must be installed over the outdoor air openings.

1. Remove and discard the shipping covers.
2. Attach the grille to the hood bottom opening.
3. Position the hood over the OA openings.
4. Line assembly holes up.
5. Install screws to fasten the OA hood.

The OA hoods must be installed before the furnace is operated.

**Figure 21: Outdoor Air (OA) Hood Installation**

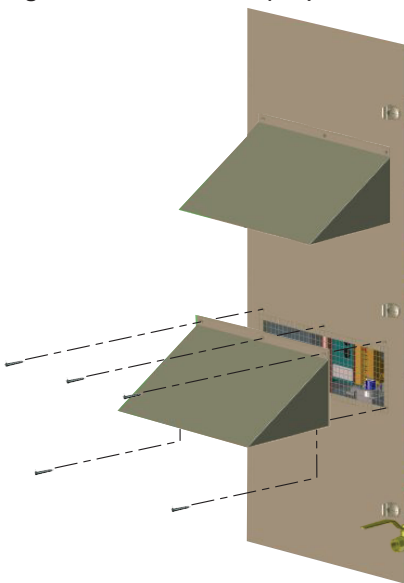

## Electrical

The Daikin Applied burner receives its electrical power from the main unit control panel. No additional power wiring must be routed to the burner. The sequencing of the burner is also controlled through this panel and therefore is factory wired. No additional wiring will be required.

### DANGER

**If you do not follow these instructions exactly, a fire or explosion may result causing property damage, personal injury, or loss of life.**

- A. This appliance does not have a pilot. It is equipped with an ignition device which automatically lights the burner. Do not try to light the burner by hand.
- B. Before operating, smell all around the appliance area for gas. Be sure to smell next to the floor because some gas is heavier than air and will settle on the floor.

#### **What to do if you smell gas:**

- Do not try to light any appliance.
- Do not touch any electric switch, do not use any phone in your building.
- Immediately call your gas supplier from a phone in a neighboring building. Follow the gas supplier's instructions.
- If you cannot reach your gas supplier, call the fire department.
- C. Use only your hand to push in or turn the gas control knob. Never use tools. If the knob will not push in or turn by hand, don't try to repair it, call a qualified service technician. Force or attempted repair may result in a fire or explosion.
- D. Do not use this appliance if any part has been under water. Immediately call a qualified service technician to inspect the appliance and to replace any part of the control system and any gas control which has been under water.

## Gas Pressure Requirements

The pressure furnished to the main gas valve must not exceed 13.9" WC. When the supply pressure is above 13.9" WC, a high pressure regulator must precede the appliance gas pressure regulator. The inlet gas pressure must not exceed the maximum pressure rating of the high pressure regulator, and the outlet pressure must furnish gas to the appliance pressure regulator within the pressure range mentioned above.

## Gas Piping

Gas piping must be sized to provide the minimum required pressure at the burner when the burner is operating at maximum input. Consult your local utility on any questions on gas pressure available, allowing piping pressure drops, and local piping requirements.

Install all piping in accordance with the [National Fuel Gas Code](#) (ANSI Z223.1), (NFPA 54-1999) and any applicable local codes.

The weight of the field-supplied gas pipe must be supported by field-installed brackets or hangers.

The proper size piping must be run from the meter to the gas burner without reductions. Undersized piping will result in inadequate pressure at the burner. The pressure will be at its lowest when it is needed the most, at times of maximum demand. Therefore, it can cause intermittent hard-to-find problems because the problem may have left before the service technician has arrived. Avoid the use of bushings wherever possible.

Remove all burrs and obstructions from pipe. Do not bend pipe; use elbows or other pipe fittings to properly locate pipe.

A drip leg and a manual shut-off must be installed in the vertical line before each burner such that it will not freeze. Install unions so gas train components can be removed for service. All pipe threads must have a pipe dope which is resistant to the action of LP gas. After installation, pressurize the piping as required and test all joints for tightness with a rich soap solution. Any bubbling is considered a leak and must be eliminated. Do not use a match or flame to locate leaks.

## Gas Piping Routing Into Unit

### On-The-Roof Piping

1. Remove knockout on upright (refer to [Figure 22](#)).
2. Route gas supply pipe through hole. Carefully plan pipe route and fitting locations to avoid interference with swinging of doors, etc.

Figure 22: Piping Schematic

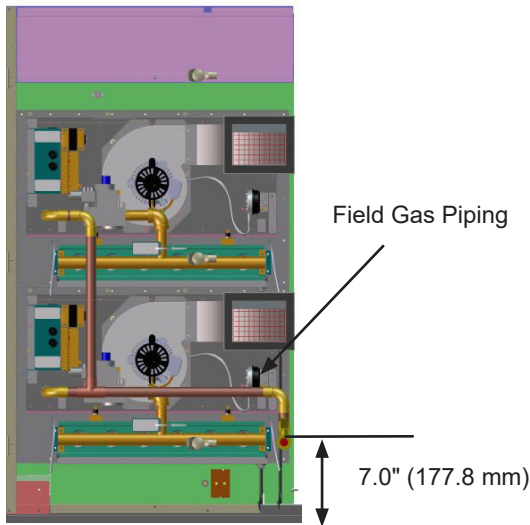

## Field Gas Heat Connections

The appliance must be isolated from the gas supply system by closing off the manual shut off valve during any pressure testing less than 0.5 psi (3.5 kPa) of the gas supply piping system.

The appliance and its individual shut-off valve must be disconnected from the gas supply system during any pressure testing greater than or equal to 0.5 psi (3.5 kPa).

Regulator to be sized for the maximum total Btu input required for the heater(s).

Figure 23: Field Gas Heat Connections

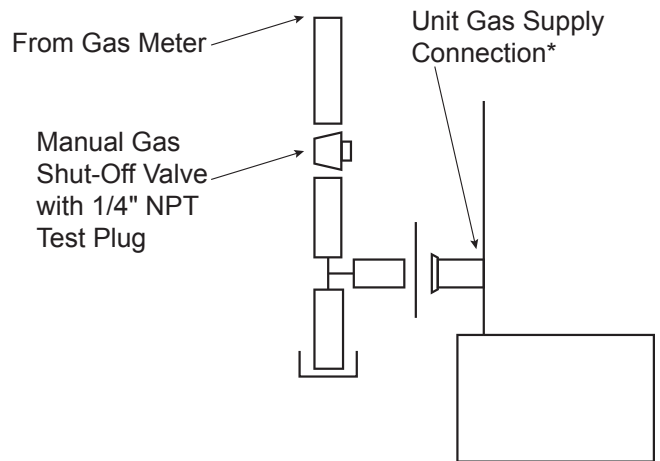

\* Factory-supplied grommet must be utilized

## Altitude Conversion

For elevations up to 2000 feet, rating plate input ratings apply. For high altitudes (elevations over 2000 ft) contact Daikin Applied Parts. See [Table 8](#) for part numbers. Or contact local gas supplier to confirm gas heating value has been devalued for applicable elevations.

**Table 8: Furnace Identification for Altitude**

Elevation (ft.)	Part Number
<b>Natural Gas Fired Furnace with 50 MBH Burners (per tube)</b>	
2000–2999	910166410
3000–3999	910166411
4000–4999	910166412
5000–5999	910166413
6000–6999	910166415
<b>Natural Gas Fired Furnace with 45 MBH Burners (per tube)</b>	
2000–2999	910166412
3000–3999	910166416
4000–4999	910166417
5000–5999	910166415
6000–6999	910166418
<b>LPG Gas Fired Furnace with 50 MBH Burners (per tube)</b>	
2000–2999	910166419
3000–3999	910166420
4000–4999	910166421
5000–5999	910166422
6000–6999	910166424
<b>LPG Gas Fired Furnace with 45 MBH Burners (per tube)</b>	
2000–2999	910166425
3000–3999	910166422
4000–4999	910166427
5000–5999	910166428
6000–6999	910166429

## Size 800 MBH Fuel Conversion

The 800 MBH assembly combines a 400 MBH staged and 400 MBH modulating burner to achieve 800 MBH capacity. Therefore, conversion from NG to LP is only possible by ordering both kits, which can be done by contacting Daikin Applied's aftermarket parts group.

**Table 9: 800 MBH Burner NG to LP Conversion Kit Part Numbers**

Description	Part Number
Conversion kit to LP - Staged Burner	300075071
Conversion Kit to LP - Modulating Burner	300075072

**Figure 24: Maxitrol M520B Modulating Valve**

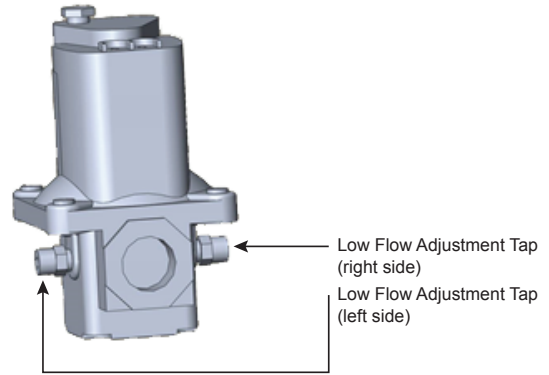

### For Modulating Furnace:

1. Read gas pressure at the Inlet Pressure Tap of the Honeywell VR8305Q Gas Safety Control Valve ([Figure 24](#)) and confirm pressure is at 7.0" WC. Adjust upstream pressure reducing gas regulator as required to obtain 7.0" WC gas pressure.
2. The gas pipe manifold pressure for high fire should be set at 3.2" WC. Adjust the High Pressure Adjustment on the Honeywell VR8305Q Gas Safety Control Valve ([Figure 24](#)) as required. Screwing the adjustment clockwise will increase pressure; counter clockwise will decrease pressure.
3. The gas pipe manifold pressure for low fire (stage #1) should be set at 0.25" WC.

Adjust the Low Pressure Adjustment on the Honeywell VR8305Q Gas Safety Control Valve ([Figure 24](#)) as required until pressure at the Honeywell VR8305Q Gas Safety Control Valve Outlet Pressure Tap reads 0.25" WC. Screwing the adjustment clockwise will increase pressure; counter clockwise will decrease pressure.

Adjust the Maxitrol M520B Modulating Valve ([Figure 24](#)) Low Flow Adjustment screw until the gas pipe manifold pressure reads 0.25" WC.

**Figure 25: Capacity of Pipe Natural Gas (CFH)**

Pipe Length (ft)	With Pressure Drop of 0.3" WC & Specific Gravity of 0.60								
	Pipe Size-inches (lps)								
	½	¾	1	1¼	1½	2	2½	3	4
10	132	278	520	1050	1600	2050	4800	8500	17500
20	92	190	350	730	1100	2100	3300	5900	12000
30	73	152	285	590	890	1650	2700	4700	9700
40	63	130	245	500	760	1450	2300	4100	8300
50	56	115	215	440	670	1270	2000	3600	7400
60	50	105	195	400	610	1150	1850	3250	6800
70	46	96	180	370	560	1050	1700	3000	6200
80	53	90	170	350	530	990	1600	2800	5800
90	40	84	160	320	490	930	1500	2600	5400
100	38	79	150	305	460	870	1400	2500	5100
125	34	72	130	275	410	780	1250	2200	4500
150	31	64	120	250	380	710	1130	2000	4100
175	28	59	110	225	350	650	1050	1850	3800
200	26	55	100	210	320	610	980	1700	3500

NOTE: Use multiplier below for other gravities and pressure drops.

**Table 10: Specific Gravity Other Than 0.60**

Specific Gravity	Multiplier
0.50	1.100
0.60	1.000
0.70	0.936
0.80	0.867
0.90	0.816
1.00	0.775
<b>Propane-Air</b>	
1.10	0.740
<b>Propane</b>	
1.55	0.622
<b>Butane</b>	
2.00	0.547

**Table 11: Pressure Drop Other Than 0.3"**

Pressure Drop	Multiplier	Pressure	Multiplier
0.1	0.577	1.0	1.83
0.2	0.815	2.0	2.58
0.3	1.000	3.0	3.16
0.4	1.16	4.0	3.65
0.6	1.42	6.0	4.47
0.8	1.64	8.0	5.15

## Sequence of Operation (Modulating Burner)

### Low Heat Option with Modulation

The following details the sequence of operation for the low heat option.

1. Unit DDC controller calls for heat.
2. Furnace DDC control module receives a call for heat.
3. Furnace safety switches and DDC control are checked for safe conditions.
4. 45 second prepurge cycle starts. Proof of airflow switch is checked for combustion airflows.
5. Spark ignitor is activated.
6. Gas valve receives a signal to open fully.
7. Burner is ignited and runs for 20 seconds in high fire.

**NOTE:** If call for heat is interrupted during this timing, the furnace will be locked in for the 20 seconds cycle.

8. Gas valve and induction blower motor receives a signal to modulate burner output to match the unit discharge air temperature setting.

## Start-Up Procedures

Start-up and service of this equipment must be performed by trained and experienced technicians. It is highly recommended that the initial start-up and future service be performed by Daikin Applied trained technicians who are familiar with working on live equipment. A representative of the owner or the operator of the equipment should be present during start-up to receive instructions in the operation, care and adjustment of the unit.

### WARNING

**Overheating or failure of the gas supply to shut off can cause equipment damage, severe personal injury, or death.**

Turn off the manual gas valve to the appliance before shutting off the electrical supply.

### DANGER

**If you do not follow these instructions exactly, a fire or explosion may result causing property damage, personal injury, or loss of life.**

- A. This appliance does not have a pilot. It is equipped with an ignition device which automatically lights the burner. Do not try to light the burner by hand.
- B. Before operating, smell all around the appliance area for gas. Be sure to smell next to the floor because some gas is heavier than air and will settle on the floor.

#### **What to do if you smell gas:**

- Do not try to light any appliance.
  - Do not touch any electric switch, do not use any phone in your building.
  - Immediately call your gas supplier from a phone in a neighboring building. Follow the gas supplier's instructions.
  - If you cannot reach your gas supplier, call the fire department.
- C. Use only your hand to push in or turn the gas control knob. Never use tools. If the knob will not push in or turn by hand, don't try to repair it, call a qualified service technician. Force or attempted repair may result in a fire or explosion.
  - D. Do not use this appliance if any part has been under water. Immediately call a qualified service technician to inspect the appliance and to replace any part of the control system and any gas control which has been under water.

## Start-Up Responsibility

The start-up organization is responsible for determining that the furnace, as installed and as applied, will operate within the limits specified on the furnace rating plate.

1. The furnace must not operate at an airflow below the specified Minimum Airflow CFM (refer to [Table 7 on page 22](#)). On variable air volume systems it must be determined that the furnace will not be operated if or when system cfm is reduced below the specified minimum airflow cfm.
2. It must be established that the gas supply is within the proper pressure range (refer to [Table 7 on page 22](#)).

## Operating Procedures

### *Before Start-Up*

1. Notify inspectors or representatives who may be required to be present during start-up of gas fuel equipment. These could include the gas utility company, city gas inspectors, heating inspectors, etc.
2. Review the equipment and service literature and become familiar with the location and purpose of the furnace controls. Determine where the gas and power can be turned off at the unit and before the unit.
3. Determine that power is connected to the unit and available.
4. Determine that the gas piping, meter, and service regulator have been installed, tested, and meet the equipment requirements.
5. Determine that proper instruments will be available for the start-up. A proper start-up requires the following: voltmeter, manometer or gauges with ranges for both manifold pressure and inlet gas pressure.

### *Start-Up Preliminary*

#### **Close gas main.**

1. Check the burner fan wheel for binding, rubbing, or loose setscrews.
2. Check power.
3. Purge the gas lines.
4. Leak check. Using a rich soap-water mixture and a brush, check the gas lines for leaks. Correct all leaks before starting furnace.

## Start-Up

1. Set the thermostat to the lowest setting.
2. Turn off all electric power to the appliance.
3. This appliance is equipped with an ignition device which automatically lights the burner. Do NOT try to light the pilot by hand.
4. Open the control access panel.
5. Turn the gas control clockwise to "OFF".
6. Wait five (5) minutes to clear out any gas. Then, smell for gas, including near the floor. If you smell gas, STOP! Follow step "B" in the DANGER label on this page. If you don't smell gas, proceed to the next step.
7. Turn the gas control counter-clockwise to "ON".
8. Close the control access panel.
9. Turn on all electric power to the appliance.
10. Set thermostat to desired setting.
11. If the furnace will not operate, refer to "[Turning off Gas to the Unit](#)", and call your service technician or gas supplier.

## Turning off Gas to the Unit

1. Set the thermostat to the lowest setting.
2. Turn off all electrical power to the appliance if service is to be performed.
3. Open the control access panel.
4. Turn the gas control knob clockwise to "OFF". Do not force.
5. Close the control access panel.

## Service

The furnace DDC controller has diagnostic information for troubleshooting the furnace operation. The ignition control module has a LED light that will flash when an abnormal condition occurs. See [Table 12](#) for an explanation of the diagnostic information.

## Maintenance

Planned maintenance is the best way to avoid unnecessary expense and inconvenience. Have this system inspected at regular intervals by a trained and experienced service technician. The following service intervals are typical for average situations but will have to be adjusted to suit your particular circumstances.

Fuel pressure settings and control settings should be made only by persons thoroughly experienced with the burner and control system, and must not be tampered with by persons without such experience.

Always replace covers on burner controls and boxes as the electrical contacts are sensitive to dust and dirt. Perform maintenance of controls, gas valves, and other components in accordance with instructions contained in the manufacturer's bulletins.

### Monthly

Check air filters and replace if dirty.

### Twice Yearly

**Burner Air** - Check burner fan wheel for dirt buildup and lint. Check combustion air intake louver and flue box for dirt buildup and accumulation of windborne debris.

**Cleaning** - Inspect flue tubes and combustion chamber, cleaning as required. Keep burner vestibule clean. Dirt and debris can result in burner air blockages.

### Yearly

**Heater and Ventilating systems** - Inspected by a qualified service agency once a year.

**Gas Train** - Check all valves, piping and connections for leakage. Inspect and clean flame rod, ignition electrode, and burner manifold.

**Condensate Pan/Drain/P-Trap** - Check pan, drain, and p-trap.

# Ignition Control Module for Modulating Gas Furnace (240 MBH Furnace Only)

Figure 26: Typical Modulating Gas Furnace Electrical Schematic with Sensor

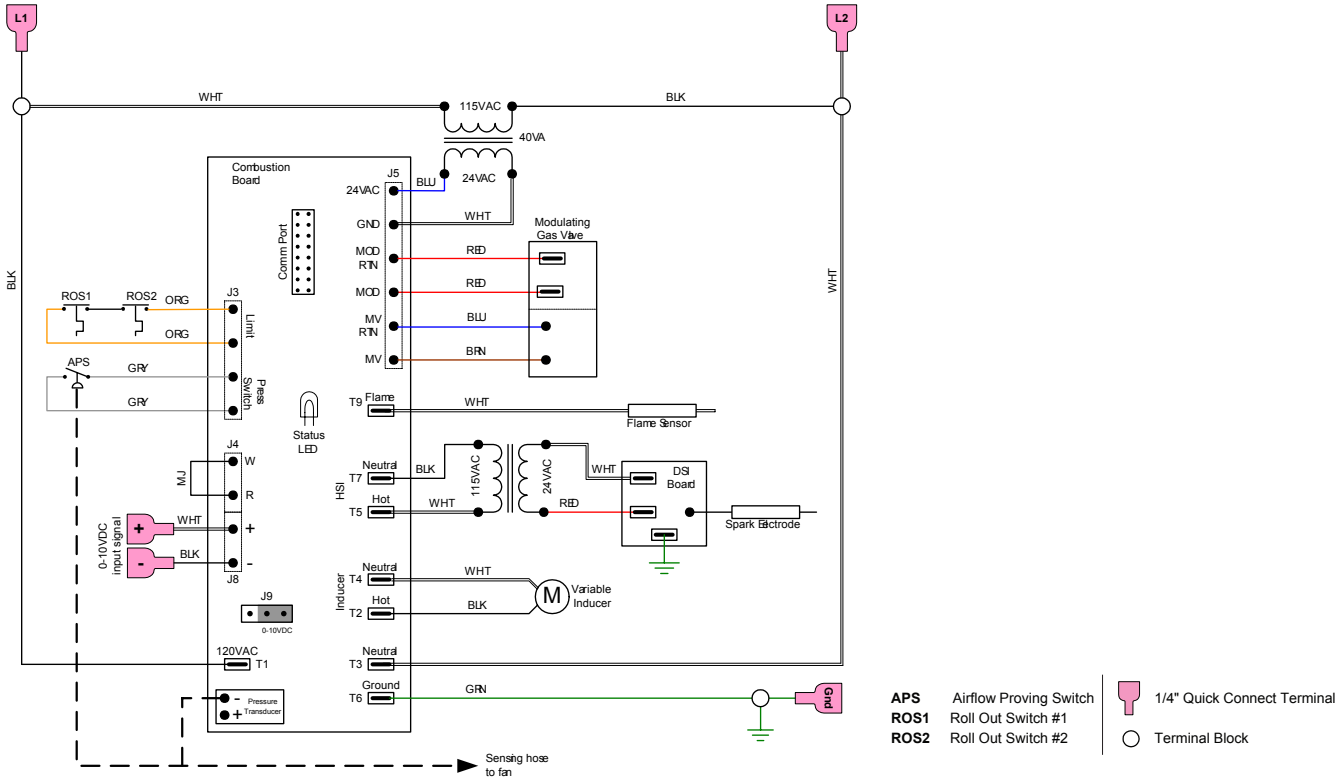

## Variable Furnace Controller

Daikin Applied's furnace controller is an electronic device that delivers full control of the modulating furnace. Control includes sequencing, ignition, safety, modulation of the control valve, and the induced draft motor. Inputs to the furnace control board are an 0-10V signal. The analog signal will modulate the burner down to 25% of full load. Safety inputs include pressure line and electrical connection from the airflow proofing switch and electrical connection from the rollout switches. Control board outputs are to the igniter board, modulating gas valve, and to the induce draft motor.

## Ignition Control Module LED Diagnostics

The LED indicators (Table 12) can be used to diagnose faults associated with the modulating gas furnace.

Table 12: LED Indicator and Fault Conditions

Indicator	Fault Condition
Steady Off	No power or control hardware fault Indicator Fault Condition
Steady On	Control fault detected or no 24 VAC power
1 Flash	Combustion fan motor energized, pressure switch open
2 Flashes	Inducer air pressure reads above zero level when the inducer is off
3 Flashes	Flame is on when it should be off or flame is off when it should be on
4 Flashes	Gas valve is on when it should be off or gas valve is off when it should be on
5 Flashes	Safety relay is on when it should be off or safety relay is off when it should be on
6 Flashes	Excessive plenum temperature
7 Flashes	High limit switch is open or fuse is open
8 Flashes	Pressure switch failed to operate or modulation current is incorrect
Slow Flash	Normal operation - no call for heat
1 Slow	Flash Call for heat
2 Slow	Flashes Gas on - call for heat
3 Slow	Flashes Gas on - no call for heat
Rapid Flash	Retry

# Ignition Control Module for Modulating Gas Furnace (300 & 400 MBH Furnace Only)

Figure 27: Typical Modulating Gas Furnace Electrical Schematic with Sensor

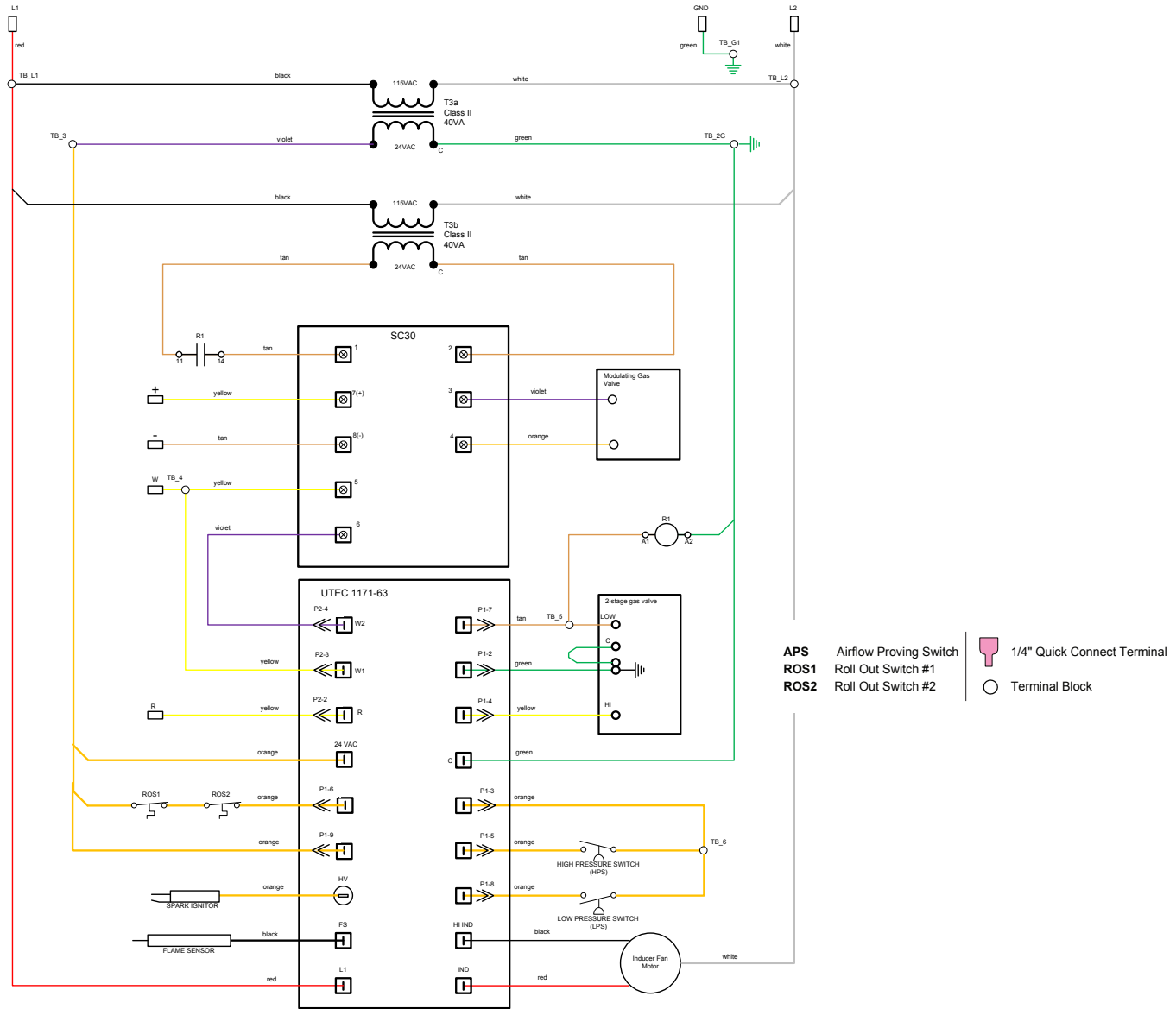

## Variable Furnace Controller

Daikin Applied's furnace controller is an electronic device that delivers full control of the modulating furnace. Control includes sequencing, ignition, safety, modulation of the control valve, and the induced draft motor. Inputs to the furnace control board are an 0-10V signal. The analog signal will modulate the burner down to 25% of full load. Safety inputs include pressure line and electrical connection from the airflow proofing switch and electrical connection from the rollout switches. Control board outputs are to the igniter board, modulating gas valve, and to the induce draft motor.

## Ignition Control Module LED Diagnostics

The LED indicators can be used to diagnose faults associated with the modulating gas furnace.

**Table 13: Modulating Ignition Control Troubleshooting Guide (UTEC 1171 Ignition Board)**

LED Indicator	System Status	Fault Description	Possible Causes and Corrective Action
Heartbeat	System Normal	N/A	<b>All conditions are normal</b>
2 Flashes	Inducer ON No gas	Combustion air flow pressure switch contact is open; combustion inducer fan is running	<b>Pressure switch open with inducer ON</b> 1. Combustion air flow pressure switch hose leaking; repair and/or replace. 2. Combustion air flow pressure switch hose plugged; repair and/or replace. 3. Combustion air flow pressure switch hose fittings plugged or damaged; repair and/or replace. 4. Combustion air pressure hose and/or switch has condensate accumulation; repair and/or replace. 5. Combustion air pressure switch not functioning; replace. 6. Combustion inducer fan not working; repair or replace.
3 Flashes	No Flame	Combustion air pressure switch contact is closed when fan is not running.	<b>Pressure switch close with inducer ON</b> 1. Check wiring to the combustion air flow pressure switch. 2. Check combustion air flow pressure switch continuity with OHM meter; if not open replace.
4 Flashes	Lockout	Failed to ignite after too many failed attempts	<b>Lockout from too many failed ignition tries</b> 1. Confirm gas supply available; verify manifold gas pressure is correct. 2. Verify manual gas shut-off valve is open. 3. Verify Gas Safety Control valve is in On position. 4. Confirm that spark is present. If not, check spark igniter for debris between electrodes, cracked ceramic and damaged or disconnected wire connection. Check ignition wire for cracks, coated with oil and debris. 5. Check for air leaks at inducer fan assembly and flue. 6. Check for recirculation of exhaust flue gases. 7. If all above condition are OK, replace ignition board.
5 Flashes	Lockout	Burners light and then drop out resulting in too many flame failures	<b>Lockout from too many flame losses</b> 1. Check flame sensor ceramic is not cracked; check flame rod for being coated with debris and oil. 2. Check flame sensor wire is connected correctly; not cracked, no abrasions and not covered with debris. 3. Check for recirculation of exhaust gases. 4. Check flame stability and proper location from sensor. 5. Check that pressure switch is not dripping due to loss of pressure.
6 Flashes	No Flame	Inducer fan is running on high speed, burners are OFF, high limit is open.	<b>High temperature switch open</b> 1. Check temperature rise and air flow over furnace heat exchanger. 2. If high limit does not reset, change high limit switch.
7 Flashes	No Flame	Rollout switch has tripped open	<b>Rollout switch open</b> 1. Check for blockages in exhaust vent assembly. 2. Check for air leaks inside the burner compartment. 3. Reset the Rollout switch and observe flame for any signs of rollout.
8 Flashes	Lockout	Flame is present without any call for heat	<b>Flame present with gas OFF</b> 1. Verify there is no voltage to the gas valve. 2. Check gas line pressure making sure it is not higher than allowed by gas valve manufacturer. 3. If valve is not energized, check for gas flow. If gas is flowing, replace gas valve; verify line and manifold gas pressure are correct.
9 Flashes	Lockout	Exceeded max limit trips in one call for heat	<b>Exceeded maximum limit trips in on call for heat (5)</b>

# Modulating Hot Gas Reheat

The reheat coil option comes complete with an aluminum micro channel coil and modulating hot gas valves for leaving air temperature control.

On a call for dehumidification, the unit will enable the supply to be over-cooled by the DX coil. Hot gas from the unit condenser will be routed to an indoor coil downstream of the DX coil to reheat the air. Hot gas reheat valves will control how much hot gas is routed to the indoor coil to maintain a discharge air setpoint (Figure 28).

Figure 29: Ideal for Neutral Air Ventilation Control

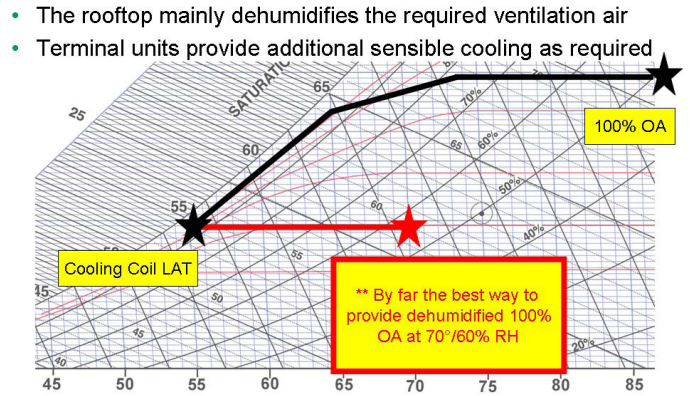
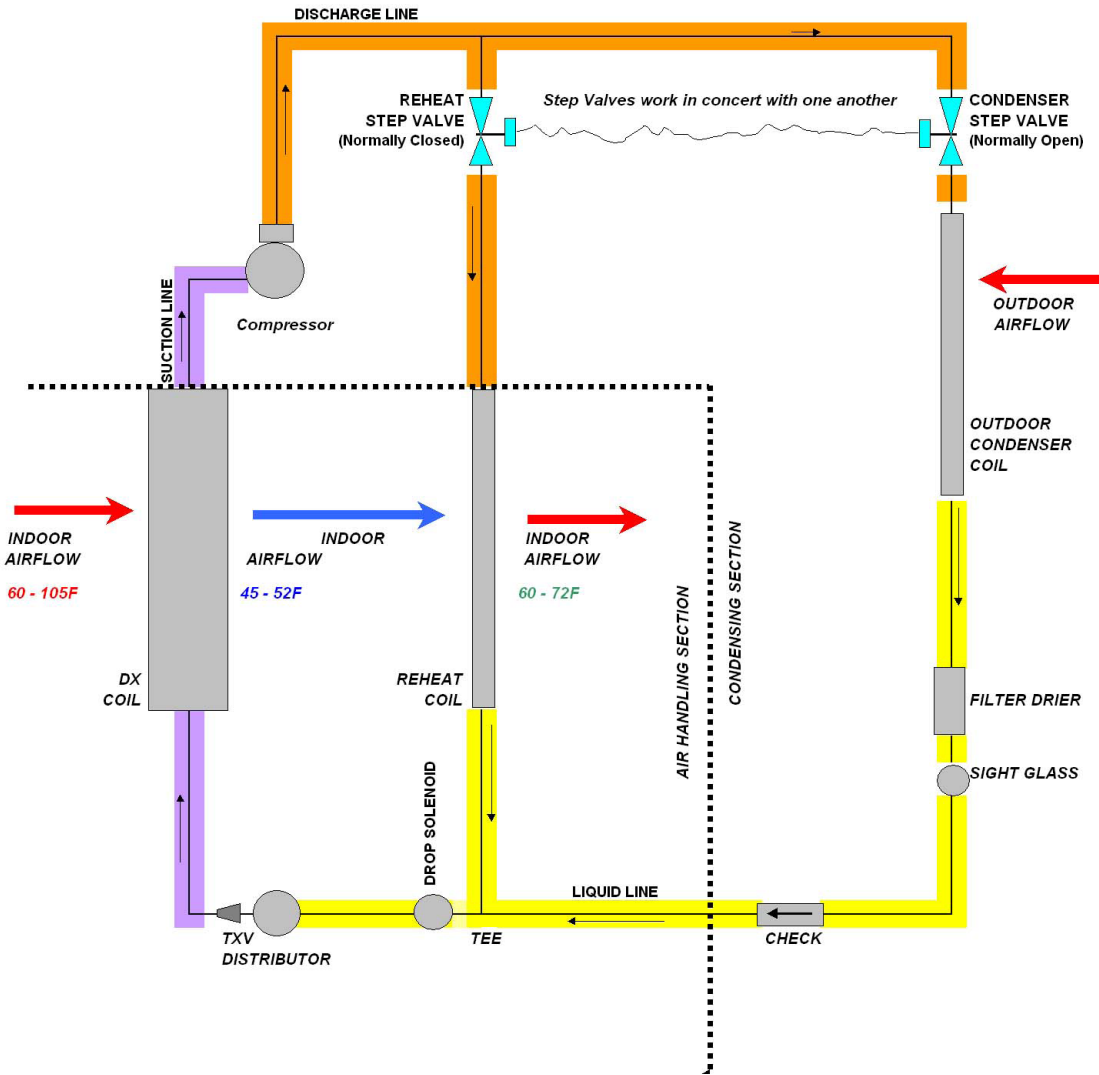

Figure 28: Dual 2-Way Valve Refrigeration Schematic



## Dehumidification Initiation

An analog sensor is mounted in the return duct, the space, or outdoors to sense Relative Humidity. The location is selected by setting the Sensor Location value on the keypad to Return, Space, or OAT. OAT can only be selected for units with DAT control. Dehumidification is disabled when the unit is in either the Heating or Minimum DAT state. When Dehumidification is enabled, Dehumidification operation is initiated when Humidity Control is set to either Relative Humidity or Dew Point and that value rises above the appropriate setpoint by more than half its deadband. Economizer operation is disabled in the Dehumidification mode so the unit immediately transitions to Cooling if Dehumidification is initiated in Economizer state.

## Dehumidification Termination

Dehumidification is terminated if the selected variable, Relative Humidity or Dew Point, drops below the appropriate humidity setpoint by more than half its deadband. Dehumidification is also terminated if cooling is disabled for any reason or the unit enters either the Heating or Minimum DAT state. For units with compressors, the number of cooling stages is reduced by one and control reverts to normal control when dehumidification is terminated in the Cooling state. Another compressor stage change could then occur after one Cooling Stage Time has elapsed.

## Control & Arrangement

In conjunction with dehumidification, MHGRH is used to raise the temperature of the cooled air to a desirable value. MHGRH is comprised of a parallel coil arrangement, with both the condenser and reheat coils of the micro channel type, dual reheat valves (which operate in concert with one another) and a check valve. MHGRH components will always be installed in circuit #2.

During Dehumidification control w/modulating Hot Gas Reheat (MHGRH) an analog signal (0-10VDC) is controlled as described below.

- A PI Loop is used to control the HGRH valves to maintain the Discharge Air Temperature from the reheat coil.
- Compressor staging during reheat (or dehumidification) will be controlled by the Leaving DX Coil Temperature. For increased dehumidification during reheat, the standard default compressor staging range is 45 - 52°F (7.2 - 11.1°C).
- When dehumidification is active in the Cooling state, the reheat set point equals the DAT Cooling Setpoint. For DAT units, this is the normal DAT set point resulting from any reset. For Zone Control units, this set point is the result of a PI Loop based on the Control Temperature.
- Communication with the reheat control valves is accomplished by providing a 0-10VDC signal to a pair of interface boards which in turn supply the control signal to the reheat valves (step type).
- In the Fan Only state, no sensible cooling is required, but dehumidification mode will still be enabled if the dew point or humidity sensor is not satisfied. Reheat set point varies from a maximum value (default 65°F (18.3°C)) when the Control Temperature is at or below the heating changeover setpoint to a minimum value (default 55°F (12.8°C)) when the Control Temperature is at or above the cooling changeover setpoint.
- Lead/Lag Arrangement w/ MHGRH (when applicable)
  - Alternate staging with circuit #1 as lead will be the standard default arrangement.
  - During cooling mode, circuit #1 will lead and load up before starting circuit #2.
  - During reheat mode, circuit #2 will lead and load up before starting circuit #1.
  - For reheat operation, compressor(s) in circuit #2 must be active. If the unit is operating in the cooling mode when a call for dehumidification/reheat arises, circuit #2 will become the lead and the controller will bring on an additional stage of cooling for dehumidification. If any compressors in circuit #1 are operating at this moment they will be switched over to compressors in circuit #2. Dehumidification operation is disabled if circuit #2 is disabled for any reason.

Figure 30: Modulating Hot Gas Reheat Schematic

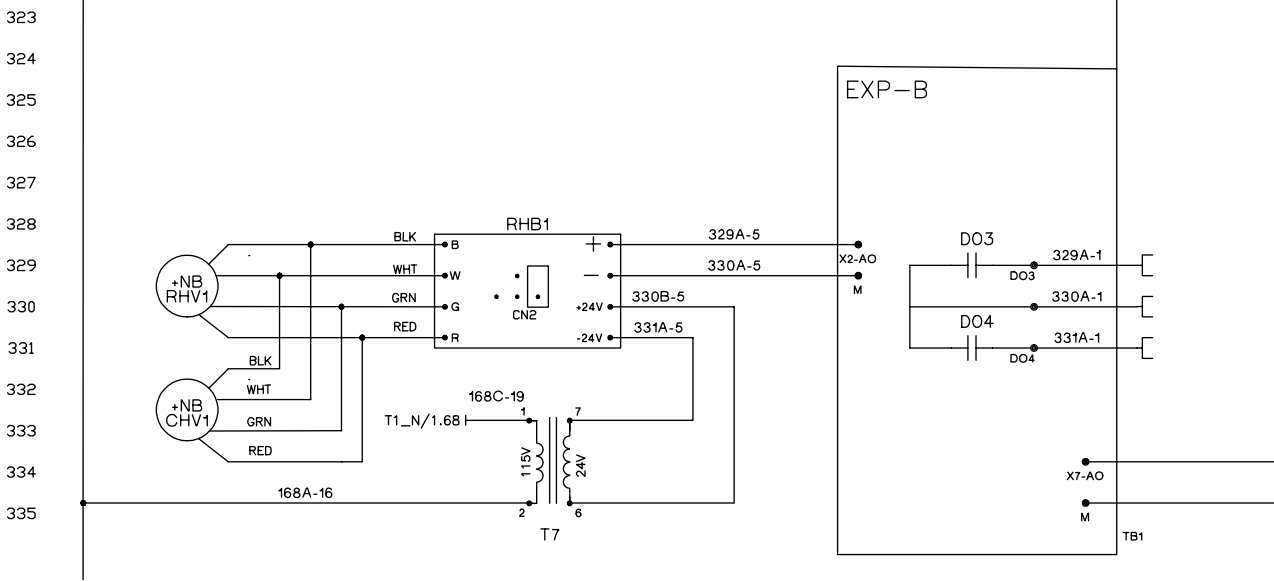

- In the reheat mode, the minimum position for the reheat valves is 10% (1.0 VDC). The controller will modulate the reheat valves from this starting position.
- Reheat valve(s) must be at 0% (0 VDC) position before starting the first compressor in the reheat circuit to prevent pressure spikes.
- Upon termination of dehumidification (reheat), the maximum ramp down or decay rate of the reheat control valves shall be 1% per sec (or 0.1V per sec).
- Upon termination of dehumidification (reheat), staging of compressor(s) is delayed for 1 minute after reheat capacity = 0% (0 VDC).
- Every 24 hours, the reheat control valves will be driven to their maximum position (10VDC) and then returned to their normal operating position (0VDC). If unit is operating in cooling or dehumidification (reheat) at the prescribed time it will be deferred to the next time.
- Dehumidification status can now be found under the MTIII main system menu. Reheat capacity (valve position) can also be found under the main system menu, display based on percentage (0-100%).

# Optional Hot Water Heat

## Hot Water Heater Design

If the 8th character of the model number is a "W", the rooftop unit was furnished with a factory installed hot water coil (Example: MPS035JW). The hot water coil comes with a piping vestibule for field supplied and installed control valve and piping. The coil is furnished with ODM copper connections. The Maverick commercial rooftop units are available with a low heat (one row coil) or a high heat (two row coil) configuration.

See certified drawings for the recommended piping entrance locations. Seal all piping penetrations to prevent air and water leakage.

**NOTE:** Factory installed piping is copper. Dissimilar metal within the plumbing system can cause galvanic corrosion. To avoid corrosion, provide proper di-electric fittings as well as appropriate water treatment.

**⚠ CAUTION**

**Coil freeze possible. Can damage equipment.** Follow instructions for mixing antifreeze solution. Some products have higher freeze points in natural state than when mixed with water. The freezing of coils is not the responsibility of Daikin Applied.

Figure 31: Hot Water Heating Schematic

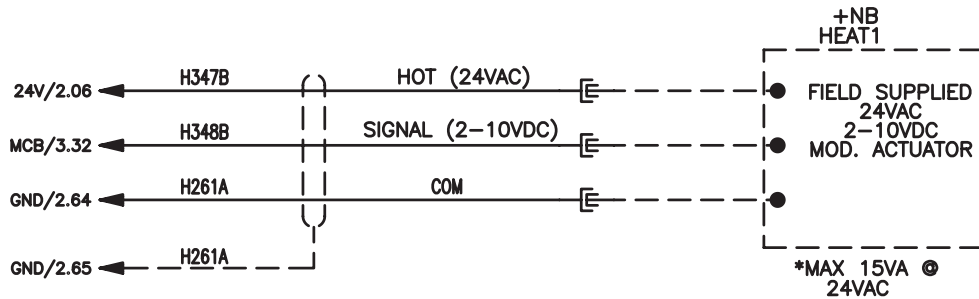
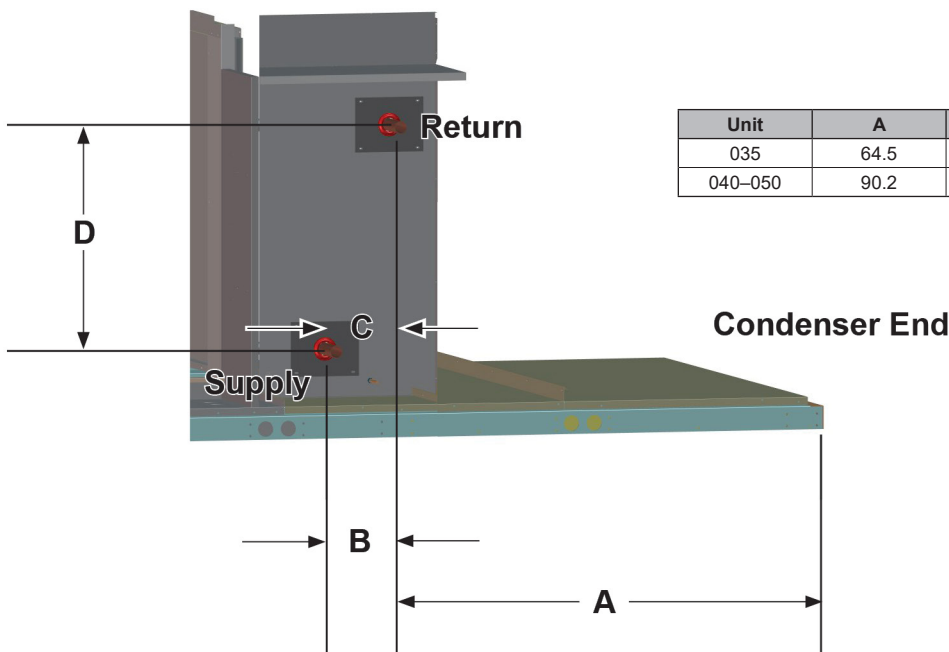

Figure 32: Hot Water Heat Vestibule



Unit	A	B	C	D
035	64.5	8.5	8.5	28.5
040-050	90.2	8.5	8.5	28.5

## Hot Water Pressure Drop Data

Figure 33: MPS 035 Low and High Heat

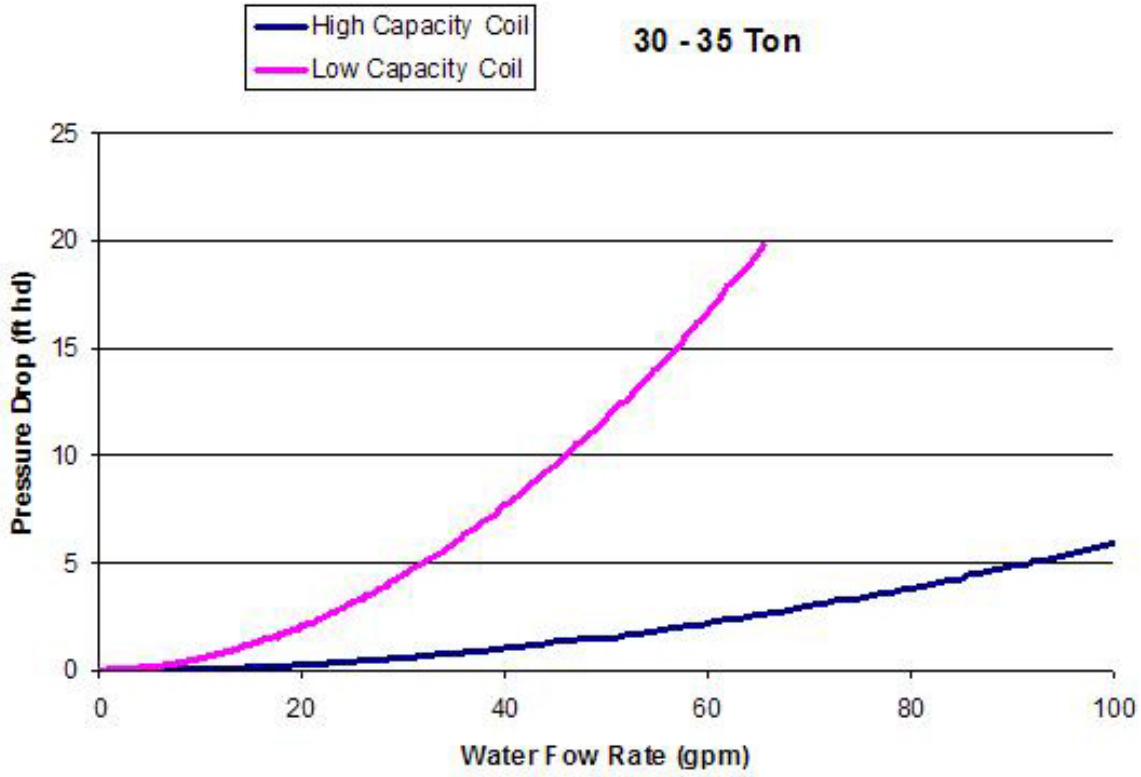
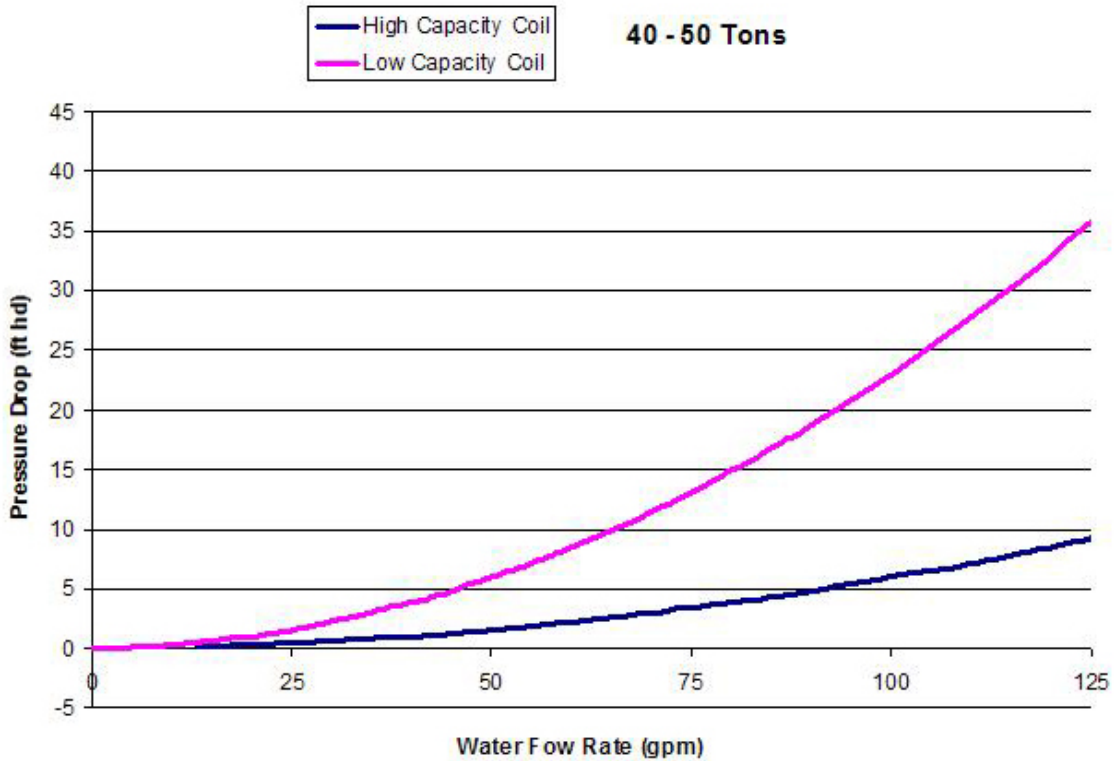

Figure 34: MPS 040 – 050 Low and High Heat



# Optional Energy Recovery Wheel

## Energy Recovery Wheel Design

When a unit is equipped with an optional enthalpy wheel, energy recovery is provided by drawing outside air across half of the enthalpy wheel and drawing exhaust air across the other half. Latent heat and sensible heat are transferred from the hotter and moist exhaust air to the colder and dry outside air during winter conditions. Latent heat and sensible heat are transferred from the hotter and moist outside air to the cooler and dry exhaust air during summer conditions. Energy recovery control consists of starting and stopping an exhaust fan, modulating the speed of the exhaust fan, starting and stopping an enthalpy wheel, optionally controlling the speed of the enthalpy wheel and opening and closing a set of bypass dampers. The outdoor dampers are controlled in the normal manner.

## Arrangements

Three arrangements are offered for the enthalpy wheel:

1. Single enthalpy wheel with economizer and bypass (see [Figure 35](#)). This arrangement is available for all units.
2. Single enthalpy wheel without economizer (100% outdoor air unit) for airflow up to about 7000 CFM. Only available on certain sizes.

## Wheel Construction

Your Daikin Applied enthalpy wheel is delivered completely assembled and ready to run. The wheel is built to provide many years of trouble free service following proper installation and performance of the minimal maintenance requirements.

## Definitions

The following are descriptions of various components related to the enthalpy wheel construction (see [Figure 35](#)):

**Bearing, external** – The wheel and bearing rotate on the shaft, no field lubrication is required.

**Brush seal** – The seal used for both the circumferential seal and the inner seal in the cassettes. They are constructed of nylon brush and configured to seal against the enthalpy wheel band in the case of the circumferential seal, and against the wheel face in the case of the inner seal. These seals are full contact seals, have an integral clip, and they are clipped to the cassette face panel cutout (circumferential) or to the (inner) post.

**Cassette** – The steel structure that houses the rotor. Cassettes are of punched sheet metal panelized construction.

**Enthalpy wheel** – A generic name for an energy conservation wheel. The term “enthalpy” refers to an air stream’s total energy (temperature and humidity level).

**Exhaust air** – The air stream that is exhausted to the outside. Exhaust air is building return air that has been run through the enthalpy wheel.

**Heat wheel** – Synonymous with an enthalpy wheel, energy conservation wheel, or total energy recovery wheel. Some heat wheels are sensible only wheels and should not be confused with Daikin Applied total energy recovery wheels.

**Hub** – The center support of an enthalpy wheel.

**Latent energy** – Latent energy, in the context of enthalpy wheel discussions, is the work done by the wheel to transfer moisture from one air stream to another. Latent work is accompanied by humidity changes in the air streams.

**Media** – The chemical composite part of the enthalpy wheel which actually performs the latent and sensible exchange.

**Outdoor air** – The air stream that is brought in from the outside. Outdoor air becomes supply air after going through the enthalpy wheel.

**Purge** – A small segment of supply air defined by the gap between the inner seal on the outdoor air edge of the center post and the supply air edge of the center post. The purge angle is adjustable. The purge captures the small amount of supply air captive in the enthalpy wheel when the wheel moves from return to supply and routes it to return to minimize cross contamination.

**Return air** – The air stream that is returned from the building. Return air becomes exhaust air after going through the enthalpy wheel.

**Rotor** – The part of an enthalpy wheel that performs the energy exchange and consists of the wheel media, hub, spokes and band.

**Sensible heat** – Sensible energy, in the context of enthalpy wheel discussion, is the work done by the enthalpy wheel to transfer heat from one air stream to another. Sensible work is accompanied by temperature changes in the air stream.

**Supply air** – The air stream that is supplied to the building space. Supply air is outdoor air that has been run through the enthalpy wheel.

Figure 35: Wheel Construction (Side-by-Side)

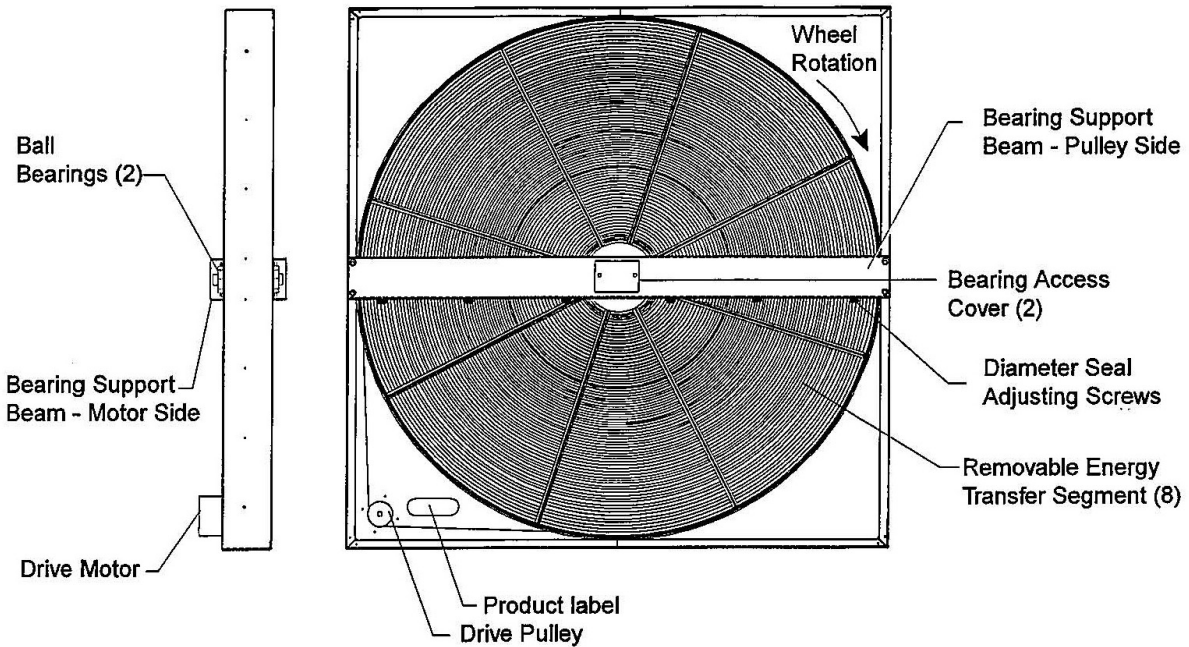

(1) Currently, only the Over-Under configuration is offered on Daikin Applied roof-top systems and air handlers.

### Purge and Pressurization

Pressurization is critical to minimize crossover from exhaust to [Figure 36](#): Purge Detail supply and to allow the purge to operate.

Figure 36: Purge and Pressurization

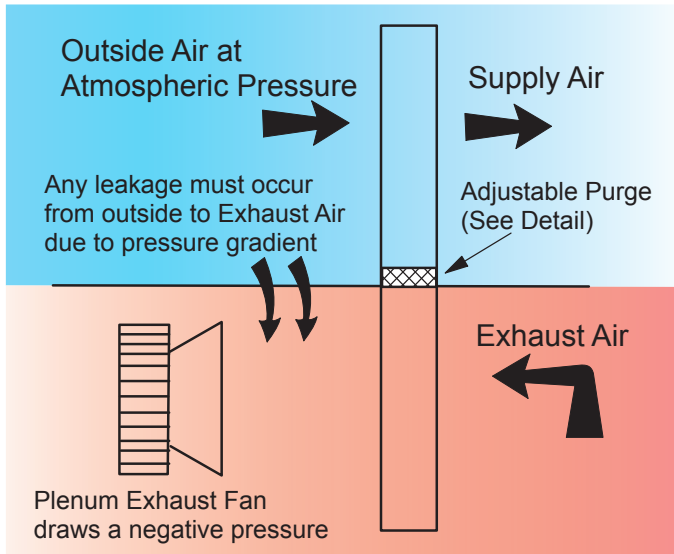

NOTE:  
Maintain the pressure gradient to prevent cross contamination from the Exhaust to Outside Supply Air

Figure 37: Purge Detail

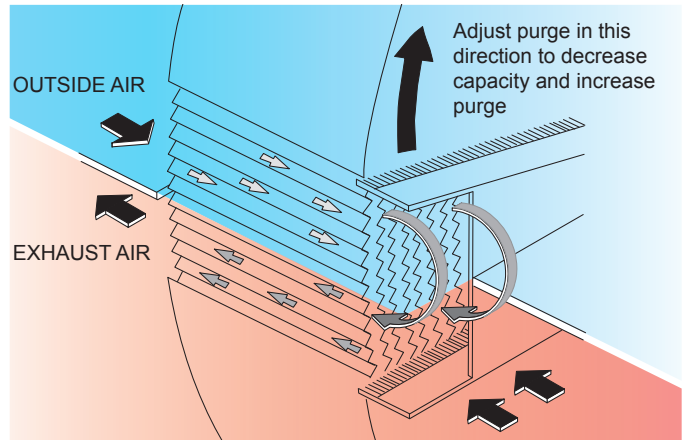

## Drive Motor

The enthalpy wheel comes standard with a constant speed drive motor which is prewired to turn in the proper direction.

## Frost Protection Option

During extremely cold winter conditions, exhaust air stream To circumvent this possibility, Daikin Applied offers three factory installed frost protection options with the MicroTech system.

## Defrost ON/OFF Control (Standard)

With this method the enthalpy wheel is stopped periodically for a defrost time duration when the outdoor air temperature is below an outdoor frost temperature threshold setpoint.

**Figure 38: Frost Prevention Psychrometric Chart**

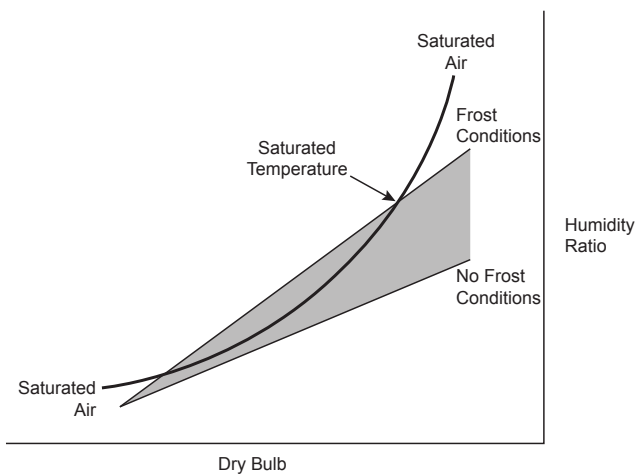

## Constant Speed Frost Prevention

When there is a threat of frost on the enthalpy wheel, the wheel is jogged so that less enthalpy transfer occurs and frosting of the wheel is avoided. Frosting can occur on the enthalpy wheel when the exhaust air leaving the wheel is saturated. This condition occurs when two lines intersect on a psychrometric chart, and it does not occur when these two lines do not intersect (see Figure 39).

## Variable Speed Frost Prevention

When there is a threat of frost on the enthalpy wheel, the wheel is slowed down so that less enthalpy transfer occurs and frosting of the wheel is avoided. Frosting can occur on the enthalpy wheel when the exhaust air leaving the wheel is saturated. This condition occurs when two lines intersect on a psychrometric chart, and it does not occur when these two lines do not intersect (see Figure 38).

## Energy Recovery Exhaust Hoods

Units with the optional energy recovery section have one or two (depending on model) exhaust hoods. Each hood is shipped in three pieces, consisting of one top and two sides. Install exhaust hood over the barometric relief dampers by installing two sides first and then install the top.

## Variable Speed Frequency Control

A variable frequency drive is included with the frost protection option and it controls the speed of the enthalpy wheel. The unit has also been programmed for the recommended range of wheel speed operation. Typical wheel speed is 45 RPM, but the programming can allow for wheel speeds above or below 45 RPM. Check all factory settings to make sure they are consistent with the application.

Enthalpy wheel speed will be controlled by exhaust temperature measurement.

# Outdoor Air Monitor

## Thermal Dispersion Airflow Measurement Technology

Thermal dispersion technology relates the velocity of the air to the power and rise in temperature of a heated element in a moving airstream. A precise bead-in glass thermistor probes the airflow rate and air temperature. Multiple sensing points are used to produce an average velocity for true volumetric airflow (CFM/LPS). Each individual sensor node is calibrated to NIST traceable airflow standards at 16 points, resulting in an accuracy of 2% of the reading.

**Figure 39: Bead-in-Glass Thermistor**

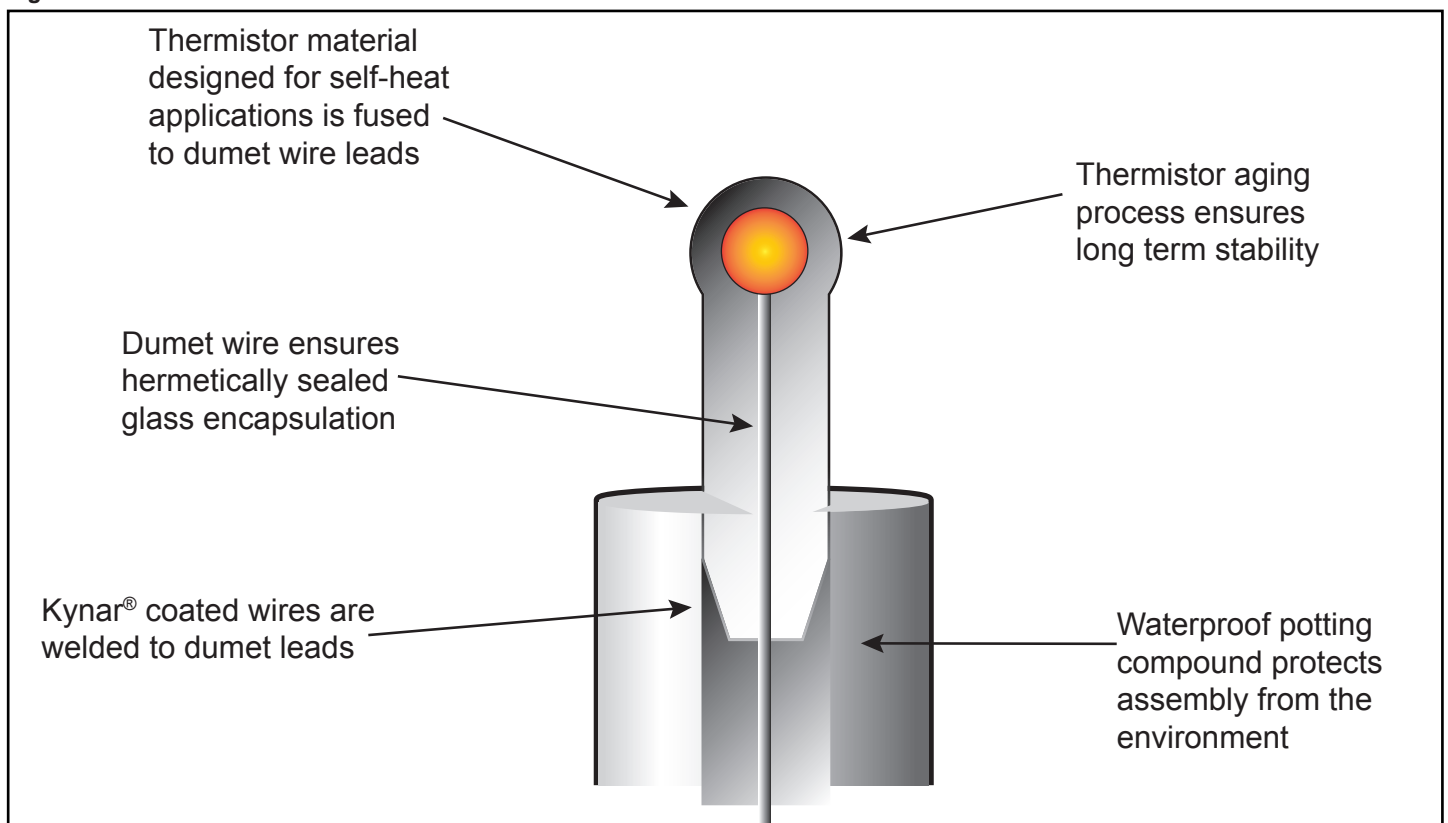

**Figure 40: Bead-in-Glass Thermistor Probe**

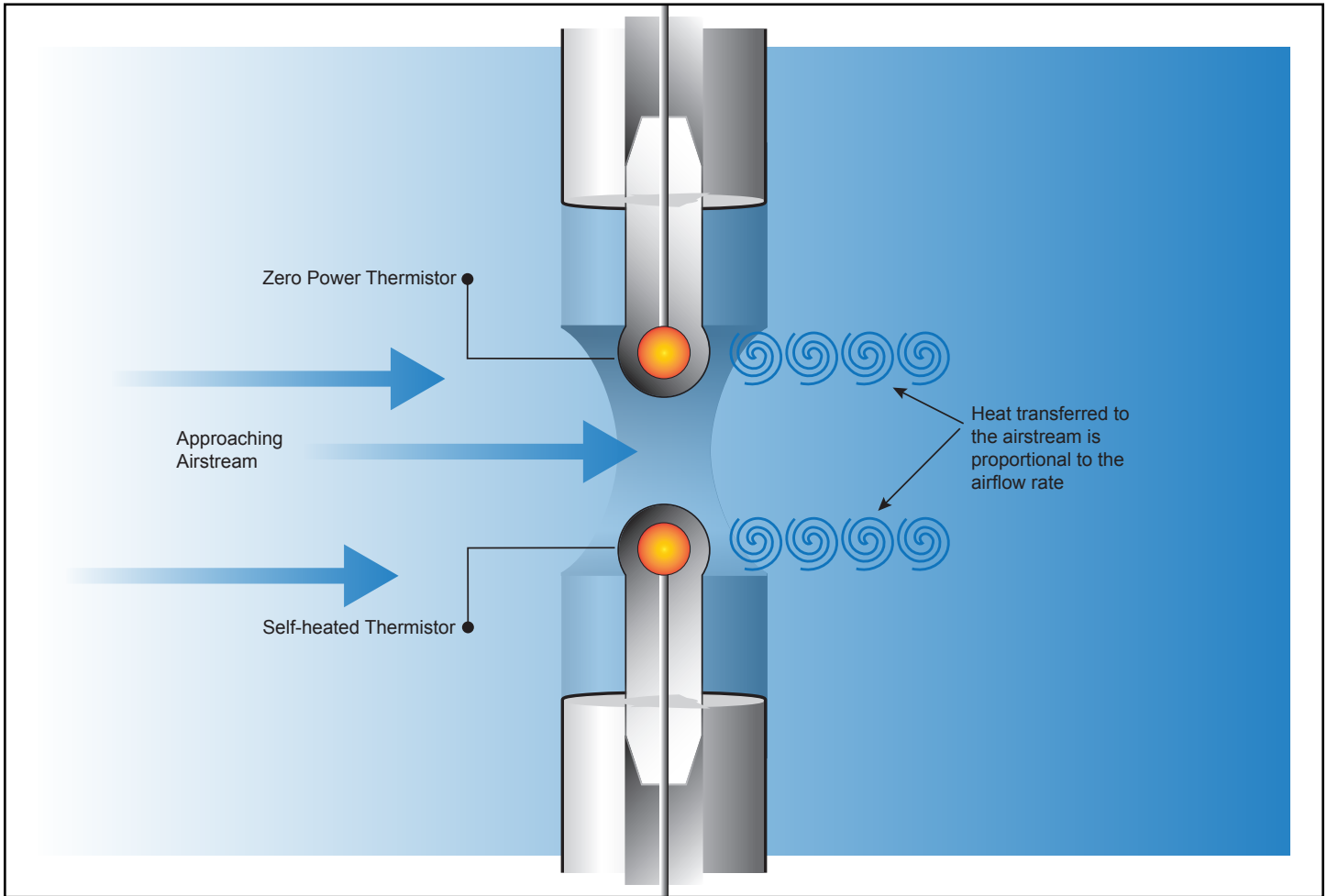

## Connecting to MicroTech Unit Controllers

### Wiring

1. Connect analog control wires from the MicroTech Unit Controller to the outdoor air monitor controller.
  - a. MicroTech unit controller (X4 on the EXP-A) to the controller's analog output terminal 1.
  - b. MicroTech unit controller (M on the EXP-A) to the controller's analog output terminal COM.
2. Power Wires (24 VAC) to the outdoor air monitor controller.
  - a. 24VAC from the unit control panel to the controller terminals L1 and L2.

### Outdoor air monitor controller settings

1. Set Controller SW1 switch to VDC.
2. Set power switch to ON.

### Outdoor Air Monitor Controller Configuration/Set Up

(see [page 47](#) for navigating the controller keypad)

1. Set LCD1 U/M to "CFM"
2. Set AR1 (see [Table 14](#))
3. Set OUT1 U/M =CFM
4. Set OUT1 =0-10V
5. Set FSI (see [Table 14](#))

**Table 14: Settings by Cabinet Size**

Unit size	Economizer and 0-100%	0-30% Area sq.ft. (AR1)	Full scale output CFM (FS1)
Small cabinet	7.3	4.75	10,000
Medium cabinet	10.0	9.5	10,000
Large cabinet	14.5	10.0	10,000

Figure 41: Outdoor Air Monitor Controller

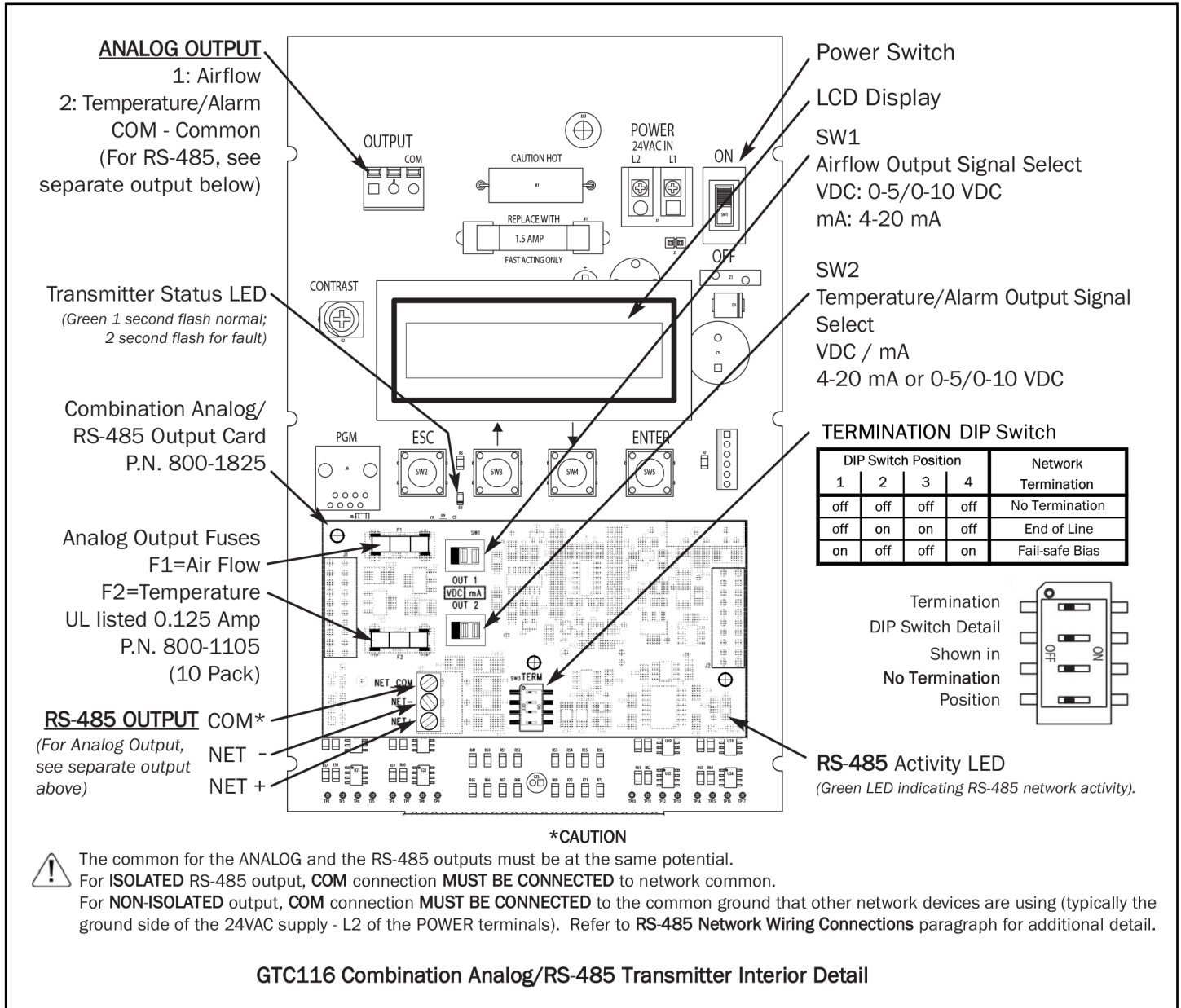

Figure 42: Transmitter Detail

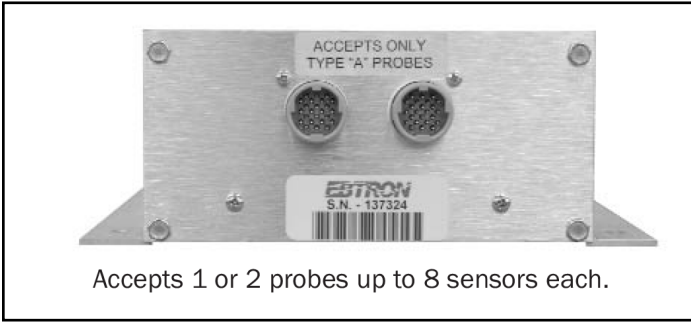

Figure 43: Connector Detail

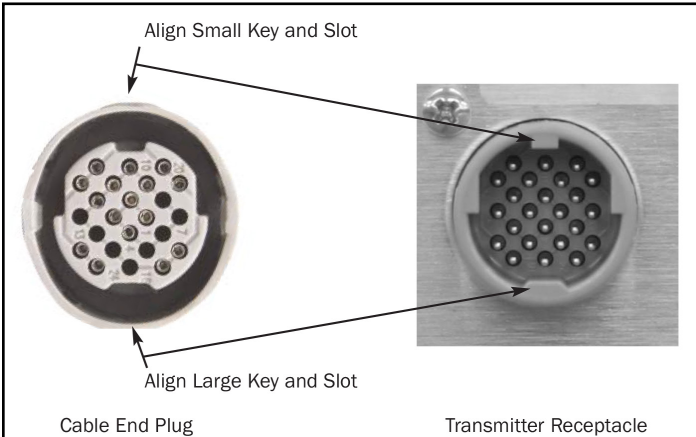
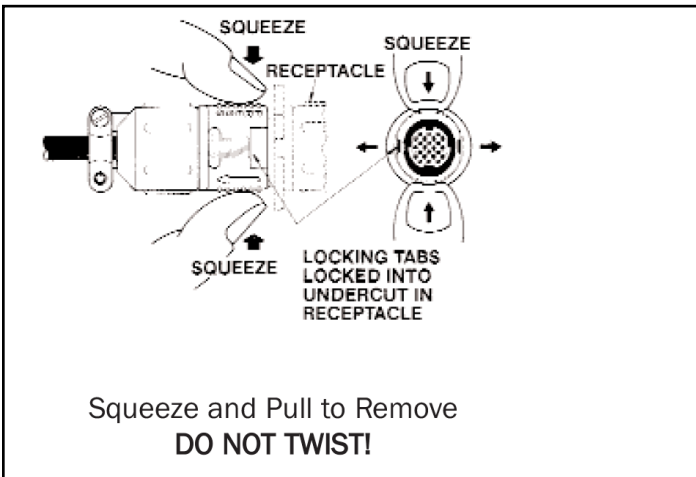

Figure 44: Connector Removal Diagram



## Changing Standard Units

The transmitter is provided with the system of units set to IP (imperial). To change to SI (metric), simultaneously press and release the “UP” and “DOWN” arrow buttons during normal operation. “IP/SI UNITS” will be indicated on the LCD display. Press “ENTER” three times and use the “UP” and “DOWN” arrow buttons until the system of units desired is indicated. Press the “ENTER” button to select changes then press “ESC” twice to return to the normal operating mode. See the unit controller manual for details.

## LCD Display Notifications

Following a brief initialization at power up, the LCD display automatically displays airflow and temperature as all upper case (caps) characters. The display provides additional information on system status and alarm conditions as follows:

### Last LCD Character Shown in Lower Case (Probe Malfunction)

If the last character of the flow rate units on the LCD display is lower case (for example Fpm or CFm), this indicates that an improper/malfunctioning probe is connected to the transmitter.

### All LCD Characters Shown in Lower Case

When all characters of the flow rate units are displayed in lower case (for example cfm) the transmitter is operating in the Field Calibration Wizard mode. Daikin Applied users do not need to use this function.

### LCD Blinks \*\* LOW ALARM \*\*, \*\* HIGH ALARM \*\* or \*\* TRBL ALARM\*\*

The LCD will alternately flash to indicate an active alarm condition for the type of alarm that has been set. The LCD displays airflow/temperature readings between the alarm notifications. Alarm will cease when the alarm is cleared.

## Converting the Analog Output Signal from FPM to CFM (MPS to LPS for SI units scaling)

The transmitter is shipped from the factory with analog output “OUTPUT 1” set to indicate velocity in FPM. To automatically convert this analog velocity output to volumetric flow (CFM or LPS), simply set the \*OUT1 U/M from FPM (default) to CFM in the Setup Menu (See the unit controller manual for details.). If you wish to manually convert the velocity output to volumetric flow (CFM or LPS), simply multiply the indicated output velocity (in FPM or MPS) by the free area of the air flow probe installation location (free area × 1000 for SI units when area is calculated in square meters). For -P sensors, the total free area is programmed into the probe at the factory and is printed on the probe hang-tag. For -F and -B sensor probes, determine the free area following installation in accordance with the installation guidelines.

**NOTE:** The full scale analog output (OUTPUT1) value is determined by the FS1 setting within the SETUP MENU.

## Altitude Correction Adjustment

The Altitude Correction Adjustment allows for correction of airflow readings at the installed site altitude and more precise readings regardless on installed altitude. Refer to the SETUP MENUS for the \*ALT= menu item, and set this value to the installation altitude.

## Adjusting The Digital Output Filter

The digital output filter is useful for dampening signal fluctuations resulting from transient wind gusts on outdoor air intakes or excessive turbulence generated from duct disturbances. The digital output filter range can be set between 0 (OFF) and 99%. Increasing the filter percentage limits the allowable change of the output signal. To change the amount of filtering, enter the Setup menu and set “\*FILTER1={desired value}”.

 **WARNING**

Fluctuations in the airflow output signal are normal. Laboratory research indicates that dampening true fluctuations will result in poor control and a larger dead-band of operation. Therefore, the use of the dampening filters in control devices is not recommended. Warnings indicate potentially hazardous situations, which can result in property damage, severe personal injury, or death if not avoided.

**Table 15: General Troubleshooting**

Problem	Possible Cause	Remedy
No LCD display indication and the green Transmitter Status LED (D3) on the main circuit board is not illuminated.	Power switch not in the "ON" position.	Move the power switch to the "ON" position.
	Improper supply voltage to the power input terminal block.	Ensure that 24VAC power is connected to L1 and L2 of the POWER terminal block and that the voltage with the power switch in the "ON" position is between 22.8 and 26.4 VAC.
	Blown fuse.	Check power wiring. Ensure that multiple devices wired on a single transformer are wired "in-phase". Replace fuse only with a 1.5 amp, fast-acting fuse after the problem has been identified and corrected.
No LCD display indication and the green Transmitter Status LED (D3) on the main circuit board is flashing.	LCD contrast too low.	Turn "Contrast" potentiometer on the main circuit board "clockwise".
The LCD display is scrambled or there is no LCD display indication after touching the switches, LCD display or circuit board.	Static electricity.	Touch an earth-grounded object, such as a duct, to discharge static electricity then reset the power. Avoid direct contact with the LCD display or circuit board.
The LCD display indicates "No Probes".	The power switch on the transmitter was moved to the "ON" position before the sensor probes were connected.	Reset 24VAC power by moving the power switch from the "ON" to "OFF" position and then back to the "ON" position.
The LCD display indicates "DiffSensor Type".	Sensor probes have been mismatched.	Transmitters must have the same sensor type connected (GP1, GF1 or GB1 sensor probes).
The LCD display indicates "Too Many Sensors".	A probe with 5 or more sensors has been connected to a 'Type B' transmitter with 4 receptacles.	Probes with 5 or more sensors are shipped with and require a 'Type A' transmitter with 2 receptacles.
The last digit of the flow rate unit is displayed as a lower case letter. (When the Field Calibration Wizard is engaged, the last character of the flow rate units is displayed as an upper case letter.	The sensor detection system has detected one or more malfunctioning or missing sensors.	Check sensor probe cable connections. If sensor probe connections look OK and match the number of sensor probes indicated on each probe's hang tag.
	A probe with 5 or more sensors has been connected to a 'Type B' transmitter with 4 receptacles.	Probes with 5 or more sensors are shipped with and require a 'Type A' transmitter with 2 receptacles.
The green Transmitter Status LED (D3) on the main circuit board is "ON" but not flashing.	The microprocessor is not running.	Reset 24VAC power by moving the power switch from the "ON" to "OFF" position and then back to the "ON" position.
The green Transmitter Status LED (D3) on the main circuit board is flashing at 1-second intervals.	No problem, normal operation.	No remedy required.
The green Transmitter Status LED (D3) on the main circuit board is flashing at 2-second intervals.	The sensor detection system has detected one or more malfunctioning or missing sensors.	Check sensor probe cable connections. If sensor probe connections look OK and match the number of sensor probes indicated on each probe's hang tag.
	A probe with 5 or more sensors has been connected to a 'Type B' transmitter with 4 receptacles.	Probes with 5 or more sensors are shipped with and require a 'Type A' transmitter with 2 receptacles.
The transmitter indicates airflow when the HVAC system is not operating.	Sensors are sensitive and can measure very low air velocities. If a reading is indicated, there is airflow present where the airflow measuring station is located.	Do not attempt to adjust zero ("offset"). Doing so will result in an error in airflow measurement. The Low Limit airflow cutoff value can be set to force the output signal to zero.

Problem	Possible Cause	Remedy
No output signal can be measured at the OUTPUT terminal block of the transmitter.	Output card is not securely mounted on main circuit board.	Turn the transmitter power "OFF", and then press the output card firmly onto main circuit board. Turn the transmitter power back "ON".
	Blown output fuse (output 1 and output 2 are fused and protected independently on the transmitter).	Make sure that power has not been connected to the output terminal block. Correct the problem and replace with 0.125 amp, fast acting fuse only. Make sure that the host control system is not configured for a 2-wire device (no excitation voltage should be present on the signals from the host controls). Correct the problem and replace with 0.125 amp, fast acting fuse only.
	The Low Limit airflow cutoff value is above the actual airflow reading.	Decrease the Low Limit airflow cutoff value in the Setup menu until it is below the actual airflow reading.
The output signal on the transmitter fluctuates while the flow and/or temperature readings on the LCD are steady.	Electrical interference from other devices is creating noise in the signal wires to the host control system.	The output signal wiring must be shielded. Individually ground one or more of the following points: the signal wire shield at host controls; signal wire shield at the transmitter, or L2 of the power terminal block of the transmitter.
The LCD display does not match the readings indicated by the host control system.	The scaling in the host control system is incorrect.	Compare the current configuration of the transmitter with that of the host control system. Compare the minimum and full scale settings for each output by navigating through the Setup menu.

**Table 16: Transmitter Troubleshooting**

Problem	Possible Cause	Remedy
The host control system is unable to communicate with the transmitter.	Output card is not securely mounted on main circuit board.	Turn the transmitter power "OFF" and press the output card firmly onto main circuit board. Turn the transmitter power back "ON".
	Network signal wiring is not properly connected to the transmitter or the host controls.	Verify that the network signal wires from the host controls are connected to the proper terminals of the OUTPUT block. On the transmitter OUTPUT terminal block, NET+ is for A, NET- is for B and COM for common.
	Network protocol is not properly set on the transmitter.	Set network protocol based on the network requirements and reset transmitter power.
	Network address is not properly set on the transmitter.	Set address based on network requirements and reset transmitter power. The address must be unique for the network.
	Network termination is not properly set on the transmitter.	Set transmitter termination based on network requirements and reset the transmitter power.
The LCD display does not match the readings indicated by the host control system.	The Area or K factor of the transmitter does not match that of the host controls.	Compare the value of the Area or K factor of the transmitter with that of the host control system and make adjustments to ensure a match.
The returned value for airflow is zero when airflow is indicated on the LCD display of the transmitter.	The Low Limit airflow cutoff value is above the actual airflow reading.	Decrease the Low Limit airflow cutoff value in the Setup menu until it is below the actual airflow reading.
The status point from the transmitter has a Trouble value.	The sensor detection system has detected one or more malfunctioning or missing sensors.	Check sensor probe cable connections. If sensor probe connections look OK and match the number of sensor probes indicated on each probe's hang tag.
	A probe with 5 or more sensors has been connected to a 'Type B' transmitter with 4 receptacles.	Probes with 5 or more sensors are shipped with and require a 'Type A' transmitter with 2 receptacles.
There is no value for the differential pressure point	Differential pressure is only available from transmitters that have a Bi-directional Bleed Airflow Sensors connected.	If a differential pressure measurement is required, contact your local Daikin Applied Representative about a Bi-directional Bleed Airflow Sensor.

Figure 45: Optional Outdoor Air Monitor – Changing the Units

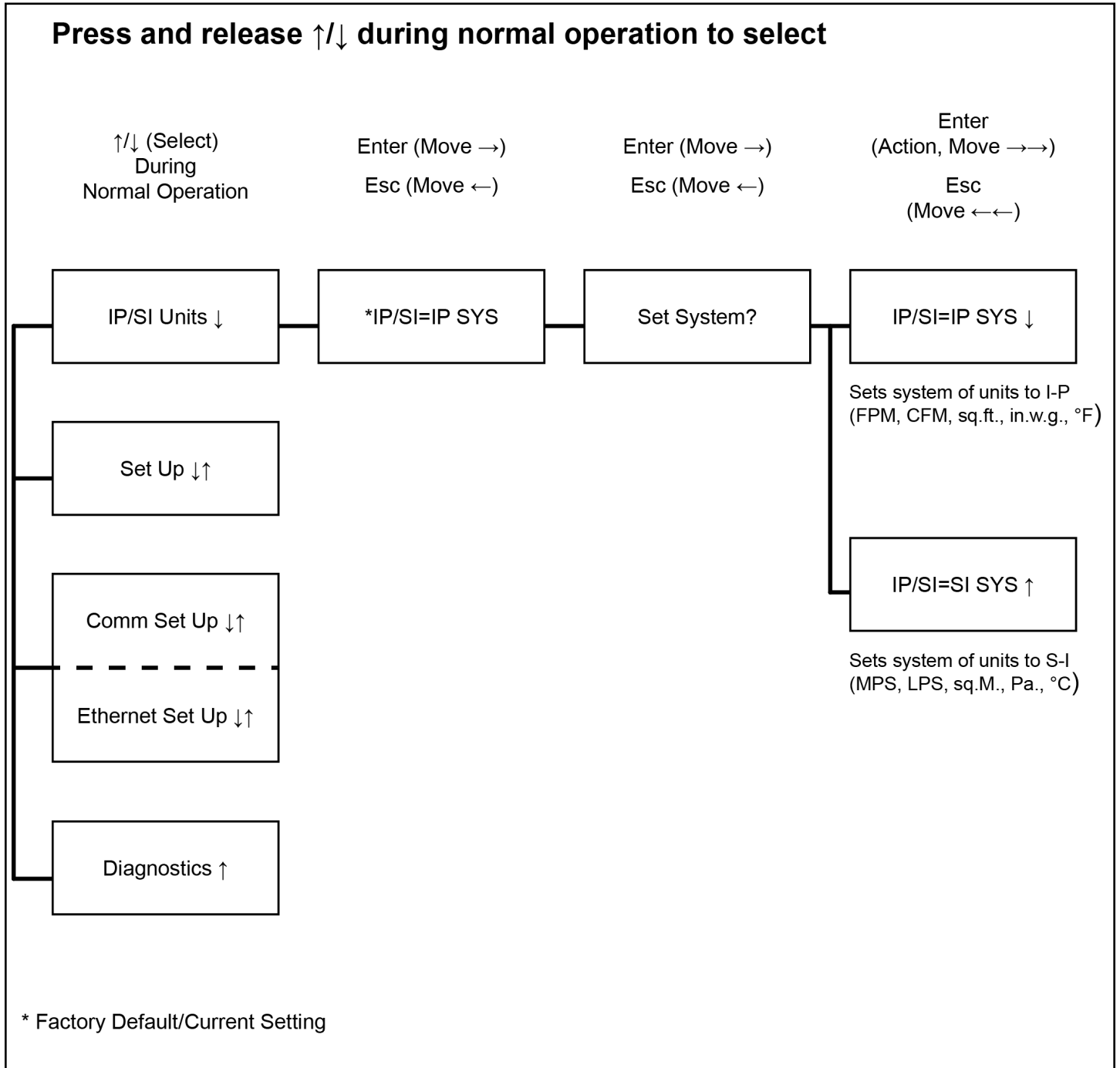
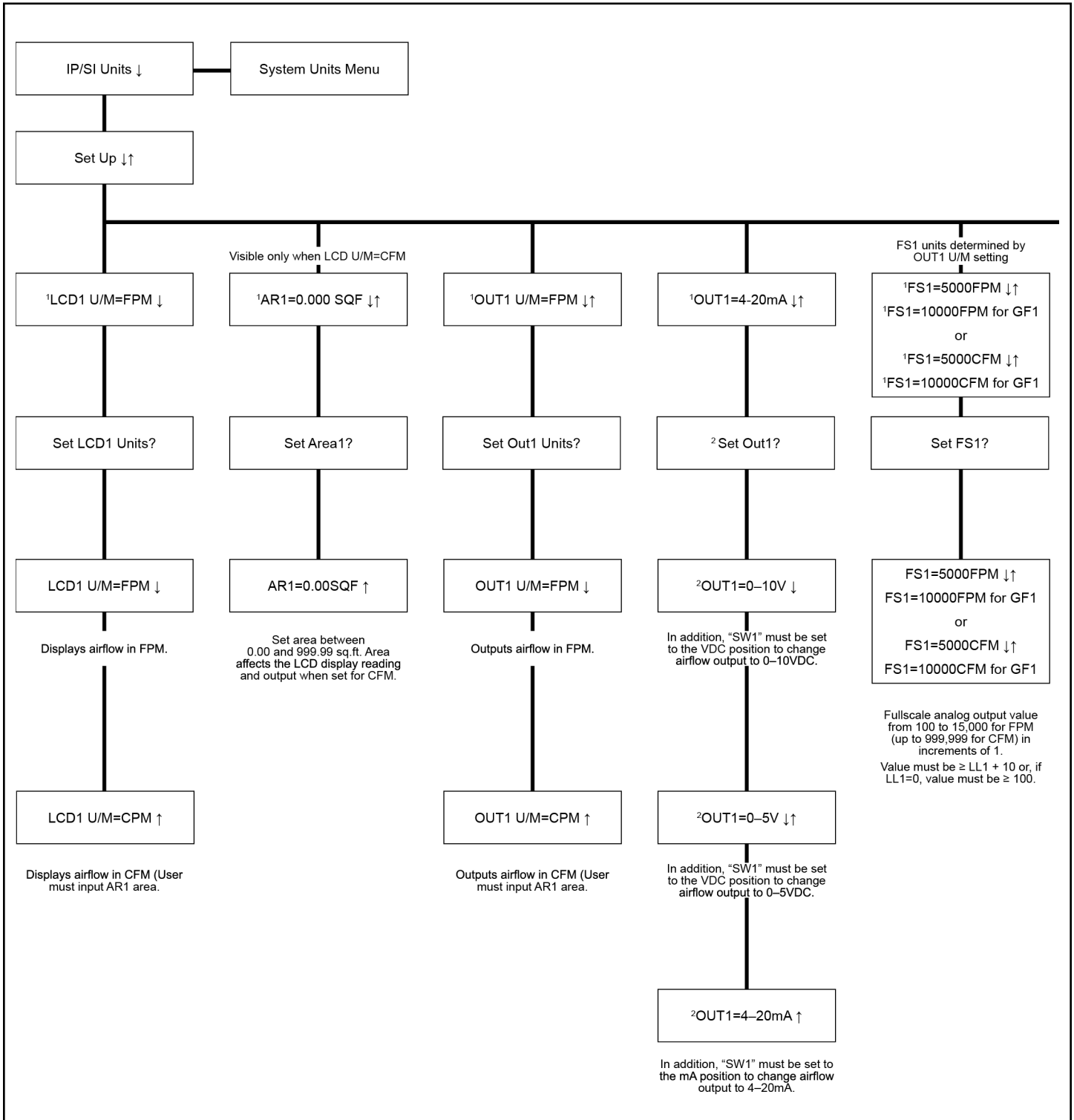
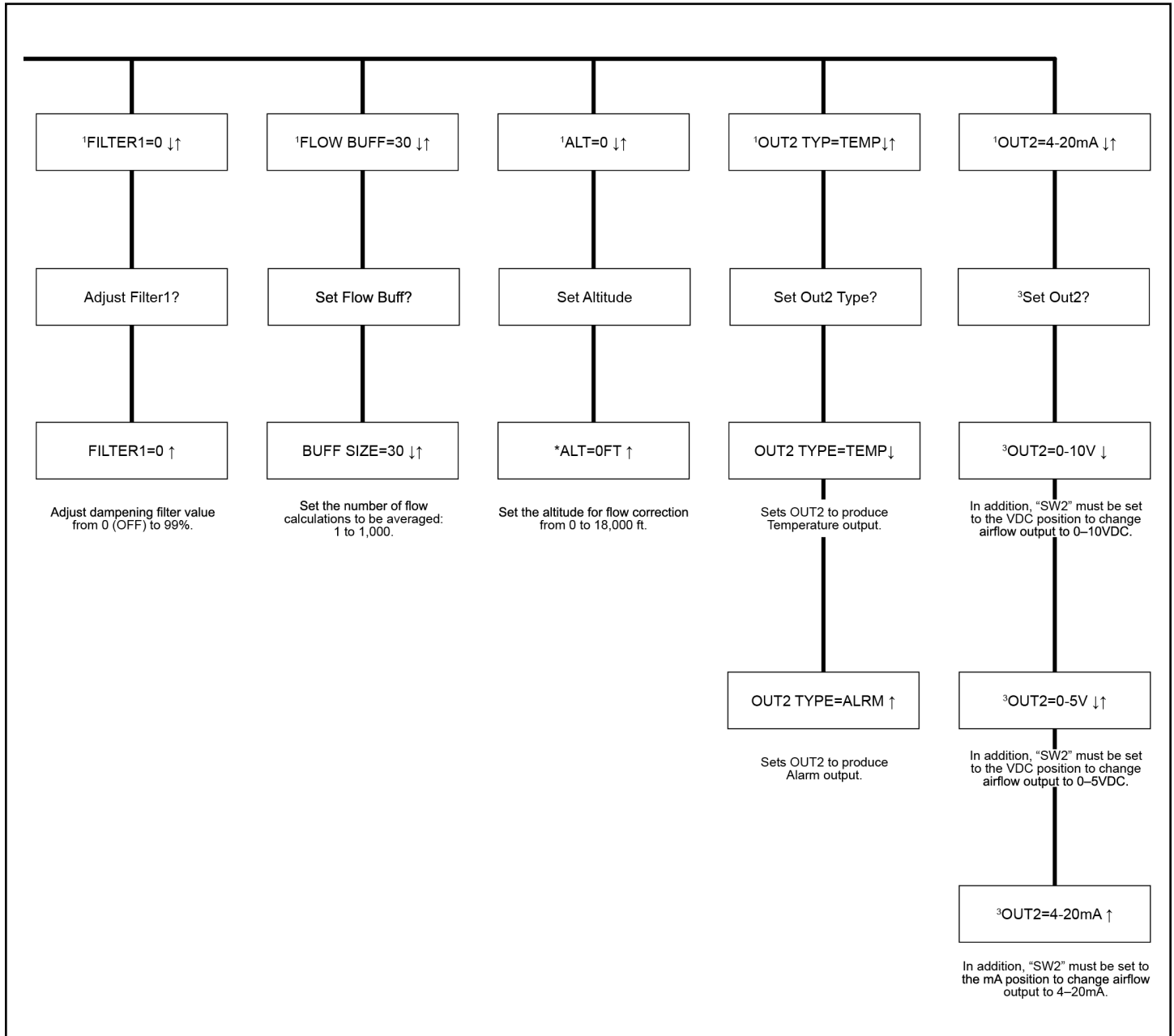

Figure 46: Optional Outdoor Air Monitor – Set Up Menu (1)



**NOTE:** <sup>1</sup>Factory default/current setting  
<sup>2</sup>If a selection is made that requires SW1 to be set, the LCD displays "Set SW1 on Board".  
<sup>3</sup>If a selection is made that requires SW2 to be set, the LCD displays "Set SW2 on Board".

Figure 47: Optional Outdoor Air Monitor – Set Up Menu (2)



**NOTE:** <sup>1</sup>Factory default/current setting  
<sup>2</sup>If a selection is made that requires SW1 to be set, the LCD displays "Set SW1 on Board".  
<sup>3</sup>If a selection is made that requires SW2 to be set, the LCD displays "Set SW2 on Board".

## Unit Options

### Economizer Enthalpy Control

The economizer can be ordered with the optional differential enthalpy control. With this option a solid-state humidity and temperature sensing device is located in the return and outdoor airstreams. These devices are labeled RAE and OAE respectively. When the outdoor enthalpy is lower than the return air enthalpy, the economizer operation will be initiated. If the outdoor air enthalpy is higher than the return air, the outdoor air damper position will be at the minimum setpoint. See the MicroTech unit controller for further information on the economizer operation.

### External Time Clock

You can use an external time clock as an alternative to (or in addition to) the MicroTech controller's internal scheduling function. The external timing mechanism is set up to open and close the circuit between field terminals 101 and 102. When the circuit is open, power is not supplied to binary input ID1. This is the normal condition where the controller follows the programmable internal schedule. When the circuit is closed, power is fed to ID1. The MicroTech controller responds by placing the unit in the occupied mode, overriding any set internal schedule.

### Exhaust Fan Option

Economizer units may include exhaust fan options. For units with CAV applications, the exhaust fans can be ordered as staged control or they may be ordered with building pressure control. The building pressure control option has a VFD that runs the exhaust fan motors and is controlled by the static pressure sensor number 2 (SPS2). Refer to the unit controller manual for setting up the unit controller with these two options. The units are only available with building pressure control on VAV units.

The exhaust fan motors are permanently lubricated and do not require any additional periodic lubrication.

**Figure 48: Pressure Tubing Diagram**

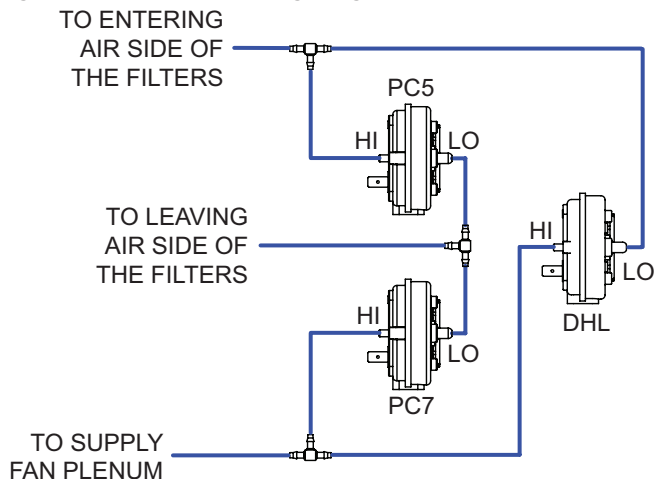

### Proof-of-Airflow and Dirty Filter Switch

The proof-of-airflow switch (PC7) and the dirty filter switch (PC5) are supplied on all CAV units. The tubing is installed to the switches per Figure 48. The proof of airflow switches senses the pressure difference between the positive pressure in the supply air fan compartment and the suction pressure on the leaving air side of the filters. The differential pressure is factory set at 0.25" for this switch. The dirty filter switch senses the pressure difference across the filter; from the entering air side of the filter to the leaving air side of the filters. The switch is factory set at 1.0". When the pressure difference across the filters is sensed at this value, the dirty filter alarm will appear on the DDC controller.

All VAV units also have the PC7 and PC5 switches as standard (see Figure 40). These switches are tied into the Duct High Limit switch (DHL) as shown in Figure 48.

The DHL is factory set at 4.0". When this differential pressure is sensed the normally closed contacts will open on the switch giving the DHL alarm at the unit controller.

### Duct High Pressure Limit

The duct high pressure limit control (DHL) is provided on all VAV units. The DHL protects the duct work, terminal boxes, and the unit from over pressurization, which could be caused by, for example, tripped fire dampers or control failure.

The DHL control opens when the discharge plenum pressure rises to 3.5" WC (872 Pa). This setting should be correct for most applications and should not be adjusted.

If the DHL switch opens, digital input ID9 on the Unit Control Board will be de-energized. The MicroTech controller then shuts down the unit and enters the Off-Alarm state. The alarm must be manually cleared before the unit can start again. Refer to the operation manual supplied with your unit for more information on clearing alarms (refer to the unit controller manual).

### Convenience Receptacle (Field Powered)

A Ground Fault Circuit Interrupter (GFCI) convenience receptacle is provided in the main control box on all units. To use this receptacle, connect a separate field-supplied 115 V power wiring circuit to the outlet.

Figure 49: Unit Powered GFCI Receptacle Schematic (Typical)

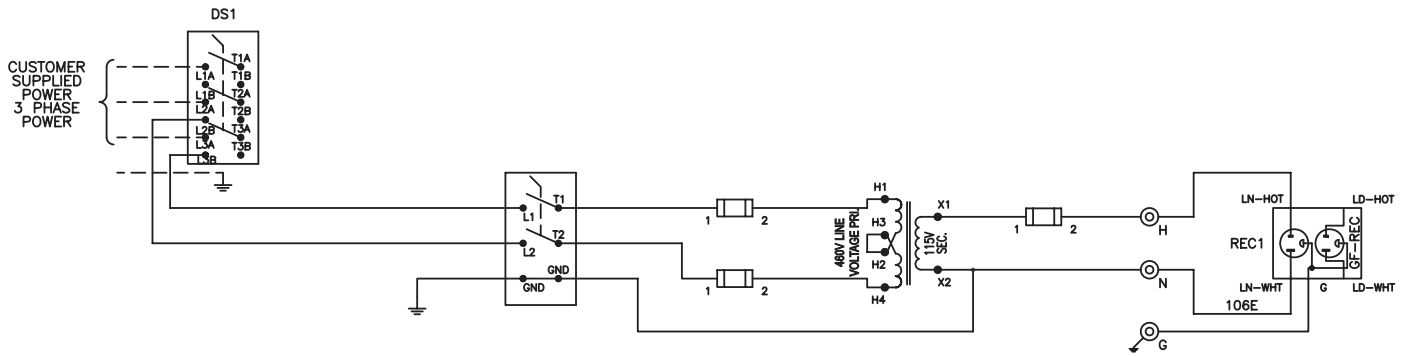

### Convenience Receptacle (Unit Powered)

A Ground Fault Circuit Interrupter (GFCI) convenience receptacle is provided in the main control box on all units. The receptacle shall be powered by a factory installed and wired 120V, 20 amp power supply. The power supply shall be wired to the line side of the unit's main disconnect, so the receptacle is powered when the main unit disconnect is off. This option shall include a GFI receptacle, transformer, and a branch circuit disconnect. The electrical circuit shall be complete with primary and secondary overload protection. See [Figure 49](#) for a branch circuit diagram.

# Wiring Diagrams

Figure 50: Example Diagram (1)

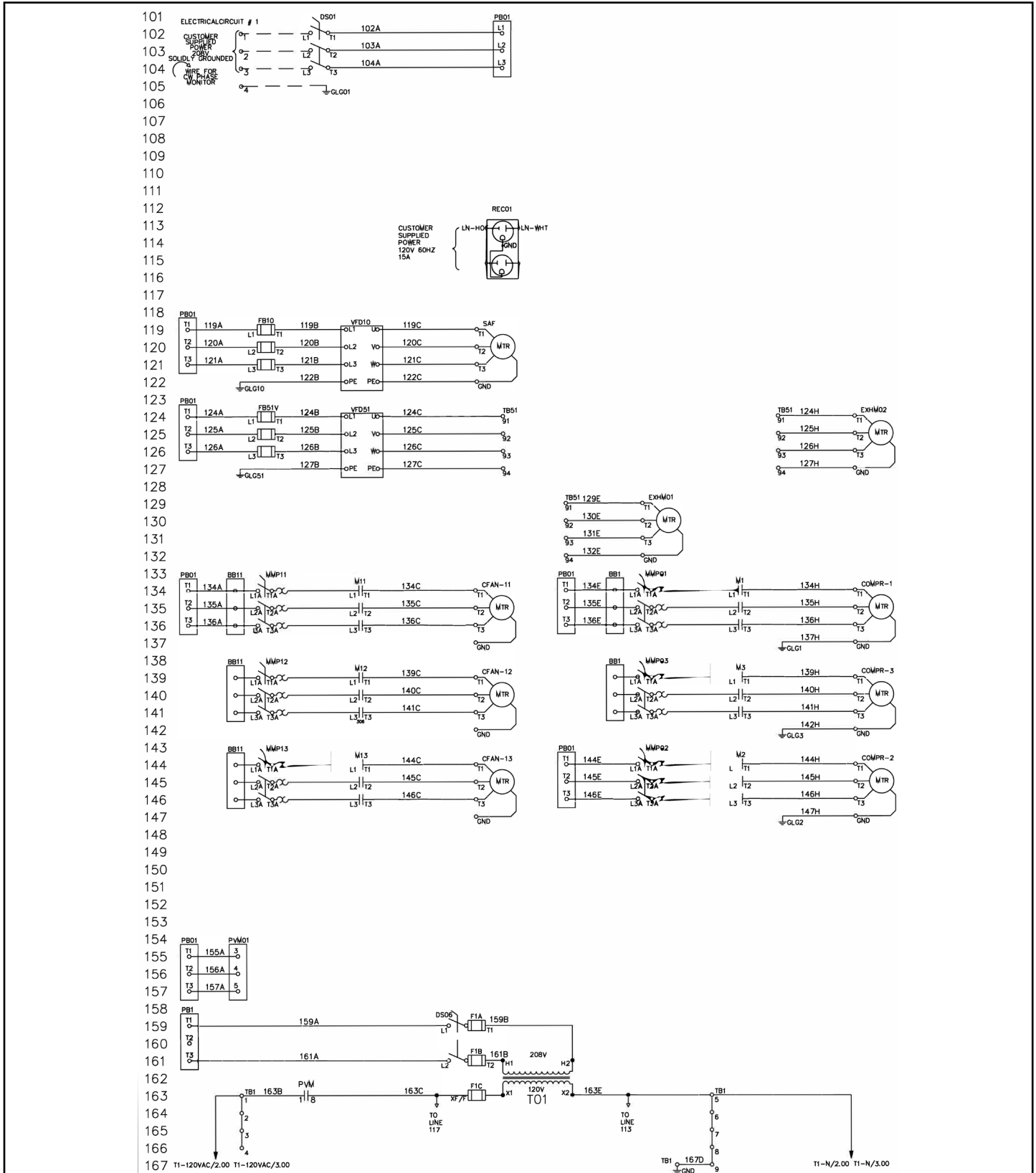



Figure 52: Example Diagram (3)

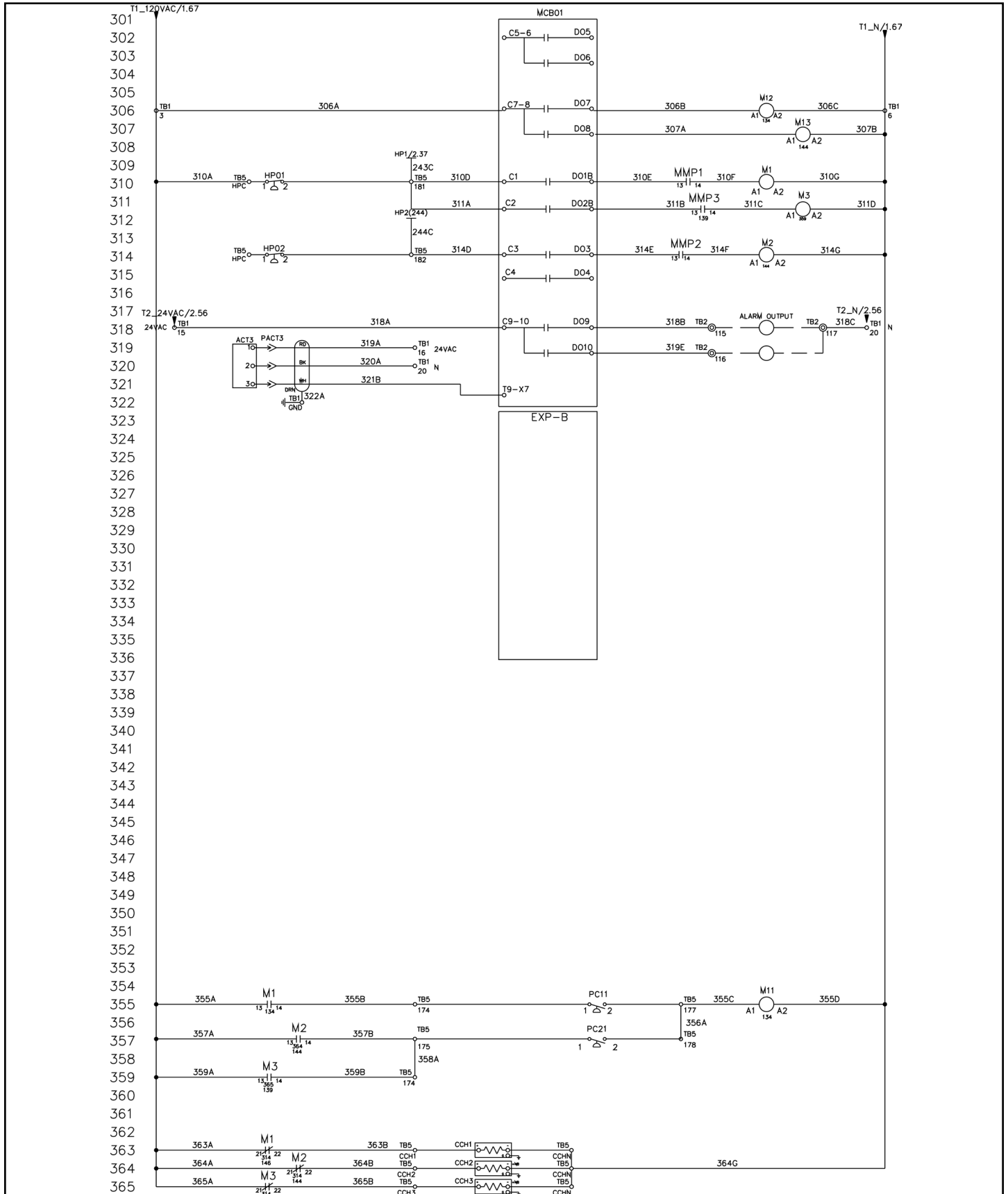
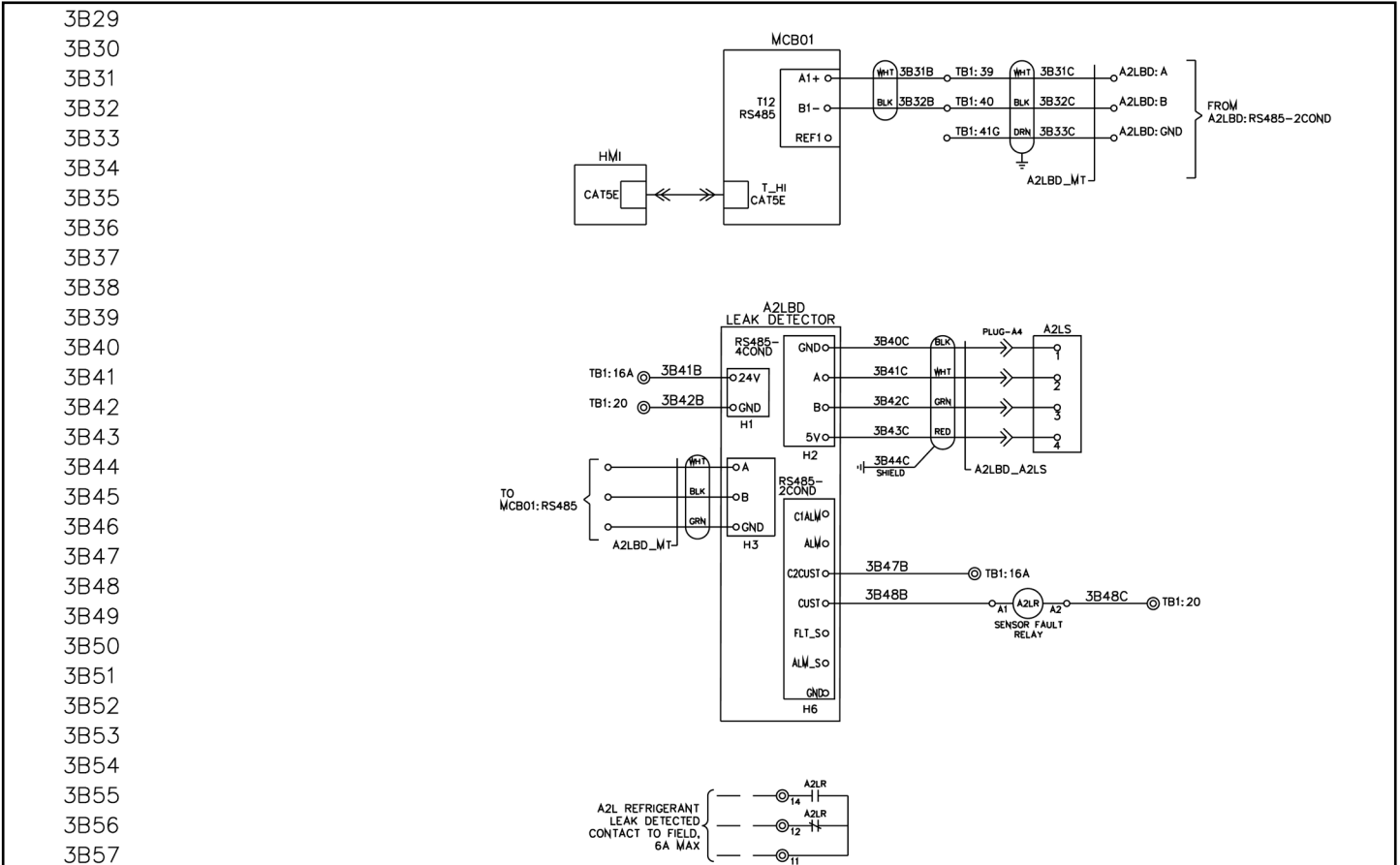

Figure 53: Example Diagram (4)



# Sequence of Operation

## Operating States

The transition from any operating state to another is graphically represented in Figure 54.

Figure 54: State Diagram

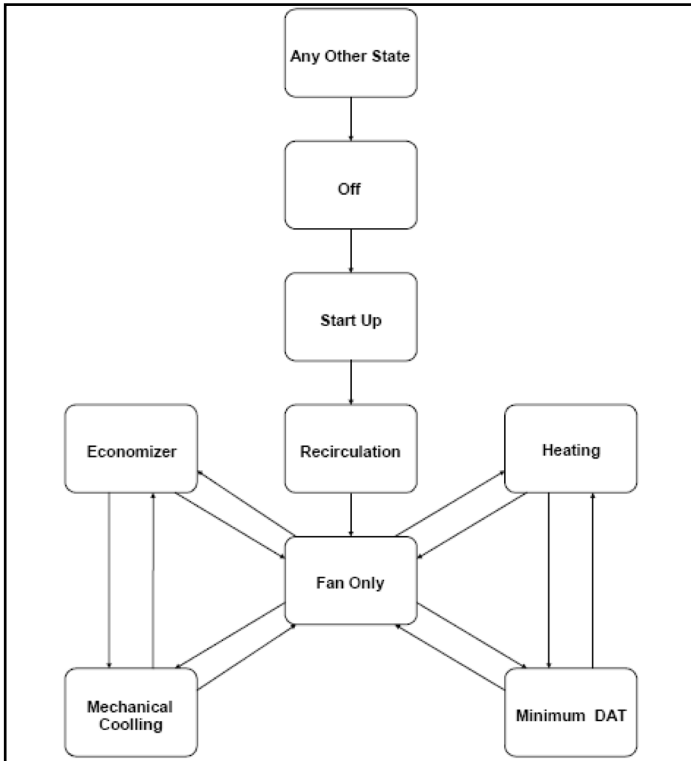

## OFF Operating State

In the Off operating state the fans are off, the outside air dampers are closed and any VFD's are driven to 0%. Cooling and heating are disabled. The unit is in the off state when it is not enabled, or when it is in the unoccupied mode with no call for unoccupied operation.

## Start Up Operating State

When a unit is commanded to start it will always enter the Startup operating state from the OFF operating state. The unit remains in the Startup operating state for an adjustable time period (default 180 seconds) before entering the Recirculating operating state.

During the Start up operating state the fans remain OFF, the outdoor air dampers are driven closed, and VFD's remain at 0%. Cooling and heating are disabled, except for 100% OA heating start sequences.

## Recirculating Operating State

Units with return air always enter the Recirculating operating state after the completion of the Startup operating state. In the Recirculating operating state fans are started and operate while the outdoor air dampers remain closed. This allows temperature conditions throughout the unit and space to equalize before temperature control begins. Cooling and heating remain disabled. The unit remains in the Recirculating operating state until the Recirculate State Timer (default 180 seconds) expires.

100% outdoor air units do not transition through the Recirculating operating state.

## Fan Only

The unit enters the Fan Only operating state after the recirculation timer expires. Units configured for 100% outside air operation will transition directly from the Start up operating state into the Fan Only operating state. Once entering the Fan Only state of operation the unit will then, based on sensor inputs transition into any of the 4 remaining states of operation - heating, cooling, economizer, or minimum discharge air heating.

## Min DAT

If heating is enabled and there is no heating load (normally Fan Only operating state), the controller activates the units heating equipment as required to prevent the discharge air temperature from becoming too cool if the Min DAT Control Flag is set to yes via the Heating menu (Commission Unit/Heating/MinDAT Ctrl). The unit enters the Min DAT operating state during occupied operation when neither cooling nor heating is required based on the heat/cool changeover function but the discharge temperature falls below a minimum discharge temperature limit. If the discharge air temperature falls below the this minimum discharge temperature limit by more than half the discharge heating deadband, the unit operating state changes from Fan Only to Min DAT. The unit transitions out of the Min DAT operating state once the discharge air temperature is above minimum discharge temperature limit and the heating capacity has been at its minimum position for the duration of the heating stage timer.

**NOTE:** On VAV or CAV discharge control units, the DAT cooling setpoint parameter in the Cooling menu acts as the minimum discharge temperature limit. On CAV zone control units the Min DAT Limit parameter in the Heating menu acts as the minimum discharge temperature limit.

## Heating

The unit enters the Heating operating state when the control temperature falls below the Occupied or Unoccupied Heating Setpoint by more than ½ the occupied or unoccupied heating deadband. During the Heating operating state, the outdoor air dampers are either 100% open if the unit is a 100% outdoor air unit or controlled to the minimum outside air position. Cooling is disabled.

## Mechanical Cooling

### Constant Volume (Space Comfort Controller)

The control temperature for a CAV unit is typically the space temperature. A space temperature sensor must be field installed into the occupied space and connected to the unit controller.

The unit goes into the cooling mode of operation when the control temperature (space temperature) is above the cooling setpoint by more than  $\frac{1}{2}$  the deadband.

**Example** – the cooling setpoint is set to 70.0°F (21.1°C) and the deadband is 1.0°F (0.56°C), the unit will not go into the cooling mode of operation until the space sensor reaches 70.6°F (21.4°C).

When this takes place, the cooling mode of operation will begin and the 1st stage of compressor operation will start.

The unit controller will turn on the next stage of compressor operation, or turn off a stage of compressor operation, to maintain the cooling setpoint temperature within the deadband. When a compressor stage turns on, the next compressor stage, up or down, will not take place for the next 4 minutes. This “4 minutes” is called the stage time. Reference the “Cooling Setup” menu for the adjustable stage time value.

When a cooling stage is initiated no further operation will take place within the stage timer limit. In the above example, the unit will stage down or turn off the cooling mode of operation when the cooling setpoint reaches 69.4°F (20.8°C).

### Variable Air Volume (Discharge Air Controller)

The unit's cooling mode of operation is controlled by the control temperature, the change-over temperature, and the discharge air temperature. The unit goes into the cooling mode of operation by analyzing the control temperature. The control temperature for a VAV system is the return temperature.

The unit goes into the cooling mode of operation when the control temperature (return temperature) is above the changeover setpoint by more than  $\frac{1}{2}$  the deadband.

**Example** – If the change over temperature is 70.0°F (21.1°C) and the deadband is 1.0°F (0.56°C), the unit will not go into the cooling mode of operation until the return temperature reaches 70.6°F (21.4°C).

When this takes place, the cooling mode of operation will begin and the 1st stage of compressor operation will start.

The unit controller will turn on the next stage of compressor operation, or turn off a stage of compressor operation, to maintain the discharge air temperature setpoint within the deadband. When a compressor stage turns on, the next compressor stage up or down will not take place for the next 4 minutes. This “4 minutes” is called the stage timer.

When a cooling stage is initiated no further operation will take place within the stage timer limit. Reference the Cooling Setup menu for the adjustable stage time value. In the above example, the unit will stage down or turn off the cooling mode of operation when the return temperature reaches 69.4°F (20.8°C).

## Economizer

If the unit is equipped with a 0-100% modulating economizer (waterside or airside) and the conditions are suitable for free cooling, the unit attempts to satisfy the cooling load by using either outdoor air or the waterside economizer before using mechanical cooling.

If the unit is configured for Zone Temperature Control the transition to economizer operation will occur if all the following are true:

- The control temperature rises above the occupied or unoccupied cooling setpoint by more than half the occupied or unoccupied cooling high deadband
- The discharge air temperature is greater than the Min DAT limit by more than half the DAT
- Heating deadband. This will prevent more cold air from being brought in when the DAT is already cold
- The economizer operation is not disabled

If the unit is configured for Discharge Air Temperature Control the transition to Mechanical cooling will occur if all the following are true:

- The control temperature rises above the occupied or unoccupied cooling setpoint by more than half the occupied or unoccupied cooling deadband
- The discharge air temperature is greater than the DAT cooling setpoint
- The Ambient air temperature is below the Change Over Temperature set point, (Chgover temp) Default of 70° F (21°C) Range: 0 to 100°F (-18 to 38°C).
- If the system incorporates an enthalpy control the control does not sense the enthalpy of the outside air is too high.

## Check, Test, and Start

### WARNING

**Electric shock and moving machinery hazard. Can cause severe equipment damage, personal injury, or death.**

Disconnect and tag out all electrical power before servicing this equipment.

All start-up and service work must be performed only by trained, experienced technicians familiar with the hazards of working on this type of equipment

Read and follow the MicroTech unit controller operation manual before operating or servicing.

Bond the equipment frame to the building electrical ground through grounding terminal or other approved means.

### WARNING

**Hazardous voltage. May cause severe injury or death.**  
Disconnect electric power before servicing equipment.

## Pre-Start of Unit

All units are completely run tested at the factory to promote proper operation in the field. However, to ensure proper operation once the unit is installed, the following check, test, and start procedures must be performed to properly start the unit. To obtain full warranty coverage, complete and sign the check, test, and start form supplied with the unit and return it to Daikin Applied.

A representative of the owner or the operator of the equipment should be present during start-up to receive instructions in the operation, care, and maintenance of the unit.

## Servicing Control Panel Components

### Before Start-Up

1. Remove shipping bolt form fan spring.
2. Verify that the unit is completely and properly installed with ductwork connected.
3. Verify that all construction debris is removed, and that the filters are clean.
4. Verify that all electrical work is complete and properly terminated.
5. Verify that all electrical connections in the unit control panel are tight, and that the proper voltage is connected.
6. Verify all nameplate electrical data is compatible with the power supply.
7. Verify the phase voltage imbalance is no greater than 2%.
8. Verify that gas piping is complete and leak tight.
9. Verify that the shutoff cock is installed ahead of the furnace, and that all air has been bled from the gas lines.
10. Verify installation of gas flue and outside air vents.
11. Manually rotate all fans and verify that they rotate freely.
12. Verify that the belts are tight and the sheaves are aligned.
13. Verify that all setscrews and fasteners on the fan assemblies are still tight. See "[Setscrews](#)" on page 79.
14. Verify that the evaporator condensate drain is trapped and that the drain pan is level.
15. If unit is curb mounted, verify that the curb is properly flashed to prevent water leakage.
16. Review the equipment and service literature, the sequences of operation, and the wiring diagrams to become familiar with the functions and purposes of the controls and devices.
17. Determine which optional controls are included with the unit.
18. Inspect the outside and inside of the unit for any signs of damage or rough handling. Excessive air leakage would be one possible, unacceptable consequence. If any problems are found, contact the local Daikin Applied representative for instructions.

## Power-Up

1. Close the unit disconnect switch.
2. Power should now be supplied to the control panel.

## Fan Start-Up

1. Remove shipping bolt from fan spring if this has not already been done.
2. Verify fan spring adjustment and that the fan assembly is level. Adjust as necessary.
3. Verify all duct isolation dampers are open.
4. Place the unit into the "Fan Only" mode through the keypad.
5. The controller should enter the "Startup Initial" operating state. If the fan does not run, check the manual motor protectors or that the circuit breakers have not tripped.
6. Verify the rotation is correct.

## Economizer Start-Up

1. Check whether the outdoor air is suitable for free cooling.
2. At the keypad, set the cooling setpoint low enough so the controller calls for cooling.
3. Place the unit into cooling mode through the keypad menu.
4. Observe the outdoor air dampers:
  - a. If the outdoor enthalpy is low, the control algorithm should start to modulate the dampers open to maintain the discharge air setpoint.
  - b. If the outdoor enthalpy is high, the dampers should maintain their minimum position.

**NOTE:** It may not be possible to check the economizer operation in both low and high enthalpy states on the same day. If this is the case, repeat this procedure on another day when the opposite outdoor air enthalpy conditions exist.

## Compressor Start-Up

### CAUTION

**Low ambient temperature hazard. Can cause compressor damage.** Do not attempt to start up and check out the refrigeration system when the outdoor air temperature is below 20°F (-6.7°C).

With the supply fan operational, prepare for compressor operation.

1. Inspect all refrigerant piping and look for leaks by looking for refrigerant oil residue. If any problem is found, reclaim any remaining refrigerant, fix the problem and then add the circuit's nameplate charge by weight before proceeding.
2. Connect service gauges and verify that the unit has not lost its refrigerant charge.
3. Verify that the crankcase heaters are operating. These should operate for at least 24 hours before starting the compressors.

4. Verify that the condenser fan blades are positioned properly (see Figure 55) and that the screws are tight. The fan blade must be correctly positioned within its orifice for proper airflow across the condenser coils.
5. Check the fan rotation.

**Figure 55: Condenser Fan Blade Positioning**

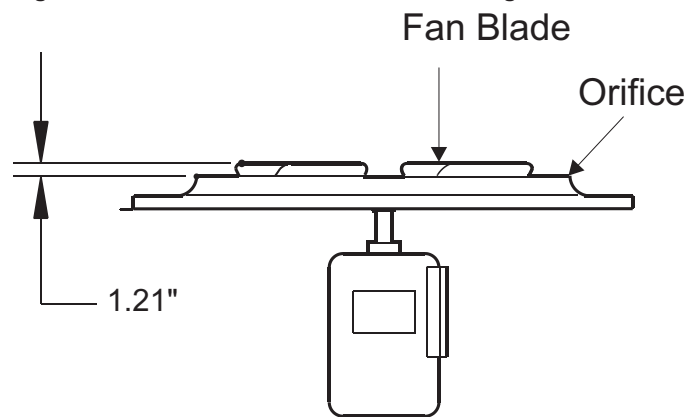

## Scroll Compressor Rotational Direction

Scroll compressors only compress in one rotational direction. Three-phase compressors rotate in either direction depending upon phasing of the power to L1, L2, and L3. Since there is a 50/50 chance of connecting power to cause rotation in the reverse direction, verify that the compressor rotates in the proper direction after the system is installed. If the compressor is rotating properly, suction pressure drops and discharge pressure rises when the compressor is energized. If the compressor is rotating in reverse, the sound level is louder and current draw is reduced substantially. After several minutes of operation, the compressor's internal protector trips.

All three-phase compressors are wired the same internally. Therefore, once the correct phasing is determined for a specific system or installation, connecting properly phased power leads to the same terminals should maintain proper rotation direction.

### **Perform the Following Procedure:**

1. At the keypad, set the cooling setpoint low enough so that the controller will call for cooling.
2. Verify that compressor #1 starts. If the compressor motor hums but does not run, verify that it is getting three-phase power.
3. The compressor should operate continuously while there is a call for cooling. If the compressor cycles on and off on its low pressure switch, perform the following:
  - a. Verify that the circuit is not short of refrigerant.
  - b. Check for low airflow across the evaporator coil.
  - c. Check for clogged filters.
  - d. Check for restricted ductwork.
  - e. Check for very low temperature return air entering the unit.

- f. Verify that the liquid line components, expansion valve, and distributor tubes are feeding the evaporator coil.
  - g. Verify that all air handling section panels are closed.
4. Verify that the condenser fans are cycling and rotating properly (blowing air upward). When the compressor starts, at least one condenser fan should also start.
  5. Check the oil level in the compressor sightglass. If low oil is observed, it is possible that liquid refrigerant is returning to the compressor. Check the suction superheat, see "Expansion Valve Superheat Adjustment" below. It should be between 10°F (5.5°C) and 13°F (7.2°C). See "Expansion Valve Superheat Adjustment" below.
  6. Verify that the condenser refrigerant subcooling at full capacity is between 13°F (7.2°C) and 20°F (11.1°C).

### Checking Subcooling

Following are recommendations for checking subcooling:

1. Run unit until it reaches steady state. Close the unit section doors. Running the unit with its doors open will affect system operation.
2. Measure the discharge gas pressure at the compressor discharge gauge port with an accurate gauge. Use this pressure to determine the saturation temperature of the refrigerant.
3. Measure liquid temperature accurately by attaching a thermocouple to the liquid line tube leaving the condenser coil. Insulate the tube and thermocouple for more accurate results.
4. Subtract the measured liquid temperature from the saturation temperature to determine the subcooling.
5. As a general rule, high subcooling indicates that the circuit is low on charge. Low subcooling generally indicates that the circuit has too much charge.

### NOTICE

Venting refrigerant to atmosphere is not allowed per most local laws and/or codes.

## Expansion Valve Superheat Adjustment

It is very important that the expansion valve superheat setting be adjusted to be between 10°F (5.5°C) and 13°F (7.2°C). Insufficient superheat will cause liquid floodback to the compressor which may result in slugging. Excessive superheat will reduce system capacity and shorten compressor life.

Turn the adjustment stem clockwise to increase superheat. Not exceeding one turn, adjust the stem and then observe the superheat. Allow up to 30 minutes for the system to rebalance at the final superheat setting.

### Checking Superheat

Following are recommendations for checking superheat:

1. Close the unit section doors. Running the unit with its doors open will affect expansion valve and system operation considerably.
2. Check the pressure and temperature at the suction gauge port.

## Sheave Alignment

1. Verify both motor and fan sheaves are in alignment and the shafts are parallel. The center line of the motor sheave must be in line with the center line of the fan sheave. See [Figure 56](#).
2. Verify that all setscrews are torqued to the values shown in [Table 22 on page 79](#) before starting drive. Check setscrew torque and belt tension after 24 hours of service.

**Figure 56: Sheave Alignment (Adjustable Shown)**

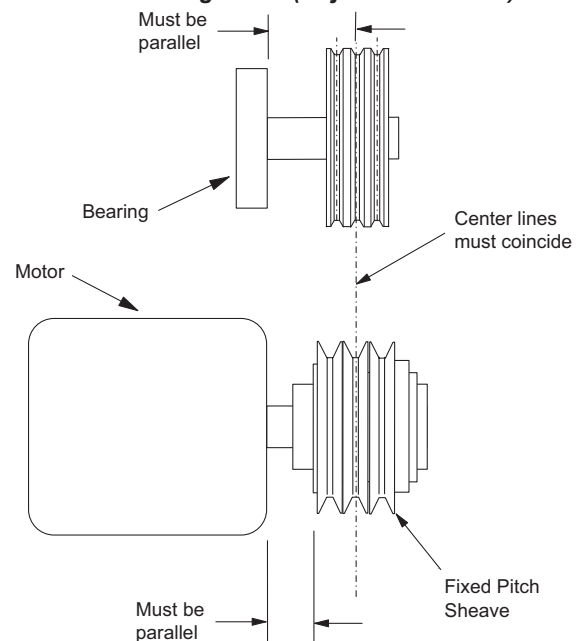

## Drive Belt Tension Adjustment

1. The ideal tension is the lowest tension at which the belt will not slip under peak load conditions. Over tensioning shortens belt and bearing life.
2. Check tension frequently during the first 24–48 hours of operation.
3. Keep belts free from foreign material which may cause slippage.
4. Make V-drive inspection on a periodic basis. Adjust tension if the belt is slipping. Do not apply belt dressing. This may damage the belt and cause early failure.

## Air Balancing

The following should be performed by a qualified air balancing technician:

1. Check the operating balance with the economizer dampers positioned for both full outdoor air and minimum outdoor air.
2. Verify that the total airflow will never be less than that required for operation of the gas furnace.
3. When the final drive adjustments or changes are complete, check the current draw of the supply fan motors. The amperage must not exceed the service factor stamped on the motor nameplate.

### **WARNING**

**Moving machinery hazard. Can cause severe personal injury or death.** Do not use a mechanically driven tachometer to measure the speed return fans on this fan arrangement. Use a strobe tachometer.

**Rotating parts can cause severe personal injury or death.** Replace all belt/fan guards that are removed for service.

## Diameter Seal Adjustment

1. Loosen diameter seal adjusting screws. See [Figure 57](#).
2. Move adjustable diameter seals away from wheel.
3. Using a ¼ inch feeler gauge, adjust the diameter against the wheel. See [Figure 57](#).
4. Tighten diameter seal adjusting screws.
5. Apply power per the start up procedure.

### **WARNING**

Keep hands away from rotating wheel! Contact with rotating wheel can cause physical injury.

**Figure 57: Energy Recovery Wheel**

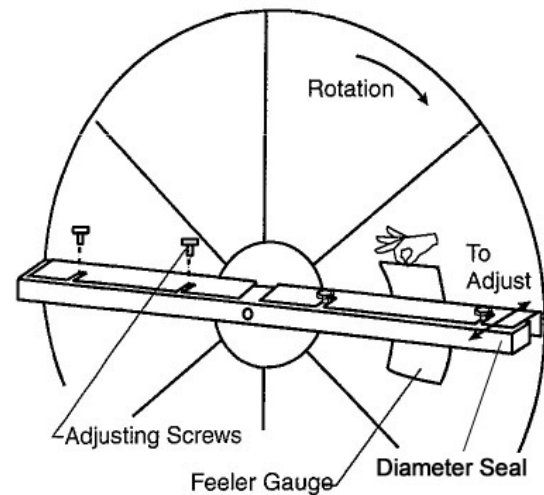

## Energy Recovery Wheel

### Prestartup Checks

1. By hand, turn wheel clockwise (as viewed from the pulley side) to verify wheel turns freely through 360° rotation.
2. During rotation confirm wheel segments are fully engaged in the wheel frame and segment retainers are completely fastened
3. With hands and objects away from moving parts, apply power and confirm wheel rotation. Wheel rotates clockwise as viewed from the pulley side.
4. If wheel has difficulty starting, disconnect power and inspect for excessive interference between the wheel surface and each of the (4) diameter seals.

# Final Control Settings

## Controller Settings for Normal Operation

When all start-up procedures are completed, set the controls and program the MicroTech controller for normal operation. Use the following list as a guide; some items may not apply to your unit.



1. Set the heating and cooling parameters as required for normal unit operation:
  - a. Temperature \ Zone Cooling \
  - b. Temperature \ Zone Heating \
  - c. Temperature \ Discharge Cooling \
2. Set the low ambient compressor lockout setpoint as required. Do not set it below 20°F (-6.7°C).
3. Set the high ambient heat lockout temperature setpoint.
4. Set the alarm limits as required.
5. Set the duct static pressure control parameters as required.
6. Set the building static pressure control parameters as required.
7. Set the economizer control parameters as required.
8. Set the date and time in keypad menu.
9. Set the operating schedule as required using keypad menus.

**NOTE:** Unit operation may also be controlled by the building automation system.

## Maintaining Control Parameter Records

Daikin Applied recommends that the MicroTech controller's setpoints and parameters be recorded and saved for future reference. If the microprocessor control board requires replacement, this record facilitates entering the unit's proper data.

## R-32 Guidelines

 <b>WARNING</b>	
 <b>A2L</b>	<p>This unit contains R-32, a class A2L refrigerant that is flammable. This unit should only be installed, serviced, repaired, and disposed of by qualified personnel licensed or certified in their jurisdiction to work with R-32 refrigerant. Installation and maintenance must be done in accordance with this manual. Improper handling of this equipment can cause personal injury or equipment damage.</p>
<p>Be aware that R-32 refrigerant may not contain an odor. Place in a well ventilated area to prevent accumulation of refrigerant. Excessive refrigerant leaks, in the event of an accident in a closed ambient space, can lead to oxygen deficiency.</p>	
<p>Do not pierce or burn this unit.</p>	
<p>Never use an open flame during service or repair. Never store in a room with continuously operating ignition sources (for example: open flames, an operating gas appliance, or an operating electric heater), where there is ignitable dust suspension in the air, or where volatile flammables such as thinner or gasoline are handled.</p>	
<p>Only use pipes, nuts, and tools intended for exclusive use with R-32 refrigerant in compliance with national codes (ASHRAE15 or IRC).</p>	
<p>Do not mix air or gas other than R-32 in the refrigerant system. If air enters the refrigerant system, an excessively high pressure results, which may cause equipment damage or injury.</p>	
<p>Do not use means to accelerate the defrosting process or to clean, other than those recommended by the manufacturer.</p>	

Maintaining and servicing R-32 refrigerant should only be performed as recommended by this manual and by personnel licensed or certified in their jurisdiction to handle A2L refrigerants under a controlled procedure. Dismantling the unit and treatment of the refrigerant, oil, and additional parts must be done in accordance with the relevant local, state, and national regulations.

Only use tools meant for use on R-32 refrigerant, such as a gauge manifold, charge hose, gas leak detector, reverse flow check valve, refrigerant charge base, vacuum gauge, or refrigerant recovery equipment.

## Performing Service

### *Remove Ignition Sources*

Always perform a safety check of the area to ensure the risk of ignition is minimized before servicing the unit.

### *Personnel Awareness*

Inform maintenance staff and others working in the local area of the nature of work being carried out. Only personnel attending to the refrigerant system should be present.

### *Check for Presence of Airborne Refrigerant*

Check the area with an appropriate refrigerant detector prior to and during work to ensure all personnel are aware of potentially toxic or flammable gases in the air. Ensure that the leak detection equipment being used is suitable for use with all applicable refrigerants; i.e. non-sparking, adequately sealed or intrinsically safe.

### *Presence of fire extinguisher*

If any hot work is to be conducted on the refrigerating equipment or any associated parts, appropriate fire extinguishing equipment should be available to hand. Have a dry powder or CO<sub>2</sub> fire extinguisher adjacent to the charging area.

### *No Ignition Sources*

No person carrying out work in relation to a REFRIGERATING SYSTEM which involves exposing any pipe work shall use any sources of ignition in such a manner that it may lead to the risk of fire or explosion. All possible ignition sources, including cigarette smoking, should be kept sufficiently far away from the site of installation, repairing, removing and disposal, during which refrigerant can possibly be released to the surrounding space. Prior to work taking place, the area around the equipment is to be surveyed to make sure that there are no flammable hazards or ignition risks. "No Smoking" signs shall be displayed.

### *Ventilated area*

Ensure that the area is in the open or that it is adequately ventilated before breaking into the system or conducting any hot work. A degree of ventilation shall continue during the period that the work is carried out.

### *Checks to the refrigerating equipment*

Where electrical components are being changed, they shall be fit for the purpose and to the correct specification. At all times the manufacturer's maintenance and service guidelines shall be followed. If in doubt, consult the manufacturer's technical department for assistance.

The following checks shall be applied to installations using **FLAMMABLE REFRIGERANTS**:

- The actual REFRIGERANT CHARGE is in accordance with the room size within which the refrigerant containing parts are installed.
- The ventilation machinery and outlets are operating adequately and are not obstructed.
- If an indirect refrigerating circuit is being used, the secondary circuit shall be checked for the presence of refrigerant.
- Marking to the equipment continues to be visible and legible. Markings that are illegible shall be corrected.
- Refrigerating pipe or components are installed in a position where they are unlikely to be exposed to any substance which may corrode refrigerant containing components, unless the components are constructed of materials which are inherently resistant to being corroded or are suitably protected against being so corroded.

### **Checks to electrical devices**

Repair and maintenance to electrical components shall include initial safety checks and component inspection procedures. If a fault exists that could compromise safety, then no electrical supply shall be connected to the circuit until it is satisfactorily dealt with. If the fault cannot be corrected immediately but it is necessary to continue operation, an adequate temporary solution shall be used. This shall be reported to the owner of the equipment so all parties are advised.

Initial safety checks shall include:

- that capacitors are discharged: this shall be done in a safe manner to avoid possibility of sparking;
- that no live electrical components and wiring are exposed while charging, recovering or purging the system;
- that there is continuity of earth bonding.

### **Sealed electrical and intrinsically safe components**

- All sealed electrical components shall be replaced. All intrinsically safe components must be replaced.

### **Cabling**

- Check that cabling will not be subject to wear, corrosion, excessive pressure, vibration, sharp edges or any other adverse environmental effects. The check shall also take into account the effects of aging or continual vibration from sources such as compressors or fans.

### **Detection of flammable refrigerants**

- Under no circumstances shall potential sources of ignition be used in the searching for or detection of refrigerant leaks. A halide torch (or any other detector using a naked flame) shall not be used.
- The following leak detection methods are deemed acceptable for all refrigerant systems.

- Electronic leak detectors may be used to detect refrigerant leaks but, in the case of **FLAMMABLE REFRIGERANTS**, the sensitivity may not be adequate, or may need re-calibration. (Detection equipment shall be calibrated in a refrigerant-free area.) Ensure that the detector is not a potential source of ignition and is suitable for the refrigerant used. Leak detection equipment shall be set at a percentage of the LFL of the refrigerant and shall be calibrated to the refrigerant employed, and the appropriate percentage of gas (25 % maximum) is confirmed.
- Leak detection fluids are also suitable for use with most refrigerants but the use of detergents containing chlorine shall be avoided as the chlorine may react with the refrigerant and corrode the copper pipe-work.

**NOTE:** Examples of leak detection fluids are:

- bubble method; or
- fluorescent method agents.
- If a leak is suspected, all naked flames shall be removed/ extinguished.
- If a leakage of refrigerant is found which requires brazing, all of the refrigerant shall be recovered from the system, or isolated (by means of shut off valves) in a part of the system remote from the leak. Removal of refrigerant shall be according to instructions above.

### **Removal and evacuation**

- When breaking into the refrigerant circuit to make repairs, or for any other purpose, conventional procedures shall be used. However, for flammable refrigerants it is important that best practice be followed, since flammability is a consideration.
- The following procedure shall be adhered to:
  - a. safely remove refrigerant following local and national regulations
  - b. purge the circuit with inert gas
  - c. evacuate
  - d. purge with inert gas
  - e. open the circuit by cutting or brazing
- The refrigerant charge shall be recovered into the correct recovery cylinders. For appliances containing flammable refrigerants, the system shall be purged with oxygen-free nitrogen to render the appliance safe for flammable refrigerants. This process might need to be repeated several times.
- Compressed air or oxygen shall not be used for purging refrigerant systems.
- For appliances containing flammable refrigerants, refrigerants purging shall be achieved by breaking the vacuum in the system with oxygen-free nitrogen and continuing to fill until the working pressure is achieved, then venting to atmosphere, and finally pulling down to a vacuum.
- When the final oxygen-free nitrogen charge is used, the system shall be vented down to atmospheric pressure to enable work to take place.

- Ensure that the outlet for the vacuum pump is not close to any potential ignition sources and that ventilation is available.

### **Charging procedures**

#### ***In addition to conventional charging procedures, the following requirements shall be followed.***

- Ensure that contamination of different refrigerants does not occur when using charging equipment.
- Hoses or lines shall be as short as possible to minimise the amount of refrigerant contained in them.
- Cylinders shall be kept in an appropriate position according to the instructions.
- Ensure that the REFRIGERATING SYSTEM is earthed prior to charging the system with refrigerant.
- Label the system when charging is complete (if not already).
- Extreme care shall be taken not to overfill the REFRIGERATING SYSTEM.
- Prior to recharging the system, it shall be pressure-tested with the appropriate purging gas. The system shall be leak-tested on completion of charging but prior to commissioning. A follow up leak test shall be carried out prior to leaving the site.

### **Decommissioning**

#### ***Before carrying out this procedure, it is essential that the technician is completely familiar with the equipment and all its detail. It is recommended good practice that all refrigerants are recovered safely.***

#### ***Prior to the task being carried out, an oil and refrigerant sample shall be taken in case analysis is required prior to re-use of recovered refrigerant.***

#### ***It is essential that electrical power is available before the task is commenced.***

- Become familiar with the equipment and its operation.
- Isolate system electrically.
- Before attempting the procedure, ensure that mechanical handling equipment is available, if required, for handling refrigerant cylinders; all personal protective equipment is available and being used correctly; the recovery process is supervised at all times by a competent person; recovery equipment and cylinders conform to the appropriate standards.
- Pump down refrigerant system, if possible.
- If a vacuum is not possible, make a manifold so that refrigerant can be removed from various parts of the system.
- Make sure that cylinder is situated on the scales before recovery takes place.

- Start the recovery machine and operate in accordance with instructions.
- Do not overfill cylinders (no more than 80 % volume liquid charge).
- Do not exceed the maximum working pressure of the cylinder, even temporarily.
- When the cylinders have been filled correctly and the process completed, make sure that the cylinders and the equipment are removed from site promptly and all isolation valves on the equipment are closed off.
- Recovered refrigerant shall not be charged into another REFRIGERATING SYSTEM unless it has been cleaned and checked.

### **Labeling**

#### ***Equipment shall be labelled stating that it has been de-commissioned and emptied of refrigerant. The label shall be dated and signed. For appliances containing FLAMMABLE REFRIGERANTS, ensure that there are labels on the equipment stating the equipment contains FLAMMABLE REFRIGERANT.***

### **Lubrication**

R-32 should only be used with manufacturer-approved oil, such as DAPHNE FW68DE. The HFC refrigerant components in R-32 will not be compatible with mineral oil or alkylbenzene lubricants. R-32 systems will be charged with the OEM recommended lubricant, ready for use with R-32.

### **Leak Detection**

NEVER use the following when attempting to detect R-32 refrigerant leaks:

- A halide torch (or any other detector using a naked flame)
- Substances containing chlorine
- Electronic leak detection

### **Pressure Testing and Refrigerant Evacuation**

- Make sure that air or any matter other than R-32 refrigerant does not enter the refrigeration cycle.
- If refrigerant gas leaks occur in an enclosed area, ventilate the space as soon as possible.
- R-32 should always be recovered and never released directly into the environment.
- Only use tools meant for use on R-32 refrigerant (such as a gauge manifold, charging hose, or vacuum pump adapter).

## Commissioning

- Ensure proper connection of all piping and carry out a leak test before charging with refrigerant.
- Check safety equipment before putting into service.

## Decommissioning

ALWAYS remove refrigerant charge before decommissioning the unit.

- Ensure sufficient ventilation at the equipment location.
- Be aware that malfunction of the equipment may be caused by refrigerant loss and a refrigerant leak is possible.
- Discharge capacitors in a way that won't cause any spark.
- R-32 should always be recovered and never released directly into the environment. Take care that the drained refrigerant will not cause any danger. In doubt, one person should guard the outlet. Take special care that drained refrigerant will not float back into the building.

## Recovery

### Recovery Cylinders

When transferring refrigerant into cylinders, ensure that only appropriate refrigerant recovery cylinders are employed. Ensure that the correct number of cylinders for holding the total system charge is available. All cylinders to be used should be designated for the recovered refrigerant and labeled for that refrigerant. Cylinders should be complete with a pressure-relief valve and associated shut-off valves in good working order. Empty recovery cylinders should be evacuated and, if possible, cooled before recovery occurs.

### Recovery Equipment

The recovery equipment should be in good working order with a set of instructions concerning the equipment that is at hand and shall be suitable for the recovery of all appropriate refrigerants including, when applicable, **FLAMMABLE REFRIGERANTS**. In addition, a set of calibrated weighing scales shall be available and in good working order. Hoses shall be complete with leak-free disconnect couplings and in good condition. Before using the recovery machine, check that it is in satisfactory working order, has been properly maintained and that any associated electrical components are sealed to prevent ignition in the event of a refrigerant release. Consult manufacturer if in doubt.

### Recovered Refrigerant

The recovered refrigerant should be returned to the refrigerant supplier in the correct recovery cylinder with the relevant waste transfer note assigned. Do not mix refrigerants in recovery units and especially not in cylinders.

## Compressor or Compressor Oils

If compressors or compressor oils are to be removed, ensure that they have been evacuated to an acceptable level to make certain that no refrigerant remains within the lubricant. The evacuation process should be carried out prior to returning compressors to the supplier(s). Only electric heating to the compressor body shall be employed to accelerate this process.

## Handling and Storage

### Precautions for Safe Handling

- Waste air is to be released into the atmosphere only via suitable separators. Open and handle receptacle with care.
- Keep ignition sources away.
- Do not smoke near the unit.
- Protect against electrostatic charges.

### Conditions for Safe Storage

- Requirements to be met by storerooms and receptacles:
  - Store only in unopened original receptacles
  - Store in a cool and dry location
- Further information about storage conditions:
  - Keep container tightly sealed
  - Store in cool, dry conditions in well sealed receptacle
  - Protect from heat and direct sunlight
- Maximum storage temperature:
  - 104°F (40°C)

## Disposal

- Waste treatment method recommendation:
  - Must be specially treated adhering to official regulations.
  - Incineration in an adequate incinerator is recommended.
  - Uncleaned packaging disposal must be made according to official regulations.
- Ensure sufficient ventilation at the working place.
- Remove the refrigerant. R-32 should always be recovered and never released directly into the environment. Take care that the drained refrigerant will not cause any danger. In doubt, one person should guard the outlet. Take special care that drained refrigerant will not float back into the building.
- Evacuate the refrigerant circuit.
- Purge the refrigerant circuit with nitrogen for 5 min.
- Evacuate again.
- Cut out the compressor and drain the oil

## Competence of Personnel

There are specific procedures that must be followed for the installation, repair, maintenance, and decommissioning of equipment that uses A2L refrigerants.

Training for these procedures is carried out by national training organizations or manufacturers that are accredited to teach the relevant national competency standards that may be set in legislation. The achieved competence should be documented by a certificate.

## Information and Training

### *The training should include the substance of the following*

- Information about the explosion potential of flammable refrigerants to show that flammables may be dangerous when handled without care.
- Information about potential ignition sources, especially those that are not obvious, such as lighters, light switches, vacuum cleaners, electric heaters.
- Information about the different safety concepts:
  - Unventilated: Safety of the appliance does not depend on ventilation of the housing. Switching off the appliance or opening of the housing has no significant effect on safety. Nevertheless, it is possible that leaking refrigerant may accumulate inside the enclosure and flammable atmosphere will be released when the enclosure is opened.
  - Ventilated enclosure: Safety of the appliance depends on ventilation of the housing. Switching off the appliance or opening of the enclosure has a significant effect on safety. Care should be taken to ensure sufficient ventilation before.
  - Ventilated room: Safety of the appliance depends on the ventilation of the room. Switching off the appliance or opening of the housing has no significant effect on safety. The ventilation of the room shall not be switched off during repair procedures.
- Information about refrigerant detectors:
  - Principle of function, including influences on the operation.
  - Procedures, how to repair, check or replace a refrigerant detector or parts of it in a safe way.
  - Procedures, how to disable a refrigerant detector in case of repair work on the refrigerant carrying parts.
- Information about the concept of sealed components and sealed enclosures according to IEC 60079-15:2010.
- Information about the correct working procedures:
  - Commissioning
    - a. Ensure that the floor area is sufficient for the refrigerant charge or that the ventilation duct is assembled in a correct manner.
    - b. Connect the pipes and carry out a leak test before charging with refrigerant.
  - Maintenance
    - c. Check safety equipment before putting into service.
  - Repair
    - a. Portable equipment shall be repaired outside or in a workshop specially equipped for servicing units with flammable refrigerants.
    - b. Ensure sufficient ventilation at the repair place.
    - c. Be aware that malfunction of the equipment may be caused by refrigerant loss and a refrigerant leak is possible.
    - d. Discharge capacitors in a way that won't cause any spark.
    - e. Reassemble sealed enclosures accurately. If seals are worn, replace them.
    - f. Check safety equipment before putting into service.
- Removal of the refrigerant. R-32 should always be recovered and never released directly into the environment. Take care that the drained refrigerant will not cause any danger. In doubt, one person should guard the outlet. Take special care that drained refrigerant will not float back into the building.
- Evacuation the refrigerant circuit.
- Removal of parts to be replaced by cutting, not by flame.
- Purging the braze point with nitrogen during the brazing procedure.
- Carrying out a leak test before charging with refrigerant.
  - a. Reassemble sealed enclosures accurately. If seals are worn, replace them.
  - b. Check safety equipment before putting into service.
- Decommissioning
  - a. The refrigerant charge must be removed before decommissioning.
  - b. Ensure sufficient ventilation at the equipment location.
  - c. Be aware that malfunction of the equipment may be caused by refrigerant loss and a refrigerant leak is possible.
  - d. Discharge capacitors in a way that won't cause any spark.

- e. Remove the refrigerant. R-32 should always be recovered and never released directly into the environment. Take care that the drained refrigerant will not cause any danger. In doubt, one person should guard the outlet. Take special care that drained refrigerant will not float back into the building.
- Disposal
- a. Ensure sufficient ventilation at the working place.
  - b. Remove the refrigerant. R-32 should always be recovered and never released directly into the environment. Take care that the drained refrigerant will not cause any danger. In doubt, one person should guard the outlet. Take special care that drained refrigerant will not float back into the building.

## Maintenance

- Equipment shall be repaired outside or in a workshop specially equipped for servicing units with A2L refrigerants.
- Ensure sufficient ventilation at the location where repairs are taking place.
- Be aware that malfunction of the equipment may be caused by refrigerant loss and a refrigerant leak is possible.
- Discharge capacitors in a way that won't cause sparks. Do we need to provide this?
- When repairs are Reassemble sealed enclosures. If seals are worn, replace them.
- Check safety equipment before putting into service.

## Repair

- Portable equipment shall be repaired outside or in a workshop specially equipped for servicing units with FLAMMABLE REFRIGERANTS.
- Ensure sufficient ventilation at the repair place.
- Be aware that malfunction of the equipment may be caused by refrigerant loss and a refrigerant leak is possible.
- Discharge capacitors in a way that won't cause any spark.
- When brazing is required, the following procedures shall be carried out in the right order:
  - Remove the refrigerant. R-32 should always be recovered and never released directly into the environment. Take care that the drained refrigerant will not cause any danger. In doubt, one person should guard the outlet. Take special care that drained refrigerant will not float back into the building.
  - Evacuate the refrigerant circuit.
  - Remove parts to be replaced by cutting, not by flame.
  - Purge the braze point with nitrogen during the brazing procedure.
  - Carry out a leak test before charging with refrigerant.
- Reassemble sealed enclosures accurately. If seals are worn, replace them.
- Check safety equipment before putting into service.

# Maintenance

## Performing Service Maintenance

**WARNING**

**Moving machinery and electrical power hazards. May cause severe personal injury or death.** Disconnect and lock off all power before servicing equipment.

**CAUTION**

**Sharp edges are inherent to sheet metal parts, screws, clips, and similar items. May cause personal injury.** Exercise caution when servicing equipment.

**NOTICE**

**Chilled Water Piping:** A qualified Architect or Systems HVAC Design Engineer familiar with piping design, local codes and regulations, must provide piping design. The following manufacturer recommendations serve as a general guide and should not replace a qualified professional's piping system design.

**NOTICE**

**Refrigerant Piping:** A qualified Architect or Systems HVAC Design Engineer familiar with refrigerant piping design, as well as local codes and regulations, must provide refrigerant piping design. The following manufacturer recommendations serve as a general guide and should not replace a qualified professional's refrigerant piping system design.

**WARNING**

**Hazardous voltage. May cause severe injury or death.** Disconnect electric power before servicing equipment. More than one disconnect may be required to de-energize the unit.

Installation and maintenance must be performed only by qualified personnel who are experienced with this type of equipment and familiar with local codes and regulations.

## Servicing Control Panel Components

Disconnect all electric power to the unit when servicing control panel components. Before servicing, always inspect units for multiple disconnects to ensure all power is removed from the control panel and its components.

## Planned Maintenance

Preventive maintenance is the best way to avoid unnecessary expense and inconvenience. Have this system inspected at regular intervals by a qualified service technician. The required frequency of inspections depends upon the total operating time and the indoor and outdoor environmental conditions. Routine maintenance should cover the following items:

- Tighten all belts, wire connections, and setscrews.
- Clean the evaporator and condenser coils mechanically or with cold water, if necessary. Usually any fouling is only matted on the entering air face of the coil and can be removed by brushing or vacuuming.

- Lubricate the motor and fan shaft bearings.
- Align or replace the belts as required.
- Clean or replace the filters as required.

**NOTE:** A partially full sight glass is not uncommon at part load conditions. A varying amount of bubbles may be noticeable in the sightglass, which is normal.

- Check for proper superheat.
- Check for blockage of the condensate drain. Clean the condensate pan as needed.
- Check the line voltages for imbalance of 2% or less.
- Check the running amperage of all motors.
- Check all operating temperatures and pressures.
- Check and adjust all temperature and pressure controls as needed.
- Check and adjust all damper linkages as needed.
- Check the operation of all safety controls.
- Check the condenser fans and tighten their setscrews.
- Check inlets of all control panel and VFD cooling fans for debris/blockage and clear if necessary (with power disconnected).
- Check all control panel and VFD cooling fans are operational.

## All-Aluminum Condenser Coils

The condenser coils are an all-aluminum design including the connections, micro-channels, fins (an oven brazing process brazes the fins to the micro-channel flat tube), and headers (Figure 58), which eliminates the possibility of corrosion normally found between dissimilar metals of standard coils.

During the condensing process, refrigerant in the coil passes through the micro-channel flat tubes, resulting in higher efficiency heat transfer from the refrigerant to the airstream.

In the unlikely occurrence of a coil leak, contact Daikin Applied to receive a replacement coil module.

**Figure 58: Micro-Channel Coil Cross-Section**

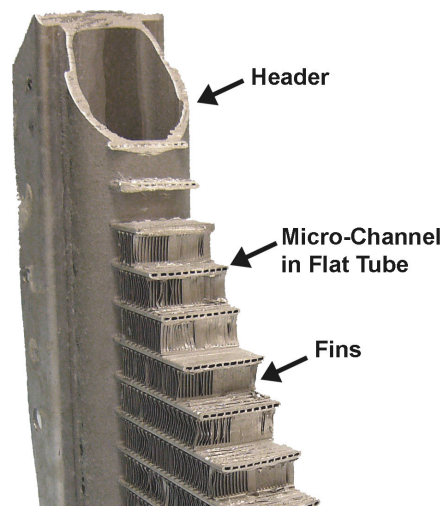

## Connecting the Condenser Coil to Copper Tubing

**⚠ CAUTION**

Potential equipment damage. If a standard copper brazing process is performed at this joint, the process will damage the aluminum connection. If a condenser coil ever needs to be replaced, the copper aluminum joint repair should be done with a ProBraz™ repair kit manufactured by OmniTechnologies Corporation. A non-corrosive flux must also be used. The brazing temperature should be between 850°F–900°F (454.4°C–482.2°C). If a coil needs replacing, contact Daikin Applied for a coil and copper connection assembly.

Figure 59 shows the aluminum condenser coil connection to the copper tubing in the unit. Because of the low melting point of aluminum (1220°F (660°C) compared to 1984°F (1084°C) for copper), this brazed joint is performed with a low temperature brazing process.

**Figure 59: Aluminum/Copper Connection**



## Cleaning Option E Coated Coils

**⚠ WARNING**

**Hazardous voltage. May cause severe injury or death.** Disconnect electric power prior to cleaning the unit. More than one disconnect may be required to de-energize the unit.

The following cleaning procedures are recommended as part of the routine maintenance activities for Option E Coated Coils. Documented routine cleaning of Option E Coated Coils is required to maintain warranty coverage.

### Remove Surface Loaded Fibers

Surface loaded fibers or dirt should be removed prior to water rinse to prevent further restriction of airflow. If unable to back wash the side of the coil opposite that of the coils entering air side, then surface loaded fibers or dirt should be removed with a vacuum cleaner. If a vacuum cleaner is not available, a soft non-metallic bristle brush may be used. In either case, the tool should be applied in the direction of the fins. Coil surfaces can be easily damaged (fin edges bent over) if the tool is applied across the fins.

**NOTE:** Use of a water stream, such as a garden hose, against a surface loaded coil will drive the fibers and dirt into the coil. This will make cleaning efforts more difficult. Surface loaded fibers must be completely removed prior to using low velocity clean water rinse.

### Periodic Clean Water Rinse

A monthly clean water rinse is recommended for coils that are applied in coastal or industrial environments to help to remove chlorides, dirt and debris. An elevated water temperature (not to exceed 130°F) will reduce surface tension, increasing the ability to remove chlorides and dirt. Pressure washer PSI must not exceed 900 psig and the nozzle should remain at least 1 foot from the coil to avoid damaging fin edges.

### Routine Quarterly Cleaning of Option E Coated Coil Surfaces

Quarterly cleaning is essential to extend the life of an Option E Coated Coil and is required to maintain warranty coverage. Coil cleaning shall be part of the unit's regularly scheduled maintenance procedures. Failure to clean an Option E Coated Coil will void the warranty and may result in reduced efficiency and durability in the environment.

For routine quarterly cleaning, first clean the coil with the below approved coil cleaner (see approved products list under Recommended Coil Cleaners section, Table 17). After cleaning the coils with the approved cleaning agent, use the approved chloride remover (under the Recommended Chloride Remover section) to remove soluble salts and revitalize the unit.

### Recommended Coil Cleaner

The following cleaning agent, assuming it is used in accordance with the manufacturer's directions on the container for proper mixing and cleaning, has been approved for use on Option E Coated Coils to remove mold, mildew, dust, soot, greasy residue, lint and other particulate:

**Table 17: Option E Coated Coil Recommended Cleaning Agents**

Cleaning Agent	Reseller	Part Number
Enviro-Coil Concentrate	Hydro-Balance Corp P.O. Box 730 Prosper, TX 75078 800-527-5166	H-EC01
Enviro-Coil Concentrate	Home Depot	H-EC01
Chloride Remover	Chlor*Rid Int'l, Inc. P.O. Box 908 Chandler AZ 85244 800-422-3217	Chlor*Rid DTS

CHLOR\*RID DTS™ should be used to remove soluble salts from the Option E Coated Coil, but the directions must be followed closely. This product is not intended for use as a degreaser. Any grease or oil film should first be removed with the approved cleaning agent.

1. Remove Barrier - Soluble salts adhere themselves to the substrate. For the effective use of this product, the product must be able to come in contact with the salts. These salts may be beneath any soils, grease or dirt; therefore, these barriers must be removed prior to application of this

product. As in all surface preparation, the best work yields the best results.

2. Apply CHLOR\*RID DTS - Apply CHLOR\*RID DTS directly onto the substrate. Sufficient product must be applied uniformly across the substrate to thoroughly wet out surface, with no areas missed. This may be accomplished by use of a pump-up sprayer or conventional spray gun. The method does not matter, as long as the entire area to be cleaned is wetted. After the substrate has been thoroughly wetted, the salts will be soluble and is now only necessary to rinse them off.
3. Rinse - It is highly recommended that a hose be used, as a pressure washer will damage the fins. The water to be used for the rinse is recommended to be of potable quality, though a lesser quality of water may be used if a small amount of CHLOR\*RID DTS is added. Check with CHLOR\*RID International, Inc. for recommendations on lesser quality rinse water.

**Cautions**

**Harsh Chemical and Acid Cleaners**

Harsh chemicals, household bleach or acid cleaners should not be used to clean outdoor or indoor Option E Coated Coils. These cleaners can be very difficult to rinse out of the coil and can accelerate corrosion and attack the Option E coating. If there is dirt below the surface of the coil, use the recommended coil cleaners as described above.

**High Velocity Water or Compressed Air**

High velocity water from a pressure washer or compressed air should only be used at a very low pressure to prevent fin and/or coil damages. The force of the water or air jet may bend the fin edges and increase airside pressure drop. Reduced unit performance or nuisance unit shutdowns may occur.

**Coil Cleaning for Non-Coated Coils**

- Clean as needed
- No chemicals or pressure washer use
- Vacuum and spray with water

**Control Panel Components**

The following individual motor protection is provided.

**Table 18: Maverick Individual Motor Control and Protection**

Motor Type	Short Circuit	Overload	ON-OFF
Compressor < 100 Amps	MMP	Internal	Contactors
Condenser Fans	MMP	Internal	Contactors
EAF, no VFD, 208-460V	MMP	MMP	Contactors
EAF, no VFD, 575V	MMP	MMP	Contactors
EAF with VFD	Fuse	VFD	VFD
SAF with VFD	Fuse	VFD	VFD
SAF, no VFD	MMP	MMP	Contactors

MMP = manual motor protector  
 Internal = vendor motor protector with internal sensors  
 CB = circuit breaker [\* FB with MD4 VFD]  
 OL = over load relay

**Manual Motor Protector (MMP)**

The manual motor protector (MMP) provides coordinated branch circuit, short circuit protection, a disconnecting means, a motor controller, and coordinated motor overload protection. A short circuit indicator with manual reset is mounted along side of each MMP as a means to differentiate between a short circuit and overload trip conditions.

The MMP trip points are factory set. Do not change unless the motor ampacity changes or the MMP is replaced with a new device with incorrect setpoint adjustment. Any other non-authorized trip point or setpoint adjustment voids all or portions of the unit’s warranty. Authorized setpoint adjustment is accomplished as follows

1. For motors with a 1.15 service factor, rotate the arrow on the dial to correspond to the motor FLA.
2. For motors with a 1.0 service factor, multiply the motor FLA by 0.9; then rotate the arrow on the dial to correspond to that value.

To reset a tripped MMP, clear the trip by rotating the knob counterclockwise to the OFF (O) position; then rotate knob clockwise to the ON (I) position. See Figure 60.

**⚠ WARNING**

If an overload or a fault current interruption occurs, check circuits to determine the cause of the interruption. If a fault condition exists, examine the controller. If damaged, replace it to reduce the risk of fire or electrical shock.

**Other MMP Features:**

- Three-position rotary operator: OFF (O)-TRIP-ON (I) (Figure 60).
- Lockout—tagoutable rotary operator: turn the rotary operator to OFF (O), slide out the extension arm, and insert a lockout pin.
- Ambient compensated –20°C to +40°C.
- Single-phase sensitivity: if one phase exceeds setpoint, all three phases open.
- Trip test: insert a 9/64” screw driver in the test slot to simulate a trip.

**Figure 60: Manual Motor Protector and Contactor**



## Thermal Overload Relay

Designed to provide current-dependent protection for loads with normal starting against impermissibility high temperature rises due to overload, phase asymmetry or phase failure. Increase in motor current beyond set point as a result to overload or phase failure will trip the overload and disconnect the motor.

The Relay trip points are factory set. Do not change unless the motor ampacity changes or the Relay is replaced with a new device with incorrect set point adjustment. Any other non-authorized trip points or set points adjustment voids all or portions of the unit's warranty. Authorized set point adjustment is accomplishment as follows:

1. For motors with 1.15 service factor, rotate the arrow on the dial to correspond to the motor FLA (See Figure 61).
2. For motors with a 1.0 service factor, multiply the motor FLA with 0.9; then rotate the arrow on the dial to correspond to that value.

To reset a tripped Relay, push the blue RESET button. To disconnect, push the Red stop Button.

### Other Relay features:

- Three connection systems options, Screw type, spring loaded and ring cable lug connection.
- Switch position indicator to indicate a trip and TEST function for wiring.
- Large rotary button to adjust current to Motor RLA.
- Selector switch for manual/and automatic RESET.

Figure 61: Overload Relay



## Fuses

**CAUTION**

Risk of fire or ARC-flash. Replace fuses only with identical type and rating

Fast-acting fuses are installed upstream of all VFDs to provide the ultimate in short-circuit protection of the equipment and ARC-flash protection of the users and maintenance personnel. Fuses are not resettable and therefore must be replaced to restore operation of the unit.

If a fuse is found to be "open" or tripped, the cause must be investigated before replacing the fuse. Inspect all the associated wiring first of course, but do not rule out the fact that the equipment being protected may be defective, which is most often the case.

## Field Wiring Terminals

All field wiring terminals are spring clamp type, which offer several advantages over traditional screw-type terminals:

- Spring connections do not require torquing
- Spring connections resist failure due to vibration
- Easily identifiable terminal markers
- Combination spring release and square test ports

Wire connections require inserting ("1" in Figure 62) a stripped wire a round port and clamping the stripped wire by inserting a small flat-bladed screw driver in the adjacent square port ("2").

Figure 62: Terminal Connectors (Typical 3-position Shown)

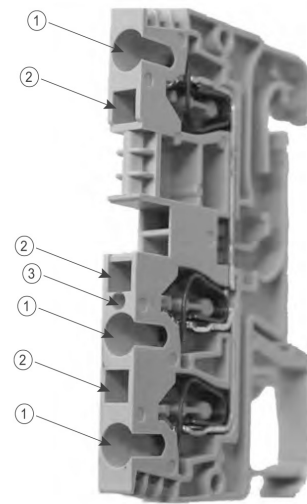

## Phase Voltage Monitor (PVM)

When the proper three-phase line voltage is applied to the unit and the phase sequence (rotation) is correct, the relay is energized after the reset delay is completed. Any one of five fault conditions will de-energize the relay after a delay. As standard, re-energization is automatic upon correction of the fault condition.

Table 19: LED Indication

	LED Status	Status
Green		Normal (Relay ON)
		Restart (Delay)
Red		Reversal
		Loss/UB (Unbalance)
		Low Volt (Under Voltage)
		High Volt (Over Voltage)

### Factory Setpoints:

- Unbalance: 3% nominal, 4% maximum
- Trip Delay: 5 seconds
- Voltage Line–Line: 208, 230, or 460 per unit nameplate or value on schematic
- Restart Delay: 100 seconds
- Undervoltage: 92% nominal, 90% maximum

**NOTE:** Under voltage and voltage imbalance is a common cause of motor overload. Running the system with excessive supply voltage abnormality risks damaging expensive components like compressors and fan motors

**NOTE:** PVM relays are set at the factory. The alteration of factory settings will void the warranty on the unit

### Through-the-Door Disconnect

**⚠ DANGER**

**Hazardous voltage. May cause severe injury or death.** Disconnect electric power before servicing equipment. More than one disconnect may be required to de-energize the unit.

**Opening the through-the-door disconnect without performing a proper machine shut-down is not recommended except in emergencies.**

The optional disconnect provides for locking out power to the unit. To lock out power to the unit, rotate the handle to the “Reset/ Lock” position and insert a padlock or locking device through the base of the handle. **Do not lockout the handle with the Interlock in bypass mode.**

*Figure 63: Through-the-Door Handle Disconnect*



### Servicing Optional Electric Heater

**⚠ WARNING**

**Hazardous voltage. May cause severe injury or death.** Disconnect electric power before servicing equipment. More than one disconnect may be required to de-energize the unit.

If the electric heater is not operating properly, a qualified electrician should perform the following to check if the heater is damaged:

1. Measure continuity through all fuses.
2. Check that all electrical connections are tight. Look for signs of arcing.
3. Check the resistance to ground for each circuit. It should be infinite.
4. Check the resistance phase to phase for each circuit.
5. Check all contactors.

### Unit Storage

#### Location

The Maverick II is an outdoor unit. However, the construction schedule may dictate storage either on the ground or in its final position at the site. If the unit is stored on the ground, additional precautions should be taken as follows:

- Make sure that the unit is well supported along the length of the base rail.
- Make sure that the unit is level (no twists or uneven ground surface).
- Provide proper drainage around the unit to prevent flooding of the equipment.
- Provide adequate protection from vandalism, mechanical contact, etc.
- Make sure all doors are securely closed and all latches closed.
- Units should be fitted with covers over the supply and return air openings.

### Preparation for Storage

#### Supply Fans

1. Remove the drive belts, tag them with the fan name and unit serial number, and store them in a conditioned space out of direct sunlight.
2. Once every two weeks, rotate the fan and motor shafts. Mark the shaft positions first to make sure they stop in a different position.
3. Depending on local climate conditions, condensate may collect on components inside the units. To prevent surface rust and discoloration, spray all bare metal parts with a rust preventive compound. Pay close attention to fan shafts, sheaves, bearings, and bearing supports.

## Cabinet Sections

Once a month, open a door on each section and verify that no moisture or debris is accumulating in the unit.

## Control Compartment

1. Daikin Applied recommends that the electronic control equipment in the unit be stored in a 5% to 95% RH (non-condensing) environment.
2. It may be necessary to put a heat source (light bulb) in the main control panel to prevent the accumulation of atmospheric condensate within the panel. The location and wattage of the heat source is dependent on local environmental conditions.
3. Check the control compartment every two weeks to confirm that the heat source is functional and is adequate for current conditions.
4. Thermostatically controlled cabinet heaters are available through the Daikin Applied Parts group.

## Restart

After extended storage, perform a complete start up. Inevitable accumulations of dirt, insect nests, etc., can contribute to problems if not cleaned out thoroughly prior to start up. In addition, thermal cycling tends to loosen mechanical and electrical connections. Following the startup procedure helps discover these and other issues that may have developed during the storage interval.

## Bearing Lubrication



### CAUTION

**Bearing overheating potential can damage the equipment.**  
Do not overlubricate bearings. Use only a high grade mineral grease with a 200°F (93.3°C) safe operating temperature.

## Motor Bearings

### Supply Fans

Supply fan motors should have grease added after every 2000 hours of operation. Use one of the greases shown in [Table 20](#). Using the following procedure, relubricate the bearings while the motor is warm, but not running.

1. Remove and clean upper and lower grease plugs.
2. Insert a grease fitting into the upper hole and add a small amount of clean grease with a low pressure gun.
3. Install the lower grease plug.
4. Run the motor for five minutes before installing the upper grease plug.

### Condenser Fan and Exhaust Fan

The condenser fan and exhaust fan motors are permanently lubricated and require no periodic lubrication.

## Fan Shaft Bearings

Relubricate fan shaft bearings periodically. Relubricate according to the schedule on the fan housing. If the bearings are exposed to wet conditions, wide temperature variations, or other severe atmospheric conditions, relubricate more frequently. Use one of the greases shown in [Table 20](#).

While the bearing is at normal operating temperatures, rotate the fan by hand and add only enough grease to purge the seals. The seals bleed slightly when this occurs. Do not overlubricate.

**Table 20: Recommended Greases**

Manufacture	Product Name	Temp. Range (°F)
Texaco Lubricants Co.	Premium RB	-30 to 300
Mobil Oil Corporation	Mobilith AW2	-40 to 325
Mobil Oil Corporation	Polyrex EM or equivalent	
Shell Oil Company	Alvania No. 2	-20 to 240

## Vibration Levels

Each unit as shipped is trim balanced to operate smoothly. To provide satisfactory operation after shipping and installation, use accepted industry guidelines for field balancing fans.

**NOTE:** Excessive vibration from any cause contributes to premature fan and motor bearing failure. Monitor overall vibration levels every six months of operation. An increase in levels is an indication of potential trouble.

### Vibration Causes

1. Wheel imbalance.
  - a. Dirt or debris on wheel blades.
  - b. Loose setscrews in wheel hub or bearing-to-shaft.
  - c. Wheel distorted from overspeed.
2. Bent shaft.
3. Faulty drive.
  - a. Bad V-belts; lumpy, or mismatched.
  - b. Belt tension too tight or too loose.
4. Bad bearings or loose bearing hold-down bolts.
5. Motor imbalance.
6. Fan section not supported evenly on foundation.

## Periodic Service and Maintenance

1. Check all moving parts for wear every six months.
2. Check bearing collar, sheave, and wheel hub setscrews, sheave capscrews, and bearing hold-down bolts for tightness every six months.

## Energy Recovery Wheel Maintenance

**⚠ CAUTION**

Installation and maintenance must be performed only by qualified personnel who are experienced with this type of equipment and familiar with local codes and regulations.

**⚠ WARNING**

Moving machinery and electrical power hazards. Can cause severe personal injury or death. Disconnect and lock off all power before servicing equipment.

**⚠ CAUTION**

Sharp edges are inherent to sheet metal parts, screws, clips, and similar items. Contact with these edges may cause personal injury. Exercise caution when servicing equipment.

**⚠ DANGER**

Hazardous voltage. Will cause severe injury or death. Disconnect electric power before servicing equipment. More than one disconnect may be required to de-energize the unit.

### Servicing Control Panel Components

Disconnect all electric power to the unit when servicing control panel components. Before servicing, always inspect units for multiple disconnects to ensure all power is removed from the control panel and its components.

### Bearings

Enthalpy wheels are provided with “no maintenance” inboard bearings, requiring no maintenance during the life of the equipment.

### Drive Motor

The drive motor should require no maintenance. The wheel drive motor bearings are pre-lubricated and no further lubrication is necessary. The wheel drive pulley is secured to the drive motor shaft by a combination of either a key or D slot or setscrew. The set screw is secured with removable locktite to prevent loosening. Annually confirm set screw is secure.

### Drive Belts

The wheel drive belt is a urethane stretch belt designed to provide constant tension through the life of the belt. No adjustment is required. Inspect the drive belt annually for proper tracking and tension. A properly tensioned belt will turn the wheel immediately after power is applied with no visible slippage during start-up.

Belts are multilink with individual links constructed of a high performance polyurethane elastomer, reinforced with multiple plies of polyester fabric. This belt provides a strong, yet flexible belting. The multilink feature provides easy servicing or replacement.

### Seals

The seals are designed to be durable and require no maintenance other than adjustment. If seals become worn or damaged they may easily be replaced. The seals are made to clip onto the cassette or metal post easily.

### Fans

Check cooling fan inlet for debris accumulation and confirm rotation and operation.

### Variable Frequency Controller

Should problems with the VFD develop, consult the VFD service manual that accompanied your order.

### Wheel

The enthalpy wheel is designed to last the life of the equipment. It is protected by an ASHRAE 30% filter to keep dust and dirt from the heat transfer surface. The wheel is somewhat self cleaning through its normal action of rotating in and out of countercurrent air flow streams. If the wheel becomes dirty, it may be cleaned by blowing out the unit with compressed air (20 psig maximum). In cases of severe dirt, the wheel may be removed from the cassette and washed with water following wheel removable procedures outlined below.

### Routine Maintenance

#### Cleaning

**⚠ CAUTION**

Do not use acid based cleaners, aromatic solvents, steam or temperatures in excess of 170°F; damage to the wheel may occur!

The need for periodic cleaning of the energy recovery wheel will be a function of operating schedule, climate and contaminants in the indoor air being exhausted and the outdoor air being supplied to the building.

The Daikin Applied wheel is “self-cleaning” with respect tiny particles due to its laminar flow characteristics. Smaller particles pass through; larger particles land on the surface and are blown clear as the flow direction is reversed. Any material that builds up on the face of the wheel can be removed with a brush or vacuum.

The primary need for cleaning is to remove oil based aerosols that have condensed on energy transfer surfaces. A characteristic of all dry desiccants, such films can close off micron sized pores at the surface of the desiccant material, reducing the efficiency by which the desiccant can adsorb and desorbs moisture and also build up so as to reduce airflow.

In a reasonably clean indoor environment such as school or office building, measurable reductions of airflow or loss of sensible (temperature) effectiveness may not occur for several years. Measurable changes in latent energy (water vapor) transfer can occur in shorter periods of time in applications such as moderate occupant smoking or cooking facilities.

In applications experiencing unusually high levels of occupant smoking or oil based aerosols such as industrial applications involving the ventilation of machine shop areas for example, annual washing of energy transfer may be necessary to maintain latent transfer efficiency. Proper cleaning of the energy recovery wheel will restore latent effectiveness to near original performance.

To clean, gain access to the energy recovery wheel and remove segments. Brush foreign material from the face of the wheel. Wash the segments or small wheels in a 5% solution of non-acid based coil cleaner (such as Acti-Klean, available through Daikin Applied, Stock # AK1) or alkaline detergent and warm water. Soak in the solution until grease and tar deposits are loosened (Note: some staining of the desiccant may remain and is not harmful to performance).

Before removing, rapidly run finger across surface of segment to separate polymer strips for better cleaning action. Rinse dirty solution from segment and remove excess water before reinstalling in wheel.

**Air Seals**

Four adjustable diameter seals are provided on each cassette to minimize transfer of air between the counter flowing airstreams.

To adjust diameter seals, loosen diameter seal adjusting screws and back seals away from wheel surface (Figure 64). Rotate wheel clockwise until two opposing spokes are hidden behind the bearing support beam. Using a folded piece of paper as a feeler gauge, position paper between the wheel surface and diameter seals. Adjust seals towards wheel surface until a slight friction on the feeler gauge (paper) is detected when gauge is moved along the length of the spoke. Retighten adjusting screws and recheck clearance with “feeler” gauge.

**Wheel Drive Components**

The wheel drive motor bearings are prelubricated and no further lubrication is necessary.

The wheel drive pulley is secured to the drive motor shaft by a combination of either a key or D slot or setscrew. The set screw is secured with removable locktite to prevent loosening. Annually confirm set screw is secure.

The wheel drive belt is a urethane stretch belt designed to provide constant tension through the life of the belt. No adjustment is required. Inspect the drive belt annually for proper tracking and tension. A properly tensioned belt will turn the wheel immediately after power is applied with no visible slippage during start-up.

**Figure 64: Adjusting Diameter Seals**

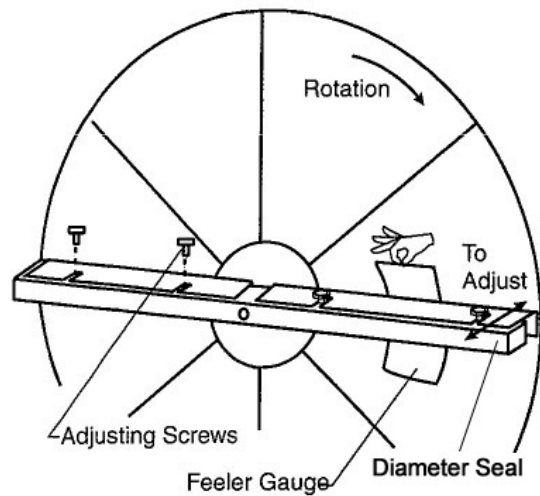

## Segment Installation & Replacement

Wheel segments are secured to the wheel frame by a Segment Retainer which pivots on the wheel rim and is held in place by a Segment Retaining Catch (Figure 65).

To install wheel segments follow steps 1 through 5 (Figure 66). Reverse the procedure for segment removal.

1. Disconnect power to the drive motor.
2. Unlock two segment retainers. There is one on each side of the selected segment opening.
3. With the embedded stiffener facing the motor side, insert the node of the segment between hub plates.
4. Holding the segment by the two outer corners, press the segment towards the center of the wheel and inwards against the spoke flanges. If hand pressure does not fully seat the segment, insert the flat tip of a screwdriver between the wheel rim and outer corners of the segment and apply downward force while guiding the segment into place.
5. Close and latch each Segment Retainer under the Segment Retaining Catch.
6. Slowly rotate the wheel 180°. Install the second segment opposite the first for counter balance. Rotate the two installed segments 90° to balance the wheel while the third segment is installed. Rotate the wheel 180° again to install the fourth segment opposite the third. Repeat this sequence with the remaining four segments.

Figure 65: Segment Retaining Clip

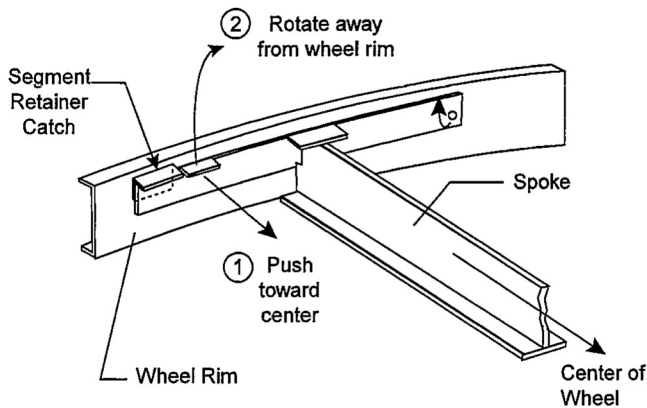
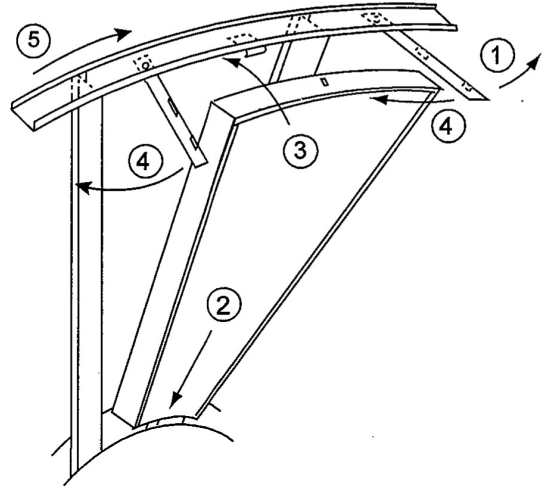

Figure 66: Installing Wheel Segments



## Wheel Drive Motor & Pulley Replacement

1. Disconnect power to the drive motor.
2. Remove belt from the pulley and position temporarily around the wheel rim.
3. Loosen the set screw in wheel drive pulley using Allen wrench and remove pulley from the motor drive shaft.
4. While supporting the weight of the drive motor in one hand, loosen and remove (4) mounting bolts
5. Install the replacement motor with hardware kit supplied.
6. Install the pulley per the dimensions in Figure 67 and secure the set screw to the drive shaft
7. Stretch belt over pulley and engage groove.
8. Follow start up procedure on page 61 (procedure needs to be confirmed).

Figure 67: Pulley Installation

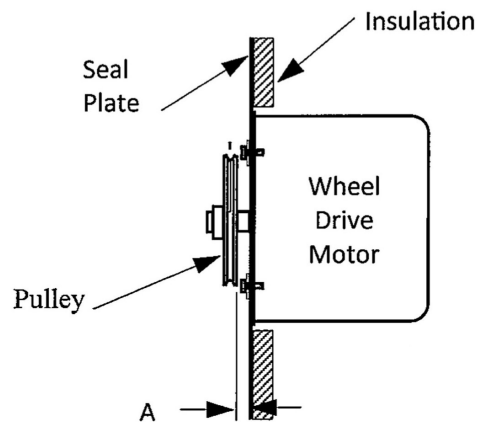

Series	DIM-A
36	1/4"
52	1/4"
64	7/16"
74	7/16"
86	7/16"

## Belt Replacement

1. Obtain access to the pulley side bearing access plate and remove two retaining screws.
2. Using a hexagonal wrench, loosen the screw in the bearing lock collar.
3. Using a light hammer and drift, tap collar in the direction of wheel rotation to unlock collar. Remove collar.
4. Using a socket wrench with extension, remove two nuts which secure bearing housing to the bearing support beam.
5. Slide bearing from shaft.
6. Using a wrench, remove the diameter seal retaining screws. Remove diameter seals from bearing beam.
7. Form a small loop on the belt and pass it through the hole in the bearing support beam. Grasp the belt at the wheel hub and pull the entire belt down. Loop the trailing edge of the belt over the shaft.
8. Install the new belt around the wheel and pulley.
9. Reinstall the bearing onto the wheel shaft, being careful to engage the two locating pins into the holes in the bearing support beam. Secure the bearing with two self locking nuts.
10. Reinstall the diameter seals and tighten retaining screws. See "Diameter Seal Adjustment" on page 61.
11. Reinstall bearing locking collar. Rotate collar by hand in the direction the wheel rotates according to label on wheel cassette. Lock in position by tapping pin hole with hammer and drift. Secure in position with set screw
12. Reinstall bearing access cover with two screws
13. Apply power and ensure wheel rotated freely.

Figure 68: Belt Replacement

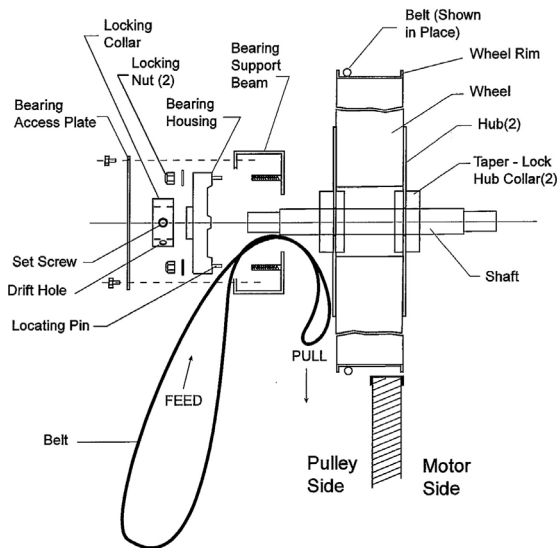

## Troubleshooting

The following table may be used as a quick-reference for identifying common symptoms and possible causes related to the recovery wheel.

Table 21: Energy Recovery Wheel Troubleshooting

Symptom	Cause
Inadequate Wheel Performance	Check wheel rotation speed (see "Variable Frequency Controller" on page 75).
	Check for wheel integrity and adjust seals or replace worn seals (see "Energy Recovery Wheel Design" on page 38 and "Seals" on page 75).
	Check entering air conditions and compare to design (see "Energy Recovery Wheel" on page 61).
	Check ducting for leakage and fix any leaks.
Improper Wheel Rotation	Check media for dirt and clean per cleaning instructions (see "Cleaning" on page 75 and "Segment Installation & Replacement" on page 77).
	Check drive belts for engagement with sheave.
	Check drive motor.
	Check drive motor wiring for proper voltage.
High Pressure Drop	Check VFD programming (provided with optional frost protection).
	Check air flow and compare to design.
	Check filters and clean/replace as necessary.
Noise	Check media for plugging and clean per cleaning instructions (see "Segment Installation & Replacement" on page 77).
	Check seals and adjust as necessary.
	Check the bearings for source of noise.
Wheel Will Not Operate	Check the belt for slippage (see "Drive Belt Tension Adjustment" on page 61).
	Check all electrical connections. If MicroTech II controls are provided, make sure the building pressure is above setpoint such that the EAF turns on. The wheel does not operate unless the EAF is on (see "Exhaust Fan Option" on page 50).

# Supply Fan

## Setscrews

Setscrews are used to lock bearings, sheaves, locking collars, and fan wheels to their shafts. They must be checked periodically to see that they have not loosened. If this is not done, severe equipment damage could occur.

Refer to the values in [Table 22](#) and check the tightness of all setscrews with a torque wrench.

**Table 22: Setscrew Minimum Torque Specifications**

Setscrew Diameter (in.)	Minimum Torque (ft lb)
1/4	5.5
5/16	10.5
3/8	19.0
7/16	29.0
1/2	42.0
5/8	92.0

## Supply Fan Wheel-to-Funnel Alignment

The fan wheel-to-funnel alignment must be as shown in [Figure 69](#) to obtain proper air delivery and operating clearance. If necessary, adjustments are made as follows:

1. Verify that the fan shaft has not moved in its bearings.
2. Loosen the fan hub setscrews and move the wheel(s) along the shaft as necessary to obtain the correct dimension shown in [Table 23](#).
3. Retighten the setscrews to the torque specification given in [Table 22](#). Tighten the setscrews over the keyway first; tighten those at 90 degrees to the keyway last.
4. Verify that the radial clearance around the fan is uniform.

**Figure 69: SWSI Airfoil Wheel-to-Funnel Alignment**

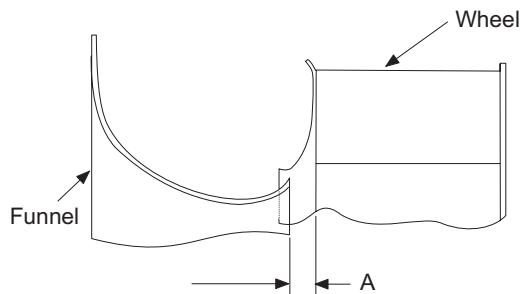

**Table 23: SWSI Airfoil Wheel-to-Funnel Relationship**

Wheel-to-Funnel Relationship (in inches)	
Wheel Diameter	A
15	0.44
18	0.44
20	0.44
22	0.44
24	0.44
30	0.56

## Refrigerant Charge

The unit nameplate references proper charge for each refrigerant circuit in case a full charge must be added to the unit.

Consult "[R-32 Guidelines](#)" on page 63 for details on servicing R-32 (A2L) refrigerant.

**⚠ CAUTION**

**Severe loss of charge may occur if the high refrigerant pressure switch is replaced before reclaiming the refrigerant.** Replace pressure switch after reclaiming refrigerant. Venting refrigerant to atmosphere is not allowed per most local laws and/or codes.

## Servicing Refrigerant Sensors or Switches

The Maverick II includes the following refrigerant sensors or switches.

1. Low refrigerant pressure sensing, operating switch, automatic reset.
  - a. Disables associated compressors on a drop in suction pressure to approximately 35 psig.
  - b. Enables associated compressors on a rise in suction pressure to approximately 60 psig.
2. High refrigerant pressure, protective switch, manual reset at keypad.

The low pressure switch senses refrigerant pressure through schrader fittings that contain cores. The cores are stop valves that do not allow refrigerant to flow through the Schrader unless the device is in place. Therefore, the low pressure switch can be replaced without reclaiming the refrigerant.

The Schrader that serves the high pressure switch does not contain a core in order to maximize the functionality of the safety. Therefore it cannot be replaced unless the refrigerant has already been reclaimed.

# Service / Warranty Procedure

## Replacement Parts

Replacement parts can be obtained by contacting Daikin Applied at 1-800-37-PARTS or at [www.DaikinApplied.com](http://www.DaikinApplied.com). When contacting Daikin Applied for service or replacement parts, refer to the model number and serial number of the unit as stamped on the nameplate attached to the unit.

When contacting Daikin Applied for service or replacement parts, provide the model number, serial number, and unit part number of the unit as stamped on the serial plate attached to the unit. For questions regarding wiring diagrams, provide the number on the specific diagram. If replacement parts are required, include the date of unit installation, the date of failure, an explanation of the malfunction, and a description of the replacement parts required.

## Compressors

### Scroll Compressor

All Daikin Applied Rooftop products include a first-year parts only warranty. The warranty period extends 12 months from startup or 18 months from date of shipment, whichever comes first. Labor to install these parts is not included with this warranty. Compressors are considered a part and are included in this standard warranty.

### All Compressors

Replacement compressors for Daikin Applied Rooftop Units can be obtained from the Daikin Applied Service Parts department.

The decision to replace the failed portion of the compressor tandem, as opposed to replacing the entire tandem, must be decided based on the following.

1. In warranty: Warranty only covers replacement of the failed portion of the tandem.
2. Out of warranty: The customer decides whether to replace the entire tandem or just a portion.
3. Some equipment may include the extended 2nd - 5th year compressor warranty option.

Order the replacement compressor through the Daikin Applied Parts Department (Minneapolis).

1. Contact the Daikin Applied Parts Department for compressor availability.
2. Send a completed parts order form to the Daikin Applied Parts Department.
3. The Parts Department processes the order and the compressors are shipped from our Dayton, OH warehouse via ground transportation. If next-day air is required, indicate this on the parts order form and a freight charge will be billed to your account. Air freight costs are not covered under the Daikin Applied warranty.
4. After the failed compressor is replaced, return it to Daikin Applied with a Return Goods Tag attached, which you will receive in the mail. It must be attached to the compressor. The Return Goods Tag has instructions on where to send the compressor. If the compressor is not returned, you will be billed for the replacement compressor.
5. Consideration may be given at this time to a compressor teardown analysis, depending on the history of failures.

## In-Warranty Return Material Procedure

Material other than compressors may not be returned except by permission of authorized factory service personnel of Daikin Applied at Minneapolis, Minnesota.

A "return goods" tag will be sent to be included with the returned material. Enter the information as called for on the tag in order to expedite handling at our factories and issuance of credits. All parts shall be returned to the factory designated on the return goods tag, transportation charges prepaid.

The return of the part does not constitute an order for replacement. A purchase order for the replacement part must be entered through your nearest Daikin Applied representative. The order should include the component's part number and description and the model and serial numbers of the unit involved.

If it is determined that the failure of the returned part is due to faulty material or workmanship within the standard warranty period, credit will be issued on the customer's purchase order.

# Limited Product Warranty



DAIKIN APPLIED AMERICAS INC.  
LIMITED PRODUCT WARRANTY  
(United States and Canada)

## WARRANTY

Daikin Applied Americas Inc. dba Daikin Applied ("Company") warrants to contractor, purchaser and any owner of the product (collectively "Owner") that, subject to the exclusions set forth below Company, at its option, will repair or replace defective parts in the event any product manufactured by Company, including products sold under the brand name Daikin and used in the United States or Canada, proves defective in material or workmanship within twelve (12) months from initial startup or eighteen (18) months from the date shipped by Company, whichever occurs first. Authorized replacement parts are warranted for the remainder of the original warranty. All shipments of such parts will be made FOB factory, freight prepaid and allowed. Company reserves the right to select carrier and method of shipment. In addition, Company provides labor to repair or replace warranty parts during Company normal working hours on products with rotary screw compressors or centrifugal compressors. Warranty labor is not provided for any other products.

Company must receive the Registration and Startup Forms for products containing motor compressors and/or furnaces within ten (10) days of original product startup, or the ship date and the startup date will be deemed the same for determining the commencement of the warranty period and this warranty shall expire twelve (12) months from that date. For additional consideration, Company will provide an extended warranty(ies) on certain products or components thereof. The terms of the extended warranty(ies) are shown on a separate extended warranty statement.

No person (including any agent, sales representative, dealer or distributor) has the authority to expand the Company's obligation beyond the terms of this express warranty or to state that the performance of the product is other than that published by Company.

## EXCLUSIONS

1. If free warranty labor is available as set forth above, such free labor does not include diagnostic visits, inspections, travel time and related expenses, or unusual access time or costs required by product location.
2. Refrigerants, fluids, oils and expendable items such as filters are not covered by this warranty.
3. This warranty shall not apply to products or parts : (a) that have been opened, disassembled, repaired, or altered, in each case by anyone other than Company or its authorized service representative; (b) that have been subjected to misuse, abuse, negligence, accidents, damage, or abnormal use or service; (c) that have not been properly maintained; (d) that have been operated or installed, or have had startup performed, in each case in a manner contrary to Company's printed instructions; (e) that have been exposed, directly or indirectly, to a corrosive atmosphere or material such as, but not limited to, chlorine, fluorine, fertilizers, waste water, urine, rust, salt, sulfur, ozone, or other chemicals, contaminants, minerals, or corrosive agents; (f) that were manufactured or furnished by others and/or are not an integral part of a product manufactured by Company; or (g) for which Company has not been paid in full.
4. This warranty shall not apply to products with rotary screw compressors or centrifugal compressors if such products have not been started, or if such startup has not been performed, by a Daikin Applied or Company authorized service representative.

## SOLE REMEDY AND LIMITATION OF LIABILITY

THIS WARRANTY CONSTITUTES THE SOLE WARRANTY MADE BY COMPANY. COMPANY'S LIABILITY TO OWNER AND OWNER'S SOLE REMEDY UNDER THIS WARRANTY SHALL NOT EXCEED THE LESSER OF: (i) THE COST OF REPAIRING OR REPLACING DEFECTIVE PRODUCTS; AND (ii) THE ORIGINAL PURCHASE PRICE ACTUALLY PAID FOR THE PRODUCTS. COMPANY MAKES NO REPRESENTATION OR WARRANTY, EXPRESS OR IMPLIED, REGARDING PREVENTION OF MOLD/MOULD, FUNGUS, BACTERIA, MICROBIAL GROWTH, OR ANY OTHER CONTAMINATES. THIS WARRANTY IS GIVEN IN LIEU OF ALL OTHER WARRANTIES, INCLUDING, WITHOUT LIMITATION, THE IMPLIED WARRANTIES OF MERCHANTABILITY, FITNESS FOR A PARTICULAR PURPOSE, AND NON-INFRINGEMENT, WHICH ARE HEREBY DISCLAIMED. IN NO EVENT AND UNDER NO CIRCUMSTANCE SHALL COMPANY BE LIABLE TO OWNER OR ANY THIRD PARTY FOR INCIDENTAL, INDIRECT, SPECIAL, CONTINGENT, CONSEQUENTIAL, DELAY OR LIQUIDATED DAMAGES FOR ANY REASON, ARISING FROM ANY CAUSE WHATSOEVER, WHETHER THE THEORY FOR RECOVERY IS BASED IN LAW OR IN EQUITY, OR IS UNDER A THEORY OF BREACH CONTRACT OR WARRANTY, NEGLIGENCE, STRICT LIABILITY, OR OTHERWISE. THE TERM "CONSEQUENTIAL DAMAGE" INCLUDES, WITHOUT LIMITATION, THOSE DAMAGES ARISING FROM BUSINESS INTERRUPTION OR ECONOMIC LOSS, SUCH AS LOSS OF ANTICIPATED PROFITS, REVENUE, PRODUCTION, USE, REPUTATION, DATA OR CROPS.

## ASSISTANCE

To obtain assistance or information regarding this warranty, please contact your local sales representative or a Daikin Applied office.

Form No. 933-430285Y-01-A (11/2023)  
Part No. 043028500 Rev.0F

# Warranty Registration Form



## Rooftop Equipment Warranty Registration Form

To comply with the terms of Daikin Applied Warranty, register start date and upload this form within 10 days to the Warranty Department of Daikin Applied.

Check, test, and start procedure for Rooftop roof mounted air conditioners with or without heat recovery and roof mounted air handlers.

### GENERAL INFORMATION

Job Name: \_\_\_\_\_ Unit No.: \_\_\_\_\_

SOI No.: \_\_\_\_\_

Installation address: \_\_\_\_\_

City: \_\_\_\_\_ State: \_\_\_\_\_

Purchasing contractor: \_\_\_\_\_

City: \_\_\_\_\_ State: \_\_\_\_\_

Name of person doing start-up: \_\_\_\_\_

Company name: \_\_\_\_\_

Address: \_\_\_\_\_

City/State/Zip: \_\_\_\_\_

### UNIT INFORMATION

Unit model number: \_\_\_\_\_ Unit serial number: \_\_\_\_\_

Compressor 1 model number: \_\_\_\_\_ Serial number: \_\_\_\_\_

Compressor 2 model number: \_\_\_\_\_ Serial number: \_\_\_\_\_

Compressor 3 model number: \_\_\_\_\_ Serial number: \_\_\_\_\_

Compressor 4 model number: \_\_\_\_\_ Serial number: \_\_\_\_\_

Compressor 5 model number: \_\_\_\_\_ Serial number: \_\_\_\_\_

Compressor 6 model number: \_\_\_\_\_ Serial number: \_\_\_\_\_



Rooftop Equipment Warranty Registration Form (continued)

Select Yes or No. If not applicable to the type of unit, select N/A.

I. INITIAL CHECK

- A. Is any shipping damage visible? . . . . .  Yes  No  N/A
- B. Are fan drives properly aligned and belts properly adjusted? . . . . .  Yes  No  N/A
- C. Tightened all setscrews on pulleys, bearings and fans? . . . . .  Yes  No  N/A
- D. Have the hold-down bolts been backed off on spring mounted fan isolators? . . . . .  Yes  No  N/A
- E. Do fans turn freely? . . . . .  Yes  No  N/A
- F. Has the discharge static pressure reference line been properly located within the building? . . . . .  Yes  No  N/A
- G. Electrical service corresponds to unit nameplate? . . . . .  Yes  No  N/A

G1. Voltage at Terminal Block | Disconnect                      1-2 \_\_\_\_\_ V    2-3 \_\_\_\_\_ V    1-3 \_\_\_\_\_ V

- H. Is the main disconnect adequately fused and are fuses installed? . . . . .  Yes  No  N/A
- I. Are crankcase heaters operating, and have they been operating 24 hours prior to start-up? . . . . .  Yes  No  N/A
- J. Are all electrical power connections tight? (Check compressorelectrical box.) . . . . .  Yes  No  N/A
- K. Is the condensate drain trapped? . . . . .  Yes  No  N/A

II. FAN DATA

- A. Check rotation of supply fan? . . . . .  Yes  No  N/A
- B. Voltage at supply fan motor: . . . . . 1-2 \_\_\_\_\_ V    2-3 \_\_\_\_\_ V    1-3 \_\_\_\_\_ V
- C. Supply fan motor amp draw per phase: . . . . . L1 \_\_\_\_\_ L2 \_\_\_\_\_ L3 \_\_\_\_\_
- D. Fuse sizes: . . . . . \_\_\_\_\_
- E. What is the supply fan rpm? . . . . . \_\_\_\_\_
- F. Check rotation of return fan? . . . . .  Yes  No  N/A
- G. Voltage at return fan motor: . . . . . 1-2 \_\_\_\_\_ V    2-3 \_\_\_\_\_ V    1-3 \_\_\_\_\_ V
- H. Return fan motor amp draw per phase: . . . . . L1 \_\_\_\_\_ L2 \_\_\_\_\_ L3 \_\_\_\_\_
- I. Fuse sizes: . . . . . \_\_\_\_\_
- J. What is the return fan rpm? . . . . . \_\_\_\_\_
- K. Record supply static pressure at unit in inches of H<sub>2</sub>O: . . . . . \_\_\_\_\_
- L. Record return static pressure at unit (with outside air dampers closed) in inches of H<sub>2</sub>O: . . . . . \_\_\_\_\_



Rooftop Equipment Warranty Registration Form (continued)

Select Yes or No. If not applicable to the type of unit, select N/A.

III. START-UP COMPRESSOR OPERATION

A. Do compressors have holding charges?

Circuit #1. . . . .  Yes  No  N/A

Circuit #2. . . . .  Yes  No  N/A

B. Are compressors rotating in the right direction? . . . . .  Yes  No  N/A

C. Do condenser fans rotate in the right direction? . . . . .  Yes  No  N/A

D. Ambient temperature (°F): . . . . . \_\_\_\_\_

E. Does unit start up and perform per sequence of operation? . . . . .  Yes  No  N/A

IV. PERFORMANCE DATA

A. Compressor voltage across each phase: . . . . . 1-2 \_\_\_\_\_ V 2-3 \_\_\_\_\_ V 1-3 \_\_\_\_\_ V

B. Compressor amperage of fully loaded compressor: Compressor #1 — Phase 1 \_\_\_\_\_ Phase 2 \_\_\_\_\_ Phase 3 \_\_\_\_\_

Compressor #2 — Phase 1 \_\_\_\_\_ Phase 2 \_\_\_\_\_ Phase 3 \_\_\_\_\_

Compressor #3 — Phase 1 \_\_\_\_\_ Phase 2 \_\_\_\_\_ Phase 3 \_\_\_\_\_

Compressor #4 — Phase 1 \_\_\_\_\_ Phase 2 \_\_\_\_\_ Phase 3 \_\_\_\_\_

Compressor #5 — Phase 1 \_\_\_\_\_ Phase 2 \_\_\_\_\_ Phase 3 \_\_\_\_\_

Compressor #6 — Phase 1 \_\_\_\_\_ Phase 2 \_\_\_\_\_ Phase 3 \_\_\_\_\_

C. Low pressure cut-out: . . . . . Circuit 1 \_\_\_\_\_ psig Circuit 2 \_\_\_\_\_ psig

D. Low pressure cut-in: . . . . . Circuit 1 \_\_\_\_\_ psig Circuit 2 \_\_\_\_\_ psig

E. High pressure cut-out: . . . . . Circuit 1 \_\_\_\_\_ psig Circuit 2 \_\_\_\_\_ psig

F. Discharge pressure, one compressor: . . . . . Circuit 1 \_\_\_\_\_ psig Circuit 2 \_\_\_\_\_ psig

G. Discharge pressure, fully loaded, 2-3 compressors: . . . . . Circuit 1 \_\_\_\_\_ psig Circuit 2 \_\_\_\_\_ psig

H. Suction pressure, one compressor: . . . . . Circuit 1 \_\_\_\_\_ psig Circuit 2 \_\_\_\_\_ psig

I. Suction pressure, fully loaded, 2-3 compressors: . . . . . Circuit 1 \_\_\_\_\_ psig Circuit 2 \_\_\_\_\_ psig

J. Liquid press, fully loaded, 2-3 compressors (at liquid line shutoff valve): . . . . . Circuit 1 \_\_\_\_\_ psig Circuit 2 \_\_\_\_\_ psig

K. Liquid temperature, fully loaded, 2-3 compressors: . . . . . Circuit 1 \_\_\_\_\_ psig Circuit 2 \_\_\_\_\_ psig

L. Suction line temperature: . . . . . \_\_\_\_\_ °F \_\_\_\_\_ °F

M. Superheat: . . . . . \_\_\_\_\_ °F \_\_\_\_\_ °F

N. Subcooling: . . . . . \_\_\_\_\_ °F \_\_\_\_\_ °F

O. Is the liquid in the line sightglass clear and dry? . . . . .  Yes  No  N/A

P. Does the hot gas bypass valve function properly? . . . . .  Yes  No  N/A



Rooftop Equipment Warranty Registration Form (continued)

Select Yes or No. If not applicable to the type of unit, select N/A.

- Q. At what suction pressure does the hot gas bypass valve open? . . . . . Circuit 1 \_\_\_\_\_ psig Circuit 2 \_\_\_\_\_ psig
R. Record discharge air temperature at discharge of unit: \_\_\_\_\_ °F
S. Are all control lines secure to prevent excessive vibration and wear? . . . . .  Yes  No  N/A
T. Are all gauges shut off and valve caps and packings tight after start-up? . . . . .  Yes  No  N/A

V. ELECTRIC HEAT CHECK, TEST & START

- A. Electrical heat service corresponds to unit nameplate? . . . . .  Yes  No  N/A
Volts \_\_\_\_\_ Hertz \_\_\_\_\_ Phase \_\_\_\_\_
B. Are there any signs of physical damage to the electric heat coils? . . . . .  Yes  No  N/A
C. Have all electrical terminals been tightened? . . . . .  Yes  No  N/A
D. Does sequence controller stage contactors properly? . . . . .  Yes  No  N/A
E. Electric heater voltage across each phase: . . . . . \_\_\_\_\_ L1 \_\_\_\_\_ L2 \_\_\_\_\_ L3
F. Amp draw across each phase at each heating stage:
Stage 1 Stage 2 Stage 3 Stage 4 Stage 5 Stage 6
Phase L1: \_\_\_\_\_
Phase L2: \_\_\_\_\_
Phase L3: \_\_\_\_\_
G. FLA: . . . . . L1 \_\_\_\_\_ L2 \_\_\_\_\_ L3 \_\_\_\_\_
H. Operate electric heat with fans off. Electric heat must cycle on high limit control . . . . .  Yes  No  N/A

VI. GAS BURNER CHECK, TEST, & START

Specifications:

For gas, see Forced Draft Gas Burner Installation and Maintenance Bulletin. (IM 684 and IM 685)

- A. Gas Furnace: . . . . . Model no. \_\_\_\_\_
B. Gas Burner: . . . . . Model no. \_\_\_\_\_ Serial no. \_\_\_\_\_
C. Gas Rated firing rate (MBH input): . . . . . \_\_\_\_\_
D. Gas Altitude (ft. above sea level): . . . . . \_\_\_\_\_
E. Input (CFH): . . . . . \_\_\_\_\_
F. Gas pressure at burner (inches w.c.): . . . . . \_\_\_\_\_
G. CO2 (%): . . . . . \_\_\_\_\_
H. CO2 (%): . . . . . \_\_\_\_\_
I. Pilot flame only in microamps (steady at low fire): . . . . . \_\_\_\_\_
J. Pilot Tap-gas pressure (inches w.c.): . . . . . \_\_\_\_\_
K. Motor only/burner FLA running amps: . . . . . \_\_\_\_\_
L. High limit control OK? . . . . .  Yes  No  N/A
M. Flame safeguard (microamps): . . . . . \_\_\_\_\_



Rooftop Equipment Warranty Registration Form (continued)

Select Yes or No. If not applicable to the type of unit, select N/A.

N. Flame failure shutoff (seconds): . . . . . \_\_\_\_\_

O. Airswitch OK? . . . . .  Yes  No  N/A

P. High Gas Pressure Switch OK? . . . . .  Yes  No  N/A

Q. Low Gas Pressure Switch OK? . . . . .  Yes  No  N/A

R. Main Gas Valve Close-off OK? . . . . .  Yes  No  N/A

S. Modulation Gas Heat Performance

**Gas Pressure**

**Mod. Valve** \_\_\_\_\_ **Reg. Valve** \_\_\_\_\_

25% \_\_\_\_\_ in Wc. 25% \_\_\_\_\_ in Wc.

50% \_\_\_\_\_ in Wc. 50% \_\_\_\_\_ in Wc.

75% \_\_\_\_\_ in Wc. 75% \_\_\_\_\_ in Wc.

100% \_\_\_\_\_ in Wc. 100% \_\_\_\_\_ in Wc.

**VII. Hot Water Coil**

A. Pressure test OK? . . . . .  Yes  No  N/A

**VIII. Heat Recovery**

A. Heat wheel rotates freely? . . . . .  Yes  No  N/A

B. Heat wheel VFD operates properly? . . . . .  Yes  No  N/A

C. Heat wheel VFD . . . . . Model No. \_\_\_\_\_ Serial No. \_\_\_\_\_

D. Check for air bypass around heat wheel. . . . .  Yes  No  N/A

**IX. Design Flow Calibration**

A. Verify power is supplied to the MicroTech III unit controller . . . . .  Yes  No  N/A

B. Verify that the shipping screws have been removed from the measuring station vane . . . . .  Yes  No  N/A

C. Examine station for damage . . . . .  Yes  No  N/A

D. Record Level Position after calibration

• LH Level Position . . . . . \_\_\_\_\_

• RH Level Position . . . . . \_\_\_\_\_

NOTE: This is viewed in the MicroTech III controller, in the Min OA setup menu.



Rooftop Equipment Warranty Registration Form (continued)

Select Yes or No. If not applicable to the type of unit, select N/A.

X. Have all electronic or electrical controls been checked, adjusted, and tested for proper operation per the installation and maintenance bulletins?

.....  Yes  No  N/A

XI. MAINTAINING MICROTECH CONTROL PARAMETER RECORDS

After the unit is checked, tested, and started and the final control parameters are set, record the final settings. Keep these records on file and update whenever changes to the control parameters are made. Keeping a record facilitates any required analysis and troubleshooting of the system operation and facilitates restoration after a controller replacement.

Thank you for completing this form. Please sign and date below.

Signature \_\_\_\_\_ Startup date: \_\_\_\_\_

Register equipment start date and upload form on the Daikin Applied FieldCare Portal at <https://fieldcare.daikinapplied.com>

Please fill out the Daikin Applied "Quality Assurance Survey Report" and list any additional comments that could affect the operation of this unit; e.g., shipping damage, failed components, adverse installation applications, etc. If additional comment space is needed, write the comment(s) on a separate sheet, attach it to the Survey Report and return it to the Warranty Department of Daikin Applied with the completed Equipment Warranty Registration form.

Clear Form



### Quality Assurance Survey Report

To whom it may concern:  
Please review the items below upon receiving and installing our product. Select N/A on any item that does not apply to the product.

Job Name: \_\_\_\_\_ Daikin Applied S.O. No. \_\_\_\_\_

Installation address: \_\_\_\_\_

City: \_\_\_\_\_ State: \_\_\_\_\_

Purchasing contractor: \_\_\_\_\_

City: \_\_\_\_\_ State: \_\_\_\_\_

Name of person doing start-up (print): \_\_\_\_\_

Company name: \_\_\_\_\_

Address: \_\_\_\_\_

City/State/Zip: \_\_\_\_\_

Unit model number: \_\_\_\_\_ Unit serial number: \_\_\_\_\_

1. Is there any shipping damage visible? ..... Yes  No  N/A

Location on unit \_\_\_\_\_

2. How would you rate the overall appearance of the product; i.e., paint, fin damage, etc.?  
Excellent  Good  Fair  Poor

3. Did all sections of the unit fit together properly? ..... Yes  No  N/A

4. Did the cabinet have any air leakage? ..... Yes  No  N/A

Location on unit \_\_\_\_\_

5. Were there any refrigerant leaks? ..... Yes  No  N/A

From where did it occur? ..... Shipping  Workmanship  Design

6. Does the refrigerant piping have excessive vibration? ..... Yes  No  N/A

Location on unit \_\_\_\_\_

7. Did all of the electrical controls function at start-up? ..... Yes  No  N/A

Comments \_\_\_\_\_

8. Did the labeling and schematics provide adequate information? ..... Yes  No  N/A

9. How would you rate the serviceability of the product?  
Excellent  Good  Fair  Poor

10. How would you rate the overall quality of the product?  
Excellent  Good  Fair  Poor

11. How does the quality of Daikin Applied products rank in relation to competitive products?  
Excellent  Good  Fair  Poor

Comments \_\_\_\_\_

Please list any additional comments which could affect the operation of this unit; i.e., shipping damage, failed components, adverse installation applications, etc. If additional comment space is needed, write the comment(s) on a separate sheet, attach the sheet to this completed Quality Assurance Survey Report, and return it to the Warranty Department with the completed preceding "Equipment Warranty Registration Form".



# COMPLETE HVAC SYSTEM SOLUTIONS

SELF-CONTAINED | ROOFTOPS | COILS | CONDENSING UNITS  
AIR HANDLERS | WATER-COOLED CHILLERS | AIR-COOLED CHILLERS  
MODULAR CENTRAL PLANTS | CONNECTED BUILDING CONTROLS  
UNIT HEATERS | FAN COILS | AIR PURIFIERS | WATER SOURCE HEAT PUMPS  
VARIABLE AIR VOLUME UNITS | UNIT VENTILATORS



13600 INDUSTRIAL PARK BLVD. | MINNEAPOLIS, MN 55441  
1-800-432-1342 | 763-553-5330

LEARN MORE AT  
**DAIKINAPPLIED.COM**

PART NUMBER: IM1390

© 2026 DAIKIN APPLIED | (800) 432.1342 | WWW.DAIKINAPPLIED.COM