



INSTALLATION & MAINTENANCE

IM 915-17

MARCH 2026

# VISION® AIR HANDLER EXTENDED SIZES



- HEATING AND COOLING
- R410A, R32, OR R454B REFRIGERANT
- MODELS: CAH OR CAC
- UNIT SIZES AT LEAST 144" IN WIDTH

# Table of Contents



<b>General Information</b> .....	<b>3</b>	<b>Operation Guidelines</b> .....	<b>29</b>
Compliance Statements .....	4	Startup Checks .....	29
Unit Labels .....	5	<b>Daikin Applied Fan Array</b> .....	<b>33</b>
Receiving and Handling .....	5	<b>Daikin Applied ECM Fan Array</b> .....	<b>36</b>
Unit Storage .....	6	Fan Vibration Levels .....	42
Gas Furnace .....	6	Fan Operating Limits .....	43
<b>Installation Guidelines</b> .....	<b>7</b>	<b>Gas Phase Filtration Technology</b> .....	<b>44</b>
Service Clearances .....	7	<b>Electric and Gas Heat</b> .....	<b>45</b>
Lifting Guidance .....	7	<b>A2L Refrigerant Guidelines (if applicable)</b> .....	<b>47</b>
Transit and Temporary Storage .....	8	Minimum Room Area .....	48
Unit Leveling .....	9	<b>Service and Maintenance</b> .....	<b>60</b>
Assembling Sections .....	9	Periodic Service and Maintenance .....	60
Holding Frame, Filter, and Prefilter Installation .....	14	Front Load Filter Option .....	62
Piping and Coils .....	19	<b>Warranty Procedure</b> .....	<b>67</b>
Internal Fan Isolation Assembly Adjustment .....	26	<b>Limited Warranty</b> .....	<b>68</b>
<b>Electrical Installation</b> .....	<b>28</b>	<b>Warranty Registration Form</b> .....	<b>69</b>
Wiring .....	28	<b>Quality Assurance Survey Report</b> .....	<b>75</b>


©2026 Daikin Applied, Minneapolis, MN. All rights reserved throughout the world. This document contains the most current product information as of this printing. Daikin Applied Americas Inc. has the right to change the information, design, and construction of the product represented within the document without prior notice. For the most up-to-date product information, please go to [www.DaikinApplied.com](http://www.DaikinApplied.com).

™® Vision, MicroTech, and Daikin Applied are trademarks or registered trademarks of Daikin Applied Americas Inc. The following are trademarks or registered trademarks of their respective companies: BACnet from American Society of Heating, Refrigerating and Air-Conditioning Engineers, Inc.; Echelon, LonWorks, LonMark, and LonTalk from Echelon Corporation; Modbus from Schneider Electric; and Windows from Microsoft Corporation.



## A2L Refrigerants (if applicable)

 <b>WARNING</b>	
	<p><b>A2L</b></p> <p>This unit contains either R-32 or R-454b. Both are class A2L refrigerants that are flammable. This unit should only be installed, serviced, repaired, and disposed of by qualified personnel licensed or certified in their jurisdiction to work with A2L refrigerants. Installation and maintenance must be done in accordance with this manual. Improper handling of this equipment can cause equipment damage, personal injury, or equipment damage.</p>
<p>Be aware that R-32 and R-454b refrigerant may not contain an odor. Place in a well ventilated area to prevent accumulation of refrigerant. When installing the unit in a small room, take measures to keep the refrigerant concentration from exceeding allowable safety limits. Excessive refrigerant leaks, in the event of an accident in a closed ambient space, can lead to oxygen deficiency.</p> <p>Do not pierce or burn this unit.</p> <p>Never use an open flame during service or repair. Never store in a room with continuously operating ignition sources (for example: open flames, an operating gas appliance, or an operating electric heater.), where there is ignitable dust suspension in the air, or where volatile flammables such as thinner or gasoline are handled.</p> <p>Only use pipes, nuts, and tools intended for exclusive use with the unit's designated A2L refrigerant in compliance with national codes (ASHRAE15 or IRC).</p> <p>Do not mix air or gas other than the unit's designated A2L refrigerant in the refrigerant system. If air enters the refrigerant system, an excessively high pressure results, which may cause equipment damage or personal injury.</p> <p>Do not use means to accelerate the defrosting process or to clean, other than those recommended by the manufacturer.</p> <p>The unit shall be stored in a room without continuously operating ignition sources (for example: open flames, an operating gas appliance, or an operating electric heater).</p>	

 <b>WARNING</b>	
<p>When moving flammable A2L refrigerant to/from the unit from an auxiliary tank, a grounding strap must be used. An electrical charge builds when halo-carbon refrigerant travels in a rubber hose. A grounding strap must be used between the auxiliary refrigerant tank and the unit's end sheet (earth ground), which will safely take the charge to the ground. A fire risk could occur if this procedure is not followed.</p>	

## Unit Nameplate

The unit nameplate is located on the outside of the main control box door. It includes the unit model number, serial number, electrical characteristics, and refrigerant charge.

## Compliance Statements







Depending on the unit configuration, the unit will come with either a Fused Disconnect, a Non-Fused Disconnect, a power block, or a combination in cases where multiple sources of power are specified. Consult the Unit Specific Electrical Schematics to determine the number of required sources of power. Refer to [See Electrical Installation on page 28](#) for the standard multiple point power connection options and their function.

This appliance is not intended for use by persons (including children) with reduced physical, sensory, or mental capabilities, or lack of experience and knowledge, unless they have been given supervision or instruction concerning use of the appliance by a person responsible for their safety.

NOTICE
<p>Unit/equipment must be installed in a location that is not accessible to the general public.</p>

## Unit Labels

Pictogram warning and informational labels may be present on the unit. Consult the table below for reference.

Label	Description
 <p>Refrigerant class per ISO 817</p>	<b>WARNING - flammable refrigerant present</b>
	Read the technical manual for service instructions
	WARNING - A2L low-burning velocity refrigerant present
	Pressurized medium present
	Ultraviolet (UV) radiation present
	Read the technical manual for instructions

## Receiving and Handling

### Inspection

Carefully check equipment against the bill of lading to ensure all items have been received. Before unloading any unit, check the nameplate to make sure the voltage complies with the power supply available.

Inspect all units for damage upon arrival. If a unit has become dirty during shipment, carefully clean it prior to completing the inspection. Daikin Applied is not responsible for physical damage after the unit leaves the factory unless the contract with Daikin Applied states otherwise.

### NOTICE

All units should be carefully inspected for damage when received. Report all loss or shipping damage using a claim form supplied by Daikin Applied.

**VISIBLE LOSS OR DAMAGE:** Any external evidence of loss or damage must be noted on the freight bill or carrier's receipt, and signed by the carrier's agent. Failure to adequately describe such external evidence of loss or damage may result in the carrier's refusal to honor a damage claim.

**CONCEALED LOSS OR DAMAGE:** Concealed loss or damage means loss or damage which does not become apparent until the unit has been unpacked or unwrapped. The contents may be damaged in transit due to rough handling even though the exterior may not show damages. When the damage is discovered, make a written request for inspection by the carrier's agent within **five (5) days** of the delivery date and file a claim with the form provided by Daikin Applied. Refer to the Daikin Applied Freight Policy for further information.

### Packaging

- All shipping wrap material, including stretch and shrink wrap, must be removed upon unit arrival. This wrapping is for transit protection only. Units are not to be stored with wrapping material left on, as white rust will develop if any moisture is present.
- Field-installed components will ship on separate skid(s).
- Hardware (screws, bolts, etc.) for assembling sections are supplied in a bag attached to each section. All necessary gasketing is applied in the factory for section-to-section mounting.

**NOTE:** A special #30 Torx bit is required for assembly.

### Identification

- Every shipping section includes a nameplate identifying the customer tagging information, unit serial number, unit order number, and the shipping section position for installation.

## Handling

- Vision air handler units are constructed of painted or galvanized steel and are inspected thoroughly before leaving the factory. Take care during installation to prevent damage to units. Do not stand or walk on top of units.
- Air handler bases are designed with the necessary number of lifting points for safe installation. All lifting locations must be used.
- Take special care when handling blower sections. All fans are dynamically balanced before leaving the factory. Rough handling can cause misalignment or a damaged bearings or shaft. Carefully inspect fans and shaft before unit installation to verify this has not happened.
- Handle the zone damper of the multi-zone units with special care. Zone dampers are set and inspected before leaving the factory but should be checked on arrival to the job to verify the bell arm and connecting rod set screws did not become loose in shipment.

## Unit Storage

- Ensure no moisture, debris, or minerals are on the unit prior to storage, as these can cause permanent damage to the cabinet and components.
- Store units in a clean, dry environment on a level surface. Ensure units are on a dry surface or raised off the ground to protect components from any standing water; ensure adequate support is used to prevent the unit or section base from sagging, if raised.
- All openings, including dampers and bottom openings, must be covered to protect from rain, snow, dust, and animals. Do not use plastic tarps to cover the unit, as condensation can form on the air handler resulting in corrosion or stains. Use only canvas tarps to ensure the inside of the unit remains clean, dry, and ventilated. Do not allow coverings to trap moisture on surfaces.
- All tarps should be inspected frequently to ensure the integrity of the tarp is maintained and to prevent damage to the unit by the elements. Any damage to the tarp should be repaired immediately.
- It is recommended that the unit interior be inspected daily to observe whether condensation is occurring and if temporary or routine ventilation of the interior is needed to control condensation. Units should be inspected at different times of the day to ensure varying weather conditions are not causing condensate to occur.
- All shipping wrap material, including stretch and shrink wrap, must be removed upon unit arrival. Units are not to be stored with wrapping material left on, as white rust will develop if any moisture is present.
- A field-supplied desiccant bag may be hung in the interior of the unit to minimize corrosion in humid storage environments.
- Do not stack sections or store anything on top of units.
- Isolate unit from shock and vibration.
- Do not clean galvanized steel surfaces with oil dissolving

chemicals. This may remove the protective coating and accelerate corrosion.

- Pack fan and motor bearings (unless motor bearings are sealed) with compatible grease while the fan shaft is stationary. After grease has been installed, rotate shaft a minimum of 10 rotations.
- Once a month, rotate shaft a minimum of 10 revolutions. Ensure the stopped position is different than the original position.
- Coat shafts with lubricant as needed to prevent corrosion.
- Inspect all doors and openings once a month to ensure they are closed and properly sealed.
- Loosen belt tension on belt-driven fans, if storing for more than two (2) months.

## Belt driven fans:

- Reduce belt tension by at least 50% or remove the belts. Remove belts if they will be subjected to temperatures exceeding 85°F (29°C) to avoid deterioration.
- Remove belt guard when adjusting belts.
- Reduce belt tension prior to removing or installing belts. Removing or installing tensioned belts may cause personal injury and damage to the sheaves, belts, bearings or shafts.
- Adjustable sheaves should be opened as wide as possible and the adjustment threads lubricated so they do not corrode. Be careful not to put lubricant on the belt running surface.

## Prior to start up:

- Set screws on bearings, fan wheels, and sheaves need to be checked for proper torque. Also check bolt torque for any taper lock hubs either on the wheel or sheaves.
- Check sheaves for corrosion. Significant corrosion can cause belt or sheave failure.
- Purge old grease from fan bearings while rotating the shaft to distribute the new grease evenly and prevent bearing seal failure.
- Correctly align and tension belts. [See General Rules of Tensioning on page 61.](#)

## Gas Furnace

For installation and maintenance information related to gas heat, refer to [IM 1300](#).

# Installation Guidelines

## Service Clearances

In addition to providing adequate space around the unit for piping coils and drains, access to at least one side of the unit is always required to allow for regular service and routine maintenance, which includes filter replacement, drain pan inspection and cleaning, fan bearing lubrication, and belt adjustment. Provide sufficient space—at least equal to the length of the coil—on the side of the unit for shaft removal and coil removal. Space, at least equal to the length of the side coil, is required for coil removal. Space, at least equal to the fin height, is required for top coil removal. See Figure 1 for servicing space requirements.

For routine maintenance purposes, access normally is obtained through the access doors or by removing panels. Fan and filter sections are always provided with a service door on one side of the unit. If requested, doors can be provided on both sides of the unit. Optional service doors are available for most section types and are provided based on customer request.

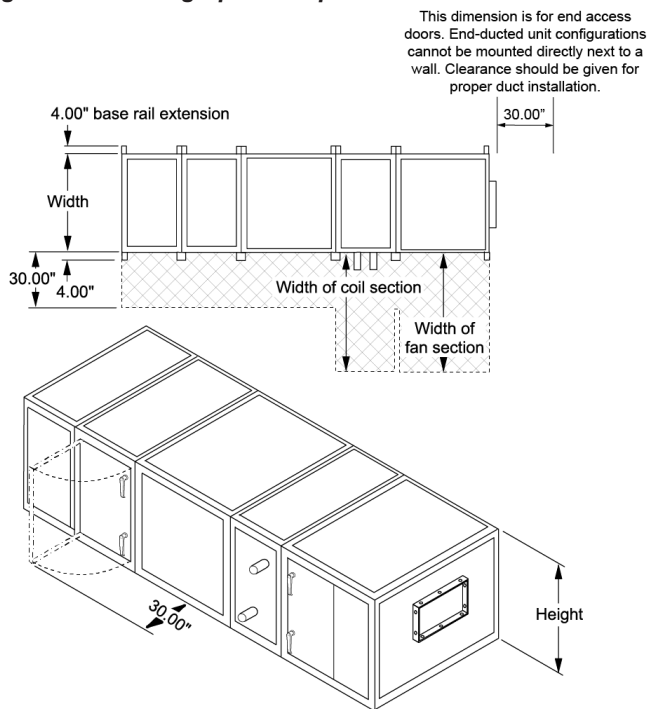
If component replacement is required, the top panel also can be removed. If necessary, the unit can be disassembled.

### NOTICE

Verify local codes regarding clearances in front of electrical devices.

Supplementary heaters are suitable for installation with zero spacing between the duct and combustible surfaces

Figure 1: Servicing Space Requirements



## Lifting Guidance

Daikin Applied equipment is designed to withstand the loads of the lifting and rigging process resulting from ASME Standard P30.1 - Planning for Load Handling Activities or equivalent. Lifting guidance is intended for installations of newly delivered equipment. If moving previously installed equipment for re-location or disposal, consideration should be given to unit condition. Equipment should also be drained as unit weight and center of gravity values do not reflect the addition of water for lifting.

### ⚠ DANGER

Improper rigging, lifting, or moving of a unit can result in unit damage, property damage, severe personal injury, or death. See the as-designed, certified dimensioned drawings included in the job submittal for the weights and center of gravity of the unit. If the drawings are not available, consult the local Daikin Applied sales office for assistance.

Installation is to be performed only by qualified personnel who are familiar with local codes and regulations, and experienced with this type of equipment. Lifting equipment and mechanisms must be determined by the Lifting Director per the current version of ASME Standard P30.1 or equivalent and must be suited for the load capacity. Daikin Applied is not a licensed nor certified rigging specialist. Therefore it is the customer's responsibility to consult a certified rigging contractor to rig, lift, and move components and subcomponents properly and safely as needed.

### ⚠ CAUTION

Forklifts may not be used to lift or move ship sections as the method may result in unit damage.

### ⚠ CAUTION

When around sharp edges, wear appropriate Personal Protective Equipment (PPE), such as gloves, protective clothing, foot wear, eye protection, etc., to prevent personal injury.

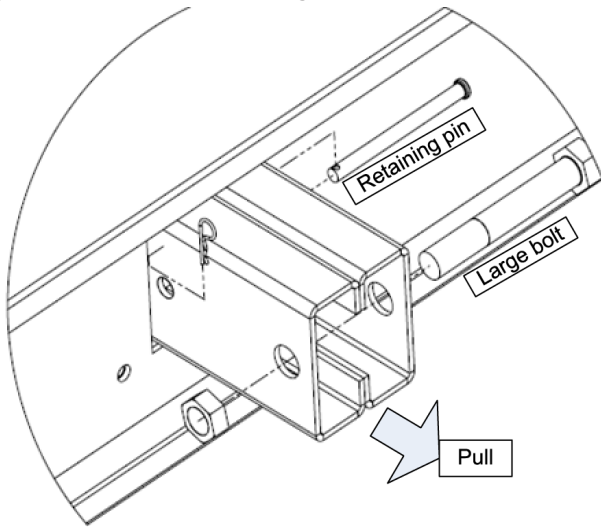
## Lifting Brackets

Lifting brackets on Vision Extended ship sections are located on the air entering and leaving faces and are either retractable or removable.

The large bolt included can be removed or used to facilitate the chosen lifting equipment.

Engagement with each bracket is to be as close to vertical as possible. The maximum allowable lift angle from the vertical is 30 degrees as shown in Figure 3. If the lift angle shifts beyond 30 degrees from vertical on any of the lift points, the lift shall not proceed until a plan and rigging can be secured that will correct the angle of lift.

Figure 2: Illustration of Lifting Brackets



**WARNING**  
 The lifting angle must not go beyond 30 degrees from vertical or the unit can become unstable which may result in unit damage, property damage, severe personal injury, or death.

Figure 3: Illustration of Allowed Angle Label

**WARNING**

**All factory provided lifting points must be used. Unit must remain level during lift and transit!**

The lifting strap angle must not go beyond 30 degrees from vertical or the unit can become unstable which may result in unit damage, property damage or severe personal injury or death.

### Lifting Equipment

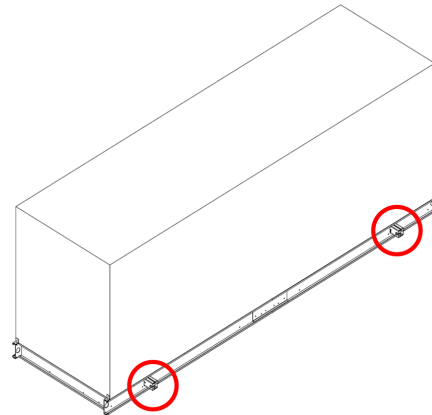
Lifting equipment is supplied by the user or their designate. This is typically selected around the unit certified information of the equipment to be lifted and the available lifting equipment planned to be at the site where the lift is to take place. It is the responsibility of the Lifting Director to follow a standard practice of lift planning and equipment selection, like that found in the ASME P30 series of standards. Lifting plan and equipment must ensure that the only contact with the unit is at that lifting brackets. Straps, chains or spreader bars that are likely to be used shall not come in contact with the unit.

**CAUTION**  
 Lifting mechanisms must not make contact with the unit beyond the lifting bracket. Extreme care must be used when rigging the unit to prevent damage to the control panels, unit handles, unit piping, and unit frame.

### Lifting Points

Lifting points are predetermined by design. When lifting, all factory installed lifting brackets must be used. Unit must remain level throughout the entire lifting event. Level is defined as one end being no more than 0.25" per foot of unit length to the opposite end.

Figure 4: Typical Lifting Points



**WARNING**  
 Be aware that the center of gravity may not necessarily be in the geometric center of the unit. No additional items can be added to a lift with the unit as it may affect the center of gravity and cause unit damage, property damage, severe personal injury, or death. Refer to as-designed, certified drawings for weight, center of gravity location and details specific to unit configuration.

### Transit and Temporary Storage

If the unit is stored for an intermediate period before installation or moved to a different location, take these additional precautions:

1. Support the unit well along the length of the base rail.
2. Level the unit (no twists or uneven ground surface).
3. Provide proper drainage around the unit to prevent flooding of the equipment.
4. Provide adequate protection from vandalism, mechanical contact, etc.
5. Securely close the doors and lock the handles.
6. If there are isolation dampers, make sure they are properly installed and fully closed to prevent the entry of animals and debris through the supply and return air openings.
7. Cover the supply and return air openings on units without isolation dampers.
8. Long term storage in humid environments may cause condensate corrosion on steel surfaces. Consider adding a desiccant material to alleviate corrosion concerns.

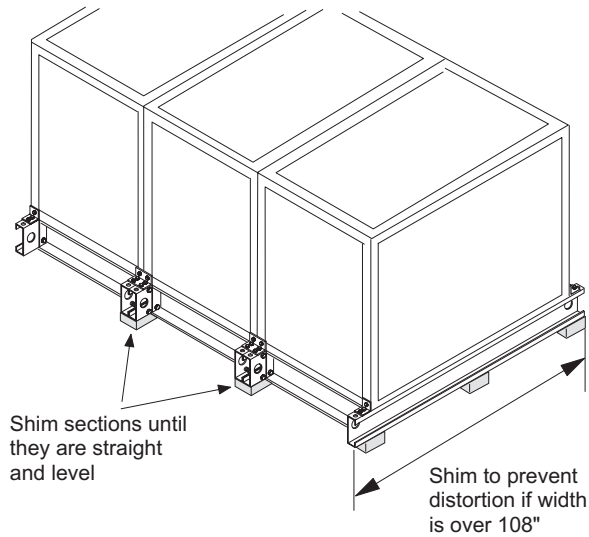
Shimming of the unit under the lifting brackets or tie-down points must be used to ensure even contact along the length of the base rail.

## Unit Leveling

Place the equipment on a flat and level surface. Where the surface irregularities could cause the equipment to distort, use a shim so the base of the unit follows a straight line. Uneven or distorted sections cause misfit or binding of the doors, panels, and improper draining of drain pans.

Units over 108" wide must rest on a flat surface for the entire width of the base rails, or must be shimmed at one or more points along the length of the rails to prevent distortion or sagging of the support rails (Figure 5).

**Figure 5: Leveling the Unit**



## Assembling Sections

Extended size units ship as separate shipping sections for field assembly. Shipping sections are provided with a connection splice joint attached to the cabinet which seals against the gasket of the frame channel on the adjoining shipping section. The splice joint provides an air seal between two sections once they are assembled together. Some unit configurations require multiple splice joints on the same face or on opposing faces of a single section. Confirm correct placement and orientation of unit sections and splice joints based on included unit drawings. Align all splice joints to seat into the mating gasket to provide an air seal. Note: Some sections are shipped with shipping braces. These need to be removed before connecting the shipping sections.

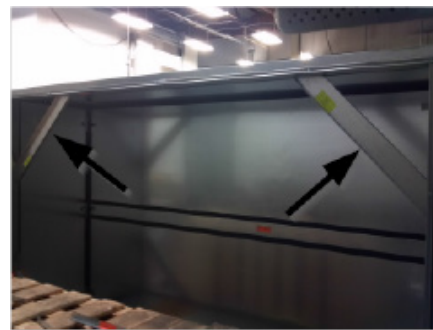
### NOTICE

Splice collars are built with foam inserts that should NOT be removed during installation (see Figure 6).

**Figure 6: Foam Inserts**



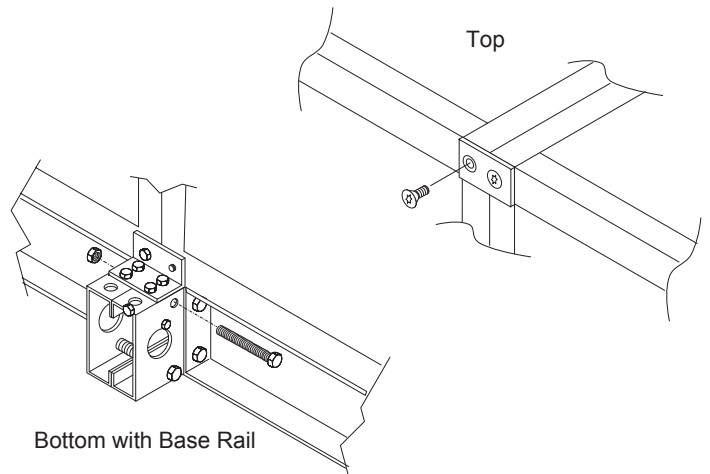
**Figure 7: Shipping Braces**



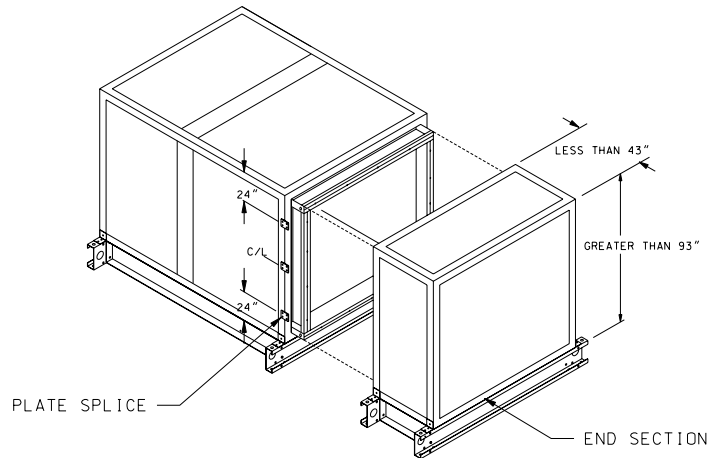
## Horizontal Airflow Section Mounting

1. Rig the section into position and line shipping sections up in the direction of airflow. Each section is clearly marked as to the order of assembly.
2. As the sections are set in place, the holding pins must be removed from the retractable/removable lifting brackets. Once the pins are removed, the retractable lifting brackets can be easily tucked into the base rail and and/or the removable lifting brackets can be removed, allowing the mating section to seat firmly against the adjoining section.
3. Pull sections together to fasten. Use a furniture clamp (or straps) and a ratchet to help pull the sections together securely at the top and bottom.
4. The unit has a factory-installed base rail. Fasten the base rails together using the 3/8"-16 x 5" bolts located in the splice kit provided with the unit.
  - a. To fasten two shipping sections together, four bolts are needed (two on each side of the unit). The bolts run from one base rail into the other and are fastened with a nut. Complete each bottom/top section before attaching additional sections.
5. Once the sections are positioned together, additional section-to-section straps must be secured.
  - a. Remove the flat head Torx 30 fastener located in each of the top channel corners (on the mating edges in the channel piece).
  - b. Mount the joining strap (shorter strap found in the splice kit, see [Figure 8](#)), over the two coned holes in the channels and refasten the flat head Torx 30 fasteners through the joining plate.
6. Locate and remove the panel screws on each side of the air handler top panel, as close to the center of each panel (of each half) as possible. Secure the mounting straps (longer strap found in the splice kit) as shown in [Figure 10](#).
6. For certain high pressure, low leakage units, use the provided section joining plates to fasten sections together. Space them as shown in [Figure 9](#). Using the provided 1/4"-14 x 1" self tapping screws, drill screw the joining plates into the frame channel on each section, keeping unit sections tight together. Follow instruction drawing included in the assembly kit.

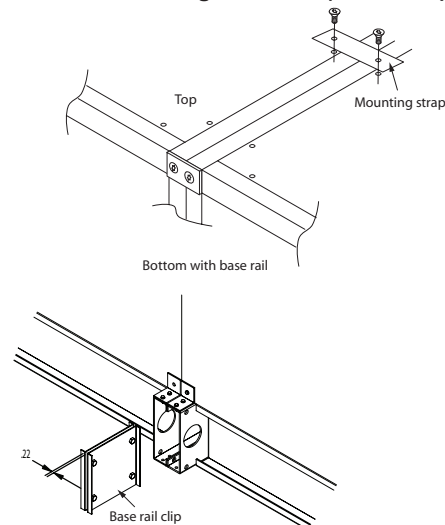
**Figure 8: Horizontal Joining Sections**



**Figure 9: Frame Channel Stiffener Plates (High Pressure, Low Leakage Units Only)**



**Figure 10: Horizontal Joining Sections (Base Rail)**

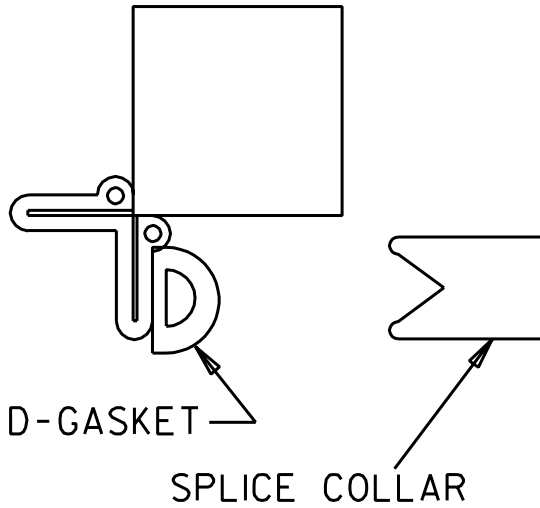


For positive pressure sections (sections located after the supply fan), a base rail join piece needs to be installed to provide a good seal in the bottom of the air handler.

1. Adjust the base rail clip bolts to fit over the adjoining base rail flanges (loose enough for the piece to slide and yet tight enough to provide a good seal). See [Figure 10](#).
2. Push the clip with a long narrow board or broom handle (something half the width of the unit) to the center of the air handler top panel, as close to the center of each panel (of each half) as possible. Secure the mounting straps (longer strap found in the splice kit) as shown in [Figure 10](#).

For high pressure, low leakage units, ensure that the D-gasket is attached to the entering air side frame channel ([Figure 11](#)). If it has dislodged during shipping, restore to original location.

**Figure 11: D-Gasket Placement Detail (High Pressure, Low Leakage Units only)**

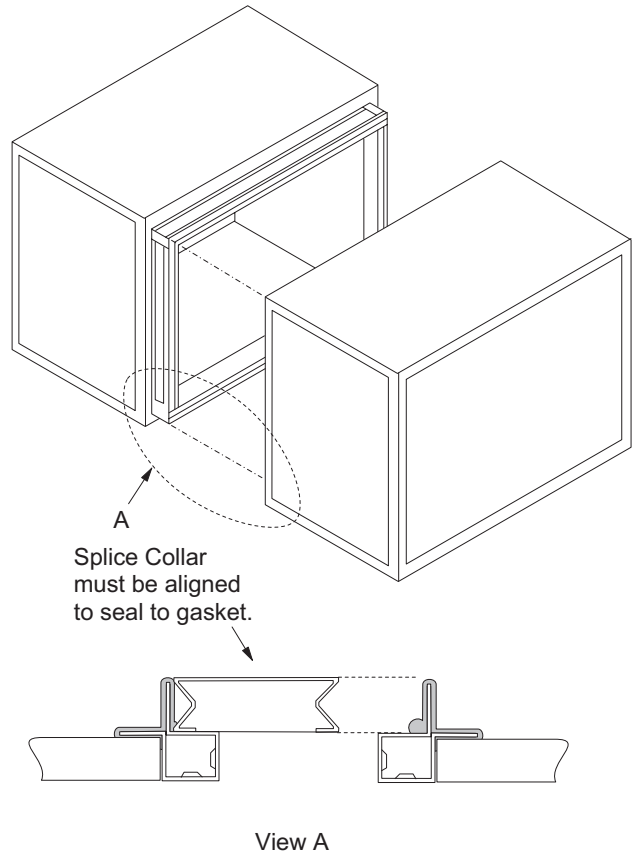


**Internal Section-to-Section Mounting**

If desired, shipping sections can be fastened together internally. To fasten internally, run field-provided #10 sheet metal screws or drill screws (4" long maximum) through the interior frame channel of one unit into the splice joint of the neighboring section.

A section-to-section splice joint provided seals against the frame channel on the entering-air side of the adjoining section. Align the splice joint to seat into the mating gasket to provide an air seal. If the splice joint was bent during shipping or rigging, restore it to its original position.

**Figure 12: Internal Fastening**

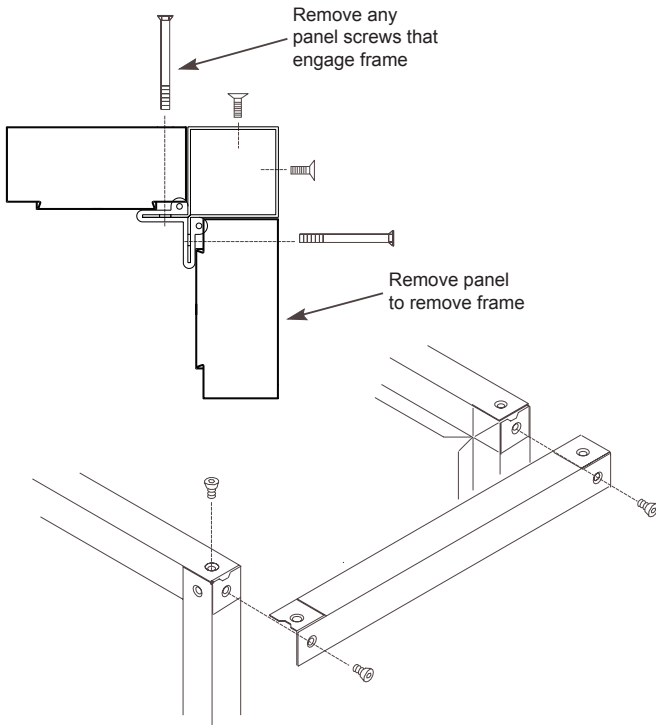


## Panels, Frame Channels, and Doors

### Panel Removal

To remove a side or top panel, remove the flat head Torx 30 fasteners along the sides of the panel. Lift off the panel after removing all fasteners.

**Figure 13: Removing Panel Screws**



### Frame Channel Removal

Top frame channels that run the length of the unit can be removed to allow access to both the side and top of the unit. To remove the frame channel, first remove the side panel(s). Once the side panel is off, remove the flat head Torx 30 fasteners in the corner of the frame channels and pull the frame channel out the side. Remove any panel screws that are within 1" of the of the frame, since they are engaged into the gasketed flange of the frame. See [Figure 13](#).

### Fan Section Doors

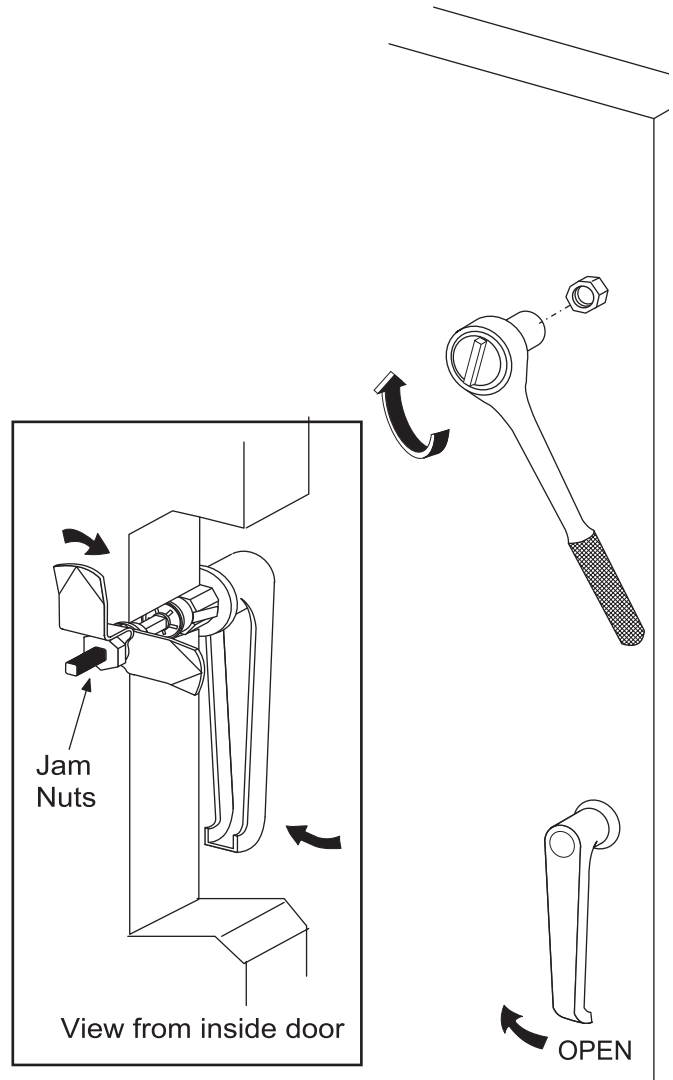
**CAUTION**

Sharp edges and coil surfaces are a potential injury hazard. Avoid contact with them.


**NOTE:** Opening fan section doors requires using a 17 mm socket wrench ([Figure 14](#)), which satisfies ANSI standards and other codes that require the "use of tools" to access compartments containing moving parts or electrical wiring.

1. Insert 17 mm socket and rotate 1/4 turn clockwise as shown in [Figure 14](#). If the handle is on the left side of the door, rotate 1/4 turn counterclockwise.
2. Rotate the door handle 1/4 turn clockwise and then 1/4 turn counterclockwise to release any internal pressure or vacuum and open the door. If the handle is on the left side of the door, rotate the door handle 1/4 turn counterclockwise and then 1/4 turn clockwise.
3. To prevent air leakage, tighten the door panels by adjusting the jam nuts.

**Figure 14: Opening Fan Section Door**



## Injected-Foam Insulated Panels

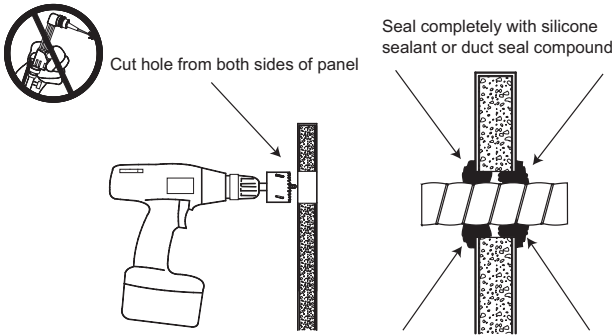
<p><b>⚠ WARNING</b></p> <p><b>Flame and smoke can cause equipment damage, severe personal injury, or death.</b></p> <p>Before operating unit, seal all piping and wiring holes on both inner and outer panels with an industrial grade silicone sealant or duct seal compound. <b>Do not use a cutting torch or expose panel to fire.</b> Panel damage can occur.</p>	
---	---

Vision air handlers are furnished with double-wall, injected foam insulated panels. Foam panels are stronger, more rigid, and lighter than panels with fiberglass insulation. The insulation R-value is improved to 13. However, foam insulation can burn when exposed to flame or other ignition sources and release toxic fumes. Use caution when cutting and sealing all field-cut openings in these panels.

### Panel Cutting Procedure

1. Determine the number and location of holes required for electrical conduit, piping, and control wiring as follows:
  - Check that adequate space is available inside the unit for conduit or pipe routing.
  - Do not locate holes in a panel that provides access to key maintenance components such as filters and fan assemblies.
  - Do not locate where the conduit or piping blocks airflow or obstructs hinged access doors.
2. Once a proper location is determined, drill a small pilot hole completely through the panel. Use a sharp hole saw or a saber saw and cut from each side of the panel.
3. Seal the double-wall panel on each side with an industrial/commercial grade silicone sealant or duct seal compound. It is extremely important to seal each panel hole or penetration securely so that it is airtight, watertight, and so that there is NO EXPOSED FOAM INSULATION.

**Figure 15: Cutting/Sealing Injected-Foam Insulated Panels**



Prop 65—Substances in fuel or from fuel combustion can cause personal injury or death, and are known to the State of California to cause cancer, birth defects or other reproductive harm.

## Field Mounting Junction Boxes and Other Components

<p><b>⚠ CAUTION</b></p> <p>Do not use self-tapping drill screws. They will not tighten nor secure properly and panel damage can occur.</p>
--

For field mounting 4" × 4" or smaller junction boxes to the standard panel exterior, use a minimum quantity of four, 3/16" diameter pop rivets.

If larger, heavier components require mounting on unit panels, use through-bolts with flat washers through both outer and inner panels. To maintain panel integrity, seal both ends with an industrial/commercial grade silicone sealant or duct seal compound.

For field mounting junction boxes with conduit, always seal conduit with electrical conduit sealant.

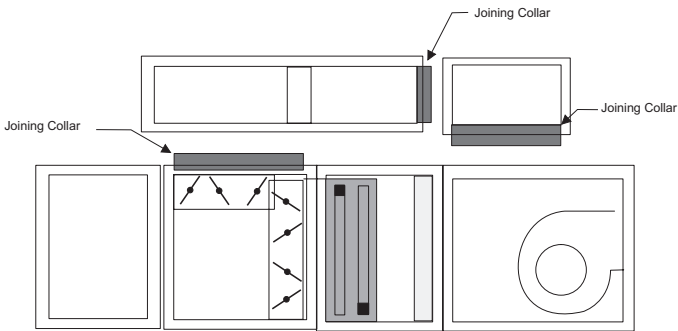
The unit frame channel is another excellent location for securing heavier components. Self-tapping screws are not acceptable; use through-bolts with flat washers and seal. Check that the location permits the full operation of all access doors and panels and does not interfere with other vital components.

## External Face and Bypass Duct Assembly

When extended size units are ordered with external face and bypass, the bypass duct ships separately and must be attached to the unit in the field. The joining of the bypass duct assembly to the unit must be done after the unit is assembled. The field assembly of the bypass duct to the unit requires the following steps (also refer to [Figure 16](#)):

1. Position the unit shipping sections together and assemble in the equipment room.
2. After the unit is assembled, lift the duct into position over the unit. Joining collars are shipped factory assembled to the unit and duct. There is a joining collar located in the top of the bypass opening and in the leaving air side of the bypass duct. These joining collars are used to provide air seals. Line up the duct with the top openings in the unit.
3. Place the duct assembly that has the joining collar on the bottom, onto the top of the unit. Once it is in place, position the other duct assembly. Use caution and fit the splice collar into the first duct assembly, and then lower the other end into the bypass opening.
4. Once the duct is positioned correctly, fasten the duct pieces together with the joining collar provided. To do this, remove the fasteners located in the corners of the duct assemblies, place the collar over the holes in the corners, and then replace the fasteners. See [Figure 8 on page 10](#).

**Figure 16: Assembly of Bypass Duct to Unit**



## Holding Frame, Filter, and Prefilter Installation

These instructions are for installing AAF HEPA filters (11-1/2" depth) into AAF HEPA Holding Frames.

Please read the entire installation instructions before beginning the installation process.

Install filters into the HEPA Holding Frames only after the frames have been securely installed into existing ductwork or housing. Frames should be bolted or pop riveted together into the permanent structure through the pre-drilled holes around the outside perimeter of the frames. Frames should be sufficiently caulked and sealed after completing installation to prevent any air bypass or leakage.

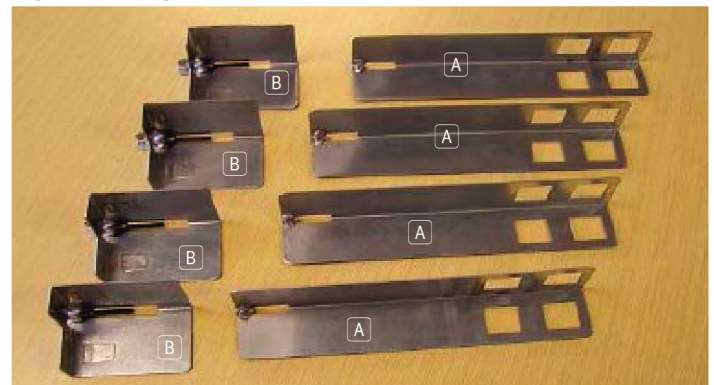
### Required tools for filter installation:

- T-handle Hexkey, size 5/32"

**Figure 17: Required Framing Components**

Component(s)	Daikin Applied PN
AAF HEPA Holding Frames	910111491 910111674
Leg Extensions, 4 per frame (A)	910111494
Latches, 4 per frame	910111493 (B) (without prefilters) 910123164 (C) (with prefilters)
Prefilter Holding Frames (when prefilters are ordered)	910123166 910123168
Prefilter Latches (when prefilters are ordered)	111048304 111048305

**Figure 18: Leg Extensions and Latches without Prefilters**



**Figure 19: Leg Extensions and Latches with Prefilters**

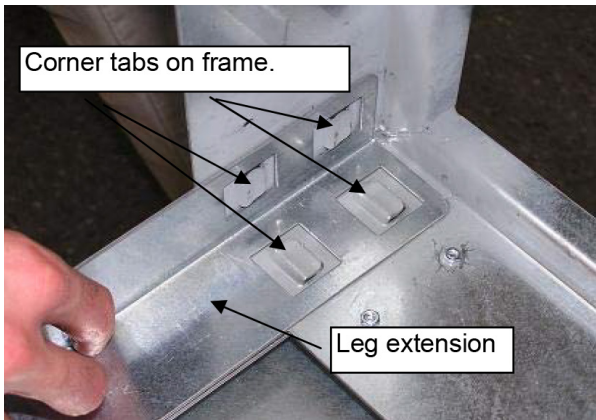


**AAF HEPA Filters without Prefilters**

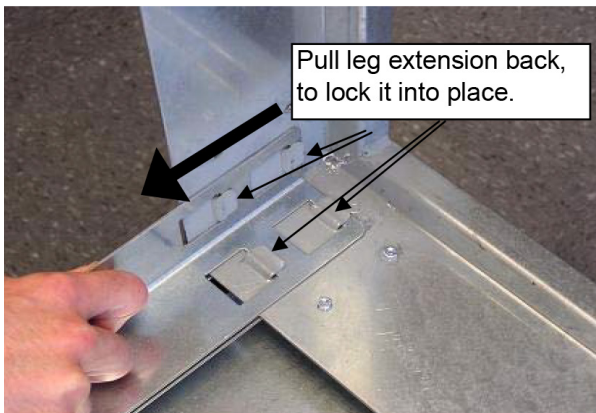
1. At the inside corner of each frame are 4 tabs, 2 per side. Place a leg extension over the 4 tabs as shown in [Figure 20](#), then pull back on the leg extension locking it into place ([Figure 21](#)).

Repeat Step 1 with each of the 4 corners. The frame with leg extensions should look like [Figure 22](#).

**Figure 20: Place Leg Extension over the Frame Tabs**



**Figure 21: Pull Back to Lock the Leg Extension into Place**



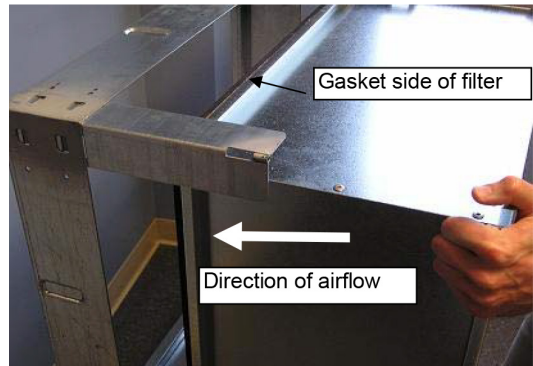
2. Insert the HEPA filter into the HEPA Holding Frame. The HEPA should be installed with the gasket side of the filter facing the frame. Insert the filter as far into the frame as possible, so that the gasket material is contacting the frame. See [Figure 23](#).

The filter should now be resting inside of the holding frame. When installing the filters into a frame bank of multiple frames, install the lower filters first so that the upper filters can rest on the lower filters ([Figure 25](#)).

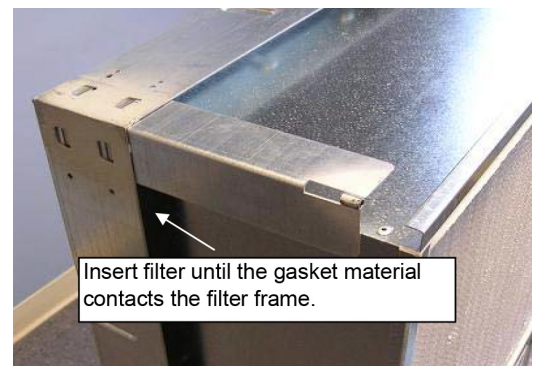
**Figure 22: Frame with Leg Extensions Installed**



**Figure 23: Insert HEPA Filter into Frame, until the Gasket Comes in Contact with the Holding Frame**



**Figure 24: Insert HEPA Filter until Gasket Material Contacts Frame**

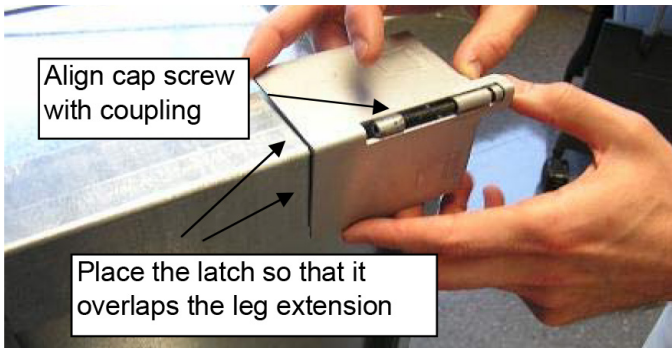


- Place a latch so that it overlaps the leg extension, as shown in [Figure 26](#). Align the latches' cap screw with the threaded coupling on the end of the leg extension and tighten using the hexkey. Tighten the cap screw until there is an approximately 1/4" gap between the latch and the leg extension coupling as shown in [Figure 27](#). Repeat this step with all 4 corners.

**Figure 25: Filter Placed Inside of Frame**



**Figure 26: Latch Overlapping Leg Extension**



**Figure 27: Tighten Cap Screw to 1/4" of the Coupling**



- Once all four corner latches have been tightened within 1/4" of the leg extension coupling, complete the installation by tightening each corner until the latch and leg extension coupling meet. This is illustrated in [Figure 28](#).

Once all four corners have been tightened the filter should now be properly seated and sealed.

Repeat the process with all remaining filters working from the bottom to the top.

**Figure 28: Tighten until Latch and Coupling Meet**



**Figure 29: Properly Installed Filter Inside of the Frame**



## AAF HEPA Filters with Prefilters

Follow steps 1-2 as directed on [page 15](#), then continue to the step below.

- The prefilter holding frame should be placed directly in front of the HEPA filter as shown in [Figure 30](#).

**Figure 30: Positioning of the Prefilter Frame**

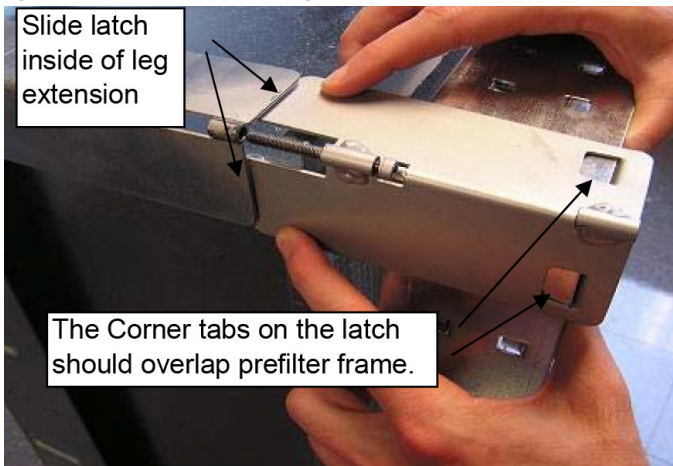


- Place a latch so that the 2 tabs of the latch overlap the prefilter frame on each side of the corner. Slide the latch inside of the leg extension and align the latches' cap screw with the threaded coupling on the end of the leg extension and tighten using the hexkey. See [Figure 31](#).

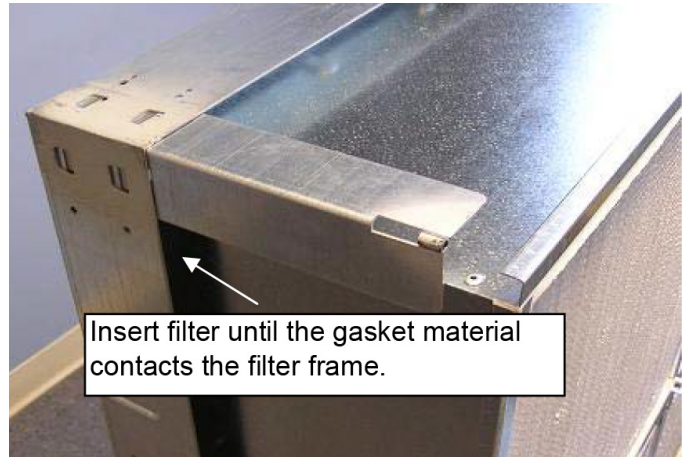
Tighten the cap screw until there is an approximately 1/4" gap between the latch and the leg extension coupling as shown in [Figure 32](#). Repeat this step with all 4 corners.

- Once all four corner latches have been tightened within 1/4" of the leg extension coupling, tighten each corner until the latch and leg extension coupling meet. This is shown in [Figure 33](#).

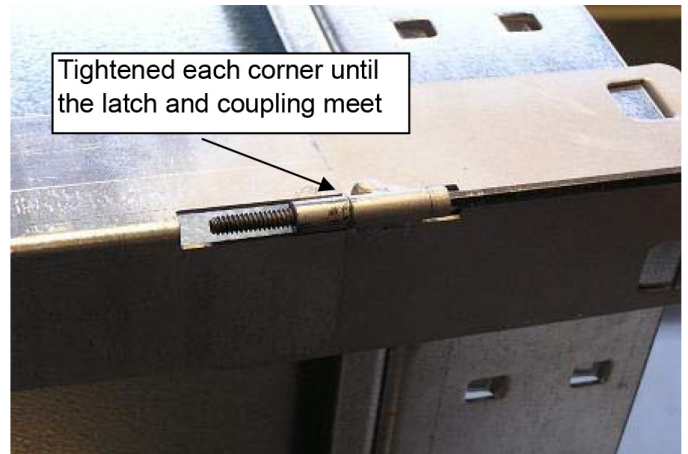
**Figure 31: Latch Positioning for Prefilter Frame**



**Figure 32: Tighten Cap Screw to 1/4" of the Coupling**



**Figure 33: Tighten until Latch and Coupling Meet**



Once all four corners have been tightened the HEPA filter should now be properly seated and sealed.

Repeat the process with all remaining filters working from the bottom to the top.

**Figure 34: Properly Installed HEPA Filter**



8. To complete the installation, add the appropriate prefilter latches to the prefilter holding frame. Once latches are installed, place the prefilter in the frame, secure with the latches and the installation is complete.
9. Repeat with all remaining prefilters and frames.

**Figure 35: Installation of Prefilter into Frame**



**Figure 36: Completed Assembly**



## Mounting Actuators

### CAUTION

Maximum damper rotation is 70°. Maximum shaft torque is 205 inches/pound. Greater rotation or torque can cause equipment damage.

The installing contractor is responsible for the mounting of all field-installed actuators. No provisions are made for the location of these actuators due to the number of options and arrangements available and the variety of specific applications. Typically, actuators are mounted inside the cabinet. Provide proper support for the actuator to avoid excessive stress in the cabinet, linkage, or damper shafts.

Fresh air and return air dampers can be linked together for each half and driven from the same actuator if the dampers are the same size. If the dampers are different sizes, they must be driven by separate actuators and controlled appropriately. Exhaust dampers are always driven by a separate actuators.

A typical rotary electric actuator can handle up to 40 sq. ft. of damper. For pneumatic actuators, allow 5 in-lb per square foot of damper area.

## Face and/or Bypass Damper Torque Requirements

The dampers are not linked and require multiple actuators - four for the face dampers and two for the bypass dampers. A damper shaft extension is provided. Normally, the shaft extension is located on the drive side of the unit, but it can be moved to the other side.

Face and bypass dampers have a torque requirement of 10 in-lbs per square foot of damper face area.

## Isolation Dampers for Multiple Fans

Optional isolation dampers can be provided on multiple fans to prevent backflow through a fan that is turned off for service. These isolation dampers are not intended to be used to control flow through the fan. The isolation damper for a fan that is going to be started must be positioned in the full open position before the fan is started. Do not start a fan with the damper located at the inlet with the damper fully or partially closed. This can cause airflow, vibration, and sound problems that can lead to failure.

Isolation dampers can be provided with actuators that are mounted in the airstream. Actuator sizing for the isolation dampers should be based on 9 in-lb per square foot of damper.

## Piping and Coils

When designing and installing piping:

- Follow applicable piping design, sizing, and installation information in ASHRAE handbooks.
- Vision units paired with a condenser section as part of a split system should review the condenser installation manual for relevant pipe design guidelines.
- Observe all local codes and industry standards.
- Do not apply undue stress at the connection to coil headers; always use a backup pipe wrench.
- Support pipework independently of the coils.
- Maximum design pressure is labeled on the exterior of the unit.

## Field-Installed Coils

1. Prior to installing the filler panel and coil panel, apply even beads of caulk around the entire drain pan.
2. Smooth out any excess and allow it to fully cure.
3. Inspect the seal for any gaps or voids. Apply additional caulk as needed to ensure a complete seal.
4. Confirm that the drain pan is fully sealed before proceeding with panel installation.

## Water Cooling Coils

- Water supply, water return, drain, and vent connections extend through the end panel of the coil section. All connections are labeled on the end panel.
- Water supply and water return connections are typically male NPT iron pipe.
- When installing couplings, do not apply undue stress to the connection extending through unit panel. Use a backup pipe wrench to avoid breaking the weld between coil connection and header.
- Follow recommendations of the control manufacturer regarding types, sizing, and installation of controls.

## Direct Expansion Coils

### Non-A2L Refrigerant Type

- When a field supplied thermostatic expansion valve is used, it is located outside the unit and connected directly to the distributor. Do not apply heat to the body of the expansion valve.
- The thermostatic expansion valve must be of the external equalizer tube type. Connect the 1/4" diameter external equalizer tube provided on the coil to connection on expansion valve.
- See EPA regulation for serviceable coil installation rules and guidelines. Equipment shipped after 01/01/2025 will be supplied with a label indicating that it is intended for servicing existing equipment only. This will be applicable to systems with a total capacity less than 65,000 BTUs.

### R32 and R454B Refrigerant Type

- Expansion valves are not provided by Daikin Applied. See the condenser unit manufacturer's unit literature for expansion valve type and size. Expansion valve to be located outside the unit and connected directly to the distributor. Do not apply heat to the body of the expansion valve.
- The coil distributor and suction connection extend through the end panel of the coil section.
- Check nozzle in distributor for proper tonnage. Use care when piping the system to see that all joints are tight and all lines are dry and free of foreign material. For typical refrigerant piping, see the condensing unit literature.
- See condensing unit literature for refrigerant charging instructions.
- Direct expansion coils shall only be connected and operated with condensing units rated for the same refrigerant.

## Modulating Hot Gas Reheat (MHGRH)

- MHGRH is offered as a combination coil, mounted downstream of a cooling DX coil in a single component section.
- MHGRH coil will be factory installed and will have input (discharge), output (liquid) connection points, and field piping connections.

### Minimum Room Area Calculation (A2L Refrigerants)

#### WARNING

Never allow this unit to service room(s) in which the total room area does not meet the minimum room area requirement. This may lead to flammable or toxic conditions, causing equipment damage, serious personal injury, or death.

- Units installed with an A2L refrigerant must be evaluated for each circuit's total charge. Total refrigerant charge is calculated by adding the DX coil, field piping, and condenser charge together for a particular circuit.
- Using the circuit with the greater total charge (if applicable), the minimum allowable room area must be calculated and recorded on the unit safety label. See [Minimum Room Area on page 48](#) for guidance on the minimum allowable room area calculation.

**NOTE:** Use permanent marker that conforms to ASTM D-4236.

## Steam Coils

### Piping (see [Figure 38 on page 22](#))

- All steam coils in units are pitched toward return connection.
- Steam supply and steam return connections typically are male NPT iron pipe and are labeled on the end panel of coil section. Connections extend through the coil section end panel.

- When installing couplings, do not apply undue stress to the connection extending through unit panel. Use a backup pipe wrench to avoid breaking the weld between coil connection and header.
- Support piping independently of coils and provide adequate piping flexibility. Stresses resulting from expansion of closely coupled piping can cause serious damage.
- Do not reduce pipe size at the coil return connection. Carry return connection size through the dirt pocket, making the reduction at the branch leading to the trap.

### Coils

- Install vacuum breakers on all application to prevent retaining condensate in the coil. Generally, the vacuum breaker is connected between the coil inlet and the return main. The vacuum breaker should be open to the atmosphere, and the trap design should allow venting of large quantities of air.
- Do not drip supply mains through the coil.
- Do not attempt to lift condensate when using modulating or ON/OFF control.

### Traps

- Size traps in accordance with the manufacturers' recommendations. Make sure that the required pressure differential is always available. Do not undersize.
- Use float and thermostatic or bucket traps for low pressure steam. On high pressure steam, use bucket traps. Use thermostatic traps only for air venting.
- Use bucket traps for ON/OFF control only.
- Locate traps at least 12 inches below the coil return connection.
- Multiple coil installation:
- Individually trap each coil or group of coils that is controlled individually trapped.
- Coils in series—use separate traps for each coil, or bank of coils.
- Coils in parallel—a single trap can be used, but an individual trap for each coil is preferred.
- Do not attempt to lift condensate when using modulating or ON/OFF control.
- With coils arranged for series airflow, use a separate control on each bank or coil in the direction of airflow.

### Valves

- Do not use modulating steam valves on high pressure systems.
- Properly size modulating valves. Do not undersize.
- Freezing conditions (entering air temperatures below 35°F).
  - Daikin Applied strongly recommends 5JA, 8JA, 5RA and 8RA coils.
  - Supply 5 psi steam to coils at all times.
- Do not use modulating valves. Provide control by face and bypass dampers:
  - Consider using two or three coils in series with two

position steam control valves on the coil or coils that handle 35°F or colder air. Use a modulating valve on the downstream coil to provide the desired degree of control.

- Thoroughly mix fresh air and return air before it enters the coil. Also, to obtain true air mixture temperatures, properly locate temperature control elements.
- For additional protection against freeze-up, install the trap sufficiently below the coil to provide an adequate hydrostatic head to remove condensate during an interruption in the steam pressure. Estimate three feet for each 1 psi of trap differential required.
- On startup, admit steam to coil ten minutes before admitting outdoor air.
- Close fresh air dampers if steam supply pressure falls below the minimum specified.

### Pipe Chases

Follow these guidelines when routing field supplied internal piping through the bottom of a unit.

- Determine what style base and options were selected:
  - Was an uninsulated sheet metal pipe chase cover selected?
- Determine the number and location of holes required for piping as follows:
  - Check that adequate space is available inside the unit for pipe routing.
  - Hole(s) must be located fully within panels or sheet metal opening covers. Do not run pipes through 4" wide intermediate panels or on the very edge of the panel.
  - Do not place holes in a location that impedes access to key maintenance components such as filters and fan assemblies.
  - Do not place holes in a location where the pipe will block airflow or obstruct hinged access doors.
- Once a proper location is determined:
  - If no pipe chase cover is present:
    - a. Drill a small pilot hole completely through the bottom cabinet panel, then using a sharp hole saw or saber saw, cut the desired final hole size and smooth the edges of the cut.
  - If a pipe chase cover is present:
    - a. Remove the pipe chase cover.
    - b. Drill a small pilot hole completely through the pipe chase cover, then using a sharp hole saw or saber saw, cut the desired final hole size and smooth the edges of the cut.
  - After installation of the piping, seal the hole(s) in the bottom cabinet panel or pipe chase cover.
    - a. Seal the holes to divert any moisture away from the opening and prevent moisture leakage through the holes.
    - b. Recommended sealing options include: flashing material, caulk, spray foam, cork tape, industrial

or commercial grade silicone sealant, duct seal compound, or other similar sealing material.

- c. Pipe chase covers are not guaranteed to be airtight or watertight, but the pipe chase cover may be sealed in a similar manner to the other penetrations of the pipe chase cover if desired.

**NOTE:** The installer is responsible for ensuring the penetrations are fully sealed.

**NOTE:** Do not support piping off of the unit, or coil connections.

**NOTE:** It is extremely important to seal each hole or penetration securely so that they are airtight and watertight.

## Water Heating Coils

**CAUTION**

Improper installation, use, or maintenance of water heating coils can cause equipment damage. Read and follow instructions carefully.

- Water supply and water return connections extend through the end panel of the coil section. All connections are labeled on the end panel.
- Water supply and water return connections are male NPT iron pipe.
- When installing couplings, do not apply undue stress to the connection extending through unit panel. Use a backup pipe wrench to avoid breaking the weld between the coil connection and header.
- Follow recommendations of the control manufacturer regarding types, sizes, and installation of controls.
- Do not use hot water coils with entering air below 40°F.
- If fresh air and return air are to be heated by a hot water coil, carefully design the system to provide thorough mixing before air enters the coil.
- To prepare coils for winter operation, see [See Removing and Replacing Components on page 64](#).

## Drain Pan Traps

Run drain lines and traps full size from the drain pan connection. Install drain pan trap to allow condensate to drain freely. On both blow-through and draw-through units, the trap depth and the distance between the trap outlet and the drain pan outlet must be twice the static pressure in the drain pan section under normal operation so the trap remains sealed. See [Figure 37](#).

**Figure 37: Allow Adequate Distance Between Trap Outlet and Drain Pan Outlet**

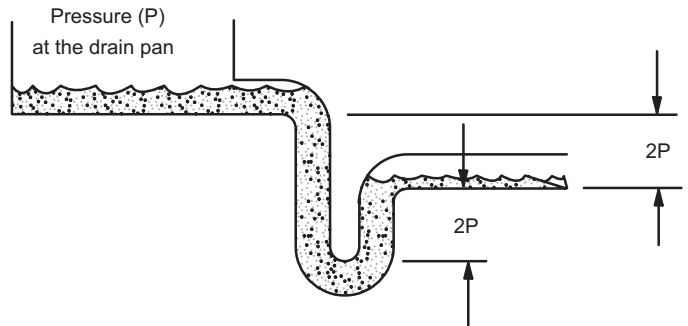
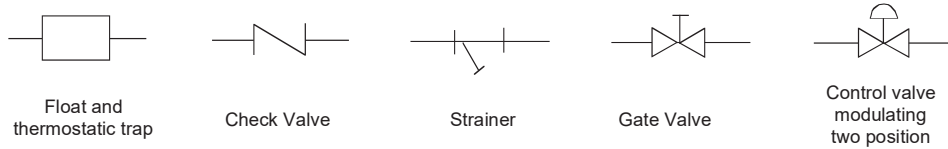
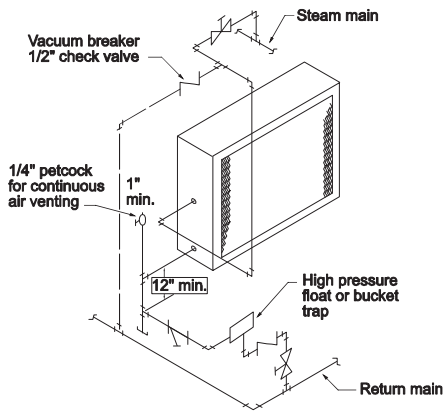


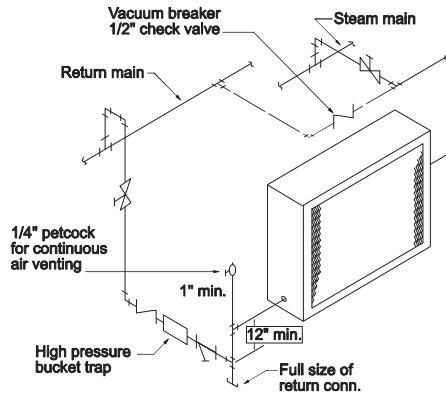
Figure 38: Piping Arrangements



**High Pressure (over 25 psi)**

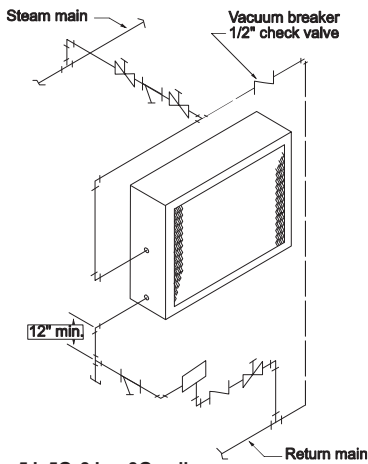


**5GA or 8GA coils.** Note that the addition of a vacuum breaker to permit the coil to drain during shutdown.

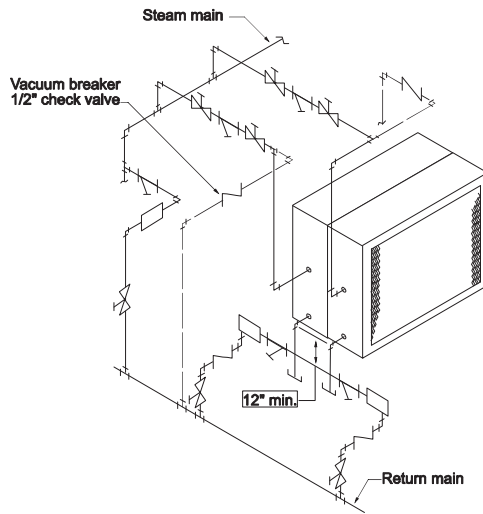


**5TA, 8TA, or 5HA coils.** Condensate is lifted to overhead return main

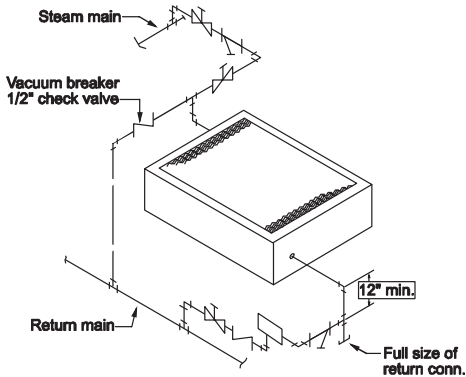
**Low Pressure (to 25 psi)**



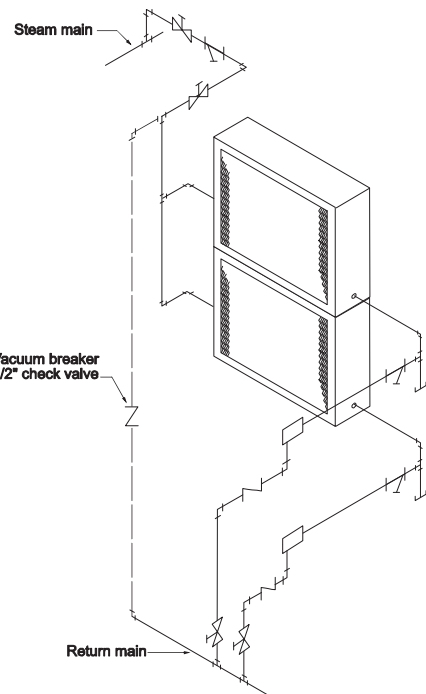
**5J, 5G, 8J or 8G coils.**



**5JA or 8JA coil.** Installed in series. Note that each coil must have a separate control valve and trap.



**5RA, 8RA, or 5SA coils.**



**5RA, 8RA, or 5SA coils.** Banked two high, individual trapping of each coil as shown is preferred.

# Integral Face and Bypass Coils - Torque Requirements

## Non-Spring Return Actuator - Vertical Tubes

**Table 1: Non-Spring Return Actuator Selections Information**

Non-Spring Return Actuator Selections			
	Torque Rating	Max Face Area	Quantity Needed
<b>LM SERIES</b>	45 in-lb	11 sq. ft	1
<b>NM SERIES</b>	90 in-lb	22 sq. ft	1
<b>AM SERIES</b>	180 in-lb	45 sq. ft	1
<b>GM SERIES</b>	360 in-lb	90 sq. ft	1

**Table 2: LM Series Torque Requirements**

LM Series - Vertical Tubes - Face Area (sq. ft.)									
		Nominal Tube Length							
		2'- 0"	2'- 6"	3'- 0"	3'- 6"	4'- 0"	4'- 6"	5'- 0"	5'- 6"
Tube Face	8	3.7	4.7	5.6	6.5	7.4	8.4	9.3	10.2
	12	5.6	7.0	8.3	9.7	-	-	-	-
	16	7.4	9.2	-	-	-	-	-	-
	20	9.2	-	-	-	-	-	-	-

**Table 3: NM Series Torque Requirements**

NM Series - Vertical Tubes - Face Area (sq. ft.)														
		Nominal Tube Length												
		2'- 0"	2'- 6"	3'- 0"	3'- 6"	4'- 0"	4'- 6"	5'- 0"	5'- 6"	6'- 0"	6'- 6"	7'- 0"	7'- 6"	8'- 0"
Tube Face	8	-	-	-	-	-	-	-	-	11.2	12.1	13.0	14.0	14.9
	12	-	-	-	-	11.1	12.5	13.9	15.3	16.7	18.1	19.5	20.9	
	16	-	-	11.1	12.9	14.8	16.6	18.5	20.3	-	-	-	-	-
	20	-	11.5	13.8	16.1	18.4	20.7	-	-	-	-	-	-	-
	24	11.1	13.8	16.6	19.4	-	-	-	-	-	-	-	-	-
	28	13.3	16.6	19.9	-	-	-	-	-	-	-	-	-	-
	32	14.7	18.4	-	-	-	-	-	-	-	-	-	-	-
	36	16.6	20.7	-	-	-	-	-	-	-	-	-	-	-
	40	18.4	-	-	-	-	-	-	-	-	-	-	-	-
44	20.2	-	-	-	-	-	-	-	-	-	-	-	-	

**Table 4: AM Series Torque Requirements**

AM Series - Vertical Tubes - Face Area (sq. ft.)														
		Nominal Tube Length												
		2'- 0"	2'- 6"	3'- 0"	3'- 6"	4'- 0"	4'- 6"	5'- 0"	5'- 6"	6'- 0"	6'- 6"	7'- 0"	7'- 6"	8'- 0"
Tube Face	8	-	-	-	-	-	-	-	-	-	-	-	-	-
	12	-	-	-	-	-	-	-	-	-	-	-	-	22.2
	16	-	-	-	-	-	-	-	-	22.1	24.0	25.8	27.7	29.5
	20	-	-	-	-	-	-	23.1	25.4	27.7	30.0	32.3	34.6	36.9
	24	-	-	-	-	22.1	24.9	27.7	30.4	33.2	35.9	38.7	41.5	44.2
	28	-	-	-	23.2	26.6	29.9	33.2	36.5	39.8	43.2	-	-	-
	32	-	-	22.1	25.8	29.4	33.1	36.8	40.5	44.2	-	-	-	-
	36	-	-	24.8	29.0	33.1	37.3	41.4	-	-	-	-	-	-
	40	-	23.0	27.6	32.2	36.8	41.4	-	-	-	-	-	-	-
	44	-	25.3	30.4	35.4	40.5	-	-	-	-	-	-	-	-
48	22.1	27.6	33.1	38.6	44.1	-	-	-	-	-	-	-	-	

**Table 5: GM Series Torque Requirements**

		GM Series - Vertical Tubes - Face Area (sq. ft.)												
		Nominal Tube Length												
		2'- 0"	2'- 6"	3'- 0"	3'- 6"	4'- 0"	4'- 6"	5'- 0"	5'- 6"	6'- 0"	6'- 6"	7'- 0"	7'- 6"	8'- 0"
Tube Face	8	-	-	-	-	-	-	-	-	-	-	-	-	
	12	-	-	-	-	-	-	-	-	-	-	-	-	
	16	-	-	-	-	-	-	-	-	-	-	-	-	
	20	-	-	-	-	-	-	-	-	-	-	-	-	
	24	-	-	-	-	-	-	-	-	-	-	-	-	
	28	-	-	-	-	-	-	-	-	-	-	46.5	49.8	53.1
	32	-	-	-	-	-	-	-	-	-	47.8	51.5	55.2	58.9
	36	-	-	-	-	-	-	-	45.5	49.7	53.8	58.0	62.1	66.2
	40	-	-	-	-	-	-	46.0	50.5	55.1	59.7	64.3	68.9	73.5
	44	-	-	-	-	-	45.5	50.6	55.7	60.7	65.8	70.8	75.9	81.0
48	-	-	-	-	-	49.6	55.2	60.7	66.2	71.7	77.2	82.7	88.2	

**Spring Return Actuator - Vertical Tubes**

**Table 6: Spring Return Actuator Selections Information**

Spring Return Actuator Selections - Vertical			
	Torque Rating	Max Face Area	Quantity Needed
NF SERIES	60 in-lb	15 sq. ft.	1
AF SERIES	133 in-lb	33 sq. ft.	1
AF SERIES	266 in-lb	66 sq. ft.	2
FACE AREA TOO LARGE - MUST USE NON-SPRING RETURN ACTUATOR			

**Table 7: NF Series Torque Requirements**

		NF Series - Vertical Tubes - Face Area (sq. ft.)												
		Nominal Tube Length												
		2'- 0"	2'- 6"	3'- 0"	3'- 6"	4'- 0"	4'- 6"	5'- 0"	5'- 6"	6'- 0"	6'- 6"	7'- 0"	7'- 6"	8'- 0"
Tube Face	8	3.7	4.7	5.6	6.5	7.4	8.4	9.3	10.2	11.2	12.1	13.0	14.0	14.9
	12	5.6	7.0	8.3	9.7	11.1	12.5	13.9	-	-	-	-	-	-
	16	7.4	9.2	11.1	12.9	14.8	-	-	-	-	-	-	-	-
	20	9.2	11.5	13.8	-	-	-	-	-	-	-	-	-	-
	24	11.1	13.8	-	-	-	-	-	-	-	-	-	-	-
	28	13.3	-	-	-	-	-	-	-	-	-	-	-	-
	32	14.7	-	-	-	-	-	-	-	-	-	-	-	-
	36	-	-	-	-	-	-	-	-	-	-	-	-	-
	40	-	-	-	-	-	-	-	-	-	-	-	-	-
	44	-	-	-	-	-	-	-	-	-	-	-	-	-
48	-	-	-	-	-	-	-	-	-	-	-	-	-	

**Table 8: AF Series (133 in-lb) Torque Requirements**

		AF Series (133 in-lb) - Vertical Tubes - Face Area (sq. ft.)												
		Nominal Tube Length												
		2'- 0"	2'- 6"	3'- 0"	3'- 6"	4'- 0"	4'- 6"	5'- 0"	5'- 6"	6'- 0"	6'- 6"	7'- 0"	7'- 6"	8'- 0"
Tube Face	8	-	-	-	-	-	-	-	-	-	-	-	-	-
	12	-	-	-	-	-	-	-	15.3	16.7	18.1	19.5	20.9	22.2
	16	-	-	-	-	-	16.6	18.5	20.3	22.1	24.0	25.8	27.7	29.5
	20	-	-	-	16.1	18.4	20.7	23.1	25.4	27.7	30.0	32.3	-	-
	24	-	-	16.6	19.4	22.1	24.9	27.7	30.4	-	-	-	-	-
	28	-	16.6	19.9	23.2	26.6	29.9	-	-	-	-	-	-	-
	32	-	18.4	22.1	25.8	29.4	-	-	-	-	-	-	-	-
	36	16.6	20.7	24.8	29.0	-	-	-	-	-	-	-	-	-
	40	18.4	23.0	27.6	32.2	-	-	-	-	-	-	-	-	-
	44	20.2	25.3	30.4	-	-	-	-	-	-	-	-	-	-
48	22.1	27.6	-	-	-	-	-	-	-	-	-	-	-	

**Table 9: AF Series (266 in-lb) Torque Requirements**

		AF Series (266 in-lb) - Vertical Tubes - Face Area (sq. ft.)												
		Nominal Tube Length												
		2'- 0"	2'- 6"	3'- 0"	3'- 6"	4'- 0"	4'- 6"	5'- 0"	5'- 6"	6'- 0"	6'- 6"	7'- 0"	7'- 6"	8'- 0"
Tube Face	8	-	-	-	-	-	-	-	-	-	-	-	-	-
	12	-	-	-	-	-	-	-	-	-	-	-	-	-
	16	-	-	-	-	-	-	-	-	-	-	-	-	-
	20	-	-	-	-	-	-	-	-	-	-	-	34.6	36.9
	24	-	-	-	-	-	-	-	-	33.2	35.9	38.7	41.5	44.2
	28	-	-	-	-	-	-	33.2	36.5	39.8	43.2	46.5	49.8	53.1
	32	-	-	-	-	-	33.1	36.8	40.5	44.2	47.8	51.5	55.2	58.9
	36	-	-	-	-	33.1	37.3	41.4	45.5	49.7	53.8	58.0	62.1	<b>66.2</b>
	40	-	-	-	-	36.8	41.4	46.0	50.5	55.1	59.7	64.3	<b>68.9</b>	<b>73.5</b>
	44	-	-	-	35.4	40.5	45.5	50.6	55.7	60.7	65.8	<b>70.8</b>	<b>75.9</b>	<b>81.0</b>
48	-	-	33.1	38.6	44.1	49.6	55.2	60.7	<b>66.2</b>	<b>71.7</b>	<b>77.2</b>	<b>82.7</b>	<b>88.2</b>	

**NOTE:** Figures in bold with grey background indicate face area being too large. A non-spring return actuator must be used.

**Non-Spring Return Actuator - Horizontal Tube**

**Table 10: Non-Spring Return Actuator Selections Information (Horizontal)**

Non-Spring Return Actuator Selections (Horizontal)			
	Torque Rating	Max Face Area	Quantity Needed
<b>LM SERIES</b>	45 in-lb	11 sq. ft	1
<b>NM SERIES</b>	90 in-lb	22 sq. ft	1
<b>AM SERIES</b>	180 in-lb	45 sq. ft	1

**Table 11: LM Series Torque Requirements**

		LM Series - Horizontal Tube - Face Area (sq. ft.)									
		Nominal Tube Length									
		1'- 0"	1'- 6"	2'- 0"	2'- 6"	3'- 0"	3'- 6"	4'- 0"	4'- 6"	5'- 0"	
Tube Face	9	1.66	2.48	3.31	4.14	4.97	5.80	6.63	7.45	8.28	
	12	2.30	3.45	4.59	5.74	6.89	8.04	9.19	10.34	-	
	15	2.94	4.41	5.88	7.34	8.81	10.28	-	-	-	
	18	3.58	5.37	7.16	8.95	10.73	-	-	-	-	
	21	4.22	6.33	8.44	10.55	-	-	-	-	-	
	24	4.86	7.29	9.72	-	-	-	-	-	-	

**Table 12: NM and AM Series Torque Requirements**

		NM and AM Series - Horizontal Tube - Face Area (sq. ft.)									
		Nominal Tube Length									
		1'- 0"	1'- 6"	2'- 0"	2'- 6"	3'- 0"	3'- 6"	4'- 0"	4'- 6"	5'- 0"	
Tube Face	9	-	-	-	-	-	-	-	-	-	
	12	-	-	-	-	-	-	-	-	11.48	
	15	-	-	-	-	-	-	11.75	13.22	14.69	
	18	-	-	-	-	-	12.52	14.31	16.10	17.89	
	21	-	-	-	-	12.66	14.77	16.88	18.98	21.09	
	24	-	-	-	12.15	14.58	17.01	19.44	21.87	<b>24.30</b>	

**NOTE:** Figure in bold with grey background indicates AM series torque value.

### Spring Return Actuator - Horizontal Tube

**Table 13: Spring Return Actuator Selections Information (Horizontal)**

Spring Return Actuator Selections (Horizontal)			
	Torque Rating	Max Face Area	Quantity Needed
NF SERIES	60 in-lb	15 sq. ft.	1
AF SERIES	133 in-lb	33 sq. ft.	1

**Table 14: NF Series Torque Requirements**

NF Series - Horizontal Tube - Face Area (sq. ft.)										
		Nominal Tube Length								
		1'- 0"	1'- 6"	2'- 0"	2'- 6"	3'- 0"	3'- 6"	4'- 0"	4'- 6"	5'- 0"
Tube Face	9	1.66	2.48	3.31	4.14	4.97	5.80	6.63	7.45	8.28
	12	2.30	3.45	4.59	5.74	6.89	8.04	9.19	10.34	11.48
	15	2.94	4.41	5.88	7.34	8.81	10.28	11.75	13.22	14.69
	18	3.58	5.37	7.16	8.95	10.73	12.52	14.31	-	-
	21	4.22	6.33	8.44	10.55	12.66	14.77	-	-	-
	24	4.86	7.29	9.72	12.15	14.58	-	-	-	-

**Table 15: AF Series Torque Requirements**

AF Series - Horizontal Tube - Face Area (sq. ft.)										
		Nominal Tube Length								
		1'- 0"	1'- 6"	2'- 0"	2'- 6"	3'- 0"	3'- 6"	4'- 0"	4'- 6"	5'- 0"
Tube Face	9	-	-	-	-	-	-	-	-	-
	12	-	-	-	-	-	-	-	-	-
	15	-	-	-	-	-	-	-	-	-
	18	-	-	-	-	-	-	-	16.10	17.89
	21	-	-	-	-	-	-	16.88	18.98	21.09
	24	-	-	-	-	-	17.01	19.44	21.87	24.30

## Internal Fan Isolation Assembly Adjustment

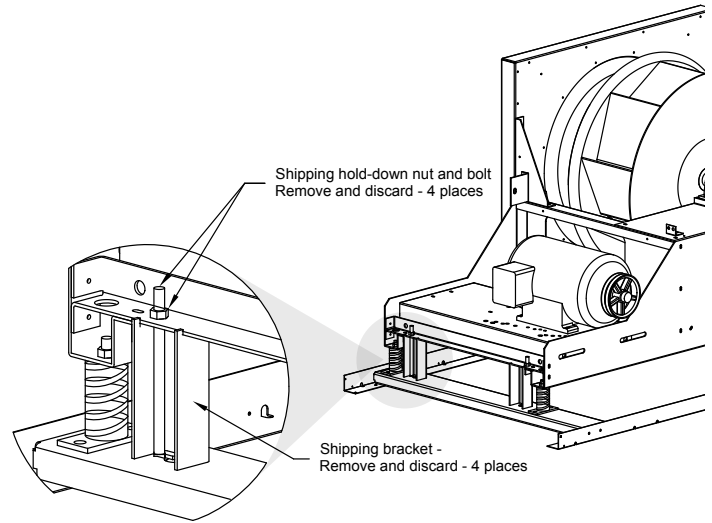
### NOTICE

Fan assemblies with internal isolation are locked down for shipment. The assembly is secured at four location. On units with internally isolated fan and motor assemblies, the assemblies are secured for shipment. Make sure all shipping brackets are removed before installation and while there is access to both sides of the unit.

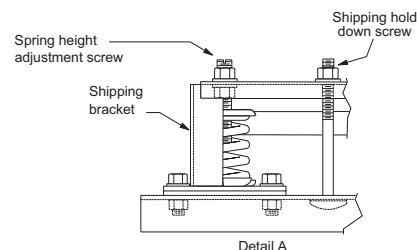
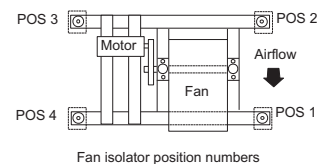
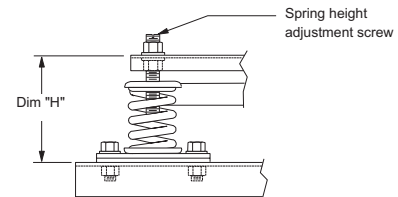
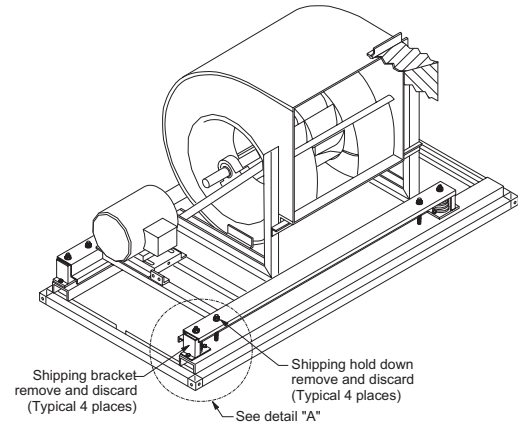
### Before Operating the Unit:

Remove the shipping brackets and tie-down bolts (see [Figure 40](#) and [Figure 39](#)) and discard. The shipping brackets located on the opposite drive side of the unit are difficult to access from the drive side of the unit. Either remove them before the unit is assembled, or remove the panel on the opposite drive side to gain access.

**Figure 39: Class II Belt-Drive Fan Shipping Bracket**



**Figure 40: Removing Shipping Brackets**



### Spring Mount Assembly (Class 1 & 2)

The spring isolators under the four corners of the fan and motor assembly are factory adjusted while the fan was not running. See Table 16 through Table 19 below.

**Table 16: Spring Mount Adjustments (Refer to Figure 41)**

Spring mount adjustment at rest		
Isolator position	Top or bottom horz. H (in.)	Upblast H (in.)
1	6.00	6.50
2	6.50	6.50
3	6.50	6.50
4	6.00	6.50

**Table 17: Class II Belt-Drive Plenum Fan Spring Height**

Fan Size	Operating Height (in.)
18-36	4.0
40-60	6.75

**Table 18: Class III Plenum Fan Spring Height**

Cabinet Width	Operating Height (in.)
Width < 108"	4.0
Width >= 108"	6.75

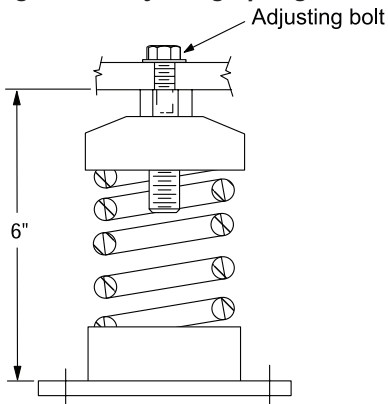
**Table 19: Class II Direct-Drive Plenum Fan Spring Height**

Fan Size	Operating Height (in.)
18-36	4.0
40-44	6.75

With the unit operating at normal cfm and static pressure, all the isolators should be at the same height opening. If adjustments are required, loosen the 1/2" cap screw on top of the isolator and turn the adjusting bolt to lower or raise the fan and motor base. Retighten the cap screw when adjustments are completed.

The isolators should be at equal height during fan operation. Center the fan outlet in the outlet panel opening. If adjustment is required, loosen the cap screw on top of the isolator assembly. Turn the adjustment nut below the fan frame to lower or raise the fan motor and frame assembly. Retighten the cap screw on top of the isolator assembly. See Figure 41.

**Figure 41: Adjusting Spring Mount Assembly (Class 1 & 2)**

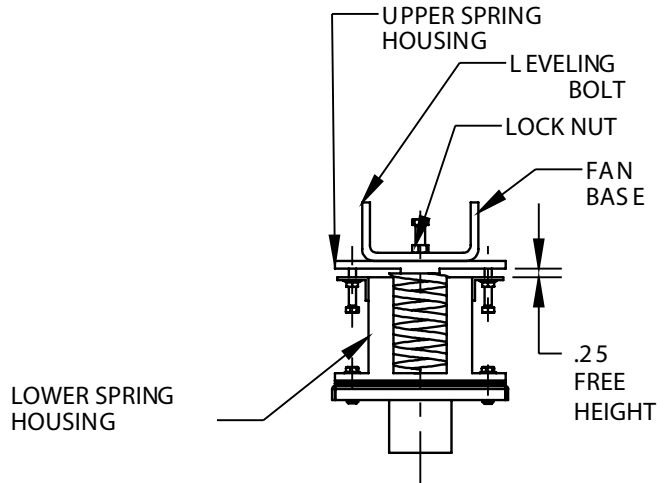


### Spring Mount Assembly (Class 3)

Before operation, Class 3 isolators should be adjusted as follows:

1. Loosen the locknut on each of the four spring mount assemblies.
2. Adjust each of the four leveling bolts in order to level the fan assembly. The gap between each upper and lower spring housing should be approximately 1/4".
3. After all four springs are adjusted, tighten the locknut located on each leveling bolt.
4. Turn the adjustable vertical restraint nuts until finger tight.

**Figure 42: Adjusting Spring Mount Assembly (Class 3)**



# Electrical Installation

## Wiring

### DANGER

**Capacitor Hazardous Voltage!** Failure to disconnect power and discharge capacitors before servicing will result in serious injury or death.

Disconnect all electric power (including remote disconnects) before servicing. Perform lockout/tagout procedures to ensure that power can not be energized. For variable frequency drives, or other energy storing components that have been furnished and mounted by either Daikin Applied, or by others, refer to the specific manufacturer's literature for allowable waiting periods for discharge of capacitors. Verify capacitors have been discharged using an appropriate voltmeter.

### DANGER

- This equipment is not suitable for use in high impedance grounding or neutral systems.

- Connect only to low impedance, solidly grounded electrical supply systems.

Failure to follow these instructions will result in death or serious injury.

### CAUTION

**Use copper conductors only!** Failure to use copper conductors can result in equipment damage.

- Control panel includes the type and rating of fuses and circuit breakers.
- Electrical wiring diagrams are provided with equipment.
- Electrical enclosures contain information regarding purpose, voltage, current, and construction safety class.
- Electrical service to each fan must correspond to the rated voltage on the motor or electrical panel nameplate and conform to the National Electric Code and local restrictions.
- Connect each fan section metal frame to the building electrical ground.
- A door electrical interlock is not provided as standard.
- Thermal motor protection is external to the unit. Unless the unit is provided with a variable frequency drive (VFD) or a unit mounted starter, thermal protection and a disconnect switch provision per electric codes are provided by others.
- When the unit is factory provided with a disconnect switch, starter or a variable frequency drive (VFD), the components are mounted on the outside of the unit cabinet. Factory wiring is provided from the device to the unit internal motor.
- All electrical components must be grounded to the building central ground. Suitable ground wires and/or (bonding) lugs are provided for all motors, disconnect switches, starters, and variable frequency drives. Provide dedicated ground (bonding) copper conductors in accordance with local and national codes.
- For units provided with a motor only or with an external junction box, wire connections are made with suitable wire nuts or connectors for the gauge wires provided.
- For units provided with a disconnect switch or starter, field

wiring will be terminated to lugs. Wire size and lug torque requirements are shown on the unit electrical schematic provided in the component print pocket. All power supply wire connections must be torqued as shown.

- When the unit is provided with a VFD only, refer to the VFD manual for wire size and torque requirements. For instances where multiple motors are being driven by a single VFD, be sure to set up the VFD and size the wiring according to the power requirements of all motors that are being driven by that VFD.
- When not being serviced, close and secure electrical panel doors to prevent ingress of moisture and airborne contaminants.

## Control Wiring

- Access to the VFD is through the fan cabinet access door for single fans. Provide shielded cable only as described in the provided VFD manual. Route wire through the panel ([Figure 15 on page 13](#)) so that it does not interfere with other components or access doors. Do not drill through drip pans or drain pans. Refer to the provided VFD installation manual for detailed control wiring instructions.
- For multiple fans in parallel, the VFD(s) are mounted inside of the electrical enclosure, which is mounted on the exterior of the fan section. When multiple fan sections are provided with multiple VFDs, they must be set up so that the fans always start simultaneously and are set to ramp up and down together. Do not attempt to run fans in parallel at different speeds as this can result in uneven airflow that can cause performance, sound, and vibration problems that can lead to failure. Provided that the fan is capable of running fast enough, the motor is sized appropriately, and the VFD can be sped up within its rated continuous output, VFDs may be operated up to a maximum recommended frequency of 90 Hertz for 1800 RPM and slower motors. Motors that are 3600 RPM may be operated up to a maximum speed of 4000 RPM or 66.7 Hertz provided the fan is rated that high. Operation above 4000 RPM can damage motor bearings and is not recommended.

## Wiring Penetrations

- Seal any panel penetrations for wiring or conduit per the panel cutting procedure instructions within this document.
- Seal any other wiring or conduit penetrations in accordance with NEC, relevant codes, and in order to maintain the enclosure rating, only use fittings that are approved to keep the particular rating of the individual enclosure being penetrated per relevant code or standard tables. Seal wireway openings tight enough to prevent air movement between sections and control enclosures.

# Operation Guidelines

## Startup Checks

 **WARNING**

**Rotating fan.** Can cause severe injury or death. Before servicing fans, lockout and tag out power.

 **WARNING**

**Fire/electric shock hazard.** Can cause property damage, personal injury or death. Wire fan power supply and ground motor frame in accordance with local electric codes.

 **WARNING**

**Fan motor requires overload protection.** Failure to provide motor overload protection can result in fire, property damage, electric shock, person injury, or death. Connect motor to an overload protective device rated in compliance with local electric codes.

 **CAUTION**

**Do not overheat fan motor.** High air temperatures in the fan section can cause the fan motor to burnout. On draw-through air handlers or air handlers with the fan section down the air stream from the heating section, the discharge air temperature of the heating section must not exceed 104°F (40°C).

 **CAUTION**

Equipment damage to loose fasteners represents improper start-up and equipment abuse. It is not covered by the warranty.

 **WARNING**

Maximum operating altitude should not exceed 15,000 feet.

When performing startup and service, always follow safety precautions. Only trained, experienced personnel should perform these functions.

## Before Starting the Unit:

Before entering fan section, make sure that fan electrical power source is disconnected and locked in the OFF position.

1. Check that the unit is completely and properly installed with ductwork connected.
2. Check that construction debris is removed/filters are clean.
3. Check that all electrical work is complete and properly terminated.
4. Check that all electrical connections are tight and that the proper voltage is connected. Phase imbalance must not exceed 2%.
5. Do not grease ball bearings on the fan shaft and motor before startup. They are pre-lubricated.
6. Check tightness of setscrews in bearings and fan wheel(s). If retightening is needed, position the fan wheel(s) per [Table 20 on page 30](#) through [Table 25 on page 32](#). Torque set screws per [Table 26](#) and [Table 27 on page 32](#).
7. Check alignment of fan and motor sheaves and belt tension. Adjust if necessary. Check tightness of sheave setscrews and/or capscrews. See [Figure 78](#).
8. Leak test the thermal system to verify connections are tight.
9. Check that the condensate drain is trapped.
10. Rotate the shaft by hand to be sure it is free.
11. If multiple fans are supplied with a block off plate and it is installed on one of the fans, make sure to only start the fans without the block off plate. Do not start any fan that has the block off plate installed on it.
12. If multiple fans are supplied with isolation dampers, make sure the isolation dampers are fully open before starting the fans.
13. If applicable, verify installation requirements have been followed for A2L refrigerants. See [page 47](#) for guidance.

## VFD Setup

Fans ordered with VFDs that were factory installed are setup and tested prior to shipment. Prior to starting the fan(s), double check the VFD settings according to the recommendations in the VFD manual.

Once the correct VFD settings are verified, the fans should be run through a sweep of the full range of operating speeds that are expected to check for any vibration issues. If any areas of concern are located, it is recommended to lock out those frequencies using the VFD (see lock out frequencies or skip frequencies in the VFD manual). This will ensure that the fans will never operate continuously at those points, but will rather pass through them to get to the desired points of operation.

## Fan Startup

Start and run fan. See Figure 47 for proper fan rotation. Observe the rotation. If the fan operates backward, reverse two legs of the three-phase supply power.

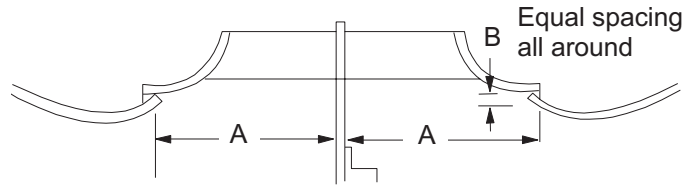
**NOTE:** Variable pitch fan drives usually are provided for operation in the mid-speed adjustment range. However, the drives usually ship with the adjustment opened up for minimum fan speed. Adjust the drives for the proper airflow. See Fan Drive Adjustments on page 61.

### After the First 48 Hours of Operation:

1. Disconnect and lock electrical power source.
2. Check tightness of all bearing, wheel, and sheave setscrews (or capscrews). See Table 27.
3. Recheck belt tension and adjust if necessary, retaining sheave alignment. Belts tensioned sufficiently to slip one to two seconds at startup will perform satisfactorily, extending life and reducing vibration.

## Fan Wheel Alignment

**Figure 43: Wheel-to-Inlet Funnel Relationship (Airfoil Type Fan Wheels (Housed))**

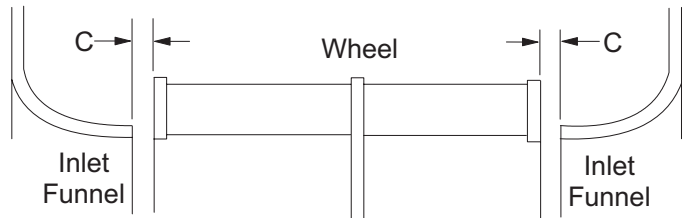


**Table 20: Wheel-to-Inlet Funnel Relationship (Airfoil Type)**

Diameter (in.)	A in. (mm)	B in. (mm)
20.00	7.19 (183)	0.31 (7.87)
22.25	7.69 (195)	0.33 (8.38)
24.50	8.56 (217)	0.31 (7.87)
27.00	9.47 (241)	0.63 (16.0)
30.00	10.47 (266)	0.39 (9.91)
33.00	11.75 (298)	0.38 (9.65)
36.50	12.78 (325)	0.38 (9.65)
40.25	14.31 (363)	0.5 (12.7)
44.50	15.65 (398)	0.56 (14.22)
49.00	17.44 (443)	0.61 (15.49)

**Note:** 1. To obtain rated air performance, dimensional relationship must be held.  
**Note:** 2. To obtain dimension A, loosen setscrews in wheel hub(s), shifting wheel(s) axially as needed, retightening setscrews.  
**Note:** 3. To obtain dimension B, loosen screw and washer fasteners around periphery of funnel(s), shifting funnel radially as required, re-torquing fasteners.

**Figure 44: Wheel-to-Inlet Funnel Relationship (Forward Curved Type Fan Wheels)**

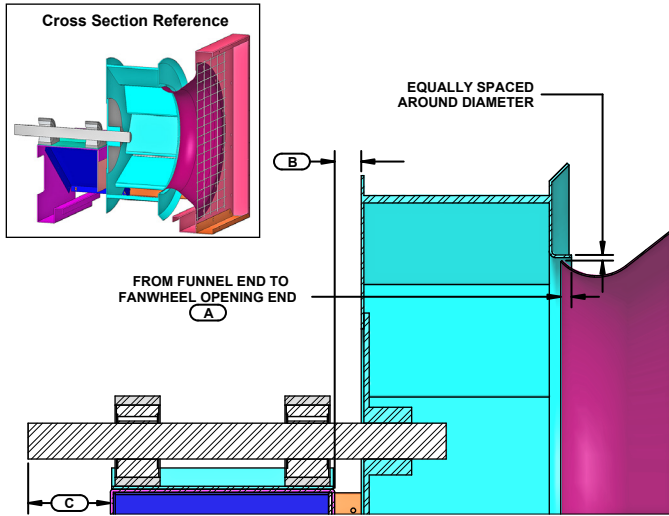


**Table 21: Wheel-to-Inlet Funnel Relationship (Forward Curved Type Fan Wheels)**

Diameter (in.)	C in. (mm)
20 (Class 1 & 2)	0.24 (6.10)
22.38 (Class 1 & 2)	0.41 (10.41)
25 (Class 1 & 2)	0.47 (11.94)
27.62 (Class 1 & 2)	0.47 (11.94)
30 (Class 1 & 2)	0.47 (11.94)
33 (Class 1 & 2)	0.50 (12.70)
36 (Class 1 & 2)	0.75 (19.05)

**Note:** 1. To obtain rated air performance, dimensional relationship must be held.  
 — Adjust dimension C by loosening wheel hub setscrews, shifting wheel(s) axially as needed, and retightening setscrews.

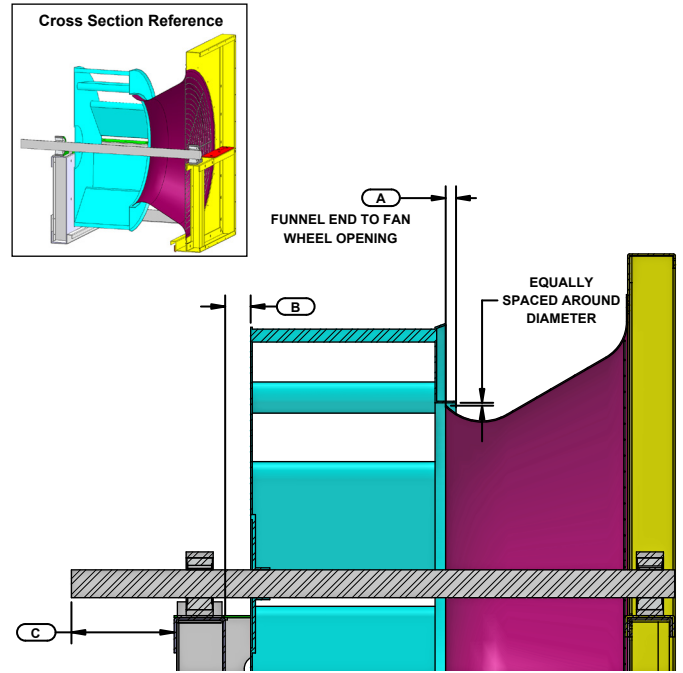
**Figure 45: Wheel-to-Inlet Funnel Relationship  
(18 to 36 Belt-Drive Plenum Fans)**



**Table 22: Wheel-to-Inlet Funnel Relationship  
(18 to 36 Belt-Drive Plenum Fan)**

Wheel-Funnel Parameters			
Size	A	B	C
18	0.38	0.86	3.88
20	0.42	1.11	3.88
22	0.45	1.11	3.88
24	0.51	1.11	3.88
27	0.55	1.36	4.5
30	0.62	1.36	4.5
33	0.55	1.5	5.0
36	0.63	1.5	5.0

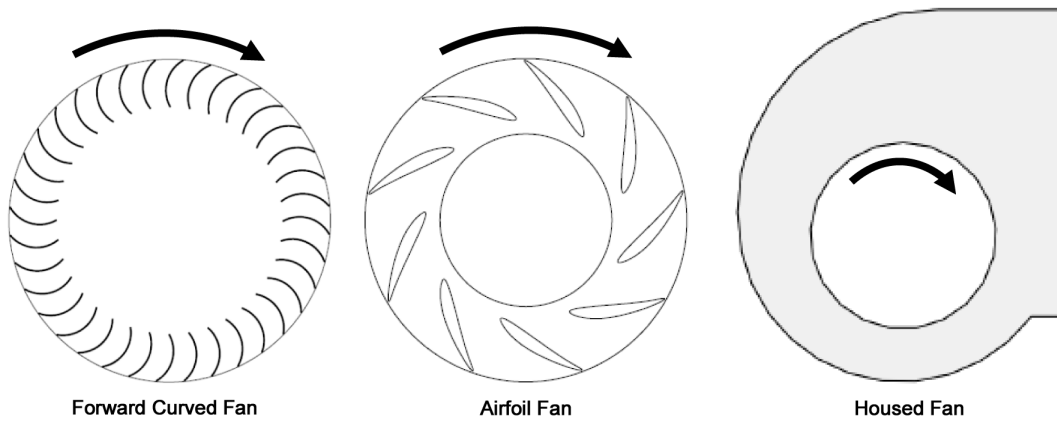
**Figure 46: Wheel-to-Inlet Funnel Relationship  
(40 to 60 Belt-Drive Plenum Fans)**



**Table 23: Wheel-to-Inlet Funnel Relationship  
(40 to 60 Belt-Drive Plenum Fan)**

Wheel-Funnel Parameters			
Size	A	B	C
40	0.82	2.00	4.88
44	0.91	2.25	5.50
49	1.00	2.50	5.50
54	1.10	2.50	5.50
60	1.23	3.00	5.50

**Figure 47: Fan Wheel Rotation**



Fan wheel should rotate as shown

**Table 24: Wheel to Inlet Funnel Relationship (Direct-Drive Class II Fans)**

Fan Size	Overlap (in.)
18	0.38
20	0.41
22	0.45
24	0.50
27	0.55
30	0.61
33	0.67
36	0.75
40	0.82
44	0.91

**Table 25: Wheel to Inlet Funnel Relationship (Direct Drive Class III Fans)**

Fan Size	Overlap (in.)
18	0.31
20	0.38
22	0.44
24	0.50
27	0.55
30	0.62
33	0.75
36	0.81
40	0.88
44	0.94
49	1.0
54	1.06
60	1.12

**Table 26: Setscrew Torque Specifications (Class II Plenum Fans Only)**

Fan Size	Setscrew Size	Torque (ft.-lb)	
		Aluminum	Steel
18	3/8	19.2	N/A
20	3/8	19.2	N/A
22	3/8	19.2	N/A
24	3/8	19.2	N/A
27	3/8	19.2	22
30	1/2	41.7	55
33	1/2	41.7	55
36	1/2	41.7	55
40	1/2	41.7	55
44	1/2	41.7	55
49	1/2	41.7	55
54	1/2	41.7	55
60	3/4	115	150

**Table 27: Bearing Collar and Wheel Hub Set Screw Torque (all fans except Class II plenum fans)**

Set Screw Diameter (in)	Minimum torque
	ft/lbs (kg/m)
1/16	5.5 (0.76)
1/4	10.5 (1.45)
3/8	19.0 (2.63)
7/16	29.0 (4.01)
1/2	42.0 (5.81)
5/8	92.0 (12.72)

# Daikin Applied Fan Array

**WARNING**

Closing the damper on an operational fan could send the fan into surge that could produce fans stall, excessive vibration, unit damage, or personal injury.

The Daikin Applied Fan Array is available with optional, factory mounted VFDs. See OM manuals OM 1190 and 1191 for details on the Daikin Applied supplied VFD.

Care should be taken when programming and synchronizing the drives in the Daikin Applied Fan Array such that all fans turn at the same speed. Fans running at unequal speeds can produce vibration and could stall a fan. Definition of fan numbering is given in Figure 48.

The Daikin Applied Fan Array is standard with a manual block off plate. The unit will ship with one block off plate that will come installed on fan 1A. This block off plate is to be removed before unit operation and stored outside of the air tunnel. In the event of a lost fan motor, the block off plate is installed on the non-functional fan to prevent air re-circulation. This is designed to be a temporary measure until this fan and/or motor is replaced. After fan and/or motor replacement the block off plate is to be removed and stored outside of the air tunnel.

The Daikin Applied Fan Array has an optional gravity actuated block off damper. These dampers are equipped with counter weights.

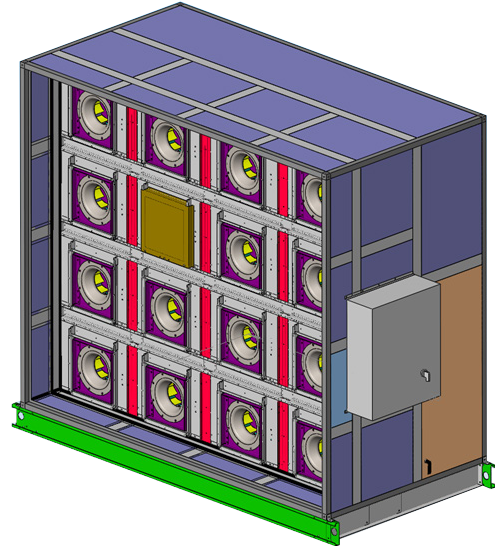
The Daikin Applied Fan Array has an optional actuated block off damper. These dampers are designed to prevent air recirculation in the event of a lost fan. Care should be taken that the damper actuator only be given a close signal if the fan is not operational (motor burnout for example).

The Daikin Applied Fan Array can be equipped with a fan blank off plate. See Figure 49 with a block off plate mounted to fan 3C. If the unit is ordered with the manual block off plate, it will be installed to fan 1A. This plate has to be removed before start up.

**Figure 48: Daikin Applied Fan Array Configuration**

6D	5D	4D	3D	2D	1D
6C	5C	4C	3C	2C	1C
6B	5B	4B	3B	2B	1B
6A	5A	4A	3A	2A	1A
Viewed from Fan Inlet End					

**Figure 49: Fan Array with Block Off Plate**



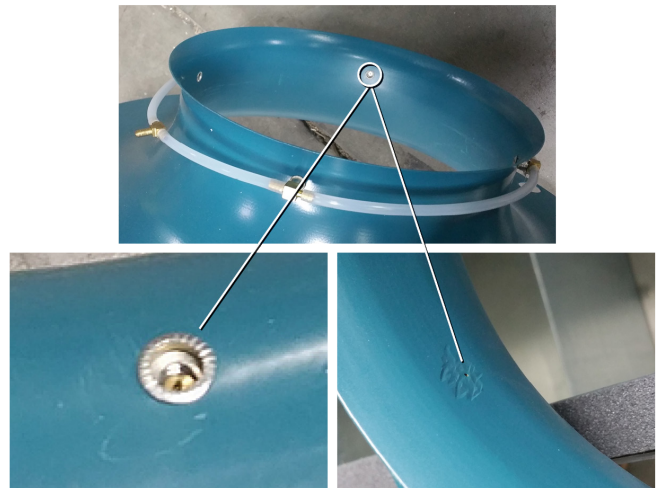
## Optional Piezometer Ring Airflow Measurement Device

Piezometer rings are available as an option on direct drive plenum fans to measure airflow through the fan. The device consists of a piezometer ring mounted in the throat of the funnel and a static pressure tap mounted near the inlet of the funnel. The pressure drop is measured from the tap located near the inlet of the funnel to the piezometer ring in the throat. The inlet tap is connected to the high-pressure side of the transducer and the piezometer ring is connected to the low-pressure side.

See the equations and factors required to calculate flow using the piezometer ring.

**NOTE:** There are two manufacturer options for the piezometer ring. Care should be taken to ensure that the appropriate coefficients are used, otherwise airflow measurement may be incorrect. Reference Figure 50 to determine which piezometer ring you have.

**Figure 50: Determining the Manufacturer**



Daikin Applied Piezo Ring

TCF Piezo Ring

### Non-Standard Density Method

The following equation is used to measure the flow for non-standard density:

$$ACFM = C1 \times A \times \sqrt{(\Delta P/\rho)}$$

where: A = Inlet funnel throat area (square feet) - from [Table 29](#) and [Table 31](#)

$\Delta P$  = The differential in static pressure from the piezometer ring and the inlet pressure tap (inches w.g.)

$\rho$  = Air density (pounds mass/cubic foot)

C1 = Value from [Table 28](#) and [Table 30](#)

### Standard Density Method

The equation can be simplified by assuming standard density and assuming funnel dimensions match the drawing dimensions. [Table 29](#) and [Table 31](#) show the factor (K) for each fan size and type. The equation then becomes the following:

For standard air ( $\rho = 0.075 \text{ lb/ft}^3$ ):

$$ACFM = K \times \sqrt{(\Delta P)}$$

where: K = factor from [Table 29](#) and [Table 31](#)

$\Delta P$  = The differential in static pressure from the piezometer ring and the front pressure tap (inches w.g.)

**Table 28: DDPL Factors For Free and Ducted Inlet — Non Standard Density Method, TCF Piezo Ring**

Product	C1 Free Inlet	C1 Ducted Inlet
DDPL Size 11-16	753.06	794.06
DDPL Size 18-44	692.03	740.14

**Table 29: DDPL Factors For Free and Ducted Inlet — Standard Density Method, TCF Piezo Ring**

DDPL Size	Free Inlet K	Ducted Inlet K	Area A	Wheel Diameter
11 and 12	944.92	996.36	0.344	12.40
15	1206.40	1272.08	0.439	14.00
16	1518.58	1601.26	0.552	15.75
18	1821.92	1948.58	0.721	18.25
20	2185.80	2337.76	0.865	20.00
22	2713.93	2902.60	1.074	22.25
24	3285.02	3513.39	1.300	24.50
27	3997.61	4275.53	1.582	27.00
30	4945.21	5289.01	1.957	30.00
33	5968.62	6383.56	2.362	33.00
36	7290.21	7797.03	2.885	36.50
40	8869.55	9486.16	3.510	40.25
44	10827.92	11580.68	4.285	44.50

**Table 30: DDPL Factors for Free and Ducted Inlet – Non-Standard Density Method, Daikin Applied Piezo Ring**

DDPL Size	C1 Free Inlet	C1 Ducted Inlet
12	783.66	792.43
15	767.48	763.62
16	732.77	757.40
18	612.29	619.65
20	653.83	652.65
22	674.42	673.16
24	679.53	681.34
27	656.57	660.15
30	691.07	692.12
33	675.26	677.89
36	675.83	676.67
40	699.51	694.22
44	681.07	681.01

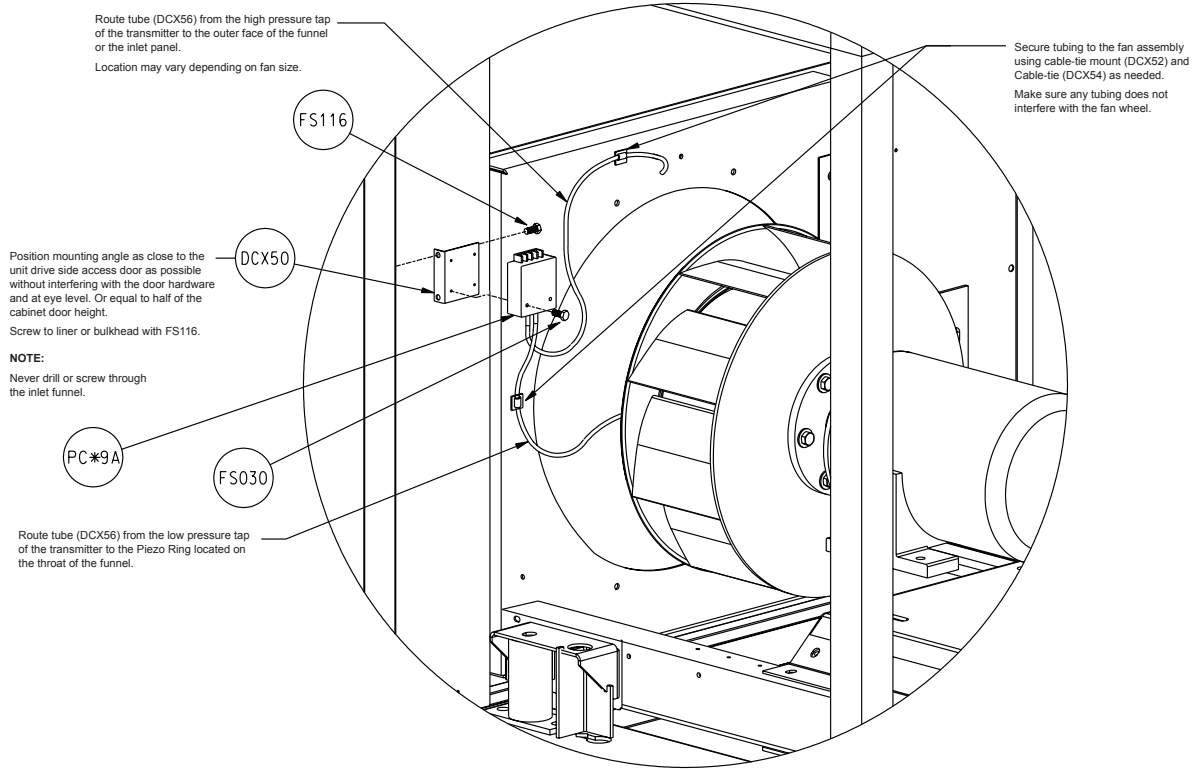
**Table 31: DDPL Factors for Free and Ducted Inlet – Standard Density Method, Daikin Applied Piezo Ring**

DDPL Size	Free Inlet K	Ducted Inlet K	Area A	Wheel Diameter
12	1004.66	1016.46	0.344	12.40
15	1261.99	1260.20	0.439	14.00
16	1526.96	1572.35	0.552	15.75
18	1675.69	1672.77	0.721	18.25
20	2117.33	2110.61	0.865	20.00
22	2710.75	2693.35	1.074	22.25
24	3312.67	3319.41	1.300	24.50
27	3901.60	3929.94	1.582	27.00
30	5017.64	5033.71	1.957	30.00
33	5942.72	5979.46	2.362	33.00
36	7274.52	7316.07	2.885	36.50
40	9179.91	9089.14	3.513	40.25
44	10891.71	10880.24	4.285	44.50

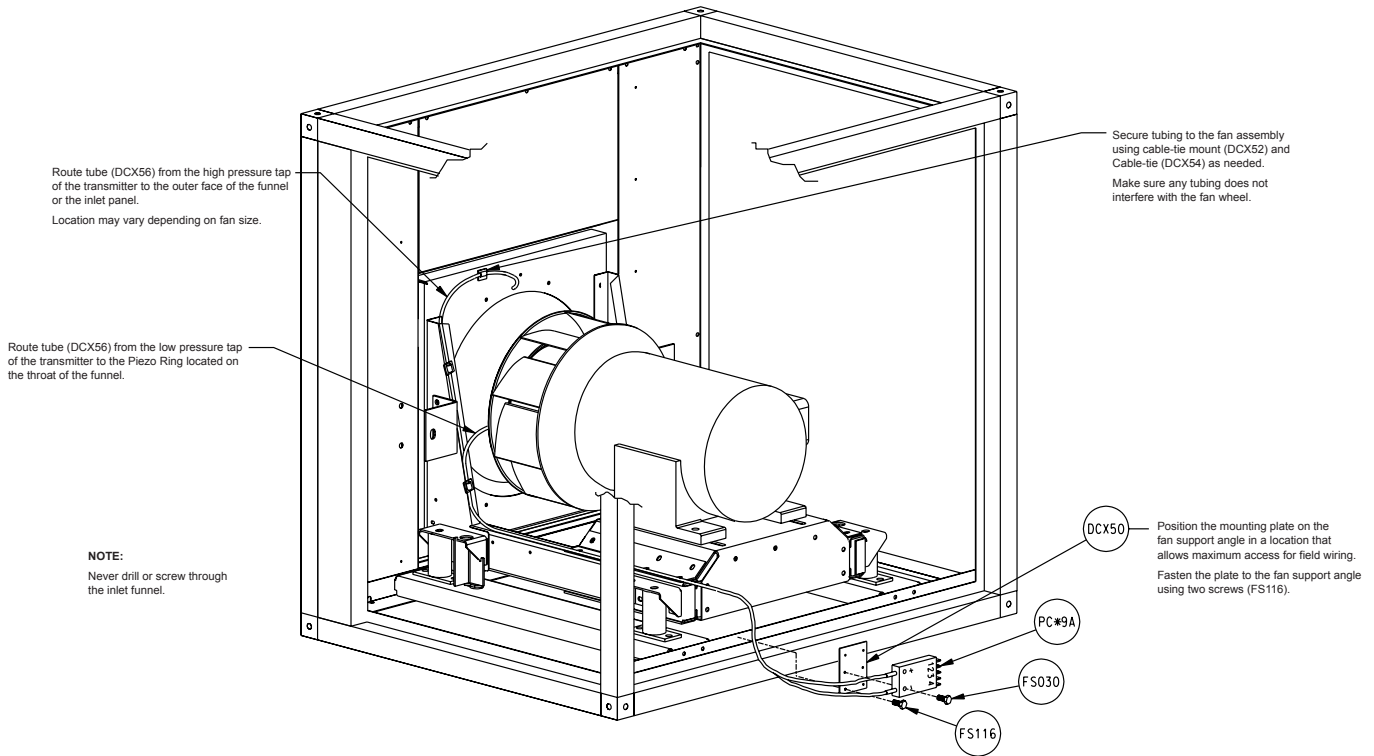
### Optional Transducer for Piezometer Rings

A transducer is available for Piezometer rings. Factory mounting locations for the fan transducer is shown in [Figure 51](#) for direct-drive plenum fans. [Figure 52](#) shows the installation for fan array. Wiring for the transducer is field-supplied and installed.

**Figure 51: Direct-drive Plenum Fan Installation**



**Figure 52: Fan Array Installation**



## Daikin Applied ECM Fan Array

The Daikin Applied ECM fan array is made of an impeller, an electronically commutated motor (ECM), and an inverter. It is installed as an assembly, and in the event of failure, the entire assembly must be replaced. Bearings are permanently sealed and lubricated, so no periodic greasing is necessary.

A minimum 24" access section is recommended downstream of the Daikin Applied ECM Fan Array section to gain access to the fans. If an access section is not selected downstream of the fan array, there will be very limited access to the fans for service/replacement.

The Daikin Applied ECM fan array has an optional gravity actuated block off damper. These dampers are equipped with counter weights.

The Daikin Applied ECM Fan Array has an option for a block off plate that can be ordered as a parts kit from the Daikin Applied Parts group. A minimum 24" access section is recommended upstream of the Daikin Applied ECM Fan Array section to install block-off plate (see [See Block-Off Plate Installation on page 38](#)).

### ECM Control Options

1. ANALOG CONTROL
  - i. None: 0-10V speed control.
  - ii. Basic: 0-10V speed control with HOA (manual/auto) switch and potentiometer.
2. DIGITAL CONTROL
  - i. Premium controls: MicroTech unit controller with Modbus.

The entire array is controlled via a 0-10V signal for analog controls. The control signal (0-10V) is wired to the Daikin Applied low voltage terminal block (TB01) and connects to points as noted in schematics shown in [Figure 60 through Figure 67](#).

**NOTE:** Fans may continue to draw electrical current when not in operation.

**NOTE:** The Daikin Applied ECM Fan Array control schematic is included in the ECM fan control panel.

The digital controls option is a DDC controller allowing for equipment configuration, monitoring, and troubleshooting. The controller is either factory installed on the unit or remote mounted.

### Example:

A Delta fan motor with "Basic" controls connects the control signal to points 2 and 4 on the Daikin Applied low voltage terminal block (TB01). Fan enable is controlled by a field supplied relay and connects to points 1 and 3. The fan array fault is wired to points 5 and 6. If any fan in the fan array faults, the contact connection between 5 and 6 will open.

**NOTE:** If an enable relay is not needed, add a jumper at point 1 and 3.

## Remote Mounted Panel

The control panel can be ordered for remote mounting. For remote mounted panels, the control wiring for the individual fans will be provided; however, the control wiring to connect the final fan to the control panel and all of the power wiring must be field-provided. If control panel is too heavy to be mounted on unit then it will be shipped separately and must be remote mounted.

30 foot long high voltage harnesses may be ordered through the Daikin Applied Parts Group using part number 910232406. One high voltage harness is required per fan.

If wiring harnesses are not purchased through Daikin Applied, follow the below instructions to install the wiring.

1. High Voltage Power Wiring:
  - a. Remove the plate on the back of each fan.
  - b. Remove the provided high voltage plug and wiring shown in [Figure 53](#).
  - c. Cut, strip, and connect wiring directly to each motor terminal shown in [Figure 53](#), paying attention to the correct phasing. Reference the wiring schematic provided with unit. Wiring to be in accordance with NEC.
  - d. Cut, strip, and connect the other end of the wiring to the Manual Motor Protector (MMP) in the control panel, paying attention to phasing. Reference the wiring schematic provided with unit.

**NOTE:** [Figure 54](#) shows a single fan control box. There will be 1 MMP per fan in the array to connect each fan to.

2. Low Voltage Control Wiring:
  - a. Verify same plugs and terminals are used for all control options and fan types.
  - b. 22-gauge Cat5 wiring, a standard 6-circuit female Molex plug (39-01-2061), and six Molex crimp terminals (39-00-0040) are required ([Figure 55](#)). The finished harness will have a plug on one end and stripped wire on the other end.
  - c. Attach the wiring to the Molex crimp terminal and insert into the Molex plug. See [Figure 56](#) for correct crimp terminal locations; reference schematic shipped with unit for wiring numbers (out of ECM01). Connect to the male plug that is on the last fan in the array.
  - d. Insert the stripped wire end into the terminals in the control panel, following the wiring diagram shipped with unit. Terminals are shown in [Figure 54](#).

Figure 53: Fan - High Voltage Wiring

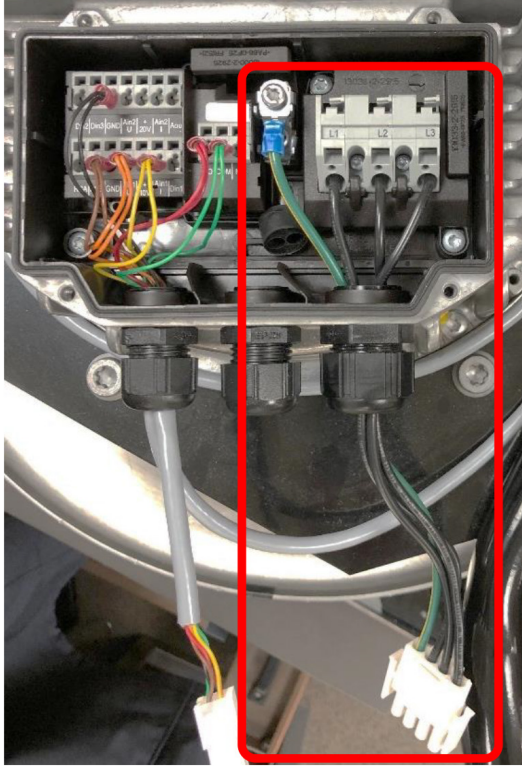


Figure 54: Single Fan Control Panel - High Voltage Wiring (in red); Low Voltage Wiring (in blue)

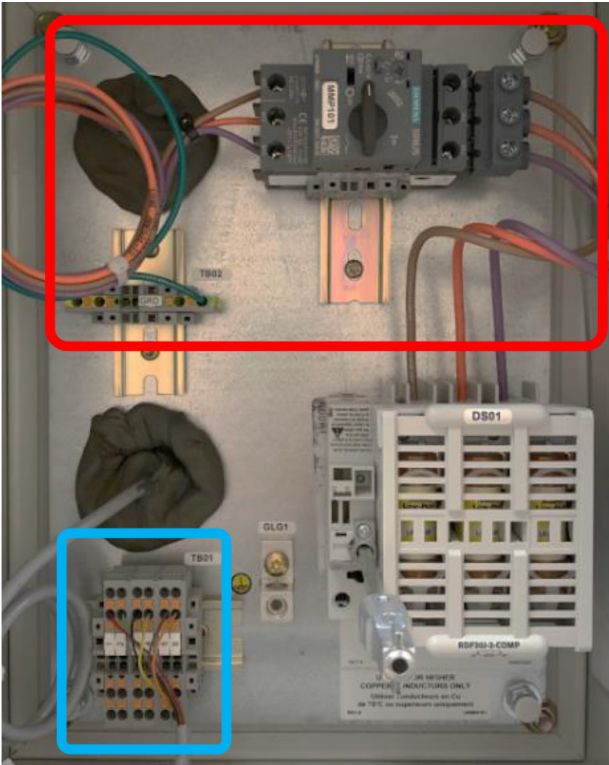


Figure 55: Required Molex Plug and Crimp Terminals

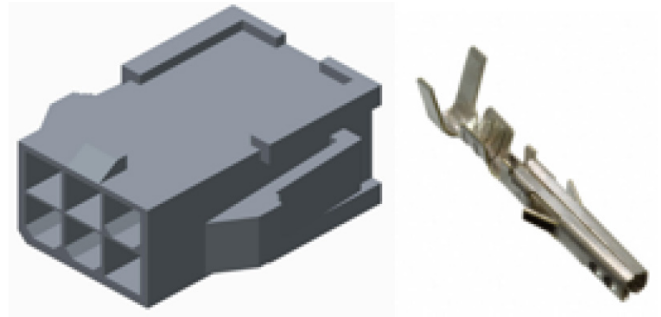


Figure 56: Molex Plug Crimp Terminal Locations

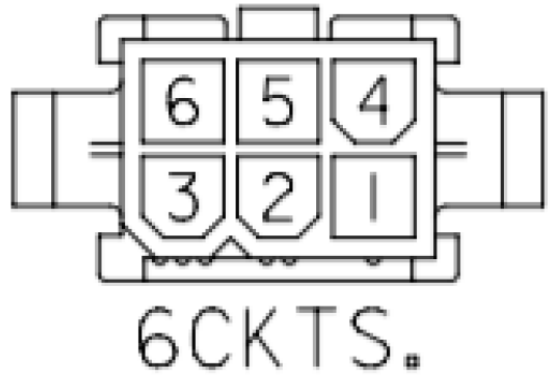
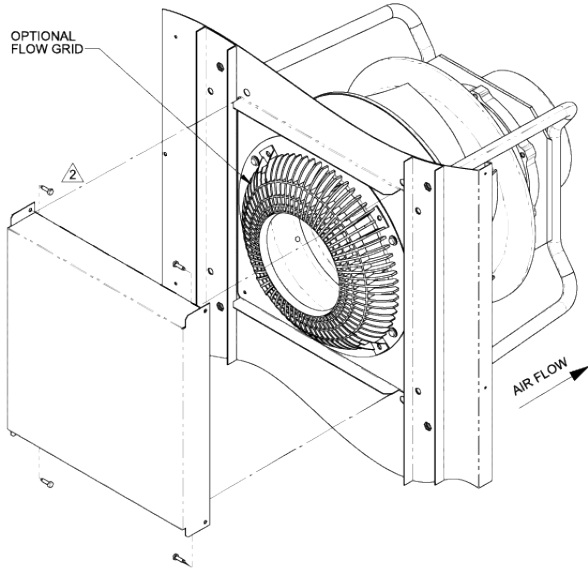


Figure 57: Daikin Applied ECM Fan Array



Figure 58: Block-Off Plate Installation



NOTES:  
 1) INSTALL BACK-DRAFT PANEL AS SHOWN OVER NON-FUNCTIONING FAN  
 2) SECURE USING (4) SELF DRILL/TAPPING SCREWS

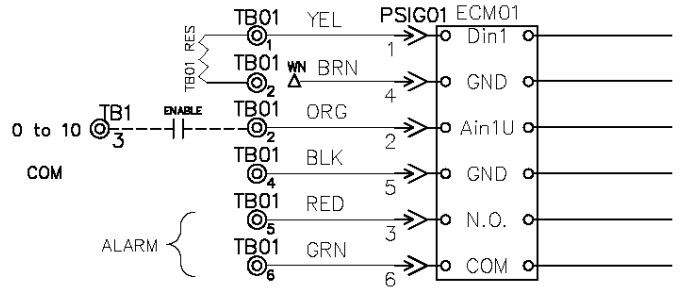
Table 32: Block-Off Plate Part Numbers

Block-Off Plate	Fan Size	kW
910198700	355	All
910198701	450	All
910311272	560	All
910311272	630	5.9; 6.3
910311273	630	7.1; 9.8

Figure 59: EBM Gen 2 Motor

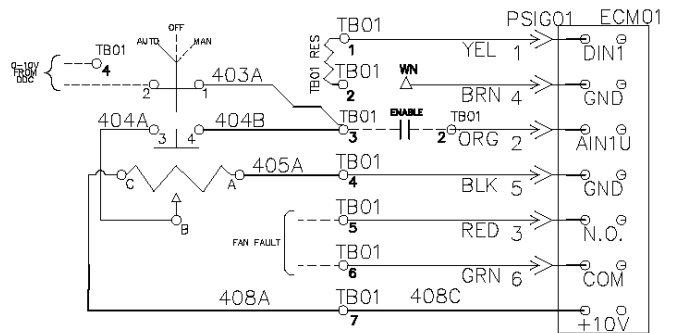


Figure 60: EBM Gen 2 Motor - Control Wiring with No Controls



NOTE: TB01 RES only used for fan QTY 2-5

Figure 61: EBM Gen 2 Motor - Control Wiring with Manual/ Auto (Basic) Controls



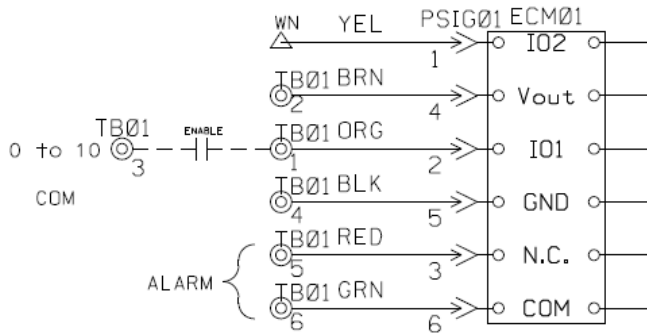
NOTE: TB01 RES only used for fan QTY 2-5

NOTE: For ECM Fan DDC controller information and wiring, reference ED 19123.

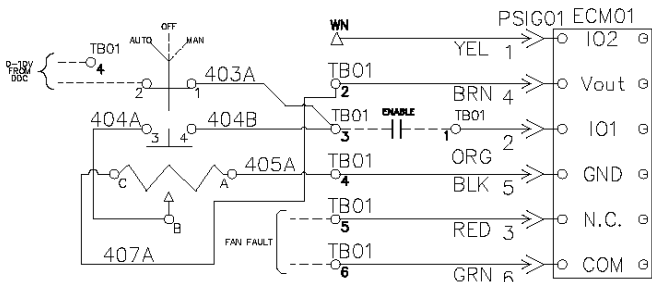
Figure 62: EBM Gen 3 Motor



**Figure 63: EBM Gen 3 Motor - Control Wiring with No Controls**

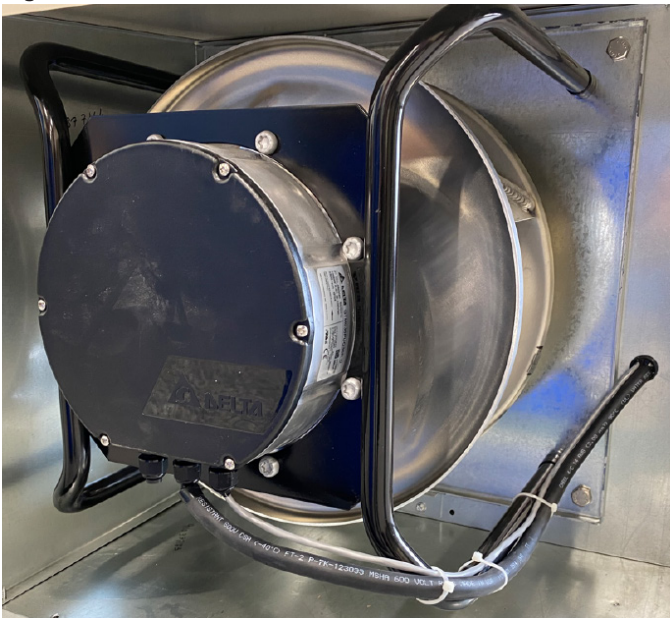


**Figure 64: EBM Gen 3 Motor - Control Wiring with Manual/Auto (Basic) Controls**

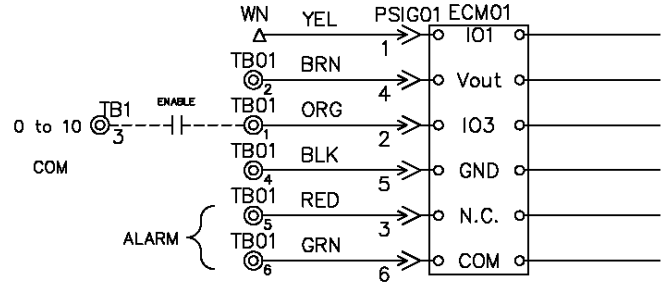


**NOTE:** For ECM Fan DDC controller information and wiring, reference ED 19123.

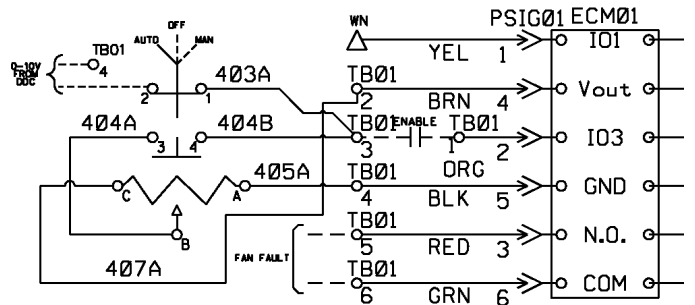
**Figure 65: Delta Motor**



**Figure 66: Delta Motor - Control Wiring with No Controls**



**Figure 67: Delta Motor - Control Wiring with Manual/Auto (Basic) Controls**



**NOTE:** For ECM Fan DDC controller information and wiring, reference ED 19123.

Figure 68: Line Voltage Wiring - All Fans

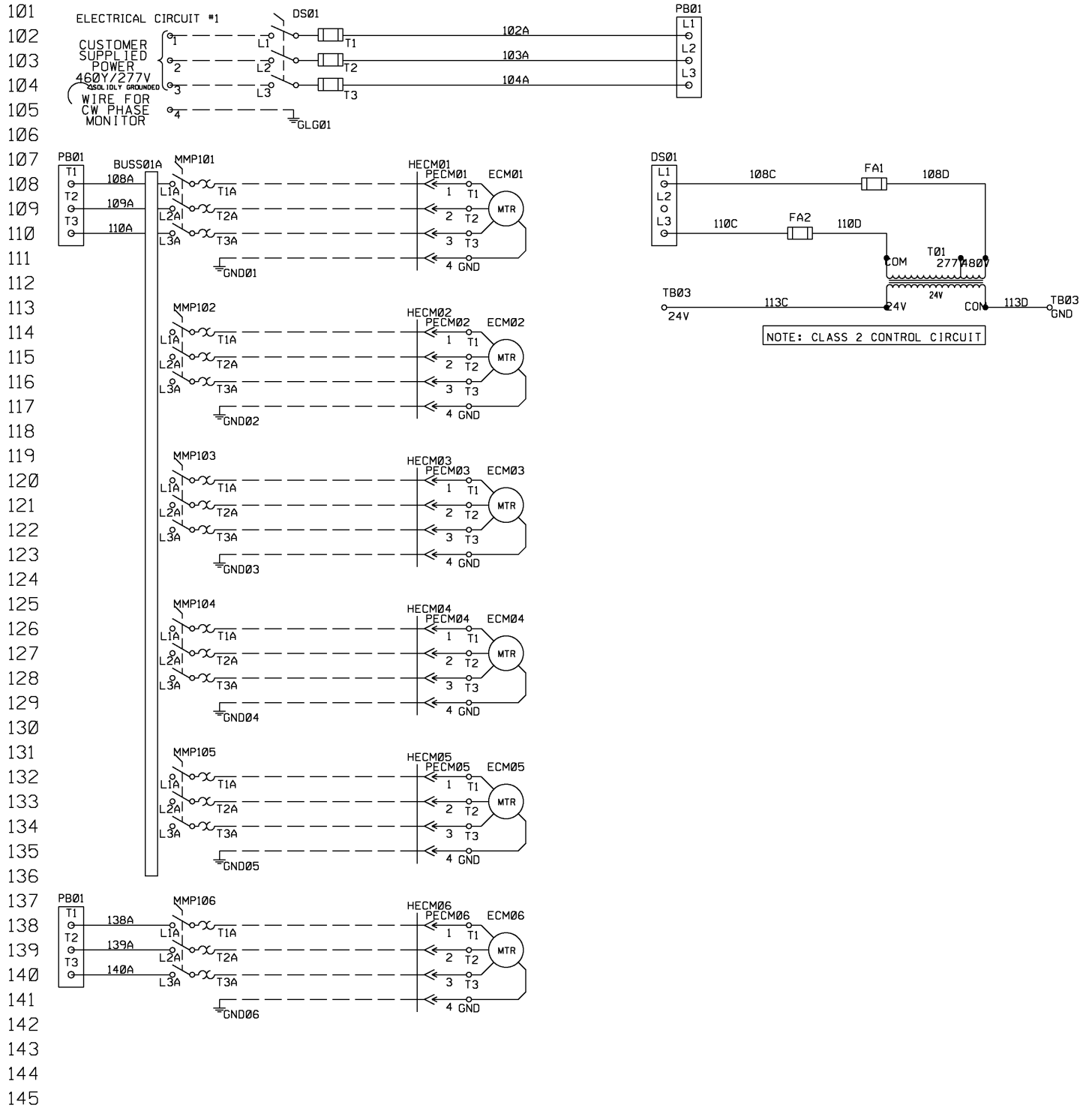
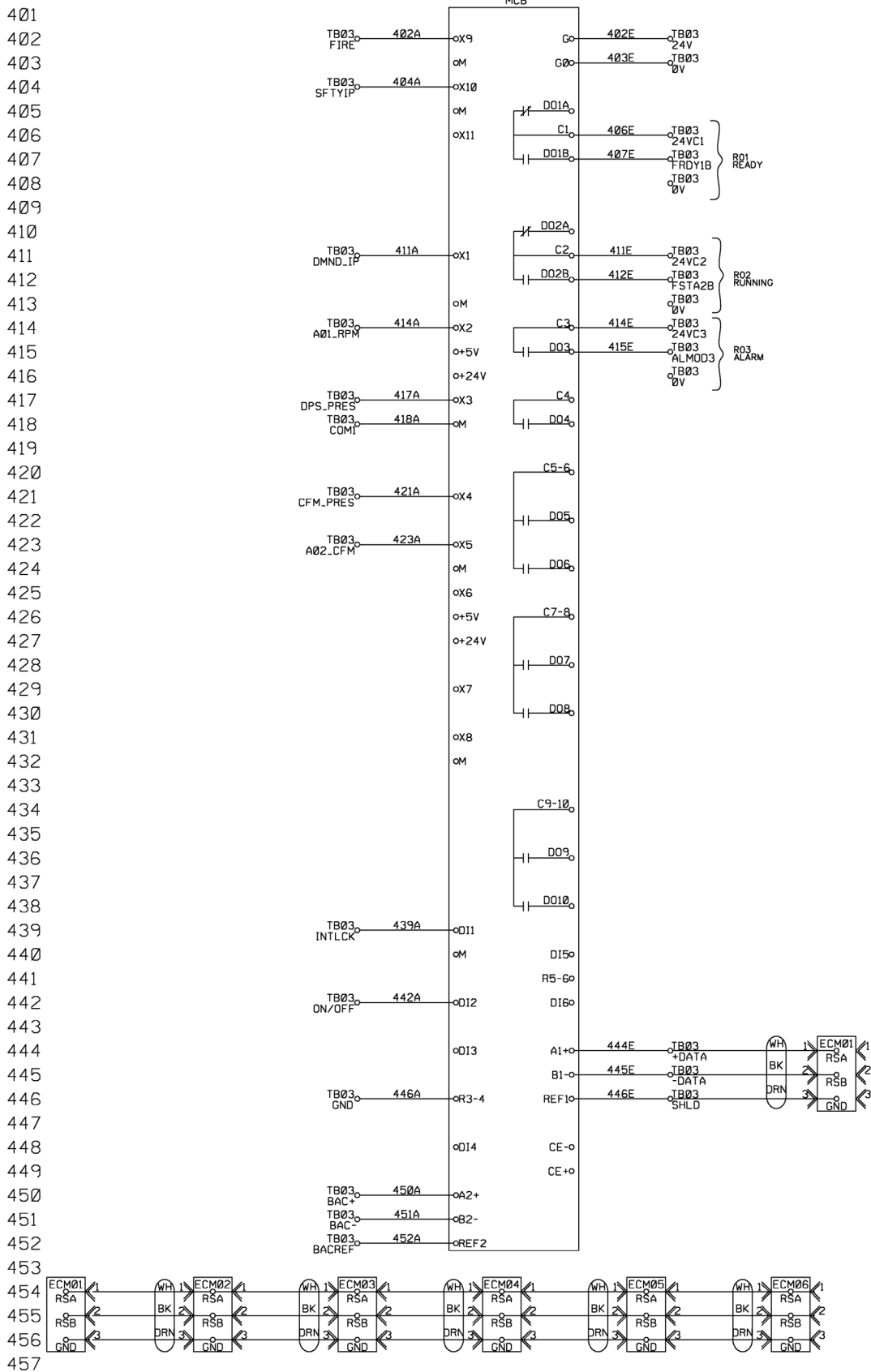


Figure 69: Line Voltage Wiring - All Fans



## Optional Piezometer Point Airflow Measurement Device

A Piezometer point is an option with ECM Fans to measure airflow through the fan. The device consists of a piezometer point mounted in the throat of the funnel and a static pressure tap mounted near the inlet of the funnel. The pressure drop is measured from the tap located near the inlet of the funnel to the piezometer point in the throat. The inlet tap is connected to the high-pressure side of the transducer and the piezometer point is connected to the low-pressure side.

A transducer is always factory supplied when the Piezometer Option is selected with an ECM Fan. Figure 70 shows the installation for ECM Fans.

See the equations and factors required to calculate flow using the piezometer point:

### Non-Standard Density Method

The following equation is used to measure the flow for non-standard density:

$$ACFM = C1 \times A \times \sqrt{(\Delta P/\rho)}$$

where: A = Inlet funnel throat area (square feet) - from Table 34

$\Delta P$  = The differential in static pressure from the piezometer ring and the inlet pressure tap (inches w.g.)

$\rho$  = Air density (pounds mass/cubic foot)

C1 = Value from Table 33

### Standard Density Method

The equation can be simplified by assuming standard density and assuming funnel dimensions match the drawing dimensions. Table 33 shows the factor (K) for each fan size and type. The equation then becomes the following:

For standard air ( $\rho = 0.075 \text{ lb/ft}^3$ ):

$$ACFM = K \times \sqrt{(\Delta P)}$$

where: K = factor from Table 34

$\Delta P$  = The differential in static pressure from the piezometer ring and the front pressure tap (inches w.g.)

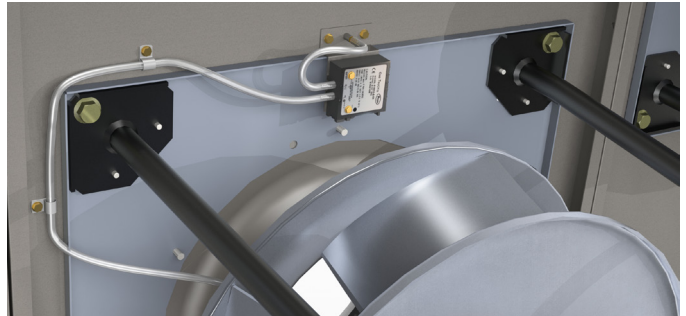
**Table 33: ECM Factors for Free and Ducted Inlet — Non-Standard Density Method**

ECM Size	C1 Free Inlet	C1 Ducted Inlet
355	774.47	774.47
450	783.31	783.31
560	658.54	658.54
630	666.68	666.68
355D	802.05	802.05
450D	783.31	783.31

**Table 34: ECM Factors for Free and Ducted Inlet — Standard Density Method**

ECM Size	Free Inlet K	Ducted Inlet K	Area A
355	774.47	774.47	0.485
450	783.31	783.31	0.778
560	658.54	658.54	1.341
630	666.68	666.68	1.667
355D	1459.58	1459.58	0.498
450D	2283.43	2283.43	0.798

**Figure 70: Piezometer Transducer**



## Fan Vibration Levels

Each unit as shipped is trim balanced to operate smoothly. To provide satisfactory operation after shipping and installation, use the accepted industry guidelines for field balancing fans. See Table 35.

**Table 35: Vibration Levels**

Fan speed (rpm)	Vibration
800 or less	5 mils maximum displacement
801 or greater	0.20 in/sec. maximum velocity

Note: Excessive vibration from any cause contributes to premature fan and motor bearing failure. Monitor overall vibration levels every six months of operation. An increase in levels is an indication of potential trouble.

## Vibration Causes

1. Wheel imbalance
  - a. Dirt or debris on wheel blades
  - b. Loose set screws in wheel hub or bearing-to-shaft
  - c. Wheel distorted from overspeed
2. Bent shaft
3. Drive faulty
  - a. Variable pitch sheaves—Axial and radial runout of flanges; uneven groove spacing; out of balance. Also similar faults in driven sheave.
  - b. Bad V-belts; lumpy, or mismatched; belt tension too tight or too loose.
4. Bad bearings, loose bearing hold-down bolts
5. Motor imbalance
6. Fan section not supported evenly on foundation

## Fan Operating Limits

Do not exceed the operating limits in the following tables. A fan wheel operated beyond the rpm and temperature limits shown can suffer permanent distortion or fracture. The resulting unbalance can cause severe unit vibration.

**Table 36: Physical Data—Forward Curved and Airfoil Fans, Unit Sizes 107 to 169**

Forward curved fans – in. (mm)										
Diameter Class I	20 (508)	22.38 (568)	25 (635)	27.62 (702)	30.25 (768)	33 (838)	36 (914)	—	—	—
Maximum rpm	1010	930	790	690	650	600	560	—	—	—
Shaft and bearing diameter	1.438 (37)	1.438 (37)	1.688 (43)	1.688 (43)	1.688 (43)	2.188 (56)	2.188 (56)	—	—	—
Outlet area – sq ft (sq m)	4.2 (0.39)	5.1 (0.474)	6.71 (0.623)	8.07 (0.75)	9.3 (0.864)	12.05 (1.119)	12.8 (1.189)	—	—	—
Diameter Class II	20 (508)	22.38 (568)	25 (635)	27.62 (702)	30.25 (768)	33 (838)	36 (914)	—	—	—
Maximum rpm	1281	1178	1011	910	835	763	715	—	—	—
Shaft and bearing diameter	1.688 (43)	2.188 (56)	2.438 (62)	2.438 (62)	2.688 (68)	2.688 (68)	2.688 (68)	—	—	—
Outlet area – sq ft (sq m)	4.2 (0.39)	5.1 (0.474)	6.71 (0.623)	8.07 (0.750)	9.3 (0.864)	12.05 (1.119)	12.8 (1.189)	—	—	—
Airfoil fans – in. (mm)										
Diameter Class I	20 (508)	22.25 (565)	24.5 (622)	27 (686)	30 (762)	33 (838)	36.5 (927)	40.25 (1022)	44.5 (1130)	49.0 (1244)
Maximum rpm	2077	1875	1691	1479	1328	1209	1073	972	884	805
Shaft and bearing diameter	1.688 (43)	1.938 (49)	2.188 (56)	2.188 (56)	2.438 (62)	2.438 (62)	2.438 (62)	2.938 (75)	3.188 (81)	3.438 (87)
Outlet area – sq ft (sq m)	4.14 (0.385)	5.12 (0.476)	6.21 (0.577)	7.54 (0.7)	9.31 (0.865)	11.27 (1.047)	13.79 (1.281)	16.77 (1.558)	20.5 (1.905)	24.9 (2.313)
Diameter Class II	20 (508)	22.25 (565)	24.5 (622)	27 (686)	30 (762)	33 (838)	36.5 (927)	40.25 (1022)	44.5 (1130)	49.0 (1244)
Maximum rpm	2703	2413	2199	1928	1730	1579	1401	1264	1146	1040
Shaft and bearing diameter	2.188 (56)	2.188 (56)	2.438 (62)	2.438 (62)	2.688 (68)	2.938 (75)	2.938 (75)	3.438 (87)	3.938 (100)	3.938 (100)
Outlet area – sq ft (sq m)	4.14 (0.385)	5.12 (0.476)	6.21 (0.577)	7.54 (0.7)	9.31 (0.865)	11.27 (1.047)	13.79 (1.281)	16.77 (1.558)	20.5 (1.905)	24.9 (2.313)
Diameter Class III	—	—	—	—	—	—	36.5 (927)	40.25 (1022)	44.5 (1130)	49.0 (1244)
Maximum rpm	—	—	—	—	—	—	1758	1586	1421	1308
Shaft and bearing diameter	—	—	—	—	—	—	3.438 (87)	3.438 (87)	3.438 (87)	3.938 (100)
Outlet area – sq ft (sq m)	—	—	—	—	—	—	13.8 (1.281)	16.8 (1.558)	20.5 (1.905)	24.9 (2.313)

**Table 37: Operating Limits—Belt-Drive Plenum Fans**

Size	18	20	22	24	27	30	33	36	40	44	49	54	60
Max RPM Class II	2930	2674	2403	2183	1860	1783	1620	1465	1329	1202	1091	986	891
Max RPM Class III	3735	3409	3065	2780	2423	2182	1984	1759	1598	1447	1314	1178	1071

**Table 38: Operating Limits—Direct-Drive Plenum Fans**

Size	18	20	22	24	27	30	33	36	40	44	49	54	60
Max RPM Class II	3650	2674	2403	2183	1981	1783	1620	1465	1329	1202	—	—	—
Max RPM Class III	3735	3409	3065	2780	2423	2182	1984	1759	1598	1447	1314	1178	1071

## Gas Phase Filtration Technology

Please refer to the manual provided with unit for installation, operation, and maintenance related to gas phase filtration technology, otherwise known as sorbent cleaners.

**NOTE:** If the sorbent cleaner exhaust air is ducted out of the building, it is the responsibility of the field to include booster fans in the ductwork to properly exhaust the air during the regeneration cycle.

**NOTE:** Provided exhaust hood(s) can be discarded for indoor units. Properly connect ductwork in the field to the exhaust opening(s) on the sorbent cleaner section.

**NOTE:** In instances where more than one module is being applied, there is one main control box for line voltage and control voltage connections. This box will contain the controller and landing terminals for the control connection wires from the building. If more than one module is being applied, section splits may be present. If so, factory supplied wires will need to be routed into the provided junction box on each sorbent cleaner module. Conduit routing will be provided for these connections.

## Electric and Gas Heat

### Electric Heat

Vision indoor units are available with up to 10-step heat output. Vision units with electric heat are designed for indoor non-residential installations only. The electric heat design consists of a open coil heating elements, Step or SCR Vernier control, and all operational safeties. The safety switches include high-limit temperature switches and an airflow proving switch.

The high limit switch is an automatic reset switch. It opens the control circuit and shuts the heater down when the temperature reaches the high limit switch closes again allows the heater to run when the temperature gets below dead band. There is a second level of protection with an auxiliary high limit switch. This switch opens up and shuts the heater down when the temperature exceeds the set point. This switch requires a manual reset.

**NOTE:** It is not recommended to utilize the auxiliary electric heat as a reheat source for space control.

### Gas Furnace Heat

For installation and maintenance information related to gas furnace heat, refer to IM 1300.

### A2L Refrigerant Requirements

Daikin Applied units equipped with an A2L refrigerant (Optional DX Coil Component), requires means for mitigation in the unlikely event of a refrigerant leak. Units will therefore come equipped with an R32 or R454B Refrigerant Leak Detection System (RDS) and mitigation control relay with normally open contacts for mitigation activation. See [A2L Refrigerant Guidelines \(if applicable\) on page 47](#) and the leak mitigation control board manual for more details.

For applications where an electric or gas heater is used in conjunction with a DX coil, the mitigation process requires the heat source to be de-energized using the RDS. The follow installation requirements apply:

- Daikin Applied Air Handler is equipped with an A2L refrigerant has a factory installed RDS. Sensor is located in the drain pan and wired to the mitigation control panel.
- Units in a modulating hot gas reheat (MHGRH) configuration will have two sensors; one downstream of the DX coil and one downstream of the MHGRH coil.
- The factory installed RDS in the Daikin Applied equipment may not be field modified.
- The RDS relay outputs (dry contacts) are field wired to the electric or gas heater control panel to de-energize the heater element when a refrigerant leak is detected. See DX coil mitigation control panel and electric heater control panel for schematics.

Figure 71: RDS Connection Point - Electric Heat Example

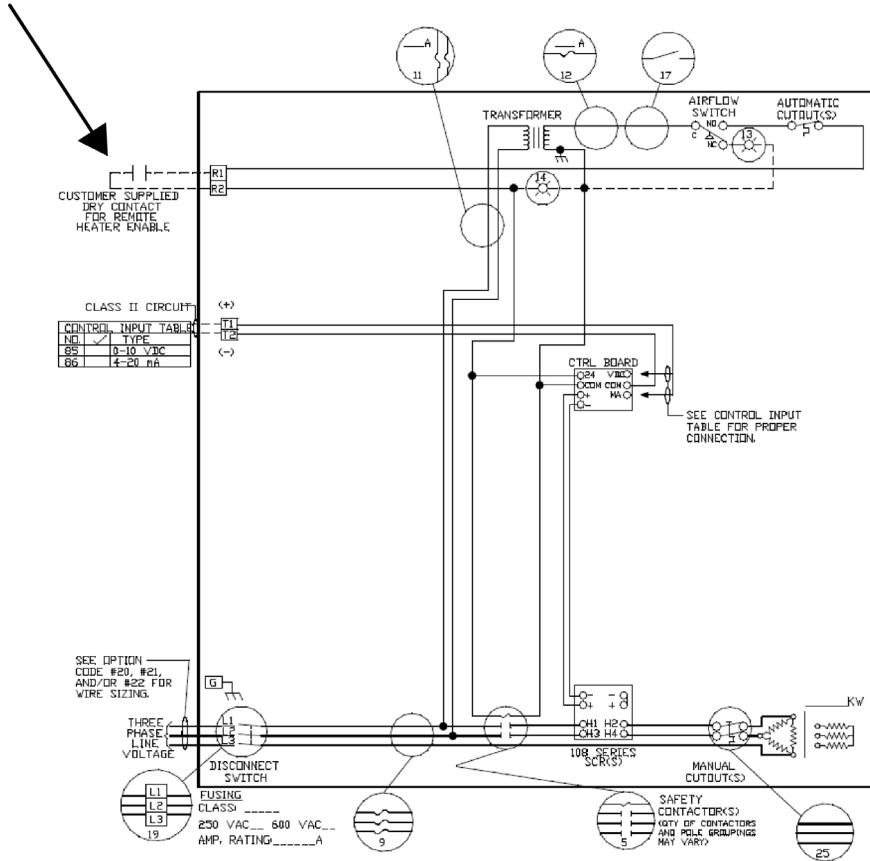
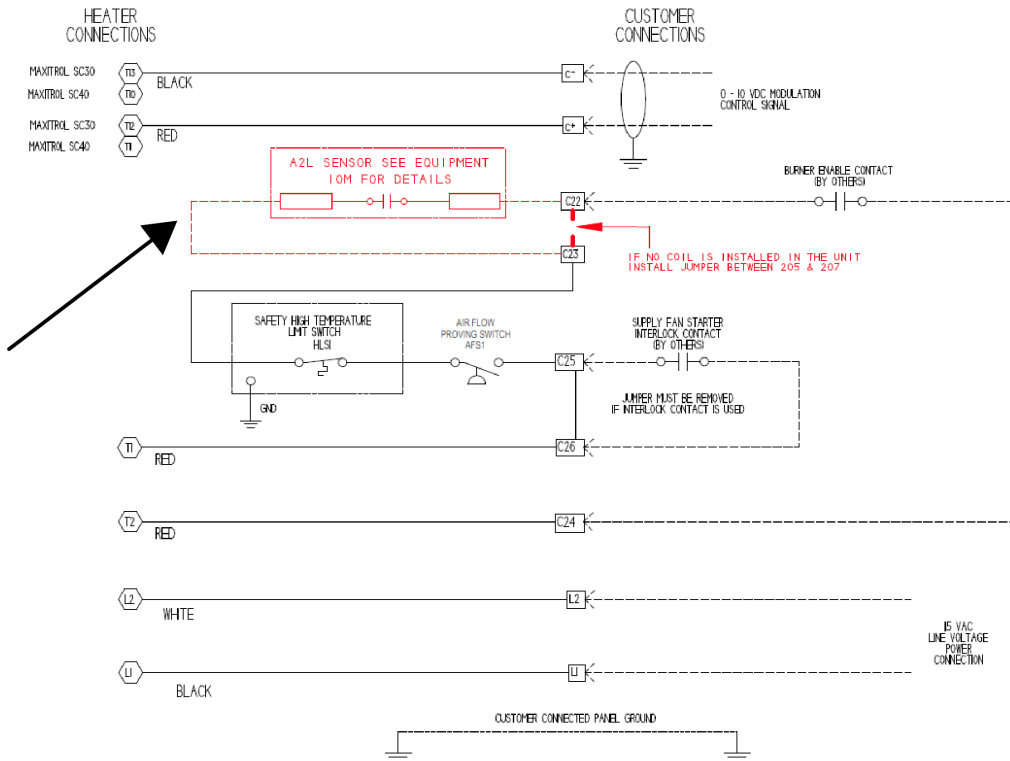






Figure 72: RDS Connection Point - Gas Heat Example




## A2L Refrigerant Guidelines (if applicable)

 <b>WARNING</b>	
 <b>A2L</b>	<p>This unit contains either R-32 or R-454b. Both are class A2L refrigerants that are flammable. This unit should only be installed, serviced, repaired, and disposed of by qualified personnel licensed or certified in their jurisdiction to work with the specific A2L refrigerant. Installation and maintenance must be done in accordance with this manual. Improper handling of this equipment can cause personal injury or equipment damage.</p>
<p>Be aware that R-32 and R454b refrigerant may not contain an odor. Place in a well ventilated area to prevent accumulation of refrigerant. Excessive refrigerant leaks, in the event of an accident in a closed ambient space, can lead to oxygen deficiency.</p> <p>Do not pierce or burn this unit.</p> <p>Never use an open flame during service or repair. Never store in a room with continuously operating ignition sources (for example: open flames, an operating gas appliance, or and operating electric heater), where there is ignitable dust suspension in the air, or where volatile flammables such as thinner or gasoline are handled.</p> <p>Vision units may be shipped as partial units and should only be connected to appliances that are suitable for the air handling unit's designated refrigerant.</p> <p>Only use pipes, nuts, and tools intended for exclusive use with the unit's designated A2L refrigerant in compliance with national codes (ASHRAE15 or IRC).</p> <p>Do not mix air or gas other than the unit's designated A2L refrigerant in the refrigerant system. If air enters the refrigerant system, an excessively high pressure results, which may cause equipment damage or injury.</p> <p>Do not use means to accelerate the defrosting process or to clean, other than those recommended by the manufacturer.</p>	

 <b>DANGER</b>	
<p><b>LOCKOUT/TAGOUT</b> all power sources prior to servicing the unit or opening any panels or doors. This Appliance is equipped with a Refrigerant Leak Detection system and the system components such as supply fans may begin operation unexpectedly and without warning.</p>	

 <b>WARNING</b>	
<p>Unit must be powered at all times, except when servicing. The appliance is designed with leakage mitigation, which requires continuous airflow in the event a refrigerant leak is detected. This is required to ensure dilution and prevent stagnation of any leaked refrigerant. Always ensure the supply fans are able to operate freely. Always maintain proper airflow and do not allow filters, air inlets, or air outlets to become blocked.</p>	

 <b>WARNING</b>	
<p>In the unlikely event that a refrigerant leak occurs, all dampers must be driven to remain fully open to provide ventilation.</p>	

 <b>WARNING</b>	
<p>Units using A2L refrigerants connected to one or more rooms must be ducted directly to the space. Open areas, such as false ceilings cannot be used as a return air duct.</p>	

### Safety Considerations

This unit is equipped with an A2L (R32 or R454b) refrigerant and a Refrigerant Leak Detection and Mitigation system. In the unlikely event of a refrigerant leak, the unit must be instructed to take mitigating actions such as activation of diluting airflow and/or disabling certain unit functions. For full details on the mitigation modes and sequence of operation please refer to the literature for the A2L mitigation control board. For connection to customer control systems or a Building Management System a field connection is provided with the A2L controls. Please refer to the unit specific electrical schematic for the connection details.

Maintaining and servicing A2L refrigerants should only be performed as recommended by this manual and by personnel licensed or certified in their jurisdiction to handle A2L refrigerants under a controlled procedure. Dismantling the unit and treatment of the refrigerant, oil, and additional parts must be done in accordance with the relevant local, state, and national regulations.

Only use tools meant for use on the unit's designated A2L refrigerant, such as a gauge manifold, charge hose, gas leak detector, reverse flow check valve, refrigerant charge base, vacuum gauge, or refrigerant recovery equipment.

### Field Installation Considerations

All Field installed or modified refrigerant containing pipe-work including piping material, pipe routing, and installation shall include protection from physical damage in operation and service, and be in compliance with national and local codes and standards, such as ASHRAE 15, ASHRAE 15.2, IAPMO Uniform Mechanical Code, ICC International Mechanical Code, or CSA B52. All field joints shall be accessible for inspection prior to being covered or enclosed.

After completion of any field installed piping for split systems the pipework shall be pressure tested with an inert gas and vacuum tested prior to being charged with refrigerant per the procedure below.

The minimum test pressure for the low side of the system shall be the low side design pressure and the minimum test pressure for the high side of the system shall be the high side design pressure, unless the high side of the system, cannot be isolated from the low side of the system in which case the entire system shall be pressure tested to the low side design pressure.

**NOTE:** For information on field control wiring requirements when electric or gas heat ignition sources are present, consult [See A2L Refrigerant Requirements on page 45](#).

## Minimum Room Area

### WARNING

Failure to maintain the required Minimum Room Area for leaked refrigerant dilution may result in property damage, serious personal injury, or death.

In the unlikely event of a refrigerant leak, the leak detection system must activate the supply fans to a preset speed that corresponds to an airflow that is always greater than the minimum required airflow rate. This airflow is required to dilute any leaked refrigerant and prevent stagnation. The actual unit airflow may be much higher depending on configuration. The minimum airflow rate is based on circuit charge quantity and is detailed in [Figure 75 on page 51](#) and [Figure 76 on page 52](#).

This unit contains an A2L refrigerant (R-32 or R-454b). The served indoor space must be larger than or equal to the Minimum Room Area as shown starting on [page 49](#). In the unlikely event of a refrigerant leak this room area must meet this requirement to ensure dilution and prevent stagnation of any leaked refrigerant.

The Refrigerant Charge of each unit should be determined and used to confirm the Minimum Room Area prior to installation. For guidance on refrigerant charge calculation, see “[Minimum Room Area Calculation \(A2L Refrigerants\)](#)” on [page 19](#).

When the appliance is connected to an unventilated space the following rules shall apply to determine if connected spaces can be used in the Minimum Room Area calculation. The room area shall be defined as the room area enclosed by the projection to the floor of the walls, partitions and doors of the space in which the unit serves. Spaces connected by only drop ceilings, ductwork, or similar connections shall not be considered a single space. Rooms on the same floor and connected by an open passageway between the spaces can be considered a single room when determining compliance to Minimum Room Area, if the passageway complies with all of the following:

- It is a permanent opening.
- It extends to the floor.
- It is intended for people to walk through.

The area of the adjacent rooms, on the same floor, connected by a permanent opening in the walls and/or doors between occupied spaces, including gaps between the wall and the floor, can be considered a single room when determining compliance to the Minimum Room Area, provided all of the following are met:

- The minimum opening area connecting the spaces/rooms shall not be less than 0.0123 m<sup>2</sup>.
- The area of any openings above 300 mm from the floor shall not be considered part of the minimum opening area.
- At least 50 % of the minimum opening area shall be below 200 mm from the floor.
- Openings are permanent openings which cannot be closed.
- For openings extending to the floor the height shall not be less than 20 mm above the surface of the floor covering.
- A second higher opening shall be provided. The total size of the second opening shall not be less than 50% of the minimum opening area and shall be at least 1.5 m above the floor.

**NOTE:** The requirement for the second opening can be met by drop ceilings, ventilation ducts, or similar arrangements that provide an airflow path between the connected rooms.

## Altitude Considerations for Minimum Room Area

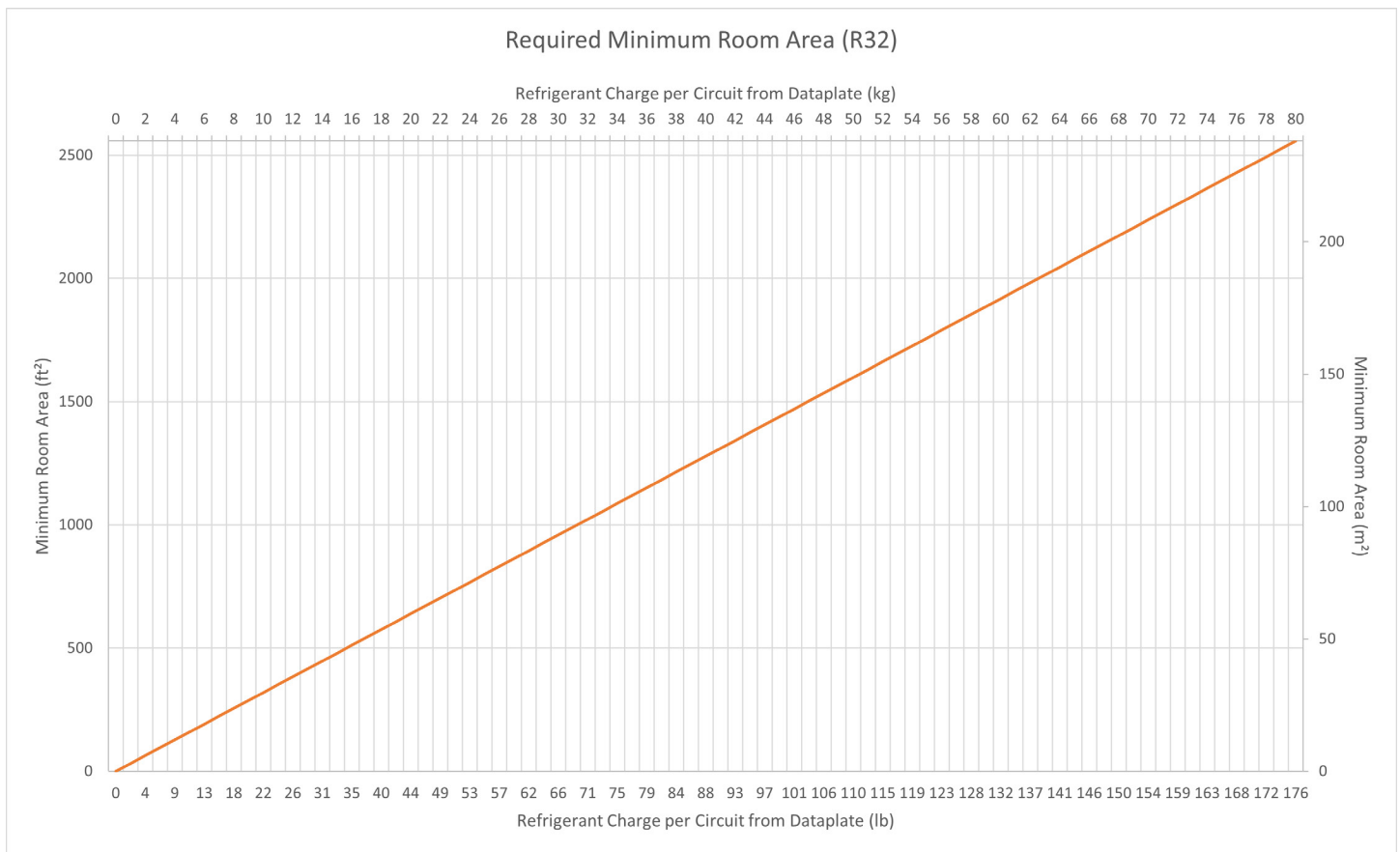
When the unit is installed at altitude above sea level the minimum room area must be adjusted by the multiplier shown in [Table 39 on page 49](#). This will increase the required minimum room area of the served space.

If the actual room area served by the appliance is not large enough to meet the Minimum Room Area additional measures such as mechanical ventilation of the space may need to be employed. Please contact Daikin Applied for additional information.

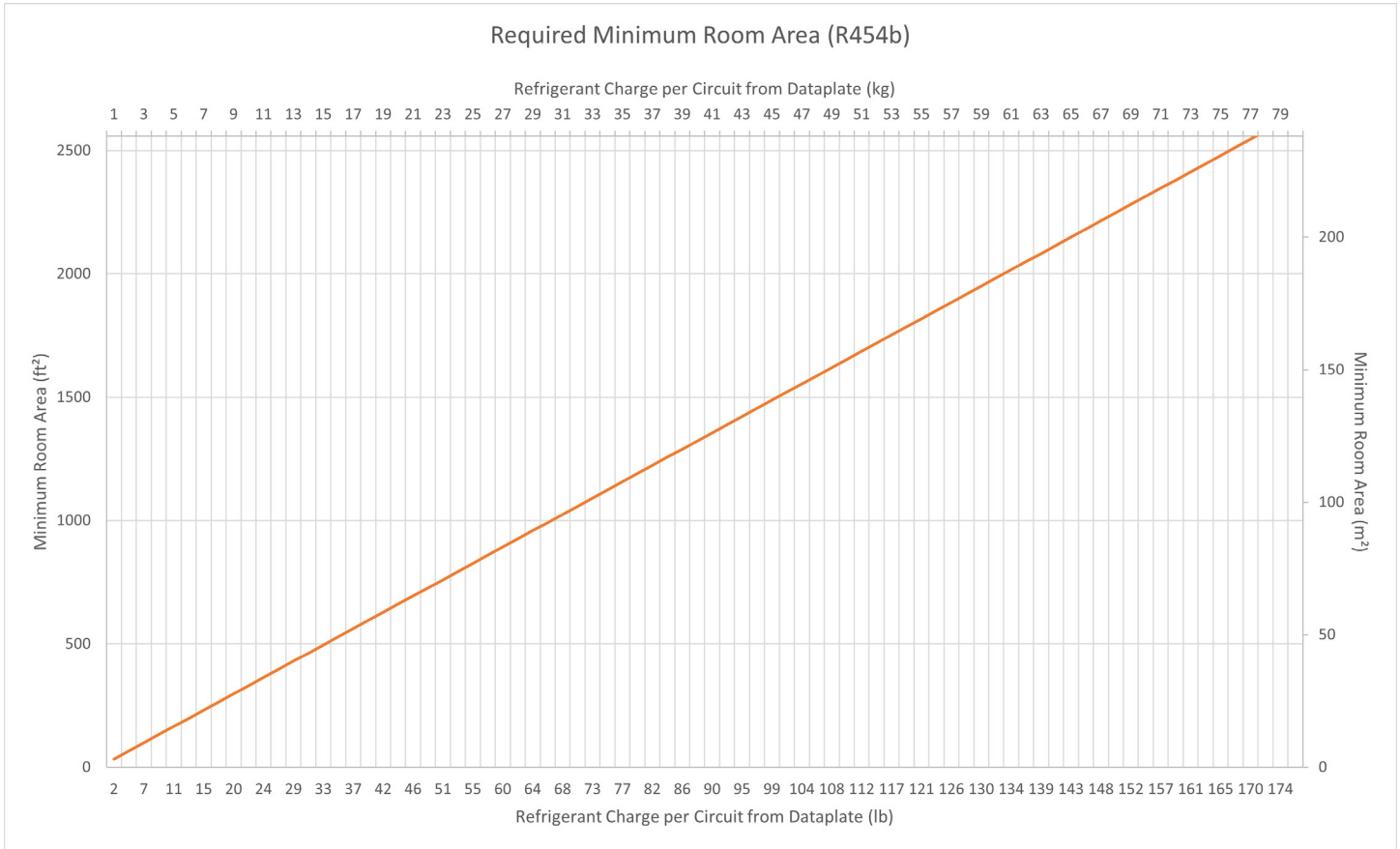
**Table 39: Minimum Room Area Multipliers by Altitude**

Altitude (Meters)	Minimum Room Area Multiplier
0	1
305	1.047
500	1.078
750	1.117
1000	1.156
1250	1.195
1500	1.234
1750	1.273
2000	1.312
2250	1.351
2500	1.39
2750	1.429
3000	1.468
3250	1.507
3500	1.546

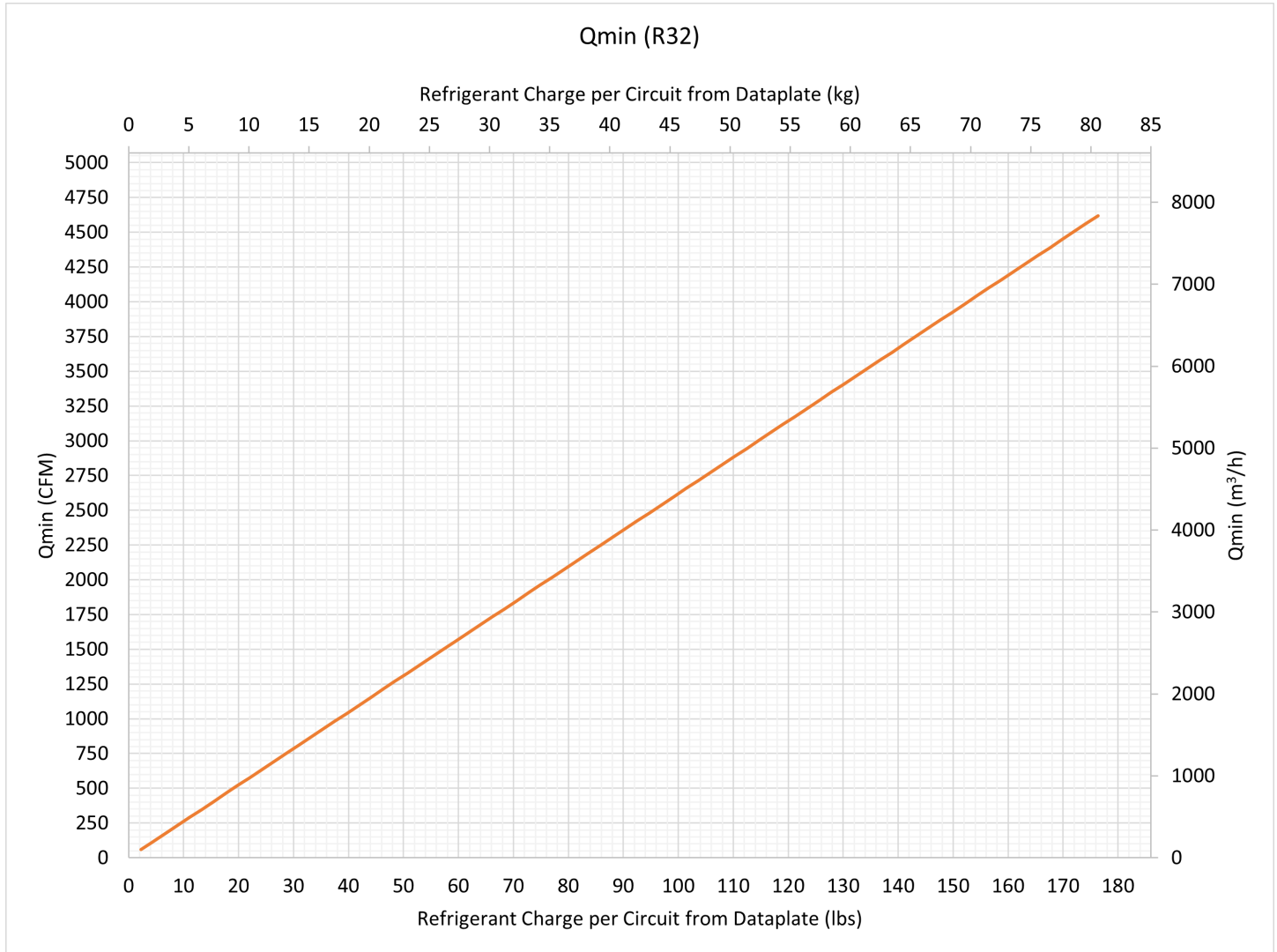
**Figure 73: R32 Refrigerant - Required Minimum Room Area Chart**



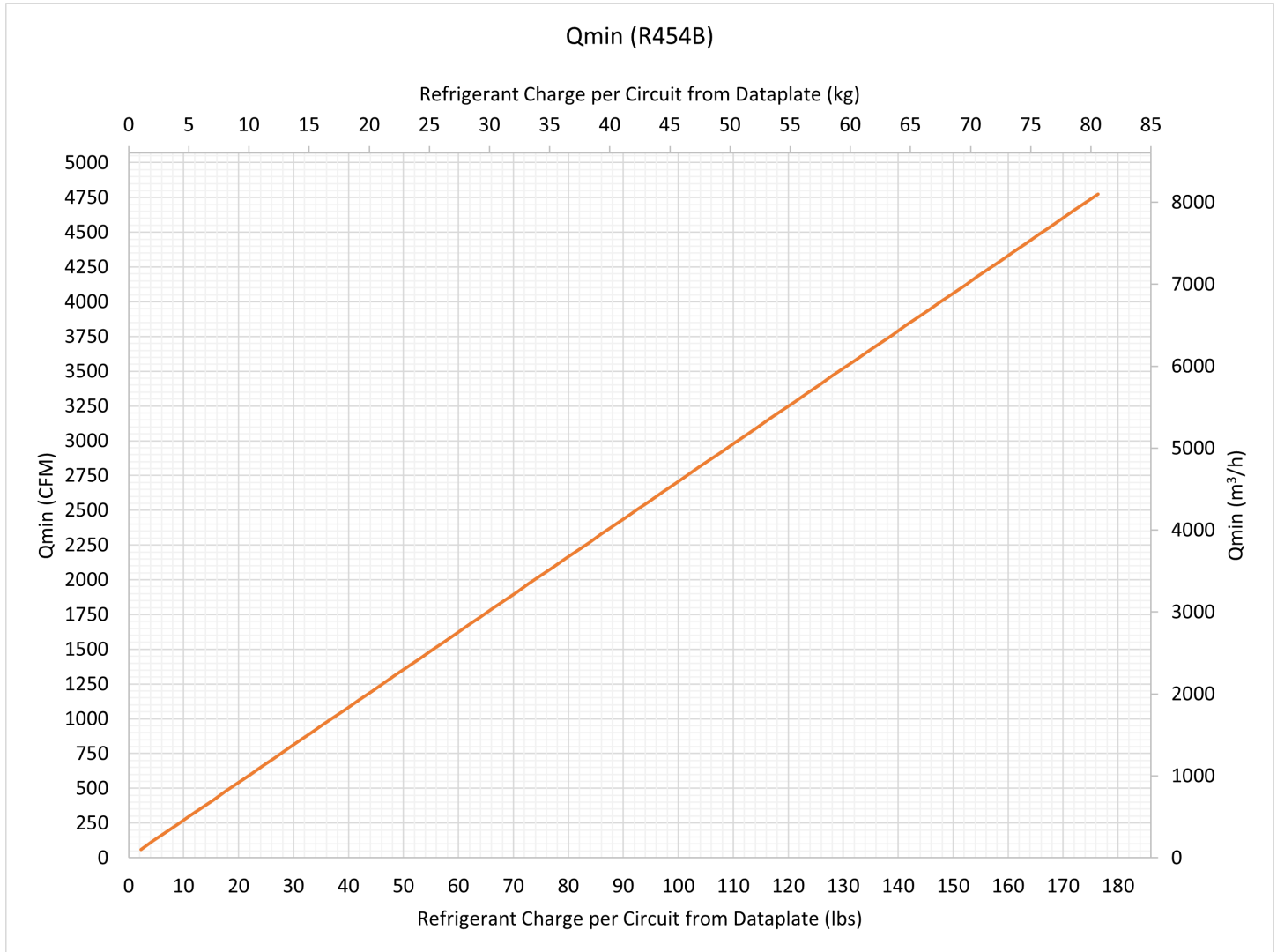
**Figure 74: R454b Refrigerant - Required Minimum Room Area Chart**



**Figure 75: R32 Refrigerant - Minimum Circulation of Airflow (Qmin)**



**Figure 76: R454b Refrigerant - Minimum Circulation of Airflow (Qmin)**



## Leak Mitigation System and Sensors

For Additional Instructions on how to operate the Leak Mitigation System, refer to IM 1365.

### WARNING

This equipment is equipped with a Refrigerant Leak Detection System. Only components and Refrigerant Detection Sensors specified by Daikin Applied may be used for replacement and maintenance.

### WARNING

Always ensure the Refrigerant Detection Sensors installed in the equipment are free of debris and the inlet is not blocked. If replacing a Refrigerant Detection Sensor always install in the identical orientation as the original sensor.

**Figure 77: Sample Refrigerant Detection Sensor**



**NOTE:** Identify the sensor inlet marked “Do Not Block Inlet”.

### WARNING

Auxiliary devices which may be a Potential Ignition Source shall not be installed in the duct work. Examples of such Potential Ignition Sources are hot surfaces with a temperature exceeding 1292°F (700°C) and electric switching devices.

### WARNING

The unit must be stored and/or located to prevent mechanical damage of the refrigeration system. Do not store the unit near sources of open flame, electrical switching devices, or hot surfaces above 1292°F (700°C). If the unit is stored indoors the storage area should be larger than the Minimum Room Area specified in this manual. The storage space should be well ventilated and not allow for the stagnation of leaked refrigerant. Failure to do so may result in a fire or explosion hazard.

### WARNING

Only auxiliary devices approved by Daikin Applied or declared suitable for installation with the unit's designated A2L refrigerant shall be installed in the connecting ductwork.

## Performing Service

### **Remove Ignition Sources**

Always perform a safety check of the area to ensure the risk of ignition is minimized before servicing the unit.

### **Personnel Awareness**

Inform maintenance staff and others working in the local area of the nature of work being carried out. Only personnel attending to the refrigerant system should be present.

### **Check for Presence of Airborne Refrigerant**

Check the area with an appropriate refrigerant detector prior to and during work to ensure all personnel are aware of potentially toxic or flammable gases in the air. Ensure that the leak detection equipment being used is suitable for use with all applicable refrigerants; i.e., non-sparking, adequately sealed or intrinsically safe.

### **Presence of fire extinguisher**

If any hot work is to be conducted on the refrigerating equipment or any associated parts, appropriate fire extinguishing equipment should be available to hand. Have a dry powder or CO2 fire extinguisher adjacent to the charging area.

### **No Ignition Sources**

No person carrying out work in relation to a REFRIGERATING SYSTEM which involves exposing any pipe work shall use any sources of ignition in such a manner that it may lead to the risk of fire or explosion. All possible ignition sources, including cigarette smoking, should be kept sufficiently far away from the site of installation, repairing, removing and disposal, during which refrigerant can possibly be released to the surrounding space. Prior to work taking place, the area around the equipment is to be surveyed to make sure that there are no flammable hazards or ignition risks. “No Smoking” signs shall be displayed.

### **Ventilated area**

Ensure that the area is in the open or that it is adequately ventilated before breaking into the system or conducting any hot work. A degree of ventilation shall continue during the period that the work is carried out.

### **Checks to the refrigerating equipment**

Where electrical components are being changed, they shall be fit for the purpose and to the correct specification. At all times the manufacturer's maintenance and service guidelines shall be followed. If in doubt, consult the manufacturer's technical department for assistance.

The following checks shall be applied to installations using FLAMMABLE REFRIGERANTS:

- The actual REFRIGERANT CHARGE is in accordance with the room size within which the refrigerant containing parts are installed.
- The ventilation machinery and outlets are operating adequately and are not obstructed.

- If an indirect refrigerating circuit is being used, the secondary circuit shall be checked for the presence of refrigerant.
- Marking to the equipment continues to be visible and legible. Markings that are illegible shall be corrected.
- Refrigerating pipe or components are installed in a position where they are unlikely to be exposed to any substance which may corrode refrigerant containing components, unless the components are constructed of materials which are inherently resistant to being corroded or are suitably protected against being so corroded.

### **Checks to electrical devices**

Repair and maintenance to electrical components shall include initial safety checks and component inspection procedures. If a fault exists that could compromise safety, then no electrical supply shall be connected to the circuit until it is satisfactorily dealt with. If the fault cannot be corrected immediately but it is necessary to continue operation, an adequate temporary solution shall be used. This shall be reported to the owner of the equipment so all parties are advised.

Initial safety checks shall include:

- that capacitors are discharged: this shall be done in a safe manner to avoid possibility of sparking;
- that no live electrical components and wiring are exposed while charging, recovering or purging the system;
- that there is continuity of earth bonding.

### **Repairs to sealed components**

Sealed electrical components shall be replaced.

### **Repair to intrinsically safe components**

Intrinsically safe components must be replaced.

### **Cabling**

- Check that cabling will not be subject to wear, corrosion, excessive pressure, vibration, sharp edges or any other adverse environmental effects. The check shall also take into account the effects of aging or continual vibration from sources such as compressors or fans.

### **Detection of flammable refrigerants**

Under no circumstances shall potential sources of ignition be used in the searching for or detection of refrigerant leaks. A halide torch (or any other detector using a naked flame) shall not be used.

The following leak detection methods are deemed acceptable for all refrigerant systems:

- Electronic leak detectors may be used to detect refrigerant leaks but, in the case of FLAMMABLE REFRIGERANTS, the sensitivity may not be adequate, or may need re-calibration. (Detection equipment shall be calibrated in a refrigerant-free area.) Ensure that the detector is not a potential source of ignition and is suitable for the refrigerant used. Leak detection equipment shall be set at a percentage of the LFL of the refrigerant and shall be

calibrated to the refrigerant employed, and the appropriate percentage of gas (25 % maximum) is confirmed.

- Leak detection fluids are also suitable for use with most refrigerants but the use of detergents containing chlorine shall be avoided as the chlorine may react with the refrigerant and corrode the copper pipe-work.

**NOTE:** Examples of leak detection fluids are:

- bubble method; or
- fluorescent method agents.

If a leak is suspected, all naked flames shall be removed/ extinguished.

If a leakage of refrigerant is found which requires brazing, all of the refrigerant shall be recovered from the system, or isolated (by means of shut off valves) in a part of the system remote from the leak. Removal of refrigerant shall be according to instructions above.

### **Removal and evacuation**

- When breaking into the refrigerant circuit to make repairs, or for any other purpose, conventional procedures shall be used. However, for flammable refrigerants it is important that best practice be followed, since flammability is a consideration.
- The following procedure shall be adhered to:
  - a. safely remove refrigerant following local and national regulations
  - b. purge the circuit with inert gas
  - c. evacuate
  - d. purge with inert gas
  - e. open the circuit by cutting or brazing
- The refrigerant charge shall be recovered into the correct recovery cylinders. For appliances containing flammable refrigerants, the system shall be purged with oxygen-free nitrogen to render the appliance safe for flammable refrigerants. This process might need to be repeated several times.
- Compressed air or oxygen shall not be used for purging refrigerant systems.
- For appliances containing flammable refrigerants, refrigerants purging shall be achieved by breaking the vacuum in the system with oxygen-free nitrogen and continuing to fill until the working pressure is achieved, then venting to atmosphere, and finally pulling down to a vacuum.
- When the final oxygen-free nitrogen charge is used, the system shall be vented down to atmospheric pressure to enable work to take place.
- Ensure that the outlet for the vacuum pump is not close to any potential ignition sources and that ventilation is available.

## Charging procedures

### ***In addition to conventional charging procedures, the following requirements shall be followed.***

- Ensure that contamination of different refrigerants does not occur when using charging equipment.
- Hoses or lines shall be as short as possible to minimise the amount of refrigerant contained in them.
- Cylinders shall be kept in an appropriate position according to the instructions.
- Ensure that the REFRIGERATING SYSTEM is earthed prior to charging the system with refrigerant.
- Label the system when charging is complete (if not already).
- Extreme care shall be taken not to overfill the REFRIGERATING SYSTEM.
- Prior to recharging the system, it shall be pressure-tested with the appropriate purging gas. The system shall be leak-tested on completion of charging but prior to commissioning. A follow up leak test shall be carried out prior to leaving the site.

## Decommissioning

***Before carrying out this procedure, it is essential that the technician is completely familiar with the equipment and all its detail. It is recommended good practice that all refrigerants are recovered safely.***

***Prior to the task being carried out, an oil and refrigerant sample shall be taken in case analysis is required prior to re-use of recovered refrigerant.***

***It is essential that electrical power is available before the task is commenced.***

- Become familiar with the equipment and its operation.
- Isolate system electrically.
- Before attempting the procedure, ensure that mechanical handling equipment is available, if required, for handling refrigerant cylinders; all personal protective equipment is available and being used correctly; the recovery process is supervised at all times by a competent person; recovery equipment and cylinders conform to the appropriate standards.
- Pump down refrigerant system, if possible.
- If a vacuum is not possible, make a manifold so that refrigerant can be removed from various parts of the system.
- Make sure that cylinder is situated on the scales before recovery takes place.
- Start the recovery machine and operate in accordance with instructions.
- Do not overfill cylinders (no more than 80 % volume liquid charge).

- Do not exceed the maximum working pressure of the cylinder, even temporarily.
- When the cylinders have been filled correctly and the process completed, make sure that the cylinders and the equipment are removed from site promptly and all isolation valves on the equipment are closed off.
- Recovered refrigerant shall not be charged into another REFRIGERATING SYSTEM unless it has been cleaned and checked.

## Labeling

***Equipment shall be labeled stating that it has been de-commissioned and emptied of refrigerant. The label shall be dated and signed. For appliances containing FLAMMABLE REFRIGERANTS, ensure that there are labels on the equipment stating the equipment contains FLAMMABLE REFRIGERANT.***

## Recovery

- When removing refrigerant from a system, either for servicing or decommissioning, the refrigerant must be removed safely.
- When transferring refrigerant into cylinders, ensure that only appropriate refrigerant recovery cylinders are employed. Ensure that the correct number of cylinders for holding the total system charge is available. All cylinders to be used are designated for the recovered refrigerant and labeled for that refrigerant (i.e., special cylinders for the recovery of refrigerant). Cylinders shall be complete with pressure-relief valve and associated shut-off valves in good working order. Empty recovery cylinders are evacuated and, if possible, cooled before recovery occurs.
- The recovery equipment shall be in good working order with a set of instructions concerning the equipment that is at hand and shall be suitable for the recovery of all appropriate refrigerants including, when applicable, FLAMMABLE REFRIGERANTS. In addition, a set of calibrated weighing scales shall be available and in good working order. Hoses shall be complete with leak-free disconnect couplings and in good condition. Before using the recovery machine, check that it is in satisfactory working order, has been properly maintained and that any associated electrical components are sealed to prevent ignition in the event of a refrigerant release. Consult manufacturer if in doubt.
- The recovered refrigerant shall be returned to the refrigerant supplier in the correct recovery cylinder, and the relevant waste transfer note arranged. Do not mix refrigerants in recovery units and especially not in cylinders.

***If compressors or compressor oils are to be removed, ensure that they have been evacuated to an acceptable level to make certain that FLAMMABLE REFRIGERANT does not remain within the lubricant.***

**The evacuation process shall be carried out prior to returning the compressor to the suppliers. Only electric heating to the compressor body shall be employed to accelerate this process. When oil is drained from a system, it shall be carried out safely.**

## Lubrication

R-32 should only be used with manufacturer-approved oil, such as DAPHNE FW68DE. The HFC refrigerant components in R-32 will not be compatible with mineral oil or alkylbenzene lubricants. R-32 systems will be charged with the OEM recommended lubricant, ready for use with R-32.

R-454b should only be used with manufacturer-approved oil. Check with your condensing unit supplier to verify the acceptable oils to use with the refrigerant system.

## Leak Detection

NEVER use the following when attempting to detect A2L refrigerant leaks:

- A halide torch (or any other detector using a naked flame)
- Substances containing chlorine

## Pressure Testing and Refrigerant Evacuation

- Make sure that air or any matter other than A2L refrigerants do not enter the refrigeration cycle.
- If refrigerant gas leaks occur in an enclosed area, ventilate the space as soon as possible.
- A2L refrigerants should always be recovered and never released directly into the environment.
- Only use tools meant for use on the unit's designated A2L refrigerant (such as a gauge manifold, charging hose, or vacuum pump adapter).

## Commissioning

- Ensure proper connection of all piping and carry out a leak test before charging with refrigerant.
- Check safety equipment before putting into service.

## Decommissioning

ALWAYS remove refrigerant charge before decommissioning the unit.

- Ensure sufficient ventilation at the equipment location.
- Be aware that malfunction of the equipment may be caused by refrigerant loss and a refrigerant leak is possible.
- Discharge capacitors in a way that won't cause any spark.
- A2L refrigerants should always be recovered and never released directly into the environment. Take care that the drained refrigerant will not cause any danger. In doubt,

one person should guard the outlet. Take special care that drained refrigerant will not float back into the building.

## Recovery

### Recovery Cylinders

When transferring refrigerant into cylinders, ensure that only appropriate refrigerant recovery cylinders are employed. Ensure that the correct number of cylinders for holding the total system charge is available. All cylinders to be used should be designated for the recovered refrigerant and labeled for that refrigerant. Cylinders should be complete with a pressure-relief valve and associated shut-off valves in good working order. Empty recovery cylinders should be evacuated and, if possible, cooled before recovery occurs.

### Recovery Equipment

The recovery equipment should be in good working order with a set of instructions concerning the equipment that is at hand and shall be suitable for the recovery of all appropriate refrigerants including, when applicable, FLAMMABLE REFRIGERANTS. In addition, a set of calibrated weighing scales shall be available and in good working order. Hoses shall be complete with leak-free disconnect couplings and in good condition. Before using the recovery machine, check that it is in satisfactory working order, has been properly maintained and that any associated electrical components are sealed to prevent ignition in the event of a refrigerant release. Consult manufacturer if in doubt.

### Recovered Refrigerant

The recovered refrigerant should be returned to the refrigerant supplier in the correct recovery cylinder with the relevant waste transfer note assigned. Do not mix refrigerants in recovery units and especially not in cylinders.

### Compressor or Compressor Oils

If compressors or compressor oils are to be removed, ensure that they have been evacuated to an acceptable level to make certain that no refrigerant remains within the lubricant. The evacuation process should be carried out prior to returning compressors to the supplier(s). Only electric heating to the compressor body shall be employed to accelerate this process.

## Handling and Storage

### Precautions for Safe Handling

- Waste air is to be released into the atmosphere only via suitable separators. Open and handle receptacle with care.
- Keep ignition sources away.
- Do not smoke near the unit.
- Protect against electrostatic charges.

### Conditions for Safe Storage

- Requirements to be met by storerooms and receptacles:
  - Store only in unopened original receptacles
  - Store in a cool and dry location

- Further information about storage conditions:
  - Keep container tightly sealed
  - Store in cool, dry conditions in well sealed receptacle
  - Protect from heat and direct sunlight
- Maximum storage temperature:
  - 40°C

## Disposal

- Waste treatment method recommendation:
  - Must be specially treated adhering to official regulations.
  - Incineration in an adequate incinerator is recommended.
  - Uncleaned packaging disposal must be made according to official regulations.
- Ensure sufficient ventilation at the working place.
- Remove the refrigerant. A2L refrigerants should always be recovered and never released directly into the environment. Take care that the drained refrigerant will not cause any danger. In doubt, one person should guard the outlet. Take special care that drained refrigerant will not float back into the building.
- Evacuate the refrigerant circuit.
- Purge the refrigerant circuit with nitrogen for 5 min.
- Evacuate again.
- Cut out the compressor and drain the oil

## Competence of Personnel

There are specific procedures that must be followed for the installation, repair, maintenance, and decommissioning of equipment that uses A2L refrigerants.

Training for these procedures is carried out by national training organizations or manufacturers that are accredited to teach the relevant national competency standards that may be set in legislation. The achieved competence should be documented by a certificate.

## Information and Training

### *The training should include the substance of the following*

- Information about the explosion potential of flammable refrigerants to show that flammables may be dangerous when handled without care.
- Information about potential ignition sources, especially those that are not obvious, such as lighters, light switches, vacuum cleaners, electric heaters.
- Information about the different safety concepts:
  - Unventilated: Safety of the appliance does not depend on ventilation of the housing. Switching off the appliance or opening of the housing has no significant effect on safety. Nevertheless, it is possible that leaking refrigerant may accumulate inside the enclosure and flammable atmosphere will be released when the enclosure is opened.
  - Ventilated enclosure: Safety of the appliance depends

on ventilation of the housing. Switching off the appliance or opening of the enclosure has a significant effect on safety. Care should be taken to ensure sufficient ventilation before.

- Ventilated room: Safety of the appliance depends on the ventilation of the room. Switching off the appliance or opening of the housing has no significant effect on safety. The ventilation of the room shall not be switched off during repair procedures.
- Information about refrigerant detectors:
  - Principle of function, including influences on the operation.
  - Procedures, how to repair, check or replace a refrigerant detector or parts of it in a safe way.
  - Procedures, how to disable a refrigerant detector in case of repair work on the refrigerant carrying parts.
- Information about the concept of sealed components and sealed enclosures according to IEC 60079-15:2010.
- Information about the correct working procedures:
  - Commissioning
    - a. Ensure that the floor area is sufficient for the refrigerant charge or that the ventilation duct is assembled in a correct manner.
    - b. Connect the pipes and carry out a leak test before charging with refrigerant.
    - c. Check safety equipment before putting into service.
  - Maintenance
    - a. Portable equipment shall be repaired outside or in a workshop specially equipped for servicing units with flammable refrigerants.
    - b. Ensure sufficient ventilation at the repair place.
    - c. Be aware that malfunction of the equipment may be caused by refrigerant loss and a refrigerant leak is possible.
    - d. Discharge capacitors in a way that won't cause any spark. The standard procedure to short circuit the capacitor terminals usually creates sparks.
    - e. Reassemble sealed enclosures accurately. If seals are worn, replace them.
    - f. Check safety equipment before putting into service.
  - Repair
    - a. Portable equipment shall be repaired outside or in a workshop specially equipped for servicing units with flammable refrigerants.
    - b. Ensure sufficient ventilation at the repair place.
    - c. Be aware that malfunction of the equipment may be caused by refrigerant loss and a refrigerant leak is possible.
    - d. Discharge capacitors in a way that won't cause any spark.
    - e. When brazing is required, the following procedures shall be carried out in the right order:

- Removal of the refrigerant. A2L refrigerants should always be recovered and never released directly into the environment. Take care that the drained refrigerant will not cause any danger. In doubt, one person should guard the outlet. Take special care that drained refrigerant will not float back into the building.
- Evacuation the refrigerant circuit.
- Removal of parts to be replaced by cutting, not by flame.
- Purging of the braze point with nitrogen during the brazing procedure.
- Carrying out a leak test before charging with refrigerant.
  - a. Reassemble sealed enclosures accurately. If seals are worn, replace them.
  - b. Check safety equipment before putting into service.
- Decommissioning
  - a. The refrigerant charge must be removed before decommissioning.
  - b. Ensure sufficient ventilation at the equipment location.
  - c. Be aware that malfunction of the equipment may be caused by refrigerant loss and a refrigerant leak is possible.
  - d. Discharge capacitors in a way that won't cause any spark.
  - e. Remove the refrigerant. A2L refrigerants should always be recovered and never released directly into the environment. Take care that the drained refrigerant will not cause any danger. In doubt, one person should guard the outlet. Take special care that drained refrigerant will not float back into the building.
- Disposal
  - a. Ensure sufficient ventilation at the working place.
  - b. Remove the refrigerant. R-32 should always be recovered and never released directly into the environment. Take care that the drained refrigerant will not cause any danger. In doubt, one person should guard the outlet. Take special care that drained refrigerant will not float back into the building.

## Maintenance

- Equipment shall be repaired outside or in a workshop specially equipped for servicing units with A2L refrigerants.
- Ensure sufficient ventilation at the location where repairs are taking place.
- Be aware that malfunction of the equipment may be caused by refrigerant loss and a refrigerant leak is possible.
- Discharge capacitors in a way that won't cause sparks.
- When repairs are Reassemble sealed enclosures. If seals are worn, replace them.
- Check safety equipment before putting into service.

## Repair

- Portable equipment shall be repaired outside or in a workshop specially equipped for servicing units with FLAMMABLE REFRIGERANTS.
- Ensure sufficient ventilation at the repair place.
- Be aware that malfunction of the equipment may be caused by refrigerant loss and a refrigerant leak is possible.
- Discharge capacitors in a way that won't cause any spark.
- When brazing is required, the following procedures shall be carried out in the right order:
  - Remove the refrigerant. A2L refrigerants should always be recovered and never released directly into the environment. Take care that the drained refrigerant will not cause any danger. In doubt, one person should guard the outlet. Take special care that drained refrigerant will not float back into the building.
  - Evacuate the refrigerant circuit.
  - Remove parts to be replaced by cutting, not by flame.
  - Purge the braze point with nitrogen during the brazing procedure.
  - Carry out a leak test before charging with refrigerant.
- Reassemble sealed enclosures accurately. If seals are worn, replace them.
- Check safety equipment before putting into service.

## Recovery

### Recovery Cylinders

When transferring refrigerant into cylinders, ensure that only appropriate refrigerant recovery cylinders are employed. Ensure that the correct number of cylinders for holding the total system charge is available. All cylinders to be used should be designated for the recovered refrigerant and labeled for that refrigerant. Cylinders should be complete with a pressure-relief valve and associated shut-off valves in good working order. Empty recovery cylinders should be evacuated and, if possible, cooled before recovery occurs.

### Recovery Equipment

The recovery equipment should be in good working order with a set of instructions concerning the equipment that is at hand and shall be suitable for the recovery of all appropriate refrigerants including, when applicable, FLAMMABLE REFRIGERANTS. In addition, a set of calibrated weighing scales shall be available and in good working order. Hoses shall be complete with leak-free disconnect couplings and in good condition. Before using the recovery machine, check that it is in satisfactory working order, has been properly maintained and that any associated electrical components are sealed to prevent ignition in the event of a refrigerant release. Consult manufacturer if in doubt.

### Recovered Refrigerant

The recovered refrigerant should be returned to the refrigerant supplier in the correct recovery cylinder with the relevant waste transfer note assigned. Do not mix refrigerants in recovery units and especially not in cylinders.

## **Compressor or Compressor Oils**

If compressors or compressor oils are to be removed, ensure that they have been evacuated to an acceptable level to make certain that no refrigerant remains within the lubricant. The evacuation process should be carried out prior to returning compressors to the supplier(s). Only electric heating to the compressor body shall be employed to accelerate this process.

## **Handling and Storage**

### **Precautions for Safe Handling**

- Waste air is to be released into the atmosphere only via suitable separators. Open and handle receptacle with care.
- Keep ignition sources away.
- Do not smoke near the unit.
- Protect against electrostatic charges.

### **Conditions for Safe Storage**

- Requirements to be met by storerooms and receptacles:
  - Store only in unopened original receptacles
  - Store in a cool and dry location
- Further information about storage conditions:
  - Keep container tightly sealed
  - Store in cool, dry conditions in well sealed receptacle
  - Protect from heat and direct sunlight
- Maximum storage temperature:
  - 104°F (40°C)

## **Disposal**

- Waste treatment method recommendation:
  - Must be specially treated adhering to official regulations.
  - Incineration in an adequate incinerator is recommended.
  - Uncleaned packaging disposal must be made according to official regulations.
- Ensure sufficient ventilation at the working place.
- Remove the refrigerant. A2L refrigerants should always be recovered and never released directly into the environment. Take care that the drained refrigerant will not cause any danger. In doubt, one person should guard the outlet. Take special care that drained refrigerant will not float back into the building.
- Evacuate the refrigerant circuit.
- Purge the refrigerant circuit with nitrogen for 5 min.
- Evacuate again.
- Cut out the compressor and drain the oil.

# Service and Maintenance

## Periodic Service and Maintenance

1. Check all moving parts for wear every six months.
2. Check bearing collar, sheave, and wheel hub setscrews, sheave capscrews, and bearing hold-down bolts for tightness every six months.
3. Annually check and snug all electrical connections. Inspect for signs of water damage such as corrosion and repair if necessary. Check ground conductor and connection integrity and correct if needed.

## Bearing Lubrication



Bearing overheating potential. Can damage the equipment. Do not over-lubricate bearings. Use only a high grade mineral grease with a 200°F (93°C) safe operating temperature. See below for specific recommended lubricants.

### Motor Bearings

Supply and return fans—Supply and return fan motors should have grease added after every 2000 hours of operation. Using the following procedure, re-lubricate the bearings while the motor is warm, but not running. Use one of the greases shown in Table 40.

**NOTE:** Direct Drive Class II fans that are supplied with TECO motors have double shielded bearings on frame sizes 140T-280T. These bearings are pre-packed with a long life grease and are not re-greaseable. Larger frame size TECO motors are re-greaseable and follow the same lubrication recommendations as all other motors.

1. Remove and clean upper and lower grease plugs.
2. Insert a grease fitting into the upper hole and add clean grease (Table 40) with a low pressure gun.
3. Run the motor for five minutes before replacing the plugs.

**NOTE:** Specific greasing instructions are located on a tag attached to the motor. If special lubrication instructions are on the motor, they supersede all other instructions.

**Table 40: Recommended Lubricants and Amounts for Fan Motor Bearings**

Mfr. Grease	NEMA Size	Amount to Add (oz.)
Texaco, Polystar or Polyrex EM (Exxon Mobil) or Rykon Premium #2 or Penzoil Pen 2 Lube	56 to 140	0.08
	140	0.15
	180	0.19
	210	0.30
	250	0.47
	280	0.61
	320	0.76
	360	0.81
	400	1.25
	440	2.12

## Fan Shaft Bearings



For safety, stop rotating equipment. Add one half of the recommended amount shown in Table 42. Start bearing, and run for a few minutes. Stop bearing and add the second half of the recommended amount. A temperature rise, sometimes 30°F (1°C), after re-lubrication is normal. Bearing should operate at temperature less than 200°F (94°C) and should not exceed 225 (107°C) for intermittent operation. For a re-lubrication schedule, see Table 41. For any applications that are not in the ranges of the table, contact Daikin Applied.



The tables in this section state general lubrication recommendations based on our experience and are intended as suggested or starting points only. For best results, specific applications should be monitored regularly and lubrication intervals and amounts adjusted accordingly.

Any good quality lithium or lithium complex base grease, using mineral oil, conforming to NLGI grade 2 consistency, and an oil viscosity of 455-1135 SUS at 100°F (100-200 cSt at 40°C) may be used for re-lubrication.

Compatibility of grease is critical. Re-lubricatable bearings are supplied with grease fittings or zerks for ease of lubrication with hand or automatic grease guns. Always wipe the fitting and grease nozzle clean.

**Table 41: Re-lubrication Intervals**

Use NLGI #2 Lithium or Lithium Complex Grease

Speed	Bearing Temperature	Cleanliness	Relub. Intervals
100 rpm	Up to 120°F (50°C)	Clean	6 to 12 months
500 rpm	Up to 150°F (65°C)	Clean	2 to 6 months
1000 rpm	Up to 210°F (100°C)	Clean	2 weeks to 2 months
1500 rpm	Over 210°F (100°C) to 250°F (120°C)	Clean	Weekly
Above 1500 rpm	Up to 150°F (65°C)	Dirty/wet	1 week to 1 month
Max catalog rating	Over 150°F (65°C) to 250°F (120°C)	Dirty/wet	Daily to 2 weeks
	Above 250°F (120°C)		Contact Browning

**Table 42: Recommended Fan Re-lubrication Grease Charge**

Shaft Size – in. (mm)	Oz. (g)
1/2 to 3/4 (20)	0.03 (0.85)
7/8 to 1-3/16 (25-30)	0.10 (2.84)
1-1/4 to 1-1/2 (35-40)	0.15 (4.25)
1-11/16 to 1-15/16 (45-50)	0.20 (5.67)
2 to 2-7/16 (55-60)	0.30 (8.51)
2-1/2 to 2-15/16 (65-70)	0.50 (15.59)
3 to 3-7/16 (75-80)	0.85 (24.10)
3-1/2 to 4 (85-105)	1.50 (42.53)

## Fan Drive Adjustments

**WARNING**

Before servicing fan lock out and tag out all power to the unit. Fans or belts can cause severe personal injury or death.

**WARNING**

Do not open the hinged access door and screw-fastened access panels while the unit is operating. Moving parts and strong suction forces can cause severe personal injury or death.

**WARNING**

Moving belt and fan can cause severe personal injury or death.

During installation and filter maintenance:

- Verify that the belt and fan guards on plenum fan units are always in place.
- Lock and tag out fans to prevent accidental start up.
- Do not enter the filter compartment until the fan is completely stopped.
- Use approved equipment for reaching filters located above normal reach. Do not step on filter frames or unit components.
- Floor surfaces must be dry and free of oil or grease.

Upon completion of the air balance, replace the variable pitched motor sheave with a properly sized, fixed sheave. A matching fixed sheave provides longer belt and bearing life and minimizes vibration. Initially, it is best to have a variable pitched motor sheave for the purpose of air balancing. Once the balance is achieved, fixed sheaves maintain balancing and alignment more effectively. Replace the adjustable sheaves with fixed sheaves.

With the electrical power disconnected, locked and tagged out, measure the diameter of the V-belt outer surface where it passes around the sheave (pitch diameter). Calculate fan speed from the motor nameplate rpm.

$$\text{Fan rpm} = \text{motor rpm} \times \frac{\text{Measured diameter at motor sheave}}{\text{Measured diameter at fan sheave}}$$

## Fan Drive Belt Adjustment

### General Rules of Tensioning

1. The ideal tension is the lowest tension at which the belt does not slip under peak load conditions.
2. Check tension frequently during the first 24 to 48 hours of operation.
3. Over tensioning shortens belt and bearing life.
4. Keep belts free from foreign material that can cause slippage.
5. Inspect V-drive on a periodic basis. Adjust tension if the belt is slipping. Do not apply belt dressing. This can damage the belt and cause early failure.

### Tension Measurement Procedure

1. Measure the belt span. See Figure 78.
2. Place belt tension checker squarely on one belt at the center of the belt span. Apply force to the checker, perpendicular to the belt span, until the belt deflection equals belt span distance divided by 64. Determine the force applied while in this position.
3. Compare this force to the values in Table 43.

Figure 78: Drive Belt Adjustment

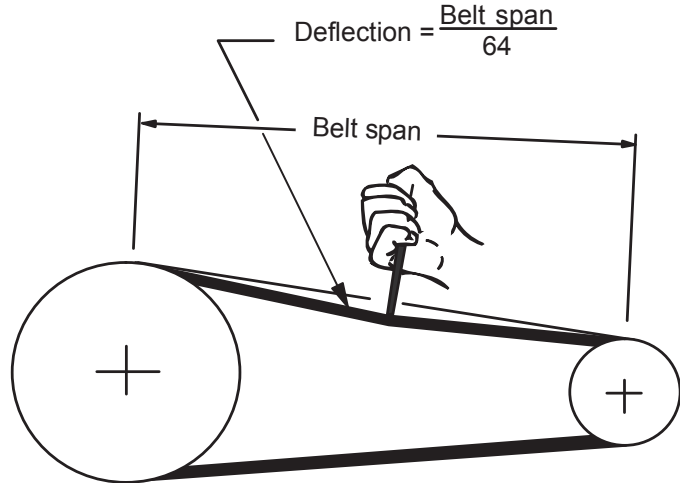


Table 43: Belt Deflection Force (per Browning Specifications)

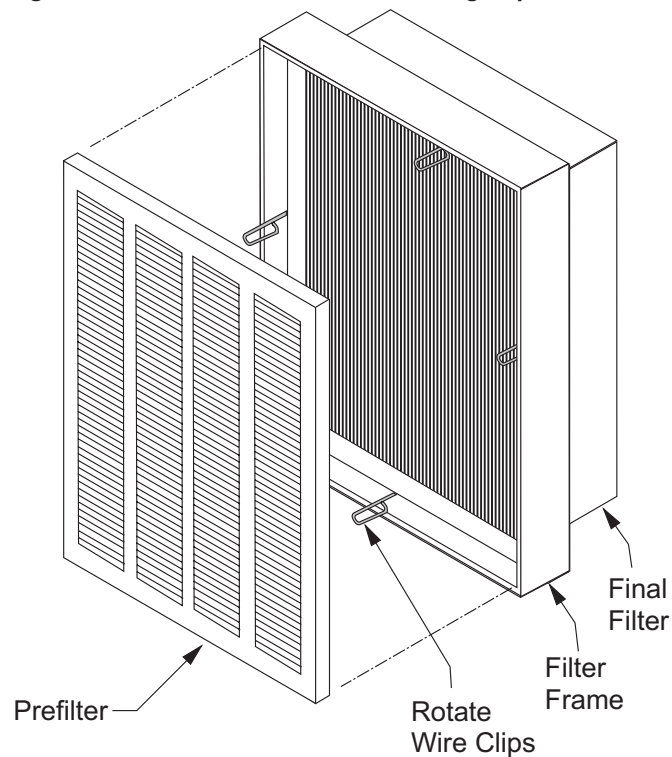
Cross section	Small sheave diameter (in)	Number of belts (deflection force lbs)					
		1		2		3 +	
		min	max	min	max	min	max
A, AX	0.0 to 3.5	3.0	5.0	2.5	4.0	2.0	3.5
	3.6 to 4.4	3.5	5.0	3.0	4.5	2.0	4.0
	4.5 +	4.0	5.5	3.0	5.0	2.5	4.5
B, BX	0.0 to 5.4	5.5	8.0	4.5	7.0	3.5	5.5
	5.5 to 7.6	5.5	8.5	4.5	7.5	3.5	5.5
	7.7 +	6.5	9.0	5.0	8.0	4.0	6.5
5V, 5VX	0.0 to 8.5	7.0	11.0	5.5	9.0	4.0	7.0
	0.6 to 12.0	8.5	13.0	6.5	10.5	5.0	8.0
	12.1 +	10.0	15.0	7.5	11.5	5.5	9.0

## Front Load Filter Option

Front loaded filter options require that the filters be removed and replaced from inside the unit.

To remove filters, rotate the wire clips. This releases both the prefilter and the final filter. When installing clean filters, check to verify the filters are fully seated in the frame. See [Figure 79](#).

**Figure 79: Frame and Filters with Holding Clips**



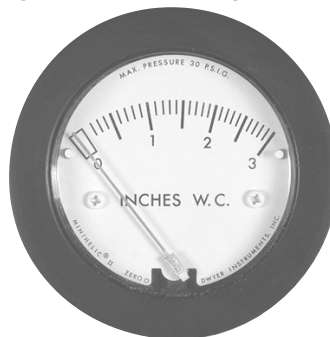
## Filter Gauges

Filter gauges indicate pressure drop for installed filters. If prefilters are present, the gauge will indicate the pressure drop for both pre-and final filters.

[Table 44](#) shows the typical filter pressure drop for clean filters at rated air flow. The tables also show a final pressure drop for front loaded filters.

Where a single filter gauge is used, the prefilters can be removed to check the pressure drop of the final filters.

**Figure 80: Filter Gauge**



**Table 44: Filter Pressure Drops - Flat Panel and High Efficiency Cartridge**

Flat Panel Filter																
Face Velocity	5700				PerfectPleatUltra				PerfectPleatHC				PerfectPleatUltra			
	2"-Side MERV 7		2"-Front MERV 7		2"-Side MERV 8		2"-Front MERV 8		4"-Side MERV 7		4"-Front MERV 7		4"-Side MERV 8		4"-Front MERV 8	
	Initial	Final	Initial	Final	Initial	Final	Initial	Final	Initial	Final	Initial	Final	Initial	Final	Initial	Final
500 fpm	0.22	1.00	0.27	1.00	0.36	1.00	0.42	1.00	0.20	1.00	0.27	1.00	0.36	1.00	0.47	1.00
Cartridge Filter																
Face Velocity	Varicel SH															
	12"-Side MERV 11		12"-Side MERV 13		12"-Side MERV 14		12"-Front MERV 11		12"-Front MERV 13		12"-Front MERV 14					
	Initial	Final	Initial	Final	Initial	Final	Initial	Final	Initial	Final	Initial	Final				
500 fpm	0.34	1.20	0.49	1.20	0.51	1.20	0.45	1.20	0.65	1.20	0.67	1.20				
Face Velocity	Varicel II MH															
	4"-Side MERV 11		4"-Side MERV 14		4"-Side MERV 15		4"-Front MERV 11		4"-Front MERV 14		4"-Front MERV 15					
	Initial	Final	Initial	Final	Initial	Final	Initial	Final	Initial	Final	Initial	Final				
500 fpm	0.38	1.50	0.55	1.50	0.63	1.50	0.46	1.50	0.65	1.50	0.74	1.50				
Face Velocity	Varicel V															
	4"-Side MERV 11		4"-Side MERV 14		4"-Side MERV 15		4"-Front MERV 11		4"-Front MERV 14		4"-Front MERV 15					
	Initial	Final	Initial	Final	Initial	Final	Initial	Final	Initial	Final	Initial	Final				
500 fpm	0.24	2.00	0.31	2.00	0.43	2.00	0.43	2.00	0.52	2.00	0.66	2.00				

**Table 45: Filter Pressure Drops - High Efficiency Bag**

Face Velocity	DriPak 2000															
	12"-Side MERV 8		12"-Front MERV 8		15"-Side MERV 8		15"-Front MERV 8		19"-Side MERV 8		19"-Front MERV 8		21"-Side MERV 11		21"-Front MERV 11	
	Initial	Final	Initial	Final	Initial	Final	Initial	Final	Initial	Final	Initial	Final	Initial	Final	Initial	Final
500 fpm	0.20	1.00	0.23	1.00	0.18	1.00	0.21	1.00	0.16	1.00	0.20	1.00	0.28	1.00	0.31	1.00
Face Velocity	30"-Side MERV 14															
	21"-Side MERV 14		21"-Front MERV 14		21"-Side MERV 15		21"-Front MERV 15		30"-Side MERV 11		30"-Front MERV 11		30"-Side MERV 14		30"-Front MERV 14	
	Initial	Final	Initial	Final	Initial	Final	Initial	Final	Initial	Final	Initial	Final	Initial	Final	Initial	Final
500 fpm	0.44	1.00	0.50	1.00	0.64	1.00	0.73	1.00	0.24	1.00	0.27	1.00	0.33	1.00	0.38	1.00
Face Velocity	36"-Side MERV 15															
	30"-Side MERV 15		30"-Front MERV 15		36"-Side MERV 11		36"-Front MERV 11		36"-Side MERV 14		36"-Front MERV 14		36"-Side MERV 15		36"-Front MERV 15	
	Initial	Final	Initial	Final	Initial	Final	Initial	Final	Initial	Final	Initial	Final	Initial	Final	Initial	Final
500 fpm	0.46	1.00	0.52	1.00	0.19	1.00	0.22	1.00	0.27	1.00	0.30	1.00	0.39	1.00	0.45	1.00

## Maintaining the Coil

### CAUTION

Sharp fin edges are a potential injury hazard. Avoid contact with them.

1. To obtain maximum performance, the coil must be clean. Check once a year under normal operating conditions and, if dirty, brush or vacuum clean. Use a chemical coil cleaner on multiple row coils. Read and follow the chemical cleaner's instructions as some cleaners may contain harsh chemicals. Take care not to damage fins while cleaning.
2. Drain pans in any air conditioning unit may have some moisture. Algae, etc., can grow due to airborne spores and bacteria. Periodic cleaning is necessary to prevent this buildup from plugging the drain and causing the drain pan to overflow. Also, keep the drain pans clean to prevent the spread of disease. Cleaning should be performed by qualified personnel.
3. Dirt and lint can clog the condensate drain, especially with dirty filters. Inspect twice a year to help avoid overflow.

## Winterizing Water Coils

### WARNING

Mold can cause personal injury. Clean drain pan regularly so mold does not develop.

Coils can freeze due to air stratification or failure of outdoor air dampers and/or preheat controls. Drain all coils as thoroughly as possible and then perform the following:

- Fill each coil independently with an antifreeze solution using a small circulating pump and again thoroughly drain.
- Check freezing point of antifreeze before proceeding to next coil. Due to a small amount of water always remaining in each coil, there is a diluting effect. The small amount of antifreeze solution remaining in the coil must always be sufficient enough to event freeze-up.

**NOTE:** Carefully read instructions for mixing antifreeze solution used. Some products have a higher freezing point in their natural state when mixed with water. Daikin Applied is not responsible for the freezing of coils.

## Removing and Replacing Components

### WARNING

Before removing any component, lock out and tag out all power to the unit. Fans and belts can cause severe personal injury or death.

### *Removing a Panel*

To Remove a Side or Top Panel:

1. Remove the flat head fasteners located along the sides of the panel.
2. Once all fasteners are removed, lift off the panel.

### *Removing a Frame Channel*

Frame channels that run the length of the unit along the top can be removed to allow access to both the side and top of the unit.

To Remove the Frame Channel:

1. First remove any adjoining side and top panel(s).
2. Once the side panel is off, remove the flat head fasteners in the corner of the frame channels.
3. Pull the frame channel out the side.

If any top panel fastens into the frame channel (when the frame channel is 24" or wider in direction of air flow), remove the fasteners in the top panel before pulling out the channel.

### *Removing the Fan Section*

The fan shaft, motor, and any drive components can be removed and replaced through the access door opening. If required, the side panel can be removed for additional access.

If fan replacement is required, the entire fan assembly can be pulled out the side of the cabinet for housed fan assemblies. The fan assembly includes the fan housing, the bearing support, and the fan base.

For plenum fan assemblies, the entire fan cabinet may need to be removed to replace the entire fan assembly depending on the length of the fan section. In some cases, the fan section is not long enough for the assembly to fit out the side of the cabinet. For those cases where it will fit, follow the above steps except the neoprene seal is a D-gasket on the inlet side that needs to be removed for plenum fans. Otherwise, the entire fan cabinet must be removed from the other sections and then the fan assembly can be removed out the discharge side of the cabinet.

## Removing the Fan Assembly

1. Remove the side panels and any intermediate supports (follow instructions for side panel removal).
2. Once the panels and any intermediate supports are removed, disconnect the neoprene bulk head seal that is attached to the fan discharge.
3. Remove the four discharge angles that hold the neoprene canvas in place around the discharge opening.
4. Disconnect the fan sled from each of the corner mounts and pull the entire assembly out the side of the unit.
5. After the fan sled is out, loosen the fan bearings and pull out the shaft.
6. Disconnect the fan housing from the fan sled, and bearing support by removing the attaching bolts.
7. Replace the new fan, reconnect the shaft and bearings and put the fan assembly in the cabinet.
8. Replace panels and fasteners.

## Removing and Replacing the Coil

The coil can be removed by the side, top, or a combination of both. The size and configuration of the coil affects how the coil can be removed. Single banks of coil are fastened only on the connection side of the unit. Stacked and staggered coils are fastened on both ends of the coil. See the instructions in this section for details to remove each coil type.

Before removing the coil, disconnect all piping. The instructions below assume the coil is mounted in a sectionalized coil section where the frame channel can be removed without affecting other components. If the coil section is unitized with other components, removing the top frame channel requires removing additional panels.

### Removing Single Coils

**NOTE:** Single coils are bolted to the unit on the connection end. The connection end is held in place with a clamp. See [Figure 81](#) and [Figure 82](#).

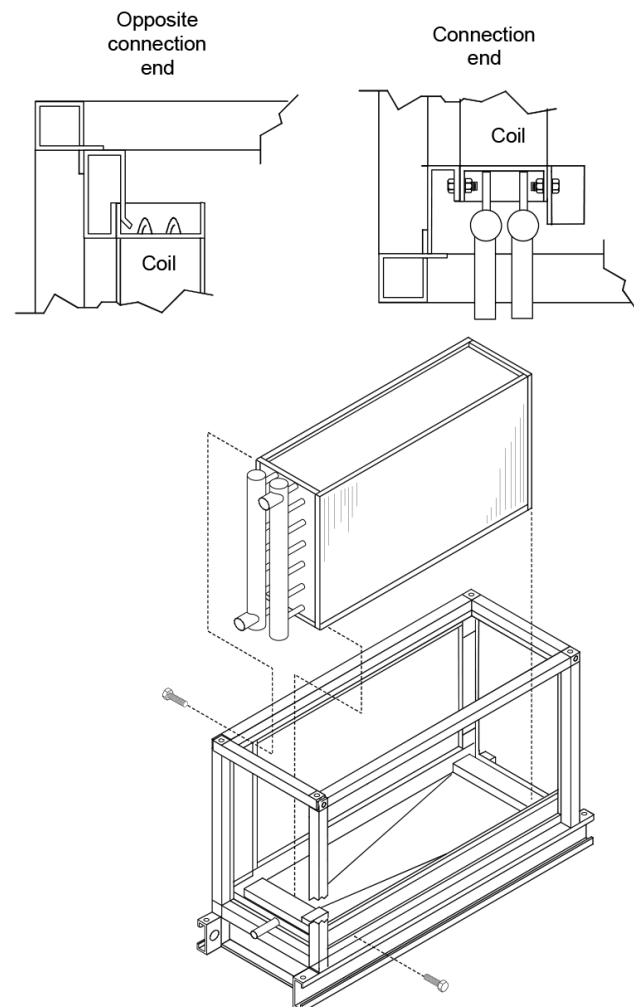
1. Disconnect all piping and remove the brass plugs for the vents and drains located in the connections.
2. Remove all screws and remove the access panel.
3. Remove the screws holding the coil in place.
4. Lift and pull the coil out the side.

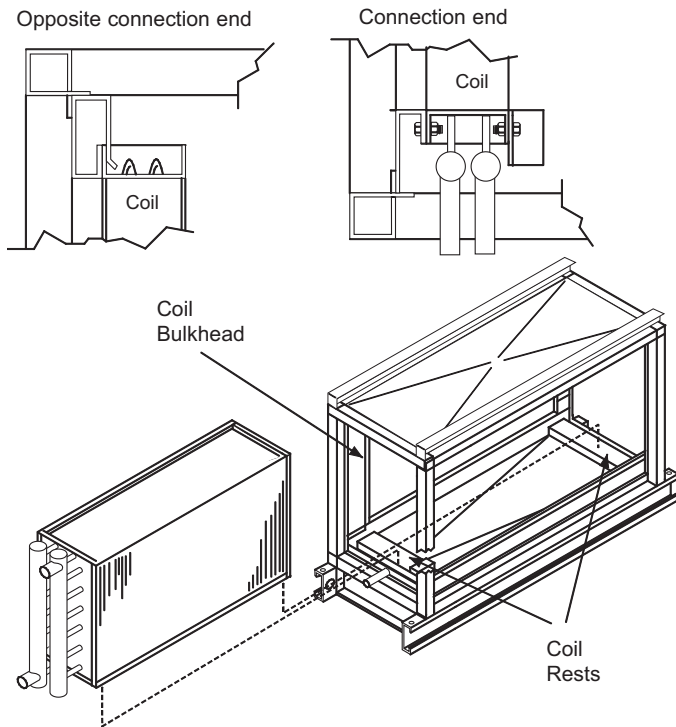
## Installing Single Coils

**NOTE:** Ensure the drain pan is fully sealed before installing the filler panel and coil panel. If gaps or damage is seen, refer to the procedure outlined in [See Field-Installed Coils on page 19](#).

1. Slide the coil through the opening in the coil section onto the bottom coil rests.
2. To prevent any air bypass around the coil, place coils up against the coil bulkheads. See [Figure 78](#) and [Figure 82](#).
3. Once the coil is in place, fasten the coil to the section.
4. Caulk the seams between the coil casings and bulkheads. See [Figure 81](#) and [Figure 82](#).
5. If this is an additional coil being installed and not a replacement, locate the coil supply and return connections dimensionally. Carefully drill holes in the end panels of the unit.
6. Remove the brass plugs for the vents and drains on the connections.
7. Slip the panel over the connections.
8. Replace the brass plugs and panel fasteners.

**Figure 81: Single Coil, Top Installation/Removal**



**Figure 82: Single Coil, Side Installation/Removal**

## Removing Stacked Coils

**NOTE:** Top and bottom stacked coils are held together with steel plate and screws on one side and drain trough and screws on the other side. Remove the plate and trough before removing the coils. The coils cannot be removed attached together.

1. Disconnect all piping and remove the brass plugs for the vents and drains located in the connections.
2. Remove all screws and remove the access panel.
3. Remove the bolts holding the coil in place and then lift and pull out the coil from the side.
4. Remove the steel plate and the drain trough that holds the coil together.
5. Remove the bolts on both ends of the top coil holding it in place and then lift and slide the coil out.
6. Remove the bolts on both ends of the bottom coil holding it in place and then lift and slide the coil out.

## Installing Stacked Coils

**NOTE:** Ensure the drain pan is fully sealed before installing the filler panel and coil panel. If gaps or damage is seen, refer to the procedure outlined in [See Field-Installed Coils on page 19](#).

1. Slide the bottom coil through the opening in the coil section onto the bottom coil rests.
2. Place the coil up against the coil bulkheads to prevent any air bypass around the coil.
3. Once the coil is in place, bolt the coil to the section.
4. Caulk the mounting surface of the steel plate and install the plate on the coils.
5. Caulk the mounting surface of the drain trough and install the drain trough on the coils.
6. Caulk the seams between the coil casings and blockoffs.
7. Connect all piping and install the brass plugs for the vents and drains located in the connections.
8. Install the access panel.

## Warranty Procedure

Consult your local Daikin Applied representative for warranty details. Refer to Form 933-430285Y. To find your local Daikin Applied representative, go to [www.DaikinApplied.com](http://www.DaikinApplied.com).

### Warranty Return Material Procedure

Defective material may not be returned without permission of authorized factory service personnel of Daikin Applied in Minneapolis, Minnesota, (763) 553-5330. A "Return Goods" tag must be included with the returned material. Enter the required information to expedite handling and prompt issuance of credits. All parts must be returned to the appropriate Daikin Applied facility, designated on the "Return Goods" tag. Transportation charges must be prepaid.

The return of the part does not constitute an order for replacement. Therefore, a purchase order must be entered through the nearest Daikin Applied representative. The order should include part number, model number, and serial number of the unit involved.

## Replacement Parts

When writing to Daikin Applied for service or replacement parts, refer to the model number and serial number of the unit stamped on the serial plate attached to the unit. If replacement parts are required, mention the date of installation of the unit and date of failure, along with an explanation of the malfunctions and a description of the replacement parts required.

# Limited Warranty



DAIKIN APPLIED AMERICAS INC.  
LIMITED PRODUCT WARRANTY  
(United States and Canada)

## WARRANTY

Daikin Applied Americas Inc. dba Daikin Applied (“Company”) warrants to contractor, purchaser and any owner of the product (collectively “Owner”) that, subject to the exclusions set forth below Company, at its option, will repair or replace defective parts in the event any product manufactured by Company, including products sold under the brand name Daikin and used in the United States or Canada, proves defective in material or workmanship within twelve (12) months from initial startup or eighteen (18) months from the date shipped by Company, whichever occurs first. Authorized replacement parts are warranted for the remainder of the original warranty. All shipments of such parts will be made FOB factory, freight prepaid and allowed. Company reserves the right to select carrier and method of shipment. In addition, Company provides labor to repair or replace warranty parts during Company normal working hours on products with rotary screw compressors or centrifugal compressors. Warranty labor is not provided for any other products.

Company must receive the Registration and Startup Forms for products containing motor compressors and/or furnaces within ten (10) days of original product startup, or the ship date and the startup date will be deemed the same for determining the commencement of the warranty period and this warranty shall expire twelve (12) months from that date. For additional consideration, Company will provide an extended warranty(ies) on certain products or components thereof. The terms of the extended warranty(ies) are shown on a separate extended warranty statement.

No person (including any agent, sales representative, dealer or distributor) has the authority to expand the Company’s obligation beyond the terms of this express warranty or to state that the performance of the product is other than that published by Company.

## EXCLUSIONS

1. If free warranty labor is available as set forth above, such free labor does not include diagnostic visits, inspections, travel time and related expenses, or unusual access time or costs required by product location.
2. Refrigerants, fluids, oils and expendable items such as filters are not covered by this warranty.
3. This warranty shall not apply to products or parts : (a) that have been opened, disassembled, repaired, or altered, in each case by anyone other than Company or its authorized service representative; (b) that have been subjected to misuse, abuse, negligence, accidents, damage, or abnormal use or service; (c) that have not been properly maintained; (d) that have been operated or installed, or have had startup performed, in each case in a manner contrary to Company’s printed instructions; (e) that have been exposed, directly or indirectly, to a corrosive atmosphere or material such as, but not limited to, chlorine, fluorine, fertilizers, waste water, urine, rust, salt, sulfur, ozone, or other chemicals, contaminants, minerals, or corrosive agents; (f) that were manufactured or furnished by others and/or are not an integral part of a product manufactured by Company; or (g) for which Company has not been paid in full.
4. This warranty shall not apply to products with rotary screw compressors or centrifugal compressors if such products have not been started, or if such startup has not been performed, by a Daikin Applied or Company authorized service representative.

## SOLE REMEDY AND LIMITATION OF LIABILITY

THIS WARRANTY CONSTITUTES THE SOLE WARRANTY MADE BY COMPANY. COMPANY’S LIABILITY TO OWNER AND OWNER’S SOLE REMEDY UNDER THIS WARRANTY SHALL NOT EXCEED THE LESSER OF: (i) THE COST OF REPAIRING OR REPLACING DEFECTIVE PRODUCTS; AND (ii) THE ORIGINAL PURCHASE PRICE ACTUALLY PAID FOR THE PRODUCTS. COMPANY MAKES NO REPRESENTATION OR WARRANTY, EXPRESS OR IMPLIED, REGARDING PREVENTION OF MOLD/MOULD, FUNGUS, BACTERIA, MICROBIAL GROWTH, OR ANY OTHER CONTAMINATES. THIS WARRANTY IS GIVEN IN LIEU OF ALL OTHER WARRANTIES, INCLUDING, WITHOUT LIMITATION, THE IMPLIED WARRANTIES OF MERCHANTABILITY, FITNESS FOR A PARTICULAR PURPOSE, AND NON-INFRINGEMENT, WHICH ARE HEREBY DISCLAIMED. IN NO EVENT AND UNDER NO CIRCUMSTANCE SHALL COMPANY BE LIABLE TO OWNER OR ANY THIRD PARTY FOR INCIDENTAL, INDIRECT, SPECIAL, CONTINGENT, CONSEQUENTIAL, DELAY OR LIQUIDATED DAMAGES FOR ANY REASON, ARISING FROM ANY CAUSE WHATSOEVER, WHETHER THE THEORY FOR RECOVERY IS BASED IN LAW OR IN EQUITY, OR IS UNDER A THEORY OF BREACH CONTRACT OR WARRANTY, NEGLIGENCE, STRICT LIABILITY, OR OTHERWISE. THE TERM “CONSEQUENTIAL DAMAGE” INCLUDES, WITHOUT LIMITATION, THOSE DAMAGES ARISING FROM BUSINESS INTERRUPTION OR ECONOMIC LOSS, SUCH AS LOSS OF ANTICIPATED PROFITS, REVENUE, PRODUCTION, USE, REPUTATION, DATA OR CROPS.

## ASSISTANCE

To obtain assistance or information regarding this warranty, please contact your local sales representative or a Daikin Applied office.

Form No. 933-430285Y-01-A (11/2023)  
Part No. 043028500 Rev.0F

# Warranty Registration Form



## Air Handling Equipment Warranty Registration Form

To comply with the terms of Daikin Applied Warranty, register the start date and upload this form within 10 days to the Warranty Department of Daikin Applied.

Check, test, and start procedure for air handling units with or without heat recovery and roof mounted air handlers.

### GENERAL INFORMATION

Job Name: \_\_\_\_\_ Unit No.: \_\_\_\_\_

SOI No.: \_\_\_\_\_

Installation address: \_\_\_\_\_

City: \_\_\_\_\_ State: \_\_\_\_\_

Purchasing contractor: \_\_\_\_\_

City: \_\_\_\_\_ State: \_\_\_\_\_

Name of person doing start-up: \_\_\_\_\_

Company name: \_\_\_\_\_

Address: \_\_\_\_\_

City/State/Zip: \_\_\_\_\_

### UNIT INFORMATION

Unit model number: \_\_\_\_\_ Unit serial number: \_\_\_\_\_

SF VFD model number: \_\_\_\_\_ Serial number: \_\_\_\_\_

RF VFD model number: \_\_\_\_\_ Serial number: \_\_\_\_\_



AHU Equipment Warranty Registration Form (continued)

Select Yes or No. If not applicable to the type of unit, select N/A.

I. INITIAL CHECK

- A. Is any shipping damage visible? . . . . .  Yes  No  N/A
- B. Are fan drives properly aligned and belts properly adjusted? . . . . .  Yes  No  N/A
- C. Tightened all setscrews on pulleys, bearings and fans? . . . . .  Yes  No  N/A
- D. Have the hold-down bolts been backed off on spring mounted fan isolators? . . . . .  Yes  No  N/A
- E. With the power off, do fans turn freely by hand? . . . . .  Yes  No  N/A
- F. Electrical service corresponds to unit nameplate? . . . . .  Yes  No  N/A

Volts \_\_\_\_\_ Hertz \_\_\_\_\_ Phase \_\_\_\_\_

- G. Is the main disconnect adequately fused and are fuses installed? . . . . .  Yes  No  N/A
- H. Are all electrical power connections tight? (Check compressor, electrical box.) . . . . .  Yes  No  N/A
- I. Is the condensate drain trapped? . . . . .  Yes  No  N/A
- J. Fill the drain pan. Does water drain freely? . . . . .  Yes  No  N/A
- K. Is the unit mounted level? . . . . .  Yes  No  N/A

II. FAN DATA

- A. Check rotation of supply fan(s)? . . . . .  Yes  No  N/A
- B. Voltage at supply fan motor(s): . . . . . 1-2 \_\_\_\_\_ V 2-3 \_\_\_\_\_ V 1-3 \_\_\_\_\_ V  
 \*Fan array units only . . . . . 1-2 \_\_\_\_\_ V 2-3 \_\_\_\_\_ V 1-3 \_\_\_\_\_ V  
 1-2 \_\_\_\_\_ V 2-3 \_\_\_\_\_ V 1-3 \_\_\_\_\_ V  
 1-2 \_\_\_\_\_ V 2-3 \_\_\_\_\_ V 1-3 \_\_\_\_\_ V  
 1-2 \_\_\_\_\_ V 2-3 \_\_\_\_\_ V 1-3 \_\_\_\_\_ V  
 1-2 \_\_\_\_\_ V 2-3 \_\_\_\_\_ V 1-3 \_\_\_\_\_ V
- C. Supply fan motor amp draw(s) per phase: . . . . . L1 \_\_\_\_\_ L2 \_\_\_\_\_ L3 \_\_\_\_\_  
 \*Fan array units only . . . . . L1 \_\_\_\_\_ L2 \_\_\_\_\_ L3 \_\_\_\_\_  
 L1 \_\_\_\_\_ L2 \_\_\_\_\_ L3 \_\_\_\_\_  
 L1 \_\_\_\_\_ L2 \_\_\_\_\_ L3 \_\_\_\_\_  
 L1 \_\_\_\_\_ L2 \_\_\_\_\_ L3 \_\_\_\_\_  
 L1 \_\_\_\_\_ L2 \_\_\_\_\_ L3 \_\_\_\_\_
- D. Overload amp setting: . . . . . \_\_\_\_\_
- E. What is the supply fan rpm? . . . . . \_\_\_\_\_
- F. Check rotation of return fan(s)? . . . . .  Yes  No  N/A



AHU Equipment Warranty Registration Form (continued)

Select Yes or No. If not applicable to the type of unit, select N/A.

G. Voltage at return fan motor(s): . . . . . 1-2 \_\_\_\_\_ V 2-3 \_\_\_\_\_ V 1-3 \_\_\_\_\_ V  
 \*Fan array units only . . . . . 1-2 \_\_\_\_\_ V 2-3 \_\_\_\_\_ V 1-3 \_\_\_\_\_ V  
 1-2 \_\_\_\_\_ V 2-3 \_\_\_\_\_ V 1-3 \_\_\_\_\_ V  
 1-2 \_\_\_\_\_ V 2-3 \_\_\_\_\_ V 1-3 \_\_\_\_\_ V  
 1-2 \_\_\_\_\_ V 2-3 \_\_\_\_\_ V 1-3 \_\_\_\_\_ V  
 1-2 \_\_\_\_\_ V 2-3 \_\_\_\_\_ V 1-3 \_\_\_\_\_ V

H. Return fan motor amp draw(s) per phase: . . . . . L1 \_\_\_\_\_ L2 \_\_\_\_\_ L3 \_\_\_\_\_  
 \*Fan array units only . . . . . L1 \_\_\_\_\_ L2 \_\_\_\_\_ L3 \_\_\_\_\_  
 L1 \_\_\_\_\_ L2 \_\_\_\_\_ L3 \_\_\_\_\_  
 L1 \_\_\_\_\_ L2 \_\_\_\_\_ L3 \_\_\_\_\_  
 L1 \_\_\_\_\_ L2 \_\_\_\_\_ L3 \_\_\_\_\_  
 L1 \_\_\_\_\_ L2 \_\_\_\_\_ L3 \_\_\_\_\_

I. Overload amp setting: . . . . . \_\_\_\_\_

J. What is the return fan rpm? . . . . . \_\_\_\_\_

K. Record supply static pressure at unit in inches of H<sub>2</sub>O: . . . . . \_\_\_\_\_

L. Record return static pressure at unit (with outside air dampers closed) in inches of H<sub>2</sub>O: . . . . . \_\_\_\_\_

\* If additional fans are on the unit, please add them to the space below.

III. DAMPERS

A. Are blades and seals present? . . . . .  Yes  No  N/A

B. Do damper open smoothly and shut tight? . . . . .  Yes  No  N/A



AHU Equipment Warranty Registration Form (continued)

Select Yes or No. If not applicable to the type of unit, select N/A.

IV. ELECTRIC HEAT

A. Electrical heat service corresponds to unit nameplate? . . . . .  Yes  No  N/A

Volts \_\_\_\_\_ Hertz \_\_\_\_\_ Phase \_\_\_\_\_

B. Are there any signs of physical damage to the electric heat coils? . . . . .  Yes  No  N/A

C. Have all electrical terminals been tightened? . . . . .  Yes  No  N/A

D. Does sequence controller stage contactors properly? . . . . .  Yes  No  N/A

E. Electric heater voltage across each phase: . . . . . \_\_\_\_\_ L1 \_\_\_\_\_ L2 \_\_\_\_\_ L3

F. Amp draw across each phase at each heating stage:

	Stage 1	Stage 2	Stage 3	Stage 4	Stage 5	Stage 6
Phase L1:	_____	_____	_____	_____	_____	_____
Phase L2:	_____	_____	_____	_____	_____	_____
Phase L3:	_____	_____	_____	_____	_____	_____

G. FLA: L1 \_\_\_\_\_ L2 \_\_\_\_\_ L3 \_\_\_\_\_

H. Operate electric heat with fans off. Electric heat must cycle on high limit control . . . . .  Yes  No  N/A

V. CHILLED WATER COIL

A. Pressure test OK? . . . . .  Yes  No  N/A

B. Drain pan draining OK? . . . . .  Yes  No  N/A

VI. HOT WATER COIL

A. Pressure test OK? . . . . .  Yes  No  N/A

VII. HEAT RECOVERY

A. Heat wheel rotates freely? . . . . .  Yes  No  N/A

B. Heat wheel VFD operates properly? . . . . .  Yes  No  N/A

C. Heat wheel VFD: . . . . . Model # \_\_\_\_\_ Serial # \_\_\_\_\_

D. Check for air bypass around heat wheel. . . . .  Yes  No  N/A



AHU Equipment Warranty Registration Form (continued)

Select Yes or No. If not applicable to the type of unit, select N/A.

VIII. Design Flow calibration

- A. Verify power is supplied to the MicroTech III unit controller . . . . .  Yes  No  N/A
- B. Verify that the shipping screws have been removed from the measuring station vane . . . . .  Yes  No  N/A
- C. Examine station for damage . . . . .  Yes  No  N/A
- D. Record Level Position after calibration
  - LH Level Position . . . . . \_\_\_\_\_
  - RH Level Position . . . . . \_\_\_\_\_

NOTE: This is viewed in the MicroTech III controller, in the Min OA setup menu.

IX. GAS BURNER CHECK, TEST, & START

Specifications:

For gas, see **Forced Draft Gas Burner Installation and Maintenance Bulletin. (IM 684 and IM 685)**

- A. Gas Furnace: . . . . . Model no. \_\_\_\_\_
- B. Gas Burner: . . . . . Model no. \_\_\_\_\_ Serial no. \_\_\_\_\_
- C. Gas Type firing: . . . . . Single Stage \_\_\_\_\_ Modulation \_\_\_\_\_
- D. Gas Rated firing rate (MBH input): . . . . . \_\_\_\_\_
- E. Gas Altitude (ft. above sea level): . . . . . \_\_\_\_\_
- F. Is there a circulating tank? . . . . .  Yes  No  N/A
- G. Input (CFH): . . . . . \_\_\_\_\_
- H. Gas pressure at burner (inches w.c.): . . . . . \_\_\_\_\_
- I. CO<sub>2</sub> (%): . . . . . \_\_\_\_\_
- J. CO<sub>2</sub> (%): . . . . . \_\_\_\_\_
- K. Pilot flame only in microamps (steady at low fire): . . . . . \_\_\_\_\_
- L. Pilot Tap-gas pressure (inches w.c.): . . . . . \_\_\_\_\_
- M. Motor only/burner FLA running amps: . . . . . \_\_\_\_\_
- N. High limit control OK? . . . . .  Yes  No  N/A
- O. Flame safeguard (microamps): . . . . . \_\_\_\_\_
- P. Flame failure shutoff (seconds): . . . . . \_\_\_\_\_



AHU Equipment Warranty Registration Form (continued)

Select Yes or No. If not applicable to the type of unit, select N/A.

- Q. Airswitch OK? . . . . .  Yes  No  N/A
- R. High Gas Pressure Switch OK? . . . . .  Yes  No  N/A
- S. Low Gas Pressure Switch OK? . . . . .  Yes  No  N/A
- T. Main Gas Valve Close-off OK? . . . . .  Yes  No  N/A

Thank you for completing this form. Please sign and date below.

Signature \_\_\_\_\_ Startup date: \_\_\_\_\_

Register equipment start date and upload form on the Daikin Applied FieldCare Portal at <https://fieldcare.daikinapplied.com>

Please fill out the Daikin Applied "Quality Assurance Survey Report" and list any additional comments that could affect the operation of this unit; e.g., shipping damage, failed components, adverse installation applications, etc. If additional comment space is needed, write the comment(s) on a separate sheet, attach it to the Survey Report and return it to the Warranty Department of Daikin Applied with the completed Equipment Warranty Registration form.

Clear Form

# Quality Assurance Survey Report



## Quality Assurance Survey Report

To whom it may concern:

Please review the items below upon receiving and installing our product. Select N/A on any item that does not apply to the product.

**Job Name:** \_\_\_\_\_ **Daikin Applied S.O. No.** \_\_\_\_\_

Installation address: \_\_\_\_\_

City: \_\_\_\_\_ State: \_\_\_\_\_

Purchasing contractor: \_\_\_\_\_

City: \_\_\_\_\_ State: \_\_\_\_\_

**Name of person doing start-up (print):** \_\_\_\_\_

Company name: \_\_\_\_\_

Address: \_\_\_\_\_

City/State/Zip: \_\_\_\_\_

**Unit model number:** \_\_\_\_\_ **Unit serial number:** \_\_\_\_\_

1. Is there any shipping damage visible? ..... Yes  No  N/A

Location on unit \_\_\_\_\_

2. How would you rate the overall appearance of the product; i.e., paint, fin damage, etc.? ..... Excellent  Good  Fair  Poor

3. Did all sections of the unit fit together properly? ..... Yes  No  N/A

4. Did the cabinet have any air leakage? ..... Yes  No  N/A

Location on unit \_\_\_\_\_

5. Were there any refrigerant leaks? ..... Yes  No  N/A

From where did it occur? ..... Shipping  Workmanship  Design

6. Does the refrigerant piping have excessive vibration? ..... Yes  No  N/A

Location on unit \_\_\_\_\_

7. Did all of the electrical controls function at start-up? ..... Yes  No  N/A

Comments \_\_\_\_\_

8. Did the labeling and schematics provide adequate information? ..... Yes  No  N/A

9. How would you rate the serviceability of the product? ..... Excellent  Good  Fair  Poor

10. How would you rate the overall quality of the product? ..... Excellent  Good  Fair  Poor

11. How does the quality of Daikin Applied products rank in relation to competitive products? ..... Excellent  Good  Fair  Poor

Comments \_\_\_\_\_

Please list any additional comments which could affect the operation of this unit; i.e., shipping damage, failed components, adverse installation applications, etc. If additional comment space is needed, write the comment(s) on a separate sheet, attach the sheet to this completed Quality Assurance Survey Report, and return it to the Warranty Department with the completed preceding "Equipment Warranty Registration Form".

# COMPLETE HVAC SYSTEM SOLUTIONS

SELF-CONTAINED | ROOFTOPS | COILS | CONDENSING UNITS  
AIR HANDLERS | WATER-COOLED CHILLERS | AIR-COOLED CHILLERS  
MODULAR CENTRAL PLANTS | CONNECTED BUILDING CONTROLS  
UNIT HEATERS | FAN COILS | AIR PURIFIERS | WATER SOURCE HEAT PUMPS  
VARIABLE AIR VOLUME UNITS | UNIT VENTILATORS



13600 INDUSTRIAL PARK BLVD. | MINNEAPOLIS, MN 55441  
1-800-432-1342 | 763-553-5330

LEARN MORE AT  
**DAIKINAPPLIED.COM**

PART NUMBER: IM915

© 2026 DAIKIN APPLIED | (800) 432.1342 | WWW.DAIKINAPPLIED.COM