

SMARTSOURCE[®]

VERTICAL WATER SOURCE HEAT PUMP



- MODEL WSCV, WSMV, WSSV, WSTV
- SIZES 007 – 070 (1/2 TO 6 TONS)
- R-32 REFRIGERANT

Safety Information	3	Operation	51
Hazard Identification	3	Start-Up.....	51
Safety Considerations.....	3	Controls.....	52
UL Compliance Statements for Unit Work.....	4	Configuration DIP Switches.....	54
Unit Labels	4	MicroTech SmartSource Unit Controller	55
Introduction	5	MT2300 Controller with an Optional BACnet® Communication Module	58
Model Nomenclature.....	5	Maintenance	59
Installation	9	Troubleshooting.....	60
Receiving and Handling	9	Refrigerant Information	61
Operating Limits	9	Refrigerant Guidelines	61
Pre-Installation	10	Typical Refrigeration Cycles	64
Unit Location and Clearances	11	Appendix	66
Water Piping	12	Warranty Registration Form	66
Condensate Drain.....	13	Limited Product Warranty	69
Water System Quality	14		
Cleaning & Flushing System.....	14		
Piping Considerations for Units with Waterside Economizer	16		
Ductwork and Attenuation	22		
Field Installed Accessories	27		
Motorized Isolation Valve Kit	27		
Electrical	28		
230 Volt Operation	28		
Three-Phase Line Voltage (208-230, 460, 575V) ...	28		
Single Phase Line Voltage (115, 208-230, 265V) ...	29		
Low Voltage Wire Connections	31		
Control Wiring Schematics	32		
Line Voltage Wiring Schematics	39		
Typical Connections for Thermostats & Temperature Sensors Applications	48		



©2024 Daikin Applied, Minneapolis, MN. All rights reserved throughout the world. This document contains the most current product information as of this printing. Daikin Applied Americas Inc. has the right to change the information, design, and construction of the product represented within the document without prior notice. For the most up-to-date product information, please go to www.DaikinApplied.com.

™ SmartSource, MicroTech, SiteLine, and Daikin Applied are trademarks or registered trademarks of Daikin Applied Americas Inc. The following are trademarks or registered trademarks of their respective companies: BACnet from American Society of Heating, Refrigerating and Air-Conditioning Engineers, Inc.; Echelon, LonWorks, LonMark, and LonTalk from Echelon Corporation; Modbus from Schneider Electric; and Windows from Microsoft Corporation.

Safety Information

Hazard Identification

DANGER

Danger indicates a hazardous situation, which will result in death or serious injury if not avoided.

WARNING

Warning indicates a potentially hazardous situations, which can result in property damage, personal injury, or death if not avoided.

CAUTION

Caution indicates a potentially hazardous situations, which can result in minor injury or equipment damage if not avoided.

NOTICE

Notice indicates practices not related to physical injury.

NOTE: Indicates important details or clarifying statements for information presented in Figures or Tables.

Safety Considerations

This manual provides installation and maintenance information for Daikin Applied SMARTSOURCE WSHP VERTICAL with a MicroTech® controller.

NOTICE

Installation and maintenance are to be performed only by licensed, if required by local codes and regulations, or qualified personnel who are familiar with local codes and regulations and are experienced with this type of equipment.

A means for disconnection must be incorporated in the fixed wiring in accordance with the wiring rules for stationary appliances not fitted with means for disconnection from the supply mains having a contact separation in all poles that provide full disconnection under overvoltage category III.

DANGER

LOCKOUT/TAGOUT all power sources prior to service, pressurizing, depressuring, or powering down the unit. Failure to follow this warning exactly can result in serious injury or death. Disconnect electrical power before servicing the equipment. More than one disconnect may be required to de-energize the unit. Be sure to read and understand the installation, operation, and service instructions within this manual.

WARNING

Electric shock hazard. Improper handling of this equipment can cause personal injury or equipment damage. This equipment must be properly grounded. Connections to and service of the MicroTech control panel must be performed only by personnel that are knowledgeable in the operation of the equipment being controlled.

WARNING



This unit contains R-32, a class A2L refrigerant that is flammable. This unit should only be installed, serviced, repaired, and disposed of by qualified personnel licensed or certified in their jurisdiction to work with R-32 refrigerant. Installation and maintenance must be done in accordance with this manual. Improper handling of this equipment can cause equipment damage or personal injury.

For installation only in locations not accessible to the general public.

Be aware that R-32 refrigerant may not contain an odor. Place in a well ventilated area to prevent accumulation of refrigerant. When installing the unit in a small room, take measures to keep the refrigerant concentration from exceeding allowable safety limits. Excessive refrigerant leaks, in the event of an accident in a closed ambient space, can lead to oxygen deficiency.

Do not pierce or burn this unit.

Never use an open flame during service or repair. Never store in a room with continuously operating ignition sources (for example: open flames, an operating gas appliance, or and operating electric heater.), where there is ignitable dust suspension in the air, or where volatile flammables such as thinner or gasoline are handled.

Only use pipes, nuts, and tools intended for exclusive use with R-32 refrigerant in compliance with national codes (ASHRAE15 or IRC).

Do not mix air or gas other than R-32 in the refrigerant system. If air enters the refrigerant system, an excessively high pressure results, which may cause equipment damage or injury.

Do not use means to accelerate the defrosting process or to clean, other than those recommended by the manufacturer.

For more information, consult "[Refrigerant Information](#)" on page 61.

WARNING

Polyolester Oil, commonly known as POE oil is a synthetic oil used in many refrigeration systems, and may be present in this Daikin Applied product. POE oil, if ever in contact with PVC/CPVC, will coat the inside wall of PVC/CPVC pipe causing environmental stress fractures. Although there is no PVC/CPVC piping in this product, please keep this in mind when selecting piping materials for your application, as system failure and property damage could result. Refer to the pipe manufacturer's recommendations to determine suitable applications of the pipe.

WARNING

This equipment generates, uses, and can radiate radio frequency energy. If not installed and used in accordance with this instruction manual, it may cause interference with radio communications. Operation of this equipment in a residential area is likely to cause harmful interference in which case the owner will be required to correct the interference at the owner's own expense.

Daikin Applied disclaims any liability resulting from any interference or for the correction thereof.

WARNING

When moving flammable A2L refrigerant to/from the unit from an auxiliary tank, a grounding strap must be used. An electrical charge builds when halo-carbon refrigerant travels in a rubber hose. A grounding strap must be used between the auxiliary refrigerant tank and the unit's end sheet (earth ground), which will safely take the charge to the ground. A fire risk could occur if this procedure is not followed.

CAUTION

Static sensitive components. A static discharge while handling electronic circuit boards can cause damage to the components. Discharge any static electrical charge by touching the bare metal inside the control panel before performing any service work. Never unplug any cables, circuit board terminal blocks, or power plugs while power is applied to the panel.







UL Compliance Statements for Unit Work

- All maintenance staff and others working in the local area shall be instructed on the nature of work being carried out. Work in confined spaces shall be avoided.
- Work shall be undertaken under a controlled procedure so as to minimize the risk of a flammable gas or vapor being present while the work is being performed.
- The area shall be checked with an appropriate refrigerant detector prior to and during work, to ensure the technician is aware of potentially toxic or flammable atmospheres. Ensure that the leak detection equipment being used is suitable for use with all applicable refrigerants, i.e., non-sparking, adequately sealed or intrinsically safe.
- If any hot work is to be conducted on the refrigerating equipment or any associated parts, appropriate fire extinguishing equipment shall be available to hand. Have a dry powder or CO2 fire extinguisher adjacent to the charging area.
- No person carrying out work in relation to a refrigerating system which involves exposing any pipe work shall use any sources of ignition in such a manner that it may lead to the risk of fire or explosion. All possible ignition sources, including cigarette smoking, should be kept sufficiently far away from the site of installation, repairing, removing and disposal, during which refrigerant can possibly be released to the surrounding space.
- Prior to work taking place, the area around the equipment is to be surveyed to make sure that there are no flammable hazards. Safety checks are necessary to ensure that the risk of ignition is minimized and "No Smoking" signs shall be displayed.
- Ensure that the area is in the open or that it is adequately ventilated before breaking into the system or conducting any hot work. A degree of ventilation shall continue during the period that the work is carried out. The ventilation should safely disperse any released refrigerant and preferably expel it externally into the atmosphere.

- Equipment not to be used by persons (including children) with reduced physical, sensory or mental capabilities, or lack of experience and knowledge, unless they have been given supervision or instruction.
- Children shall not be allowed to play on or with equipment.
- If unit is permanently connected to water main; hose sets are not to be used.

Unit Labels

Pictogram warning and informational labels may be present on the unit. Consult the table below for reference.

Label	Description
 Refrigerant class per ISO 817	WARNING - flammable refrigerant present
	Read the technical manual for service instructions
	WARNING - A2L low-burning velocity refrigerant present
	Pressurized medium present
	Ultraviolet (UV) radiation present
	Read the technical manual for instructions
	WARNING - flammable refrigerant present

Introduction

Model Nomenclature

1	2-3	4	5-7	8	9	10	11-12	13	14	15	16	17	18	19	20	21-22	23	24	25	26	27	28	29	30	31	32	33	34
W	SC	V	007	E	1	F	LT	C	M	T	P	A	Y	Y	1	YY	A	Y	Y	Y	Y	Y	S	S	Y	Y	Y	L
Category		Code Option		Code		=		Description																				
Product Category		1		W		=		Water Source Heat Pump																				
Model Type		2-3		SC		=		SmartSource Small Capacity Compact - 1 Stage																				
				SM		=		SmartSource Small Capacity Plus - 1 Stage																				
				SS		=		SmartSource Small Capacity Premium - 1 Stage																				
				ST		=		SmartSource Small Capacity Premium - 2 Stage (Sizes 024-070)																				
Configuration		4		V		=		Vertical																				
Nominal Capacity		5-7		007		=		7,000 Btuh Nominal Cooling																				
				009		=		9,000 Btuh Nominal Cooling																				
				012		=		12,000 Btuh Nominal Cooling																				
				015		=		15,000 Btuh Nominal Cooling																				
				019		=		19,000 Btuh Nominal Cooling																				
				024		=		24,000 Btuh Nominal Cooling																				
				030		=		30,000 Btuh Nominal Cooling																				
				036		=		36,000 Btuh Nominal Cooling																				
				042		=		42,000 Btuh Nominal Cooling																				
				048		=		48,000 Btuh Nominal Cooling																				
060		=		60,000 Btuh Nominal Cooling																								
070		=		70,000 Btuh Nominal Cooling (WSCV, WSSV & WSTV)																								
Voltage		8		A		=		115/60/1 (Sizes 007-015)																				
				E		=		208-230/60/1 (Sizes 007-070)																				
				F		=		208-230/60/3 (Sizes 024-070)																				
				J		=		265/60/1 (Sizes 007-036)																				
				K		=		460/60/3 (Sizes 024-070)																				
				L		=		575/60/3 (Sizes 048-070)																				
Design Series (Vintage)		9		1		=		Design Series 1																				
Piping Hand		10		F		=		Front																				
Cabinet Configuration		11-12		LT		=		Left Hand Return / Top Discharge																				
				RT		=		Right Hand Return / Top Discharge																				
Water Coil Type		13		C		=		Copper Inner Tube (WSCV & WSMV)																				
				G		=		Copper Inner Tube - Geothermal (WSCV & WSMV)																				
				B		=		Braze Plate Heat Exchanger (WSSV & WSTV)																				
				H		=		Braze Plate Heat Exchanger - Geothermal (WSSV & WSTV)																				
				S		=		Cupronickel Inner Tube (WSCV & WSMV)																				
				J		=		Cupronickel Inner Tube - Geothermal (WSCV & WSMV)																				
Unit Control		14		M		=		MicroTech Unit Controller																				
				B		=		MicroTech Unit Controller + BACnet																				
Controller Options		15		T		=		Thermostat Control																				
				S		=		Sensor Control																				

1	2-3	4	5-7	8	9	10	11-12	13	14	15	16	17	18	19	20	21-22	23	24	25	26	27	28	29	30	31	32	33	34
W	SC	V	007	E	1	F	LT	C	M	T	P	A	Y	Y	1	YY	A	Y	Y	Y	Y	Y	S	S	Y	Y	Y	L
Category		Code Option		Code		=		Description																				
Fan Motor Options		16		P		=		PSC (WSCV and WSMV)																				
				C		=		ECM Constant CFM (Sizes 015-070)																				
				T		=		ECM Constant Torque (N/A for WSTV)																				
Insulation (Compressor Side and Air Side)		17		A		=		Standard - Fiberglass																				
				B		=		IAQ - Closed Cell Foam																				
				C		=		Sound Package - Dual Layer Fiberglass																				
				D		=		Sound Blanket + Fiberglass (Sizes 024-070)																				
				E		=		Sound Blanket + IAQ - Closed Cell Foam (Sizes 024-070)																				
				F		=		Sound Blanket + Sound Package - Dual Layer Fiberglass (Sizes 024-070)																				
Water Coil - Indoor Coil		18		Y		=		None																				
				W		=		Waterside Economizer																				
				R		=		Hydronic Heat																				
Dehumidification		19		Y		=		None																				
				R		=		Hot Gas Reheat (WSMV and WSSV Sizes 015-070, WSTV)																				
				S		=		Simplified Dehumidification																				
Transformer		20		1		=		50VA Transformer																				
				2		=		75VA Transformer																				
Options		21-22		YY		=		None																				
				0A		=		Freeze Fault																				
				0C		=		Water Pressure Differential Switch (N/A for WSCV & WSMV Sizes 007-012)																				
				0F		=		Freeze Fault + Water Pressure Differential Switch (N/A for WSCV & WSMV Sizes 007-012)																				
Filter Racks & Filter		23		A		=		1" Rail - 1" Disposable Filter																				
				D		=		2" Rack - 2" MERV 8 Filter																				
				H		=		4" Rack - 4" MERV 13 Filter																				
				Y		=		None																				
Water Flow Options		24		Y		=		None																				
				A		=		Isolation Valve (NO) (N/A for WSCV & WSMV Sizes 007-012)																				
				B		=		Isolation Valve (NC) (N/A for WSCV & WSMV Sizes 007-012)																				
				C		=		Head Pressure Control - Refrigerant Tap																				

1	2-3	4	5-7	8	9	10	11-12	13	14	15	16	17	18	19	20	21-22	23	24	25	26	27	28	29	30	31	32	33	34
W	SC	V	007	E	1	F	LT	C	M	T	P	A	Y	Y	1	YY	A	Y	Y	Y	Y	Y	S	S	Y	Y	Y	L

Category	Code Option	Code	=	Description	
Piping Package	25	Y	=	None	WSSV & WSTV Models Only
		A	=	Auto Flow Control - 1.5 GPM	
		B	=	Auto Flow Control - 2.0 GPM	
		C	=	Auto Flow Control - 2.5 GPM	
		D	=	Auto Flow Control - 3.0 GPM	
		E	=	Auto Flow Control - 4.0 GPM	
		F	=	Auto Flow Control - 4.5 GPM	
		G	=	Auto Flow Control - 5.0 GPM	
		H	=	Auto Flow Control - 6.0 GPM	
		J	=	Auto Flow Control - 7.0 GPM	
		K	=	Auto Flow Control - 8.0 GPM	
		L	=	Auto Flow Control - 9.0 GPM	
		M	=	Auto Flow Control - 10.0 GPM	
		N	=	Auto Flow Control - 11.0 GPM	
P	=	Auto Flow Control - 12.0 GPM			
Q	=	Auto Flow Control - 13.0 GPM			
S	=	Auto Flow Control - 15.0 GPM			
Electric Heat Size	26	Y	=	None	
		F	=	Electric Heat Control Harness - 24V Signal (Field Installed Duct Heater by Others)	
Electric Heat Control (Board Configuration)	27	Y	=	None	
		B	=	Boilerless Electric Heat	
		P	=	Primary Electric Heat (No Heat Pump Heating)	
		S	=	Supplemental Heat	
Cabinet Color	28	Y	=	Galvanized	WSMV, WSSV & WSTV Models Only
		B	=	Textured Charcoal Bronze	
		W	=	Off White	
		S	=	Antique Ivory	
		D	=	Cupola White	
		V	=	Soft Grey	
K	=	Putty Beige			
Standard or Special	29	S	=	Standard	
		X	=	Special	
Drain Pan Material	30	S	=	Stainless Steel Drain Pan	
Electrical Options	31	Y	=	None	
		D	=	Non-Fused Disconnect Switch	
Corrosion Protection	32	Y	=	None	
		C	=	Corrosion Protection	
Future Use	33	Y	=	None	

1	2-3	4	5-7	8	9	10	11-12	13	14	15	16	17	18	19	20	21-22	23	24	25	26	27	28	29	30	31	32	33	34
W	SC	V	007	E	1	F	LT	C	M	T	P	A	Y	Y	1	YY	A	Y	Y	Y	Y	Y	S	S	Y	Y	Y	L

Category	Code Option	Code	=	Description
Extended Warranty	34	Y	=	None
		V	=	1 Year Extended Compressor Only Parts Warranty
		W	=	1 Year Extended Refrigerant Circuit Parts Warranty
		M	=	1 Year Extended Compressor Only Parts Warranty with 1st Year Labor Allowance
		N	=	1 Year Extended Refrigerant Circuit Parts Warranty with 1st Year Labor Allowance
		S	=	1 Year Extended Complete Unit Parts Warranty with 1st Year Labor Allowance
		E	=	1 Year Extended Complete Unit Parts Warranty
		C	=	4 Year Extended Compressor Only Parts Warranty
		R	=	4 Year Extended Refrigerant Circuit Parts Warranty
		P	=	4 Year Extended Complete Unit Parts Warranty
		F	=	4 Year Extended Compressor Only Parts Warranty with 1st Year Labor Allowance
		H	=	4 Year Extended Refrigerant Circuit Parts Warranty with 1st Year Labor Allowance
		J	=	4 Year Extended Complete Unit Parts Warranty with 1st Year Labor Allowance
		L	=	First Year Labor Allowance
T	=	4 Year Extended Complete Unit Parts Warranty with 5 Year Labor Allowance		

Installation

⚠ WARNING

The installer must determine and follow all applicable local and national codes and regulations. This equipment presents hazards of electricity, rotating parts, sharp edges, heat and weight. Failure to read and follow these instructions can result in property damage, personal injury, or death. This equipment must be installed by experienced, trained personnel only.

⚠ WARNING

This appliance shall be installed in accordance with national wiring regulations (national electric code, Canadian electric code).

Receiving and Handling

⚠ CAUTION

Sharp edges can cause minor injury. Avoid contact with them.

Carefully check equipment against the bill of lading to ensure all items have been received. Before unloading any unit, check the nameplate to make sure the voltage complies with the power supply available.

Inspect all units for damage upon arrival. If a unit has become dirty during shipment, carefully clean it prior to completing the inspection. Daikin Applied is not responsible for physical damage after the unit leaves the factory unless the contract with Daikin Applied states otherwise.

NOTICE

All units should be carefully inspected for damage when received. Report all loss or shipping damage using a claim form supplied by Daikin Applied.

VISIBLE LOSS OR DAMAGE: Any external evidence of loss or damage must be noted on the freight bill or carrier's receipt, and signed by the carrier's agent. Failure to adequately describe such external evidence of loss or damage may result in the carrier's refusal to honor a damage claim.

CONCEALED LOSS OR DAMAGE: Concealed loss or damage means loss or damage which does not become apparent until the unit has been unpacked or unwrapped. The contents may be damaged in transit due to rough handling even though the exterior may not show damages. When the damage is discovered, make a written request for inspection by the carrier's agent within **five (5) days** of the delivery date and file a claim with the form provided by Daikin Applied. Refer to the Daikin Applied Freight Policy for further information.

For storing, each carton is marked with "up" arrows.

The unit should be shipped or stored in the normal up-right position. Do not operate the machine until it has been in the normal upright position for at least 24 hours.

Temporary storage at the job site must be indoor, completely sheltered from rain, snow, etc. Units should not be installed in environments that fall below freezing or exceed 140°F (60°C) ambient.

The contractor shall cover the units to protect the machines during finishing of the building. This is critical while spraying fireproofing material on bar joists, sandblasting, spray painting and plastering. If plastic film is not available, the shipping carton may be modified to cover the units during construction.

Operating Limits

This equipment is designed for indoor installation only. Sheltered locations such as attics, garages, etc., generally will not provide sufficient protection against extremes in temperature and/or humidity, and equipment performance, reliability, and service life may be adversely affected.

NOTICE

Altitude Limits: Maximum applied altitude not to exceed 3,000 meters/ 9,843 feet.

Initial Unit Start-Up Temperature Range

NOTICE

This is not for continuous operation. It is assumed that such a start-up is for the purpose of bringing the building space up to occupancy temperature.

Standard range units

Units are designed to start in an ambient of 50°F (10°C), with entering air at 50°F (10°C), with entering water at 70°F (21°C), with both air and water at the flow rates used in the ISO 13256-1 rating test, for initial start-up in winter.

Extended range units

Extended range heat pump conditioners are designed to start in an ambient of 40°F (5°C), with entering air at 40°F (5°C), with entering water at 40°F (5°C), with both air and water at the flow rates used in the ISO 13256-1 rating test, for initial start-up in winter.

Table 1: Air Limits in °F (°C)

Air Limits	Standard Range Units		Extended Range (Geothermal) Units	
	Cooling (DB/WB)	Heating	Cooling (DB/WB)	Heating
Minimum Ambient Air ¹	50°F (10°C)	50°F (10°C)	40°F (4°C)	40°F (4°C)
Maximum Ambient Air ²	100°F/77°F (38°C/25°C)	85°F (29°C)	100°F/77°F (38°C/25°C)	85°F (29°C)
Minimum Entering Air ¹	65°F/55°F (18°C/13°C)	50°F (10°C)	65°F/55°F (18°C/13°C)	50°F (10°C)
Common Design Entering Air	75°F/63°F (24°C/17°C)	70°F (21°C)	75°F/63°F (24°C/17°C)	70°F (21°C)
Maximum Entering Air ²	85°F/71°F (29°C/22°C)	80°F (27°C)	85°F/71°F (29°C/22°C)	80°F (27°C)

¹ Maximum and minimum values may not be combined. If one value is at maximum or minimum, the other conditions may not exceed the normal condition for standard units. Extended range units may combine any two maximum conditions, but not more than two, with all other conditions being normal conditions.

² This is not for continuous operation. It is assumed that such a start-up is for the purpose of bringing the building space up to occupancy temperature.

Table 2: Fluid Limits

Fluid Limits	Standard Range Units		Extended Range (Geothermal) Units	
	Cooling	Heating	Cooling	Heating
Minimum Entering Fluid	55°F (13°C)	55°F (13°C)	30°F (-1°C)	25°F (-4°C)
Common Design Entering Fluid	85-90°F (29-32°C)	70°F (21°C)	90°F (32°C)	35-60°F (1.5-16°C)
Maximum Entering Fluid	120°F (49°C)	90°F (32°C)	120°F (49°C)	90°F (32°C)
Minimum GPM/Ton	2.0			
Nominal GPM/Ton	3.0			
Maximum GPM/Ton	4.0			

Glycol Solutions

The use of glycol may impact system performance depending on its concentration and should be considered during initial system design. When glycol is added to the water system for freeze protection, recognize that the refrigerant suction pressure will be lower, capacity will be less, and water side pressure drop will be higher. The reduction in performance depends upon the glycol concentration and temperature.

 CAUTION
Do not use an automotive-grade antifreeze. Industrial grade glycols must be used. Automotive antifreeze contains inhibitors which will cause plating on the copper tubes within the chiller evaporator. The type and handling of glycol used must be consistent with local codes.

Table 3: Antifreeze Correction Factors

Ethylene Glycol					
	10%	20%	30%	40%	50%
Cooling Capacity	0.995	0.992	0.987	0.983	0.979
Heating Capacity	0.991	0.982	0.977	0.969	0.961
Pressure Drop	1.07	1.13	1.18	1.26	1.28
Propylene Glycol					
	10%	20%	30%	40%	50%
Cooling Capacity	0.99	0.98	0.97	0.96	0.95
Heating Capacity	0.987	0.975	0.962	0.942	0.93
Pressure Drop	1.07	1.15	1.25	1.37	1.42
Ethanol					
	10%	20%	30%	40%	50%
Cooling Capacity	0.991	0.951	-	-	-
Heating Capacity	0.995	0.96	-	-	-
Pressure Drop	1.035	0.96	-	-	-
Methanol					
	10%	20%	30%	40%	50%
Cooling Capacity	0.998	0.972	-	-	-
Heating Capacity	0.995	0.97	-	-	-
Pressure Drop	1.023	1.057	-	-	-

NOTE: Higher percentage mixtures of ethanol and methanol are not recommended due to increased flammability.

Pre-Installation

- To prevent damage, do not operate this equipment for supplementary ventilation, heating and cooling during the construction period.
- Inspect the carton for any specific tagging numbers indicated by the factory per a request from the installing contractor.

NOTICE
Check the unit data plate for correct voltage (See Table 14), phase and capacity with the plans before installing the equipment. Also, make sure all electrical ground connections are made in accordance with local code.

- If 460/60/3 unit includes a constant CFM ECM, verify that a 4-wire power supply is provided with a neutral wire to provide 265 volt electrical to the fan motor.
- Check the unit size against the plans to verify that the unit is being installed in the correct location.
- Before installation, check the available ceiling height versus the height of the unit.
- Note the location and routing of water piping, condensate drain piping, and electrical wiring. The locations of these items are clearly marked on submittal drawings. The installing contractor will find it beneficial to confer with piping, sheet metal, and electrical foremen before installing any unit.
- Remove shipping brackets securing unit to skid.
- Remove all shipping blocks from the fan wheel if present. See Figure 1.

Figure 1: Remove Foam Shipping Block From Fan Housing

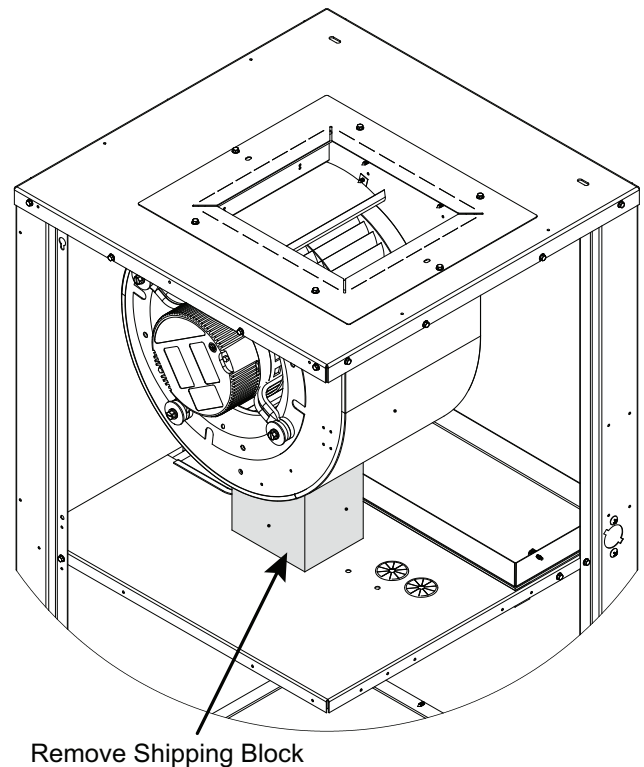

Unit Location and Clearances

⚠ WARNING

Clearance should be maintained to meet local and national code requirements.

- Locate the unit in an area that allows for easy removal of the filter and access panels. Allow clearance around the heat pump for easy removal of the entire unit (if necessary), and to perform routine maintenance, or troubleshooting. Provide sufficient room to make water, electrical and duct connections. See [Figure 2](#).

- Unit condensate drains are not internally trapped. External trap is required for vertical units. Allow adequate room around the unit for condensate piping.
- If the unit is installed in a confined space, such as a closet, provisions must be made for return air to freely enter the face of the unit's air coil.
- It is recommended that the unit be installed level on top of a vibration absorbing pad. The isolation pad should be the same size or larger than the base of the unit to minimize sound and vibration transmission from the unit to the building structure. See [Figure 3](#).

Figure 2: Recommended Clearances for Service Access

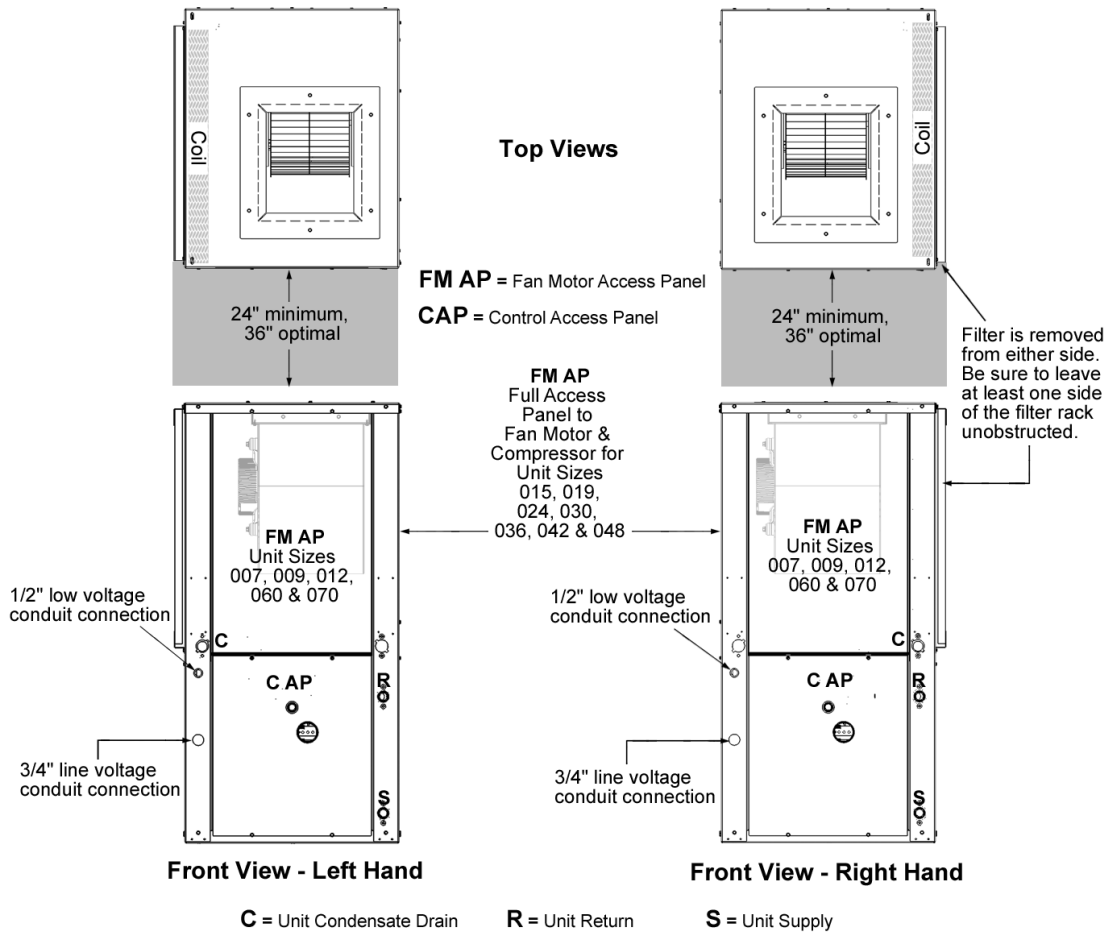
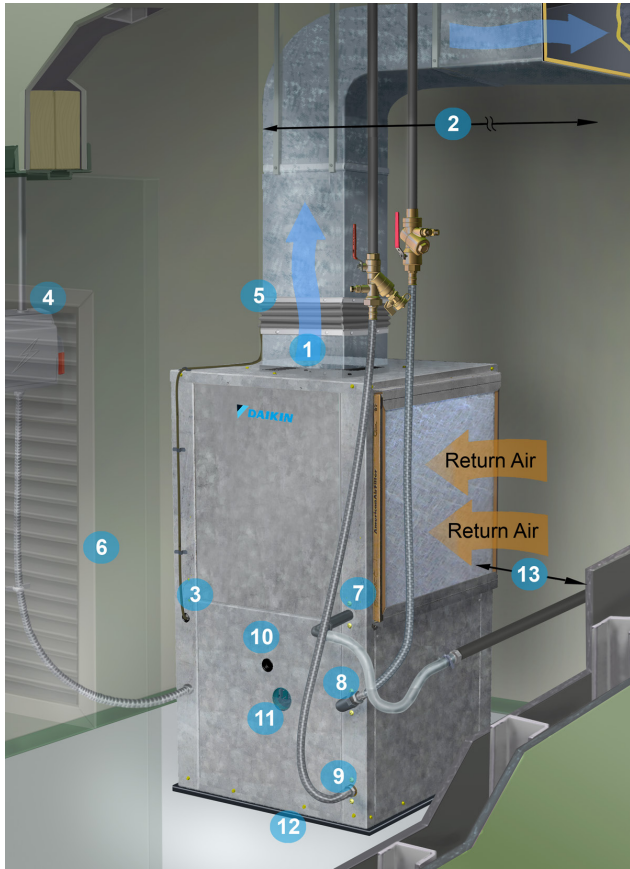

Figure 3: Vertical Unit - Typical Installation in Small Mechanical Room or Closet



No.	Description
1	Discharge air
2	Acoustic thermal duct lining - 10 feet
3	Low voltage wiring to unit control box
4	Line voltage disconnect
5	Flexible duct collar
6	Louvered closet door
7	Condensate drain (field-supplied trap)
8	Flexible, braided, stainless steel return hose with flow controller/ball valve with port
9	Flexible, braided, stainless steel supply hose with Y-strainer/ball valve with port
10	Access to unit control box
11	LED annunciator lights sight glass to view unit operation status and faults
12	Full vibration isolation pad between unit and floor
13	Minimum distance between return air (filter) and wall for non-ducted return applications: Size 007-012 – 5 in. Size 015-024 – 5 in. Size 030-036 – 6 in. Size 042-048 – 8 in. Size 060-070 – 10 in.

Water Piping

WARNING

Polyolester Oil, commonly known as POE oil is a synthetic oil used in many refrigeration systems, and may be present in this Daikin Applied product. POE oil, if ever in contact with PVC/CPVC, will coat the inside wall of PVC/CPVC pipe causing environmental stress fractures. Although there is no PVC/CPVC piping in this product, please keep this in mind when selecting piping materials for your application, as system failure and property damage could result. Refer to the pipe manufacturer's recommendations to determine suitable applications of the pipe.

Pre-Installation Considerations

All units should be connected to supply and return piping in a two-pipe reverse return configuration. A reverse return system is inherently self-balancing and requires only trim balancing where multiple quantities of units with different flow and pressure drop characteristics exist in the same loop. Refer to Figure 6.

A direct return system may also work acceptably, but proper water flow balancing is more difficult to achieve and maintain.

The piping can be steel or copper.

Supply and return runouts usually join the unit via short lengths of high pressure flexible hose which are sound and vibration isolators for both unit operating noise and hydraulic pumping noise.

- One end of the hose should have a swivel fitting to facilitate removal for service.

NOTICE

Hard piping is not recommended since no vibration or noise attenuation can be accomplished.

Figure 4: Flexible Hose Kit #7

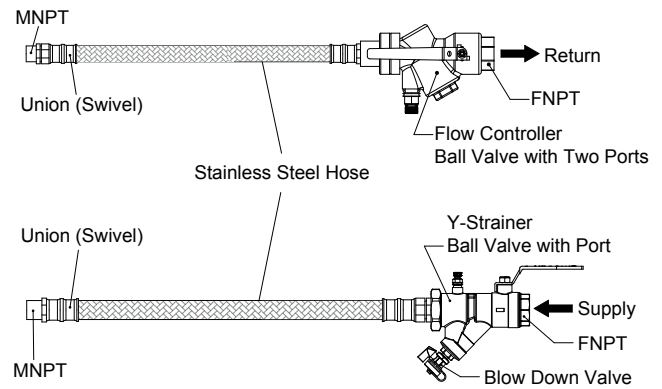

NOTICE

Do not over-torque fittings. The maximum torque without damage to fittings is 30 foot pounds. If a torque wrench is not available, use as a rule of thumb, finger tight plus one quarter turn.

1. No unit should be connected to the supply and return piping until the water system has been cleaned and flushed completely, see "Cleaning & Flushing System" on page 14. After the cleaning and flushing has taken place, the initial connection should have all valves wide open in preparation for water system flushing.

- Supply and return shutoff valves are required at each unit. The return valve can be used for balancing. When used it should have a "memory stop" so that it can be closed off, and reopened to the proper position for the required flow.

NOTICE

Improper trapping can lead to several problems. If the trap is too tall, negative pressure will prevent drainage, causing condensate backup. If the trap is too short the seal will be destroyed or nonexistent, producing the same effect as a non-trapped system.

- Each water source heat pump is provided with a 3/4" FPT flush mount fitting for connection of a condensate drain. Copper or steel condensate piping should be insulated to prevent sweating. Do not locate any point in the drain system above the condensate drain connection of any unit.

NOTICE

It may be necessary to manually fill the trap at system startup, or to run the unit for sufficient time to build a condensate seal. The condensate trap and condensate piping drainage should be free of any foreign debris. Debris can prevent proper drainage and unit operation and result in condensate buildup.

Condensate Drain

A field provided condensate trap must be installed on each water source heat pump. Condensate removal piping must be pitched away from the unit not less than 1/4" per foot. A field installed air vent may be required after the condensate trap to prevent air pockets from forming and to allow the condensate to drain away from the unit. The vent should extend at least 1-1/4" above the unit condensate fitting. The vent can also act as a clean out if the trap becomes clogged. To avoid having waste gases entering the building, the condensate drain should not be directly piped to a drain/waste/vent stack, etc. Check the local building or plumbing codes for the proper condensate requirements in your area.

Figure 5: Unit Condensate Drain Pipe Trap Detail

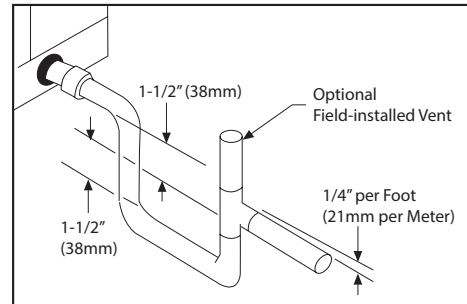
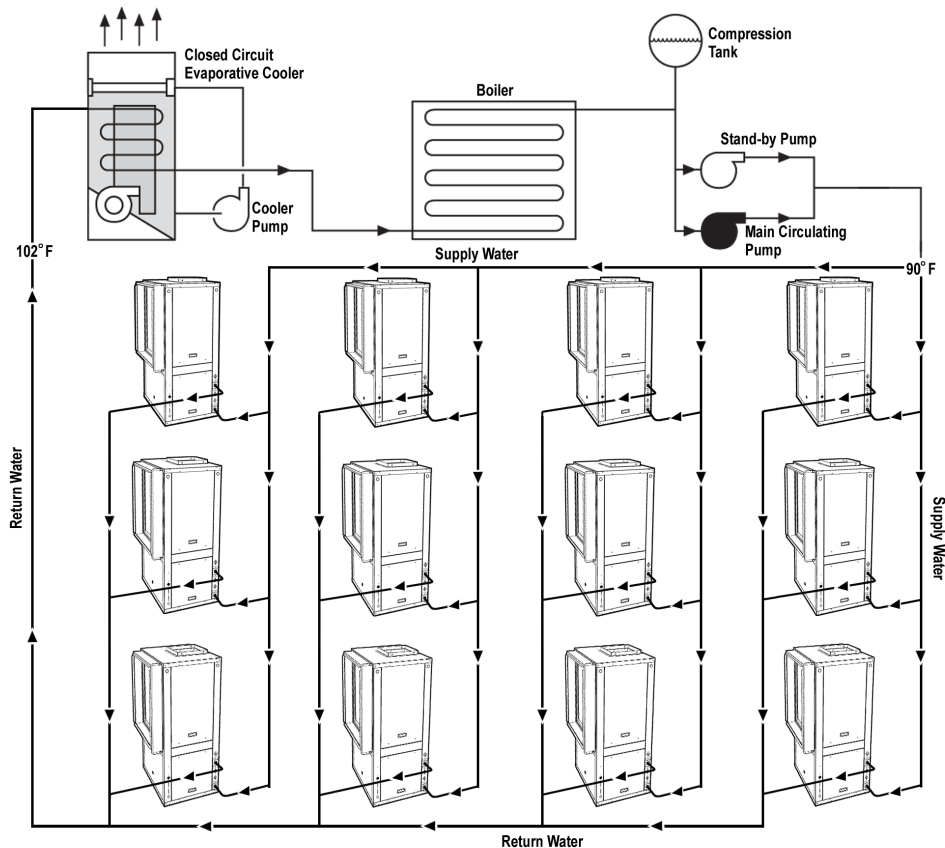

Figure 6: Example of a Reverse Return Piping System



Water System Quality

The cleaning, flushing and chemical treatment of a water source heat pump system is fundamental to efficient operation and the life expectancy of the system.

Potential system problems produced by the use of water fall into three general categories:

1. Scale formation – Mineral deposits which result from the crystallization and precipitation of dissolved salts in the water. The deposits form an insulating barrier, reducing the heat transfer rate and impeding the circulation of fluids due to increased pressure drop.
2. Corrosion – Decomposition of the metal caused by absorption of gases from the air. Corrosion may occur in any metal component of the system.
3. Organic growths – Slime and algae which form under certain environmental conditions, and can reduce the heat transfer rate by forming an insulating coating or can promote corrosion by pitting.

The system water should be evaluated for degrees of impurity, with testing available from independent testing labs, health departments or state agencies. Refer to [Table 4 on page 15](#).

NOTICE

Units with a brazed plate heat exchanger must include a field provided and installed strainer with a minimum of a 20-mesh rating in the supply piping to prevent heat exchanger clogging. For units with a coaxial heat exchanger, the same 20-mesh strainer is recommended.

Cleaning & Flushing System

1. Prior to first operation of any conditioner, the water circulating system must be cleaned and flushed of all construction dirt and debris.

If the conditioners are equipped with water shutoff valves, either electric or pressure operated, the supply and return runouts must be connected together at each conditioner location. This will prevent the introduction of dirt into the unit. See [Figure 7](#).
2. Fill the system at the city water makeup connection with all air vents open. After filling, close all air vents.

The contractor should start main circulator with the pressure reducing valve open. Check vents in sequence to bleed off any trapped air, ensuring circulation through all components of the system. Power to the heat rejector unit should be off, and the supplementary heat control set at 80°F (27°C). While circulating water, the contractor should check and repair any leaks in the piping. Drains at the lowest point(s) in the system should be opened for initial flush and blowdown, making sure city water fill valves are set to make up water at the same rate. Check the pressure gauge at pump suction and manually adjust the makeup to hold the same positive steady pressure both before and after opening the drain valves. Flush should continue for at least two hours, or longer if required, to see clear, clean drain water.

3. Shut off supplemental heater and circulator pump and open all drains and vents to completely drain down the system. Short circuited supply and return runouts should now be connected to the conditioner supply and return connections. Do not use sealers at the swivel flare connections of hoses. Trisodium phosphate was formerly recommended as a cleaning agent during flushing. However, many states and localities ban the introduction of phosphates into their sewage systems. The current recommendation is to simply flush longer with warm 80°F (27°C) water.
4. Refill the system with clean water. Test the water using litmus paper for acidity, and treat as required to leave the water slightly alkaline (pH 7.5 to 8.5). The specified percentage of antifreeze may also be added at this time. [See Table 3](#). Use commercial grade antifreeze designed for HVAC systems only. Do not use automotive grade antifreeze.

Once the system has been filled with clean water and antifreeze (if used), precautions should be taken to protect the system from dirty water conditions. Dirty water will result in system wide degradation of performance and solids may clog valves, strainers, flow regulators, etc. Additionally, the heat exchanger may become clogged which reduces compressor service life or causes premature failure.

5. Set the loop water controller heat add setpoint to 70°F (21°C) and the heat rejection setpoint to 85°F (29°C). Supply power to all motors and start the circulating pumps. After full flow has been established through all components including the heat rejector (regardless of season) and air vented and loop temperatures stabilized, each of the conditioners will be ready for check, test and start-up, air balancing, and water balancing.

Table 4: Water Quality Conditions and Applications

Potential Problem	Chemical(s) or Condition	Range for Copper Heat Exchangers	Range of Cupronickel Heat Exchanger
Scaling	Calcium & Magnesium Carbonate	Less than 350 ppm	Less than 350 ppm
	pH Range	7 – 9	5 – 9
Corrosion	Total Dissolved Solids	Less than 1000 ppm	Less than 1500 ppm
	Ammonia, Ammonium Hydroxide	Less than 0.5 ppm	Less than 0.5 ppm
	Ammonium Chloride, Ammonium Nitrate	Less than 0.5 ppm	Less than 0.5 ppm
	Calcium Chloride/ Sodium Chloride	Less than 125 ppm	Less than 125 ppm - Note 4
	Chlorine	Less than 0.5 ppm	Less than 0.5 ppm
	Hydrogen Sulfide	None Allowed	None Allowed
Biological Growth	Iron Bacteria	None Allowed	None Allowed
	Iron Oxide	Less than 1 ppm	Less than 1 ppm
Erosion	Suspended Solids	Less than 10 ppm	Less than 10 ppm
	Water Velocity	Less than 8 ft./s	Less than 12 ft./s

- NOTE 1:** Water hardness in ppm is equivalent to hardness in mg/L.
- NOTE 2:** Grains/gallon = ppm divided by 17.1.
- NOTE 3:** Copper and cupronickel heat exchangers are not recommended for pool applications for water outside the range of the table. Secondary heat exchangers are required for applications not meeting the requirements shown above.
- NOTE 4:** Salt water applications (approx. 25,000 ppm) require secondary heat exchangers due to copper piping between the heat exchanger and the unit fittings.

Figure 7: Supply and Return Runouts Connected Together

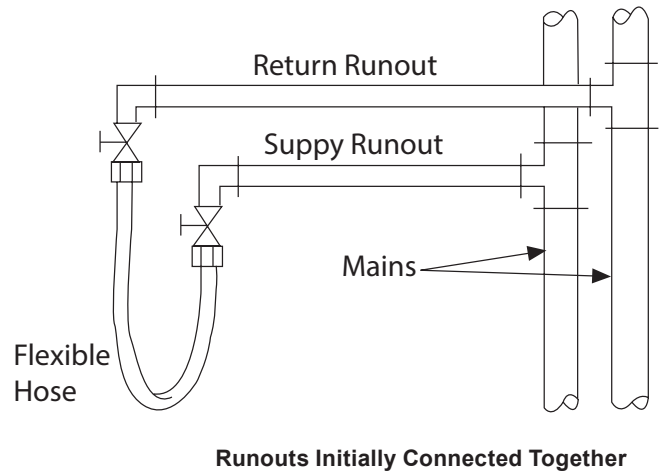
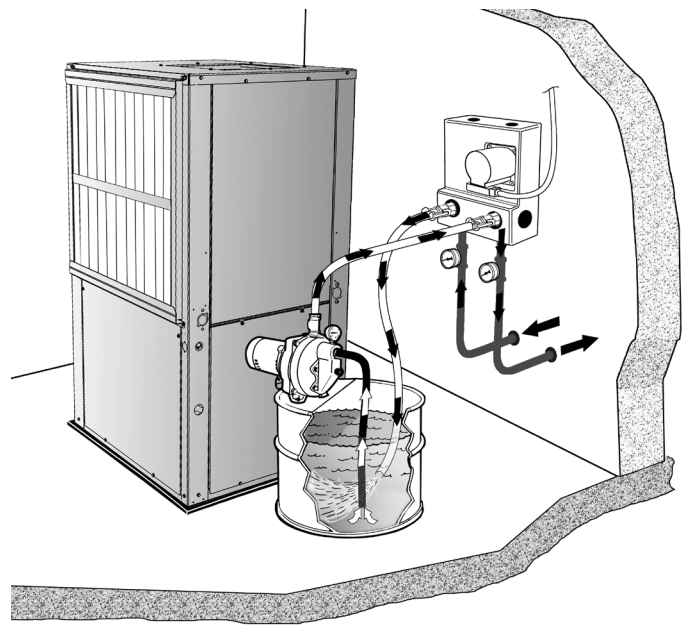
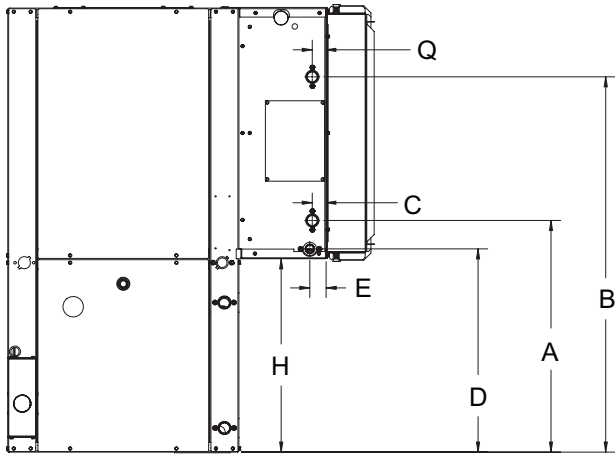

Figure 8: Flushing the Loop



Piping Considerations for Units With Waterside Economizer / Hydronic Heating

Figure 9: Waterside Economizer / Hydronic Heating Unit Descriptions



Right Hand Unit

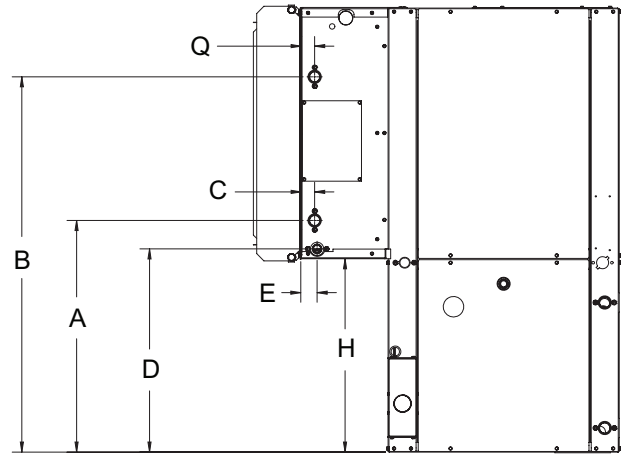

Left Hand Unit

NOTE: The economizer package incorporates its own drain pan to collect condensate from the coil when utilized for economizer cooling operation. This pan **MUST** be independently trapped and can be piped into the drain line for the heat pump.

Figure 10: Waterside Economizer / Hydronic Heating Piping Locations and Dimensions

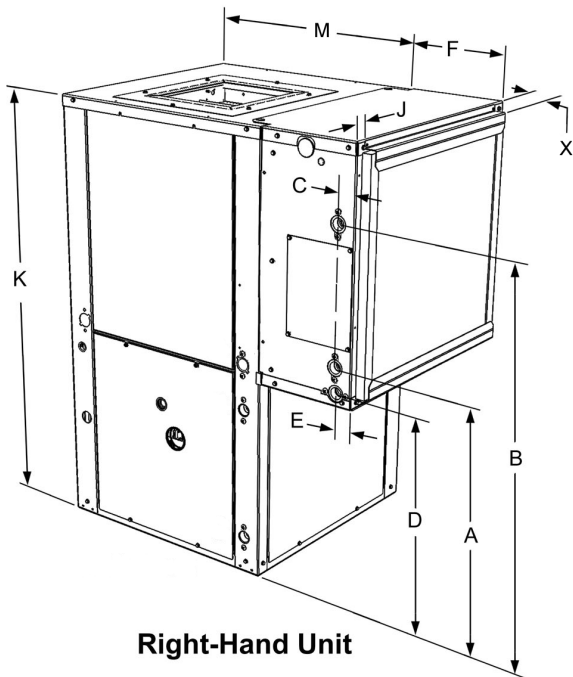

Right-Hand Unit

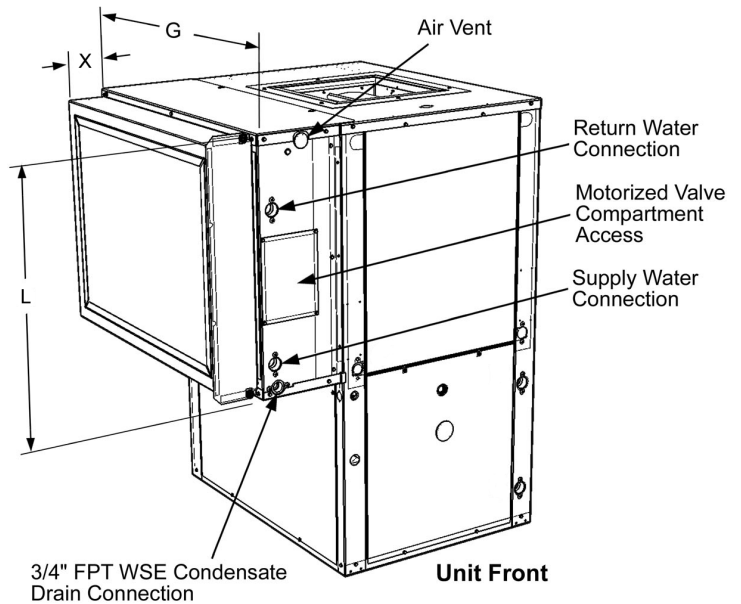

Left-Hand Unit

Table 5: Unit Waterside Economizer/Hydronic Heating Connection Dimensions for Figure 9 and Figure 10

Unit Model	Unit Size	Waterside Economizer / Hydronic Heating Connections					3/4" FPT Condensate Drain	
		Connection Size (FPT)	Supply		Return			
			A	C	B	Q	D	E
WSCV	007, 009, 012	1/2"	16.23	1.69	24.44	1.69	13.93	1.69
	015, 019	1/2"	21.54	1.69	31.19	1.69	19.55	1.69
	024, 030	3/4"	23.42	1.81	34.85	1.81	20.05	1.69
	036, 042	3/4"	27.3	1.8	38.7	1.81	21.05	1.69
	048, 060, 070	1"	24.0	1.43	38.88	1.43	21.05	1.69
WSMV	007, 009, 012	1/2"	15.62	1.69	27.57	1.69	13.93	1.69
	015, 019	3/4"	23.42	1.81	34.85	1.81	20.05	1.69
	024, 030	3/4"	27.3	1.8	38.7	1.81	21.05	1.69
	036,042	1"	24.0	1.43	38.88	1.43	21.05	1.69
	048, 060	1"	33.81	1.66	45.24	1.66	22.05	1.69
WSSV	007, 009, 012	1/2"	21.54	1.69	31.19	1.69	19.55	1.69
	015, 019	1"	27.3	1.8	38.7	1.81	21.05	1.69
	024, 030	1"	24.0	1.43	38.88	1.43	21.05	1.69
	036, 042	1"	33.81	1.66	45.24	1.66	22.05	1.69
	048, 060, 070	1"	36.81	1.66	48.24	1.66	22.05	1.69
WSTV	024, 030	1"	24	1.43	38.88	1.43	21.05	1.69
	036, 042	1"	33.81	1.66	45.24	1.66	22.05	1.69
	048, 060, 070	1"	36.81	1.66	48.24	1.66	22.05	1.69

NOTE: All dimensions within ± 0.10 inches (2.5 mm).

Table 6: Unit Cabinet With Waterside Economizer / Hydronic Heating Dimensions for Figure 9, Figure 10, and Figure 11

Unit Model	Unit Size	Waterside Economizer/Hydronic Heating Overall Cabinet Section			H	Unit Height	Unit Width
		Width	Depth	Height			
		F	G	L		K	M
WSCV	007, 009, 012	9.0	19.0	12.16	13.5	24.0	19.0
	015, 019	9.0	21.5	15.54	18.5	34.0	21.5
	024, 030	9.0	21.5	21.04	19.0	38.0	21.5
	036, 042	9.0	26.0	24.04	20.0	44.0	26.0
	048, 060, 070	9.0	32.5	26.04	20.0	46.0	32.5
WSMV	007, 009, 012	9.0	19.0	17.42	12.9	30.25	19.0
	015, 019	9.0	21.5	21.04	19.0	38.0	21.5
	024, 030	9.0	26.0	24.04	20.0	44.0	26.0
	036,042	9.0	32.5	26.04	20.0	46.0	32.5
	048, 060	9.0	32.5	29.54	21.0	50.5	32.5
WSSV	007, 009, 012	9.0	21.5	15.54	18.5	34.0	21.5
	015, 019	9.0	26.0	24.04	20.0	44.0	26.0
	024, 030	9.0	32.5	26.04	20.0	46.0	32.5
	036, 042	9.0	32.5	29.54	21.0	50.5	32.5
	048, 060, 070	9.0	32.5	33.04	21.0	54.0	32.5
WSTV	024, 030	9.0	32.5	26.04	20.0	46.0	32.5
	036, 042	9.0	32.5	29.54	21.0	50.5	32.5
	048, 060, 070	9.0	32.5	33.04	21.0	54.0	32.5

NOTE: All dimensions within ± 0.10 inches (2.5 mm).

Figure 11: Waterside Economizer/Hydronic Heating Overall Cabinet Section

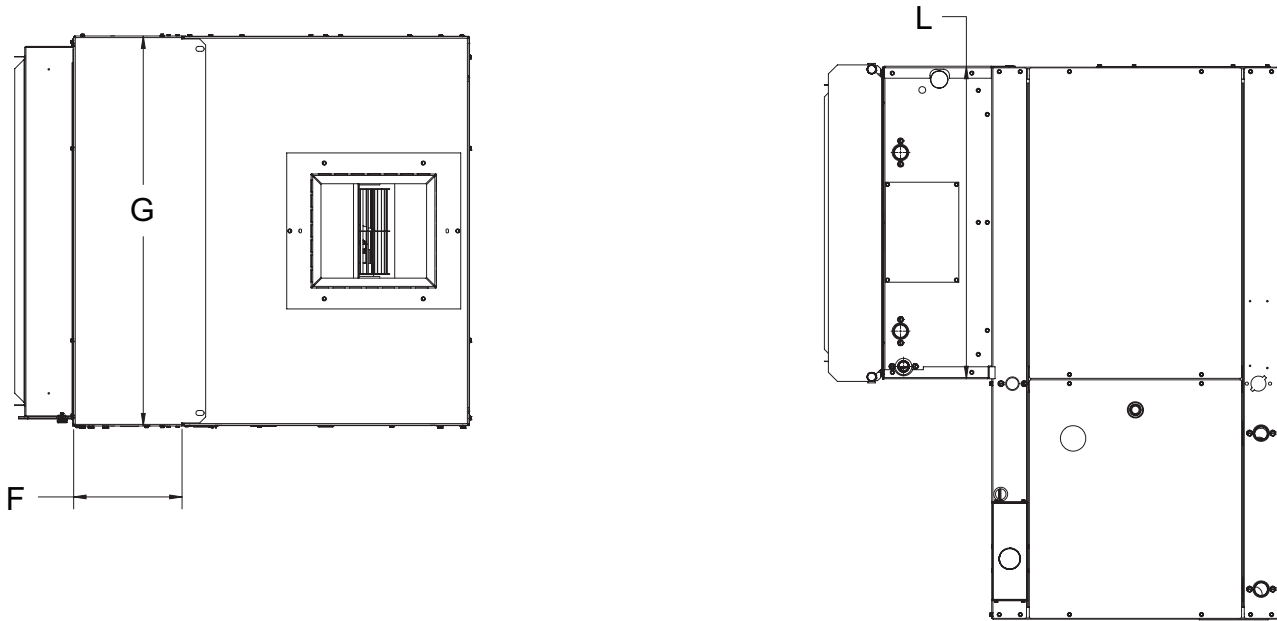

Table 7: Filter Rack Dimensions for Figure 10 and Figure 12

Unit Model	Unit Size	Filter Rack Dimensions							
		Front Offset	Frame Width	Frame Height	Depth			Duct Flange Width	Duct Flange Height
					1"	2"	4"		
J	V	W	X			Y	Z		
WSCV	007, 009, 012	0.56	17.54	10.88	1.00	2.125	4.125	15.57	9.2
	015, 019		20.04	14.24				18.07	12.57
	024, 030		20.04	19.75				18.07	18.07
	036, 042		24.54	22.75				22.57	21.07
	048, 060, 070		31.04	24.75				29.07	23.07
WSMV	007, 009, 012	0.56	17.54	16.13	1.00	2.125	4.125	15.57	14.45
	015, 019		20.04	19.75				18.07	18.07
	024, 030		24.54	22.75				22.57	21.07
	036,042		31.04	24.75				29.07	23.07
	048, 060		31.04	28.25				29.07	26.57
WSSV	007, 009, 012	0.56	20.04	14.25	1.00	2.125	4.125	18.07	12.57
	015, 019		24.54	22.75				22.57	21.07
	024, 030		31.04	24.75				29.07	23.07
	036, 042		31.04	28.25				29.07	26.57
	048, 060, 070		31.04	31.75				29.07	30.07
WSTV	024, 030	0.56	31.04	24.75	1.00	2.125	4.125	29.07	23.07
	036, 042		31.04	28.25				29.07	26.57
	048, 060, 070		31.04	31.75				29.07	30.07

NOTE: All dimensions within ± 0.10 inches (2.5 mm).

Figure 12: Filter Rack Dimensions

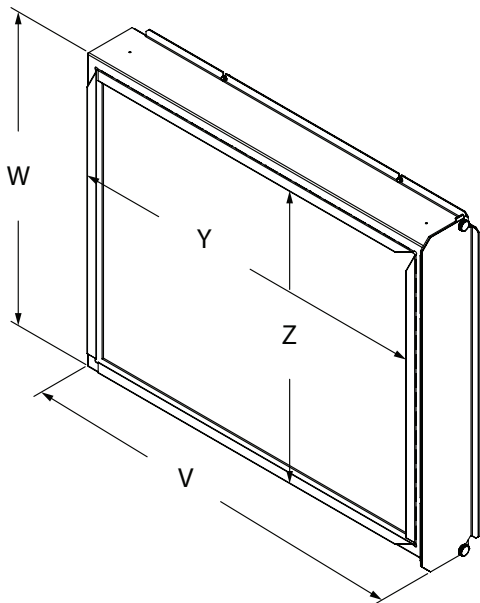
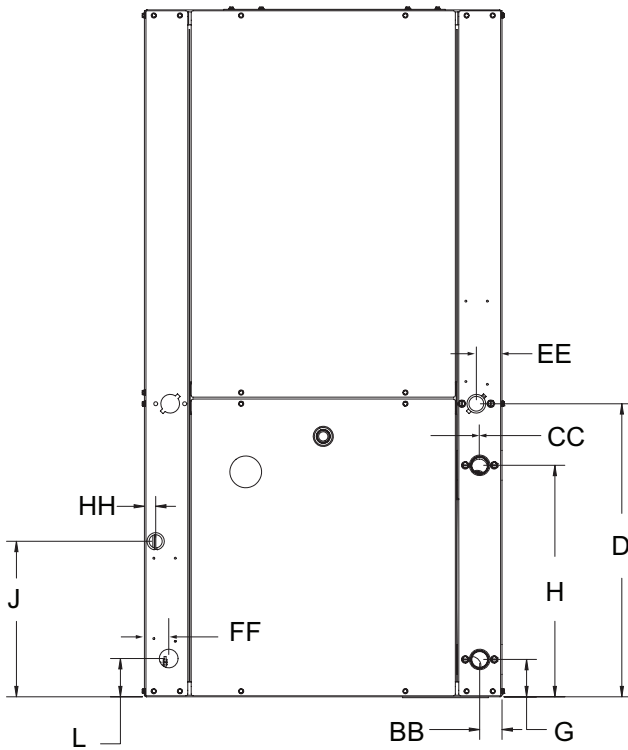
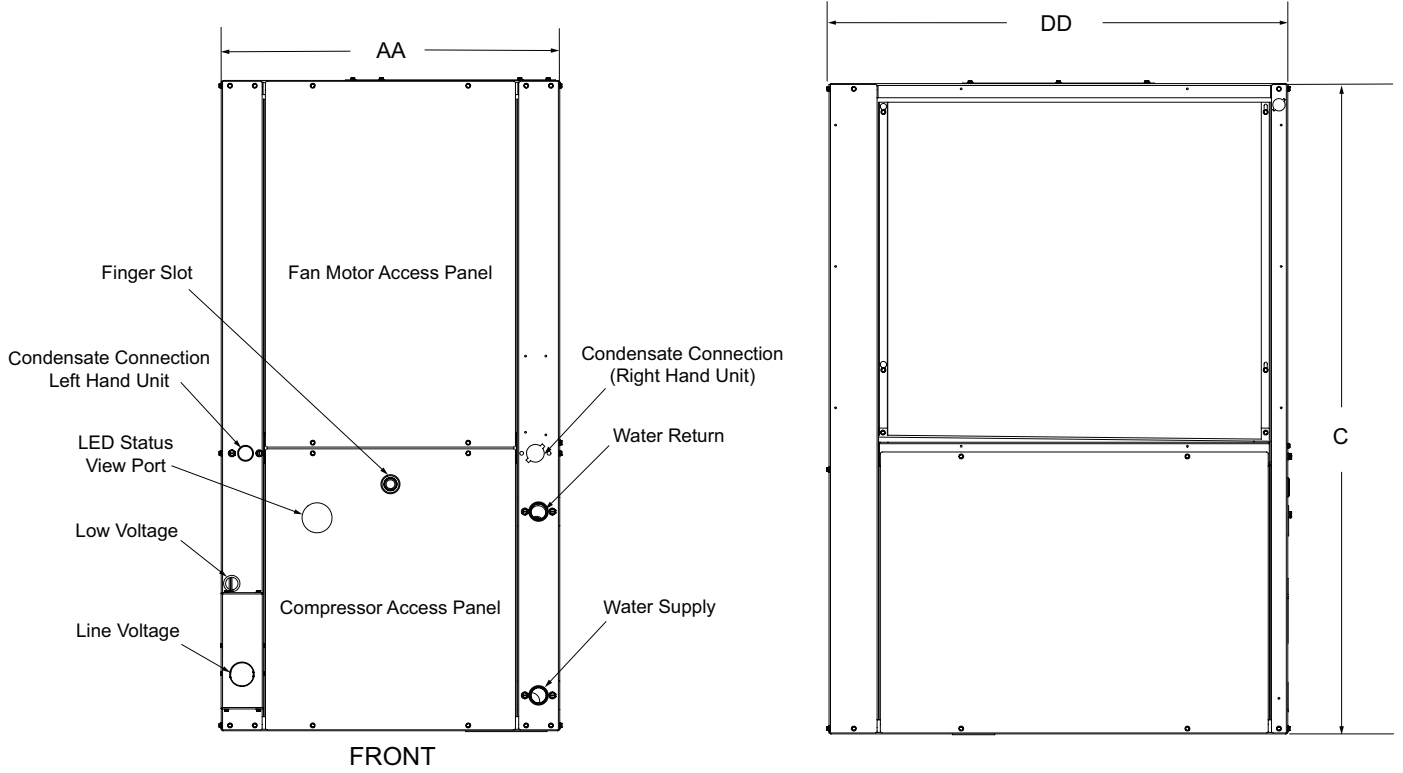
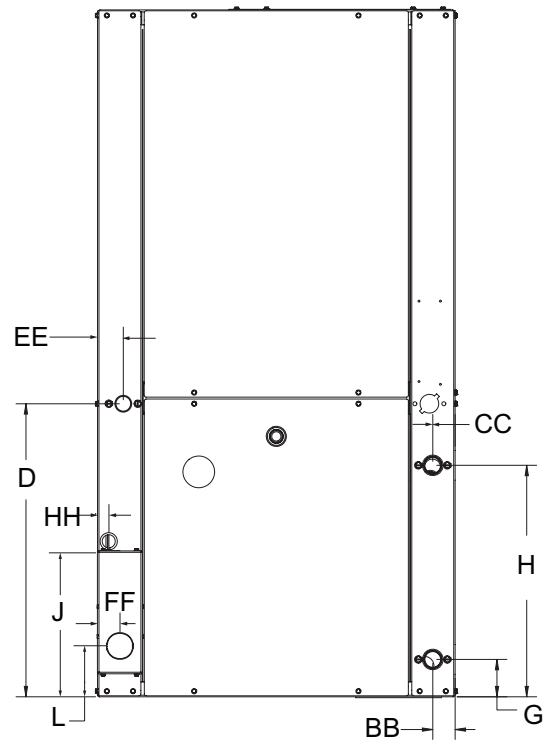

Figure 13: Piping & Electrical Connections Locations



Front View
Right Hand



Front View
Left Hand

Table 8: Unit Supply, Return, and Condensate Dimensions for Figure 13

Unit Model	Unit Size	Condenser Water Piping Dimensions					Condensate Drain 3/4" FPT	
		Connection Size (FPT)	Water Supply		Water Return		D	EE
			G	BB	H	CC		
WSCV	007, 009, 012	1/2"	1.63	2.5	10.25	1.38	12.5	1.72
	015, 019	1/2"	3.13	1.5	9.18	1.5	18.13	1.72
	024, 030	3/4"	2.5	1.5	11.25	1.5	18.63	1.72
	036, 042	3/4"	2.5	1.5	15.5	1.5	19.63	1.72
	048, 060, 070	1"	2.5	1.5	15.5	1.5	19.63	1.72
WSMV	007, 009, 012	1/2"	1.63	2.5	10.25	1.38	12.5	1.72
	015, 019	3/4"	2.5	1.5	11.25	1.5	18.63	1.72
	024, 030	3/4"	2.5	1.5	15.5	1.5	19.63	1.72
	036, 042	1"	2.5	1.5	15.5	1.5	19.63	1.72
	048, 060	1"	2.5	1.5	15.5	1.5	20.63	1.72
WSSV	007, 009, 012	1/2"	3.13	1.5	9.18	1.5	18.13	1.72
	015, 019	1"	2.5	1.5	15.5	1.5	19.63	1.72
	024, 030	1"	2.5	1.5	15.5	1.5	19.63	1.72
	036, 042	1"	2.5	1.5	15.5	1.5	20.63	1.72
	048, 060, 070	1"	2.5	1.5	15.5	1.5	20.63	1.72
WSTV	024, 030	1"	2.5	1.5	15.5	1.5	19.63	1.72
	036, 042	1"	2.5	1.5	15.5	1.5	20.63	1.72
	048, 060, 070	1"	2.5	1.5	15.5	1.5	20.63	1.72

NOTE: All dimensions within ± 0.10 inches.

Table 9: Unit Cabinet Dimensions and Electrical Connections for Figure 13

Unit Model	Unit Size	Overall Cabinet Dimensions			Electrical Connections					
		Width	Depth	Height	Line Voltage		Low Voltage		Conduit Connection Size	
		AA	DD	C	L	FF	J	HH	Line Voltage	Low Voltage
WSCV	007, 009, 012	19.0	19.0	24.0	2.56	1.63	10.41	0.75	1-1/4"	1-3/32"
	015, 019	21.5	21.5	34.0						
	024, 030	21.5	21.5	38.0						
	036, 042	21.5	26.0	44.0						
	048, 060, 070	24.0	32.5	46.0						
WSMV	007, 009, 012	19.0	19.0	30.25	2.56	1.63	10.41	0.75	1-1/4"	1-3/32"
	015, 019	21.5	21.5	38.0						
	024, 030	21.5	26.0	44.0						
	036, 042	24.0	32.5	46.0						
	048, 060	26.0	32.5	50.5						
WSSV	007, 009, 012	21.5	21.5	34.0	2.56	1.63	10.41	0.75	1-1/4"	1-3/32"
	015, 019	21.5	26.0	44.0						
	024, 030	24.0	32.5	46.0						
	036, 042	26.0	32.5	50.5						
	048, 060, 070	26.0	32.5	54.0						
WSTV	024, 030	24.0	32.5	46.0	2.56	1.63	10.41	0.75	1-1/4"	1-3/32"
	036, 042	26.0	32.5	50.5						
	048, 060, 070	26.0	32.5	54.0						

NOTE: All dimensions within ± 0.10 inches.

Ductwork and Attenuation

Discharge duct shall be used with these units. Where return air ductwork is required, the unit comes standard with a 1" thick, factory-installed disposable filter, mounted in a 2-sided filter rack. The filter can be easily removed from either side. A 2" deep 4-sided, gasketed filter rack is available as a factory-installed option to accept a 2" disposable or a 2" Merv 8 filter. Also available is a 4" deep, 4-sided, gasketed filter rack with a 2" disposable or a 4" Merv 13 filter.

All ductwork should conform to industry standards of good practice as described in ASHRAE Systems Guide.

A field supplied discharge duct system will normally consist of:

- a flexible connector at the unit
- a 90-degree elbow without vanes
- a 10 foot length of insulated duct
- and a trunk duct teeing into a branch circuit with discharge diffusers

Air Duct Connections

WARNING

If for any reason the perforated supply or return duct flanges are not required they must be bent out 90 degrees or removed.

1. Bend the perforated supply and return air duct flanges out 90 degrees with wide duct pliers.

NOTICE

It is recommended that a field supplied flexible (boot) connector is attached to the flanges to isolate vibration. See [Figure 15](#).

2. Connect the flexible boot connector and duct to the flanges. Screws used to secure supply duct should be inserted in the duct flange only.

NOTICE

Screws should not be installed through the unit cabinet. Installation of screws through the unit cabinet may contact with refrigerant piping, voiding warranty. The unit cabinet should not be cut or altered for installation of accessories.

Figure 14: Bend Duct Flanges out 90 Degrees

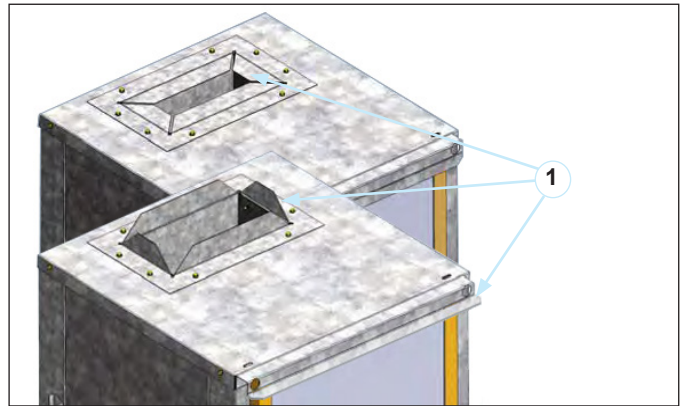
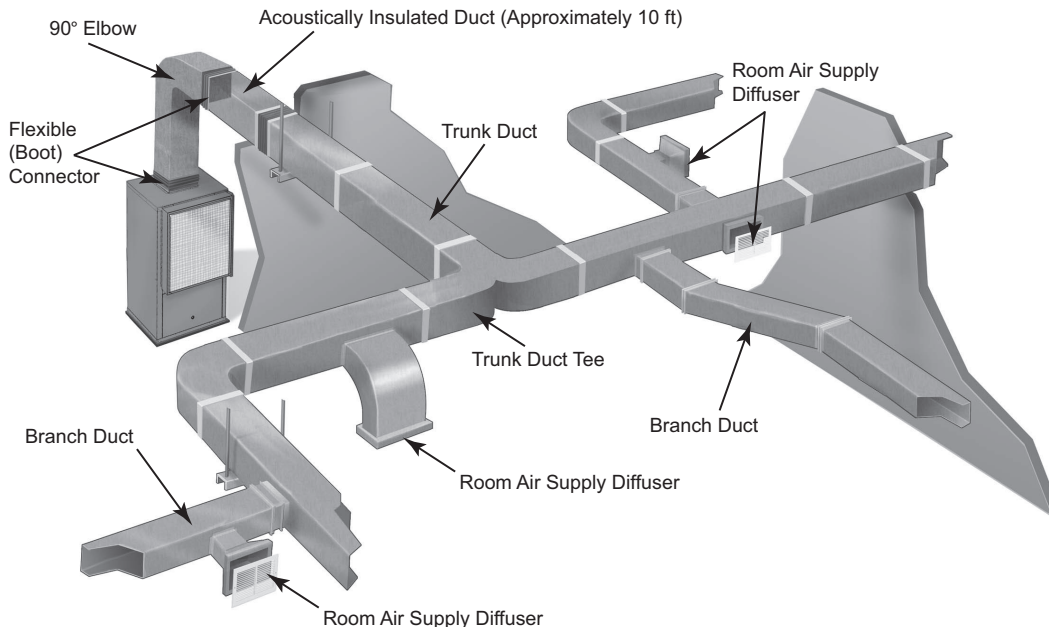

Figure 15: Typical Ducting for Vertical Unit



NOTE 1: Transformation to supply duct have maximum slope of 1" in 7".

NOTE 2: Square elbows with double thickness vanes may be substituted.

NOTE 3: Do not install ducts so that the air flow is counter to fan rotation.

NOTE 4: Transformations and units must be adequately supported so no weight is on the flexible fan connection.

Figure 16: Discharge Duct Collar Locations

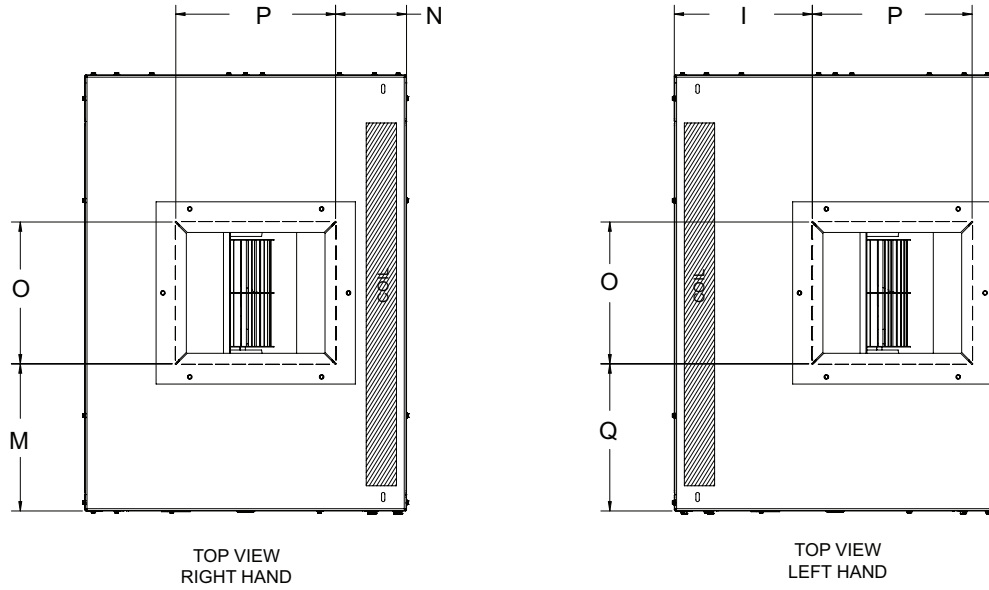

Table 10: Discharge Duct Collar Dimensions in Figure 16

Unit Model	Unit Size	Discharge Opening* - in inches									
		M		Q		O		P		N	I
		Right-Hand	Left-Hand	Right-Hand	Left-Hand	Right-Hand	Left-Hand	Right-Hand	Left-Hand	Right-Hand	Left-Hand
WSCV	007, 009, 012	4.58	4.58	9.78	9.78	5.22	5.22	8.9	4.84		
	015, 019, 024, 030	3.75	3.75	10.38	10.38	9.43	9.43	7.72	7.72		
	036	6.0	6.0	10.38	10.38	9.43	9.43	5.97	5.97		
	042	3.24	3.24	11.89	11.89	10.56	10.56	4.66	6.16		
	048	10.91	10.91	10.56	10.56	11.89	11.89	5.24	10.24		
	060, 070	9.53	9.53	13.32	13.32	13.89	13.89	4.99	7.99		
WSMV	007, 009, 012	4.58	4.58	9.78	9.78	5.22	5.22	8.9	4.84		
	015, 019	3.75	3.75	10.38	10.38	9.43	9.43	7.72	7.72		
	024, 030	6.0	6.0	10.38	10.38	9.43	9.43	5.97	5.97		
	036	11.47	11.47	9.43	9.43	10.38	10.38	6.75	10.75		
	042	10.91	10.91	10.56	10.56	11.89	11.89	5.24	10.24		
	048	10.91	10.91	10.56	10.56	11.89	11.89	6.99	11.49		
WSSV	060	9.53	9.53	13.32	13.32	13.89	13.89	6.99	9.49		
	007, 009, 012	5.79	5.79	9.78	9.78	5.22	5.22	9.58	6.58		
	015, 019	6.0	6.0	10.38	10.38	9.43	9.43	5.97	5.97		
	024, 030	11.47	11.47	9.43	9.43	10.38	10.38	6.75	10.75		
	036	11.47	11.47	9.43	9.43	10.38	10.38	5.75	9.75		
	042	10.91	10.91	10.56	10.56	11.89	11.89	6.99	11.49		
	048	10.91	10.91	10.56	10.56	11.89	11.89	6.99	11.89		
WSTV	060, 070	9.53	9.53	13.32	13.32	13.89	13.89	6.99	9.49		
	024, 030	11.47	11.47	9.43	9.43	10.38	10.38	6.75	10.75		
	036	11.47	11.47	9.43	9.43	10.38	10.38	5.75	9.75		
	042	10.91	10.91	10.56	10.56	11.89	11.89	6.99	11.49		
	048	10.91	10.91	10.56	10.56	11.89	11.89	6.99	11.89		

NOTE 1: *Discharge opening dimensions are with the flanges bent up along the perforations at 90 degrees.

NOTE 2: Dimensions within ± 0.10 inches (2.5 mm).

Figure 17: No Filter Rack & Duct Collar Connections

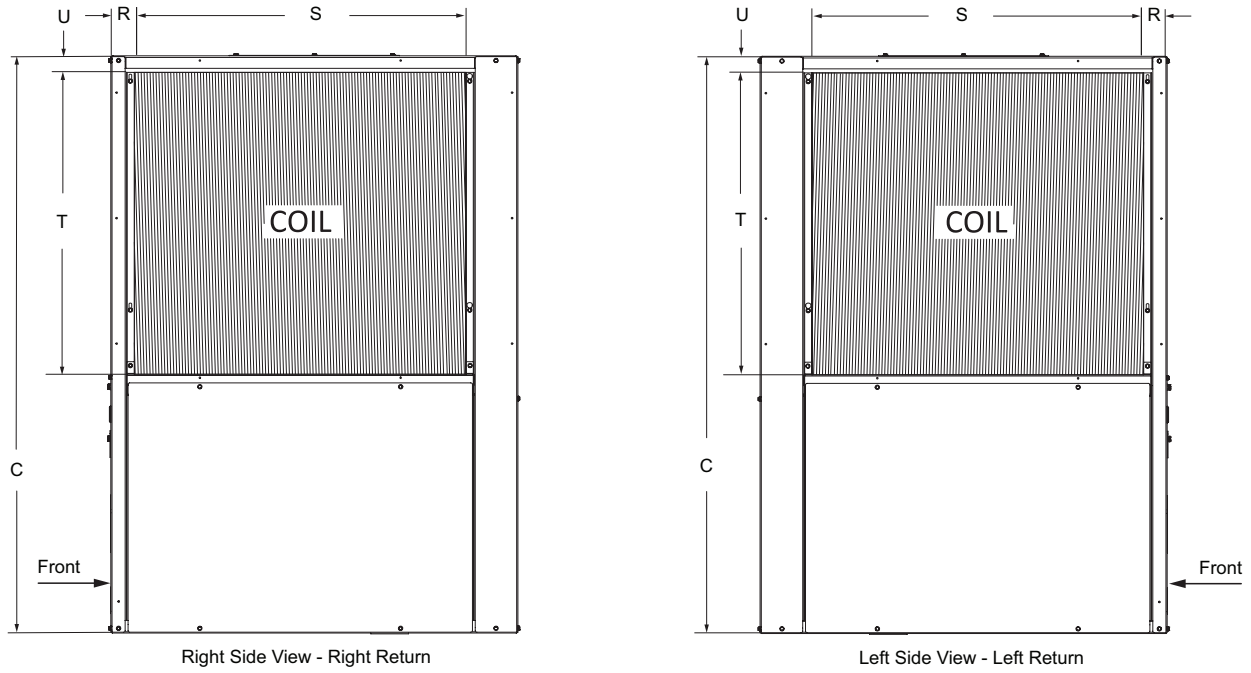

Figure 18: 1" Filter Rack & Duct Collar Connections

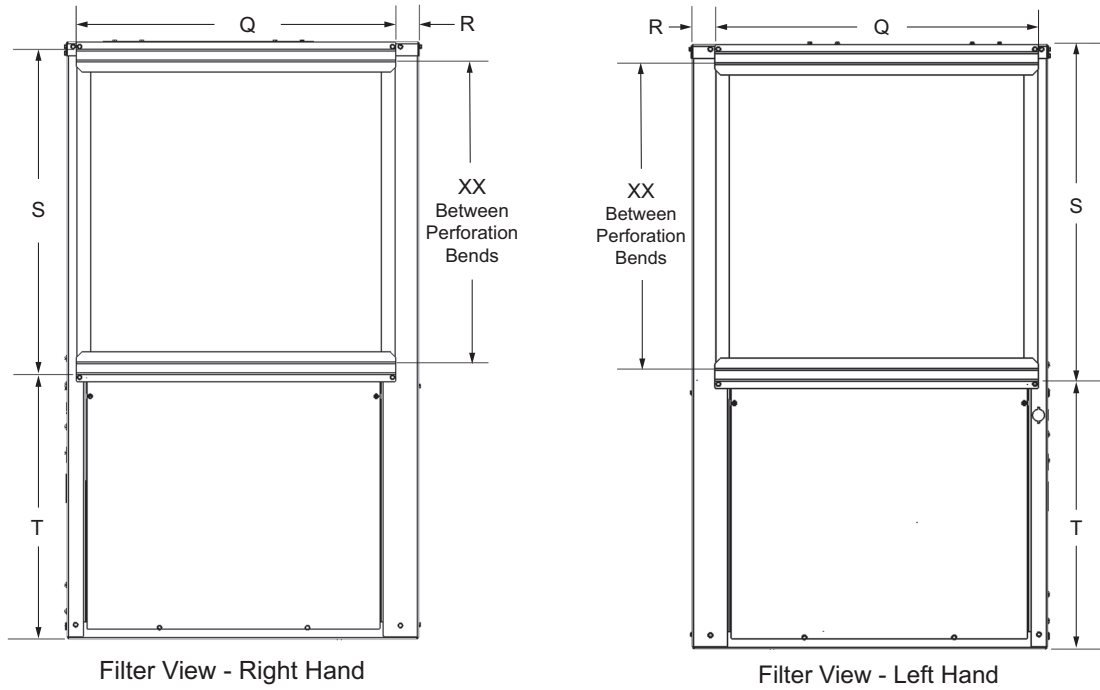

Table 11: Unit with No Filter Rack Dimensions in Figure 17

Unit Model	Unit Size	Unit Height	Air Coil Return Air Opening			
		C	Offset Side	Coil Width	Coil Height	Offset Top
			R	S	T	U
WSCV	007, 009, 012	24.0	3.63	14.0	12.13	1.0
	015, 019	34.0	3.63	16.5	15.59	1.0
	024, 030	38.0	3.63	16.5	20.79	1.0
	036, 042	44.0	3.63	21.0	24.25	1.0
	048, 060, 070	46.0	4.15	27.0	25.98	1.0
WSMV	007, 009, 012	30.3	3.63	14.0	17.32	1.0
	015, 019	38.0	3.63	16.5	19.06	1.0
	024, 030	44.0	3.63	21.0	24.25	1.0
	036, 042	46.0	4.15	27.0	25.98	1.0
	048, 060	50.5	4.13	27.0	29.45	1.0
WSSV	007, 009, 012	34.0	3.63	16.5	15.59	1.0
	015, 019	44.0	3.63	21.0	19.06	5.4
	024, 030	46.0	4.15	27.0	25.98	1.0
	036, 042	50.5	4.13	27.0	29.45	1.0
	048, 060, 070	54.0	4.13	27.0	32.91	1.0
WSTV	024, 030	46.0	4.15	27.0	25.98	1.0
	036, 042	50.5	4.13	27.0	29.45	1.0
	048, 060, 070	54.0	4.13	27.0	32.91	1.0

Table 12: 1" Filter Rack Dimensions in Figure 18

Unit Model	Unit Size	Filter Rails Location				Dimensions Between 90-Degree Perforation Bends
		Q	R	S	T	XX
WSCV	007, 009, 012	17.53	0.71	11.92	13.01	9.78
	015, 019	20.03	0.71	15.29	18.63	13.16
	024, 030	20.03	0.71	20.76	19.16	18.63
	036, 042	24.53	0.71	23.76	20.16	21.63
	048, 060, 070	31.0	0.85	25.82	20.1	23.69
WSMV	007, 009, 012	17.53	0.71	17.17	13.01	15.03
	015, 019	20.03	0.71	20.76	19.16	18.63
	024, 030	24.53	0.71	23.76	20.16	21.63
	036, 042	31.0	0.85	25.82	20.1	23.69
	048, 060	31.0	0.85	29.26	21.16	27.13
WSSV	007, 009, 012	20.03	0.71	15.29	18.63	13.16
	015, 019	24.53	0.71	23.76	20.16	21.63
	024, 030	31.0	0.85	25.82	20.1	23.69
	036, 042	31.0	0.85	29.26	21.16	27.13
	048, 060, 070	31.0	0.85	32.76	21.16	30.63
WSTV	024, 030	31.0	0.85	25.82	20.1	23.69
	036, 042	31.0	0.85	29.26	21.16	27.13
	048, 060, 070	31.0	0.85	32.76	21.16	30.63

NOTE 1: Filter rack flange dimensions are to the outside edge of the flange. Dimensions are approximate as the return air duct flanges are bent out along the perforations by the installing contractor.

Figure 19: 2" and 4" Filter Rack Dimensions

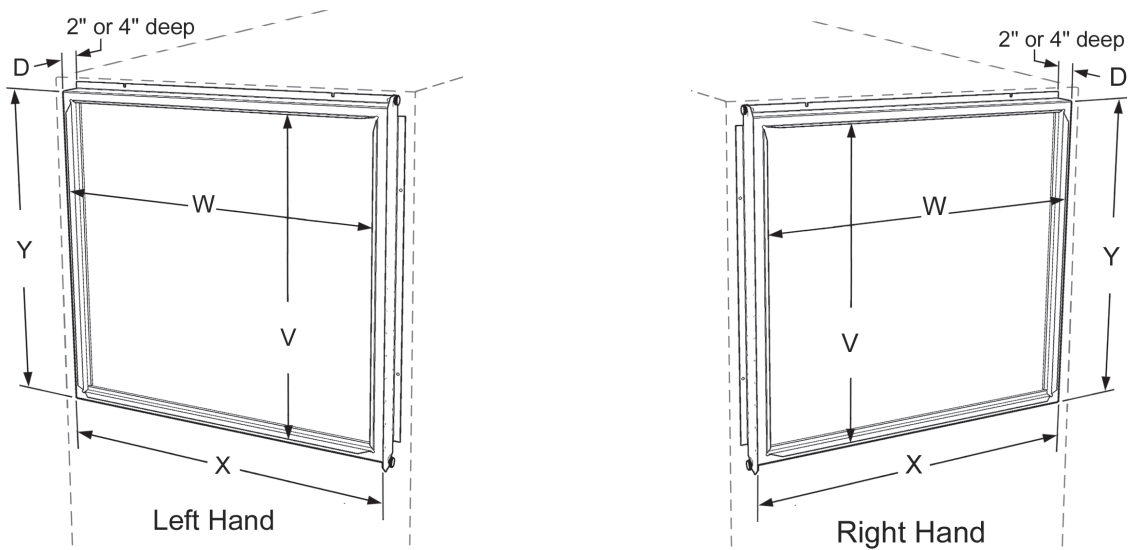

Table 13: 2" and 4" Filter Rack Dimensions in Figure 19

Unit Model	Unit Size	Air Coil Return Air Opening					
		Duct Flange Width	Duct Flange Height	2"	4"	Filter Rack Width	Filter Rack Height
		W	V	D		X	Y
WSCV	007, 009, 012	15.57	9.2	2.125	4.125	17.54	10.88
	015, 019	18.07	12.57	2.125	4.125	20.04	14.24
	024, 030	18.07	18.07	2.125	4.125	20.04	19.75
	036, 042	22.6	21.07	2.125	4.125	24.5	22.8
	048, 060, 070	29.07	23.07	2.125	4.125	31.0	24.75
WSMV	007, 009, 012	15.57	14.45	2.125	4.125	17.54	16.13
	015, 019	18.07	18.07	2.125	4.125	20.04	19.75
	024, 030	22.6	21.07	2.125	4.125	24.5	22.8
	036, 042	29.07	23.07	2.125	4.125	31.0	24.75
	048, 060	29.07	26.57	2.125	4.125	31.04	28.25
WSSV	007, 009, 012	18.07	12.57	2.125	4.125	20.04	14.25
	015, 019	22.6	21.07	2.125	4.125	24.5	22.8
	024, 030	29.07	23.07	2.125	4.125	31.0	24.75
	036, 042	29.07	26.57	2.125	4.125	31.04	28.25
	048, 060, 070	29.07	30.07	2.125	4.125	31.04	31.75
WSTV	024, 030	29.07	23.07	2.125	4.125	31.04	24.75
	036, 042	29.07	26.57	2.125	4.125	31.04	28.25
	048, 060, 070	29.07	30.07	2.125	4.125	31.04	31.75

NOTE 1: Filter rack flange dimensions are to the outside edge of the flange. Dimensions are approximate as the return air duct flanges are bent out along the perforations by the installing contractor.

Field Installed Accessories

Motorized Isolation Valve Kit

The motorized valve kit is available as a factory-installed or a field-installed option. Wired as shown in Figure 20, the motorized valve will open on a call for compressor operation. The motorized isolation valve actuator (ISO) has both a 24V power connection and a 24V end switch connection.

1. Install the supplied wire harness into plug H6 on the main control board.

2. Run wires between the ISO actuator and the supplied wire harness ends.
3. Connect N.O. & N.C. actuators as shown on the schematic.
4. The end switch should be wired in series with the 24V compressor signal wire. Connect the end switch wires as shown in the schematic. The end switch will close when the valve is fully open.

NOTICE

For detailed installation instructions for the motorized valve, refer to IM 1151.

Figure 20: Motorized Valve Wiring

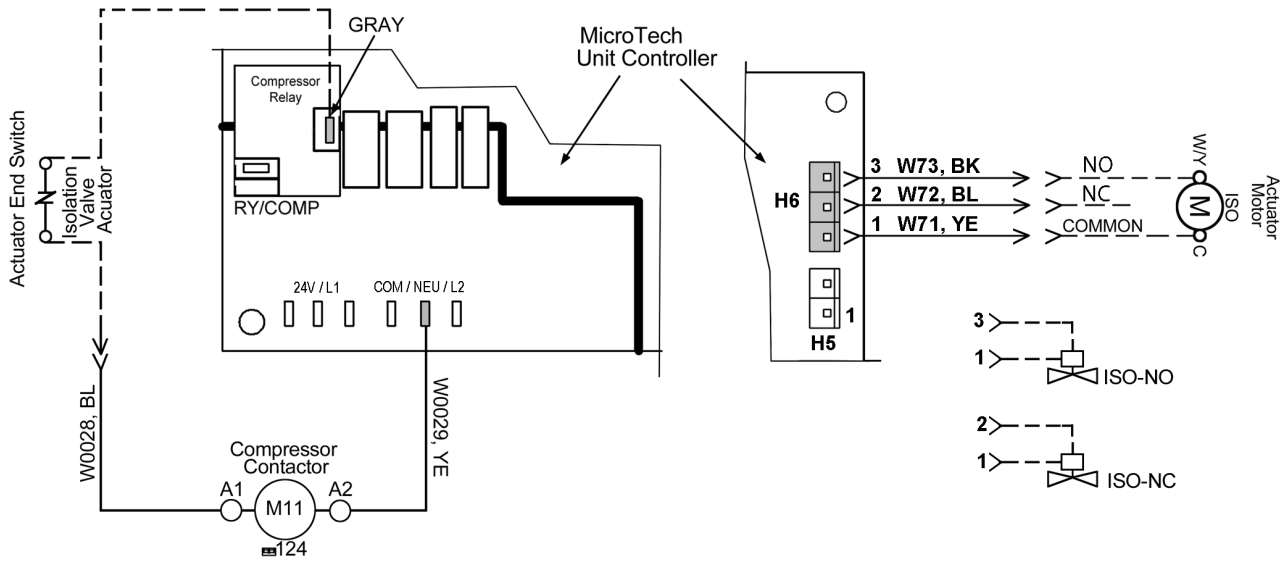

NOTE: Image is representative and board may differ slightly.

Figure 21: MT2300 wiring to an existing motorized valve from a previously installed unit with MicroTech III controller

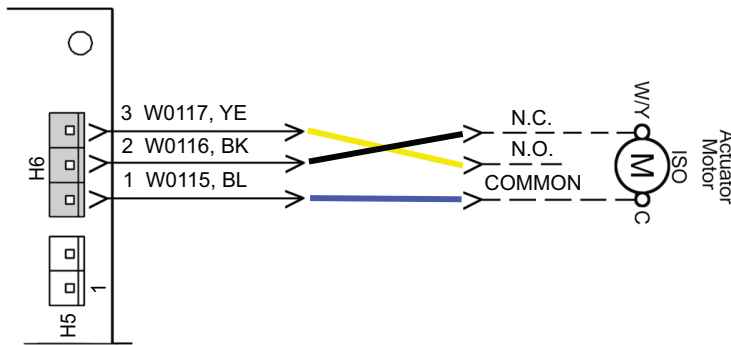

NOTE: If reusing a motorized valve on an existing Daikin Applied R-410A unit, the wiring harness for connections 1, 2, and 3 for the R32 product are different. Therefore, the wiring connections (Common, N.O., and N.C.) to the motorized valve must be rewired.

Electrical

WARNING

All field installed wiring must comply with local and national electrical codes. This equipment presents hazards of electricity, rotating parts, sharp edges, heat and weight. Failure to read and follow these instructions can result in property damage, personal injury, or death. This equipment must be installed by experienced, trained personnel only.

WARNING

Use copper conductors only. Conductor insulation must be rated for a minimum temperature of 167°F (75°C).

CAUTION

Fasteners should not be screwed into and penetrate the unit enclosure to avoid damage to internal electrical and mechanical components.

Table 14: Operating Voltages

Voltage	Minimum	Maximum
115/60/1	103	126
208-230/60/1	197	253
265/60/1	238	292
208-230/60/3	197	253
460/60/3	414	506
575/60/3	515	632

- NOTE 1:** Three-phase system imbalance shall not exceed 2%.
- NOTE 2:** Use a short length of flexible conduit at the unit connection to minimize and isolate vibration to the building. All conduit should be supported to avoid contact with unit cabinet or immediate building structure to prevent unnecessary noise.
- NOTE 3:** All 208-230 volt single-phase and three-phase units are factory wired for 208 volt operation. When installing a 208-230 volt unit, ensure the correct wire is connected to the transformer.

230 Volt Operation

All 208-230 volt single-phase and three-phase units are factory wired for 208 volt operation. For 230 volt operation, the RED primary lead wire from the transformer must be disconnected from contactor, and replaced with the ORANGE wire from the transformer. See Figure 22.

Three-Phase Line Voltage (208-230, 460, 575V)

DANGER

LOCKOUT/TAGOUT all power sources prior to wiring or servicing the unit. Hazardous voltage can cause serious injury or death. Disconnect electric power before servicing equipment. More than one disconnect may be required to de-energize the unit.

1. Route line voltage supply wiring through the lower 1-1/8" diameter knockout in the left corner post.
2. Wires should extend through the lower left side of the control box. Route wires through wire ties where provided.

3. Remove and discard the factory provided stripped wire leads from the left side unit contactor screw terminals (not shown).
4. Connect the field supplied wires to the left side contactor screw terminals as shown in Figure 23.
5. Connect ground wire to provided (green) ground screw.
6. Twist neutral wires and wire nut (460V units only).

Figure 22: For 230 Volt Operation, Disconnect the RED Transformer Wire at the Contactor and Replace with the ORANGE Wire

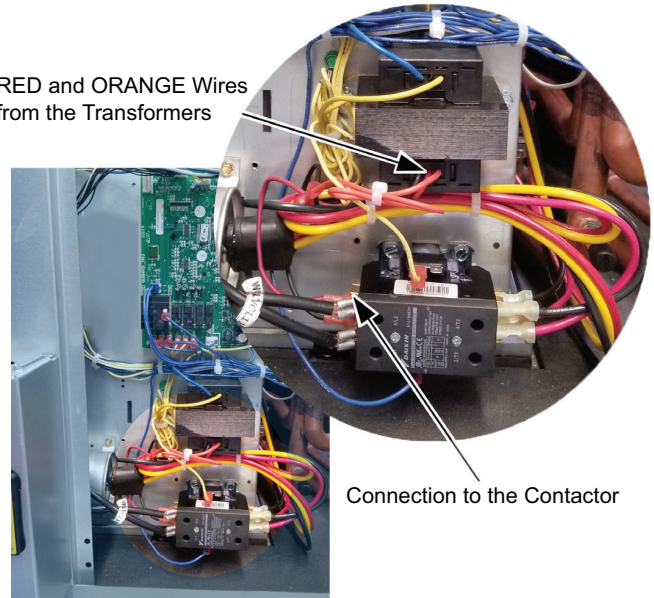
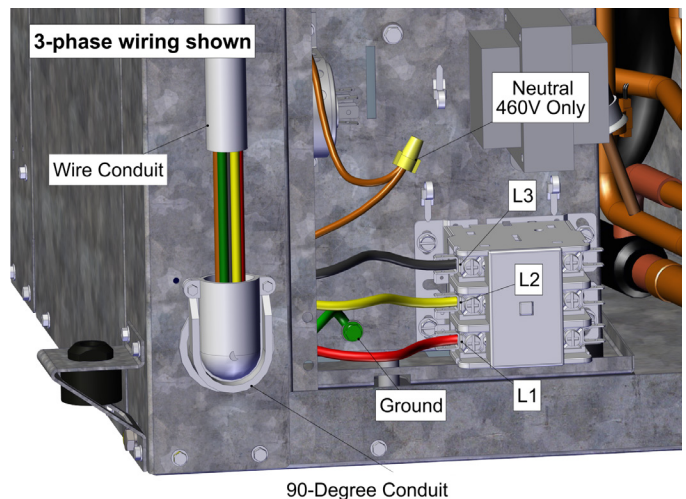

Figure 23: Route Line Voltage Wires to Terminal Screws



NOTE: Units without constant CFM ECM will not include a neutral conductor. For clarity, not all unit wires are shown in the unit line voltage connection area.

Single Phase Line Voltage (115, 208-230, 265V)

⚠ DANGER

LOCKOUT/TAGOUT all power sources prior to wiring or servicing the unit. Hazardous voltage can cause serious injury or death. Disconnect electric power before servicing equipment. More than one disconnect may be required to de-energize the unit.

1. Route line voltage supply wiring through the lower 1-1/8" diameter electrical knockout in the left corner post.
2. Route wires through wire ties where provided.
3. Connect the field supplied wires to the left side contactor screw terminals as shown in [Figure 24](#).
4. Secure ground wire to (green) ground screw.

Figure 24: Line Voltage Wiring Route to Wire Connections

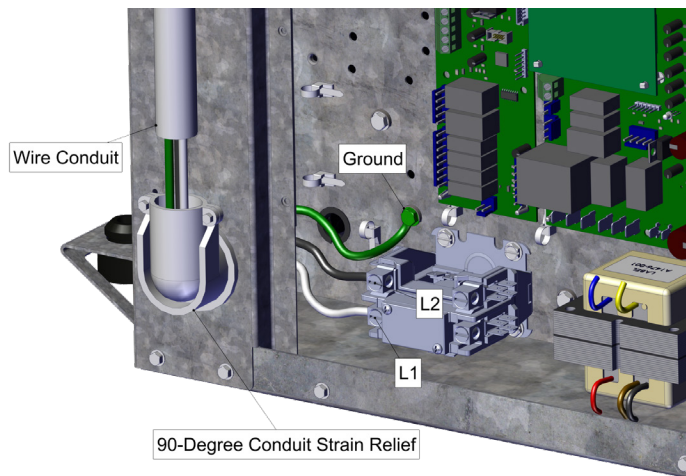

Line Voltage Electrical Connections with Disconnect – 115-575V

⚠ DANGER

LOCKOUT/TAGOUT all power sources prior to wiring or servicing the unit. Hazardous voltage can cause serious injury or death. Disconnect electric power before servicing equipment. More than one disconnect may be required to de-energize the unit.

When units are equipped with the optional non-fused disconnect switch, the line voltage supply is brought in through the top of the junction box. Disconnect location and dimension details are provided in [Figure 25](#).

NOTICE

The disconnect location may vary depending on the return air handling. See [Figure 25](#). Right-hand unit shown, with switch mounted on the opposite corner post from return air.

460V units with constant CFM ECM require a neutral conductor. See number bubble "6" in [Figure 25](#).

1. Remove screws from the top and bottom locations on the disconnect switch cover.
2. These are the factory-installed wires from the switch to the line voltage terminals in the unit control box.
3. Connect wires to the upper unused terminals.
4. Tighten terminal screws to secure wires.
5. Connect ground wire to provided green ground screw.
6. Connect field provided neutral conductor, if required.
7. Replace cover and secure with screws.

Figure 25: 460V Wiring with Neutral Wire (Constant CFM ECMs Only) to The Non-Fused Disconnect Switch

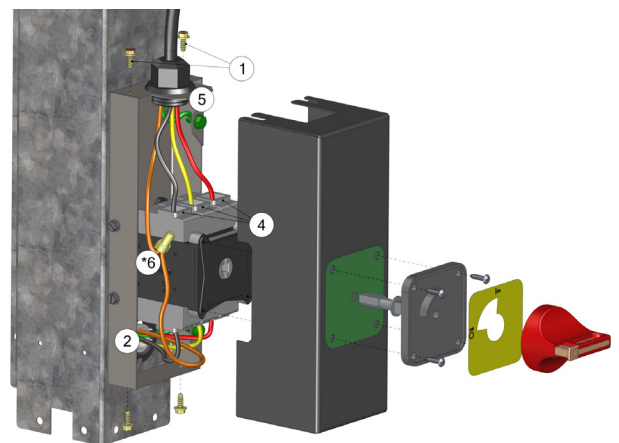

Figure 26: Unit with Optional Non-Fused Disconnect Switch

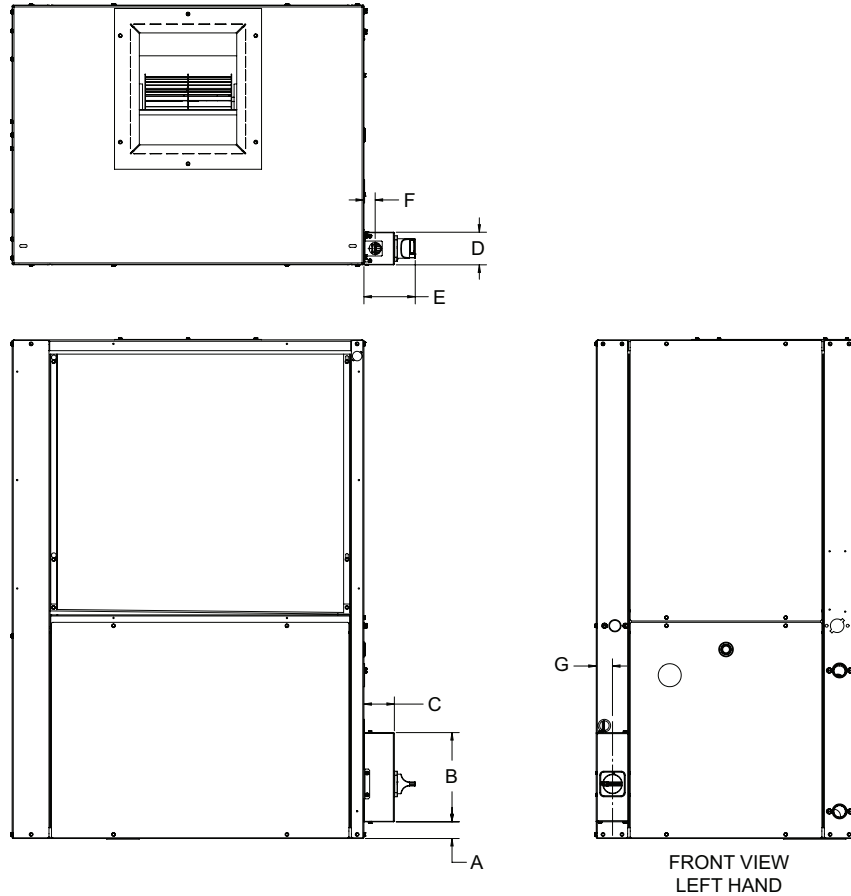

Table 15: Optional Non-Fused Disconnect Switch Dimensions for Figure 26

Unit Model	Unit Size	Optional Power Non-Fused Disconnect Switch						
		A	B	C	D	E	F	G
WSCV	007, 009, 012	1.54	8.23	2.81	3.01	4.73	1.04	1.5
	015, 019	1.54	8.23	2.81	3.01	4.73	1.04	1.5
	024, 030	1.54	8.23	2.81	3.01	4.73	1.04	1.5
	036, 042	1.54	8.23	2.81	3.01	4.73	1.04	1.5
	048, 060, 070	1.54	8.23	2.81	3.01	4.73	1.04	1.5
WSMV	007, 009, 012	1.54	8.23	2.81	3.01	4.73	1.04	1.5
	015, 019	1.54	8.23	2.81	3.01	4.73	1.04	1.5
	024, 030	1.54	8.23	2.81	3.01	4.73	1.04	1.5
	036, 042	1.54	8.23	2.81	3.01	4.73	1.04	1.5
	048, 060	1.54	8.23	2.81	3.01	4.73	1.04	1.5
WSSV	007, 009, 012	1.54	8.23	2.81	3.01	4.73	1.04	1.5
	015, 019	1.54	8.23	2.81	3.01	4.73	1.04	1.5
	024, 030	1.54	8.23	2.81	3.01	4.73	1.04	1.5
	036, 042	1.54	8.23	2.81	3.01	4.73	1.04	1.5
	048, 060, 070	1.54	8.23	2.81	3.01	4.73	1.04	1.5
WSTV	024, 030	1.54	8.23	2.81	3.01	4.73	1.04	1.5
	036, 042	1.54	8.23	2.81	3.01	4.73	1.04	1.5
	048, 060, 070	1.54	8.23	2.81	3.01	4.73	1.04	1.5

Low Voltage Wire Connections

NOTICE

Never install relay coils in series or parallel with the thermostat inputs.

NOTICE

Units equipped with dehumidification control require installation of a factory supplied return air sensor connected to I/O H4-3/4 terminal. See [Figure 47](#) on [page 48](#) for details.

1. Route the field-supplied low voltage wiring through the upper knockout in the left corner post as shown in [Figure 13](#).
2. Secure the low voltage wire connections to the terminals shown in [Figure 27](#) and [Figure 28](#). Refer to "Typical Connections for Thermostats & Temperature Sensors Applications" on [page 48](#) for I/O Expansion Module terminal TB1 connections.

Figure 27: Terminal Connection Locations on the MicroTech Board

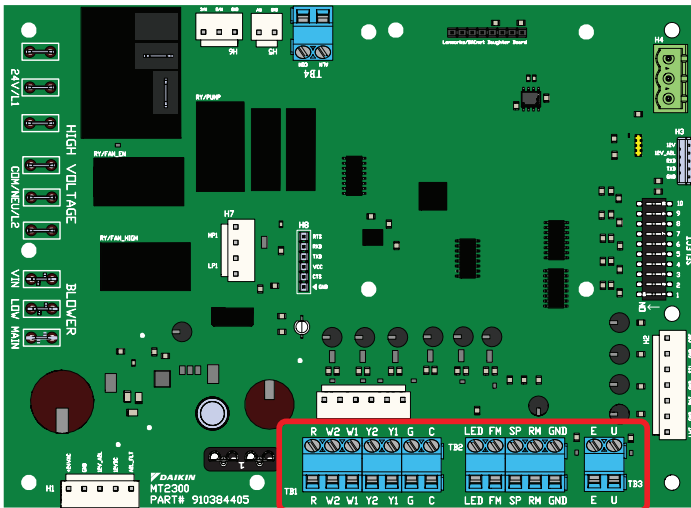
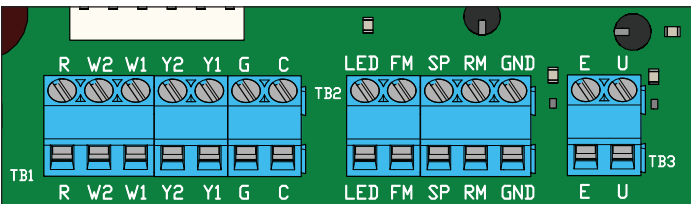

Figure 28: Terminal Connections TB1 (Thermostat Control) and TB2 (Sensor Control) on the MicroTech Board



Control Wiring Schematics

Figure 29: MicroTech Unit Control with PSC Motor - 208-230, 265, 460, 575 Volt

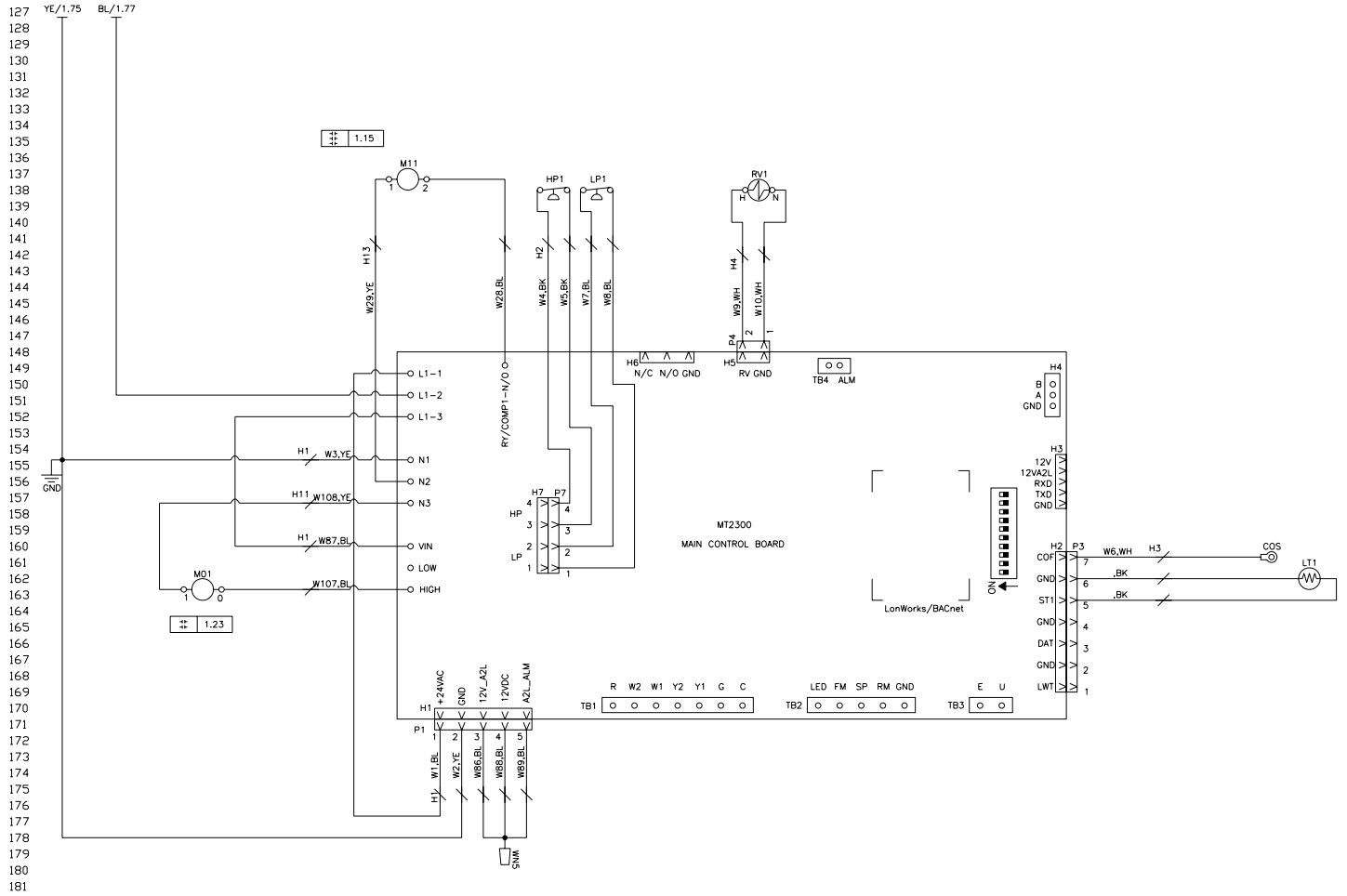

Figure 30: MicroTech Unit Control with Constant Torque ECM - 115 Volt - No Options

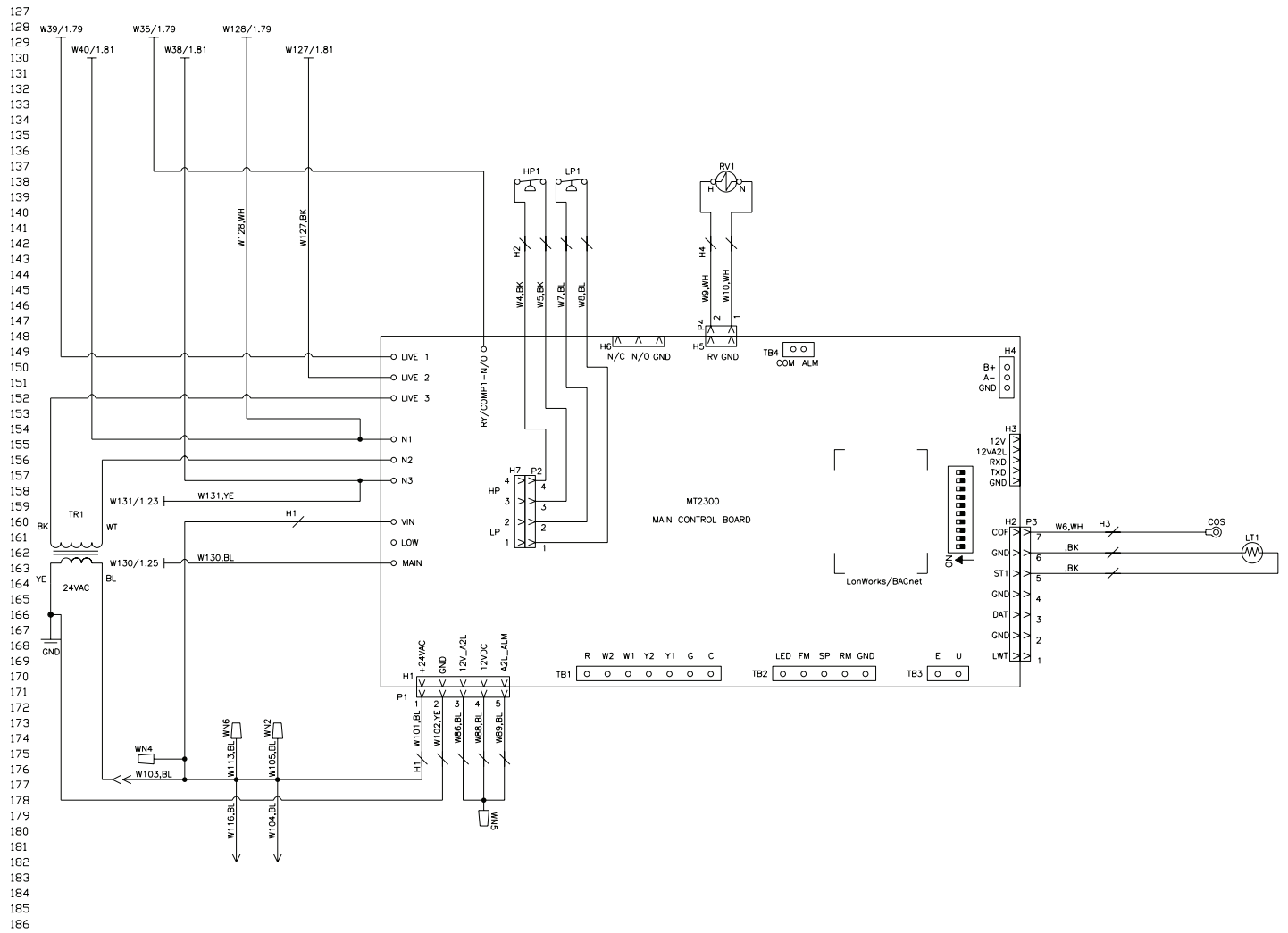

Figure 31: MicroTech Unit Control with Constant Torque ECM with Waterside Economizer

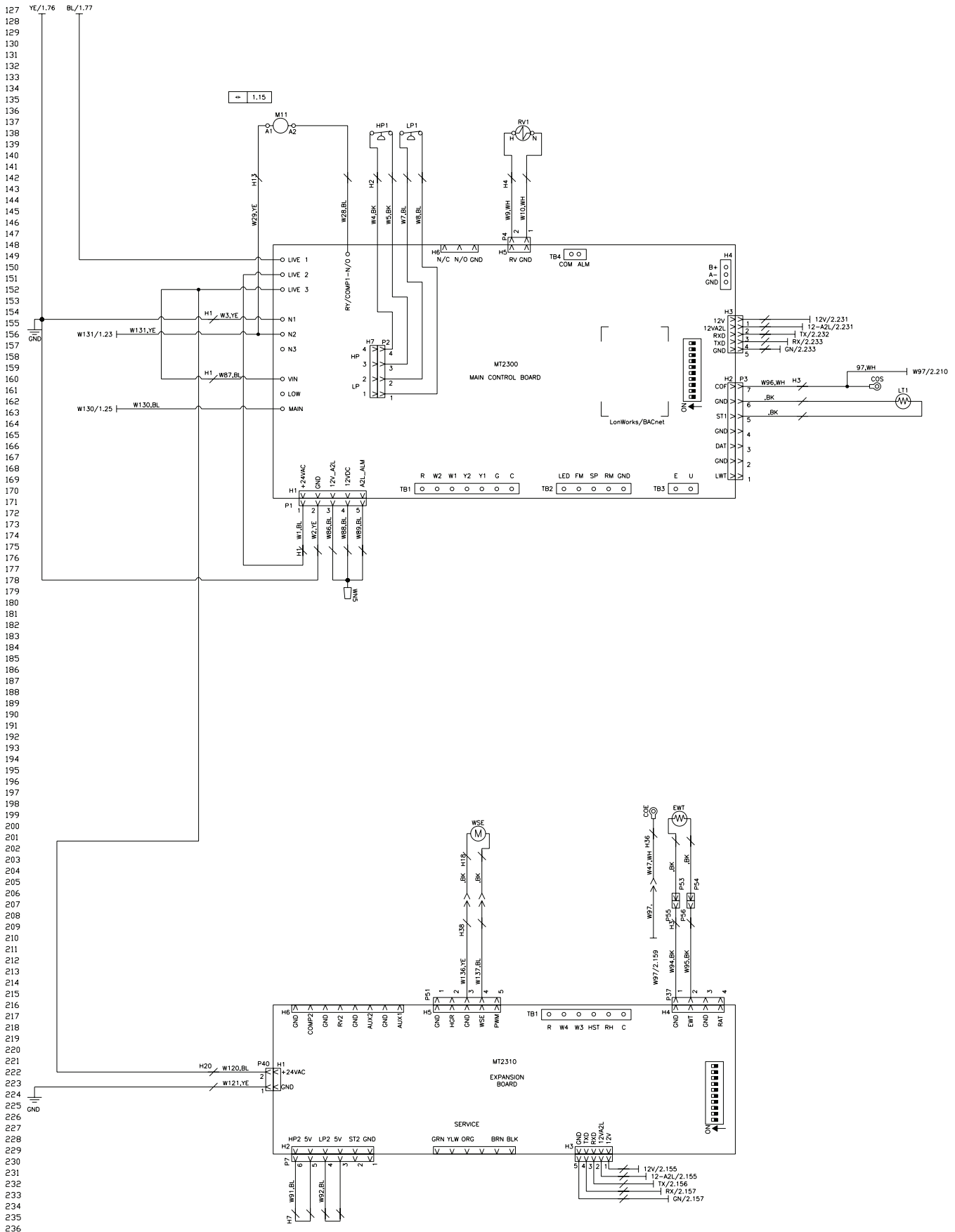

Figure 32: MicroTech Unit Control with Constant CFM ECM with Hot Gas Reheat

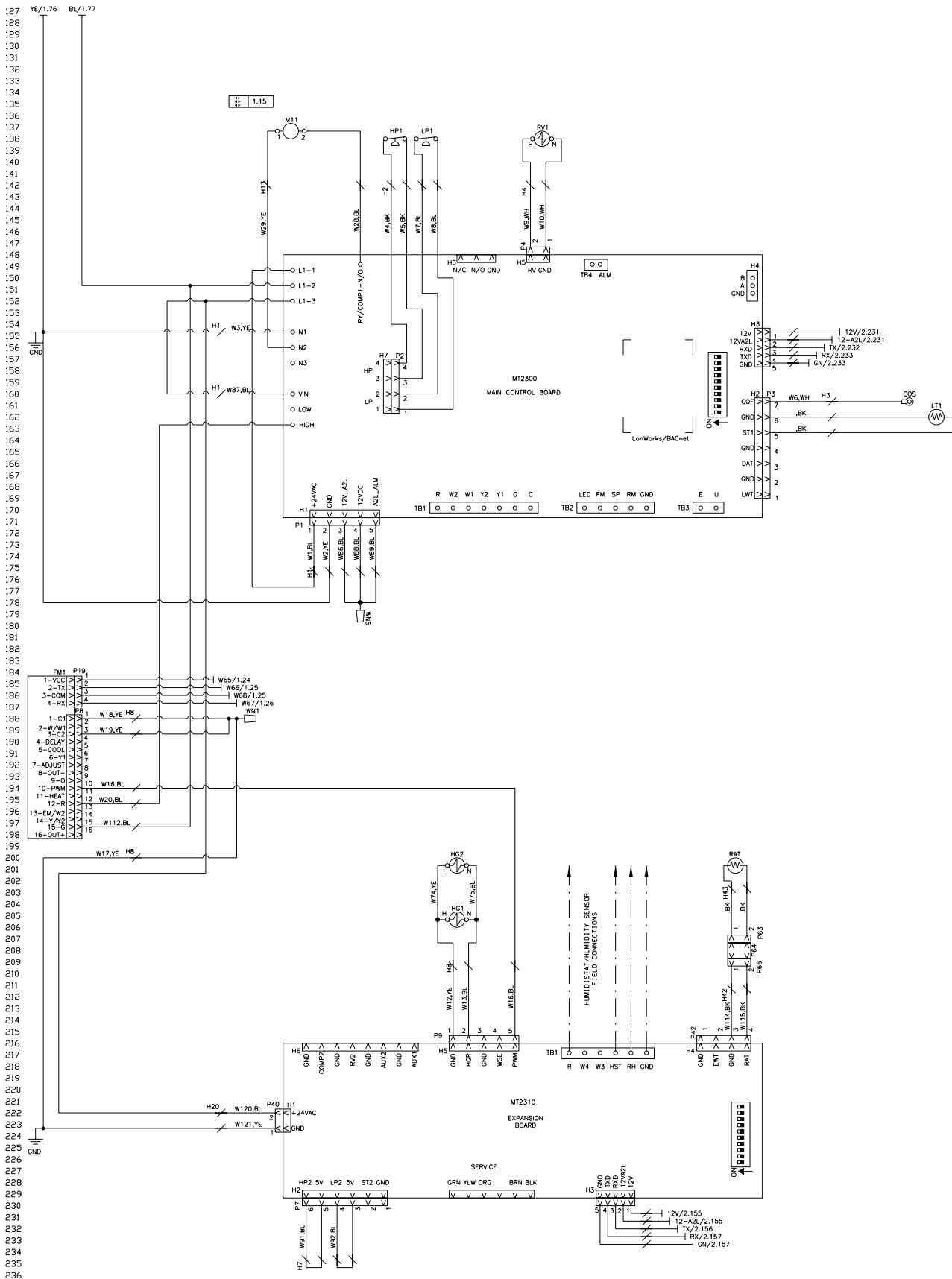

Figure 33: MicroTech Unit Control with Constant CFM ECM - 2-Stage Unit

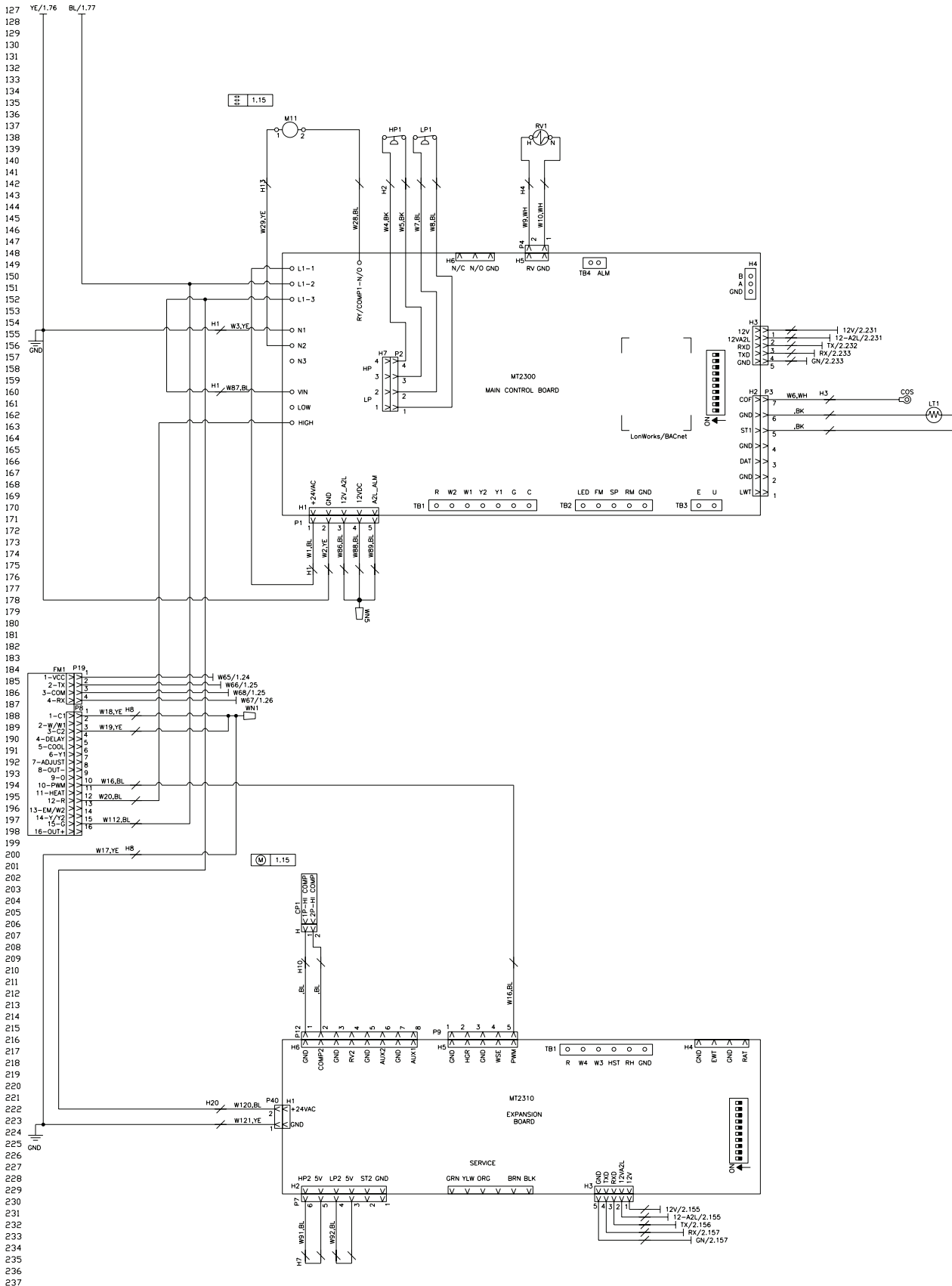

Figure 34: MicroTech Unit Control with Constant CFM ECM with Electric Heat Control Wiring

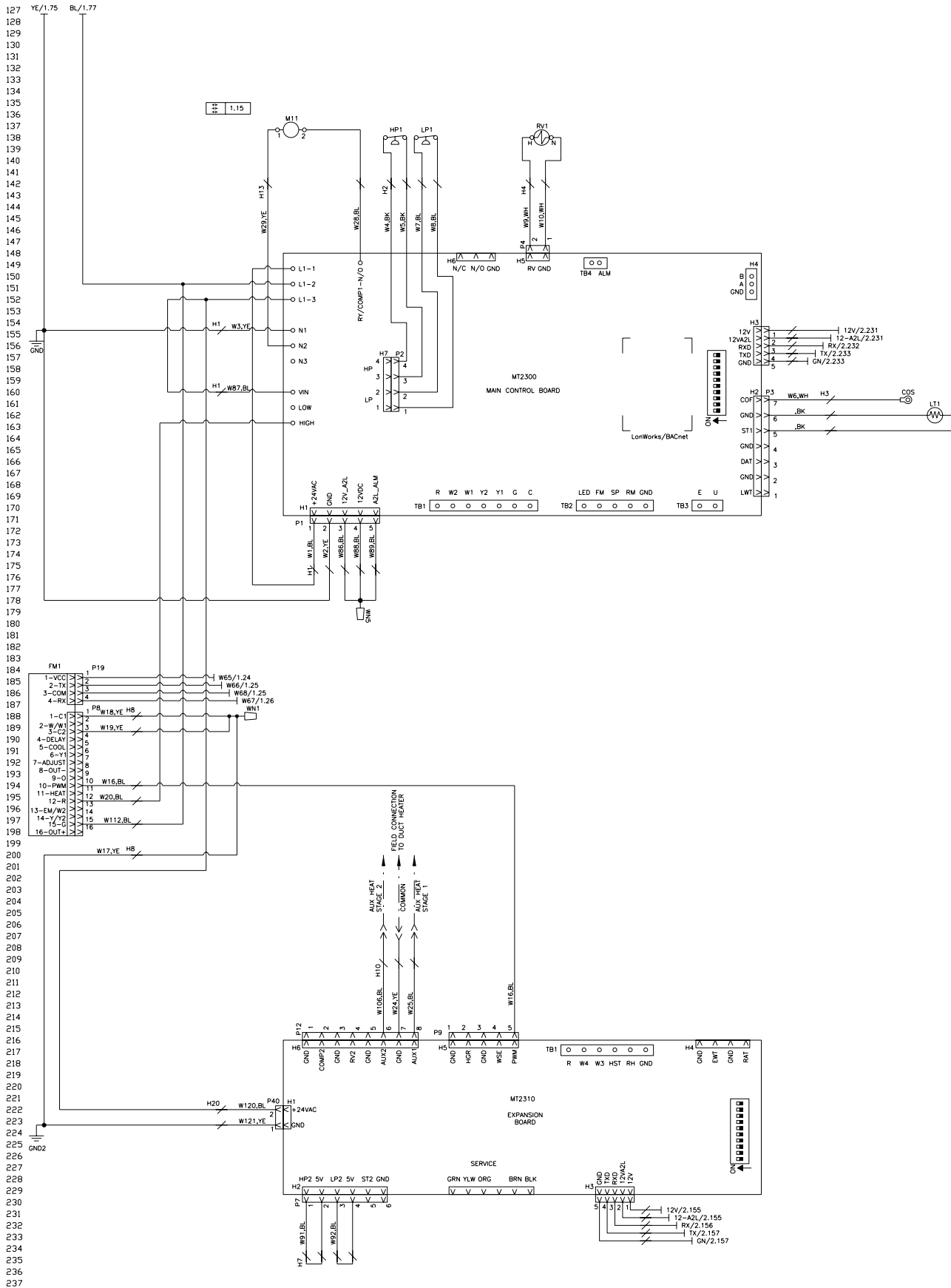
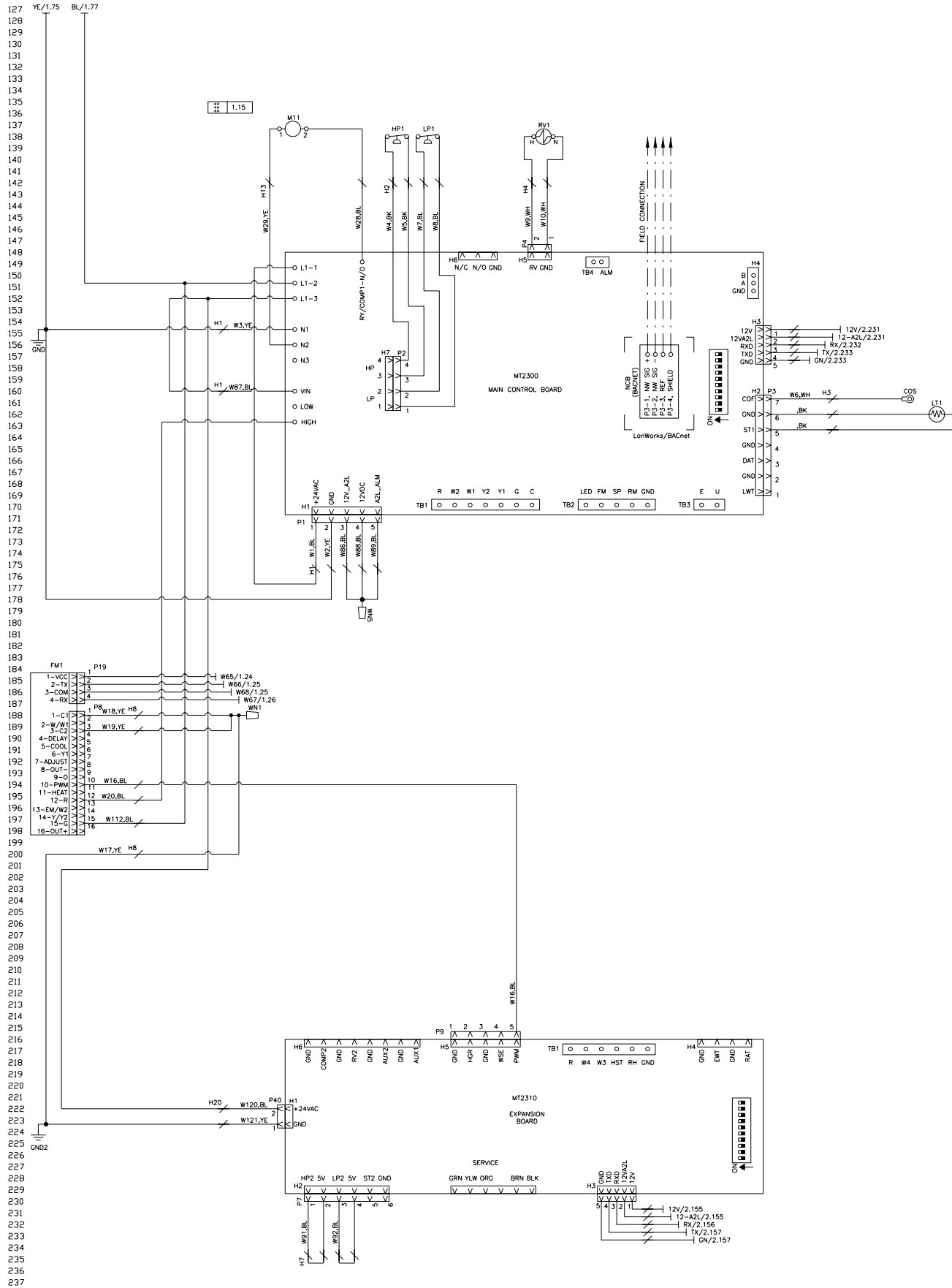

Figure 35: MicroTech Unit Control with Constant CFM ECM with BACnet Communication Module



Line Voltage Wiring Schematics

Figure 36: 115V/60Hz/1Ph with PSC Motor

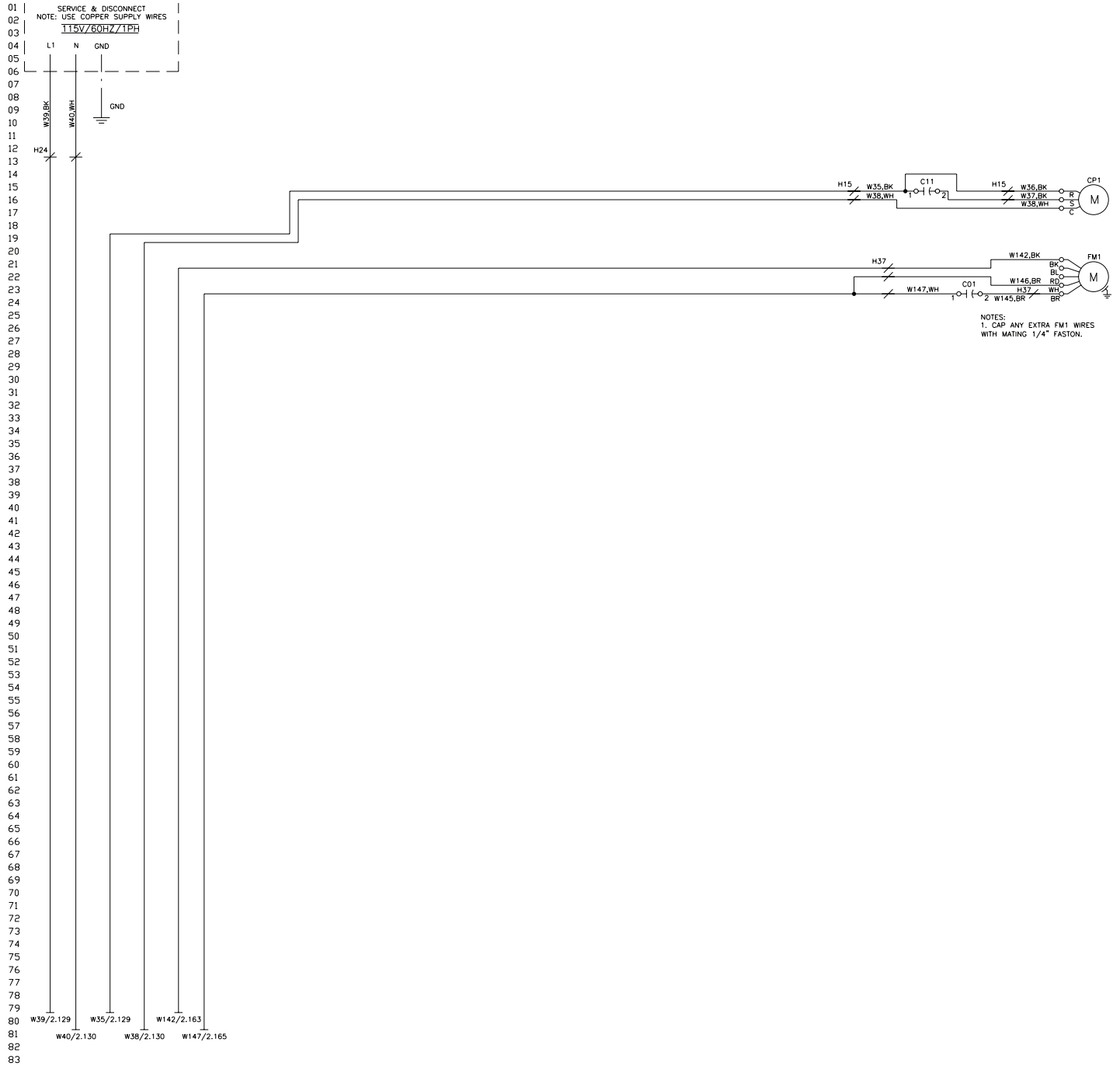

Figure 37: 115V/60Hz/1Ph with Constant Torque ECM

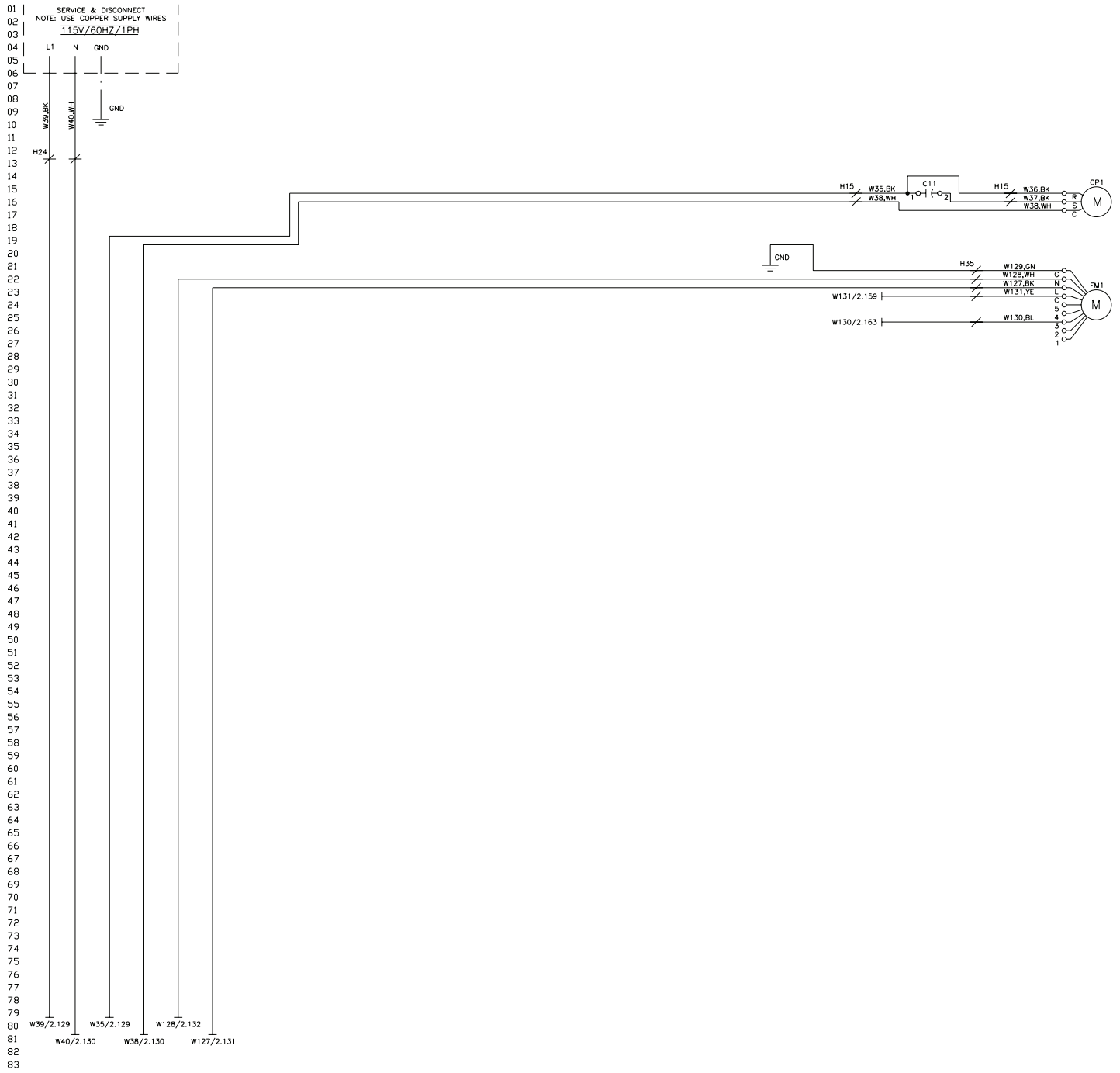

Figure 38: 265V/60Hz/1Ph with Constant Torque ECM

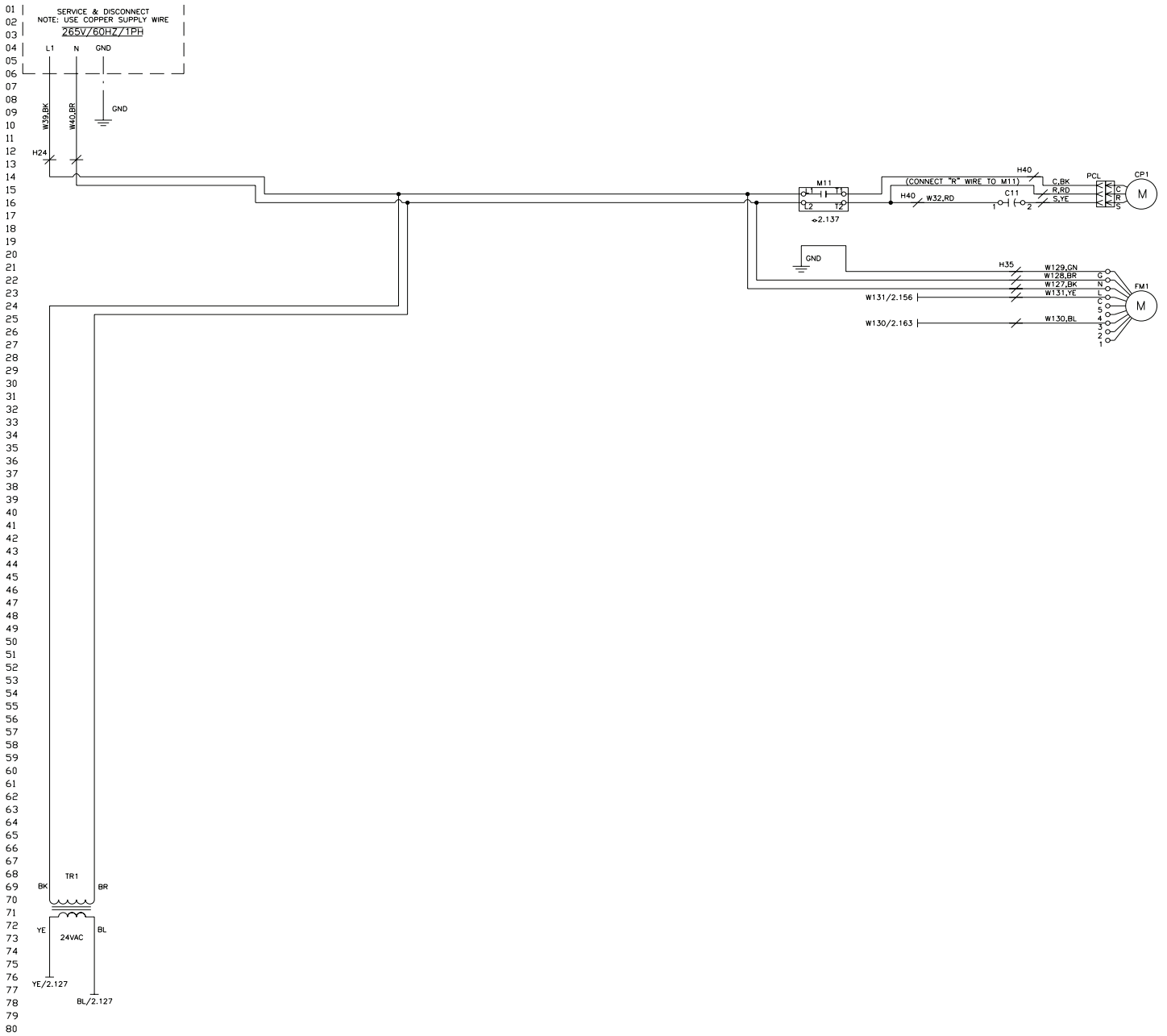

Figure 39: 208-230V/60Hz/3Ph with Constant Torque ECM

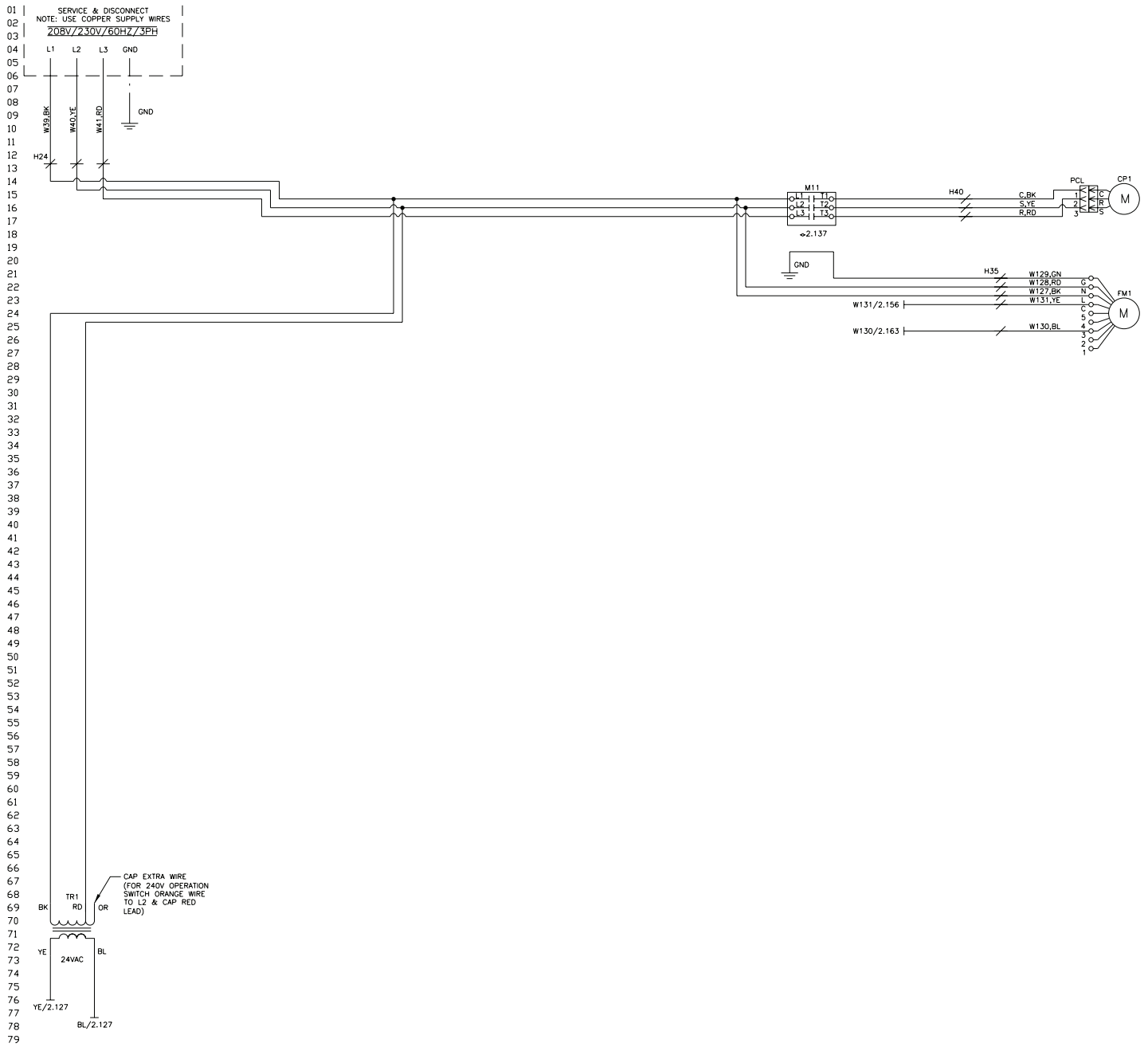

Figure 40: 265-277V/60Hz/1Ph, 208-230V/60Hz/1Ph with PSC Motor

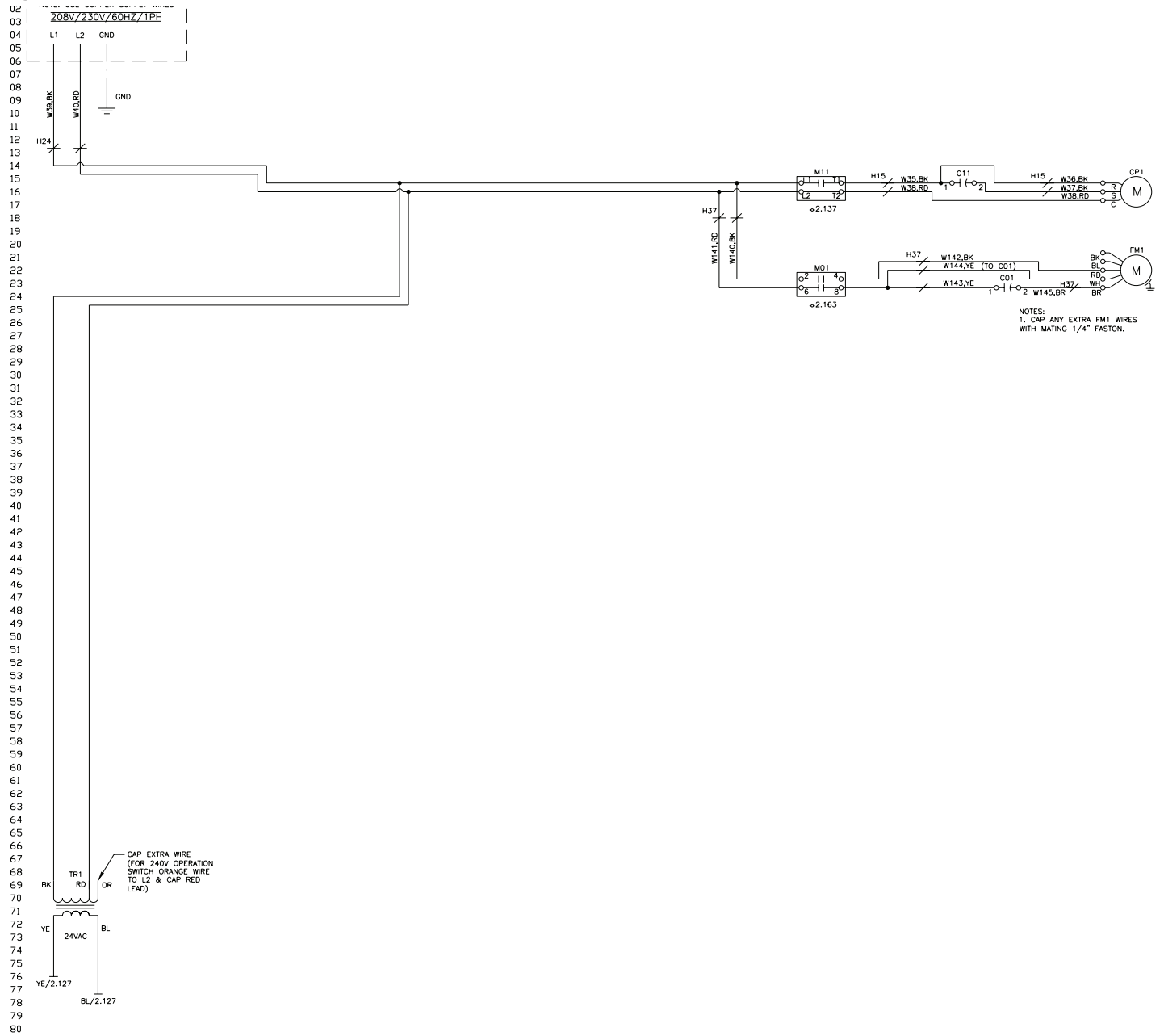

Figure 41: 460V/60Hz/3Ph, 575V/60Hz/3Ph, 208-230V/60Hz/3Ph with PSC Motor

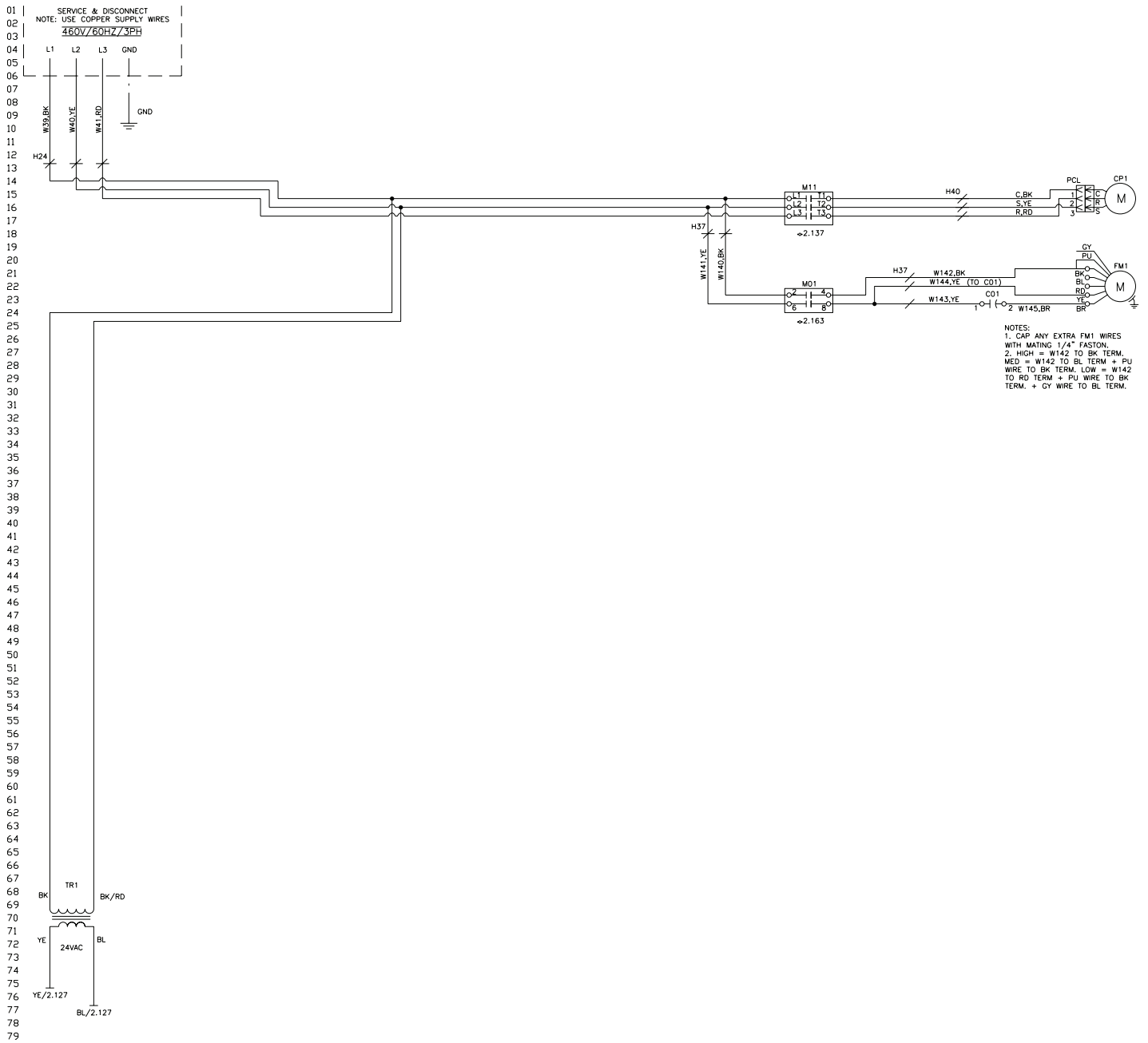

Figure 42: 208-230V/60Hz/3Ph with Constant CFM EC 2-Stage Motor

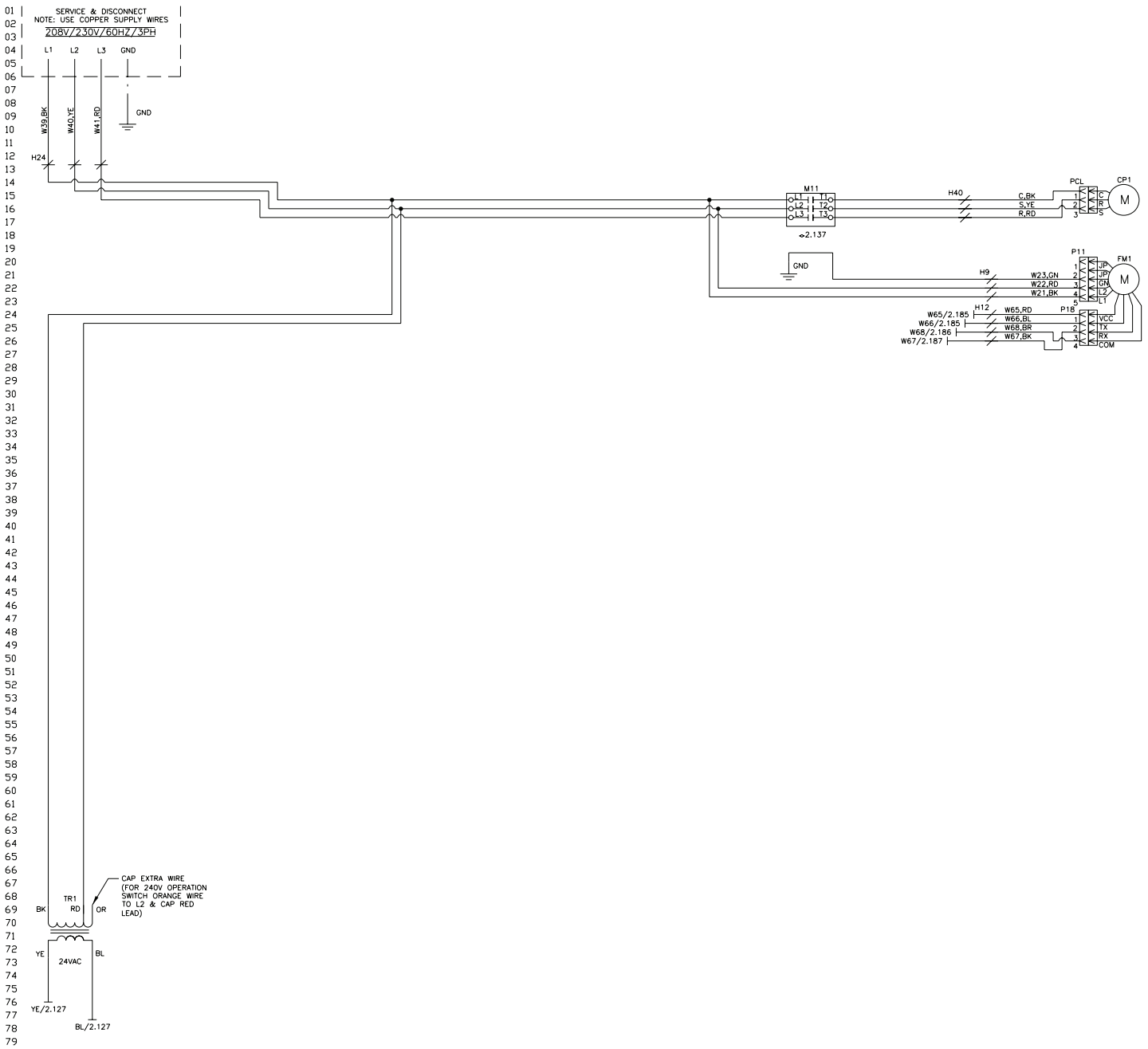
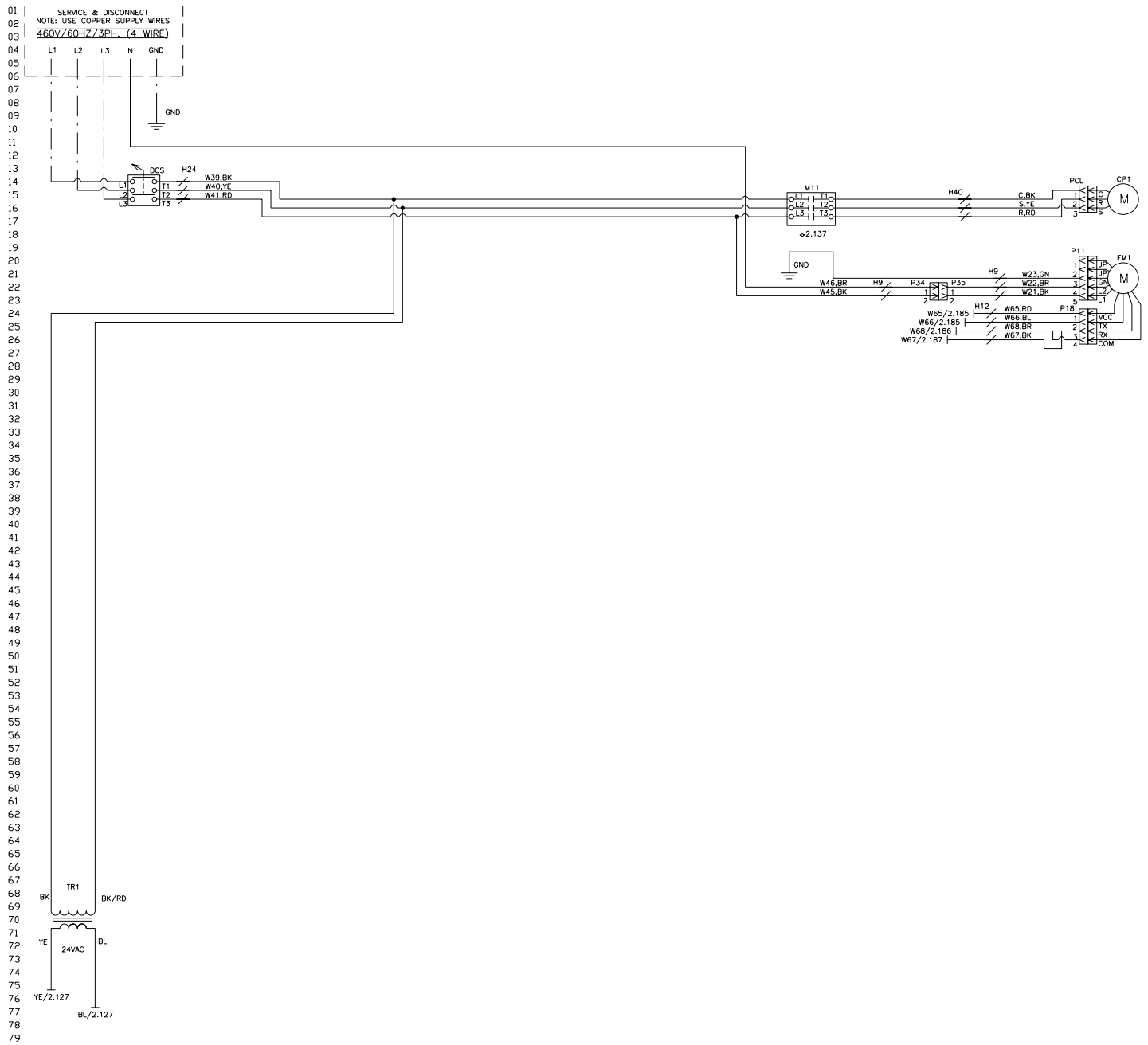

Figure 43: 460V/60Hz/3Ph with Constant CFM ECM with Electric Heat Control



Wiring Schematics Legend for "Control Wiring Schematics"

LEGEND	
CO1	Fan Motor 1 Capacitor
C11	Compressor 1 Capacitor
CP1	Compressor 1
COE	Condensate Overflow Protection Sensor - WSE
COS	Condensate Overflow Protection Sensor
DAT	Discharge Air Temperature Sensor
DCS	Disconnect Switch
EWT	Entering Water Temperature Sensor
FM1	Fan Motor 1
GND	Ground
HG1	Hot Gas Reheat Valve Actuator
HP1	High Pressure Switch
HYH	Hot Water Heat Valve Actuator
LAT	Leaving Air Temperature Sensor
LP1	Low Pressure Switch
LT1	Compressor Suction Line Temperature Sensor
LWT	Leaving Water Temperature Sensor
M01	Fan Motor Contactor
M11	Compressor 1 Contactor
NCB	Network Control Board
OLP	Overload Protector - Compressor Motor
RAT	Return Air Temperature Sensor
RV1	Reversing Valve
TR1	Transformer - Control
TR2	Transformer - Fan Motor
W0001	Wire
WH001	Wire Harness
WN1	Wire Nut
WP001	Wire Plug
WSE	Waterside Economizer Actuator

NOTE: Devices in legend may or may not be on unit.

Typical Connections for Thermostats & Temperature Sensors Applications

Figure 44: Wiring Example for Two-Stage Thermostat with Electrical Heat and Hot Gas Reheat. (Y2 Connection on MircoTech Controller Should Be Used To Achieve Rated Capacity.)

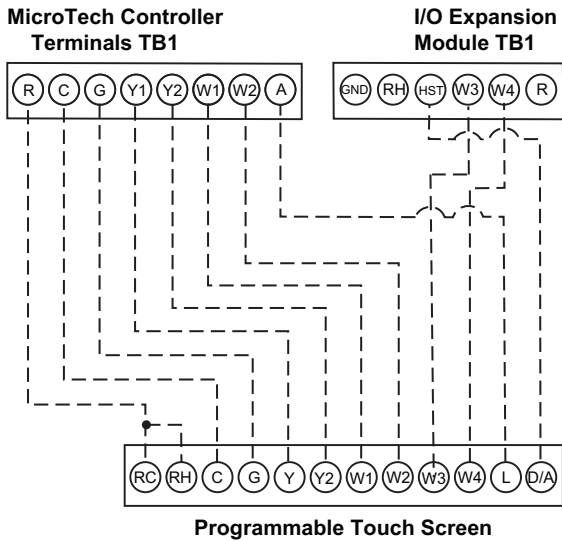

NOTE: I/O Expansion Module Terminal TB1-1 is used for optional dehumidification. I/O Expansion Module Terminal TB1-1 is used for optional WSE operation on a unit with WSE but no dehumidification.

Figure 45: Wiring Example of Typical Heat/Cool Thermostat Connections

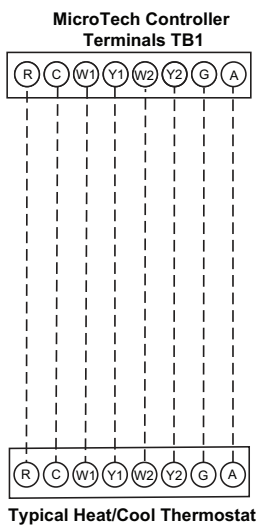

NOTE: For single stage operation, wire Y1 from thermostat to Y2 terminal on the MicroTech control board.

Figure 46: Wiring Example for Three-Stage Thermostat with Waterside Economizer and Hot Gas Reheat. (W4 Connection On MircoTech Controller Should Be Used To Achieve Rated Capacity.)

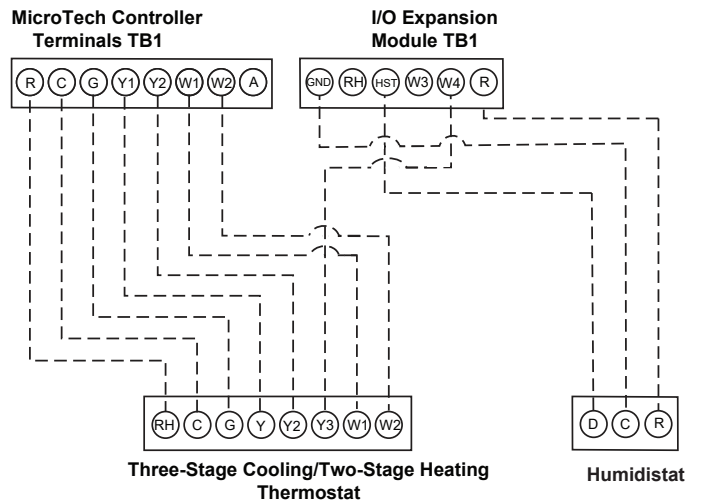

NOTE: For dehumidification with waterside economizer applications, the W4 connection On I/O Expansion Module is used as the third stage of cooling and to achieve rated capacity.

Figure 47: Units Equipped with Dehumidification and Thermostat Control. Factory Supplied Return Air Sensor Connects to I/O H4-3/4 Terminal.

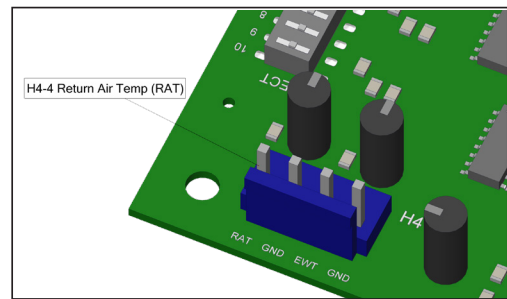

Figure 48: Return Air Temperature Sensor (RAT) Locations

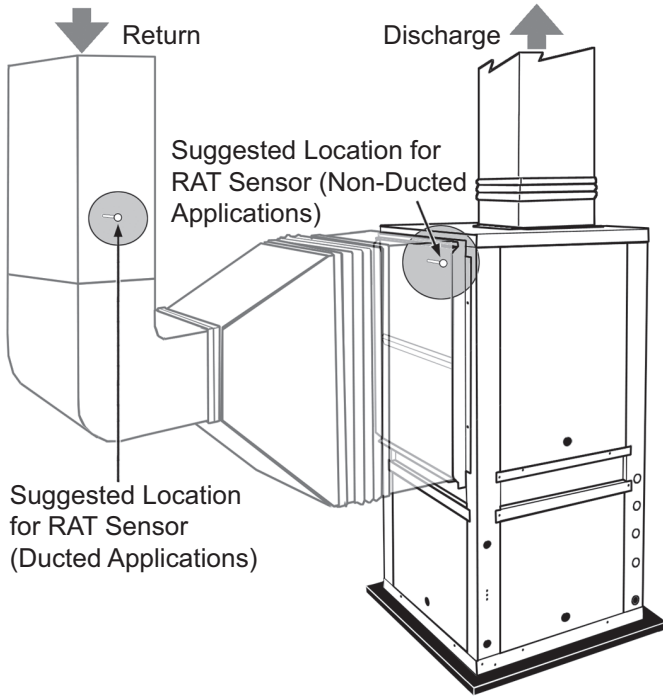
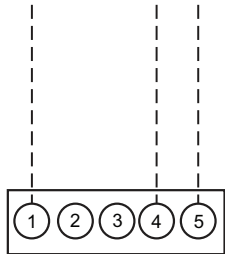

Figure 49: Basic Room Sensor Wiring

MicroTech Controller Terminals TB2



Basic Room Sensor

Figure 50: Example Wiring of SmartSource MicroTech Board to Basic Temperature Sensor Wiring

MicroTech Controller Terminals TB2

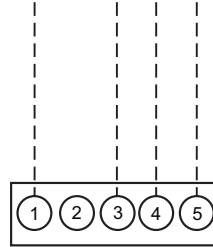
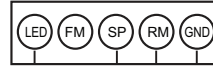

Basic Room Sensor with Cool to Warm Adjustment

Figure 51: Room Sensor with Temperature Adjustment Wiring

MicroTech Controller Terminals TB2

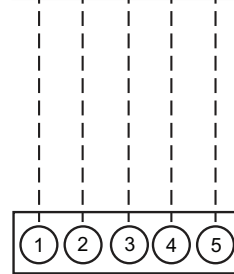
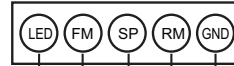

Room Sensor with Temperature Adjustment

Figure 52: Digitally Adjustable Room Temperature Sensor Wiring

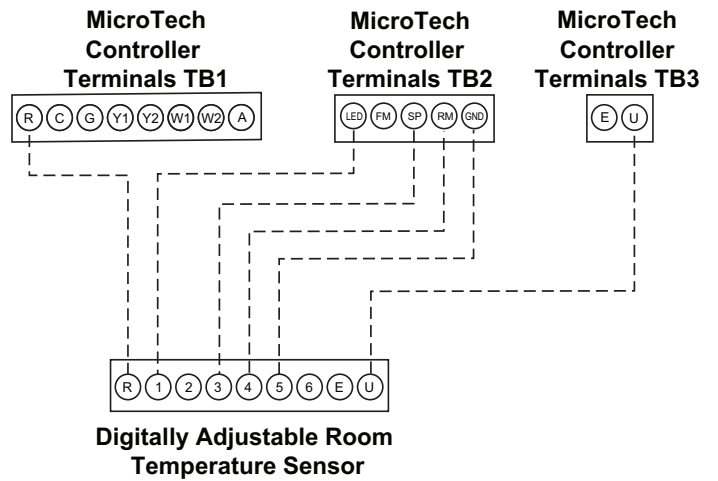
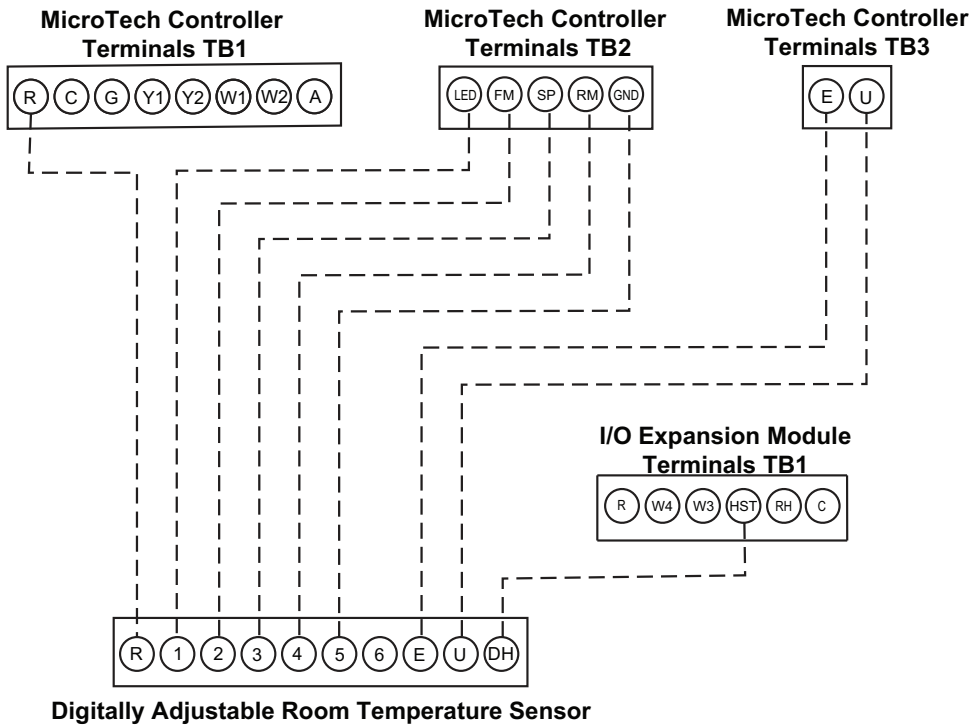
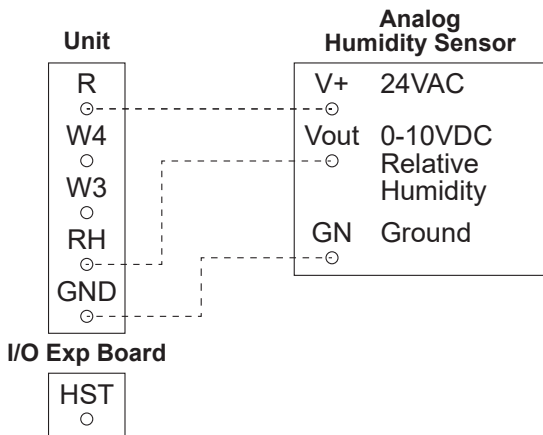

Figure 53: Digitally Adjustable Room Temperature and Humidity Sensor Wiring



NOTE: Terminal TB1-1 is used for optional dehumidification operation.

Figure 54: Analog Humidity Sensor Wiring



NOTE: Analog humidity sensors are intended to be used in conjunction with a building management system to allow monitoring of relative humidity levels and adjustment of relative humidity setpoints for dehumidification. For standalone controller applications, a humidistat is recommended.

Operation

Start-Up

CAUTION

Units must be checked for water leaks upon initial water system start-up. Water leaks may be a result of mishandling or damage during shipping. Failure by the installing contractor to check for leaks upon start-up of the water system could result in property damage.

Check, Test & Start Procedure

NOTICE

Complete the "Water Source Heat Pump Equipment Check, Test and Start Form" on page 66.

MT2300 Board LED Indicator

When the unit controller is communicating a certain fault or mode, the LED indicator will flash a designated pattern or sequence. See Figure 55 for the location of the MT2300 board LED indicator. Table 16 gives a description of the LED activity. Refer to OM 1364 for additional information.

Table 16: MT2300 Board LED Indicator Sequence

LED Activity	Type	Color	Description
1 Flash	Mode	Green	No Call for Heating/Cooling/Dehumidification
2 Flash	Mode	Green	Call for Cooling
3 Flash	Mode	Green	Call for Heating
4 Flash	Mode	Green	Call for Fan Only

Figure 55: LED Indicator on MT2300 Board

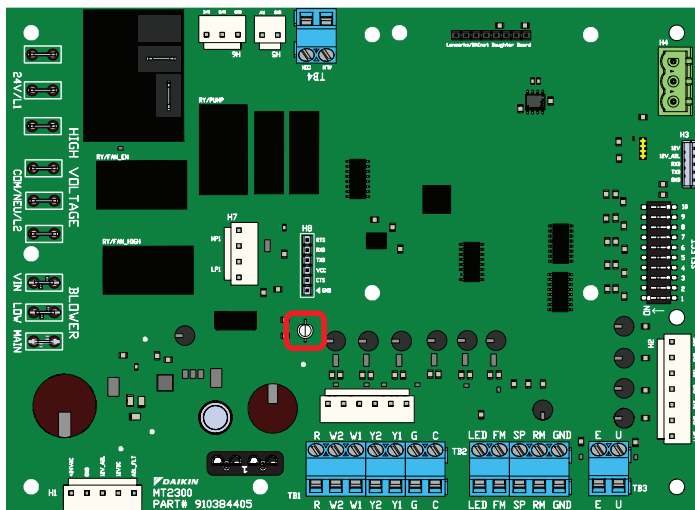

Check as completed:

NOTICE

To prevent compressor cycling and all compressors from starting up together after loss of power, the required minimum on/off time default is 300 seconds plus the random restart of 0 to 60 seconds.

- Open all valves to full open position and turn on power to the unit.
- Set thermostat for "Fan Only" operation by selecting "Off" at the system switch and "On" at the fan switch. If "Auto" fan operation is selected, the fan will cycle with the compressor. Check for proper air delivery.
- Check the unit controller LED indicator for "Fan Only" mode operation.
- Set thermostat to "Cool." If the thermostat is an automatic changeover type, simply set the cooling temperature to the coolest position. On manual changeover types additionally select "Cool" at the system switch.
- Check the unit controller LED indicator for "Cool" mode operation.
- After a few minutes of operation, check the discharge grilles for cool air delivery. To insure proper water flow, measure the temperature difference between entering and leaving water. The temperature differential should be 10°F to 14°F (5°C to 8°C) for units in cooling mode. It should be approximately 1½ times greater than the heating mode temperature difference. For example, if the cooling temperature difference is 15°F (8°C), the heating temperature difference should have been 10°F (5°C).
- Without automatic flow control valves, target a cooling temperature difference of 10°F to 14°F (5°C to 8°C). Adjust the combination shutoff/balancing valve in the return line to a water flow rate which will result in the 10°F to 14°F (5°C to 8°C) difference.
- Set thermostat to "Heat." If the thermostat is the automatic changeover type, set system switch to the "Auto" position and depress the heat setting to the warmest selection. With most control schemes, the fan will start immediately. After a few minutes of compressor operation, check for warm air delivery at discharge grille. If this is a "cold building" start-up, leave unit running until return air to the unit is at least 65°F (18°C).
- Check the unit controller LED indicator for "Heat" mode operation.
- Measure the temperature difference between entering and leaving air and entering and leaving water. With entering water of 60°F to 80°F (16°C to 27°C), leaving water should be 6°F to 12°F (3.3°C to 6.6°C) cooler, and the air temperature rise through the machine should not exceed 35°F (19°C). If the air temperature exceeds 35°F (19°C), then the water flow rate is inadequate.
- Check the elevation and cleanliness of the condensate line. If the air is too dry for sufficient dehumidification, slowly pour enough water into the condensate pan to ensure proper drainage.

- If the unit does not operate, check the following points:
 - Is supply voltage to the machine compatible?
 - Is thermostat type appropriate?
 - Is thermostat wiring correct?
- If the unit operates but stops after a brief period:
 - Is there proper airflow? Check for dirty filter, incorrect fan rotation (3-phase fan motors only), or incorrect ductwork.
 - Is there proper water flow rate within temperature limits? Check water balancing; back flush unit if dirt-clogged.
- Check for vibrating refrigerant piping, fan wheels, etc.

Controls

Table 17: MicroTech 2300 Unit Controller Connector and Terminal Descriptions

Connector	I/O	Type	Signal	Description
H1-1	24 VAC	Power	VAC	Control Power Voltage
H1-2	GND	Power	Ground	Control Power Common
H1-3	12V A2L	Input	VDC	A2L Sense Voltage
H1-4	12 VDC	Output	VDC	A2L Mitigation Voltage
H1-5	A2L FLT	Input	Digital	A2L Fault Alarm
H2-1	LWT	Input	Analog	Leaving Water Temperature
H2-2	GND	REF	Common	
H2-3	DAT	Input	Analog	Discharge Air Temperature
H2-4	GND	REF	Common	
H2-5	ST1	Input	Analog	Comp1 Suction Temperature
H2-6	GND	REF	Common	
H2-7	COF	Input	Analog	Condensate Overflow
H3-1	12 VDC	Output	VDC	Base/Expansion Board Interface
H3-2	12V A2L	Output	VDC	
H3-3	RXD	COM	UART	
H3-4	TXD	COM	UART	
H3-5	GND	COM	UART	
H4-1	B(+)	COM	N/A	Future Use
H4-2	A(-)	COM	N/A	
H4-3	GND	COM	N/A	
H5-1	GND	REF	Common	Comp1 Reversing Valve
H5-2	RV	Output	24 VAC	
H6-1	N/C	Output	24 VAC	Pump Request - Normally Closed Terminal for Normally Open Valves
H6-2	N/O	Output	24 VAC	Pump Request - Normally Open Terminal for Normally Closed Valves
H6-3	GND	REF	Common	Pump Request
H7-1,2	HP1	Input	Digital	Comp1 High Pressure
H7-3,4	LP1	Input	Digital	Comp1 Low Pressure
TB1-1	R	Output	24 VAC	Thermostat 24 VAC Power
TB1-2	W2	Input	24 VAC	Thermostat Heat Stage 2
TB1-3	W1	Input	24 VAC	Thermostat Heat Stage 1
TB1-4	Y2	Input	24 VAC	Thermostat Cool Stage 2
TB1-5	Y1	Input	24 VAC	Thermostat Cool Stage 1
TB1-6	G	Input	24 VAC	Thermostat Fan
TB1-7	C	REF	Common	Thermostat Common
TB2-1	LED	Output	5 VDC	Room Sensor LED
TB2-2	FM	Input	Analog	Room Sensor Fan/Mode
TB2-3	SP	Input	Analog	Room Sensor Setpoint Adjust

Connector	I/O	Type	Signal	Description
TB2-4	RM	Input	Analog	Room Sensor Air Temp / Tenant Override
TB2-5	GND	REF	Common	Room Sensor
TB3-1	E	Input	Digital	Emergency Shutdown
TB3-2	U	Input	Digital	Unoccupied Sensor
TB4-1,2	ALM	Output	Digital	Alarm Output - Contact Closure
BLOWER	VIN	Input	VAC	Blower Motor Voltage
BLOWER	LOW	Output	VIN	Blower Motor Low Speed
BLOWER	MAIN	Output	VIN	Blower Motor High Speed or ECM
LIVE (Relay)	Comp1	Output	L1/24V	Compressor Stage 1
LIVE x 3	24V/L1	Input	VAC	COMP1 Line1 Control Voltage
LIVE x 3	COM/NEU/L2	Input	VAC	COMP1 Line2 Control Voltage
Daughter Board	BACnet	COM	SPI	BACnet MS/TP Only

Table 18: MT2310 I/O Board Connectors and Terminals

Connector	I/O	Type	Signal	Description
H1-1	GND	Power	Ground	Control Power Common
H1-2	24 VAC	Power	VAC	Control Power Voltage
H2-1	GND	REF	Common	Comp2 Suction Temperature
H2-2	ST2	Input	Analog	
H2-3,4	LP2	Input	Digital	Comp2 Low Pressure
H2-5,6	HP2	Input	Digital	Comp2 High Pressure
H3-1	12 VDC	Input	VDC	Base/Expansion Interface
H3-2	12V A2L	Input	VDC	
H3-3	TXD	COM	UART	
H3-4	RXD	COM	UART	
H3-5	GND	REF	Common	
H4-1	GND	REF	Common	Entering Water Temperature
H4-2	EWT	Input	Analog	
H4-3	GND	REF	Common	Return Air Temperature
H4-4	RAT	Input	Analog	
H5-1	GND	REF	Common	Hot Gas Reheat Valve
H5-2	HGR	Output	24 VAC	
H5-3	GND	REF	Common	Waterside Economizer Valve
H5-4	WSE	Output	24 VAC	
H5-5	PWM	Output	PWM	Variable Speed Blower Motor
H6-1	GND	REF	Common	Compressor Stage 2
H6-2	COMP2	Output	24 VAC	
H6-3	GND	REF	Common	Comp2 Reversing Valve
H6-4	RV2	Output	24 VAC	
H6-5	GND	REF	Common	Auxiliary Heat 2
H6-6	AUX2	Output	24 VAC	
H6-7	GND	REF	Common	Auxiliary Heat 1 / Hydronic Heat
H6-8	AUX1	Output	24 VAC	
TB1-1	C	REF	Common	Input Common
TB1-2	RH	Input	Analog	Space Relative Humidity
TB1-3	HST	Input	24VAC	Humidistat
TB1-4	W3	Input	24VAC	Thermostat - Stage 3 Heat
TB1-5	W4	Input	24VAC	Thermostat - Stage 4 Heat or Stage 3 Cool
TB1-6	R	Output	24 VAC	Thermostat - 24 VAC Power

Figure 56: MicroTech2300 Unit Controller and MicroTech 2310 I/O Expansion Board Terminal Location

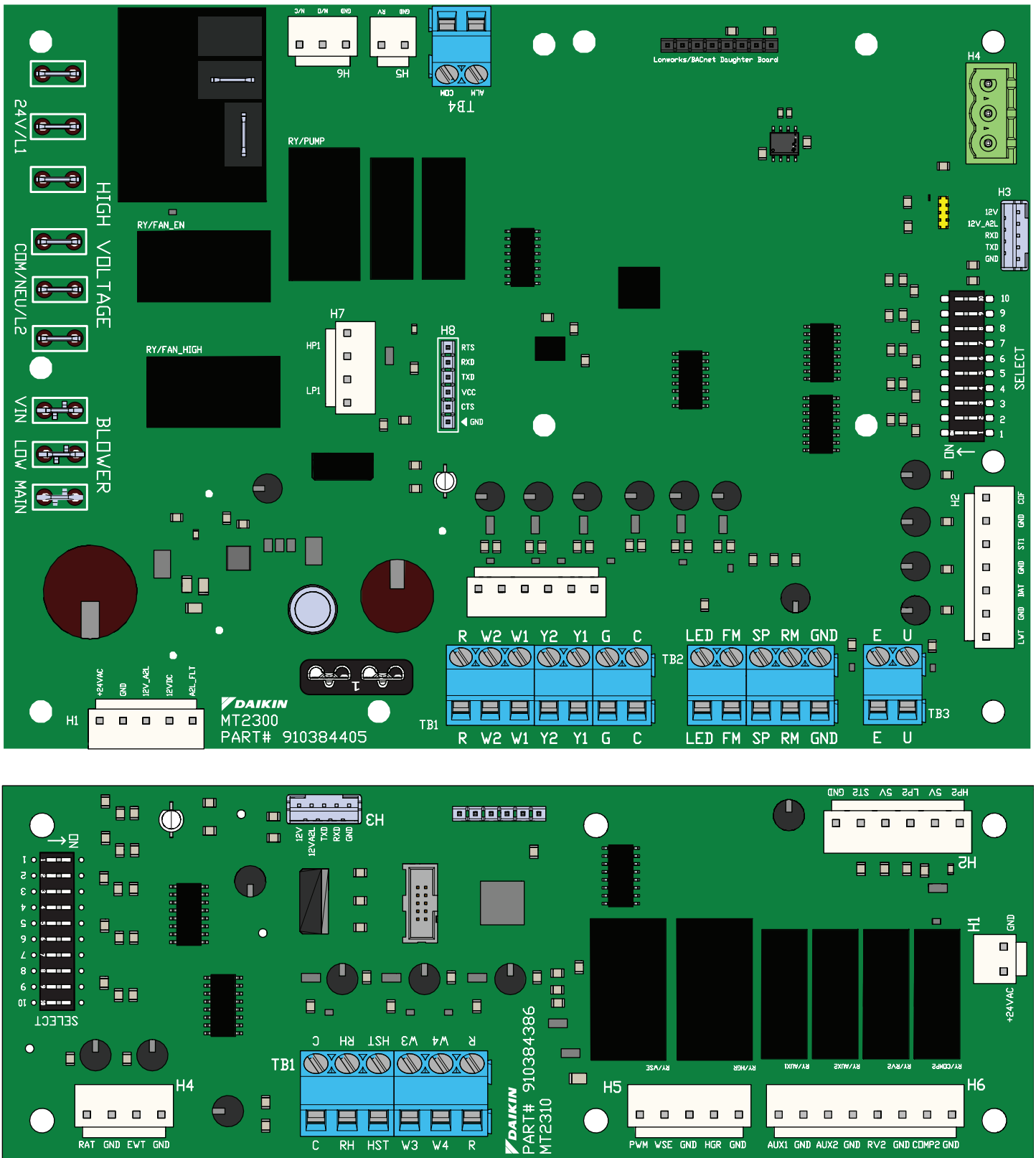

Configuration DIP Switches

WARNING

Proper antifreeze/water solution is required to minimize the potential of fluid freeze-up. DIP switch 3 (SW3) is factory set for water freeze protection with the switch in the OFF position. Operation at fluid temperatures below 32°F (0°C) with anti-freeze protection requires SW3 to be field configured for the switch on. If unit is employing a fresh water system (no anti-freeze protection), it is extremely important that SW3 setting remains in the OFF position (factory default setting) in order to shut down the unit at the appropriate water temperature to protect your heat pump from freezing. Failure to do so can result in unit damage or property damage and will void unit warranty.

Figure 57: Location of Configuration DIP Switches on the MT2300 Unit Controller

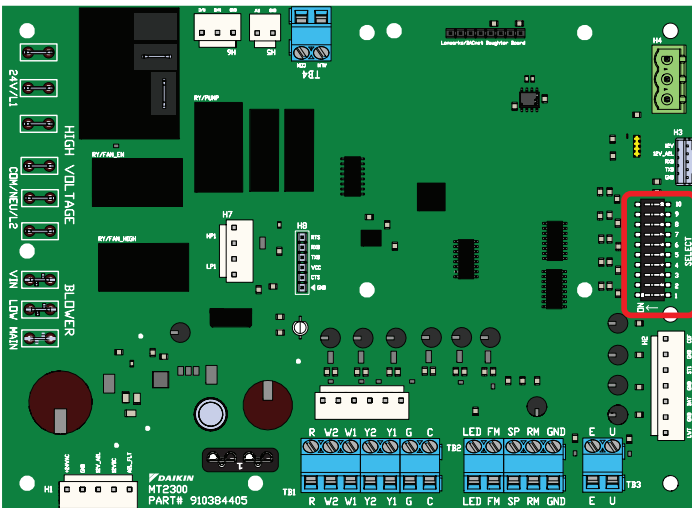

CAUTION

The MT2300 unit controller incorporates static sensitive devices. A static charge from touching the device can damage the electronic components. To help prevent damage during service, use static discharge wrist straps. Static discharge wrist straps are grounded to the heat pump chassis through a 1M ohm resistor.

Table 19: MT2300 Main Board DIP Switch Settings

Switch	Description	Position	Model/Options
SW1	Normal/Test Mode	SW1 = OFF (0)	Normal Operation
		SW1 = ON (1)	Service/Test Mode
SW2	Fan Operation	SW2 = OFF (0)	Continuous Fan Operation (On)
		SW2 = ON (1)	Cycling Fan Operation (Auto)
SW3	Loop Fluid	SW3 = OFF (0)	Water Loop Fluid
		SW3 = ON (1)	Glycol Loop Fluid
SW4	Freeze Fault Detect (FFD)	SW4 = OFF (0)	Disabled FFD
		SW4 = ON (1)	Enabled FFD with LWT sensor installed
SW5	Room Sensor Setpoint Adjust Range	SW5 = OFF (0)	Short Range -5 to +5 F (-2.78 to +2.78 C)
		SW5 = ON (1)	Long Range 55 to 95 F (12.78 to 35 C)

Switch	Description	Position	Model/Options
SW6	Thermostat/Room Sensor Control	SW6 = OFF (0)	Thermostat Control
		SW6 = ON (1)	Room Sensor Control
SW7/SW8	Single Compressor Heating Source	SW7 = OFF (0)	Allow Compressor in Heating Mode
		SW7 = ON (1)	Disable Compressor in Heating Mode
	Single Compressor I/O Expansion Module	SW8 = OFF (0)	I/O Expansion Module Not Required
		SW8 = ON (1)	I/O Expansion Module is Required
	Two Compressor Availability	SW7 = OFF (0) SW8 = OFF (0)	Both Compressors Available (Automatic Compressor Fail Replace)
		SW7 = ON (1) SW8 = OFF (0)	Lead Compressor Available (Lag Compressor is Off-Line)
SW7 = OFF (0) SW8 = ON (1)	No Compressors Available		
SW9	WSHP Base Board Application Select	SW9 = OFF (0)	Single Compressor WSHP Application
		SW9 = ON (1)	Two Compressor Application
SW10	Discrete/Variable Speed Fan Select	SW10 = OFF (0)	Fan Single (Fan Main Output) or Variable (PWM) Speed
		SW10 = ON (1)	Dual Speed Fan (Low & High Discrete Outputs)

NOTE: The functionality of SW7 and SW8 depends on the setting of SW9. If SW9 is OFF, SW7 and SW8 will be for Heating Source and I/O Expansion Module functionality. If SW9 is ON, SW7 and SW8 will be for Compressor Availability functionality.

Figure 58: MT2310 I/O Expansion DIP Switches

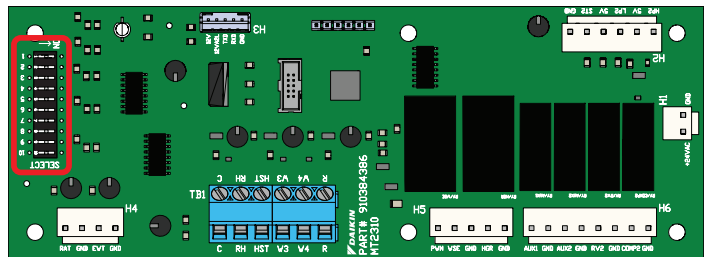

Table 20: MT2310 I/O Expansion Module DIP Switch Settings

Switch	Description	Position	Model/Options
SW1-4	Variable Fan Speed Row Selection	0000 to 1111 Binary	Variable Speed Fan Row Selection (1 to 16), used when "nciVsNetCnfgEn" is set to "Disable" the network override.
SW5/SW6	Secondary Heating Options	SW5 = OFF (0) SW6 = OFF (0)	None
		SW5 = ON (1) SW6 = OFF (0)	Supplemental Electric Heat
		SW5 = OFF (0) SW6 = ON (1)	Boilerless Electric Heat
		SW5 = ON (1) SW6 = ON (1)	Hydronic Heating
SW7	Hot Gas Reheat (HGR)	SW7 = OFF (0)	HGRH Disabled
		SW7 = ON (1)	HGRH Enabled

Switch	Description	Position	Model/Options
SW8	Waterside Economizer (WSE)	SW8 = OFF (0)	Waterside Economizer Disabled
		SW8 = ON (1)	Waterside Economizer Enabled
SW9	WSHP I/O Expansion Application Select	SW9 = OFF (0)	Single Compressor Application
		SW9 = ON (1)	Two Compressor Application
SW10	Single Compressor: Speed	SW10 = OFF (0)	Single Speed Compressor
		SW10 = ON (1)	Dual Speed Compressor
	Two Compressor: Lead Compressor Select	SW10 = OFF (0)	Compressor #1 is Lead
		SW10 = ON (1)	Compressor #2 is Lead

NOTE: The functionality of SW10 depends on the setting of SW9. If SW9 is OFF, SW10 will be for Single Compressor Speed. If SW9 is ON, SW10 will be for Lead Compressor Select.

MicroTech SmartSource Unit Controller

The MicroTech SmartSource unit controller allows thermostat, Daikin Applied sensor and DDC standalone operation. The R (24VAC) terminal is used to operate thermostat inputs G, Y1, Y2, W1, W2, W3, W4 and TB1. The C (common) terminal is used to control inputs U and E. No external power sources may be used to operate the MicroTech controller. All units must be properly grounded per local code requirements.

NOTICE

For information on sequence of operation and troubleshooting refer to OM 1364.

Remote Reset of Automatic Lockouts

The Remote Reset feature provides the means to remotely reset automatic lockouts. There are three (3) ways to accomplish a unit reset once the fault condition has been remedied:

- Using the thermostat, cycle from cool or heat to off and back to heat or cool two times within 30 seconds.
- Press the Room Sensor or Thermostat Timed Override/Reset Button for more than 10 seconds.
- Turn the unit power off and wait 10 seconds to turn back on.

When the cause of the fault condition has been remedied, and the unit is cycled from not requiring heating or cooling to needing heating or cooling twice within 30 seconds (accomplished by user manipulation of the Heat/Cool/ Auto/Off switch on the thermostat), an alarm reset equivalent to a tenant override button reset is generated. The intelligent reset counter and the 24 hour timer are cleared when this type of alarm reset is generated.

NOTICE

This feature only applies to thermostat controlled systems.

For room sensor controlled units, pressing the “Override” or “Reset” button for more than 10 seconds will apply a ground signal to the Room Temperature Sensor connection at TB2 pin 4, RS clearing the lockout alarm once the cause of the fault condition has been remedied.

A unit power cycle can also be used to clear an automatic lockout if the conditions causing the fault have been remedied.

Table 21: MT2300 Unit Controller Status LEDs

LED Activity	Type	Color	Description
Steady ON	Fault	Yellow	MCU Not Programmed
Steady ON	Fault	Red	MCU Hardware Failure
1 Flash	Fault	R–Y–G	Invalid Configuration
2 Flash	Fault	R–Y–G	Incompatible Software
1 Flash	Fault	R–Y	I/O Exp Board Communications Fail
1 Flash	Mode	G–Y	Service / Test Mode Active
Rapid Flash	Fault	Red	A2L Mitigation – Refrigerant Leak
1 Flash	Fault	Red	Compressor #1 High Pressure
2 Flash	Fault	Red	Compressor #1 Low Pressure
3 Flash	Fault	Red	Compressor #1 Suction Temp Sensor Fail
4 Flash	Fault	Red	Compressor #1 Low Suction Temp
5 Flash	Fault	Red	Compressor #2 High Pressure
6 Flash	Fault	Red	Compressor #2 Low Pressure
7 Flash	Fault	Red	Compressor #2 Suction Temp Sensor Fail
8 Flash	Fault	Red	Compressor #2 Low Suction Temp
9 Flash	Fault	Red	A2L Mitigation – Control Board Without Power
10 Flash	Fault	Red	Compressor #1 High Discharge Temp
11 Flash	Fault	Red	Compressor #2 High Discharge Temp
Rapid Flash	Mode	Yellow	A2L Mitigation – Refrigerant Sensor Fail
1 Flash	Fault	Yellow	Compressor Low Voltage Brownout
2 Flash	Fault	Yellow	Freeze Fault Detect (FFD)
3 Flash	Fault	Yellow	Control Temp Sensor Fail
4 Flash	Fault	Yellow	Entering Water Temp Sensor Fail
5 Flash	Fault	Yellow	Leaving Water Temp Sensor Fail
6 Flash	Fault	Yellow	Relative Humidity Sensor Fail
7 Flash	Fault	Yellow	Condensate Overflow
8 Flash	Fault	Yellow	Space Temp Sensor Fail
9 Flash	Fault	Yellow	Return Air Temp Sensor Fail
Rapid Flash	Mode	Green	Emergency Shutdown
1 Flash	Mode	Green	No Call for Heating / Cooling / Dehumidification
2 Flash	Mode	Green	Call for Cooling
3 Flash	Mode	Green	Call for Heating
4 Flash	Mode	Green	Call for Fan Only
5 Flash	Mode	Green	Unoccupied Mode Active
6 Flash	Mode	Green	Call for Dehumidification

LED Activity	Type	Color	Description
7 Flash	Mode	Green	Low Entering Water Temp
8 Flash	Mode	Green	HGR Low Return Air Temp Cutout
9 Flash	Mode	Green	WSE Low Temp Cutout

Table 22: MT2310 I/O Expansion Board Status LEDs

LED Activity	Type	Color	Description
1 Flash	Mode ¹	Green	Variable Speed Fan OFF
2 Flash	Mode ¹	Green	Variable Speed Fan ON: 0 to 20%
3 Flash	Mode ¹	Green	Variable Speed Fan ON: 21 to 30%
4 Flash	Mode ¹	Green	Variable Speed Fan ON: 31 to 40%
5 Flash	Mode ¹	Green	Variable Speed Fan ON: 41 to 50%
6 Flash	Mode ¹	Green	Variable Speed Fan ON: 51 to 60%
7 Flash	Mode ¹	Green	Variable Speed Fan ON: 61 to 70%
8 Flash	Mode ¹	Green	Variable Speed Fan ON: 71 to 80%
9 Flash	Mode ¹	Green	Variable Speed Fan ON: 81 to 90%
10 Flash	Mode ¹	Green	Variable Speed Fan ON: 91 to 100%
Steady ON	Fault	Yellow	MCU Not Programmed
Steady ON	Fault	Red	MCU Hardware Failure
1 Flash	Fault	R-Y-G	Invalid Configuration
2 Flash	Fault	R-Y-G	Incompatible Software
1 Flash	Fault	R-Y	Base Board Communications Failure
Rapid Flash	Fault	Red	A2L Mitigation - Alarm Condition

¹ When the BACnet network is overriding the fan speed DIP switch selection, the LED interval color will be yellow instead of OFF.

Table 23: Priority Level of Faults and Modes with Resets

Alarm Enumeration (BACnet)	Fault	Indication	Reset ¹
1	No Alarm	Normal operation	NA
2	MT2310 Communication Failure	Single compressor unit with SW #8 set to ON position	A
3	Incompatible Software	Incorrect Software Part or Version Numbers	P
4	Invalid Configuration	Base & IO Exp Application Mismatch or MT2310 detected but not required (SW #8)	P
5	A2L Alarm	A2L refrigerant leak detected	A
6	A2L Error - Power	A2L mitigation control is not powered	A
7	Compressor Low Voltage	"Brownout" condition exists	A
8	Comp #1 High Pressure	Compressor #1 high pressure switch opened	T,N
9	Comp #2 High Pressure	Compressor #2 high pressure switch opened	T,N
10	Comp #1 Low Pressure	Compressor #1 low pressure switch opened	T,N
11	Comp #2 Low Pressure	Compressor #2 low pressure switch opened	T,N

Alarm Enumeration (BACnet)	Fault	Indication	Reset ¹
12	Comp #1 Suction Temp Sensor	Compressor #1 suction temp sensor failure	N
13	Comp #2 Suction Temp Sensor	Compressor #2 suction temp sensor failure	N
14	Leaving Water Temp (LWT) Sensor	LWT sensor not present (SW #4 = ON)	N
15	Freeze Fault Detect (FFD)	LWT sensor temp below freeze setpoint (SW #4 = ON)	T,N
16	Comp #1 Low Suction Temp (ST1)	ST1 sensor temp below minimum setpoint	A,T,N ²
17	Comp #2 Low Suction Temp (ST2)	ST2 sensor temp below minimum setpoint	A,T,N ²
18	A2L Error - Sensor	A2L sensor lost communication or reported failure	A
19	Control Temp Sensor Failure	Room Temp and Return Air Temp sensor failures	N
20	Entering Water Temp (EWT) Sensor Failure	EWT sensor reading "out of range"	N
21	Room Temp Sensor Failure	Room temp sensor reading "out of range"	N
22	Return Air Temp Sensor Failure	RAT sensor reading "out of range"	N
23	Space RH Sensor Failure	Space RH sensor reading "out of range"	N
24	Low Entering Water Temp (EWT)	EWT sensor reading below minimum setpoint	A
25	Condensate Overflow	Condensate overflow sensor indicates water present	A,N
26	Waterside Economizer (WSE) Low Temp	WSE temp sensor reading below minimum setpoint	A

NOTE 1: "A" = Auto Reset, "T" = Tenant Override Button Reset, "N" = Network Reset, "P" = power cycle only

NOTE 2: Low suction temperature faults have "Intelligent Reset" logic - 3 faults in a 24 hour period disables the auto reset function.

Table 24: I/O Expansion Module Configuration Switch

Fan Speed Row	Switch 1	Switch 2	Switch 3	Fan Only ¹	Cool Stage 1	Cool Stage 2	Heat Stage 1	Heat Stage 2
1	OFF	OFF	OFF	20%	80%	100%	80%	100%
2	ON	OFF	OFF	20%	70%	90%	70%	90%
3	OFF	ON	OFF	20%	60%	80%	60%	80%
4	ON	ON	OFF	20%	50%	70%	50%	70%
5	OFF	OFF	ON	20%	65%	85%	65%	85%
6	ON	OFF	ON	20%	55%	75%	55%	75%
7	OFF	ON	ON	20%	50%	65%	50%	65%
8	ON	ON	ON	20%	50%	55%	50%	55%

NOTE: When in Fan Only (SW4) mode, OFF = 20% and ON = Cool Stage 1 speed (heat or cool mode fan speeds not affected).

Fan Speed Configuration Switches (SW1, SW2, SW3)

Configuration Switches on the I/O expansion module allow maximum CFM settings to be field adjustable. Fan speed control optimizes unit fan speed (CFM) based on thermostat/room sensor inputs. The fan speed switch allows for manually setting an optimal CFM specific to the application requirements. Each setting on the fan speed configuration switches represents settings 1-4. See Table 19 on page 54 for the complete list of fan speed selector switch settings. Additionally SW3 can be used to reduce the CFM setting. Setting the SW3 to On will reduce the out put signal by 15% of it's maximum value, with a minimum output of 50% of the maximum value while heating, cooling, or dehumidifying.

BACnet Communication Module

On units with an optional BACnet communication module, fan speeds can be set through network communications to 1% resolution of duty cycle. For hydronic or compressorized modes, the range is 50-100%, and for fan only mode, the range is 10-100%. When enabled, the network fan speed settings will override the local configuration switches. When the MT2310 status LED interval is yellow instead of Off, this indicates that the network is overriding the fan speed settings.

Variable CFM

All units have the capability to deliver variable CFM based on the thermostat wiring. By using a multi-stage wall thermostat, the

unit can deliver lower CFM as the space temperature is satisfied. For example, unit size 024 with SW1 and SW2 switches at setting 3 and a 3-stage cooling wall thermostat will deliver 650 CFM at stage 1 cooling, 700 CFM at stage 2 cooling and 800 CFM at stage 3 cooling. All of this is accomplished by wiring the thermostat to the appropriate terminal on the MicroTech controller terminal strip. The variable CFM feature allows for improved humidity levels by increasing latent cooling capacity through reduced CFM. Here, we are attempting to satisfy cooling at the lowest airflow, 650 CFM, but having the capability to deliver higher airflow, 800 CFM, if needed.

Fan Only Speed Configuration Switch (SW4)

In addition to the SW1, SW2, and SW3 switches, all units have the capability to set Fan Only CFM values independent to those associated with other modes of operation using the SW4 switch. When the SW4 switch is Off the fan only speed will be fixed at the speed associated with a low 20% duty cycle output. When the SW4 switch is On, the Fan Only speed will match the speed for the Stage 1/Low CFM output.

For example, unit size 036 with SW1 and SW2 switches set at Setting #3, SW3 set at Off, and SW4 set at On, will deliver 1200 CFM at stage 2 compressor operation mode, 1050 CFM at stage 1 compressor operation, 1350 CFM in electric heat mode, 1050 CFM in fan only mode, 975 CFM in dehumidification mode, 1050 CFM in hydronic heat mode, and 1050 CFM in waterside economizer mode.

Figure 59: SW1 & SW2 Location on The I/O Expansion Module

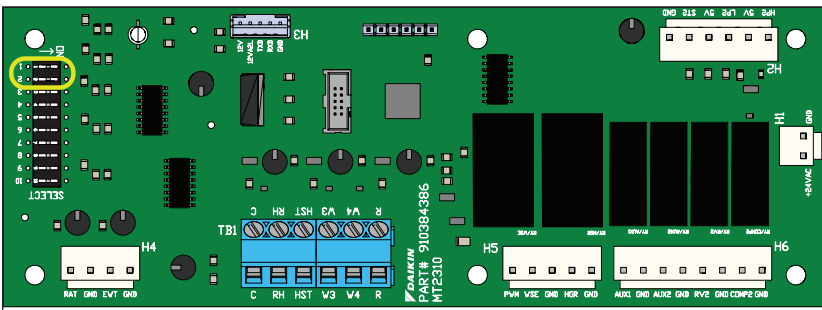

Table 25: Representative Data for Size 036, Constant CFM

Unit Size	Fan Setting	Maximum ESP (in. wg.) ²	¹ Low CFM Heat	¹ High CFM Heat	¹ Low CFM Cool	¹ High CFM Cool	Dehumidification	Electric Heat	Fan Only SW4 On	Fan Only SW4 Off	Hydronic Heat	Waterside Economizer
036	Fan Speed 1	0.7	1200	1350	1200	1350	1125	1350	1200	750	1200	1200
	Fan Speed 2		1125	1275	1125	1275	1050	1350	1125	750	1125	1125
	Fan Speed 3		1050	1200	1050	1200	975	1350	1050	750	1050	1050
	Fan Speed 4		975	1125	975	1125	975	1350	975	750	975	975
	Fan Speed 5		1088	1238	1088	1238	1013	1350	1088	750	1088	1088
	Fan Speed 6		1013	1163	1013	1163	975	1350	1013	750	1013	1013
	Fan Speed 7		975	1088	975	1088	975	1350	975	750	975	975
	Fan Speed 8		975	1013	975	1013	975	1350	975	750	975	975

¹ The unit is capable of high-low fan performance through the use of a 2-stage thermostat wired to specific terminals for High-Low CFM fan performance. Standard operation with a 1-stage thermostat is indicated as High CFM fan performance.

² Applications up to 1.0" ESP (in. wg.) are possible. However, increased fan noise should be anticipated and appropriate noise attenuation should be considered.

MT2300 Controller with an Optional BACnet® Communication Module



For installation and operation information on MT2300 unit controller and other ancillary components, see:

- OM 1364 - MT2300 Unit Controller with MT2310 I/O Expansion Board MicroTech® Controller
- IM 955 - MicroTech Wall Sensor For Use with Microtech SmartSource Unit Controller
- IM 956 - Temperature Sensors for Units with MicroTech®III or MT2300 Unit Controller and LonWorks® or BACnet® Communication Module
- IM 1363 - MicroTech MT2300 Water Source Heat Pump Unit Controller BACnet® MS/TP Communication Module
- ED 19129 - MicroTech MT2300 Water Source Heat Pump Unit Controller BACnet® Protocol Information

Daikin Applied water source heat pumps are available with an optional BACnet MS/TP communication module that is designed to communicate over a BACnet MS/TP communications network to a building automation system (BAS). It can be factory or field-installed.

The unit controller is programmed and tested with all the logic required to monitor and control the unit. An optional wall sensor may be used with the communication module to provide limited local control of the water source heat pump. The unit controller monitors water and air temperatures and passes information to the communication module. The module communicates with the BAS, to provide network control of the water source heat pump.

The module makes operational data and commands available on a communications network using BACnet objects and properties:

- The network cable is a shielded twisted-pair cable
- Network communications run up to 76.8 Kbps
- DIP switches on the controller enable the MS/TP MAC address to be set in the range 0-127
- Four green status LEDs on the communication module indicate communication activity on the MS/TP communication network and with the unit controller

MT2300 Unit Controller with BACnet MS/TP Communication Module Orchestrates the Following Unit Operations

- Enable heating and cooling to maintain setpoint based on a room sensor
- Enable fan and compressor operation
- Monitors all equipment protection controls
- Monitors room and discharge air temperatures
- Monitors leaving water temperature
- Relays status of all vital unit functions

The MT2300 Unit Controller with an Optional Communication Module Includes

- Return Air Temperature sensor (RAT) (field-installed)
- Discharge Air Temperature sensor (DAT) (field-installed)
- Leaving Water Temperature sensor (LWT)

NOTICE

Refer to IM 956 for details to install RAT & DAT sensors.

The communication module provides access to setpoints for operational control.

Available wall sensors include:

- Room sensor with LED status and tenant override button
- Room sensor with LED status, tenant override button, and $\pm 5^{\circ}\text{F}$ setpoint adjustment
- Room sensor with LED status, tenant override button, 55° to 95°F (13° to 35°C) setpoint adjustment

Maintenance

1. Normal maintenance on all units is generally limited to filter changes. Units are provided with permanently lubricated motors and require no oiling even though oil caps may be provided.
2. Filter changes are required at regular intervals. The time period between changes will depend upon the project requirements. Some applications such as motels produce a lot of lint from carpeting and linen changes, and will require more frequent filter changes. Check filters at 60-day intervals for the first year until experience is acquired. If light cannot be seen through the filter when held up to sunlight or a bright light, it should be changed. A more critical standard may be desirable.
3. The condensate drain pan should be checked annually and

- cleaned and flushed as required.
4. Record performance measurements of volts, amps, and water temperature differences (both heating and cooling). A comparison of logged data with start-up and other annual data is useful as an indicator of general equipment condition.
5. Periodic lockouts almost always are caused by air or water problems. The lockout (shutdown) of the unit is a normal protective result. Check for dirt in the water system, water flow rates, water temperatures, airflow rates (may be a dirty filter), and air temperatures. If the lockout occurs in the morning following a return from night setback, entering air below machine limits may be the cause.
6. Should motor replacement become necessary in the future, refer to [Figure 60](#) for the motor removal process.

Figure 60: Disassemble Motor Orifice Ring and Motor Mount Screws From Fan Housing

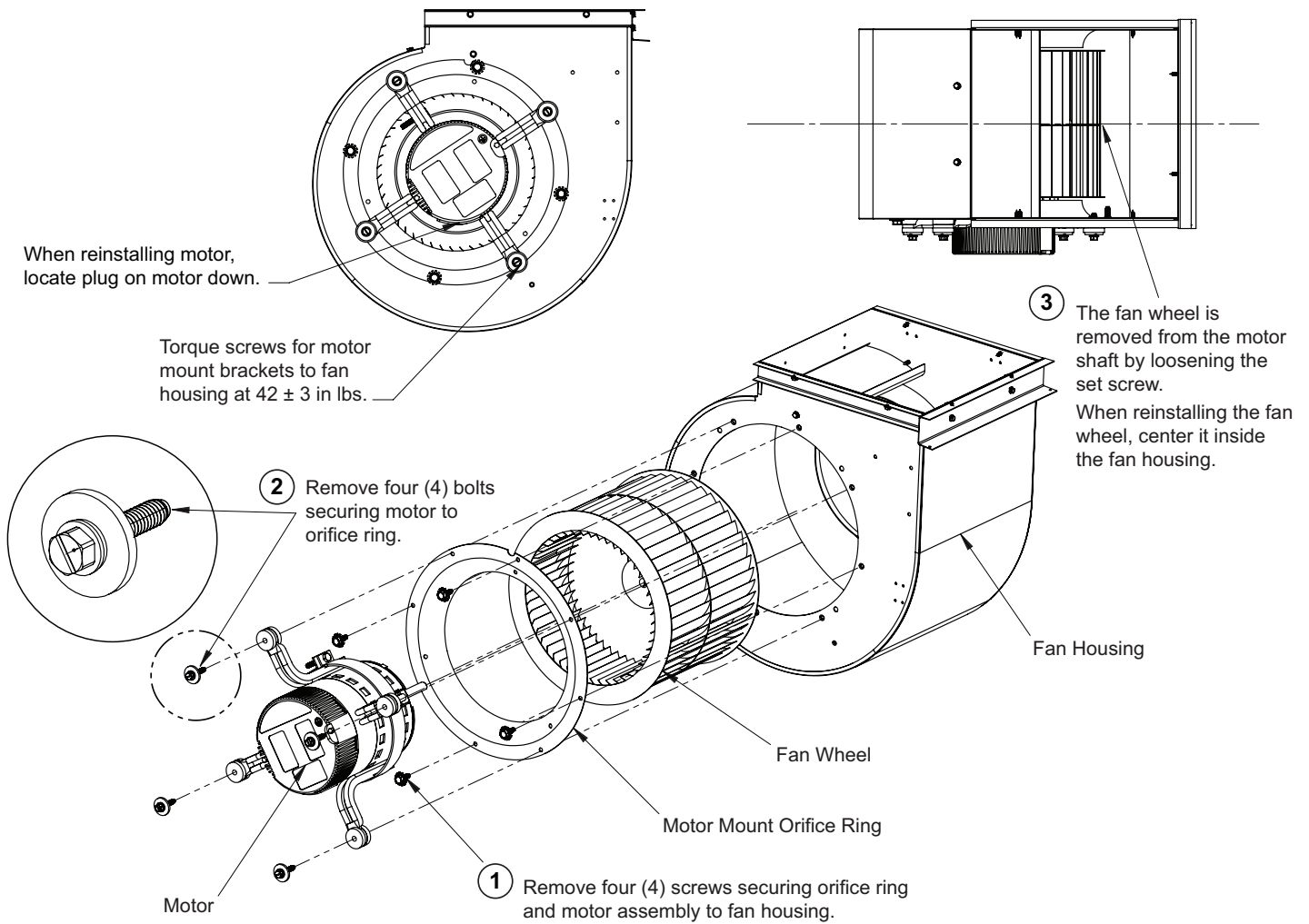

Troubleshooting

Table 26: Troubleshooting Refrigeration Circuit

Symptom	Head Pressure	Suction Pressure	Compressor Amp Draw	Super Heat	Subcooling	Air Temp Differential	Water (Loops) Temp Differential	Safety Lock Out
Undercharge System (Possible Leak)	Low	Low	Low	High	Low	Low	Low	Low Pressure
Overcharge System	High	High	High	Normal	High	Normal/Low	Normal	High Pressure
Low Air Flow Heating	High	High	High	High/Normal	Low	High	Low	High Pressure
Low Air Flow Cooling	Low	Low	Low	Low/Normal	High	High	Low	Low Temp
Low Water Flow Heating	Low/Normal	Low/Normal	Low	Low	High	Low	High	Low Temp
Low Water Flow Cooling	High	High	High	High	Low	Low	High	High Pressure
High Air Flow Heating	Low	Low	Low	Low	High	Low	Low	Low Temp
High Air Flow Cooling	Low	High	Normal	High	Low	Low	Normal	High Pressure
High Water Flow Heating	Normal	Low	Normal	High	Normal	Normal	Low	High Pressure
High Water Flow Cooling	Low	Low	Low	Low	High	Normal	Low	Low Temp
TXV Restricted	High	Low	Normal/Low	High	High	Low	Low	Low Temp/High Pressure

Troubleshooting the Water Source Heat Pump Unit

Compressor runs in short cycle

- Check wiring - loose or broken and check for faulty connection.
- Check relays and contacts, also capacitor and wiring.
- Check high pressure switch, low pressure switch and low temperature switch to see if unit is cycling on the safety.
- Check to see if the reversing valve is not hung up and is operating correctly.
- Check condensate overflow switch in cool/dehumidification mode of operation.
- Check thermostat or room sensor for proper location.

Neither fan, nor compressor runs and all LED lights are off

- Unit control, check thermostat for correct wiring or faulty thermostat.
- Wire may be loose or broken. Replace or tighten wires.
- Fuse may be blown, circuit breaker is open.
- Low voltage, check power supply voltage.

Fan operates, compressor does not

- Check wiring - loose or broken and check for bad connection.
- High or Low pressure lockout:
 - a. Cool mode, check water flow.
 - b. Heating mode, check air flow.
 - c. Check reversing valve for proper valve position.

- Check compressor overload - make sure it is closed.
- Check compressor to ground, or for internal short to ground.
- Compressor winding may be open. Check continuity with ohm meter.

Compressor attempts to start but does not



- Check compressor wiring for defective wiring or loose connection.
- Check for defective compressor internal windings with ohm meter.
- Check for faulty compressor capacitor.
- Check for lock rotor amp draw.

Insufficient cooling or heating

- Check thermostat for improper location.
- Check for proper air flow - filter could be dirty.
- Check blower assembly for dirt or faulty fan motor capacity.
- Check for low refrigerant charge.
- Check amp draw on blower assembly.
- Check for proper water flow and delta T (°F).

Refrigerant Information

Refrigerant Guidelines

 WARNING	
	<p>This unit contains R-32, a class A2L refrigerant that is flammable. This unit should only be installed, serviced, repaired, and disposed of by qualified personnel licensed or certified in their jurisdiction to work with R-32 refrigerant. Installation and maintenance must be done in accordance with this manual. Improper handling of this equipment can cause equipment damage or personal injury.</p>
<p>For installation only in locations not accessible to the general public.</p> <p>Be aware that R-32 refrigerant may not contain an odor. Place in a well ventilated area to prevent accumulation of refrigerant. When installing the unit in a small room, take measures to keep the refrigerant concentration from exceeding allowable safety limits. Excessive refrigerant leaks, in the event of an accident in a closed ambient space, can lead to oxygen deficiency.</p> <p>Do not pierce or burn this unit.</p> <p>Never use an open flame during service or repair. Never store in a room with continuously operating ignition sources (for example: open flames, an operating gas appliance, or an operating electric heater.), where there is ignitable dust suspension in the air, or where volatile flammables such as thinner or gasoline are handled.</p> <p>Only use pipes, nuts, and tools intended for exclusive use with R-32 refrigerant in compliance with national codes (ASHRAE15 or IRC).</p> <p>Do not mix air or gas other than R-32 in the refrigerant system. If air enters the refrigerant system, an excessively high pressure results, which may cause equipment damage or injury.</p> <p>Do not use means to accelerate the defrosting process or to clean, other than those recommended by the manufacturer.</p>	

Lubrication

R-32 should be used only with polyolester (POE) oil. The HFC refrigerant components in R-32 will not be compatible with mineral oil or alkylbenzene lubricants. R-32 systems will be charged with the OEM recommended lubricant, ready for use with R-32.

Competence of Personnel

Information of procedures additional to usual information for refrigerating equipment installation, repair, maintenance and decommission procedures is required when equipment with flammable refrigerants is affected.

The training of these procedures is carried out by national training organizations or manufacturers that are accredited to teach the relevant national competency standards that may be set in legislation. The achieved competence should be documented by a certificate.

WARNING

Service on this equipment is to be performed by qualified refrigeration personnel familiar with equipment operation, maintenance, correct servicing procedures, and the safety hazards inherent in this work. Causes for repeated tripping of equipment protection controls must be investigated and corrected. Disconnect all power before doing any service inside the unit. If refrigerant leaks from the unit, there is a potential danger of suffocation since refrigerant will displace the air in the immediate area. Servicing this equipment must comply with the requirements of all applicable industry related published standards and local, state and federal, statutes, regulations and codes in regards to refrigerant reclamation and venting. Avoid exposing refrigerant to an open flame or other ignition source.

Maintaining and servicing R-32 refrigerant should only be performed as recommended by this manual and by personnel licensed or certified in their jurisdiction to handle A2L refrigerants. Dismantling the unit and treatment of the refrigerant, oil, and additional parts must be done in accordance with the relevant local, state, and national regulations.

Only use tools meant for use on R-32 refrigerant, such as a gauge manifold, charge hose, gas leak detector, reverse flow check valve, refrigerant charge base, vacuum gauge, or refrigerant recovery equipment.

The following guidelines align with UL Standard 60335-2-40.

Maintenance and Repair

- Portable equipment shall be repaired outside or in a workshop specially equipped for servicing units with **FLAMMABLE REFRIGERANTS**.
- Ensure sufficient ventilation at the repair place.
- Be aware that malfunction of the equipment may be caused by refrigerant loss and a refrigerant leak is possible.
- Discharge capacitors in a way that won't cause any spark. The standard procedure to short circuit the capacitor terminals usually creates sparks.
- When brazing is required, the following procedures shall be carried out in the right order:
 - Remove the refrigerant. If the recovery is not required by national regulations, drain the refrigerant to the outside. Take care that the drained refrigerant will not cause any danger. In doubt, one person should guard the outlet. Take special care that drained refrigerant will not float back into the building.
 - Evacuate the refrigerant circuit.
 - Remove parts to be replaced by cutting, not by flame.
 - Purge the braze point with nitrogen during the brazing procedure.
 - Carry out a leak test before charging with refrigerant.
- Reassemble sealed enclosures accurately. If seals are worn, replace them.
- Check safety equipment before putting into service.

Checks to the refrigerating equipment

Where electrical components are being changed, they shall be fit for the purpose and to the correct specification. At all times

the manufacturer's maintenance and service guidelines shall be followed. If in doubt, consult the manufacturer's technical department for assistance.

The following checks shall be applied to installations using FLAMMABLE REFRIGERANTS:

- the actual REFRIGERANT CHARGE is in accordance with the room size within which the refrigerant containing parts are installed;
- the ventilation machinery and outlets are operating adequately and are not obstructed;
- if an indirect refrigerating circuit is being used, the secondary circuit shall be checked for the presence of refrigerant;
- marking to the equipment continues to be visible and legible. Markings that are illegible shall be corrected; and
- refrigerating pipe or components are installed in a position where they are unlikely to be exposed to any substance which may corrode refrigerant containing components, unless the components are constructed of materials which are inherently resistant to being corroded or are suitably protected against being so corroded.

Checks to electrical devices

Repair and maintenance to electrical components shall include initial safety checks and component inspection procedures. If a fault exists that could compromise safety, then no electrical supply shall be connected to the circuit until it is satisfactorily dealt with. If the fault cannot be corrected immediately but it is necessary to continue operation, an adequate temporary solution shall be used. This shall be reported to the owner of the equipment so all parties are advised.

Initial safety checks shall include:

- that capacitors are discharged: this shall be done in a safe manner to avoid possibility of sparking;
- that no live electrical components and wiring are exposed while charging, recovering or purging the system; and
- that there is continuity of earth bonding.

Sealed electrical and intrinsically safe components

- All sealed electrical components shall be replaced.
- All intrinsically safe components must be replaced.

Cabling

- Check that cabling will not be subject to wear, corrosion, excessive pressure, vibration, sharp edges or any other adverse environmental effects. The check shall also take into account the effects of aging or continual vibration from sources such as compressors or fans.

Leak Detection

Under no circumstances shall potential sources of ignition be used in the searching for or detection of refrigerant leaks. NEVER use the following when attempting to detect flammable refrigerant leaks:

- A halide torch (or any other detector using a naked flame)

- Substances containing chlorine

Detection of flammable refrigerants

The following leak detection methods are deemed acceptable for all refrigerant systems:

- Electronic leak detectors may be used to detect refrigerant leaks. For FLAMMABLE REFRIGERANTS, the sensitivity of electronic leak detectors may not be adequate, or may need re-calibration. (Detection equipment shall be calibrated in a refrigerant-free area.) Ensure that the detector is not a potential source of ignition and is suitable for the refrigerant used. Leak detection equipment shall be set at a percentage of the LFL of the refrigerant and shall be calibrated to the refrigerant employed, and the appropriate percentage of gas (25 % maximum) is confirmed.
- Leak detection fluids are also suitable for use with most refrigerants but the use of detergents containing chlorine shall be avoided as the chlorine may react with the refrigerant and corrode the copper pipe-work. Examples of leak detection fluids are:
 - bubble method; or
 - fluorescent method agents.
- If a leak is suspected, all open flames shall be removed/ extinguished.
- If a leakage of refrigerant is found which requires brazing, all of the refrigerant shall be recovered from the system, or isolated (by means of shut off valves) in a part of the system remote from the leak. Removal of refrigerant shall be according to instructions in "[Pressure Testing and Refrigerant Evacuation](#)".

Pressure Testing and Refrigerant Evacuation

- Make sure that air or any matter other than R-32 refrigerant does not get into the refrigeration cycle.
- If refrigerant gas leaks occur, ventilate the room/area as soon as possible.
- R-32 should always be recovered and never released directly into the environment.
- Only use tools meant for use on R-32 refrigerant (such as a gauge manifold, charging hose, or vacuum pump adapter).

Removal and evacuation

When breaking into the refrigerant circuit to make repairs, or for any other purpose, conventional procedures shall be used. However, for flammable refrigerants it is important that best practice be followed, since flammability is a consideration.

- The following procedure shall be adhered to:
 - safely remove refrigerant following local and national regulations - see "[Recovery](#)" section;
 - purge the circuit with inert gas;
 - evacuate;
 - purge with inert gas;
 - open the circuit by cutting (if flammable refrigerant) or brazing.

- The refrigerant charge shall be recovered into the correct recovery cylinders according to local and national codes. For equipment containing flammable refrigerants, the system shall be purged with oxygen-free nitrogen to render the equipment safe for flammable refrigerants. This process might need to be repeated several times.
- Compressed air or oxygen shall not be used for purging refrigerant systems.
- For equipment containing flammable refrigerants, refrigerants purging shall be achieved by breaking the vacuum in the system with oxygen-free nitrogen and continuing to fill until the working pressure is achieved, then venting to atmosphere, and finally pulling down to a vacuum.
- When the final oxygen-free nitrogen charge is used, the system shall be vented down to atmospheric pressure to enable work to take place.
- Ensure that the outlet for the vacuum pump is not close to any potential ignition sources and that ventilation is available.

Handling and Storage

Conditions for safe storage

- Requirements to be met by storerooms and receptacles:
 - Store only in unopened original receptacles
 - Store in a cool and dry location
- Further information about storage conditions:
 - Keep container tightly sealed
 - Store in cool, dry conditions in well sealed receptacle
 - Protect from heat and direct sunlight
- Maximum storage temperature: 40°C (104°F)

Fire and explosion protection information

Open and handle refrigerant receptacle with care. Keep ignition sources away. Do not smoke. Protect against electrostatic charges. Waste air is to be released into the atmosphere only via suitable separators.

Commissioning

- Ensure that the floor area is sufficient for the refrigerant charge or that the ventilation duct is assembled in a correct manner.
- Connect the pipes and carry out a leak test before charging with refrigerant.
- Check safety equipment before putting into service.

Charging procedures

In addition to conventional charging procedures and specific unit charging guidelines, the following requirements shall be followed:

- Ensure that contamination of different refrigerants does not occur when using charging equipment.
- Hoses or lines shall be as short as possible to minimize the amount of refrigerant contained in them.

- Cylinders shall be kept in an appropriate position according to the instructions.
- Ensure that the refrigerating system is earthed prior to charging the system with refrigerant.
- Label the system when charging is complete (if not already).
- Extreme care shall be taken not to overfill the refrigerating system.
- Prior to recharging the system, it shall be pressure-tested with the appropriate purging gas. The system shall be leak-tested on completion of charging but prior to commissioning. A follow up leak test shall be carried out prior to leaving the site.

Decommissioning

- If the safety is affected when the equipment is put out of service, the refrigerant charge shall be removed before decommissioning.
- Ensure sufficient ventilation at the equipment location.
- Be aware that malfunction of the equipment may be caused by refrigerant loss and a refrigerant leak is possible.
- Discharge capacitors in a way that won't cause any spark.
- Remove the refrigerant according to details in "Recovery" section. If recovery is not required by national regulations, drain the refrigerant to the outside. Take care that the drained refrigerant will not cause any danger. In doubt, one person should guard the outlet. Take special care that drained refrigerant will not float back into the building.
- Ensure all isolation valves on the equipment are closed off.

Labeling

Equipment shall be labeled stating that it has been decommissioned and emptied of refrigerant. The label shall be dated and signed. For equipment containing FLAMMABLE REFRIGERANTS, ensure that there are labels on the equipment stating the equipment contains FLAMMABLE REFRIGERANT.

Recovery

When removing refrigerant from a system, either for servicing or decommissioning, it is recommended good practice that all refrigerants are removed safely. When transferring refrigerant into cylinders, ensure that only appropriate refrigerant recovery cylinders are employed. Ensure that the correct number of cylinders for holding the total system charge is available. All cylinders to be used are designated for the recovered refrigerant and labeled for that refrigerant (i.e., special cylinders for the recovery of refrigerant). Cylinders shall be complete with pressure-relief valve and associated shut-off valves in good working order. Empty recovery cylinders are evacuated and, if possible, cooled before recovery occurs.

The recovery equipment shall be in good working order with a set of instructions concerning the equipment that is at hand and shall be suitable for the recovery of all appropriate refrigerants including, when applicable, FLAMMABLE REFRIGERANTS. If in doubt, the manufacturer should be consulted. In addition, a set of calibrated weighing scales shall be available and in good working order. Hoses shall be complete with leak-free

disconnect couplings and in good condition. Before using the recovery machine, check that it is in satisfactory working order, has been properly maintained and that any associated electrical components are sealed to prevent ignition in the event of a refrigerant release. Consult manufacturer if in doubt.

The recovered refrigerant shall be returned to the refrigerant supplier in the correct recovery cylinder, and the relevant waste transfer note arranged. Do not mix refrigerants in recovery units and especially not in cylinders.

If compressors or compressor oils are to be removed, ensure that they have been evacuated to an acceptable level to make certain that FLAMMABLE REFRIGERANT does not remain within the lubricant. The evacuation process shall be carried out prior to returning the compressor to the suppliers. Only electric heating to the compressor body shall be employed to accelerate this process. When oil is drained from a system, it shall be carried out safely.

Recovery procedure

Before carrying out this procedure, it is essential that the technician is completely familiar with the equipment and all its detail. It is recommended good practice that all refrigerants are recovered safely.

Prior to the task being carried out, an oil and refrigerant sample shall be taken in case analysis is required prior to re-use of recovered refrigerant.

It is essential that electrical power is available before the task is commenced.

1. Become familiar with the equipment and its operation.
2. Isolate system electrically.
3. Before attempting the procedure, ensure that
 - mechanical handling equipment is available, if required, for handling refrigerant cylinders;
 - all personal protective equipment is available and being used correctly;
 - the recovery process is supervised at all times by a competent person;
 - recovery equipment and cylinders conform to the appropriate standards.
4. Pump down refrigerant system, if possible.
5. If a vacuum is not possible, make a manifold so that refrigerant can be removed from various parts of the system.
6. Make sure that cylinder is situated on the scale before recovery takes place.
7. Start the recovery machine and operate in accordance with instructions.
8. Do not overfill cylinders (no more than 80% volume liquid charge).
9. Do not exceed the maximum working pressure of the cylinder, even temporarily.
10. When the cylinders have been filled correctly and the process completed, make sure that the cylinders and the equipment are removed from site promptly and all isolation valves on the equipment are closed off.

Disposal

- Waste treatment method recommendation:
 - Must be specially treated adhering to official regulations
 - Incineration in an adequate incinerator is recommended
 - Uncleaned packaging disposal must be made according to official regulations
- Ensure sufficient ventilation at the working place
- The following procedure shall be adhered to:
 - i. safely remove refrigerant following local and national regulations - see "Recovery" section;
 - ii. evacuate the refrigerant circuit;
 - iii. purge the refrigerant circuit with nitrogen gas for 5 minutes;
 - iv. evacuate again; and
 - v. If compressors are to be removed, cut out the compressor and drain the oil.

Typical Refrigeration Cycles

Cooling Refrigeration Cycle

When the wall thermostat is calling for COOLING, the reversing valve is de-energized and directs the flow of the refrigerant (hot gas) leaving the compressor to the water-to-refrigerant heat exchanger. Here the heat is removed by the water and the hot gas condenses to become a liquid. The liquid then flows through a thermal expansion valve (TXV) and then to the air-to-refrigerant heat exchanger coil. The liquid then evaporates becoming a gas, at the same time absorbing heat and cooling the air passing over the surfaces of the coil. The refrigerant then flows as a low pressure gas through the reversing valve and back to the suction side of the compressor to complete the cycle.

Heating Refrigeration Cycle

When the wall thermostat is calling for HEATING, the reversing valve is energized and directs the flow of the refrigerant (hot gas) leaving the compressor to the air-to-refrigerant heat exchanger coil. Here the heat is removed by the air passing over the surfaces of the coil and the hot gas condenses to become a liquid. The liquid then flows through a TXV then to the water-to-refrigerant heat exchanger. The liquid then evaporates becoming a gas, at the same time absorbing heat and cooling the water. The refrigerant then flows as a low pressure gas through the reversing valve and back to the suction side of the compressor.

Figure 61: Cooling Mode

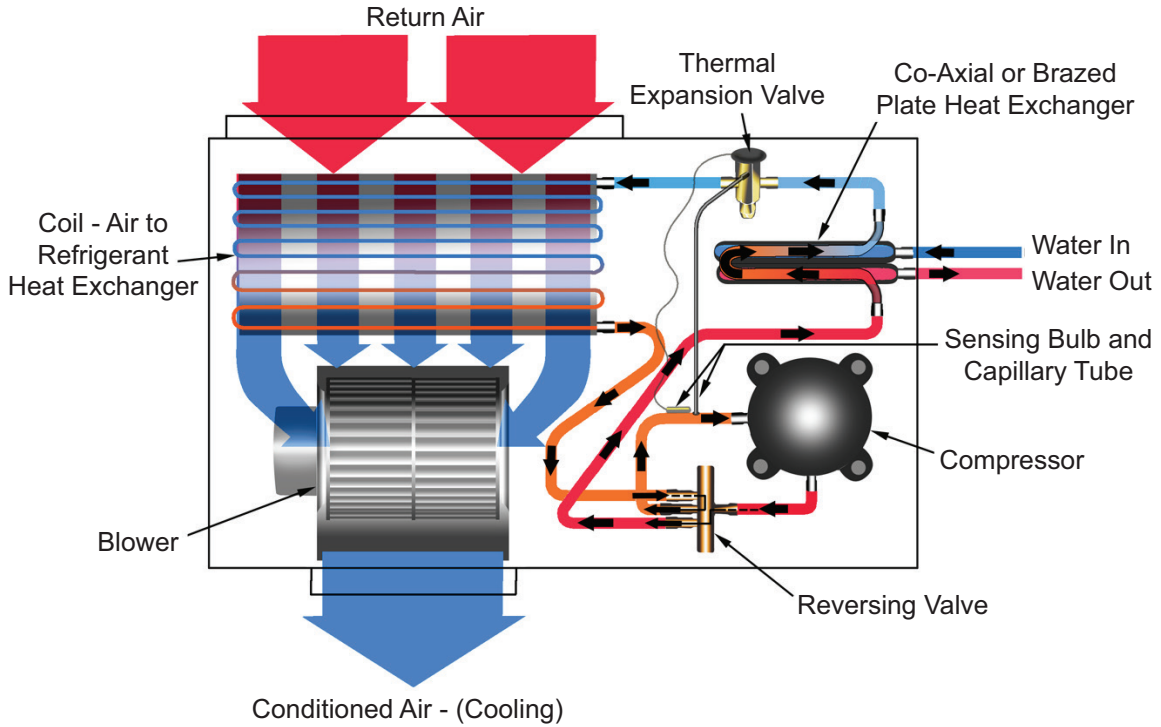
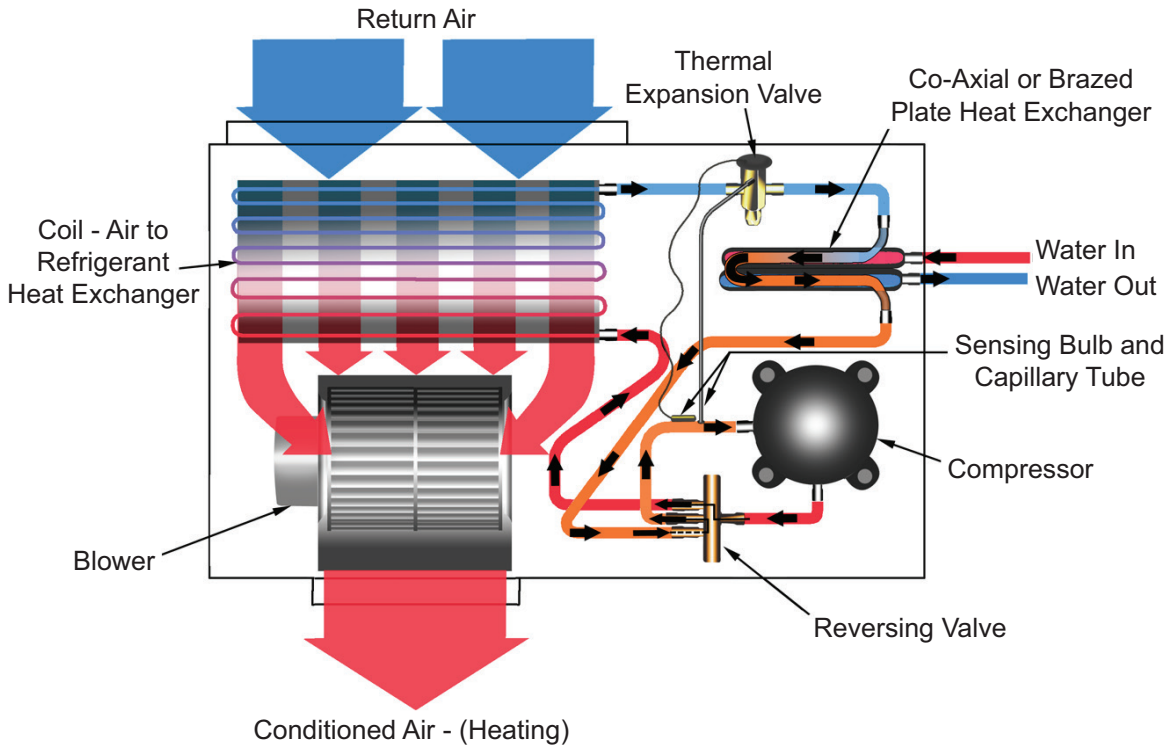

Figure 62: Heating Mode



Appendix

Warranty Registration Form

Warranty - Check, Test and Start	Form: 5F-4239
Water Source Heat Pump Equipment Check, Test and Start Form	Group: ATS
	Date: March 2024
	Supersedes: WS-CTS-00.01

This form must be completely filled out and the record retained by the sales representative or the owner in order to comply with the terms of the Daikin Applied warranty.

Installation Data

Job Name _____ Check, Test & Start Date _____

City or Town _____ State _____ Zip _____

Who is Performing CTS _____

General Contractor _____

Equipment Type (Check all that apply)

Closed Loop Open Loop

Geothermal Other (specify) _____

Essential Items Check of System – Note: "No" answers below require notice to installer by memorandum (attached copy.)

Essential Items Check

A. Voltage Check _____ Volts Loop Temp. _____ °F Heating System Water P.H. Levels _____
 Set For _____ °F Cooling

B. Yes	No	Condition	Comments
<input type="checkbox"/>	<input type="checkbox"/>	Loop Water Flushed Clean _____	
<input type="checkbox"/>	<input type="checkbox"/>	Closed Type Cooling Tower _____	
<input type="checkbox"/>	<input type="checkbox"/>	Water Flow Rate to Heat Pump Balanced _____	
<input type="checkbox"/>	<input type="checkbox"/>	Standby Pump Installed _____	
<input type="checkbox"/>	<input type="checkbox"/>	System Controls Functioning _____	
<input type="checkbox"/>	<input type="checkbox"/>	Outdoor Portion of Water System Freeze Protected _____	
<input type="checkbox"/>	<input type="checkbox"/>	Loop System Free of Air _____	
<input type="checkbox"/>	<input type="checkbox"/>	Filters Clean _____	
<input type="checkbox"/>	<input type="checkbox"/>	Condensate Traps Installed _____	

Note: "No" answers below require notice to installer by memorandum (attached copy.)

Outdoor Air to Heat Pumps: _____

Other Conditions Found: _____

Please include any suggestions or comments for Daikin Applied: _____

Above System is in Proper Working Order

Note: This form must be retained. If a warranty claim is submitted, this form will need to be sent to the warranty administrator before any service money can be released.

Date

Signature for Sales Representative

Signature for Customer

For Internal Use

Release:

SM _____

CTS _____

T _____

Service Manager Approval

Date

Warranty Registration Form

Unit Check / Equipment Data

Installation Data

Job Name _____ Check Test Date: _____
 City _____ State _____ Zip _____
 Daikin Model # _____
 Daikin Serial # _____ Job site Unit ID # (HP #) _____
 General Contractor: _____ Mechanical Contractor: _____
 Technician Performing Start-Up: Name _____ Employer: _____
Complete equipment data from measurements taken at the locatons indicated on the drawing below.

Equipment Data

Flow Rate **EWP - LWP = ΔP**
 ① EWP - PSI In _____ minus ② LWP - PSI Out _____ equals ΔP _____
 The first step in finding GPM is to subtract leaving water pressure from entering water pressure. The difference between the two is referred to as ΔP. ΔP can be converted to GPM by looking in the equipment specification catalog.
Caution ΔP ≠ GPM
Note: A conversion table must be used to find GPM from (Delta) ΔP measurements.

Loop Fluid Temperature Rise / Drop through Coaxial Heat Exchanger **EWT - LWT = ΔT**
 ③ EWT - °F Out _____ minus ④ LWT - °F Out _____ equals Fluid ΔT _____
 ΔT is the rise or drop in the fluid temperature as it passes through the Coaxial.

Air Temperature Rise / Drop through the air coil **ΔT x CFM x 1.08 = BTUH Sensible**
 ⑤ EAT - °F In _____ minus ⑥ LAT - °F Out _____ equals Air ΔT _____

Note: Perform Check, Test and Start-Up in the Cooling Mode Only.

EWT - Entering Water Temperature EWP - Entering Water Pressure EAT - Entering Air Temperature Δ- Delta (Differential)
 LWT - Leaving Water Temperature LWP - Leaving Water Pressure LAT - Leaving Air Temperature CFM - Cubic Feet/Minute
 BTUH - British Thermal Units/Hour

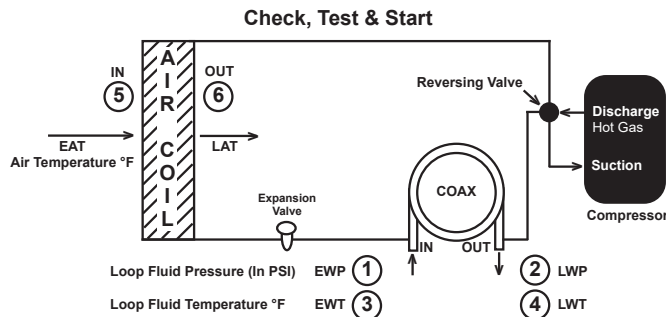

Warranty Registration Form

Commercial Check, Test and Start Worksheet

(Complete all equipment measurements indicated for each unit per installation on page 2)

	Model	Serial #	H.P. #	EWT ③	LWT ④	EWP ①	LWP ②	EAT ⑤	LAT ⑥	Volts	Amps Cooling	Check Air Filter and Coil	Comments (more comments on back)
1.													
2.													
3.													
4.													
5.													
6.													
7.													
8.													
9.													
10.													
11.													
12.													
13.													
14.													
15.													
16.													
17.													
18.													
19.													
20.													
21.													
22.													
23.													
24.													
25.													
26.													
27.													
28.													
29.													
30.													
31.													
32.													
33.													
34.													
35.													
36.													
37.													
38.													
39.													
40.													
41.													
42.													

Limited Product Warranty



**DAIKIN APPLIED AMERICAS INC.
LIMITED PRODUCT WARRANTY
(United States and Canada)**

WARRANTY

Daikin Applied Americas Inc. dba Daikin Applied ("Company") warrants to contractor, purchaser and any owner of the product (collectively "Owner") that, subject to the exclusions set forth below Company, at its option, will repair or replace defective parts in the event any product manufactured by Company, including products sold under the brand name Daikin and used in the United States or Canada, proves defective in material or workmanship within twelve (12) months from initial startup or eighteen (18) months from the date shipped by Company, whichever occurs first. Authorized replacement parts are warranted for the remainder of the original warranty. All shipments of such parts will be made FOB factory, freight prepaid and allowed. Company reserves the right to select carrier and method of shipment. In addition, Company provides labor to repair or replace warranty parts during Company normal working hours on products with rotary screw compressors or centrifugal compressors. Warranty labor is not provided for any other products.

Company must receive the Registration and Startup Forms for products containing motor compressors and/or furnaces within ten (10) days of original product startup, or the ship date and the startup date will be deemed the same for determining the commencement of the warranty period and this warranty shall expire twelve (12) months from that date. For additional consideration, Company will provide an extended warranty(ies) on certain products or components thereof. The terms of the extended warranty(ies) are shown on a separate extended warranty statement.

No person (including any agent, sales representative, dealer or distributor) has the authority to expand the Company's obligation beyond the terms of this express warranty or to state that the performance of the product is other than that published by Company.

EXCLUSIONS

1. If free warranty labor is available as set forth above, such free labor does not include diagnostic visits, inspections, travel time and related expenses, or unusual access time or costs required by product location.
2. Refrigerants, fluids, oils and expendable items such as filters are not covered by this warranty.
3. This warranty shall not apply to products or parts : (a) that have been opened, disassembled, repaired, or altered, in each case by anyone other than Company or its authorized service representative; (b) that have been subjected to misuse, abuse, negligence, accidents, damage, or abnormal use or service; (c) that have not been properly maintained; (d) that have been operated or installed, or have had startup performed, in each case in a manner contrary to Company's printed instructions; (e) that have been exposed, directly or indirectly, to a corrosive atmosphere or material such as, but not limited to, chlorine, fluorine, fertilizers, waste water, urine, rust, salt, sulfur, ozone, or other chemicals, contaminants, minerals, or corrosive agents; (f) that were manufactured or furnished by others and/or are not an integral part of a product manufactured by Company; or (g) for which Company has not been paid in full.
4. This warranty shall not apply to products with rotary screw compressors or centrifugal compressors if such products have not been started, or if such startup has not been performed, by a Daikin Applied or Company authorized service representative.

SOLE REMEDY AND LIMITATION OF LIABILITY

THIS WARRANTY CONSTITUTES THE SOLE WARRANTY MADE BY COMPANY. COMPANY'S LIABILITY TO OWNER AND OWNER'S SOLE REMEDY UNDER THIS WARRANTY SHALL NOT EXCEED THE LESSER OF: (i) THE COST OF REPAIRING OR REPLACING DEFECTIVE PRODUCTS; AND (ii) THE ORIGINAL PURCHASE PRICE ACTUALLY PAID FOR THE PRODUCTS. COMPANY MAKES NO REPRESENTATION OR WARRANTY, EXPRESS OR IMPLIED, REGARDING PREVENTION OF MOLD/MOULD, FUNGUS, BACTERIA, MICROBIAL GROWTH, OR ANY OTHER CONTAMINATES. THIS WARRANTY IS GIVEN IN LIEU OF ALL OTHER WARRANTIES, INCLUDING, WITHOUT LIMITATION, THE IMPLIED WARRANTIES OF MERCHANTABILITY, FITNESS FOR A PARTICULAR PURPOSE, AND NON-INFRINGEMENT, WHICH ARE HEREBY DISCLAIMED. IN NO EVENT AND UNDER NO CIRCUMSTANCE SHALL COMPANY BE LIABLE TO OWNER OR ANY THIRD PARTY FOR INCIDENTAL, INDIRECT, SPECIAL, CONTINGENT, CONSEQUENTIAL, DELAY OR LIQUIDATED DAMAGES FOR ANY REASON, ARISING FROM ANY CAUSE WHATSOEVER, WHETHER THE THEORY FOR RECOVERY IS BASED IN LAW OR IN EQUITY, OR IS UNDER A THEORY OF BREACH CONTRACT OR WARRANTY, NEGLIGENCE, STRICT LIABILITY, OR OTHERWISE. THE TERM "CONSEQUENTIAL DAMAGE" INCLUDES, WITHOUT LIMITATION, THOSE DAMAGES ARISING FROM BUSINESS INTERRUPTION OR ECONOMIC LOSS, SUCH AS LOSS OF ANTICIPATED PROFITS, REVENUE, PRODUCTION, USE, REPUTATION, DATA OR CROPS.

ASSISTANCE

To obtain assistance or information regarding this warranty, please contact your local sales representative or a Daikin Applied office.

Form No. 933-430285Y-01-A (11/2023)
Part No. 043028500 Rev.0F

COMPLETE HVAC SYSTEM SOLUTIONS

SELF-CONTAINED | ROOFTOPS | COILS | CONDENSING UNITS
AIR HANDLERS | WATER-COOLED CHILLERS | AIR-COOLED CHILLERS
MODULAR CENTRAL PLANTS | SITELINE BUILDING CONTROLS
UNIT HEATERS | FAN COILS | AIR PURIFIERS | WATER SOURCE HEAT PUMPS
VARIABLE AIR VOLUME UNITS | UNIT VENTILATORS



13600 INDUSTRIAL PARK BLVD. | MINNEAPOLIS, MN 55441
1-800-432-1342 | 763-553-5330

LEARN MORE AT
DAIKINAPPLIED.COM

PART NUMBER: IM1379

© 2024 DAIKIN APPLIED | (800) 432.1342 | WWW.DAIKINAPPLIED.COM