



# Installation and Maintenance Manual

# IM 817-9

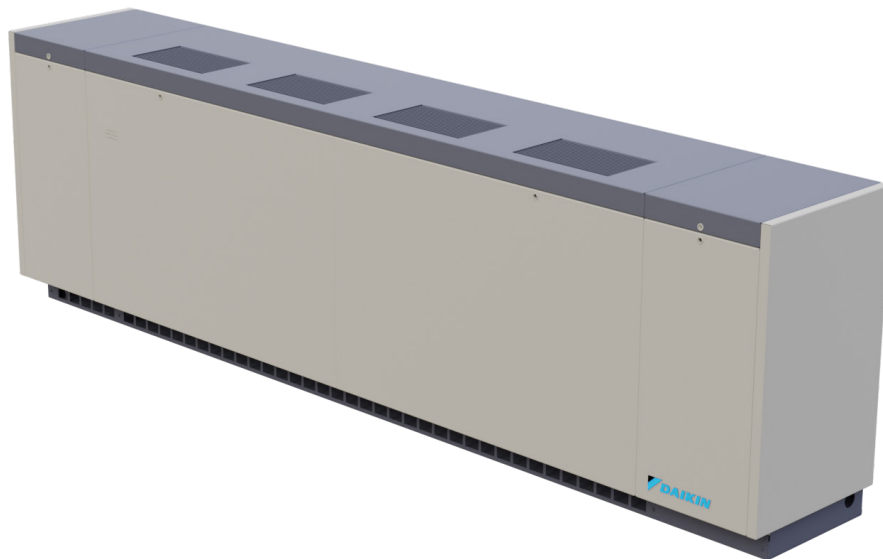
Group: **ATS**

Document PN: **IM817-9**

Date: **July 2024**

## Classroom Unit Ventilators Floor Models AVS, AVV, AVB and AVR

Digital Ready, MicroTech® Control (“J” Vintage)  
Field Controls by Others



<b>General Data</b> . . . . .	<b>3</b>	<b>Unit Ventilator Split Systems Guidelines</b> . . . . .	<b>36</b>
Model Nomenclature . . . . .	3	Checking System Charge . . . . .	38
Storage . . . . .	4	Determining Subcooling . . . . .	38
Lifting Unit . . . . .	4	Determining System Superheat . . . . .	39
<b>Pre-Installation Information</b> . . . . .	<b>5</b>	Superheat Adjustment . . . . .	40
Safety . . . . .	5	<b>Making Control Connections</b> . . . . .	<b>40</b>
Properly Identify Unit Ventilator(s) . . . . .	6	MicroTech Unit Mounted DDC Control Components – Models AVS, AVV, and AVR . . . . .	40
Uncrate and Inspect the Unit Ventilator(s) . . . . .	6	Typical MicroTech Wiring – 115Volt / 60Hz / 1 Phase . . . . .	44
Wall Openings, Louvers, and VentiMatic™ Shutter . . . . .	6	<b>MicroTech Unit Electrical Connections</b> . . . . .	<b>46</b>
VentiMatic™ Shutter Assembly . . . . .	6	MicroTech Wall Mounted Sensor . . . . .	47
<b>Installing Louvers</b> . . . . .	<b>7</b>	Typical Connections For Temperature Sensor Applications . . . . .	48
Louver Details . . . . .	7	<b>Making Control Connections</b> . . . . .	<b>51</b>
Louver Installation With Typical Unit Configurations . . . . .	8	Digital Ready™ – Face & Bypass Control Components Model AVS . . . . .	51
Typical Installation Methods . . . . .	10	<b>Typical Wiring Diagram</b> . . . . .	<b>53</b>
<b>Installing the VentiMatic Shutter Assembly</b> . . . . .	<b>11</b>	Digital Ready Face and Bypass Control . . . . .	53
<b>Before Setting the Unit in Place</b> . . . . .	<b>12</b>	Digital Ready Unit Mounted Temperature Sensor Specifications . . . . .	54
Removing Unit from the Skid . . . . .	12	Digital Ready – Damper Actuator Specifications . . . . .	55
Mounting Holes, Piping and Electrical Knockout Locations & Dimensions . . . . .	13	Digital Ready Unit Electrical Connections . . . . .	56
Reversing Drain Pan Slope . . . . .	13	Controls by Others Components . . . . .	57
Typical Floor Unit Installation . . . . .	15	Typical Controls by Others Wiring Diagram – Units with Optional EC Motor with Variable Airflow . . . . .	59
<b>Unit Ventilator Installation</b> . . . . .	<b>16</b>	Controls by Others – Field Installed . . . . .	60
Make Piping Connections . . . . .	16	Controls by Others – Electrical Connections . . . . .	61
Water Coil Connections . . . . .	17	Electric Heat Wiring Diagram – Typical . . . . .	63
<b>Coil Headers, Locations</b> . . . . .	<b>18</b>	Electric Heating - PSC Motor . . . . .	64
Heating Only Units . . . . .	18	Electric Heating - EC Motor . . . . .	65
Cooling Only Units . . . . .	19	Draftstop™ System/Window Down-draft Installation . . . . .	66
Heat/Cool Units . . . . .	20	Finned Radiation System . . . . .	69
Reheat Units . . . . .	22	Installing Unit Ventilator End Panels: . . . . .	70
<b>Typical Valve Packages</b> . . . . .	<b>23</b>	<b>Prepare Unit Ventilator(s) for Start-up</b> . . . . .	<b>70</b>
2-Way and 3-Way Hot Water and Chilled Water Modulating Valve Selection . . . . .	28	Battery Backup . . . . .	70
<b>Typical Piping Arrangements</b> . . . . .	<b>29</b>	Oiling the Fan Shaft End Bearing: . . . . .	71
Heating – Hot Water End of Cycle Valve Piping . . . . .	29	Unit Ventilator Start-up . . . . .	71
Chilled Water EOC Valve Piping . . . . .	30	Filter(s) . . . . .	71
Typical Water Coil Piping - EOC Valve Piping . . . . .	30	<b>Complete Check, Test and Start Procedure</b> . . . . .	<b>72</b>
Steam – Typical Modulating Valve Piping . . . . .	31	Installer/Owner’s Responsibility . . . . .	72
Typical Steam Coil Piping . . . . .	32		
Heating – Modulating Valve Piping . . . . .	33		
Cooling – Chilled Water Modulating Valve Piping . . . . .	34		
Condensate Piping: . . . . .	35		

©2024 Daikin Applied, Minneapolis, MN. All rights reserved throughout the world. This document contains the most current product information as of this printing. Daikin Applied Americas Inc. has the right to change the information, design, and construction of the product represented within the document without prior notice. For the most up-to-date product information, please go to [www.DaikinApplied.com](http://www.DaikinApplied.com).

™ MicroTech and Daikin Applied are trademarks or registered trademarks of Daikin Applied Americas Inc. The following are trademarks or registered trademarks of their respective companies: BACnet from American Society of Heating, Refrigerating and Air-Conditioning Engineers, Inc.; Echelon, LonWorks, LonMark, and LonTalk from Echelon Corporation; Modbus from Schneider Electric; and Windows from Microsoft Corporation.

# Model Nomenclature

**U AVV 9 S10 A S 68 A B1 AL 22 G I B 1**  
 1 2 3 4 5 6 7 8 9 10 11 12 13 14 15

Category	Code Item	Code Option	Code Designation & Description												
Product Category	1	1	U	Unit Ventilators											
Model Type	2	2-4	AVS	Floor, Face & Bypass				AVV	Floor, Valve Control						
			AVB	Floor, Face & Bypass, Reheat				AVR	Floor, Valve Control, Reheat						
Design Series	3	5	9	Design J											
Motor Type	4	6	S	PSC Motor, 3-Speed				V	EC Motor, Variable Airflow						
			H	EC Motor, 3-Speed											
Nominal Capacity	4	7-8	07	750 CFM				13	1250 CFM						
			10	1000 CFM				15	1500 CFM						
Voltage	5	9	A	115/60/1				D	208/60/3						
			C	208/60/1				H	230/60/3						
			G	230/60/1				K	460/60/3						
			J	265-277/60/1											
Coil Options	6	10	U [1]	2 Row CW/HW 2 pipe				V [5]	2 Row CW						
			D [2]	3 Row CW/HW 2 pipe				S [6]	3 Row CW						
			E [3]	4 Row CW/HW 2 pipe				W [7]	4 Row CW						
			F [4]	5 Row CW/HW 2 pipe				Y [8]	5 Row CW						
			G [9]	DX				Z	None						
			M [0]	DX for HP Operation											
Heating Options	7	11-12	12	3 Element Low Cap. Electric Heat				68	Steam Low Cap.						
			13	6 Element Low Cap. Electric Heat				69	Steam High Cap.						
			65	1 Row HW				78	Opposite End Steam Low Cap.						
			66	2 Row HW				79	Opposite End Steam High Cap.						
			67	3 Row HW				00	None						
Hand Orientation	8	13	A	Same Hand LH				E	LH Heating/RH Cooling						
			B	Same Hand RH				F	RH Heating/LH Cooling						
			D	RH Electric Heat Only				R	Single Coil Left Hand						
			G	RH Electric Heat / LH Cool				S	Single Coil Right Hand						
Controls	9	14-15	##	MicroTech® Controls (see control code table below)											
			<b>Control Features</b>					<b>Feature Selections</b>							
			Open Protocol	BACnet / Stand-Alone				•		•		•		•	
				LONMARK					•		•		•	•	
			DCV	CO <sub>2</sub> Sensor						•	•		•	•	
			Factory-Installed Keypad	LUI								•	•	•	
								<b>Control Code</b>							
			Economizer Control	Basic				B1	B5	B9	BD	BH	BL	BP	BT
				Expanded				E1	E5	E9	ED	EH	EL	EP	ET
				Leading-Edge				L1	L5	L9	LD	LH	LL	LP	LT
23	Field Mounted Controls (By Others)														
17	Digital Ready														
Discharge	10	16-17	AL	16-5/8" Top Bar Grille											
			AK	21-7/8" Top Bar Grille Partial Adapter Back, Open Tunnel											
			AN	21-7/8" Top Bar Grille Full Adapter Back, Closed Tunnel											
			AP	21-7/8" Top Bar Grille Full Adapter Back, Cold Pipe Tunnel, Top Duct In											
			AM	21-7/8" Top Bar Grille 2" Step, Full Adapter Back, Closed Tunnel											
			AB	21-7/8" Top Bar Grille Full Adapter Back, Closed Pipe Tunnel w/ Solid Back											

**Model Nomenclature (continued)**

**U AVV 9 S10 A S 68 A B1 AL 22 G I B 1**  
**1 2 3 4 5 6 7 8 9 10 11 12 13 14 15**

Category	Code Item	Code Option	Code Designation & Description	
Return Air/Outside Air	11	18-19	22	Return Air Bottom Front/ Outdoor Air Rear
			24	Recirculation Only/ No OA or RA Dampers
			30	Return Air Bottom with Draft Stop/ OA Rear
Power Connection	12	20	G	Box With Switch
			J	Box w/switch, w/USB
			K	Box w/switch, w/SD
			M	Box w/switch, w/USB, w/SD
SKU Type	14	22	B	Standard Delivery
Product Style	15	23	1	1st Style Change

**Figure 1: Data Plate Location**



**⚠ WARNING**

Make sure lifting equipment can handle the weight of the unit safely. Personal injury may result if improper lifting and moving methods are used. See [Table 3 on page 6](#) for approximate shipping weights.

**⚠ CAUTION**

Use 72" length forklift tines, short tines will damage the unit bottom. Improper handling can damage internal components. Do not stand the unit on end or stack (See [Figure 2](#) and [Figure 3](#).)

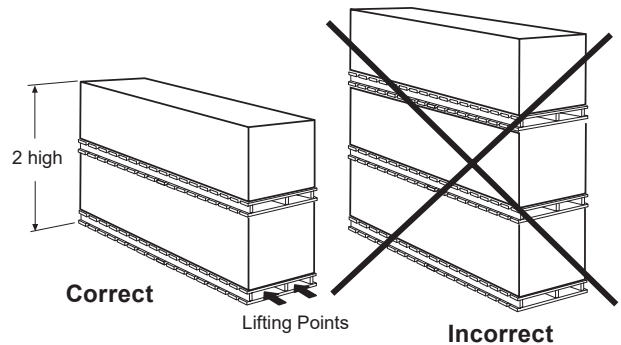
**NOTICE**

All units should be carefully inspected for damage when received. Report all loss or shipping damage using a claim form supplied by Daikin Applied.

**VISIBLE LOSS OR DAMAGE:** Any external evidence of loss or damage must be noted on the freight bill or carrier's receipt, and signed by the carrier's agent. Failure to adequately describe such external evidence of loss or damage may result in the carrier's refusal to honor a damage claim.

**CONCEALED LOSS OR DAMAGE:** Concealed loss or damage means loss or damage which does not become apparent until the unit has been unpacked or unwrapped. The contents may be damaged in transit due to rough handling even though the exterior may not show damages. When the damage is discovered, make a written request for inspection by the carrier's agent within **five (5) days** of the delivery date and file a claim with the form provided by Daikin Applied. Refer to the Daikin Applied Freight Policy for further information.

**Figure 2: Stack Units Maximum 2 High as Shown**



**Figure 3: Forklift Lifting Requirements**



**Storage**

If equipment is stored for any length of time before installation, it should remain in its shipping packaging in a clean, dry, climate controlled area.

**Lifting Unit**

A forklift or other lifting device is needed to install this product.



## Pre-Installation Information

- Before beginning installation, please read this publication in its entirety.
- Directions given in this bulletin for right and left sides assume a position facing the indoor side of the unit ventilator.
- Before beginning installation, if provided, remove the protective plastic film covering the unit painted panels.

### **WARNING**

Plastic packaging is a suffocation hazard, dispose of properly. Keep away from children.

## Safety

Follow all safety codes. Wear safety glasses and work gloves. Use a quenching cloth for brazing operations. Have a fire extinguisher available. Follow all warnings and cautions in these instructions and attached to the unit. Consult applicable local building codes and National Electrical Codes (NEC) for special requirements.

Recognize safety information. When you see a safety symbol on the unit or in these instructions, be alert to the potential for personal injury. Understand the meanings of the words DANGER,

WARNING, and CAUTION. DANGER identifies the most serious hazards that will result in death or severe personal injury;

WARNING means the hazards can result in death or severe personal injury; CAUTION identifies unsafe practices that can result in personal injury or product and property damage.

Improper installation, adjustment, service, maintenance, or use can cause explosion, fire, electrical shock, or other conditions which may result in personal injury or property damage. This product must be installed only by personnel with the training, experience, skills, and applicable licensing that makes him/her “a qualified professional HVACR installer.”

### **DANGER**



Disconnect all electrical power before servicing unit. Electrical shock will cause severe injury or death.

### **WARNING**

Hazardous Voltage!  
Use copper conductors only. Unit terminals are not designed to accept other types of conductors. Failure to do so may cause damage to the equipment.

### **CAUTION**

Personal injury hazard. Wear protective gloves to avoid possible cuts and abrasions from exposed edges. Avoid contact with sharp edges.

### **WARNING**

Cleaning agents may cause serious damage to internal components, such as aluminum coils and electronic controls, etc. Do not operate unit ventilator while building maintenance cleaning agents are in use.

**Table 1: Protocol-Specific Communication Installation Literature and Data**

Description	Manual #
MicroTech Unit Ventilator Protocol Information	ED 19110

**Table 2: Accessory-Specific Installation Literature**

Description	Manual #
MicroTech Unit Ventilator Controller Installation	IM 1286
ServiceTools Operation Manual	OM 732

## Properly Identify Unit Ventilator(s)

To be sure the correct unit ventilator(s) is/are installed in the correct location(s), the installer must check the packing list and unit identification/tagging number(s) against the plans. Further, the unit data plate, (see [Figure 1 on page 4](#)) located on the lower right end of the unit ventilator, contains specific information of standard components as listed in [Table 3](#).

**Figure 4: Shipping Envelope Contents - Located in right end compartment of unit.**



## Uncrate and Inspect the Unit Ventilator(s)

Carefully remove the packaging, remaining alert to any signs of shipping damage. Be careful not to discard components that may be included with the packaging. (You may want to retain some or all of the packaging to provide jobsite unit location information and temporary protection for the unit ventilator after installation.) Be sure to dispose of plastic packaging and protective cardboard properly, in accordance with local recycling rules and guidelines.

If unit is damaged, file a claim with the carrier. Notify your local Daikin Applied representative immediately.

## Wall Openings, Louvers, and VentiMatic™ Shutter

Prior to unit installation, be sure that the exterior wall openings and louvers, as applicable, are ready and in accordance with the job plans.

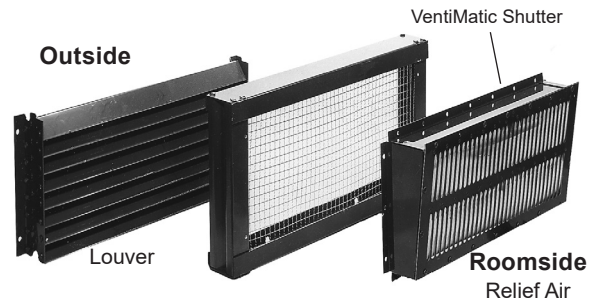
Vertical Floor Models AVS, AVV, AVB, AVR are typically installed in front of a wall opening containing a properly sized louver that is designed to let in outside air while preventing water (such as rain) from getting past the louver and into the unit itself. A weather-tight seal keeps unwanted air and moisture from entering the occupied space. See [Figure 6 on page 7](#) through [Figure 21 on page 11](#), and [Table 4 on page 10](#) for various louver details.

## VentiMatic™ Shutter Assembly

In many installations, a Daikin Applied VentiMatic Shutter Assembly is specified. See [Figure 5](#). This one-way shutter is a continuously variable, gravity actuated, room exhaust vent that operates in direct response to positive static pressure. It opposes any airflow into the room and allows a slight positive pressure.

It is important that the VentiMatic shutter and unit ventilator louvers are mounted on the same wall. This neutralizes the effect of the wind. Forcing excess air into the room through the unit ventilator louver overcomes the same wind pressure that works to keep the VentiMatic shutter closed. This prevents room air exhausting from the room through the VentiMatic shutter.

**Figure 5: VentiMatic Shutter Assembly**



**Note:** Birdscreen and louver are shipped in one (1) piece.

**Table 3: Approximate Shipping Weights, Physical Data**

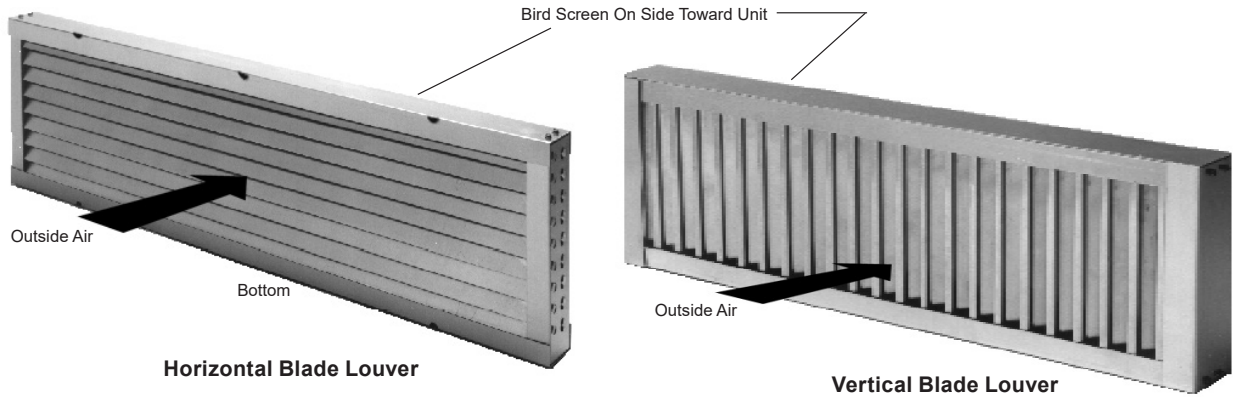
Models AVS, AVV, AVR, AVB	Shipping Weight lbs. (kg)	Approx. Shipping Weight lbs. (kg)	Shipping Size (Carton & Pallet) in. (mm)	Filter Size in. (mm)	Unit Length* in. (mm)	Number of Fans
	16 <sup>5</sup> / <sub>8</sub> " Units	21 <sup>7</sup> / <sub>8</sub> " Units				
07	350 (168)	370 (163)	67L x 23W x 36.39H (1702 x 584 x 924)	10 x 36.5 x 1 (254 x 927 x 25)	62 (1575)	2
10	425 (193)	445 (202)	79L x 23W x 36.39H (2007 x 584 x 924)	10 x 48.5 x 1 (254 x 1232 x 25)	74 (1880)	3
13	495 (225)	525 (238)	91L x 23W x 36.39H (2311 x 584 x 924)	10 x 60.5 x 1 (254 x 1551 x 25)	86 (2174)	4
15	570 (259)	600 (272)	103L x 23W x 36.39H (2616 x 584 x 924)	Two: 10 x 36.5 x 1 (254 x 927 x 25)	98 (2489)	4

\* Measurement is without end panels. All unit ventilators are 30" (762 mm) high.

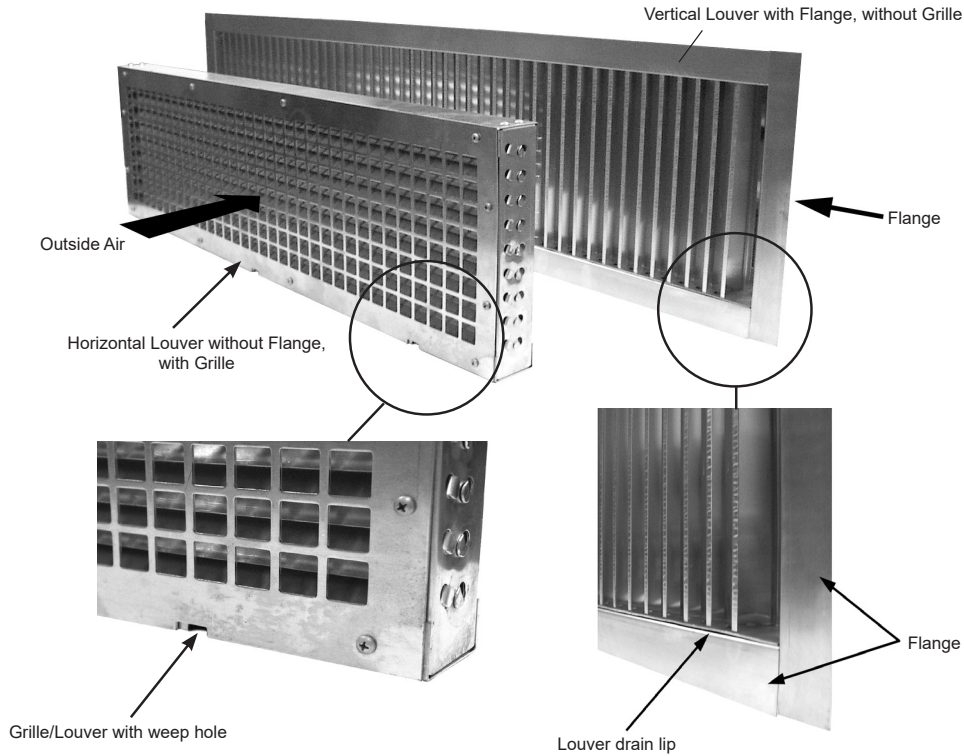
# Installing Louvers

## Louver Details

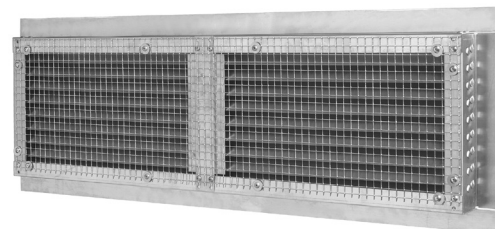
**Figure 6: Horizontal and Vertical Blade Louvers, Without Flange, (see Caution below for louver blade orientation and drainage)**



**Figure 7: Horizontal and Vertical Blade Louvers, Without Flanges With Grille or With Flange Without Grille**



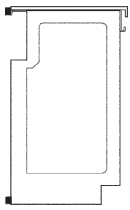
**Figure 8: Rear of Horizontal Blade Louver with Bird Screens and Flange.**



**CAUTION**

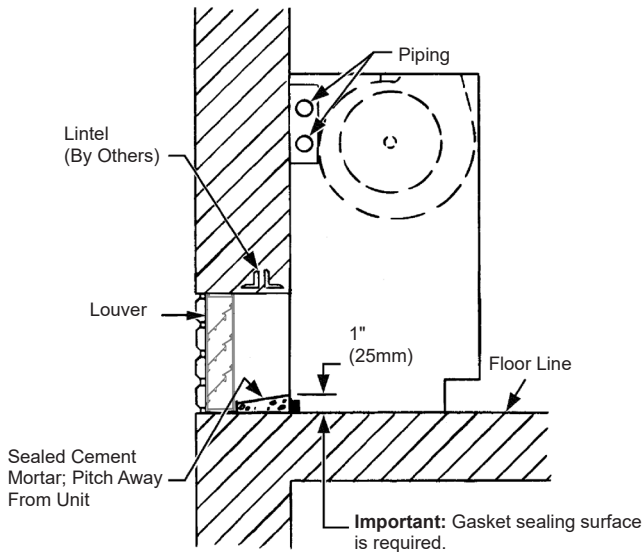
Locate Drain Lip at bottom of vertical louver to allow proper drainage. For horizontal louvers, the louver blades should face down for proper drainage. Bird screen should always be on side toward unit.

# Louver Installation With Typical Unit Configurations

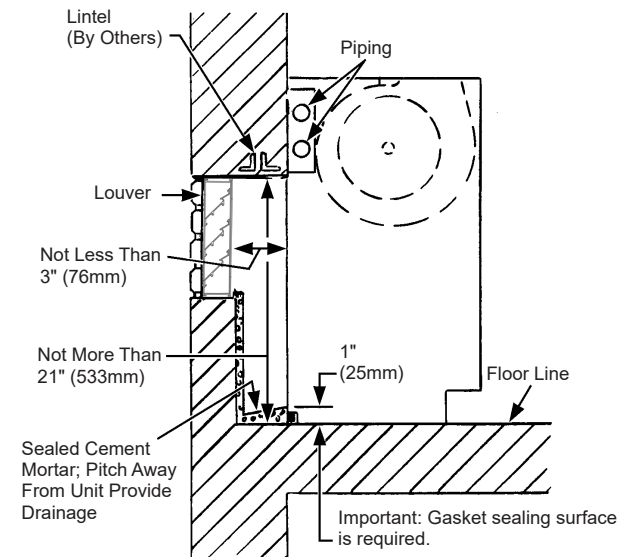


**Unit Configuration Type AL**

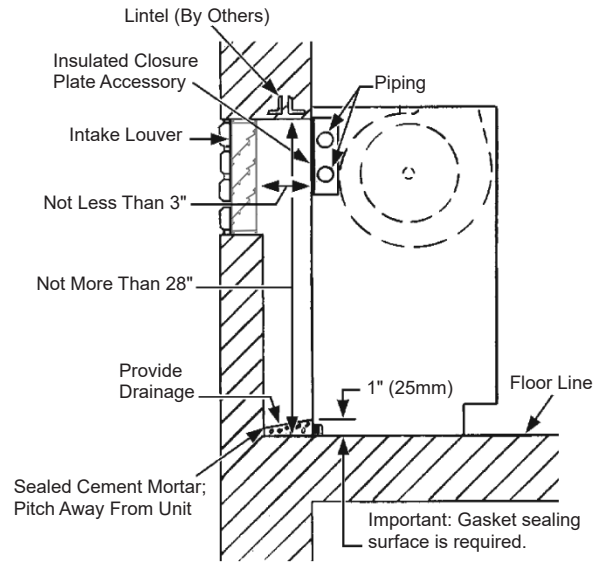
**Figure 9: The 16-5/8" (422mm) Deep Unit with Open Pipe Tunnel and Standard Louver Location**



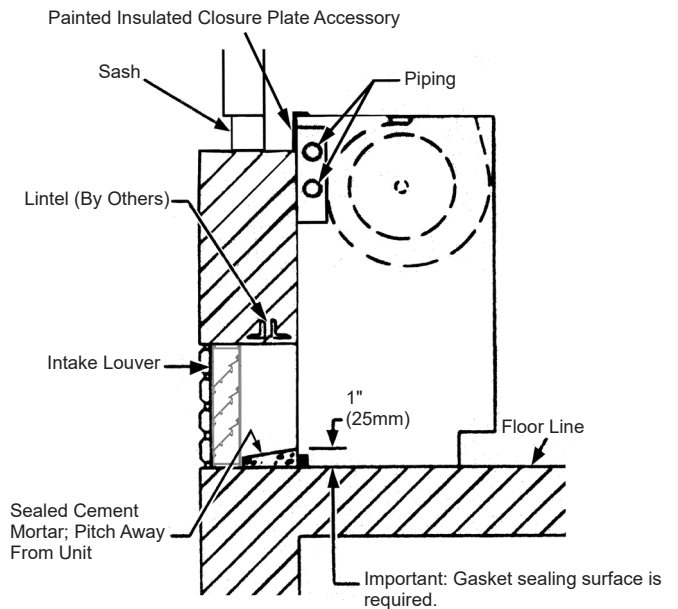
**Figure 10: 16-5/8" (422mm) Deep Unit with Open Pipe Tunnel & High Louver Application with Chased Wall**



**Figure 11: Above Floor Level Outdoor Air Intake Using Arrangement AV or AL With Accessory Closed Pipe Tunnel**

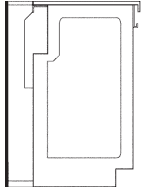


**Figure 12: Floor Level Outdoor Air Intake With Window Below Unit Top Using Arrangement AL And 9" "Finished" (Painted) Accessory (Uninsulated) Closed Pipe Tunnel**



**CAUTION**  
 Accumulated moisture can cause property damage if not properly drained. Installing contractor must provide such drainage.

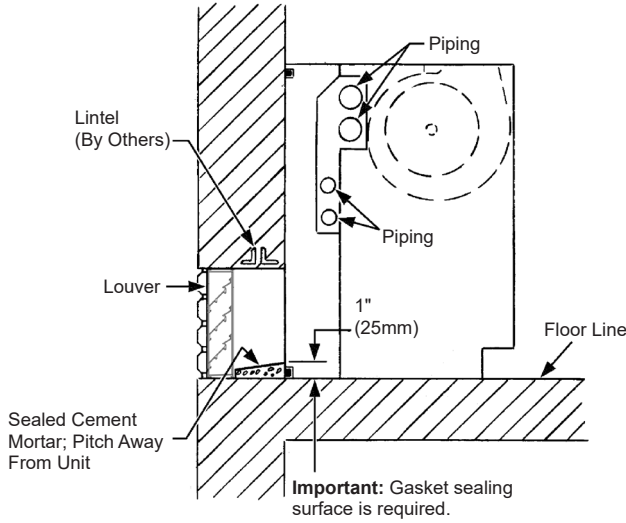
**Louver Installation With Typical Unit Configurations (continued)**



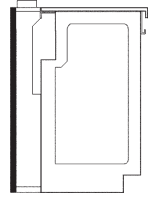
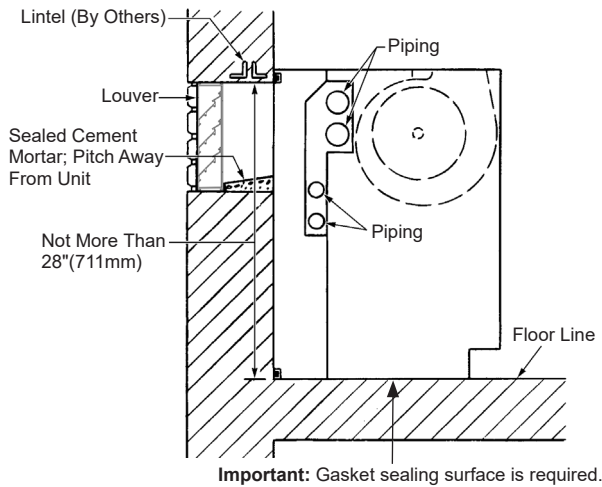
**Unit Configuration Type AN**

**Note:**  
Arrangement AB with full metal back panel, similar to configuration type AN. (Outside air opening to be cut and sealed by others.)

**Figure 13: 21-7/8" (556mm) Deep Full Adapter Back Unit With Standard Louver Application**

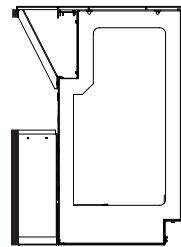
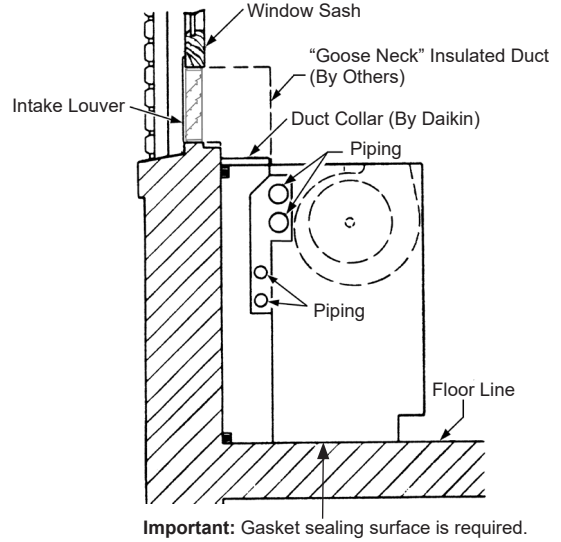


**Figure 14: 21-7/8" (556mm) Deep Full Adapter Back Unit with High Louver Application**



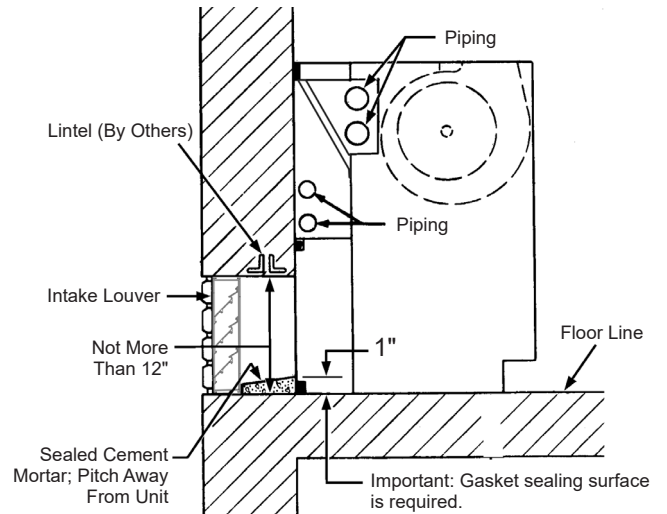
**Unit Configuration Type AP**

**Figure 15: The 21-7/8" (556mm) Deep Full Adapter Back Unit with Closed Pipe Tunnel, Ducted with Top Intake**



**Unit Configuration Type AK**

**Figure 16: 21-7/8" (556mm) Deep Partial Adapter Back Unit with Open Pipe Tunnel**





## Typical Installation Methods

If the fresh air opening has not yet been made, see [Figure 9 on page 8](#) through [Figure 16](#) for the recommended locations and the job-specific plans for the exact location. Follow local codes.

Cut the wall opening so that it is slightly larger than the louver being installed. For dimensions, see [Table 4](#). If the opening is already there, measure to be sure there is a minimum of 3/8" (9mm) clearance around all sides. For masonry installations, a lintel must be installed above all louvers.

In thick wall applications, the portion of the wall between the louver and the unit is the outside air plenum. Line this plenum area with 3/8" (9 mm) mortar or other suitable material. In some applications, the job specifications require a metal sleeve connection between the louver and the unit. If using such a sleeve, properly caulk it to ensure a weather-tight seal. This is critical in preventing freeze-ups, cold drafts, and air infiltration. Be sure the wall is smooth, square, and provides a suitable mating surface.

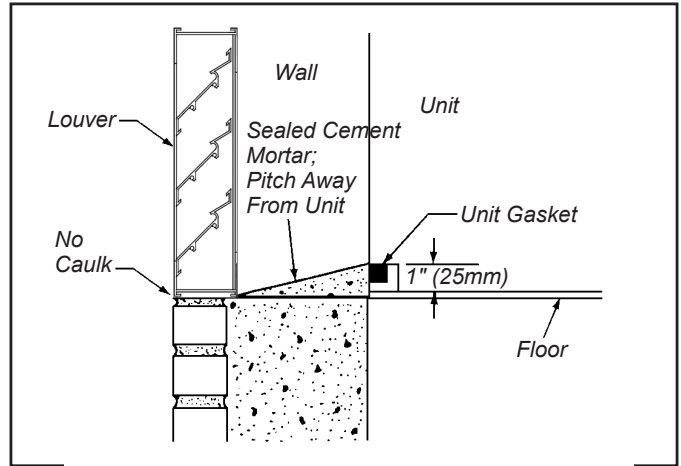
**Table 4: Recommended Wall Openings For Wall Louvers**

B	C	Recommended Wall Openings For Wall Louvers		Maximum Number of VentiMatic Shutters Which Can Be Mounted On Standard Louver		VentiMatic Shutter(s) Air Capacity Maximum	
		Length	Height	24" Shutter	36" Shutter	cfm	L/s
24" (610)	27" (659)	24 <sup>5</sup> / <sub>8</sub> " (613)	10 <sup>7</sup> / <sub>8</sub> " (267)	1	0	500	236
36" (914)	39" (991)	36 <sup>5</sup> / <sub>8</sub> " (918)	10 <sup>7</sup> / <sub>8</sub> " (267)	0	1	750	354
48" (1219)	51" (1295)	48 <sup>5</sup> / <sub>8</sub> " (1222)	10 <sup>7</sup> / <sub>8</sub> " (267)	2	0	1000	472
60" (1524)	63" (1600)	60 <sup>5</sup> / <sub>8</sub> " (1527)	10 <sup>7</sup> / <sub>8</sub> " (267)	1	1	1250	590
72" (1829)	75" (1905)	72 <sup>5</sup> / <sub>8</sub> " (1832)	19 <sup>7</sup> / <sub>8</sub> " (495)	0	2	1500	708

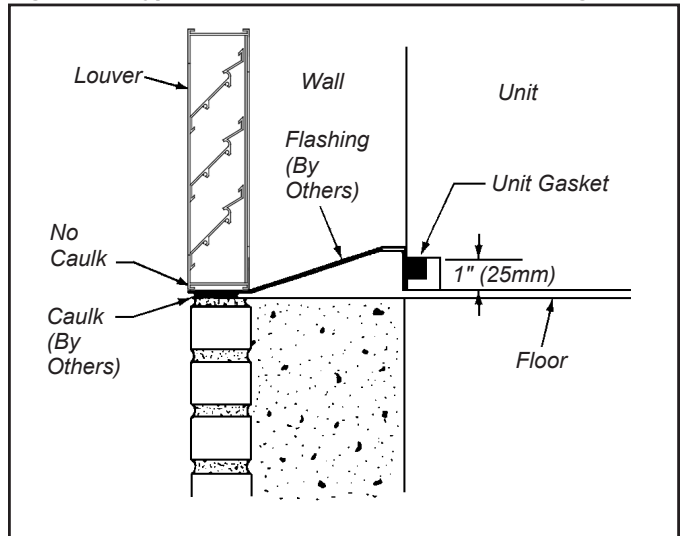
Before setting the louver, construct a sloping, sealed cement mortar base to drain unwanted moisture to the outside, (see [Figure 17](#)). Be sure the mortar base is 1" (25mm) thick at the unit and tapers toward the louver. The mortar at the unit also acts as a backing against which the open cell gasket of the unit itself can seal. This is critical in preventing water leaks and air leaks under the unit. Be sure the sealed cement mortar base is smooth and flush with the interior wall.

If it is not possible to construct a sloping mortar base, then field-supplied flashing is required. See [Figure 18](#). The flashing should terminate flush with the exterior of the building. Place a bead of caulk under the flashing to prevent moisture from wicking back to the unit. Do not caulk the joint between the louver and the flashing. This joint is designed to let unwanted moisture escape.

**Figure 17: Typical Louver Installation with Sloping Sealed Cement Mortar Base**



**Figure 18: Typical Louver Installation with Flashing**



### CAUTION

Personal injury hazard. Wear protective gloves to avoid possible cuts and abrasions from exposed edges. Avoid contact with sharp edges.

See [Figure 6 on page 7](#) through [Figure 21 on page 11](#). Before setting the louver, be sure the drain lip (vertical louver) are at the bottom, horizontal louver blades face down and the bird screen is towards the unit. See [Figure 20](#) and [Figure 21 on page 11](#). Place a heavy bead of caulk along the top and the two vertical sides of the louver, leaving the bottom uncaulked so that if moisture gets into the area between the louver and the unit, it can drain to the outside, unrestricted.

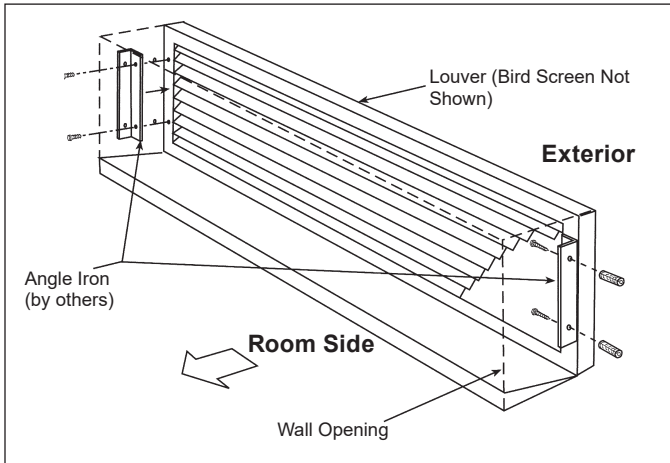
If the louver is supplied with flanges, ([Figure 20](#)) place an additional bead of caulk on the inside of the top and side flanges that come in contact with the building facade. Do not caulk the bottom flange. Place the louver in the opening and push it tight against the supplied building,

fastening it to the exterior of the building using fasteners (by others) appropriate to the installation. Seal the top and sides with a waterproof caulk to make it weather-tight. Do not caulk the bottom of the louver; doing so might trap unwanted moisture behind the flange.

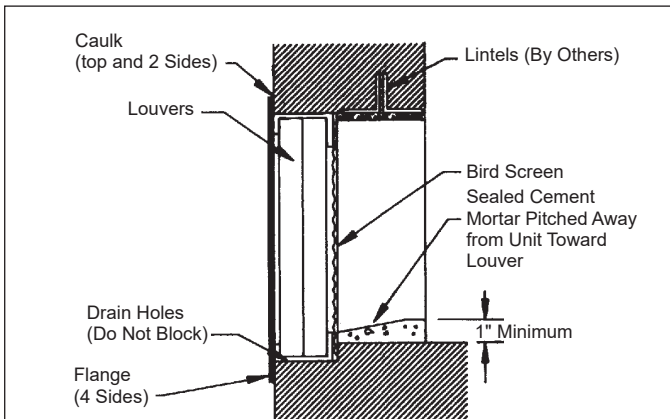
If the louver is supplied with no flanges, (Figure 21) place the louver in the opening so that it is recessed a minimum 1/16" (2mm) beyond the building facade or as directed in the architectural plans. If specified in the plans, secure the louver in the wall using mechanical fasteners (supplied by others) appropriate to the installation. (See Figure 19 for suggested fastening). With the louver solidly in place, run a bead of caulk around the perimeter of the louver to seal it weather-tight. Do not plug the weep holes (horizontal louver) or the drip line (vertical louver). This might restrict the flow of unwanted moisture to the outside.

See Figure 18 on page 10, if flashing was used instead of the sloping mortar base. Caulk the flashing where it meets the inside of the opening between the louver and the unit. This helps prevent moisture from getting under the flashing and into the room.

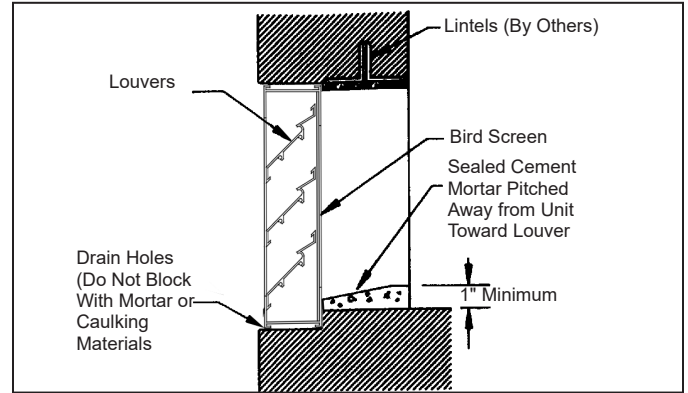
**Figure 19: Suggested method for fastening louver (without flange) inside wall opening.**



**Figure 20: Vertical or Horizontal Blade Wall Intake Louver (Flanged) (Vertical Blade Shown)**



**Figure 21: Vertical or Horizontal Blade Wall Intake Louver (Recessed Without Flange) (Horizontal Blade Shown)**



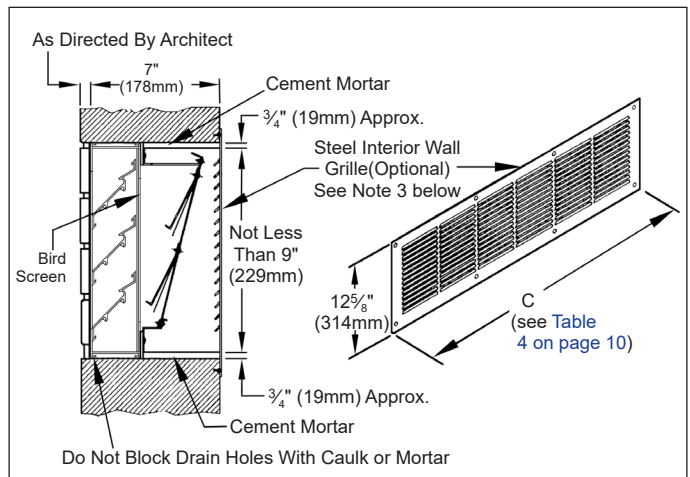
## Installing the VentiMatic Shutter Assembly

The VentiMatic Shutter Assembly is mounted on an installed wall louver. For larger units with 100% ventilation air dampers, two VentiMatic Shutters may be mounted side by side on the same louver, see Figure 24 on page 12.

The size and appearance of the wall louvers with or without optional grilles used with the unit ventilator, and the VentiMatic Shutter, are identical.

When installing VentiMatic Shutter(s) on the wall louver, make sure all moving parts are free to operate unobstructed and placed level and plumb for proper operation. If optional steel interior wall grille is furnished, install as shown in Figure 22.

**Figure 22: Louver, VentiMatic Shutter, Interior Wall Grille Details, Dimensions**

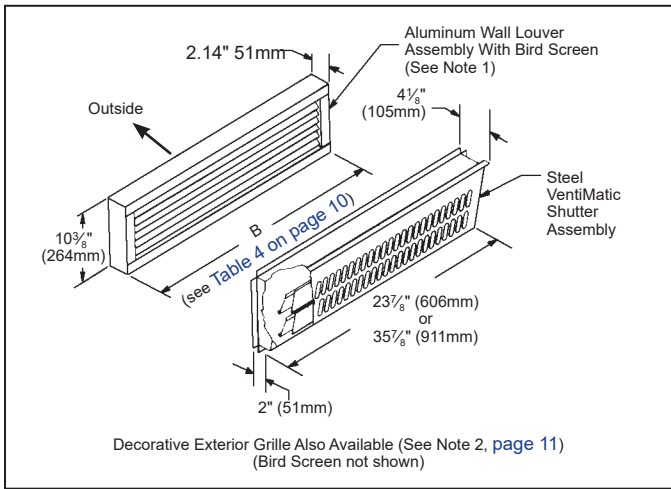


**Notes:**

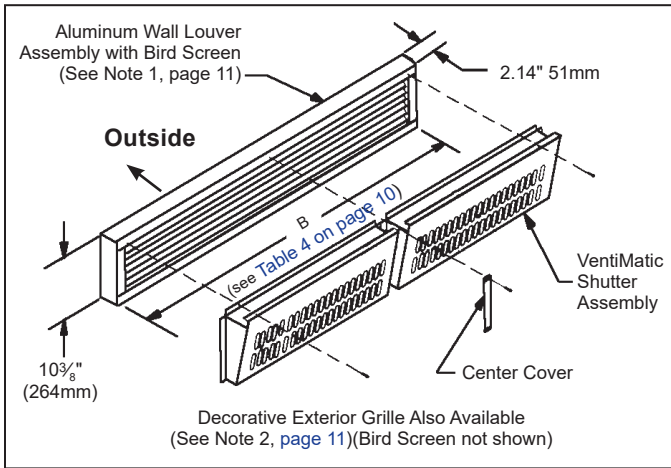
1. Horizontal blade wall louver shown. Vertical blade wall louver also available with VentiMatic shutter.
2. Optional exterior grille matches unit ventilator wall louver in material and design. Mounted on wall louvers.
3. Optional steel interior wall grille should be used to conceal the interior wall opening whenever the VentiMatic shutter is not located behind shelf cabinets or DraftStop enclosure. Hardware to mount the interior wall grille is not included.



**Figure 23: Single VentiMatic Shutter & Wall Louver**



**Figure 24: Two VentiMatic Shutters & Wall Louver**



## Before Setting the Unit in Place

Move the unit ventilator to the correct location. See [Table 3 on page 6](#) for approximate shipping weights.

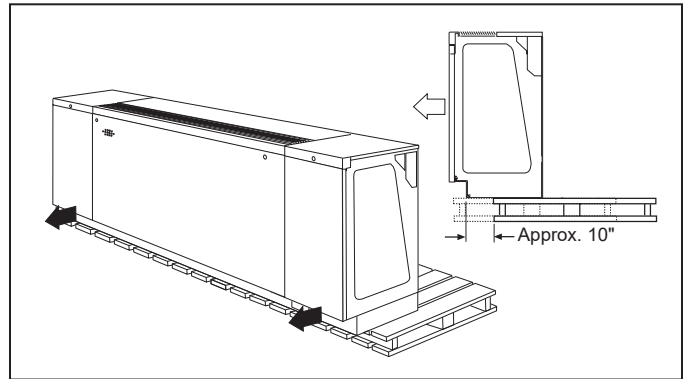
Carefully remove unit ventilator from wood skid. Be sure to properly dispose of the skid in accordance with local recycling rules and guidelines.

## Removing Unit from the Skid

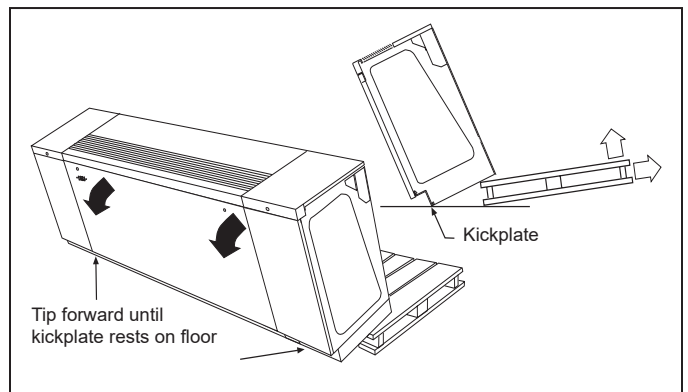
Remove fasteners at each end which hold the unit to the skid and carefully slide the front of the unit off the skid (1). Tip unit forward until the bottom of the slotted front kickplate is resting on the floor (2). Lift rear of unit off of the skid by tipping unit forward while supporting the unit from the front, until it is possible to slide skid out from under the unit. GENTLY LOWER the rear of the unit to the floor (3).

**Figure 25: Removing Unit from Skid**

1. Carefully slide the front of the unit off the front of the skid.



2. While supporting unit from the front, slowly tip unit forward until bottom of kickplate is resting on floor. Lift skid slightly and GENTLY lower the rear of the unit to the floor while pulling skid back (DO NOT LET THE UNIT DROP).

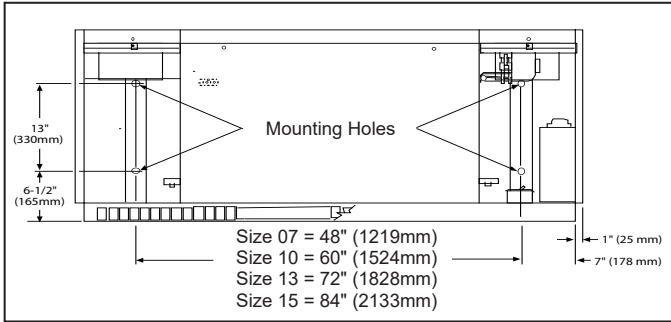


## **⚠ CAUTION**

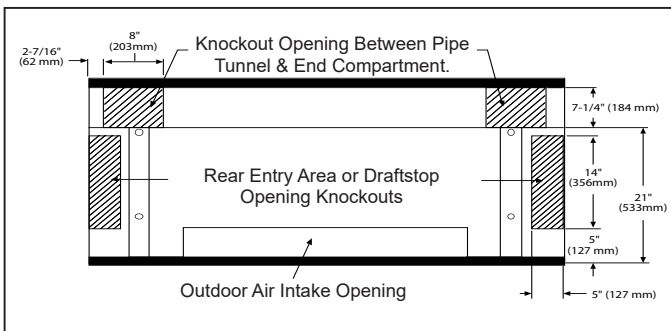
Leakage of outdoor air wastes energy, causes drafts and erratic unit ventilator operation. Check the following details: At the correct unit ventilator location, examine the wall surface. Make sure that it is smooth, plumb, and perpendicular to the floor. The seals on the rear of the unit ventilator will take up the small irregularities found in normal masonry construction. If the wall is irregular or has mullions, install furring strips to provide a flush surface against which the unit ventilator can seal. If there are moldings on the floor/wall line, omit them behind the unit ventilator. Provide a sealing surface at the floor line. Install a seal pad under the unit to prevent air leakage. Install the unit ventilator against a wall made of non-combustible material, and on a floor made of non-combustible material. Floor must be level, unbroken and structurally strong to support the unit.

# Mounting Holes, Piping and Electrical Knockout Locations & Dimensions

**Figure 26: Front View with End Panels - Mounting Holes Locations**



**Figure 27: Rear View without End Panels and Subbase - Piping and Electrical Knockout Locations and Dimensions**



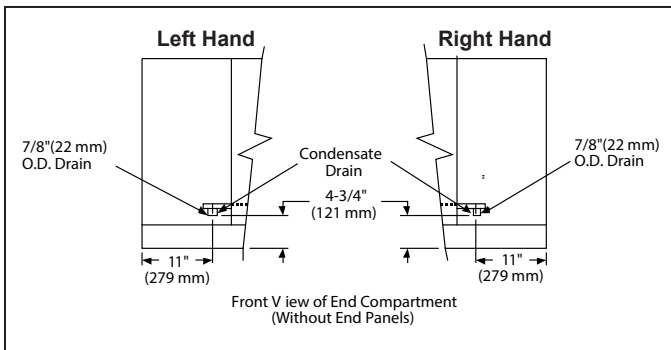
**NOTICE**

End compartment Draftstop knockouts must be removed for proper Draftstop operation. (21-7/8" units only)

**Note:** See Draftstop IM bulletin (IM 473) for suggested installation procedure.

## Reversing Drain Pan Slope

**Figure 28: Condensate Drain Pan Connection Location**



**DANGER**

Disconnect all electrical power before servicing unit to prevent injury or death due to electrical shock.

**CAUTION**

Personal injury hazard. Wear protective gloves to avoid possible cuts and abrasions from exposed edges. Avoid contact with sharp edges.

## Procedure

If the unit has a cooling coil, check the condensate drain pan to be sure it slopes down toward the drain stub-up end. To do so, compare the right and left hand drain pan ends to [Figure 30](#) & [Figure 31](#) on page 14. The end with the shallow lower bracket ([Figure 30](#) on page 14) is the low end of the drain pan. To reverse the slope of the drain pan do the following:

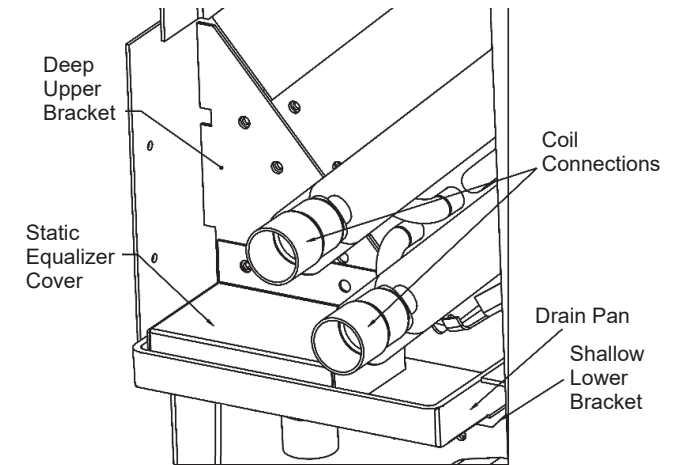
1. Remove the lower bracket and upper plate from each end of the unit, as shown in [Figure 30](#) and [Figure 31](#) on page 14. This is done by removing the screws in each with a 1/4 inch nut driver.
2. Reinstall the brackets on the opposite end of the unit.

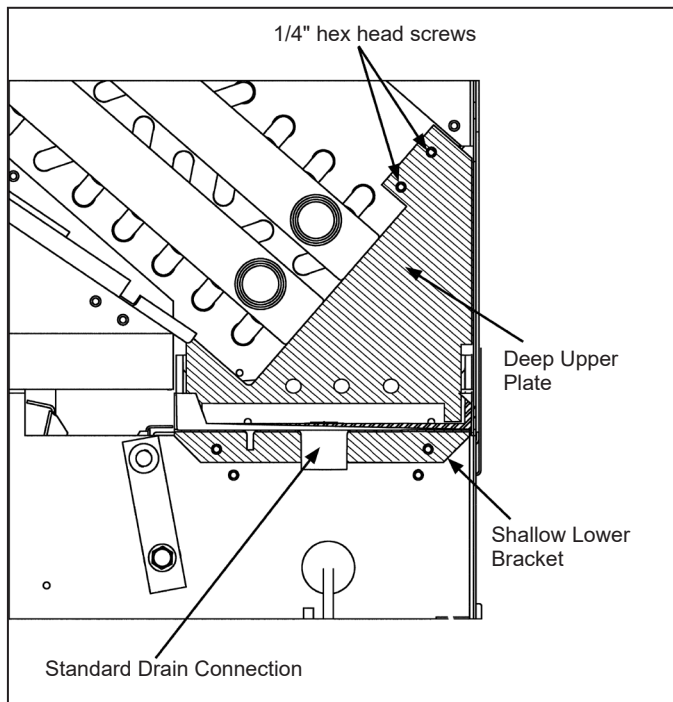
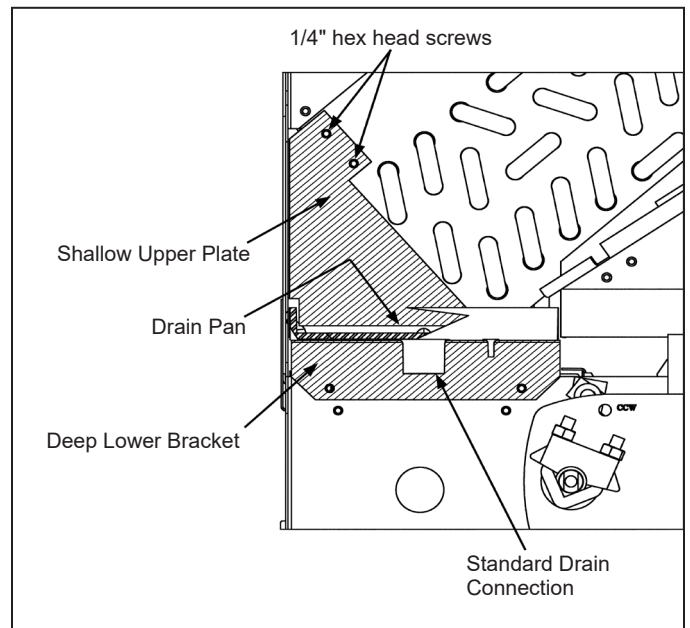
**NOTICE**

The drain pan has two (2) connections on each end; a standard drain connection and an overflow connection.

3. Verify the standard drain connection is open on the low (drain) end only. If the drain connection stub-outs at the high end of the drain pan are open, seal them water tight with silicone sealer or similar.
4. Mount static equalizer cover to low end bracket of drain pan.

**Figure 29: Mount Static Equalizer Cover**



**Figure 30: Low End of Drain Pan (Drain End)****Figure 31: High End of Drain Pan**

### To Clean the Drain Pan

1. Remove the shallow and deep upper plates from the unit.
2. Spray water into the drain pan on the high end to wash debris to the low end (drain end).
3. Remove any debris, making sure that the drain holes are not obstructed.
4. Wipe the drain pan with a cloth.
5. Reinstall the upper plates.

# Typical Floor Unit Installation

Figure 32: Typical Classroom Unit Ventilator Installation And Louver Details (see installation section for typical warnings and cautions)

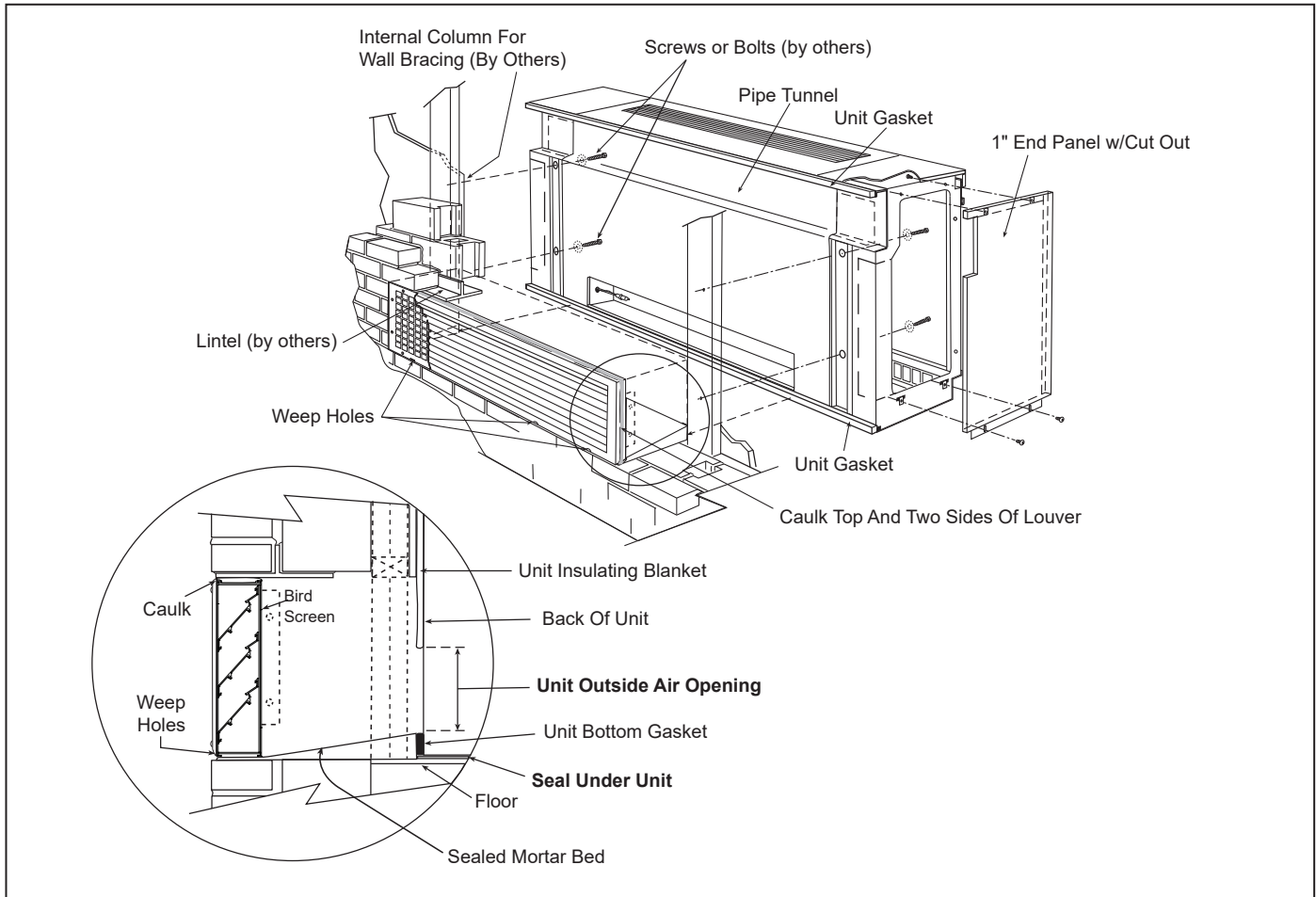
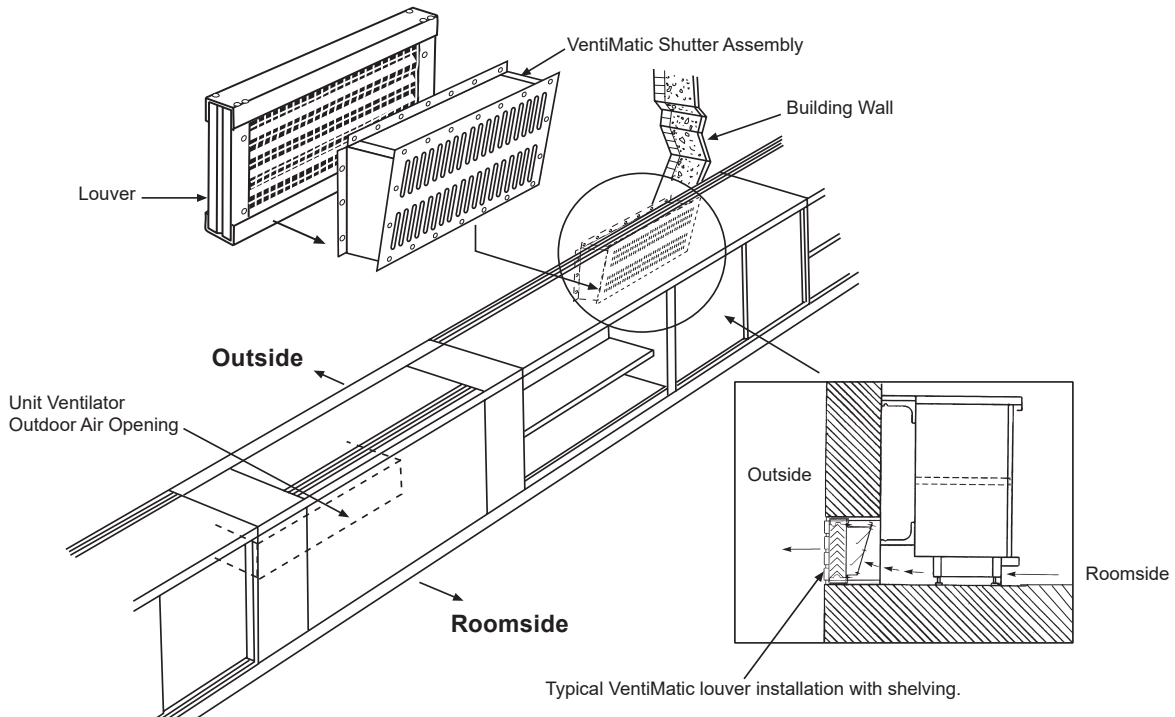


Figure 33: Typical VentiMatic Shutter Assembly Installation (see installation section for typical warnings and cautions)

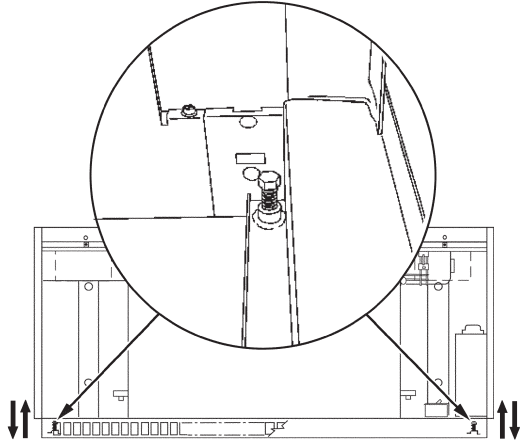


# Unit Ventilator Installation

Before setting the unit ventilator in position, be sure that field-supplied electrical connections are in place, de-energized and in accordance with the plans.

Move the unit ventilator into position against the wall surface. Check to see that the unit ventilator is level from end to end and back to front. Using a 4' level is recommended. Leveling bolts are located at each end of the front kickplate (Figure 34).

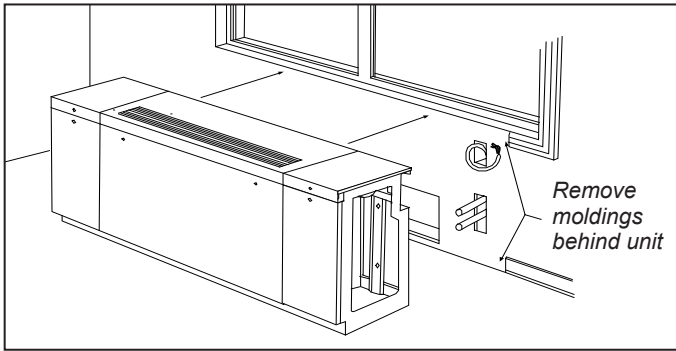
**Figure 34: Leveling Legs Location**



**NOTICE**

Face and Bypass damper set-up is required at start-up. Failure to properly set-up Face and Bypass damper can result in control problems and unit damage not covered by warranty. Refer to Service Bulletin, UV-SB-106507312.

**Figure 35: Setting The Unit Ventilator In Place**



Refer to Figure 32 on page 15 and Figure 26 and Figure 27 on page 13 and attach the unit ventilator to the wall through the four (4) mounting holes provided, using field-supplied fasteners appropriate to the wall construction and the washers provided in the brown envelope with these instructions (Figure 36). Envelope also contains Allen wrench to provide access to unit. Push the unit ventilator tight to the wall structure so that the outdoor air seals are compressed. Secure the wall fasteners to prevent the unit ventilator from moving and tipping over.

**Figure 36: Shipping Envelope Contents.**



## Make Piping Connections

**CAUTION**

Be sure the hot and chilled water supply and return system are thoroughly flushed and cleaned before connecting piping to the unit ventilator. Debris in the lines can damage the unit.

### For All Systems

Be sure to install the control valve(s) on the correct unit ventilator. Indiscriminate mixing of valves in the field can result in valves improperly sized for the desired flow rate, which can result in poor operation and coil freezeups. Install control valve so there is at least 2" (51mm) minimum clearance to remove the actuator from the valve body.

Be certain that the control valve is installed correctly, with its orientation vertical. Valves should be installed at least 5 degrees off center.

**CAUTION**

Be certain that the control valves are installed with the proper port orientation to provide proper flow and fail safe operation. Incorrect installation can result in improper unit operation, and/or the possibility of coil freeze-up.

With future servicing considerations in mind, use standard, field-supplied shutoff valves and union connections; this permits easy removal of the coil or control valve if servicing is required.

**WARNING**

While brazing, have an extinguisher readily available. Wear appropriate eye and hand protection. Ensure all areas with shared ventilation have ample fresh air ventilation.

Proper ventilation is required for brazing. When brazing, be sure to protect unit ventilator components from overheating damage (melting insulation, also damage to valves, wiring, electronics, sensors, etc.).

Before filling, be sure to flush all piping adequately so that all debris is removed. Debris can prevent proper valve operation, resulting in overheating, overcooling, etc.



Ensure proper insulation of supply and return piping. Proper insulation prevents loss of unit ventilator capacity, overheating of end compartment, and / or moisture dripping.

The piping to and from the unit must be protected from outside air and freeze conditions. The piping must be suitably insulated for condensation or heat lose or gain. Penetrations entering the unit end compartments must be fitted/sealed for unit integrity.

## Water Coil Connections

Hook up water piping in accordance with [Figure 37](#) and [Figure 38](#) for hot water and chilled water coil connections.

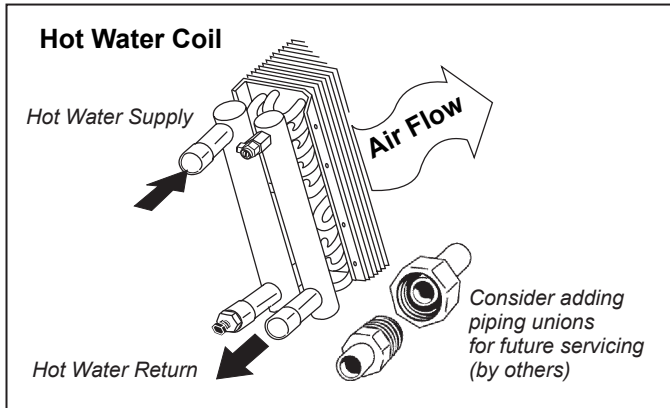
**⚠ CAUTION**

Failure to install water piping to coils properly can result in improper unit operation and coil freeze-ups.

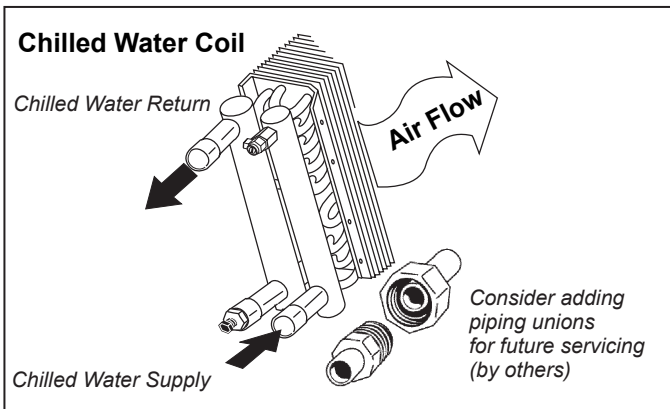
**NOTICE**

Use piping shut off valves and connection unions for future servicing to the coil supply and return stubs, instead of hard piping. This permits easy removal of the coil or control valve if servicing is required.

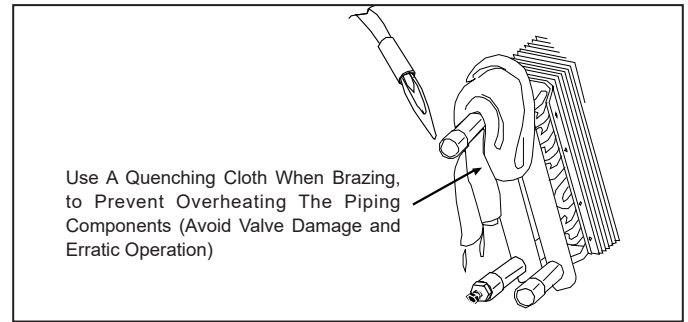
**Figure 37: Hot Water Coil Connections (Right-Hand Shown)**



**Figure 38: Chilled Water Coil Connections (Right-Hand Shown)**



**Figure 39: Protect Components From Overheating Before Brazing**



## 2-pipe Chilled Water/Hot Water Systems

After making the piping connections, securely attach and insulate the water-in temperature sensor (OCT) to the water coil supply line. The sensor should be located on the water supply line in an area where there is continuous water flow. The sensor hangs loose in the same end compartment as the coil connections. This sensor must be attached correctly for proper unit operation.

## After Brazing

Install provided donut shaped insulation seals around pipe fittings, by removing white backing. Press seals up to coil partition to seal gaps in partition insulation.

**⚠ CAUTION**

Donut insulation seals must be installed for proper air flow through the coil.

## For Water Systems

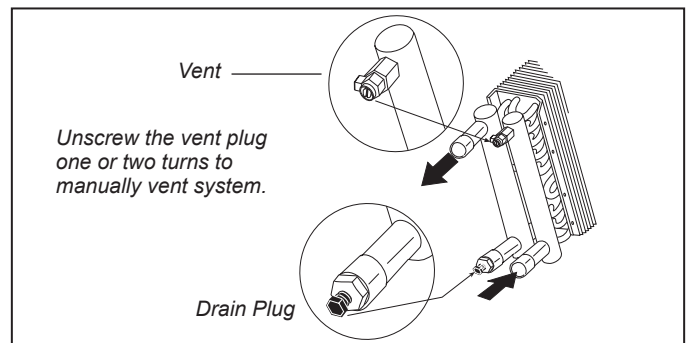
After flushing piping adequately, so all debris is removed, fill the system.

**⚠ WARNING**

Water system under pressure. Keep face and body parts well away from vent. Unscrew the vent plug only one or two complete turns, and vent slowly. Water pressure can result in severe personal injury.

At initial operation, vent manually by unscrewing the vent plug one or two turns, [Figure 40](#). After venting, tighten the vent plug firmly.

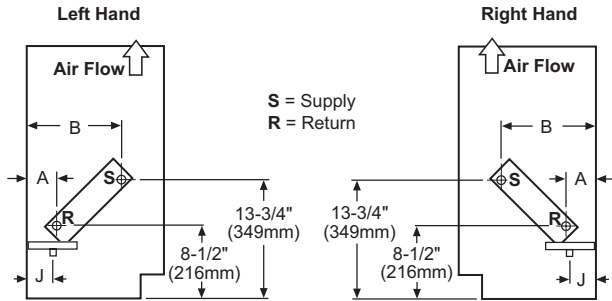
**Figure 40: Vent and Drain Plug**



# Coil Headers, Locations Heating Only Units

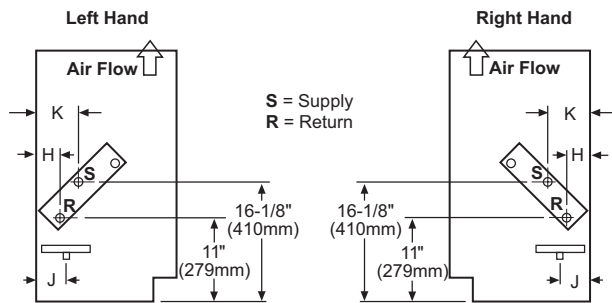
**Figure 41: Hot Water Only Unit (Coils 65, 66, 67)**

**Note:** This arrangement available on AVV and AVS units only.



**Figure 42: Steam Heating Only Unit (Coils 68, 69, 78, 79)**

**Note:** This arrangement available on AVV and AVS units only.

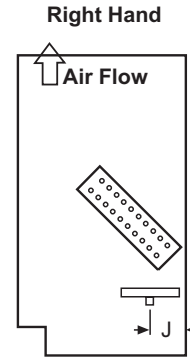


**Notes:**

1. All coils have same end supply and return connections.
2. Steam coils have a factory installed pressure equalizing valve and a 24" (610mm) long pressure equalizing line which terminates in a 1/2" M.P.T. fitting.
3. Steam/hot water connections may be same end as cooling coil connections, but they are recommended to be opposite end to facilitate piping. (Must be opposite end when using Daikin Applied controls.)
4. Cooling condensate drain pan is shipped sloped down towards the cooling coil connections but is field reversible.
5. Electric heating coil power connections are right end only. Junction box has 1" (25mm) and 2" (51mm) (trade size) knockouts, 10-1/2" (267mm) from right end of the unit.
6. Coil stubs are 7/8" I.D. (female) and terminate 9" (229mm) from the end of the unit.
7. Steam coils are 1-1/8" female (sweat) connections and terminate 9" (229mm) from the end of the unit.
8. DX coils (G[9] and M[0]) have O.D. sweat connections. Interconnecting tube by others. See table 7 for correct tubing size.

**Figure 43: Electric Heating Only Unit (Coils 12, 13)**

**Note:** This arrangement available on AVV units only.



**Table 5: Coil Connection Dimensions For Lettered Values**

Unit Depth		Dimensions				
		A	B	H	J	K
in.	16-5/8	3-3/4	12-1/4	2-7/8	3	5
mm	422	95	311	73	76	127
in.	21-7/8	9	17-1/2	8-1/8	8-1/4	10-1/4
mm	556	229	445	206	210	260

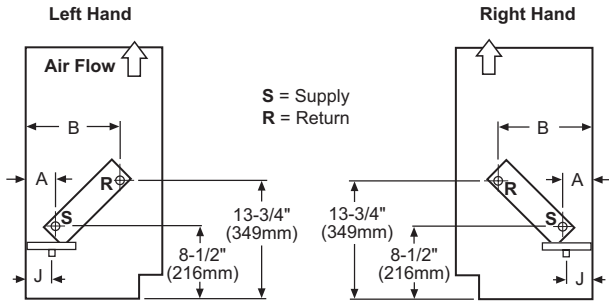


## Coil Headers, Locations (continued)

### Cooling Only Units

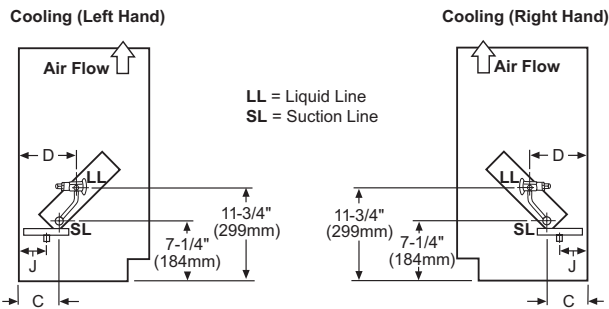
**Figure 44: Chilled Water Only Unit (Coils V[5], S[6], W[7], Y[8])**

**Note:** This arrangement available on AVV and AVS units only.



**Figure 45: Direct Expansion Cooling Only Unit (Coils G[9], M[0])**

**Note:** This arrangement available on AVV units only.



**Notes:**

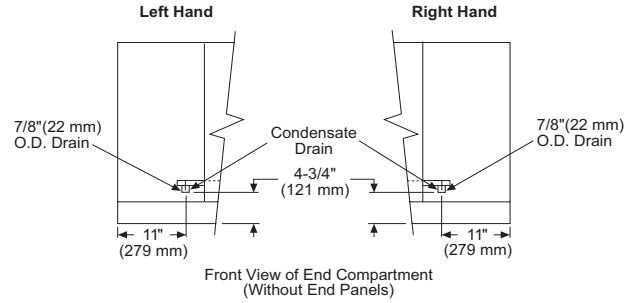
1. All coils have same end supply and return connections.
2. Steam coils have a factory installed pressure equalizing valve and a 24" (610mm) long pressure equalizing line which terminates in a 1/2" M.P.T. fitting.
3. Steam/hot water connections may be same end as cooling coil connections, but they are recommended to be opposite end to facilitate piping. (Must be opposite end when using Daikin Applied controls.)
4. Cooling condensate drain pan is shipped sloped down towards the cooling coil connections but is field reversible.
5. Electric heating coil power connections are right end only. Junction box has 1" (25mm) and 2" (51mm) (trade size) knockouts, 10-1/2" (267mm) from right end of the unit.
6. Coil stubs are 7/8" I.D. (female) and terminate 9" (229mm) from the end of the unit.
7. Steam coils are 1-1/8" female (sweat) connections and terminate 9" (229mm) from the end of the unit.
8. DX coils (G[9] and M[0]) have O.D. sweat connections. Interconnecting tube by others. See Table 7 for correct tubing size.

**Table 7: DX Coil (G[9] and M[0]) Connection Tubing**

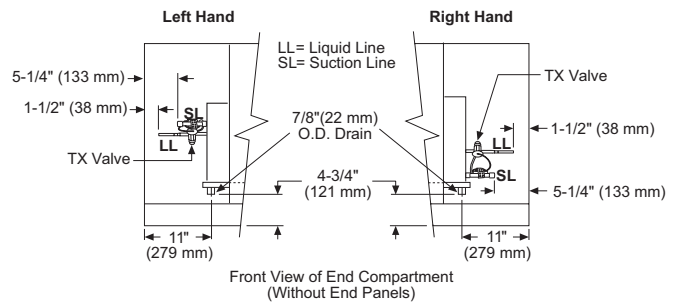
Unit Series	S07		S10		S13		S15	
	in	mm	in	mm	in	mm	in	mm
Suction Line OD:	3/4	19	3/4	19	7/8	22	7/8	22
Liquid Line OD:	1/4	6.35	1/4	6	3/8	10	3/8	10

## Condensate Drain Locations

**Figure 46: Condensate Drain**



**Figure 47: Condensate Drain and DX Coil Connections**



**Table 6: Coil Connection Dimensions For Lettered Values**

Unit Depth	Dimensions					
	A	B	C	D	J	
in.	16-5/8	3-3/4	12-1/4	4-7/8	7-3/4	3
mm	422	95	311	124	198	76
in.	21-7/8	9	17-1/2	10-1/8	13	8-1/4
mm	556	229	445	257	330	210

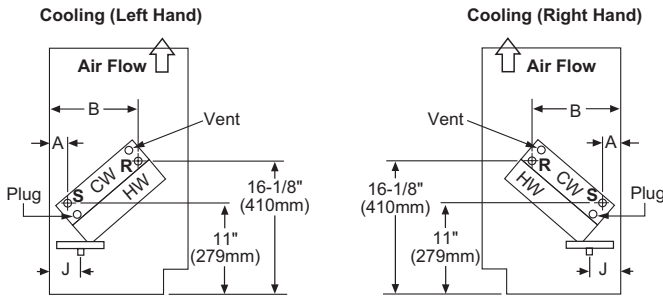
## Coil Headers, Locations (continued)

### Heat/Cool Units

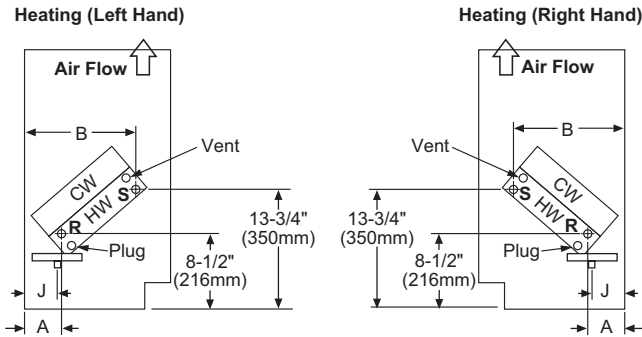
**Note:** Numerical codes [#] denote optional stainless steel drain pan (cooling coils).

### Chilled Water and Hot Water Unit

**Figure 48: Chilled Water Cooling Coils V[5], S[6], W[7], Y[8]**

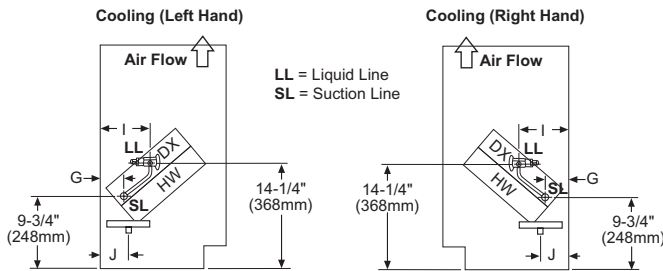


**Figure 49: Hot Water Heating Coils 65, 66, 67**

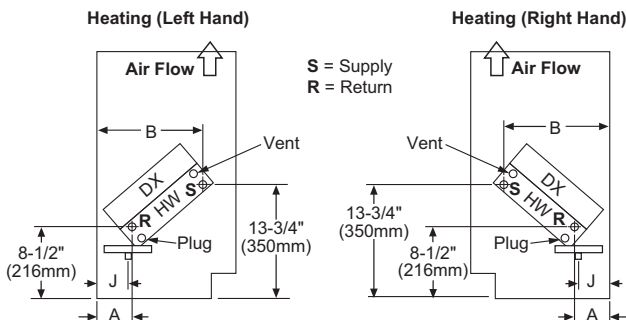


### Direct Expansion and Hot Water Unit

**Figure 50: Direct Expansion Cooling Coils G[9], M[0]**



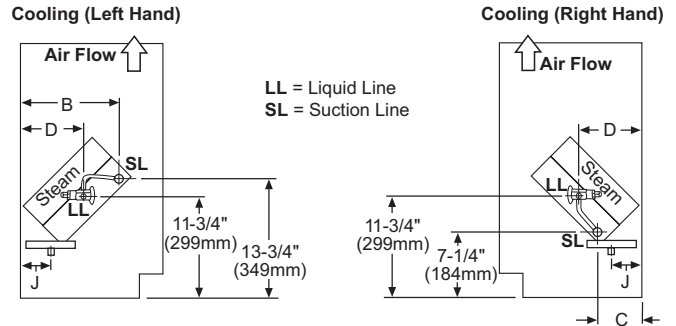
**Figure 51: Hot Water Heating Coils 65, 66, 67**



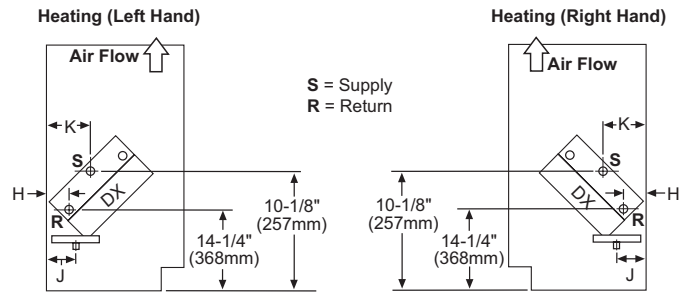
### Direct Expansion and Steam Unit

**Note:** For opposite end drain steam coils (code 78, 79) Return (R) is 7/4" (184mm) from bottom of unit and (H) 2" (51mm) from the back of unit. **Unless otherwise noted, LH and RH connections are the same.**

**Figure 52: Direct Expansion Cooling Coils G[9], M[0]**

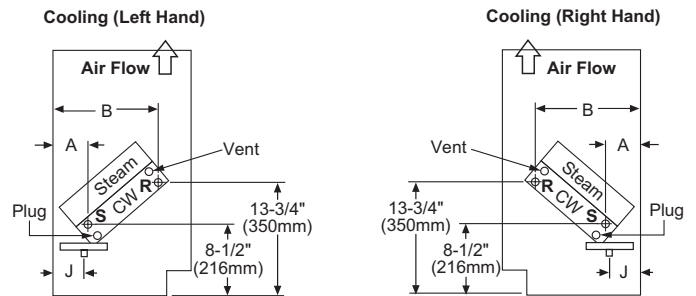


**Figure 53: Steam Heating Coils 68, 69, 78, 79**

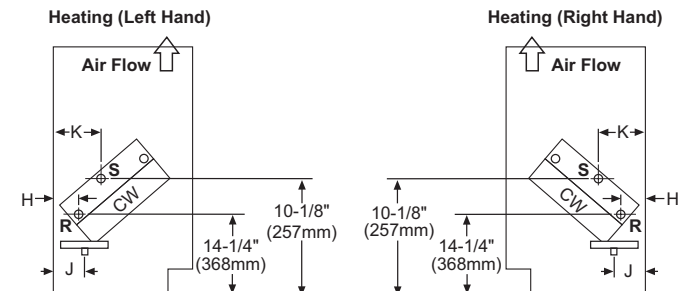


### Chilled Water and Steam Unit

**Figure 54: Chilled Water Cooling Coils V[5], S[6]**

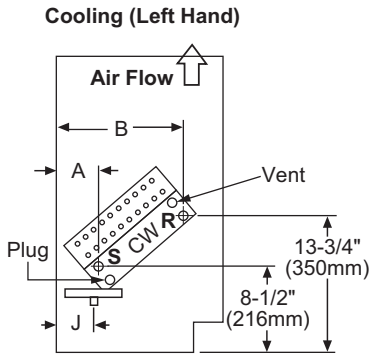


**Figure 55: Steam Heating Coils 68, 69, 78, 79**



### Chilled Water and Electric Heating Coils

Figure 56: Chilled Water (1st Position) and Electric Heating (Cooling Coils V[5], S[6], W[7]), (Heating Coils 12, 13)



### Direct Expansion and Electric Heating Unit

Figure 57: Direct Expansion (1st Position) and Electric Heating (Cooling Coils G[9], M[0]), (Heating Coils 12, 13)

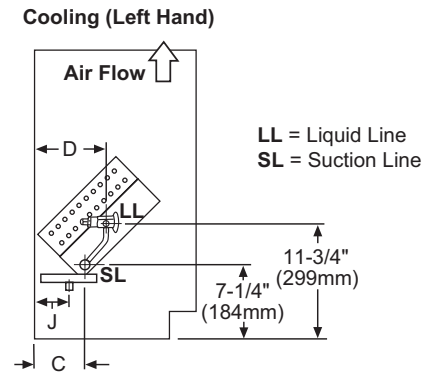


Table 8: Coil Connection Dimensions For Lettered Values<sup>1</sup>

Unit Depth		Dimensions										
		A	B	C	D	E	F	G	H	I	J	K
in.	16-5/8	3-3/4	12-1/4	4-7/8	7-3/4	1-5/8	10-1/8	2-3/4	2-7/8	5-5/8	3	5
mm	422	95	311	124	198	41	257	70	73	143	76	127
in.	21-7/8	9	17-1/2	10-1/8	13	6-7/8	15-3/8	8	8-1/8	10-7/8	8-1/4	10-1/4
mm	556	229	445	257	330	175	391	203	206	276	210	260

Table 9: Direct Expansion (DX) Coil G[9] and M[0] Connection Tubing

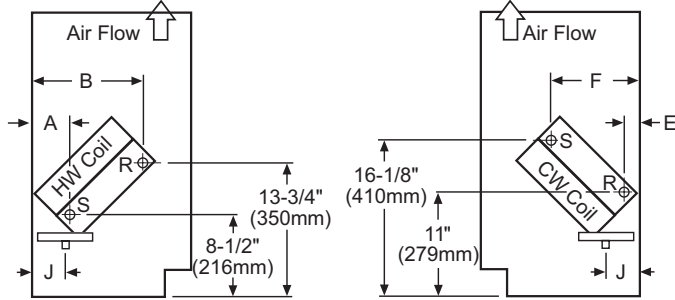
Unit Series	07		10		13		15	
	in	mm	in	mm	in	mm	in	mm
Suction Line OD:	3/4	19	3/4	19	7/8	22	7/8	22
Liquid Line OD:	1/4	6.35	1/4	6	3/8	10	3/8	10

## Reheat Units

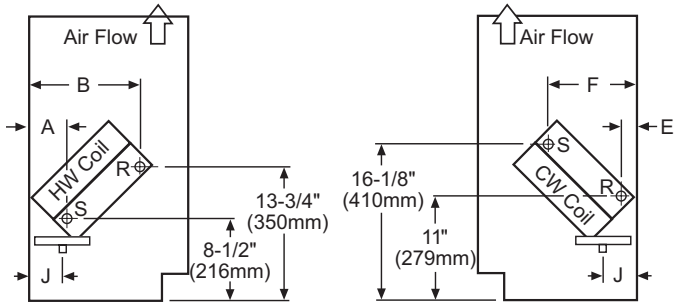
### Chilled Water and Hot Water Unit

**Note:** Numerical codes [#] denote optional stainless steel drain pan (cooling coils).

**Figure 58: Chilled Water Coils V[5], S[6], W[7], Y[8]**

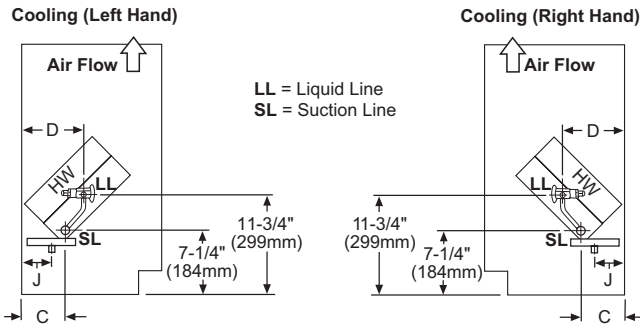


**Figure 59: Hot Water Heating Coils 65, 66, 67**

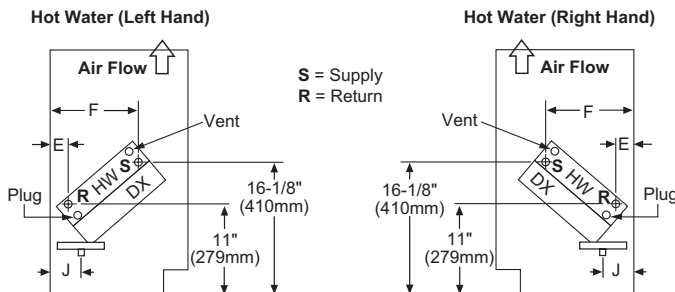


### Direct Expansion and Hot Water Unit

**Figure 60: Direct Expansion Cooling Coils G[9], M[0]**



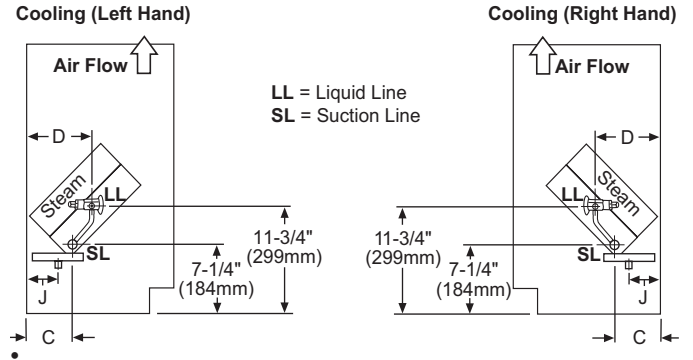
**Figure 61: Hot Water Heating Coils 65, 66, 67**



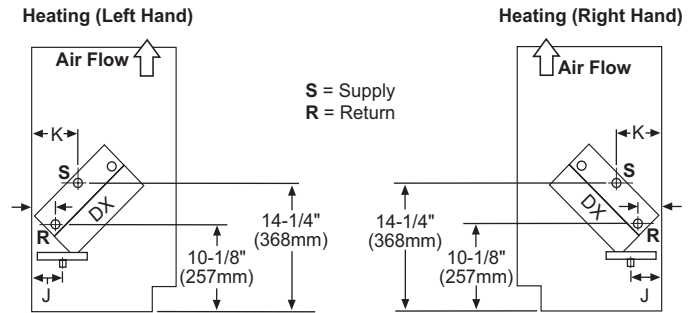
### Direct Expansion and Steam Unit

**Note:** For opposite end drain steam coils (code 78, 79) Return (R) is 7/4" (184mm) from bottom of unit and (H) 2" (51mm) from the back of unit. **Unless otherwise noted, LH and RH connections are the same.**

**Figure 62: Direct Expansion Cooling Coils G[9], M[0]**

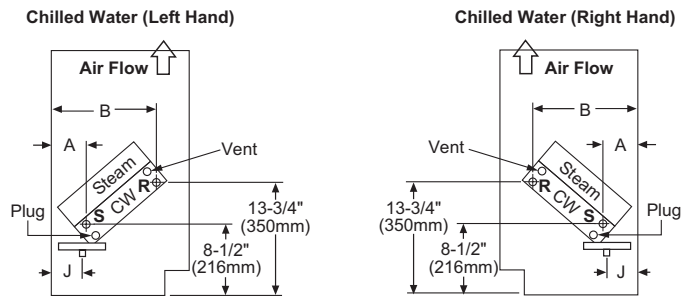


**Figure 63: Steam Heating Coils 68, 69, 78, 79**

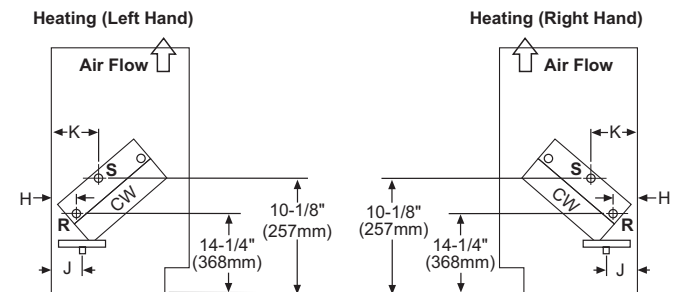


### Chilled Water and Steam Unit

**Figure 64: Chilled Water Coils V[5], S[6]**

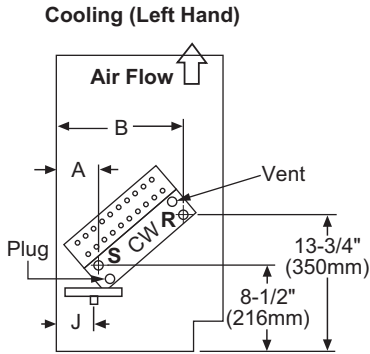


**Figure 65: Steam Heating Coils 68, 69, 78, 79**



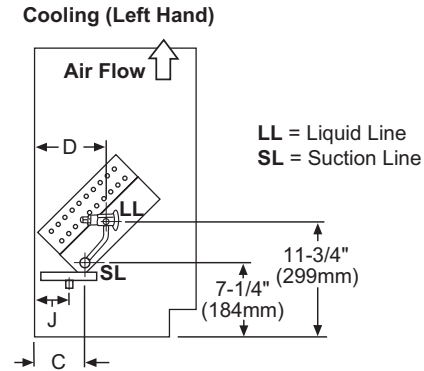
## Chilled Water and Electric Heating Coils

**Figure 66: Chilled Water (1st Position) and Electric Heating (Cooling Coils V[5], S[6], W[7]), (Heating Coils 12, 13)**



## Direct Expansion and Electric Heating Unit

**Figure 67: Direct Expansion (1st Position) and Electric Heating (Cooling Coils G[9], M[0]), (Heating Coils 12, 13)**



**Table 10: Coil Connection Dimensions For Lettered Values<sup>1</sup>**

Unit Depth		Dimensions										
		A	B	C	D	E	F	G	H	I	J	K
in.	16-5/8	3-3/4	12-1/4	4-7/8	7-3/4	1-5/8	10-1/8	2-3/4	2-7/8	5-5/8	3	5
mm	422	95	311	124	198	41	257	70	73	143	76	127
in.	21-7/8	9	17-1/2	10-1/8	13	6-7/8	15-3/8	8	8-1/8	10-7/8	8-1/4	10-1/4
mm	556	229	445	257	330	175	391	203	206	276	210	260

**Table 11: Direct Expansion (DX) Coil G[9] and M[0] Connection Tubing**

Unit Series	07		10		13		15	
	in	mm	in	mm	in	mm	in	mm
Suction Line OD:	3/4	19	3/4	19	7/8	22	7/8	22
Liquid Line OD:	1/4	6.35	1/4	6	3/8	10	3/8	10

## Typical Valve Packages

The optional factory-supplied Daikin Applied Control Valve(s) for water applications are either 2-way or 3-way type, and are shipped separate from the unit ventilator itself to help avoid shipping damage to the piping of the connection stub from the weight of the valve, and to provide the installer with maximum flexibility in making the field piping connection. Before proceeding, see Figure 68 through Figure 92 as applicable, as well as the job-specific piping drawings.

### Notes:

1. See label furnished on 2-way valve to determine direction of flow through the valve.
2. Adhere to the port orientation shown for the 3-way valve.
3. For hot water applications and chilled water/hot water (2-pipe) applications, the 2-way valve furnished is normally piped open to the coil; the 3-way valve is piped normally open to the coil.
4. For chilled water applications, the 2-way valve furnished is normally piped closed to the coil; the 3-way valve is piped normally closed to the coil.
5. The 3-way valve is generally selected for diverting water back to the return main, where a constant pump head pressure is required.
6. All water coil stubs are 7/8" I.D. female sweat. Coil connections terminate 9" (229mm) from the end of the unit. Hot water connections may be same end as cooling coil connections, but are recommended to be at opposite ends from each other. When using MicroTech controls, they must be at opposite ends.

## Face & Bypass End of Cycle Valves

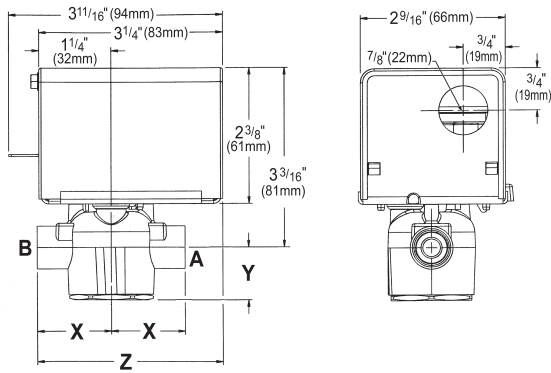
### 2-Way End of Cycle Valve



When piping the 2-Way End of Cycle valve, refer to label to determine the direction of flow. The valve should be installed so that there is a 2" (51mm) minimum clearance to remove the actuator from the valve body. Provide unions for removal of unit coil and/or control valve as a future service consideration. Hot water connections may be same end as cooling coil connections, but are recommended to be opposite end to facilitate piping.

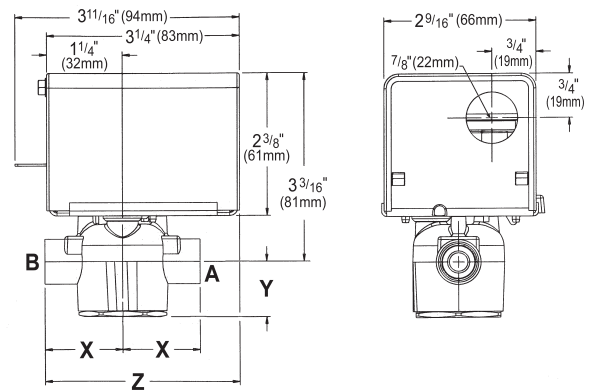
When using MicroTech® controls, they must be opposite end. The End of Cycle valve accessory must be field installed on the unit for which it was selected.

**Figure 68: 2-Way EOC Valve Dimensions**



Connection	Cv	X	Y	Z
3/4" (19mm) FNPT	7.5	1 11/16" (43mm)	1 5/16" (24mm)	3 5/8" (92mm)

**Figure 70: 2-Way EOC Steam Valve Dimensions**



Connection	Cv	X	Y	Z
1" (25mm) FNPT	8.0	1 1/8" (47mm)	1" (25mm)	3 11/16" (94mm)

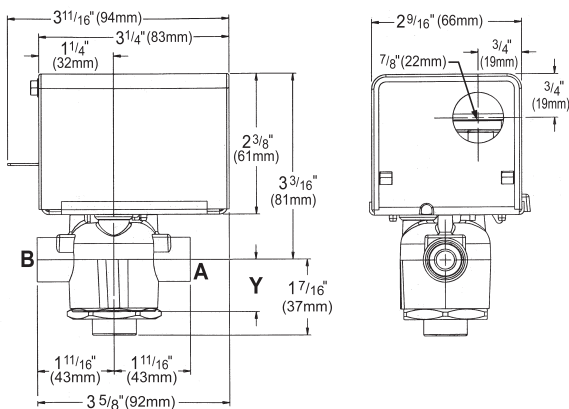
**3-Way End of Cycle Valve**



When piping the 3-Way End of Cycle valve, refer to label to determine the direction of flow. The valve should be installed so that there is a 2" (51mm) minimum clearance to remove the actuator from the valve body. Provide unions for removal of unit coil and/or control valve as a future service consideration. Hot water connections may be same end as cooling coil connections, but are recommended to be opposite end to facilitate piping.

When using MicroTech® controls, they must be opposite end. The End of Cycle valve accessory must be field installed on the unit for which it was selected.

**Figure 69: 3-Way EOC Valve Dimensions**



Connection	Cv	Y
3/4" (19mm) FNPT	5.0	1 5/16" (24mm)

**Table 12: EOC Actuator Specifications**

<b>Control</b>	2 Position
<b>Electrical</b>	24 VAC, 50/60 Hz
<b>Stroke</b>	Power Stroke 9 to 11 seconds Spring return 4 to 5 seconds
<b>Ambient</b>	32°F to 125°F (0°C to 52°C)

**Table 13: F&BP EOC Valve Body Specifications**

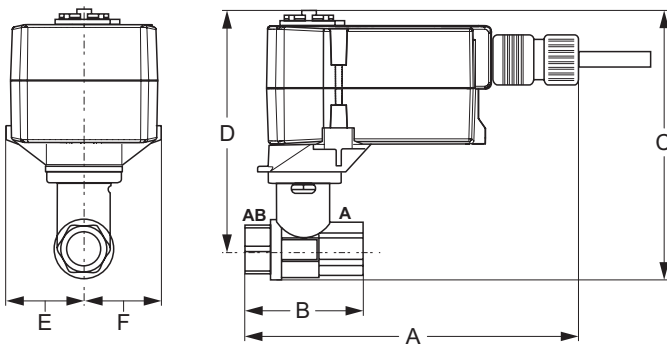
	2-Way Valve	3-Way Valve
<b>Connections</b>	3/4" FNPT, 1" FNPT	3/4" FNPT
<b>Static Pressure</b>	300 psi (2100 kPa)	300 psi (2100 kPa)
<b>Close-Off Pressure</b>	13 & 15 psi (90 & 103 kPa)	13 psi (90 kPa)
<b>Temperature</b>	32°F to 200°F (0°C to 93°C)	32°F to 200°F (0°C to 93°C)

## 2-Way Modulating Valve (Chilled Water, Hot Water or Combination)



Two-way modulating control valves for MicroTech are designed to regulate the flow of chilled water, hot water or the combination. They consist of a nickel plated brass body and stainless steel ball valve and stem, with a spring return proportional actuator. The optional valve accessory is shipped separate from the unit ventilator for field installation to prevent shipping damage and to provide flexibility in making the field piping connection.

**Figure 71: 2-Way Modulating Valve Dimensions**



**Table 14: 2-Way Actuator Specifications (CW, HW, CW/HW)**

Power Supply	24 VAC, ±20%, 50/60 Hz, 24 VDC, ±10%
Electrical Connection	3ft [1m], 18 GA plenum cable with 1/2" conduit connector
Overload Protection	electronic throughout 0° to 95° rotation
Operating Range Y	2 to 10 VDC, 4 to 20 mA w/ ZG-R01 (500 Ω, 1/4 W resistor)
Input Impedance	100 k Ω for 2 to 10 VDC (0.1 mA), 500 Ω for 4 to 20 mA
Feedback Output U	2 to 10 VDC, 0.5 mA max
Angle of Rotation	Max. 95°, 90°
Position Indication	visual indicator, 0° to 95° (0° is full spring return position)
Running Time (Motor)	95 sec
Running Time (Fail-Safe)	<25 sec
Ambient Humidity	max. 95% RH non-condensing
Ambient Temperature Range	-22°F to 122°F [-30°C to 50°C]
Storage Temperature Range	-40°F to 176°F [-40°C to 80°C]

**Table 15: 2-Way Valve Body Specifications (CW, HW, CW/HW)**

Service	chilled, hot water, up to 60% glycol
Flow Characteristic	equal percentage
Controllable Flow Range	75°
Body Pressure Rating [psi]	600
Media Temperature Range (Water)	0°F to 250°F [-18°C to 120°C]
Max Differential Pressure (Water)	50 psi (345 kPa)
Close-Off Pressure	200 psi

**Table 16: 2-Way Modulating Valve 1/2" – Dimensions (CW, HW, CW/HW)**

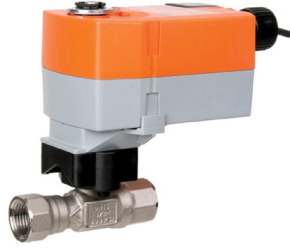
Valve Part No.	Cv	Connection Size (inches)	A	B	C	D	E	F
B209	0.8	1/2"	6.59" (167mm)	2.38" (60mm)	4.9" (124mm)	4.32" (110mm)	1.53" (38mm)	1.53" (38mm)
B210	1.2							
B211	1.9							
B212	3.0		6.59" (167mm)	2.38" (60mm)	5.48" (139mm)	4.71" (120mm)	1.53" (38mm)	
B213	4.7							
B214	7.4							

**Table 17: 2-Way Modulating Water Valve 1/2" – Pressure Drop (CW, HW, CW/HW)**

2-Way CCV Part No.	Cv Maximum Rating	Connection Size	Pressure Drop Across the Valve									
			1 PSI	2 PSI	3 PSI	4 PSI	5 PSI	6 PSI	7 PSI	8 PSI	9 PSI	10 PSI
B209	0.8	1/2"	0.8	1.1	1.4	1.6	1.8	2.0	2.1	2.3	2.4	2.5
B210	1.2		1.2	1.7	2.1	2.4	2.8	2.9	3.2	3.4	3.6	3.8
B211	1.9		1.9	2.7	3.3	3.8	4.2	4.7	5.0	5.4	5.7	6.0
B212	3.0		3.0	4.2	5.2	6.0	6.8	7.3	7.9	8.5	9.0	9.5
B213	4.7		4.7	6.6	8.1	9.4	11	12	12	13	14	15
B214	7.4		7.4	10	13	15	17	18	20	21	22	23

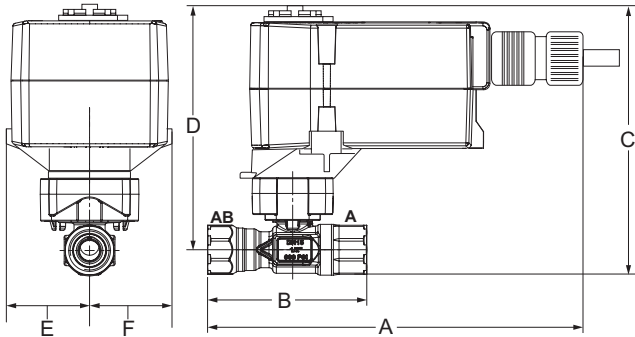


## 2-Way Modulating Valve (Steam) - 1/2"



Two-way modulating control valves for MicroTech are designed to regulate the flow of steam. They consist of a nickel plated brass body and stainless steel ball valve and stem, with a spring return, proportional actuator. The optional valve accessory is shipped separate from the unit ventilator for field installation to prevent shipping damage and to provide flexibility in making the field piping connection.

**Figure 72: 2-Way Modulating Valve (Steam) Dimensions**



**Table 18: 2-Way Actuator Specifications (Steam) – 1/2"**

Power Supply	24 VAC ± 20%, 50/60 Hz, 24 VDC ± 10%
Electrical Connection	3ft [1m], 18 GA plenum cable with 1/2" conduit connector"
Overload Protection	electronic throughout 0° to 95° rotation
Operating Range Y	2 to 10 VDC, 4 to 20 mA w/ ZG-R01 (500 Ω, 1/4 W resistor)
Input Impedance	100 k Ω for 2 to 10 VDC (0.1 mA), 500 Ω for 4 to 20 mA
Feedback Output U	2 to 10 VDC, 0.5 mA max
Angle of Rotation	Max. 95°, 90°
Position Indication	visual indicator, 0° to 95° (0° is full spring return position)
Running Time (Motor)	95 sec
Running Time (Fail-Safe)	<25 sec
Ambient Humidity	max. 95% RH non-condensing
Ambient Temperature Range	-22°F to 122°F [-30°C to 50°C]
Storage Temperature Range	-40°F to 176°F [-40°C to 80°C]

**Table 19: Valve Body Specifications (Steam) – 1/2"**

Service	high temperature hot water/low pressure steam, up to 60% glycol
Flow Characteristic	A-port equal percentage
Controllable Flow Range	75°
Body Pressure Rating [psi]	600
Max Inlet Pressure (Steam)	15 psi
Media Temperature Range (Water)	60°F to 266°F [16°C to 130°C]
Media Temperature Range (Steam)	250°F [120°C]
Maximum Differential Pressure (Steam)	15 psi
Max Differential Pressure (Water)	60 psi partially open ball, 116 psi full open
Close-Off Pressure	200 psi

**Table 20: 2-Way Modulating Steam Valve 1/2" – Dimensions**

Valve Part No.	Cv	Connection Size (inches)	A	B	C	D	E	F
B215HT073	0.73	1/2"	7.32" (186mm)	3.33" (85mm)	5.8" (147mm)	5.3" (135mm)	1.52" (39mm)	1.52" (38.5mm)
B215HT186	1.86							

**Table 21: 2-Way Modulating Steam Valve 1/2" – Pressure Drop**

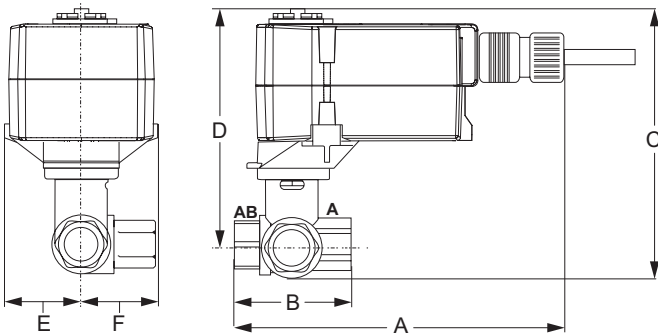
2-Way CCV Part No.	Cv Maximum Rating	Connection Size	Pressure Drop Across the Valve					
			2 PSI	3 PSI	4 PSI	5 PSI	10 PSI	15 PSI
B215HT073	0.73	1/2"	10.99	13.71	16.11	18.33	28.03	36.74
B215HT186	1.86		22.34	34.93	41.06	46.70	71.42	93.60

**3-Way Modulating Valve (Chilled Water, Hot Water or Combination)**



Three-way modulating control valves for MicroTech are designed to regulate the flow of hot or chilled water or the combination. They consist of a nickel plated brass body and stem with chrome plated brass ball valve, with a spring return, proportional actuator. The optional valve accessory is shipped separate from the unit ventilator for field installation to prevent shipping damage and to provide flexibility in making the field piping connection.

**Figure 73: 3-Way Modulating Valve (Chilled Water, Hot Water or Combination) Dimensions**



**Table 24: 3-Way Modulating Valve 1/2" – Dimensions**

Valve Part No.	Cv	Connection Size (inches)	A	B	C	D	E	F
B309(B)	0.8	1/2"	6.59" (167mm)	2.38" (60mm)	4.9" (124mm)	4.32" (110mm)	1.53" (38mm)	1.2" (31mm)
B310(B)	1.2							
B311(B)	1.9							
B312(B)	3.0							
B313(B)	4.7		6.59" (167mm)	2.38" (60mm)	4.9" (124mm)	4.71" (120mm)	1.53" (38mm)	1.29" (33mm)

**Table 25: Modulating 3-Way Hot Water, Chilled Water or 2-Pipe CW/HW Valve 1/2" – Pressure Drop**

3-Way CCV Part No.	Cv Maximum Rating	Connection Size	Pressure Drop Across the Valve									
			1 PSI	2 PSI	3 PSI	4 PSI	5 PSI	6 PSI	7 PSI	8 PSI	9 PSI	10 PSI
B309(B)	0.8	1/2"	0.8	1.	1.4	1.6	1.8	2.0	2.	2.3	2.4	2.5
B310(B)	1.2		1.2	1.7	2.	2.4	2.8	2.9	3.2	3.4	3.6	3.8
B311(B)	1.9		1.9	2.7	3.3	3.8	4.2	4.7	5.0	5.4	5.7	6.0
B312(B)	3.0		3.0	4.2	5.2	6.0	6.8	7.3	7.9	8.5	9.0	9.5
B313(B)	4.7		4.7	6.6	8.1	9.4	11	12	12	13	14	15

**Table 22: 3-Way Actuator Specifications (CW, HW, CW/HW)**

Power Supply	24 VAC, ±20%, 50/60 Hz, 24 VDC, ±10%
Electrical Connection	3ft [1m], 18 GA plenum cable with 1/2" conduit connector
Overload Protection	electronic throughout 0° to 95° rotation
Operating Range Y	2 to 10 VDC, 4 to 20 mA w/ ZG-R01 (500 Ω, 1/4 W resistor)
Input Impedance	100 k Ω for 2 to 10 VDC (0.1 mA), 500 Ω for 4 to 20 mA
Feedback Output U	2 to 10 VDC, 0.5 mA max
Angle of Rotation	Max. 95°, 90°
Position Indication	visual indicator, 0° to 95° (0° is full spring return position)
Running Time (Motor)	95 sec
Running Time (Fail-Safe)	<25 sec
Ambient Humidity	max. 95% RH non-condensing
Ambient Temperature Range	-22°F to 122°F [-30°C to 50°C]
Storage Temperature Range	-40°F to 176°F [-40°C to 80°C]

**Table 23: 3-Way Valve Body Specifications (CW, HW, CW/HW)**

Service	chilled, hot water, up to 60% glycol
Flow Characteristic	A-port Equal percentage; B-port modified linear for constant flow
Controllable Flow Range	75°
Body Pressure Rating [psi]	600
Media Temperature Range (Water)	0°F to 250°F [-18°C to 120°C]
Max Differential Pressure (Water)	50 psi (345 kPa)
Close-Off Pressure	200 psi

## Steam Modulating Valve Selection

The steam modulating control valve is expected to vary the quantity of steam through the coil. Any movement of the valve stem should produce some change in the steam flow rate. To select a modulating steam valve:

1. Obtain the supply steam inlet pressure.
2. Determine the actual heat requirement of the space to be heated.

**Table 26: Modulating 2-Way, Normally Open, Steam Valves – Pressure Drop**

2-Way CCV Part No.	Cv Maximum Rating	Connection Size	Pressure Drop Across the Valve					
			2 PSI	3 PSI	4 PSI	5 PSI	10 PSI	15 PSI
B215HT073	0.73	1/2"	10.99	13.71	16.11	18.33	28.03	36.74
B215HT186	1.86		22.34	34.93	41.06	46.70	71.42	93.60

## 2-Way and 3-Way Hot Water and Chilled Water Modulating Valve Selection

The unit ventilator control valve is expected to be able to vary the quantity of water that flows through the coil in a modulating fashion. Any movement of the valve stem should produce some change in the amount of water that flows through the coil. Oversized control valves cannot do this. For example, assume that when the control valve is fully open, the pressure drop through the coil is twice as great as the drop through the valve. In this case, the control valve must travel to approximately 50% closed before it can begin to have any influence on the water flow through the coil. The control system, no matter how sophisticated, cannot overcome this. Oversized control valves can also result in “hunting” which will shorten the life of the valve and actuator and possibly damage the coil.

To correctly select the proper Chilled Water Modulating Valve:

1. Determine the flow of water and the corresponding pressure drop through the coil.
2. Obtain the pressure difference between the supply and return mains.
3. Select a valve size (Cv) from [Table 26](#), on the basis of taking 50% of the available pressure difference (at design flow) between the supply and return mains at the valve location. The valve should have a pressure drop greater than that of the coil.

## Formula Equation to Calculate Cv

Q = Capacity in gallons per minute

Cv = Valve sizing coefficient determined experimentally for each style and size of valve, using water at standard conditions as the test fluid

ΔP = Pressure differential in psi

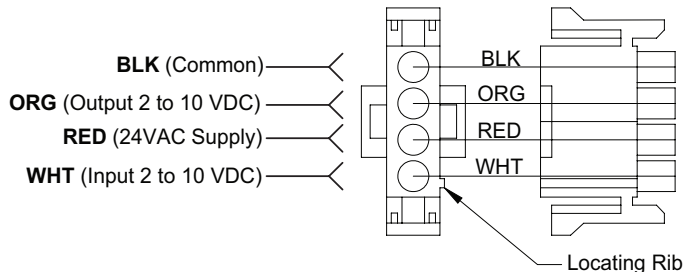
G = Specific gravity of fluid (water at 60°F = 1.0000)

$$Cv = Q \sqrt{\frac{G}{\Delta P}}$$

**⚠ CAUTION**

Care must be taken with modulating valves to provide proper water flow. In freezing conditions, water flow must be maintained through the heating coil or a suitable freeze-prevention solution employed to prevent freeze-up. Similarly, the cooling coil must be drained or a suitable freeze-prevention solution employed.

**Figure 74: Actuator Wiring**



**Note:** The actuator spring returns the valve to the open position when the actuator is de-energized (off).

# Typical Piping Arrangements

Heating valve actuators should be mounted in an upright position above the centerline of the valve body and should be piped normally open to the coil. Modulating valve actuators for hot water applications may be positioned above the valve body a maximum of 75 degrees from the vertical. For steam applications only, mount the modulating valve actuator above the valve body at 45 degrees from the vertical. Two-position, end-of-cycle (EOC) valves used with face and bypass damper controlled units may be positioned above the valve body a maximum of 85 degrees from the vertical.

All control valves are shipped loose to help avoid shipping damage to the piping or the coil connection stub from the weight of the valve, and to provide the installing contractor with maximum flexibility in making the field piping connections. Refer to Daikin Applied factory instruction sheet shipped with the unit for port orientation and a piping schematic.

Control valves must be installed on the units in which they are shipped. Indiscriminate mixing of valves among units can result in valves not properly sized for the desired flow rate. Refer to label to determine the direction of flow. Control valves should be installed so that there is 2" (51mm) minimum clearance to remove the actuator from the valve body. As a future service consideration, provide unions for removal of the unit coil and/or the control valve. Hot water connections may be same end as cooling coil connections, but are recommended to be opposite end to facilitate piping.

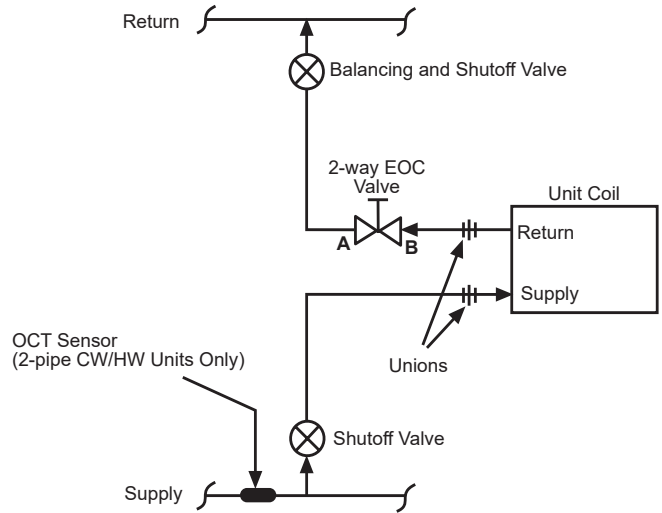
When using MicroTech® controls, they must be opposite end. The End of Cycle valve must be field installed on the unit for which it was selected.

## Heating – Hot Water End of Cycle Valve Piping

### 2-Way End of Cycle, Normally Open, Hot Water or 2-pipe CW/HW Valve Piping (typical)

The 2-way End of Cycle hot water (or 2-pipe CW/HW) valve is furnished normally open to the coil. When the valve is de-energized (off) there is full flow through the coil. Energizing the valve shuts off the water flow.

**Figure 75: 2-Way Hot Water EOC Valve Piping**

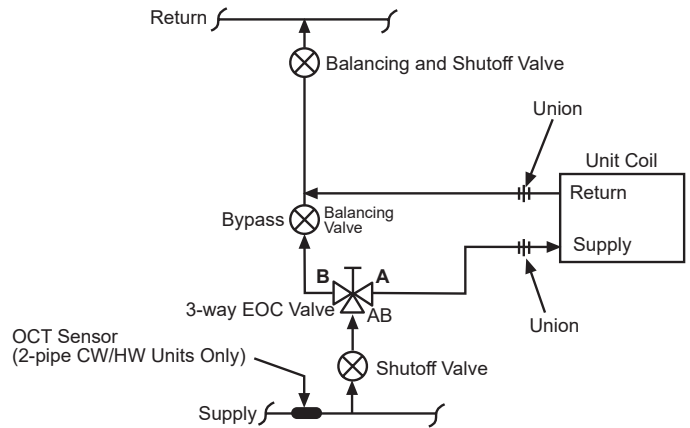


**Note:** For Erie E.O.C. water valves, always have the direction of water flow piped to the B-port of the valve.

### 3-Way End of Cycle, Normally Open, Hot Water or 2-pipe CW/HW Valve Piping (typical)

The 3-way End of Cycle hot water (or 2-pipe CW/HW) valve is furnished normally open to the coil. When the valve is de-energized (off) there is full flow through the coil. Energizing the valve allows the water to bypass the coil.

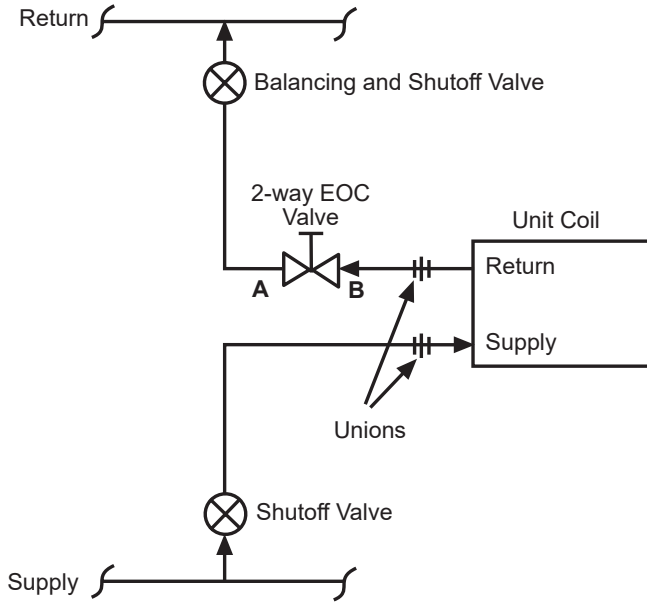
**Figure 76: 3-Way Hot Water EOC Valve Piping**



## Chilled Water EOC Valve Piping 2-Way End of Cycle, Normally Closed, Chilled Water Valve Piping (typical)

The 2-way EOC CW valve is furnished normally closed to the coil. When the valve is de-energized (off) there is no flow through the coil. Energizing the valve allows flow through the coil.

**Figure 77: 2-Way Chilled Water EOC Valve Piping**

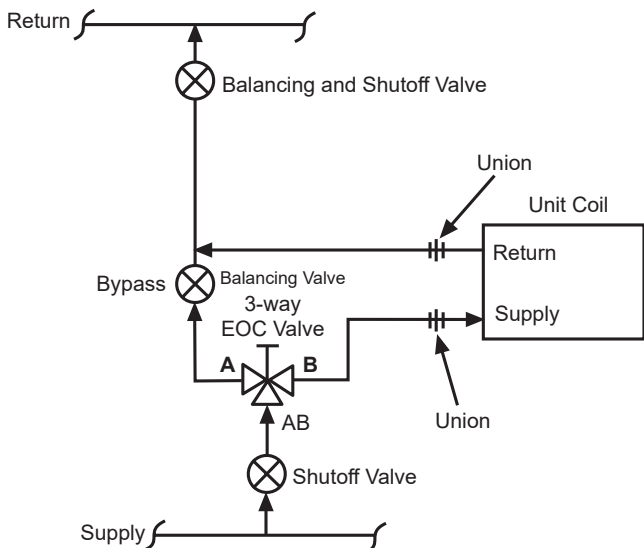


**Note:** For Erie E.O.C. water valves, always have the direction of water flow piped to the B-port of the valve.

## 3-way End of Cycle, Normally Closed, Chilled Water Valve Piping (typical)

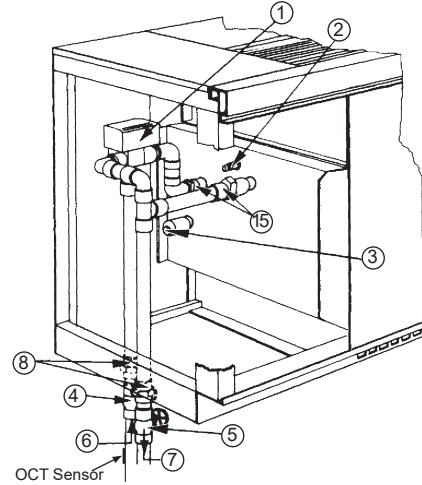
The 3-way EOC CW valve is furnished normally closed to the coil. When the valve is de-energized (off) the flow bypasses the coil. Energizing the valve allows flow through the coil.

**Figure 78: 3-Way Chilled Water EOC Valve Piping**

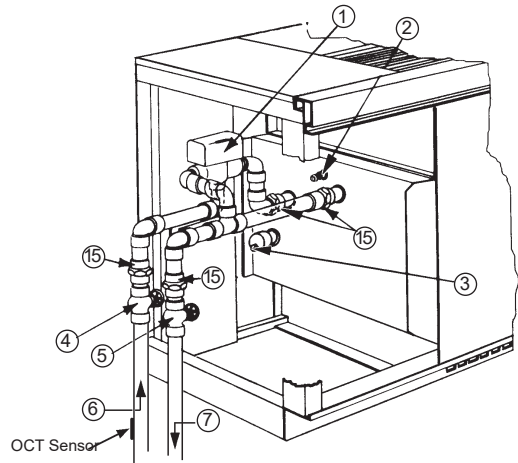


## Typical Water Coil Piping - EOC Valve Piping

**Figure 79: Face and Bypass With 3-Way End-of-Cycle Valve (Piping Within Unit End Compartment)**



**Figure 80: Face and Bypass With 3-Way End-of-Cycle Valve (Piping Outside Unit End Compartment)**



**Table 27: Number Descriptions for Figure 79 & Figure 80**

- 1 Three-way End of Cycle control valve (Daikin Applied)
- 2 Coil air vent (Daikin Applied)
- 3 Coil drain (Daikin Applied)
- 4 Shutoff valve (by others)
- 5 Balancing shutoff valve(s) (by others)
- 6 Supply
- 7 Return
- 8 Unions (by others), must disconnect below floor line
- 9 Two-way, End of Cycle two-position valve (Daikin Applied)
- 10 Union: Half attached to coil, half attached to valve
- 11 Modulating control valve (Daikin Applied)
- 12 All piping, fittings and unions by others (not Daikin Applied except as noted)
- 13 Steam check valve and pressure equalizing line (Daikin Applied)
- 14 Float and thermostatic steam trap (by others)
- 15 Supply and return coil connection and stub-up unions (by others)



## Steam – Typical Modulating Valve Piping

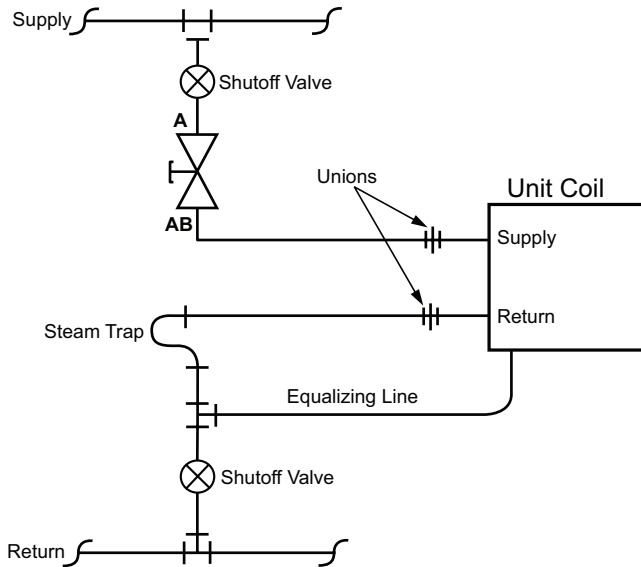
The optional factory supplied Daikin Applied controls with a 2-way Modulating steam valve is furnished normally open to the coil. When the valve is de-energized (off) there is full flow through the coil. Energizing the valve reduces the steam flow in a modulating fashion.

### CAUTION

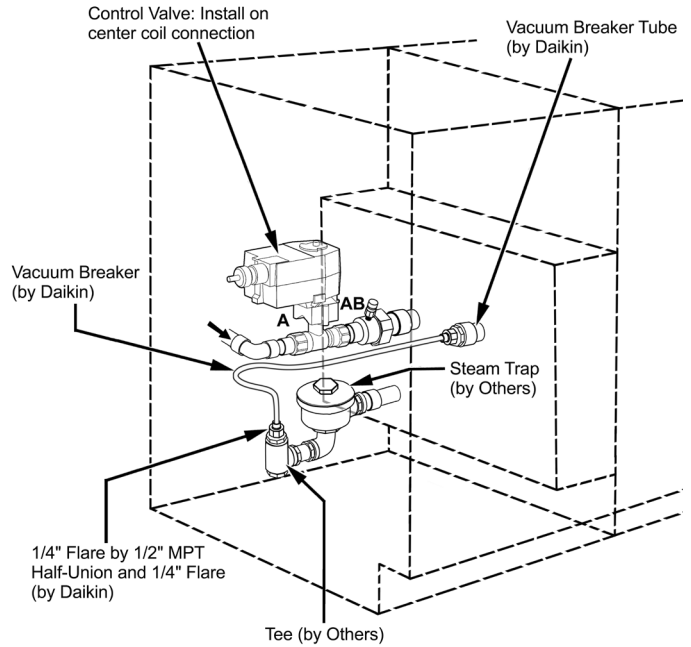
Refer to the arrow on the modulating valve body to determine the direction of flow. If the valve is mounted improperly, the unit will not operate properly and damage to the valve may result.

The valve should be installed so that there is a 2" (51mm) minimum clearance to remove the actuator from the valve body. Provide unions for removal of unit coil and/or control valve as a future service consideration. Steam connections may be same end as cooling coil connections, but are recommended to be opposite end to facilitate piping. When using Daikin Applied factory controls, they must be opposite end. The modulating valve accessory must be field installed on the unit for which it was selected.

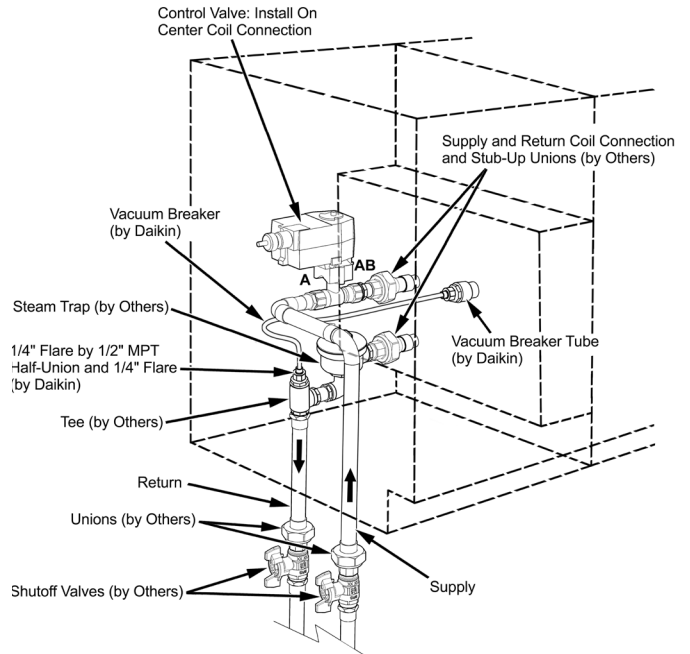
**Figure 81: Typical 2-Way Steam Modulating Valve Piping**



**Figure 82: Same End Connections – Model AV 68/69 Coils**



**Figure 83: 2-Way Steam Modulating Valve Control - Same End Drain Connection (Piping Within Unit End Compartment)**



### **In Steam Systems:**

The optional factory-supplied Daikin Applied controls Modulating Control Valve for steam applications is the 2-way type. It is shipped separately from the unit ventilator to help avoid shipping damage, yet provide the installer with maximum flexibility in making the field piping connection. Before proceeding, see [Figure 81 through Figure 86](#), as well as the job-specific piping drawings.

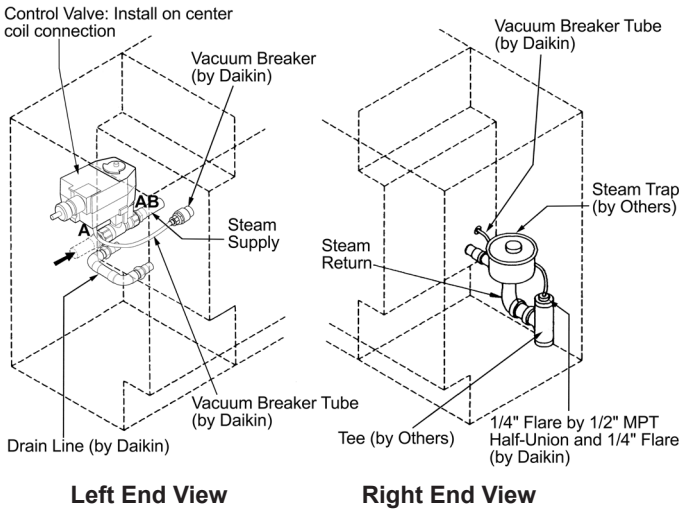
For steam applications, the 2-way, angle pattern valve furnished is normally piped open to the coil. All steam coils are 1-1/8" (34mm) female sweat connections. Coil connections terminate 9" (229mm) from the end of the unit.

Steam coils have a factory-installed pressure equalizing valve and a 24" (610mm) long pressure equalizing line that terminates in a 1/2" M.P.T. fitting.

Steam connections may be same end as cooling coil connections, but are recommended to be opposite end to facilitate piping. When using MicroTech controls, they must be opposite end.

See Figure 82 through Figure 86. Connect the 1/4" (6.35mm) vacuum breaker tube to the downstream return line. Make this connection downstream of the trap outlet.

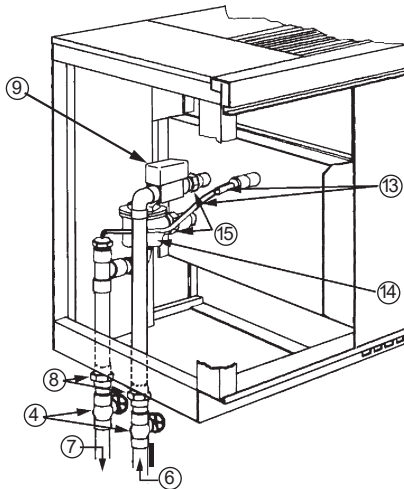
**Figure 84: Opposite End Drain Connection – (78/79 Coils)**



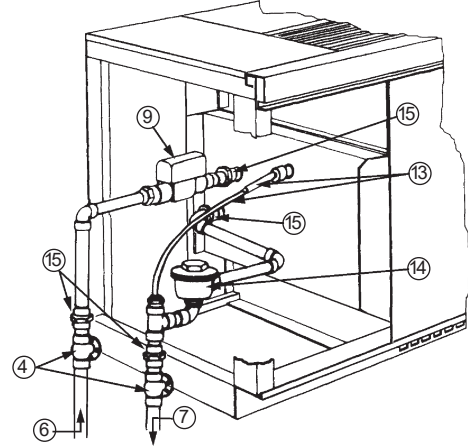
**Note:** Left Hand Steam Supply and Right Hand Steam Return (Shown)

## Typical Steam Coil Piping

**Figure 85: Face and Bypass With 2-Way End-of-Cycle Valve - Same End Drain Connection (Piping Within Unit End Compartment)**



**Figure 86: Face and Bypass With 2-Way End-of-Cycle Valve - Same End Drain Connection (Piping Outside Unit End Compartment)**

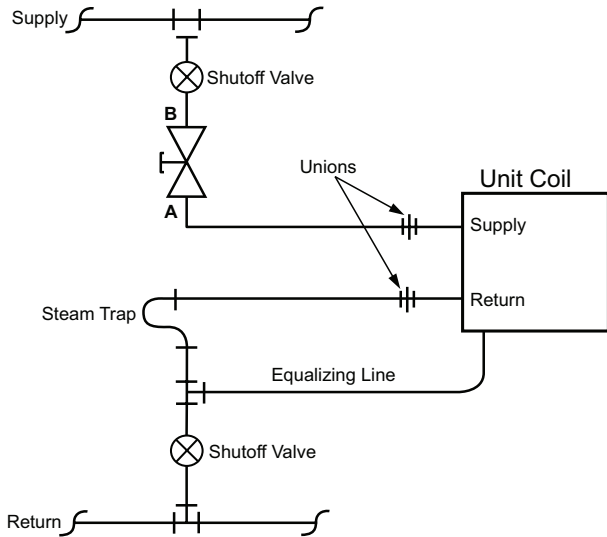


**Table 28: Number Descriptions for Figure 85 & Figure 86**

- 1 Three-way End of Cycle control valve (Daikin Applied)
- 2 Coil air vent (Daikin Applied)
- 3 Coil drain (Daikin Applied)
- 4 Shutoff valve (by others)
- 5 Balancing shutoff valve(s) (by others)
- 6 Supply
- 7 Return
- 8 Unions (by others), must disconnect below floor line
- 9 Two-way, End of Cycle two-position valve (Daikin Applied)
- 10 Union: Half attached to coil, half attached to valve
- 11 Modulating control valve (Daikin Applied)
- 12 All piping, fittings and unions by others (not Daikin Applied except as noted)
- 13 Steam check valve and pressure equalizing line (Daikin Applied)
- 14 Float and thermostatic steam trap (by others)
- 15 Supply and return coil connection and stub-up unions (by others)



**Figure 87: 2-Way Steam End of Cycle Valve Piping**



**Note:** For Erie EOC steam valves, always have the direction of steam flow piped to the **B** port of the valve. Actuator to be configured for **B** port to be normally open.

## Heating – Modulating Valve Piping Hot Water (or 2-pipe CW/HW) Modulating Valve Piping

When piping the modulating valve, refer to the arrows on the modulating valve body to determine the direction of flow. The valve should be installed so that there is a 2" (51mm) minimum clearance to remove the actuator from the valve body. Provide unions for removal of unit coil and/or control valve as a future service consideration. Hot water connections may be same end as cooling coil connections, but are recommended to be opposite end to facilitate piping. When using Daikin Applied MicroTech controls, they must be opposite end. The modulating valve accessory must be field installed on the unit for which it was selected.

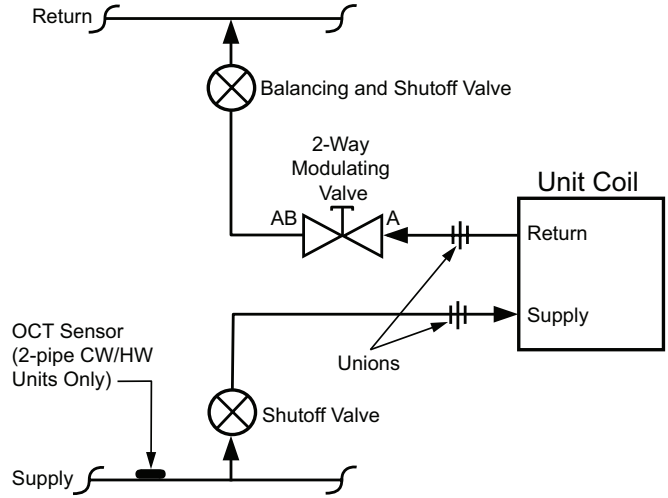
**⚠ CAUTION**

Refer to the arrow on the modulating valve body to determine the direction of flow. If the valve is mounted improperly, the unit will not operate properly and damage to the valve may result.

## 2-Way Modulating, Normally Open, Hot Water or 2-pipe CW/HW Valve Piping (typical)

The 2-way Modulating hot water (or 2-pipe CW/HW) valve is furnished normally open to the coil. When the valve is de-energized (off) there is full flow through the coil. Energizing the valve reduces the volume of water flow in a modulating fashion.

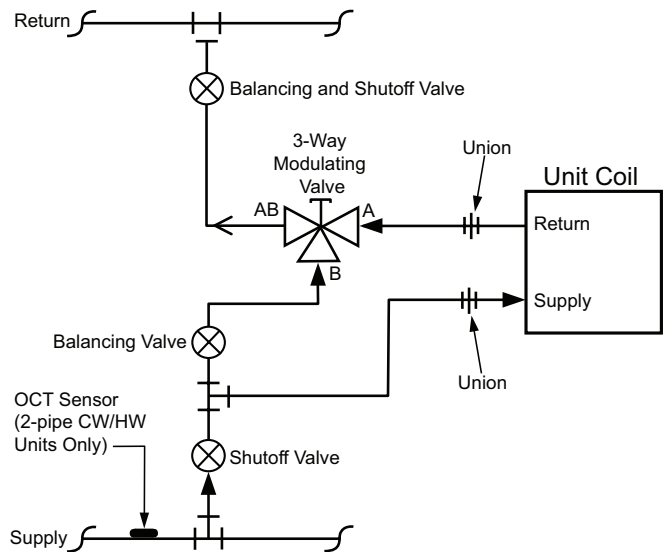
**Figure 88: 2-Way Modulating Valve Control, Normally Open, Hot Water or 2-pipe CW/HW Piping**



## 3-Way Modulating, Normally Open, Hot Water or 2-pipe CW/HW Valve Piping (typical)

The 3-way Modulating hot water (or 2-pipe CW/HW) valve is furnished normally open to the coil. When the valve is de-energized (off) there is full flow through the coil. Energizing the valve allows a varying amount of water to bypass the coil.

**Figure 89: 3-Way Modulating Valve Control**



**Note:** The **A** port is always piped to the coil. Actuator to be configured for **A** port to be Normally Open.

## Cooling – Chilled Water Modulating Valve Piping

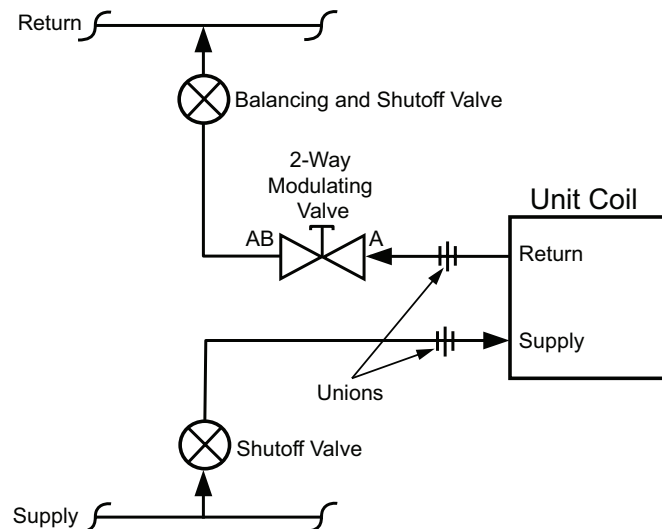
### 2-way Modulating, Normally Closed, Chilled Water Valve Piping (typical)

The 2-way Modulating chilled water valve is furnished normally closed to the coil. When the valve is de-energized (off) there is no flow through the coil. Energizing the valve allows flow through the coil in a modulating fashion.

**⚠ CAUTION**

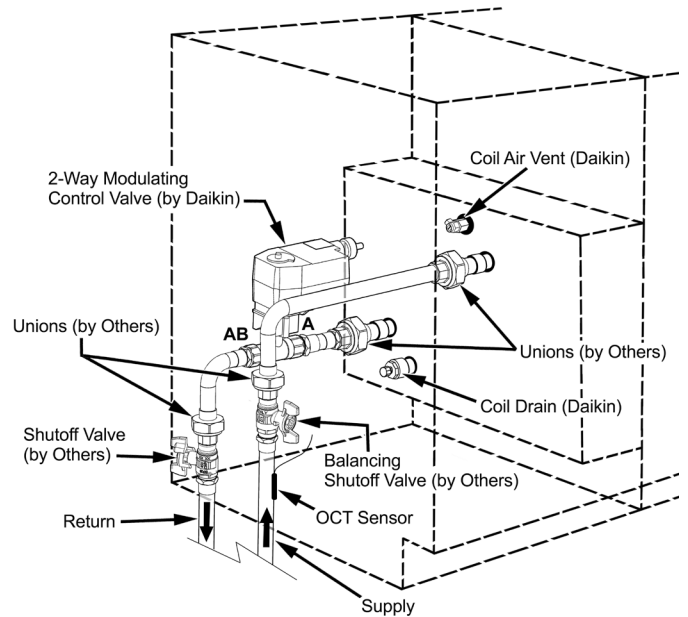
Refer to the arrow on the modulating valve body to determine the direction of flow. If the valve is mounted improperly, the unit will not operate properly and damage to the valve may result.

**Figure 90: 2-Way Modulating Valve Control, Normally Closed, Chilled Water Piping**



**Note:** Actuator to be configured for A port to be normally closed.

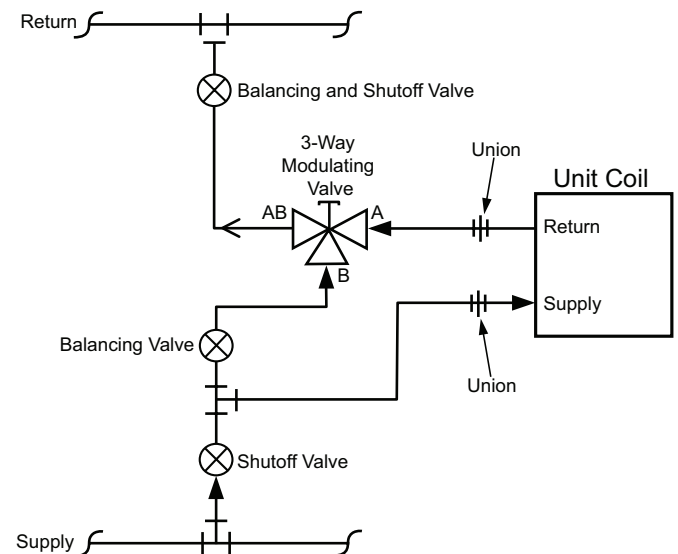
**Figure 91: 2-Way Modulating, Normally Closed Chilled Water Valve Piping**



### 3-Way Modulating, Normally Closed, Chilled Water Valve Piping (typical)

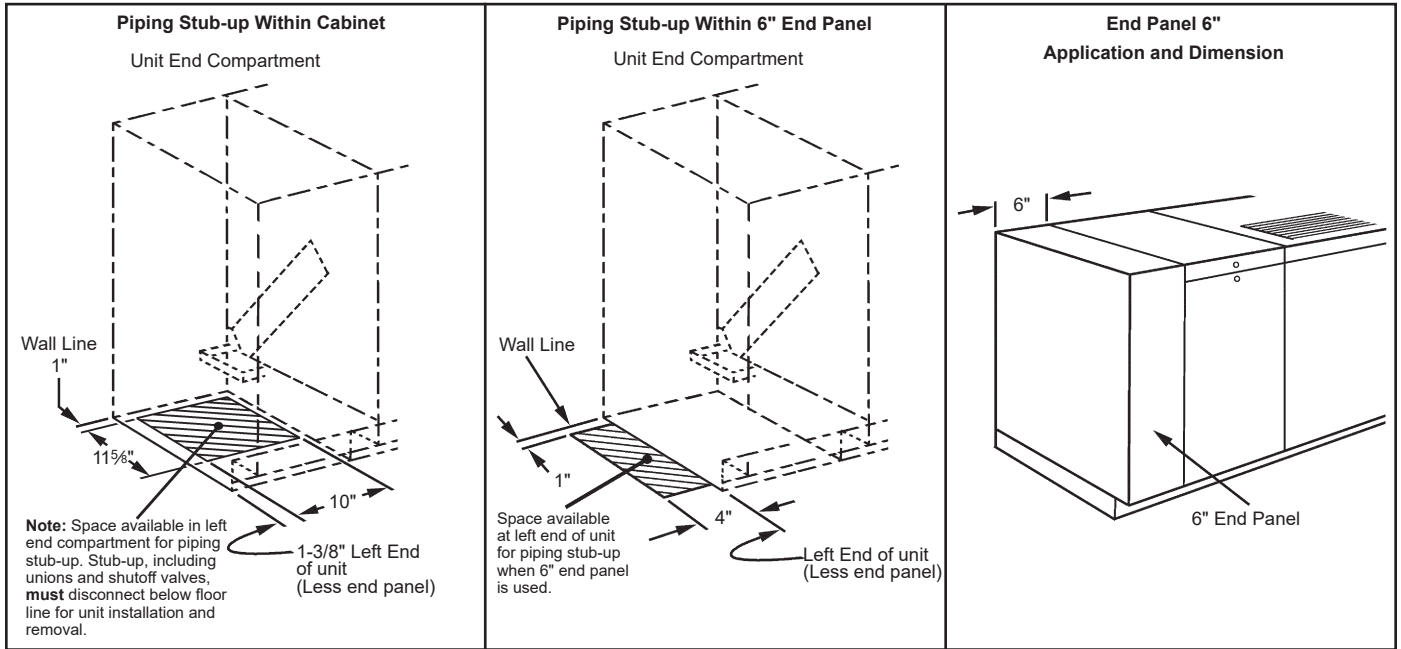
The 3-way Modulating chilled water valve is furnished normally closed to the coil. When the valve is de-energized (off) the flow bypasses the coil. Energizing the valve allows flow through the coil in a modulating fashion.

**Figure 92: 3-Way Modulating Valve Control, Normally Closed, Chilled Water Piping**



**Note:** The A port is always piped to the coil. Actuator to be configured for A port to be Normally Closed.

**Figure 93: Piping Stub-Up Details, 6" End Panel**



**Condensate Piping:**

Daikin Applied cooling unit ventilators are designed for condensate removal into a condensate disposal system. Do not connect the unit drain connection so that condensate exits to the outside and/or is exposed to freezing temperatures. Installer is responsible for any damage that might be caused from freezing condensate. In applications with an end compartment auxiliary drain pan, see the installation instructions shipped with the auxiliary drain pan itself.

**Direct-Expansion (DX) R-410 Piping**

DX coils have O.D. sweat connections. Interconnecting tubing is field-supplied. See [Table 29 on page 38](#) and job-specific drawings for correct tubing sizes.

**In Units with Optional TXV Bypass:**

The DX coil will have a TXV bypass installed to allow for split-system pairing with a heat pump condensing unit, to allow for field-supplied refrigerant heating.

**CAUTION**

Wrap TXV valve with a quenching cloth and remove bulb from suction line to avoid valve damage while brazing.

Proper ventilation is required for brazing. When brazing, be sure to protect unit ventilator components from overheating damage (melting insulation, also damage to valves, wiring, electronics, sensors, etc.).

During brazing, bleed nitrogen through the piping. Using field-supplied material suitable for insulating refrigerant lines, wrap the thermal expansion valve (TXV) bulb and the piping between the TXV and the point where it enters the coil with at least one thickness of the material. Likewise, insulate the suction line. (See [Figure 96](#) through [Figure 99](#) for typical piping and wiring)

Ensure proper insulation of supply and return piping. Proper insulation prevents loss of unit ventilator capacity, overheating of end compartment, and / or moisture dripping.

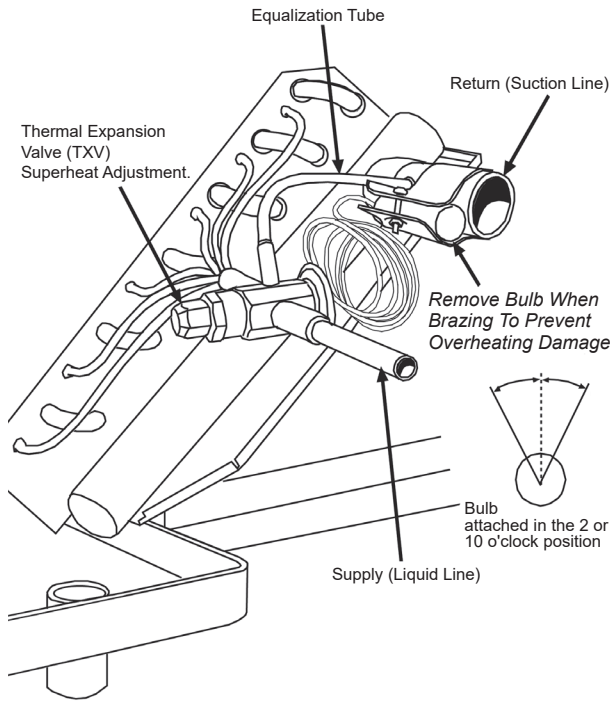
**NOTICE**

Ensure refrigerant pressure taps are installed in piping end compartment for proper charging and setting of the TXV valve.

**STOP! Before Brazing**

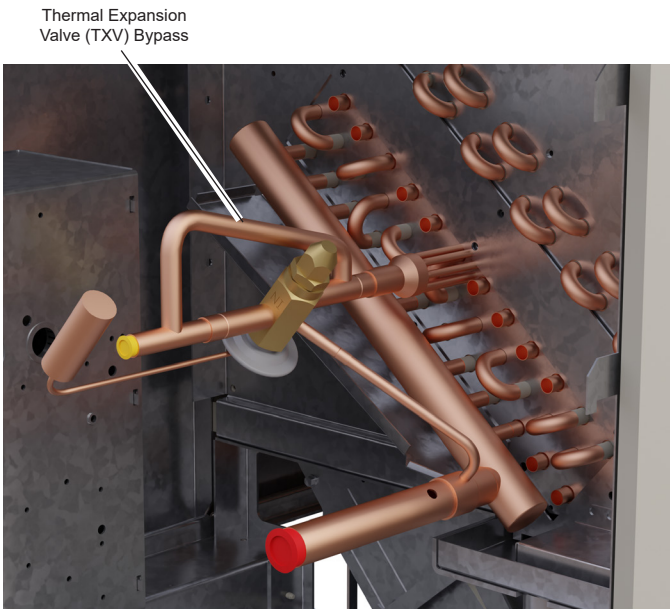
Use A Quenching Cloth When Brazing, to Prevent Overheating The TXV Valve Body (Avoid Valve Damage and Erratic Operation)

**Figure 94: TXV Valve Piping Detail (Left Hand Shown)**



**Note:** Install Pressure Taps on Supply (Liquid Line) and Return (Suction Line) Piping (By Others).

**Figure 95: Optional TXV Bypass Valve Piping Detail**



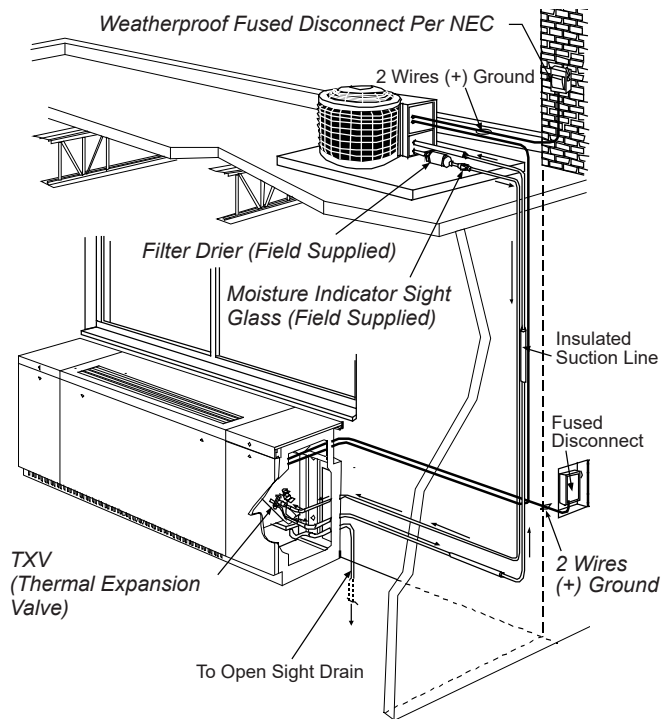
## Unit Ventilator Split Systems Guidelines

The following provides basic guidelines that will provide proper system cooling and operation of an R-410 commercial DX/hot water system for school applications. DX system components must be matched and sized correctly (not oversized) for the load.

The DX system must incorporate the following, provided by others, for proper operation:

- Size piping per ASHRAE Refrigeration Handbook (correct refrigerant and compressor oil flow), see [Table 29 on page 38](#).
- Use clean sealed refrigerant grade piping (prevent system contamination)
- Install Liquid Line Filter Dryer (clean/dry system to prevent damage of operating components), see [Figure 98 on page 38](#).
- Install Liquid Line Sight Glass (indicates refrigerant dryness and if liquid in liquid line - do not use the sight glass to determine when refrigerant system is charged correctly), see [Figure 98 on page 38](#).
- Install pressure taps on the unit ventilator's liquid line and suction lines for subcooling and superheat measurements at the unit ventilator, see [Figure 98 on page 38](#).
- Install High Pressure Switch at condensing unit wired in condenser control system (protects compressor and refrigerant system from excessive pressures - condenser fan failure or overcharging), see [Figure 99 on page 39](#).
- Install Low Pressure Switch at condensing unit wired in the condenser control system (low refrigerant pressure switch protects the system under low refrigerant suction conditions), see [Figure 99 on page 39](#).
- Install Low Ambient Temperature Switch at condensing unit wired in the condenser control system (locks out mechanical cooling below 60°F - proper system operation and free economizer usage), see [Figure 99 on page 39](#).
- Incorporate Compressor Time Delay (5 minute) in condensing unit control system (reduces excessive compressor cycling), see [Figure 99 on page 39](#).
- Single phase compressors - consider hard start kits to overcome non-equalized pressure in refrigerant lines.

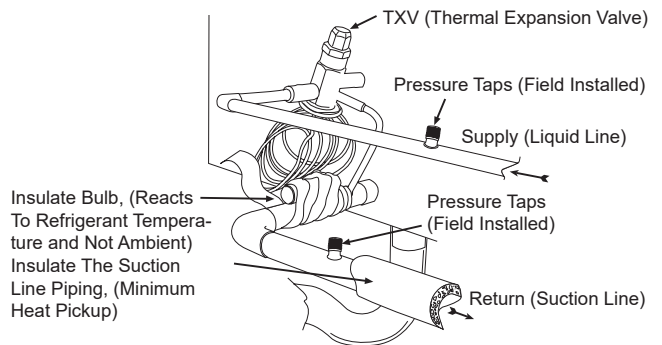
**Figure 96: Typical Piping and Wiring for Split System**



- Incorporate Low Refrigerant Temperature Sensor (T4) in condensing unit control system (T4 protects the system under low refrigerant suction conditions) see [Figure 99 on page 39](#).
- UV fans must continue to run upon Low Refrigerant Temperature trip of T4 (controls by others) or ICT (MicroTech) (evaporator air flow dissipates residual low coil surface temperatures - suction pressures raised, coil frosting reduced), see [Figure 99 on page 39](#).
- UV fans must continue to run for set time period during unoccupied mode after satisfaction of the space sensor (dissipates residual low evaporator coil surface temperatures - reducing coil frosting), see [Figure 99 on page 39](#).
- Lock the Face and Bypass Damper in the full face position during mechanical cooling (full air through evaporator coil reduces low refrigerant suction conditions, potential coil frosting)
- When Brazing bleed Nitrogen through piping (reduced oxides and blockage in piping/TXV)
- Use Heat Sink when brazing to prevent overheating the TXV valve body and bulb (avoid valve damage and erratic operation), see [Figure 94 on page 36](#).
- Verify the TXV bulb securely attached at 2 or 10 o'clock for 7/8" and smaller diameter suction line piping (proper suction gas sensing and reduced hunting) See [Figure 94 on page 36](#).

- Insulate the TXV bulb (reacts to refrigerant temperatures and not ambient), see [Figure 97](#).
- Insulate the suction line piping (minimum heat pickup), see [Figure 97](#).
- Evacuate and properly charge the refrigerant system, see [Figure 98 on page 38](#).
- Charge to subcooling at the condensing unit per the condensing unit manufacturer's instructions, typically 15°F to 16°F at the unit ventilator, subcooling at 95°F outdoor ambient (results in correct refrigerant distribution at the coil to prevent low suction temperatures)
- Adjust TXV for correct superheat to eliminate/minimize hunting, see [Figure 100 on page 40](#).
- Set superheat to 5°F to 7°F at the UV coil suction line when 95°F outdoor ambient (proper system superheat for optimum performance). Allow system to settle for 20 to 30 minutes to reach stable steady state conditions and then recheck/adjust superheat if necessary, see [Table 31 on page 39](#).
- Compensate both subcooling and superheat for actual outdoor ambient and indoor air temperatures
- In windy areas, add wind baffles to condensing unit or build a parapet (eliminate wind effect on condensing unit coil for proper TXV refrigerant flow at lower ambient)
- For lower ambient conditions install variable speed condenser fan head pressure control to maintain head pressures between 180psig and 280psig (for proper TXV refrigerant flow at lower ambient), see [Figure 99 on page 39](#).

**Figure 97: Insulate Bulb and Suction Line Piping**





## Checking System Charge

The system charge should be checked under design conditions [95°F outside air, 80°F/67°F (DB/WB) indoor air]. Refer to condensing unit manufacturer's guidelines.

Before adjusting refrigerant charge, verify that the unit ventilator is operating at normal design cfm. Nominal cfm is determined with a dry coil, and cfm will be reduced during air conditioning operation with a wet coil. Filters and coil must be clean and fan speed set at high temperature to obtain subcooling.

### NOTICE

Typical conditions - 95°F ambient, 45°F saturated suction temperature, 105°F saturated liquid temperature, 6-7°F superheat, 15°F subcooling.

## Determining Subcooling

To determine correct subcooling:

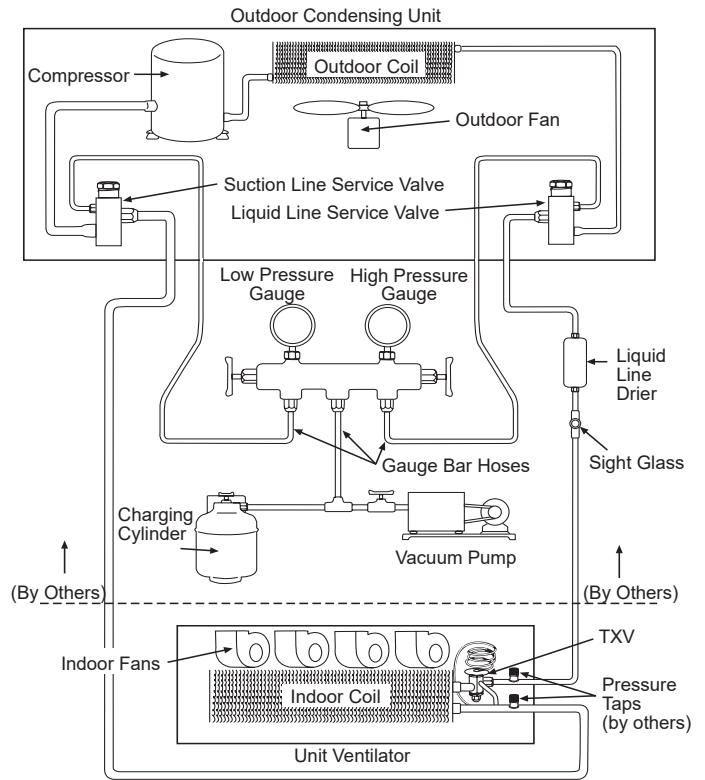
1. Measure outdoor ambient. It must be between 65°F and 105°F.
2. Measure liquid line temperature 6 inches from the TXV inlet.
3. Measure liquid line pressure near the TXV.
4. Determine saturated liquid temperature from saturated temperature pressure chart ([Table 30 on page 39](#)).
5. Subtract measured liquid line temperature from saturated liquid temperature to obtain subcooling.
6. Adjust charge per condensing unit manufacturer recommendation to obtain 15 - 16°F subcooling.

**Table 29: Dimensions, DX Tubing inches (mm)**

Models AVS, AVV, AVB, AVR	Suction Line O.D.	Liquid Line O.D.
750 cfm	3/4" (19mm)	1/4" (6mm)
1000 cfm	3/4" (19mm)	1/4" (6mm)
1250 cfm	7/8" (22mm)	3/8" (10mm)
1500 cfm	7/8" (22mm)	3/8" (10mm)

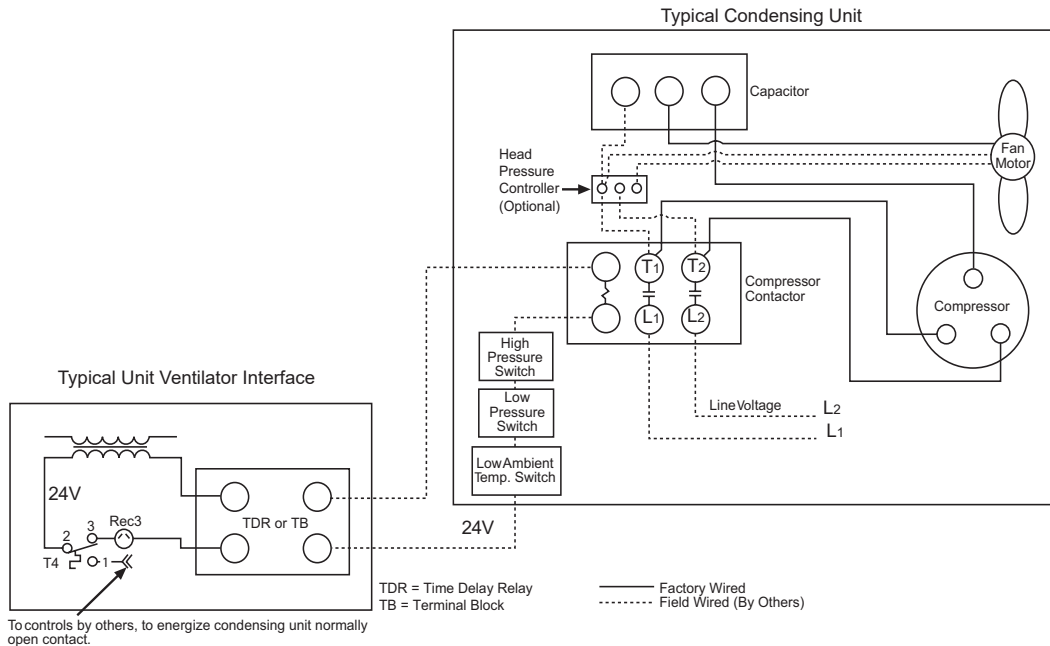
**Note:** [Table 29](#) piping dimensions are for systems with up to 30 ft. (9.14 m) vertical separation and up to 100 ft (30.47 m) horizontal separation from the outdoor condensing unit.

**Figure 98: Typical Split System Evacuation/Charging Setup**





**Figure 99: Typical Unit Ventilator/Condensing Unit Wiring Diagram**



**⚠ WARNING**

**Hazardous Voltage!** Disconnect all electric power including remote disconnects before servicing. Failure to disconnect power before servicing can cause severe personal injury or death.

### Determining System Superheat

After the subcooling has been determined, check system superheat.

1. Determine required superheat from superheat range, [Table 31](#).
2. Measure suction line temperature 6 inches from service valve.
3. Measure suction line pressure at service valve and determine saturated suction temperature from [Table 30](#).
4. Subtract saturated suction temperature from measured temperature to obtain superheat.
5. Refer to [Table 31](#) and adjust charge as required for correct superheat at ambient conditions.

**NOTICE**

Each time that charge is added or removed from the system, allow the system to run approximately 20 - 30 minutes before pressure and temperature readings are taken and superheat calculations made.

**NOTICE**

If system hunting occurs or subcooling is reduced, it may be necessary to adjust TXV to obtain correct superheat.

**Table 30: Saturated Temperature - Pressure Chart**

(°F)	R410A-PSIG	(°F)	R410A-PSIG	(°F)	R410A-PSIG
32	101.1	44	127.7	80	235.8
33	103.2	45	130.2	85	254.7
34	105.2	46	132.6	90	274.5
35	107.4	47	135.1	95	295.5
36	109.5	48	137.5	100	317.6
37	111.7	49	140.1	105	340.9
38	113.9	50	142.6	110	365.4
39	116.2	55	147.0	115	391.2
40	118.4	60	170.1	120	418.3
41	120.7	65	185.2	125	446.9
42	123.0	70	201.1	130	476.8
43	125.4	75	218.0	140	541.4

**Table 31: Superheat Range**

Outdoor Ambient	Indoor Coil Air Inlet Temp. DB/WB (50% RH)		
	75/63	80/67	85/71
105	*	*	8-10
100	*	3-5	9-11
95	*	5-7	11-13
90	*	9-11	13-15
85	5-7	10-12	15-17
80	8-10	12-14	18-20
75	10-12	15-17	21-23
70	13-15	19-21	24-26
65	15-17	21-23	26-28

**NOTICE**

Typical conditions - 95°F ambient, 45°F saturated suction temperature, 105°F saturated liquid temperature, 6-7°F superheat, 15°F subcooling.

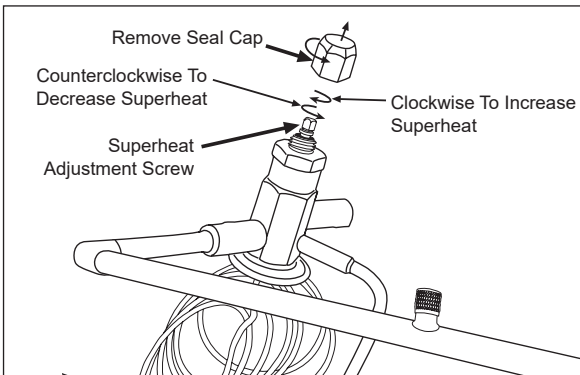
**Superheat Adjustment**

1. Remove the seal cap from thermal expansion valve (see [Figure 100](#)).
2. Turn the adjustment screw clockwise to increase superheat and counterclockwise to decrease superheat ([Figure 100](#)). One complete 360° turn changes the superheat approximately 3-4°F, regardless of the refrigerant type. As much as 30 minutes may be required for the system to stabilize after the adjustment is made.
3. Replace and hand-tighten seal cap.

**CAUTION**

Do not force adjustment stem of TXV. When adjusting superheat setting, there are a maximum of 10 turns on the stem. Turning adjustment stem after reaching stop will damage valve.

**Figure 100: Superheat Adjustment of TXV**



**Making Control Connections**

**MicroTech Unit Mounted DDC Control Components – Models AVS, AVV, and AVR**

**Note:** Refer to [Figure 102 on page 42](#).

- 1 **MicroTech Unit Ventilator Controller (UVC):** (Located Beneath the Local User Interface Panel). Factory mounted and run tested, microprocessor-based DDC control device capable of complete Standalone unit control, Client/Server control or incorporated into a building-wide network using an optional plug-in communication module. The UVC contains a microprocessor that is preprogrammed with the application code required to operate the unit. The

UVC supports up to 16 analog inputs, 8 binary inputs, 4 analog outputs, 2 PWM outputs, and 14 binary outputs. Client/Server units have the controller factory configured and installed for a local peer-to-peer network between these units (network wiring between these units needs to be field installed). Optional network communication is provided via plug-in communication modules that connect directly to the UVC.

- 2 **Communication Module (optional):** Plug-in network communication module that is attached to the UVC via a 8-pin header and 4 locking standoffs. Available communication modules:
  - **Building Automation and Control Network (BACnet®) Client Server/Token Passing (MS/TP) –** Allows the UVC to inter-operate with systems that use the BACnet (MS/TP) protocol with a conformance level of 3. Meets the requirements of ANSI/ASHRAE 135-2008 standard for BACnet systems
  - **LONWORKS® compliant Space Comfort Controller (SCC) –** Supports the LONWORKS SCC profile number 8500\_10
- 3 **Local User Interface (LUI) (optional):** (see [Figure 101 on page 42](#)) The LUI provides a unit mounted interface which indicates the current unit operating state and can be used to adjust the unit ventilator operating parameters (operating mode, temperature set points, fan speed and occupancy mode). The LUI features a 4 x 20 OLED digit display, 6 keys, and 2 individual LED indicators. In addition to the operating mode states and fan functions, the touch pad will digitally display:
  - The room set point temperature
  - The current room temperature
  - Any fault code for quick diagnostics at the unit
- 4 **External Signal Connection Plugs:** Three (3) multi-pin plugs are factory provided and pre-wired with short wire whips that are capped (they must remain capped if not used). Provided for field wiring of:
  - **Remote Wall Mounted Temperature Sensor (optional accessory)**
  - **External Input Signals (by others) –** Unoccupied, remote shutdown, ventilation lockout, dew point/humidity (night time operation), or exhaust interlock signals
  - **External Output Options (by others) –** Fault indication signal, exhaust fan on/off or auxiliary heat signal
- 5 **Electric Connection Box:** Contains the motor speed transformer. Refer to the unit wiring diagram for specifics.

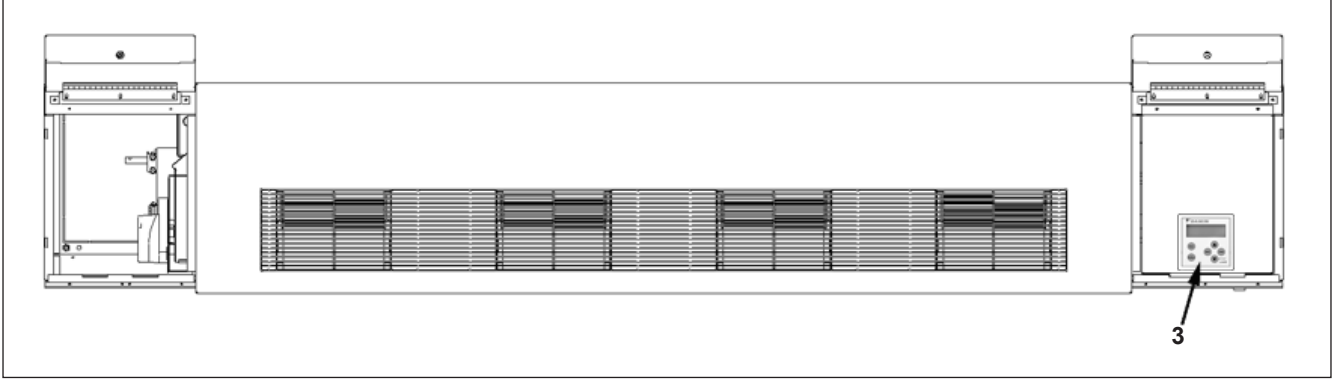
- 6 Unit Main Power “On-Off” Switch: (SW1)**  
Disconnects the main power to the unit for servicing or when the unit is to be shut down for an extended period of time.
- 7 Fuse(s):** Fan motor and controls have the hot line(s) protected by factory installed cartridge type fuse(s).
- 8 Control Transformer:** 75 VA 24-volt NEC Class 2 transformer for 24 volt power supply. (Located behind the motor transformer.)
- 9 Outdoor Air/Return Air Damper Actuator: (A1)**  
Proportional, direct-coupled actuator that spring returns the outdoor air damper to the closed position upon a loss of power.
- 10 Face and Bypass Damper Actuator: (A2)**  
Proportional, direct-coupled control actuator that is non-spring returned (Model AVS only).
- 11 Hydronic Coil Low Air Temperature Limit (T6 freezestat):** Factory installed on all units with hydronic (water) coils. The T6 freezestat cuts out at 38°F (+/- 2°F) and automatically resets at 45°F (+/- 2°F).
- 12 Low Refrigerant Temperature Sensor (ICT):** The ICT sensor is provided on all units with a direct expansion (DX) cooling coil. It is located on the right hand side of the coil “u-bend”.

## NOTICE

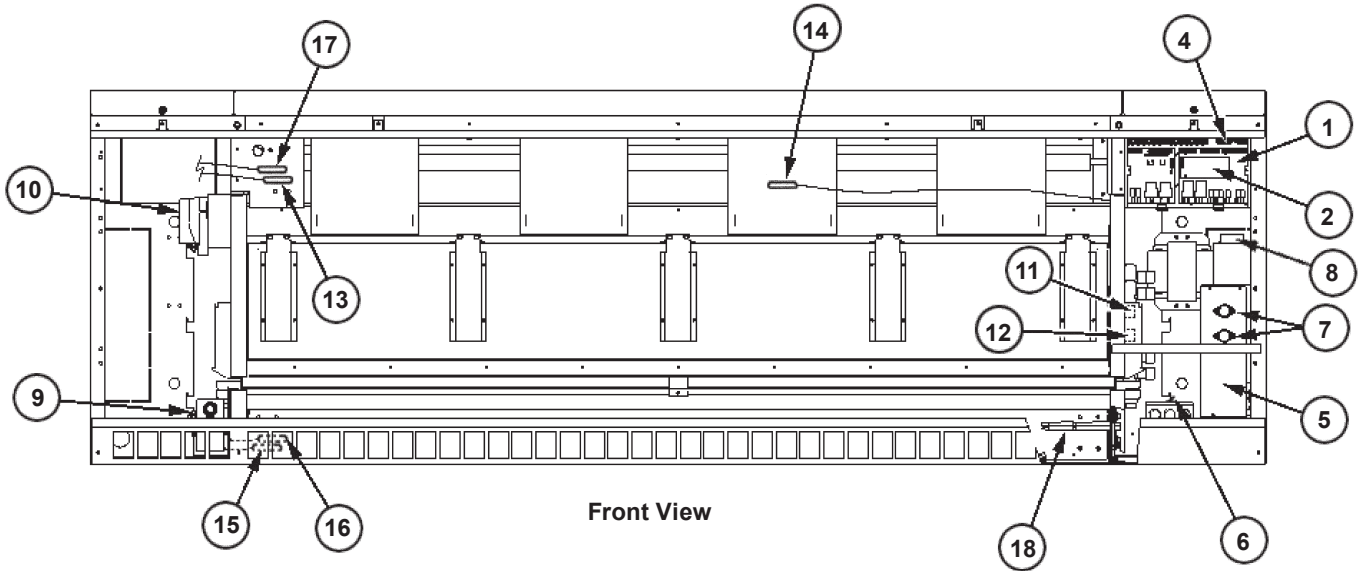
Not all external signal options can be used simultaneously and may not be available on all software models.

- 13 Room Temperature Sensor (RAT):** The unit mounted sensor is located in the sampling chamber (front, center section) where room air is continuously drawn through for prompt response to temperature changes in the room. A Remote Wall Mounted Temperature Sensor is also available for remote room temperature sensing, (optional accessory).
- 14 Discharge Air Temperature Sensor (DAT):** The sensor is located on the second fan from the right to sense discharge air temperatures.
- 15 Outdoor Air Temperature Sensor (OAT):** The sensor is located in the outdoor air section of the unit before the outdoor air damper. With network applications, the unit mounted sensor can be overridden by a remote sensor through the network.
- 16 Outdoor Air Humidity Sensor (OH) (optional):**  
Unit mounted humidity sensor for units using Expanded outdoor enthalpy economizer or Leading Edge indoor/outdoor, true enthalpy comparison economizer. The sensor is located in the outdoor air section of the unit before the outdoor air damper. With network applications, the unit mounted sensor can be overridden by a remote sensor through the network.
- 17 Room Humidity Sensor (IH) (optional):** - Unit mounted humidity sensor for units capable of passive or active dehumidification or with units using Leading Edge indoor/outdoor, true enthalpy comparison economizer. The sensor is located in the sampling chamber (front, center panel) where room air is continuously drawn through for fast response to humidity changes in the room. With network applications, the unit mounted sensor can be overridden by a remote sensor through the network.
- 18 CO<sub>2</sub> Sensor (CO2) (optional):** Unit mounted, single beam absorption infrared gas sensor with a sensing range of 0 – 2000 ppm and voltage output of 0 to 10 VDC (100 ohm output impedance). The Pitot Tube sensing device is located in the unit ventilator’s return air stream. The optional CO<sub>2</sub> sensor is used with the UVC’s Demand Control Ventilation feature to vary the amount of outside air based on actual room occupancy. With network applications, the unit mounted sensor can be overridden by a remote sensor through the network.
- 19 Control Valve(s) (not shown):** Optional accessory valve(s) may be either 2 position “End of Cycle” (AVS and AVB models) or modulating (AVV and AVR models), to control the quantity of water through the coil. Available in 2-way or 3-way configurations. Spring return actuators are required for all hot water and steam heating valves. All heating valves are Normally Open (NO) and all cooling valves Normally Closed (NC). (See piping/valve section.)
- 20 Water In Temperature Sensor (OCT) (not shown):**  
The water in temperature sensor is factory wired on 2-pipe CW/HW units only. The sensor must be field installed and insulated (by others) on the supply connection of the hydronic coil. The sensor must be located on the supply connection where there is continuous water flow. It is located on the same side as the coil connections. The sensor measures the entering water temperature to determine if the temperature is acceptable for either heating or cooling based on the unit’s operating state. (See piping section.)

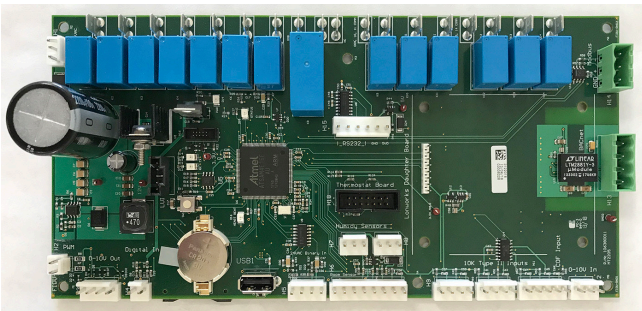
**Figure 101: AV Top View**



**Figure 102: MicroTech Sensor and Component Locations**



**Figure 103: MicroTech Control Board**



**Note:** If Installing Communication Module, refer to the installation instructions specific to that Communication Module.

## Economizer Control Capabilities

**Basic** – Compares the inside and outside air temperatures using item 13 (Room Temperature Sensor) and item 15 (Outdoor Air Temperature Sensor) to determine if outdoor air can be used for “free”, economizer cooling operation.

**Expanded** – Compares the inside and outside air temperatures using item 13 (Room Temperature Sensor) and item 15 (Outdoor Air Temperature Sensor) and calculates the enthalpy of the outside air relative humidity using item 16 (Outdoor Air Humidity Sensor) to determine if outdoor air can be used for “free”, economizer cooling operation.

**Leading Edge** – True enthalpy comparison economizer that compares the inside and outside air temperatures using item 13 (Room Temperature Sensor) and item 15 (Outdoor Air Temperature Sensor) and compares the enthalpy of the inside and outside air relative humidity using item 16 (Outdoor Air Humidity Sensor) and item 17 (Room Humidity Sensor) to determine if outdoor air can be used for “free”, economizer cooling operation.

## Economizer for Reheat

**Basic** – Uses items 13 (Room Temperature sensor, item 15 (Outdoor Air Temperature Sensor) and item 17 (Room Humidity Sensor) for active dehumidification (reheat) or to determine if outdoor air can be used for “free”, economizer cooling operation.

**Leading Edge** – Uses items 13 (Room Temperature Sensor), item 15 (Outdoor Air Temperature Sensor), item 16 (Outdoor Air Humidity Sensor) and item 17 (Room Humidity Sensor) for active dehumidification (reheat) or to determine if outdoor air can be used for “free”, economizer cooling operation.

## Local User Interface (LUI)

Figure 104: Local user interface (LUI)



The optional built-in LUI touch pad with digital OLED display is located in the right hand compartment below the top right access door. The 4 x 20 OLED display will provide a variety of information including:

## Operating mode states

- **Fan** functions
- **Room** set point temperature
- **Current** room temperature
- **Fault** codes for quick diagnostics at the unit

The LUI has a built in menu structure (Password protected) with 4 keys and 2 individual LED indicators to adjust the unit ventilator operating parameters shown in the following.

## Operating Mode States (4)

- **Heat** - Heating and economizer operation only
- **Cool** – Cooling and economizer operation only
- **Fan Only** – Fan operation only
- **Auto** – Unit automatically switches between heating, cooling and economizer operation to satisfy the room load conditions. The current unit state is also displayed.

## Fan States (4)

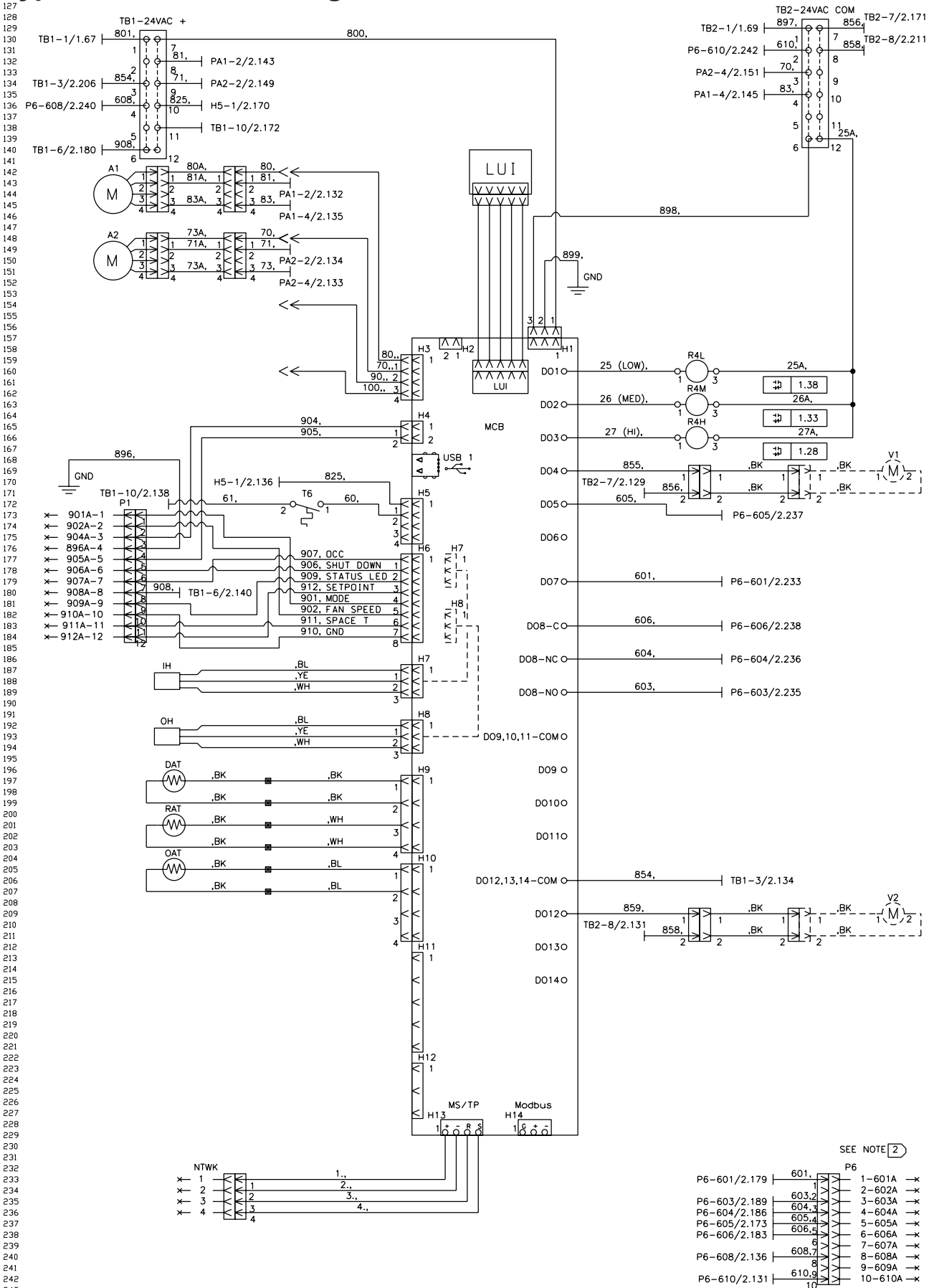
- **High** (constant speed)
- **Medium** (constant speed)
- **Low** (constant speed)
- **Auto** (part load, variable air) – Varies the fan speed automatically to meet the room load conditions whether the unit is in heating, cooling or economizer mode. The current fan speed is also displayed. During low load or normal operation (about 60% of the time) the fans will operate at low speed. When the load increases to an intermediate demand the fans automatically shift to medium speed. At near design or design load conditions, the fans will operate on high speed. A 10-minute delay between speed changes is incorporated to minimize the awareness of these changes. The outdoor air damper will index based on the fan speed to maintain the required minimum cfm (cubic feet per minute) of ventilation air.

## Occupancy Modes (4)

- **Occupied** – Normal, daytime operation where the unit maintains the room set point.
- **Unoccupied** – Night set back operating mode in which the unit responds to a new room set point and cycles to maintain the condition. The fan comes on when heating or cooling is needed and runs until the load is satisfied. The outside air damper is closed during this mode. With direct expansion (DX) cooling units, when a cooling load is satisfied by the refrigerant system, the compressor is de-energized and the Unit Ventilator indoor fan continues to run for a fixed period of time to remove possible frost buildup on the evaporator coil.
- **Stand By Mode** – The unit ventilator maintains the stand by mode set point temperature with the outside air damper closed. The fan runs continuously unless it is configured to cycle in response to the room load.



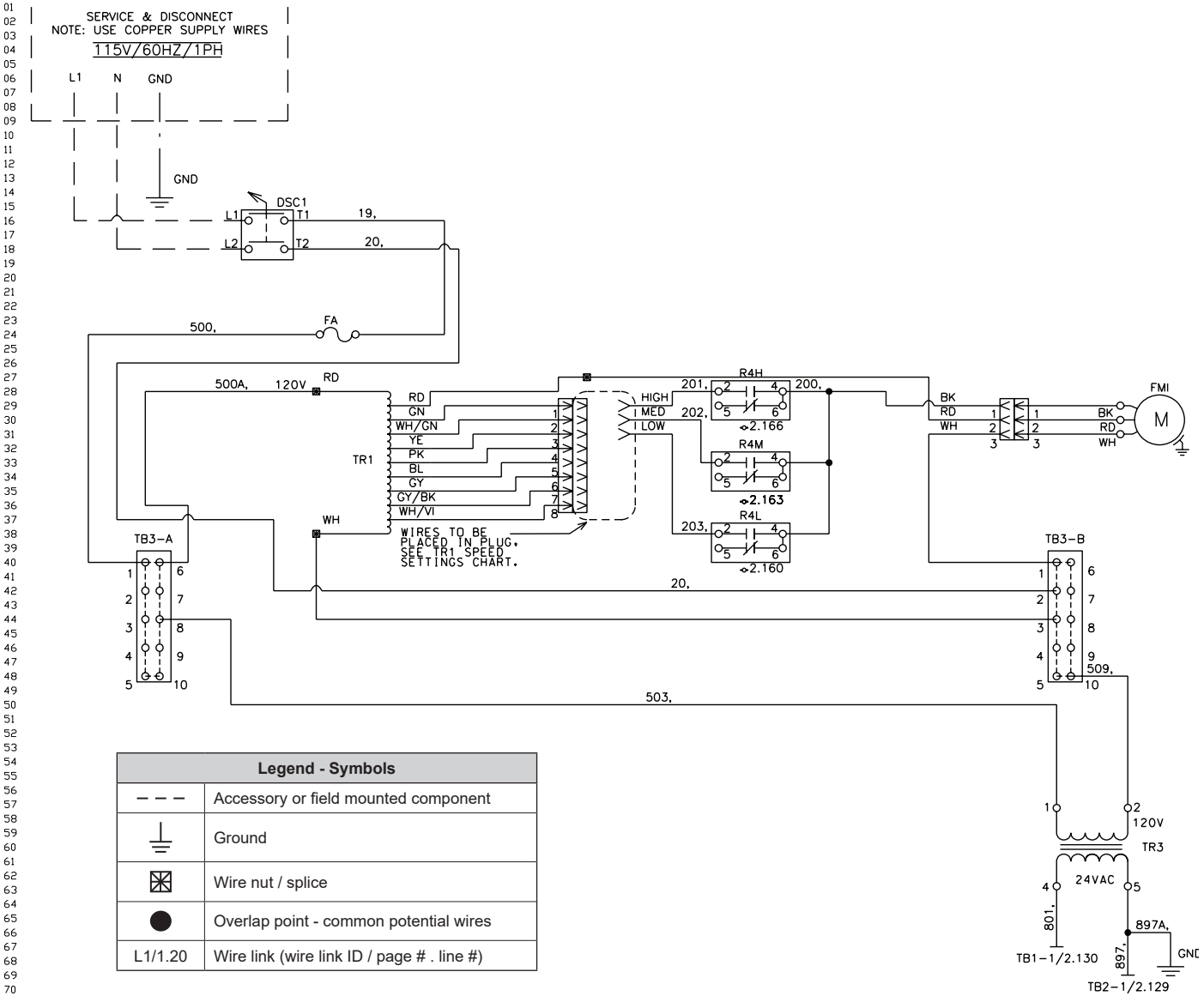
# Typical MicroTech Wiring – 115Volt / 60Hz / 1 Phase



Note: See page 45 for typical MicroTech service and disconnect wiring and wiring schematic legend.



**Typical MicroTech Wiring Diagram – Service and Disconnect, 115Volt / 60Hz / 1 Phase**



**Table 32: Legend for Typical MicroTech Wiring**

Symbol	Description	Symbol	Description	Symbol	Description
A1	Actuator- Outdoor Air	OH1	Thermostat - Overheat	MCB	Main Control Board
A2	Actuator- Face & Bypass	OH2	Thermostat - Overheat	IH	Sensor - Indoor Humidity
C1	Compressor Contactor	OHM	E.H. Man Reset - Overheat Stat	OH	Sensor - Outdoor Humidity
CAP1	Capacitor Run	PL1	LED Occupancy / Fault Status	CO2	Sensor - Indoor Air CO2
CEH1-3	Electric Heat Contactor	R1-R3	Relay Electric Heat (Backup)	DCS	Switch - Unit Power
DF	Dead Front Switch	R10-R12	Relay – Electric Heat	TB1	Terminal Block - 24VAC+
F1A/F1B	Fuse - Compressor	R4H	Relay – Fan High Speed	TB2	Terminal Block – 24VAC Gnd
F2A/F3C	Fuse - Electric Heat	R4M	Relay– Fan Medium Speed	TB3	(A, B) Terminal Block – Main Power
FA/FB	Fuse– Control, Load	R4L	Relay– Fan Low Speed	TBE	Terminal Block - Electric Heat
FC/FD	Fuse– Control, Transformer	R32	Relay - Drain Pan Heater	TR1	Transformer - Motor Speed
HP	High Pressure Switch	R28	Relay - Outdoor Motor Air	TR3	Transformer - 208 / 230V-24V, 75VA
EH1-6	Heater - Electric	RV	Reversing Valve	TR4	Transformer - 460V–230V
EH10	Heater - Outdoor Drain Pan	RAT	Sensor - Room Air Temperature	TR5	Transformer - 208 / 230V-24V
FMI	Motor - Room Fan	DAT	Sensor - Discharge Air Temperature	V1	Valve - Heat EOC (Accessory)
CP1	Motor Compressor 2-Stage	OAT	Sensor - Outdoor Air Temperature	V2	Valve - Cool EOC (Accessory)
FMO	Motor Outdoor Air	ICT	Sensor - Indoor DX Coil Temperature	VH	Valve - Heat (Accessory)
NTWK	Network Connection	OCT	Sensor - Outdoor DX Coil Temperature	VC	Valve - Cool (Accessory)

- Notes:**
- All electrical installation must be in accordance with national and local electrical codes and job wiring schematic.
  - External wiring options - see IM for the different configured options, wiring to be minimum 18 gauge, 90°C.
  - EC motors are factory programmed for specified air flow. Contact Daikin Applied for replacement.
  - Cap extra wire. Switch wire 42A to red wire for 208V operation.
  - Switch wire 509 to terminal 2 for 208V operation.
  - Devices in legend may or may not be on unit.

# MicroTech Unit Electrical Connections

## **⚠ DANGER**

Do not force adjustment stem of TXV. When adjusting superheat To avoid electrical shock, personal injury or death, be sure that field wiring complies with local and national fire, safety, and electrical codes, and voltage to the system is within the limits shown in the job-specific drawings and unit electrical data plate(s)

## **⚠ WARNING**

Power supply to unit must be disconnected before making field connections. To avoid electrical shock, personal injury or death, be sure to rigorously adhere to field wiring procedures regarding proper lockout and tagout of components.

See [Table 33](#), [Figure 105](#), [Figure 106](#) and the job-specific electrical drawings before proceeding with field power and control wiring. See also the wiring diagram provided on the unit ventilator right front access panel.

Unit ventilators equipped with an optional electric heating coil have electric heating coil power connections at right end only.

## Procedure

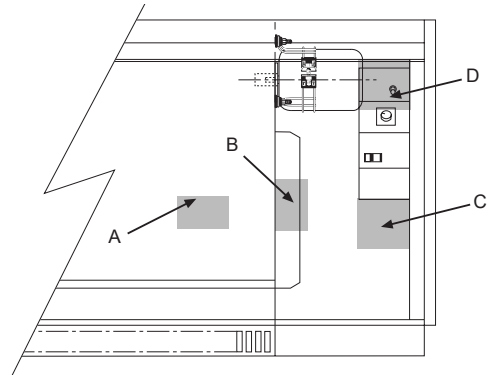
1. Provide power supply to right end compartment to match unit nameplate.

## **⚠ CAUTION**

Use copper conductors only. Use of aluminum conductors may result in equipment failure and overheating hazards. All wiring in right hand compartment must be class 1.

2. Wire leads provided from unit ventilator electric connection box to load side of unit power switch (switch provided by Daikin Applied). The junction box has 1"(25mm) and 2"(51mm) knockouts, located 10-1/2"(267mm) from right end of unit.
3. Provide ground wire from grounding screw in switch junction box to switch ground terminal.
4. Wire field power supply to line side of unit power switch. Wire ground conductor to switch ground terminal.
5. Mount unit power switch in switch junction box and install switch cover plate (provided).
6. On units with electric heat, the 2 pole unit power switch is replaced by a 3 pole switch, and is mounted as shown on [Figure 105](#). (A) shows switch location for valve control units and (B), (C) and (D) show location for Face & Bypass control units. (B) is for 208, 230 and 265 volt units. (C) shows location for 460 volt units.

**Figure 105: Electric Heat Unit Power Switch Locations**



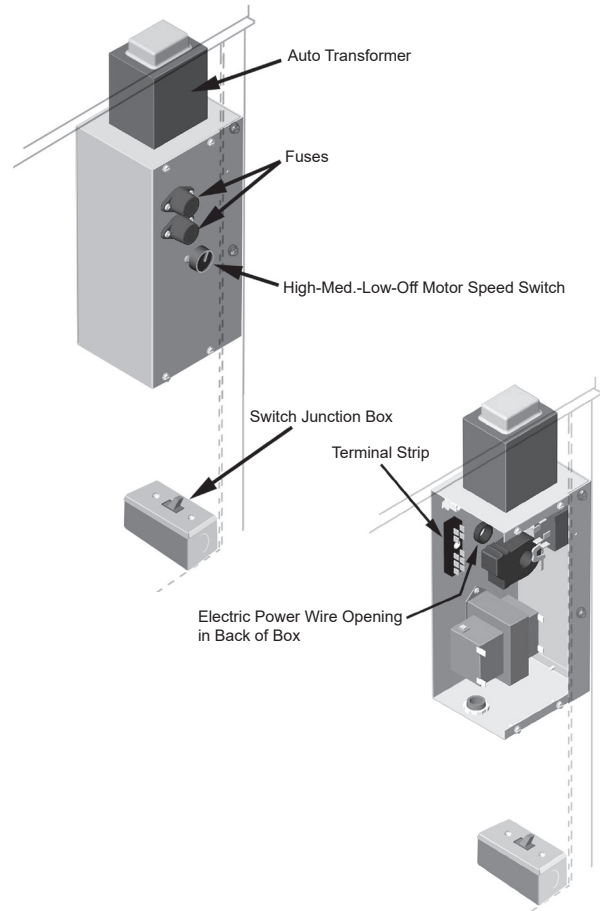
**Table 33: Floor AV Electrical Data/Motor Data and Unit Amp without Electric Heat**

Unit Series	CFM (Nom.)	L/s	Motor HP	Watts	Unit Current #			
					115V	208V	230V	265V
S07	750	354	1/4	164	1.8	1.0	0.9	0.8
S10	1000	472	1/4	244	3.1	1.7	1.5	1.3
S13	1250	590	1/4	306	3.5	1.9	1.8	1.5
S15	1500	708	1/4	334	3.7	2.0	1.8	1.6

# Amps at unit voltage, 60 Hz, single phase

**Note:** See [Electric Heating - PSC Motor on page 64, Table 38 and Table 39](#).

**Figure 106: Electric Connection Box and Junction Box Located in Right End Compartment**



## MicroTech Wall Mounted Sensor

### WARNING

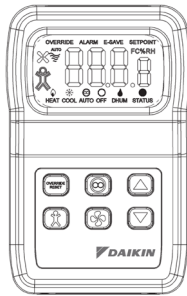
Rigorously adhere to field wiring procedures regarding proper lockout and tagout of components.

### WARNING

- To avoid electrical shock, personal injury or death:
1. Installer must be qualified, experienced technician.
  2. Disconnect power supply before installation to prevent electrical shock and damage to equipment.
  3. Make all connections in accordance with electrical wiring diagrams, and in compliance with national and local codes. Use copper conductors only.
  4. Do not exceed ratings of the device. This is a low voltage device: Never apply more than 12VAC/VDC to any lead or damage will result.
  5. Avoid locations where excessive moisture, corrosive fumes, or vibrations are present.

**Note:** Avoid placing wall sensor near drafty areas such as doors or windows. Avoid external walls, or dead spots near exposed columns. Avoid direct sunlight on wall sensor.

**Figure 107: Wall Mounted Temperature Sensor**



## When Using A Remote Temperature Sensor

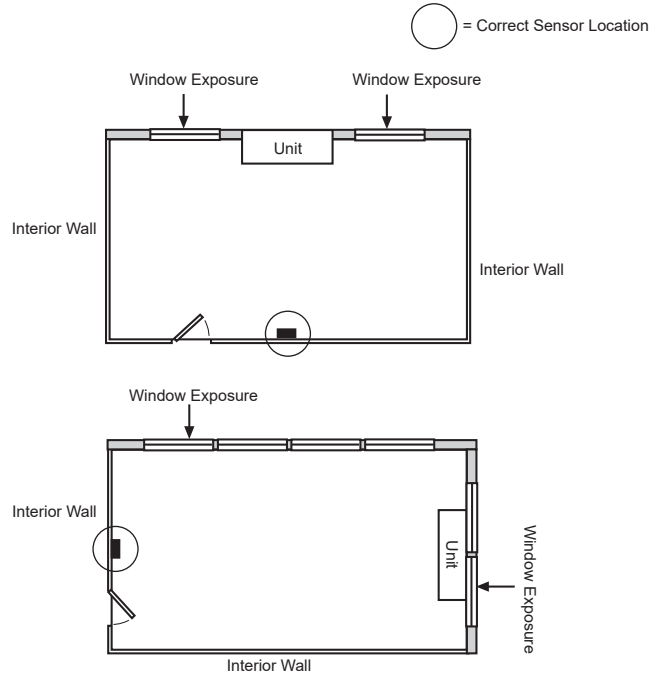
If a decision is made to use a Wall Mounted Temperature Sensor instead of the unit mounted room air sensor then placement of the Remote Wall Mounted Temperature Sensor is critical for proper room temperature sensing (see [Figure 108](#) and [Figure 109](#)). The UVC is capable of using one of four remote wall mounted temperature sensors. It is recommended that additional wires be pulled to compensate for potential wire breakage or future options.

- 6-Button Digital Adjustable Sensor (PN 910247458)  
8 total wires (power and ground wires should be bundled separately)
- 4-Button Digital Adjustable Sensor (PN 910247448)  
6-wires (power and ground wires should be bundled separately)
- The Basic Sensor with setpoint adjustment (PN 910247453) 4-wires
- The Basic Sensor (PN 910247450) 3-wires

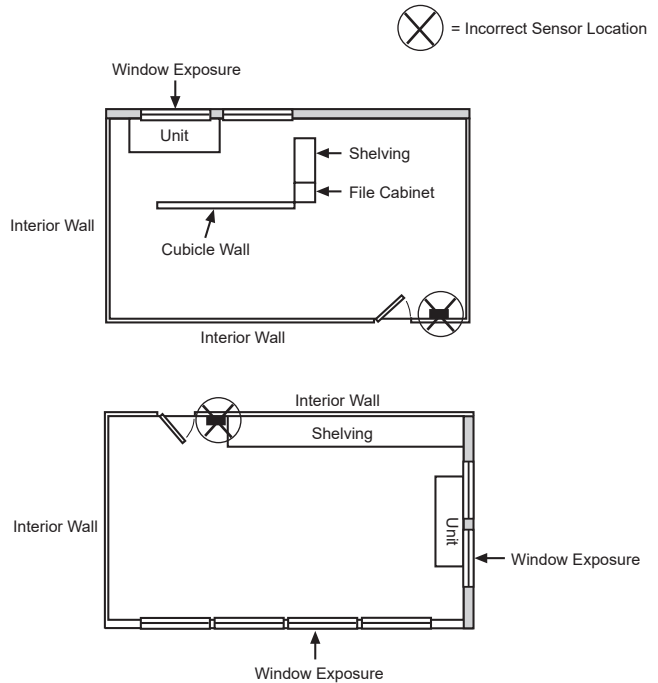
### NOTICE

For sensor terminal wiring details see the installation manual specific to the sensor being used.

**Figure 108: Correct Wall Sensor Locations**



**Figure 109: Incorrect Unit and Wall Sensor Locations**



**Table 34: Max Sensor Wire Length and Gauge**

Maximum sensor wire length for less than 1°F error	
Gauge	Length
14 AWG	800 ft. (244 m)
16 AWG	500 ft. (152 m)
18 AWG	310 ft. (94 m)
20 AWG	200 ft. (61 m)
22 AWG	125 ft. (38 m)

**⚠ CAUTION**

Static sensitive components. A static discharge while handling electronic circuit boards can cause damage to the components. Discharge any static electrical charge by touching the bare metal inside the main control panel before performing any service work. Never unplug any cables, circuit board terminal blocks, relay modules, or power plugs while power is applied to the panel.

## Typical Connections For Temperature Sensor Applications

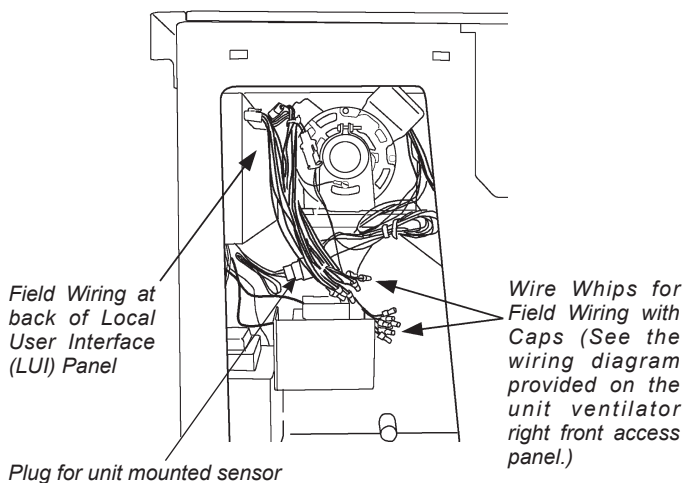
The low voltage field wiring connections have all been centrally located within the unit ventilator and are easily accessible.

To simplify field connections, multi-pin plugs are factory provided and pre-wired with short wire whips (Figure 110). Each of the wires in these wire whips is capped and should remain capped if not used. See Table 35 on page 50 for wiring the remote mounted temperature sensor to the unit control wiring.

All low voltage field wiring connections must be run in shielded cable with the shield drain wires connected as shown in the field wiring diagrams.

For sensor terminal wiring details see the installation manual specific to the sensor being used.

**Figure 110: Model AV - Field Wiring Whips with Caps Viewed from Right End Compartment**



## Sensor Functions

- Display sensor to show room Temperature, fan speed (AUTO/HIGH/MEDIUM/LOW), system mode (HEAT/COOL AUTO/OFF), ALARM, Override and occupancy.

## Mounting

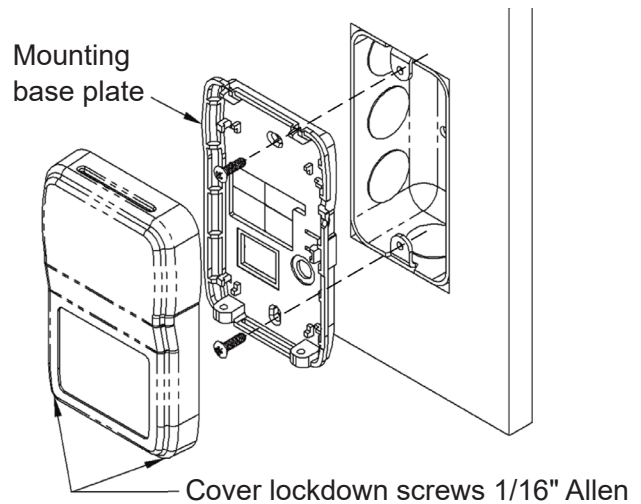
### Location

Avoid mounting on outside walls or in direct sunlight.

### Junction Box, (J-Box)

1. Pull the wire through the wall and out of the junction box, leaving about six inches free.
2. Pull the wire through the hole in the base plate.
3. Secure the back plate to the box using the #6-32 × 1/2 inch mounting screws provided.
4. Screw the plate firmly to the wall so the foam plate backing is compressed about 50%.
5. Terminate the unit according to the guidelines in the Termination section.
6. Attach Cover by latching it to the top of the base, rotating it down and snapping into place.
7. Secure the cover by backing out the lock-down screws using a 1/16" Allen wrench until it is flush with the bottom of the cover.

**Figure 111: Junction box mounting (hardware is provided for both junction box and drywall installation.)**



## Drywall Mounting

1. Place the base plate against the wall where you want to mount the sensor.
2. Mark out the two mounting holes where the unit will be attached to the wall. Drill a 3/16" hole in the center of each mounting hole and insert a drywall anchor into the holes.
3. Drill one 1/2" hole in the middle of the marked wiring through hole area.
4. Pull the wire through the wall and out the 1/2" hole, leaving about six inches free.
5. Pull the wire through the hole in the base plate.

6. Secure the base to the drywall anchors using the #6 × 1" mounting screws provided.
7. Screw the plate firmly to the wall so the foam plate backing is compressed about 50%.
8. Terminate the unit according to the guidelines in the Termination section.
9. Attach cover by latching it to the top of the base, rotating it down and snapping it into place.
10. Secure the cover by backing out the lock-down screws using a 1/16" Allen wrench until it is flush with the sides of the cover

**Note:** *In any wall-mount application, the wall temperature and the temperature of the air within the wall cavity can cause erroneous readings.*

*The mixing of room air and air from within the wall cavity can lead to condensation, erroneous readings and sensor failure. To prevent these conditions, Daikin Applied recommends sealing the conduit leading to the junction box with fiberglass.*

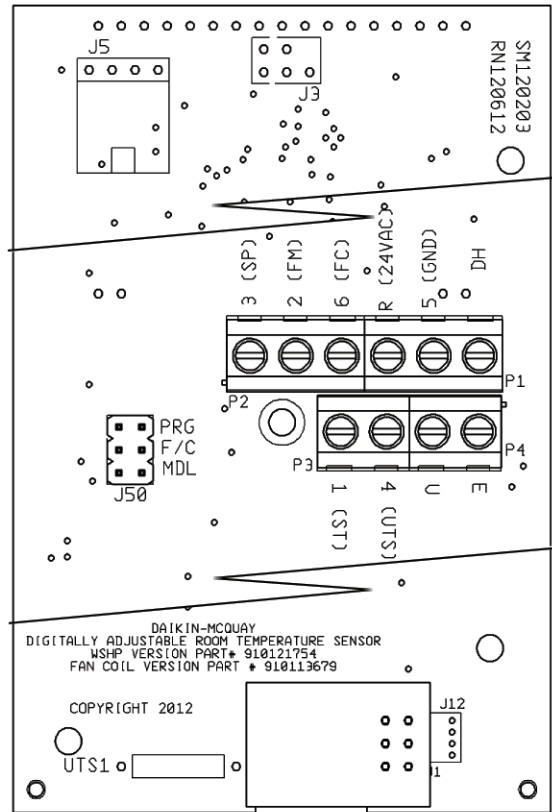
**Maintenance**

Wipe the display as needed with a damp water only cotton cloth. Do not use any type of cleaner as it may damage the buttons or scratch the display. Do not paint.

**Terminations**

Daikin Applied recommends using shielded 22AWG for all connections and a separate twisted pair for the power wire connections. The shield should be earth grounded only at the power source. Larger gauge wire may be required for runs greater than 250'.

**Figure 112: Sensor Circuit Board**



**⚠ CAUTION**

The AC power wiring at terminals [R] & [5] should be run in a separate twisted shielded pair to avoid fluctuating and inaccurate signal levels induced into the other sensor signal wires. This sensor AC power can be run in the same conduit with the sensor signal wire as long as it's run in twisted, shielded pair and terminated properly.

All wiring must comply with the National Electric Code (NEC) and local codes. Do NOT run any of this device's wiring in the same conduit as other AC power wiring. Tests show that fluctuating and inaccurate signal levels are possible when AC power wiring is present in the same conduit as the signal lines. If you are experiencing any of these difficulties, please contact your Daikin Applied representative.

**Table 35: Unit Ventilator MicroTech Board to Room Temperature Sensor Wiring**

MicroTech Base Board									
Terminal Block Label	TB1	H6-1	H6-2	H6-3	H6-4	H6-5	H6-6	H6-7	H6-8
Sensor 910247458	●	●	○	●	●	●	●	●	●
Sensor 910247448	●	●	○	●	●	○	○	●	●
Sensor 910247453	○	○	○	●	●	○	○	●	●
Sensor 910247450	○	○	○	●	○	○	○	●	●
Description	24VAC	Occupancy	Shutdown (Not Used)	Status LED	Setpoint	Unit Mode	Fan Speed	10K RTD	Ground
Wire	908	907	906	909	912	901	902	911	910

Typical Wiring

Terminal Label	R	U	1 (ST)	3 (SP)	2 (FM)	6 (FC)	4 (UTS)	5 (GND)
Description	24VAC	Unoccupied	Unit Status Output	Setpoint Adjust	Unit Mode	Fan Speed	Room Temp Sensor & Tenant Override	Ground

Room Temperature Sensor

**Terminal Designations**

● = Active Terminal    ○ = Not Used



# Making Control Connections

## Digital Ready™ – Face & Bypass Control Components Model AVS

Digital Ready is a factory installed pre-wired package of selected Direct Digital Control (DDC) components. It facilitates the field hook up of a DDC Unit Ventilator Controller (UVC) that is compatible with these factory installed, pre-wired components, and capable of providing the standard ASHRAE II cycle.



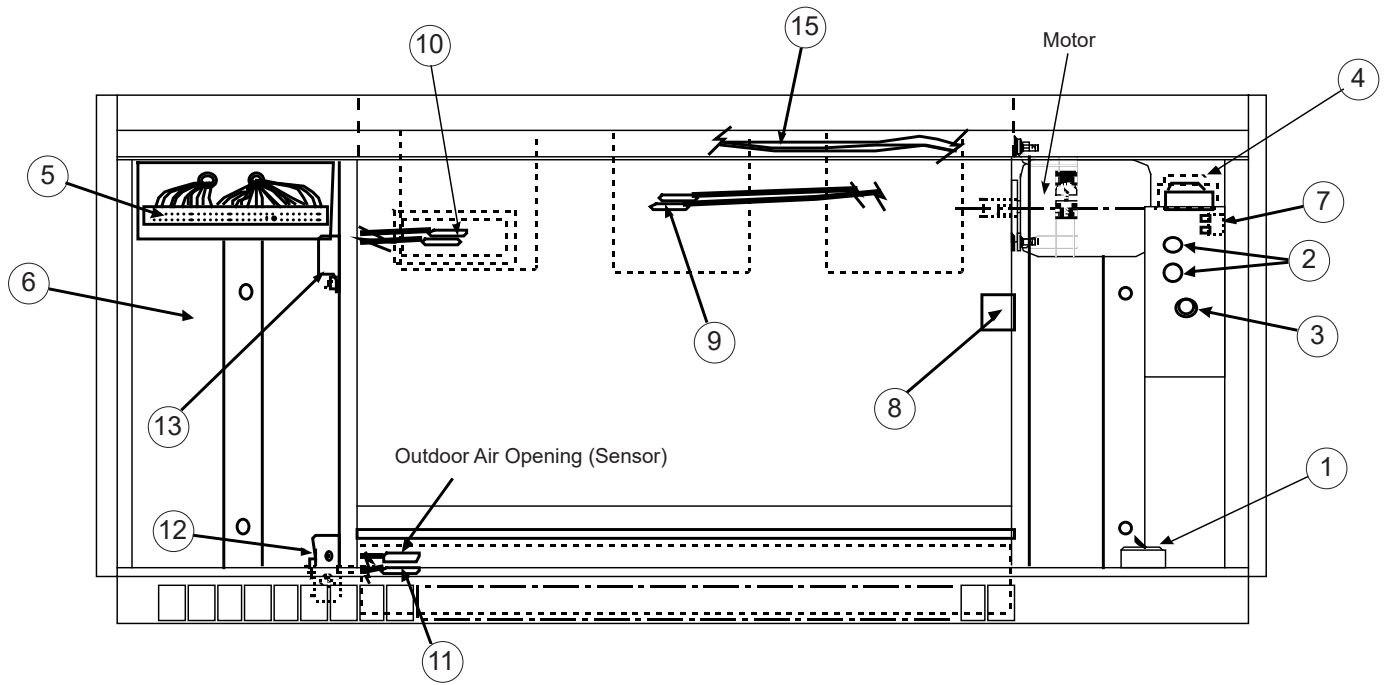
### CAUTION

It is the responsibility of the Automatic Temperature Control supplier to ensure the controls operate correctly and protect the unit.

Digital Ready consists of the following components which are factory wired and powered:

1. **Unit Main Power “On-Off” switch:** disconnects main power to the unit for service. Non-fused power interrupt switch
  2. **Fuse(s):** fan motor, auto transformer and control transformer have the hot line(s) protected by factory installed cartridge type fuse(s).
  3. **Three (3) speed HIGH-MEDIUM-LOW-OFF motor fan speed switch (SW2).**
  4. **75 VA 24-volt NEC Class 2 transformer:** for 24-volt power supply.
  5. **Three 10-pole Europa type 16 awg terminal strips:** rated for 10 amps at 300 volts with nickel plated connectors and zinc plated clamping screws (TB1, TB2, TB3).
  6. Space available in left end compartment, approximately 8" x 21" (203mm x 533mm) for UVC mounting (by others).
- Wired to the Terminal Strips:**
- 7 Interface with the fan motor start/stop relay, (R4) in electric connection box.
  8. **Low Air Temperature Limit (T6 - Freezestat):** factory installed, cuts out below 38°F±2 °F and automatically resets above 45°F±2 °F. Responds when any 15% of the capillary length senses these temperatures. Wired so that upon T6 cut out, the outside air damper (A1) closes, the hot water valve opens and the 24 volt power supply to the terminal strip (T6 Sig) is interrupted.
  9. **Discharge Air Temperature Sensors (S2):** 10 K ohm NTC (Negative Temperature Coefficient) and 1 K ohm PTC (Positive Temperature Coefficient). Located on the second fan housing from the right to sense discharge air temperatures.
  10. **Room Temperature Sensors (S1):** 10K ohm (NTC) and 1 K ohm (PTC). The unit mounted sensors are located in the unit sampling chamber (front center section), where room air is constantly drawn through for prompt response to temperature changes in the room.
  11. **Outdoor Air Temperature Sensors (S3):** 10K ohm (NTC) and 1 K ohm (PTC). The sensors are located in the outdoor air section of the unit before the outdoor air damper.
  12. **Outdoor Air/Return Air Damper Actuator (A1):** spring returned, direct coupled, proportional control (2 to 10 VDC).
  13. **Face and Bypass Damper Actuator (A3):** non-spring returned, proportional control (2 to 10 VDC).
  14. **End of Cycle DDC valves (not shown):** one or two spring return actuators (by others), interface from the terminal board providing 24-volt power. Open/shut signal from UVC (by others).
  15. **24-volt power wiring harness:** from the right to left-hand end compartment through the built-in metal wire raceway terminating at three terminal blocks.
  16. **Low Refrigerant Temperature Sensor (T4):** capillary sensor, helps protect against abnormally low evaporator coil temperatures. Direct Expansion (DX) units only (not shown).

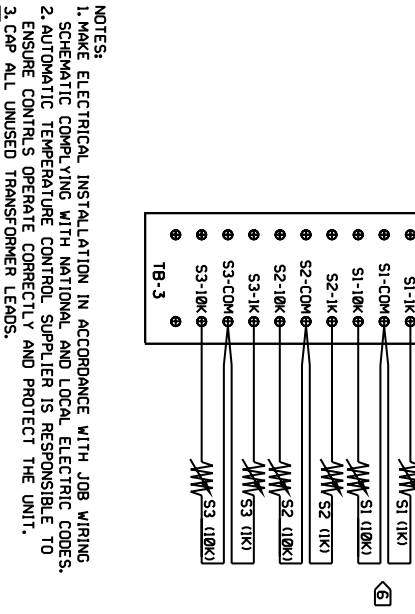
**Figure 113: Component Locations (Vertical Floor Unit Shown)**



# Digital Ready Face and Bypass Control

1 —  
2 —  
3 —  
4 —  
5 —  
6 —  
7 —  
8 —  
9 —  
10 —  
11 —  
12 —  
13 —  
14 —  
15 —  
16 —  
17 —  
18 —  
19 —  
20 —  
21 —  
22 —  
23 —  
24 —  
25 —  
26 —  
27 —

SYMBOL	DESCRIPTION	LINE NUMBER
A1	ACTUATOR-F.A./R.A.	1
A2	ACTUATOR-FACE & BYPASS	12
FA/FB	FUSE - CONTROL	3
M	MOTOR - FAN	4
R2	RELAY-ACTUATOR VALVE	8
SI	SENSOR-ROOM AIR	12
S2	SENSOR-DISCHARGE AIR	16
S3	SENSOR-OUTDOOR AIR	18
SW1	SWITCH - DISCONNECT	2
TE1	TERMINAL BOARD	3
TE2	TERMINAL BOARD	15
TE3	TERMINAL BOARD	15
TE4	TERMINAL BOARD	15
TE5	TERMINAL BOARD	15
TE6	TERMINAL BOARD	15
TE7	TERMINAL BOARD	15
TE8	TERMINAL BOARD	15
TE9	TERMINAL BOARD	15
TE10	TERMINAL BOARD	15
TE11	TERMINAL BOARD	15
TE12	TERMINAL BOARD	15
TE13	TERMINAL BOARD	15
TE14	TERMINAL BOARD	15
TE15	TERMINAL BOARD	15
TE16	TERMINAL BOARD	15
TE17	TERMINAL BOARD	15
TE18	TERMINAL BOARD	15
TE19	TERMINAL BOARD	15
TE20	TERMINAL BOARD	15
TE21	TERMINAL BOARD	15
TE22	TERMINAL BOARD	15
TE23	TERMINAL BOARD	15
TE24	TERMINAL BOARD	15
TE25	TERMINAL BOARD	15
TE26	TERMINAL BOARD	15
TE27	TERMINAL BOARD	15
TE28	TERMINAL BOARD	15
TE29	TERMINAL BOARD	15
TE30	TERMINAL BOARD	15
TE31	TERMINAL BOARD	15
TE32	TERMINAL BOARD	15
TE33	TERMINAL BOARD	15
TE34	TERMINAL BOARD	15
TE35	TERMINAL BOARD	15
TE36	TERMINAL BOARD	15
TE37	TERMINAL BOARD	15
TE38	TERMINAL BOARD	15
TE39	TERMINAL BOARD	15
TE40	TERMINAL BOARD	15
TE41	TERMINAL BOARD	15
TE42	TERMINAL BOARD	15
TE43	TERMINAL BOARD	15
TE44	TERMINAL BOARD	15
TE45	TERMINAL BOARD	15
TE46	TERMINAL BOARD	15
TE47	TERMINAL BOARD	15
TE48	TERMINAL BOARD	15
TE49	TERMINAL BOARD	15
TE50	TERMINAL BOARD	15
TE51	TERMINAL BOARD	15
TE52	TERMINAL BOARD	15
TE53	TERMINAL BOARD	15
TE54	TERMINAL BOARD	15
TE55	TERMINAL BOARD	15
TE56	TERMINAL BOARD	15
TE57	TERMINAL BOARD	15
TE58	TERMINAL BOARD	15
TE59	TERMINAL BOARD	15
TE60	TERMINAL BOARD	15
TE61	TERMINAL BOARD	15
TE62	TERMINAL BOARD	15
TE63	TERMINAL BOARD	15
TE64	TERMINAL BOARD	15
TE65	TERMINAL BOARD	15
TE66	TERMINAL BOARD	15
TE67	TERMINAL BOARD	15
TE68	TERMINAL BOARD	15
TE69	TERMINAL BOARD	15
TE70	TERMINAL BOARD	15
TE71	TERMINAL BOARD	15
TE72	TERMINAL BOARD	15
TE73	TERMINAL BOARD	15
TE74	TERMINAL BOARD	15
TE75	TERMINAL BOARD	15
TE76	TERMINAL BOARD	15
TE77	TERMINAL BOARD	15
TE78	TERMINAL BOARD	15
TE79	TERMINAL BOARD	15
TE80	TERMINAL BOARD	15
TE81	TERMINAL BOARD	15
TE82	TERMINAL BOARD	15
TE83	TERMINAL BOARD	15
TE84	TERMINAL BOARD	15
TE85	TERMINAL BOARD	15
TE86	TERMINAL BOARD	15
TE87	TERMINAL BOARD	15
TE88	TERMINAL BOARD	15
TE89	TERMINAL BOARD	15
TE90	TERMINAL BOARD	15
TE91	TERMINAL BOARD	15
TE92	TERMINAL BOARD	15
TE93	TERMINAL BOARD	15
TE94	TERMINAL BOARD	15
TE95	TERMINAL BOARD	15
TE96	TERMINAL BOARD	15
TE97	TERMINAL BOARD	15
TE98	TERMINAL BOARD	15
TE99	TERMINAL BOARD	15
TE100	TERMINAL BOARD	15



MOTOR SIZE	SW2 TERM. NUMBER	X1 LEAD COLOR PER UNIT SIZE (CFM)				
		750	1000	1250	1500	2000
1/4 HP	HI	BRN	BLK	BLK	ORG	-
	MED	BLU	BRN	BRN	YEL	-
1/3 HP	HI	BLU/WHIT	BLU	BLU	BLK	-
	MED	BLU	BLU	BLU	BLU	-
1/2 HP	HI	RED	RED	RED	RED	YEL
	MED	BRN	BRN	BRN	BLK	BLU
2 1/2 HP	HI	YEL	YEL	YEL	YEL	BLK
	LOW	YEL	YEL	YEL	YEL	BLK

**CAUTION**

Refer to unit wiring diagram located on the right front panel, for actual wiring.

106117203 REV A

## Digital Ready Unit Mounted Temperature Sensor Specifications

A 10 K ohm Negative Temperature Coefficient (NTC) sensor and a 1 K ohm Positive Temperature Coefficient sensor is provided for the discharge air, outdoor air and room air temperature measurement. They are located next to each other in the air stream as shown in [Figure 114](#). Each is wired to the terminal strip separately so that the Automatic Temperature Control contractor may select the appropriate sensor for the application.

### 10 K ohm NTC Sensor

The 10 K ohm NTC sensor is constructed from stainless steel with an epoxy seal and twisted wire leads.

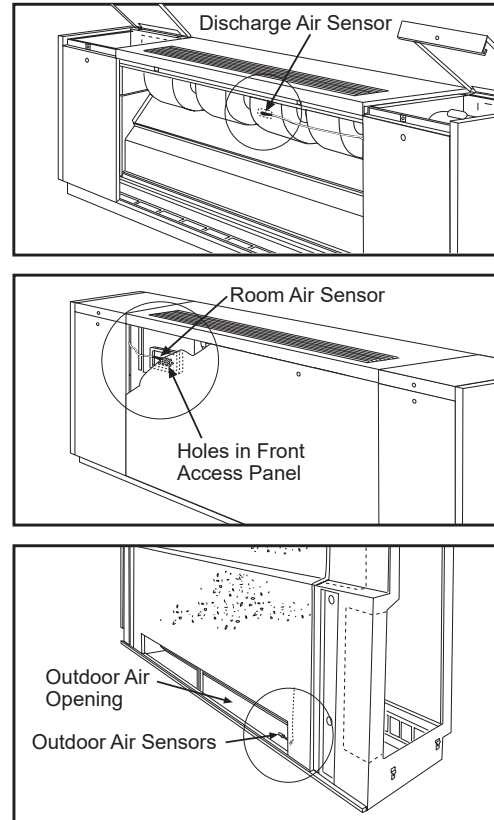
**Type:** 10K ohm @ 25°C  
**Accuracy:** ±0.2°F, 40°F - 80°F  
 ±0.36°F, 32°F - 158°F

### 1 K ohm PTC Sensor

The 1 K ohm sensor is a shrink-wrap encapsulated, PTC silicon sensing element with stranded, tinned copper wire leads (#22 AWG).

**Type:** 1035 ohm @ 25°C  
**Accuracy:** ±0.9°F, 5°F - 167°F

**Figure 114: Sensor Locations**



**Table 36: Temperature Sensors Resistance Values**

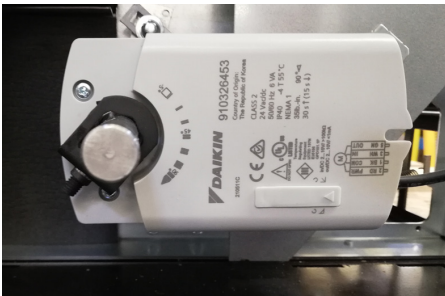
10 K ohm (NTC)	Temperature (°C)	-40	-20	0	20	25	30	40	50	60
	Resistance (ohms)	337200	97130	32660	12490	10000	8056	5326	3602	2489
1 K ohm (PTC)	Temperature (°C)	-40	-20	0	20	25	30	40	50	60
	Resistance (ohms)	613	727	855	997	1035	1074	1153	1237	1323

## Digital Ready – Damper Actuator Specifications

### Outdoor Air/Return Air Damper (OAD) Actuator

The outdoor air/return air damper actuator is a unit mounted, direct coupled, proportional control actuator that spring returns the outdoor air damper shut upon a loss of power. The actuator provides proportional damper control based on a 2 to 10 VDC input (scaled to 2-6 VDC for vertical configurations and 2-8 VDC for horizontal configurations) from the DDC Unit Ventilator Controller (UVC). Rotation is clockwise to open OA, close RA.

**Figure 115: Outdoor Air Damper Actuator**



### Face & Bypass Damper Actuator

The Face & Bypass damper actuator is a unit mounted, direct coupled, non-spring returned actuator used for the modulation of the face and bypass damper. The actuator provides proportional damper control based on a 2 to 10 VDC input from the DDC Unit Ventilator Controller (UVC). Refer to the wiring diagram for proper installation of the resistor. The gears can be manually disengaged with a button on the actuator cover. Rotation is counterclockwise to bypass air around coil.

**Figure 116: Face & Bypass Actuator**



**Table 37: Actuators Technical Data**

Actuator Type	Power Supply	Power Consumption	Transformer Sizing	Torque	Running Time	Direction of Rotation
Face & Bypass Damper Actuator	24 VAC ±20% 50/60 HZ	1.2 Watts 2.1 VA	3 VA (class 2 power source)	44 in-lb	90 sec	Reversible with built in switch.
Outdoor Air / Return Air Damper Actuator	24 VAC ±20% 50/60 HZ	Running: 4 Watt 6 VA Holding: 2 Watt 3.6 VA	8 VA (class 2 power source)	35 in-lb	90° with motor 30s 90° with spring return 15s	Spring: reversible with CW/CCW mounting. Motor: reversible with built in switch.

# Digital Ready Unit Electrical Connections

**⚠ WARNING**  
Rigorously adhere to field wiring procedures regarding proper lockout and tagout of components.

**⚠ WARNING**  
To avoid electrical shock, personal injury or death:  
1. Installer must be qualified, experienced technician.  
2. Disconnect power supply before installation to prevent electrical shock and damage to equipment.  
3. Make all connections in accordance with electrical wiring diagrams, and in compliance with national and local codes. Use copper conductors only.  
4. Do not exceed ratings of the device. This is a low voltage device: Never apply more than 12VAC/VDC to any lead or damage will result.  
5. Avoid locations where excessive moisture, corrosive fumes, or vibrations are present.

See [Table 38](#), and refer to Digital Ready component details on [page 51](#) and the job-specific electrical drawings before proceeding with field power and control wiring. See also the wiring diagram provided on the unit ventilator right front access panel.

In addition, those unit ventilators equipped with optional electric heating coil have electric heating coil power connections at right end only.

## Procedure

1. Provide power supply to right end compartment to match unit nameplate.

**⚠ CAUTION**  
Use copper conductors only. Use of aluminum conductors may result in equipment failure and overheating hazards. All wiring in right hand compartment must be class 1.

2. Wire leads provided from unit ventilator electric connection box to load side of unit power switch (switch provided by Daikin Applied). The junction box has 1" (25mm) and 2" (51mm) knockouts, located 10-1/2" (267mm) from right end of unit.

**Figure 118: Terminal Strip**



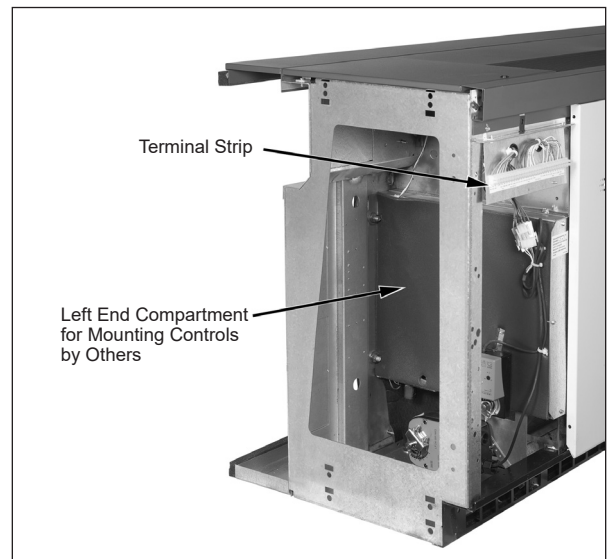
3. Provide ground wire from grounding screw in switch junction box to switch ground terminal.
4. Wire field power supply to line side of unit power switch. Wire ground conductor to switch ground terminal.
5. Mount unit power switch in switch junction box and install switch cover plate (provided).
6. Refer to [Figure 122 on page 61](#). (A) shows switch location for valve control units and (B), (C) and (D) show location for Face & Bypass control units. (B) is for 208, 230 and 265 volt units.
7. See [Figure 118](#) for terminal strip designations.

**Table 38: Floor AV Electrical Data/Motor Data and Unit Amp without electric heat**

Unit Series	CFM (Nom.)	L/s	Motor HP	Watts	Unit Current #			
					115V	208V	230V	265V
S07	750	354	1/4	164	1.8	1.0	0.9	0.8
S10	1000	472	1/4	244	3.1	1.7	1.5	1.3
S13	1250	590	1/4	306	3.5	1.9	1.8	1.5
S15	1500	708	1/4	334	3.7	2.0	1.8	1.6

# Amps at unit voltage, 60 Hz, single phase

**Figure 117: Unit Left End Compartment and Terminal Strip**





## Controls by Others Components

Daikin Applied unit ventilators come with factory installed components and wiring. It facilitates the field hookup of controls by others, capable of providing the standard ASHRAE II cycle that are compatible with these factory installed and pre-wired components.

### **CAUTION**

It is the responsibility of the Automatic Temperature Control supplier to ensure the controls operates correctly and protect the unit.

Controls by others option consists of the following components which are factory provided and wired where indicated:

- 1 **Unit Main Power “On-Off” switch:** disconnects main power to the unit. Non-fused power interrupt switch (S1)
- 2 **Fuse(s):** fan motor, auto transformer and control transformer have the hot line(s) protected by factory installed fuse(s).
- 3 **Three (3) speed HIGH-MEDIUM-LOW-OFF motor fan speed switch (SW2):** wired to auto transformer (X1), to provide fan speed/air delivery.
- 4 **Factory installed Low Air Temperature (limit T6 - freezestat):** across leaving air side of hydronic heating coil. Cuts out below  $38^{\circ}\text{F} \pm 2^{\circ}\text{F}$  and automatically resets above  $45^{\circ}\text{F} \pm 2^{\circ}\text{F}$ . Responds when any 15% of the capillary length senses these temperatures.

### **CAUTION**

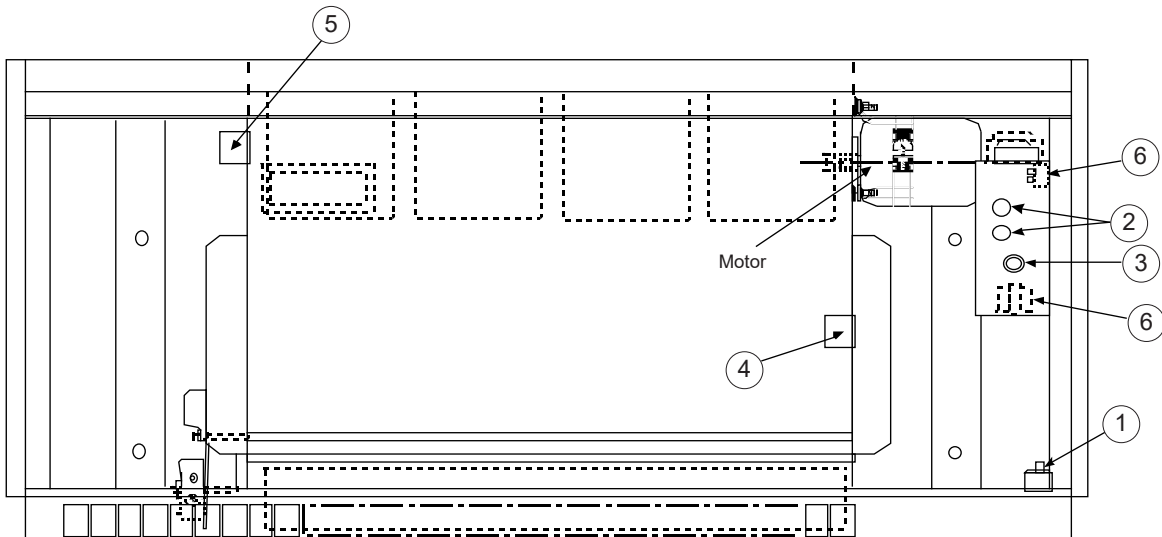
It is the responsibility of the Automatic Temperature Control supplier to ensure the T6 freezestat is incorporated properly to protect the unit.

- 5 **Low Refrigerant Temperature Sensor (T4 - capillary sensor):** for Direct Expansion (DE) coils the unit is supplied with a (T4) sensor, located on the entering air side of the direct expansion coil. T4 cuts out below  $34^{\circ}\text{F} \pm 2^{\circ}\text{F}$  and automatically resets above  $38^{\circ}\text{F} \pm 2^{\circ}\text{F}$ . Responds when any 15% of the capillary length senses these temperatures.
- 6 **24 Volt, NEC Class 2 Transformer:** Units with a Direct Expansion (DE) coil are supplied with a 50VA 24 volt power (X2), with a factory installed 5 minute timer delay relay (TDR) (located inside Unit Power Box). Units with a ECM fan motor are supplied with a 75VA 24 volt power transformer.

### **CAUTION**

It is the responsibility of the Automatic Temperature Control supplier to ensure that T4 and R4 are incorporated properly to protect the unit.

**Figure 119: Controls by Others Unit Power and Junction Box Connection Location**



## Controls by Others - Variable Airflow

An optional EC motor with “variable fan speed control” allows a field provided DDC controller to modulate the unit airflow between 50% and 100% of nominal unit airflow in a single zone variable air volume sequence. In continuous fan mode the benefits of Single Zone VAV include sound reduction, energy savings, and consistent and precise temperature control for improved comfort with better air mixing and less stratification. In humid climates, the ability to deliver a wide range of fan speeds is particularly effective for de-humidification.

**Note:** *This option is not available with MicroTech controls.*

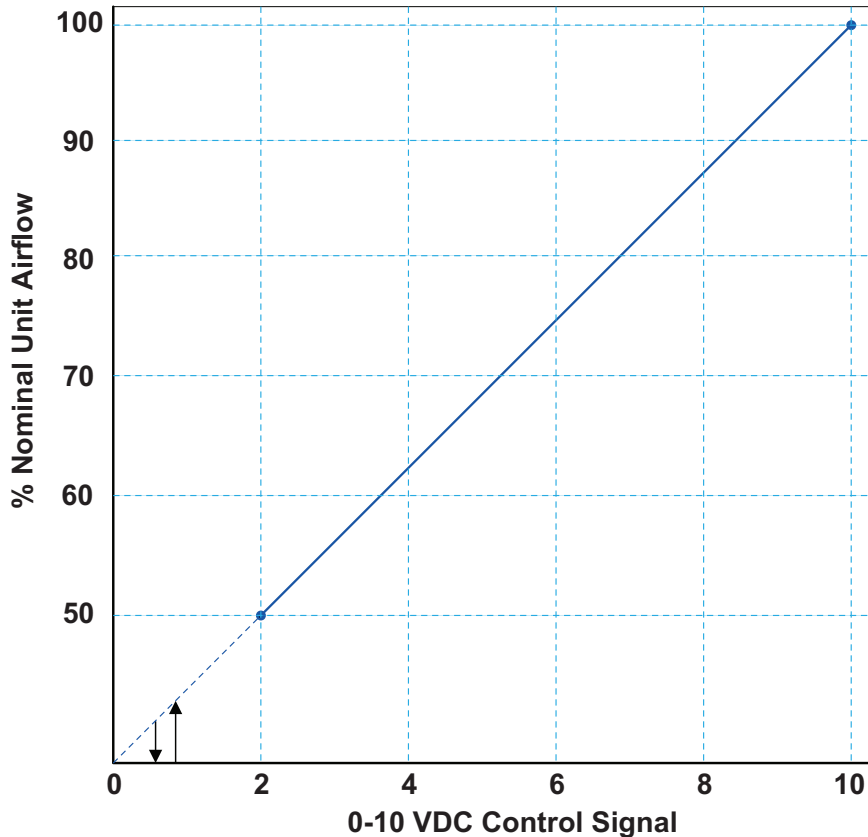
## Making Control Connections

For field provided control wiring connections refer to the appropriate control wiring schematic.

Connect the field supplied controller to the harness provided. A 0-10VDC fan control signal must be provided between ground and wire 33. For RPM/data out signal, connect controller to wire 34.

The variable fan speed scale is linear between a minimum 50% airflow at 2vdc and a maximum 100% airflow at 10vdc. Reducing the input signal to 0vdc will cause the motor to turn off. Care should be taken when using variable airflow on units with DX cooling as lower airflow may increase the risk of coil freeze-up. Variable airflow control should not be used on units with electric heat.

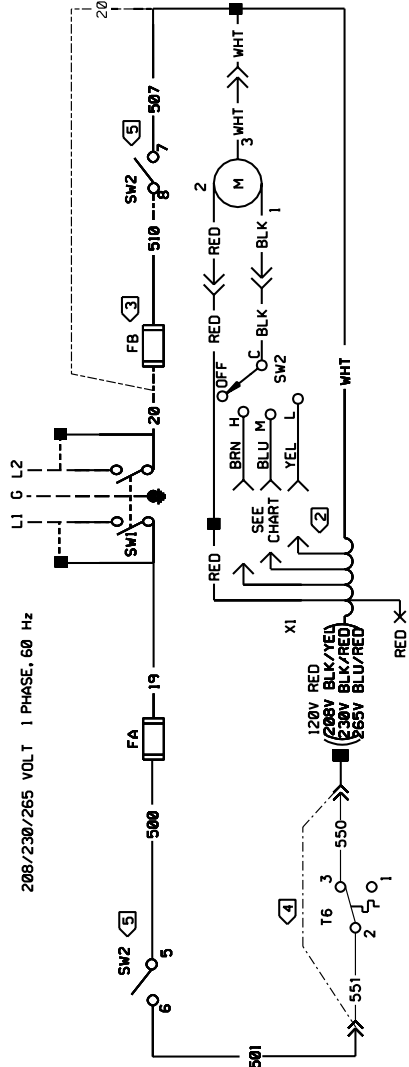
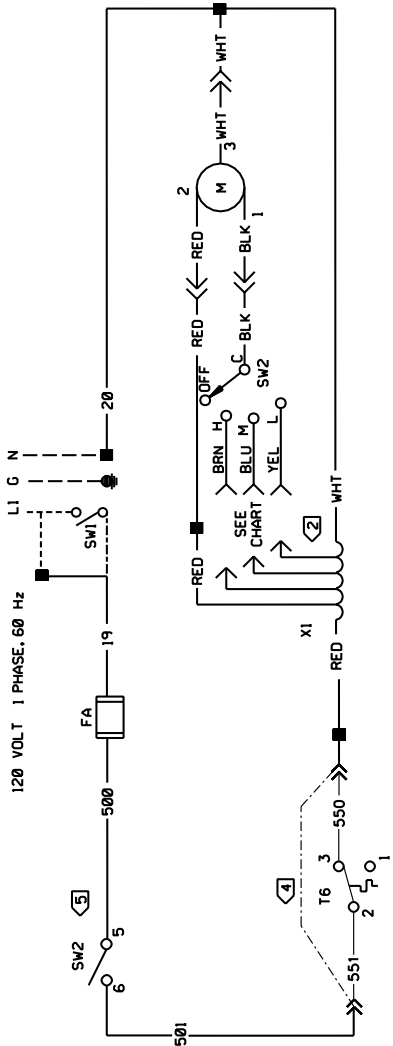
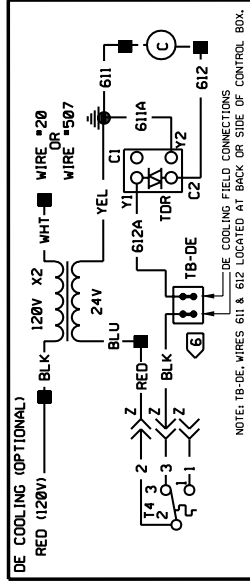
**Figure 120: 0-10VDC Variable Fan Speed Control**





# Controls by Others – Field Installed

MOTOR SIZE	SW2 TERM. NUMBER	X1 LEAD COLOR PER UNIT SIZE (CFM)
1/4 HP (AV UNITS)	HI	750 BLU
	MED	1000 YEL
	LOW	1250 WHT/GRN
1/6 HP (AH UNITS)	HI	1500 GRY/BLK
	MED	PNK
	LOW	YEL
		GRY/BLK
		GRY
		PNK
		WHT/GRN
		GRY
		PNK
		WHT/GRN
		GRY/BLK
		BLU
		YEL



- NOTES:
1. MAKE ELECTRICAL INSTALLATION IN ACCORDANCE WITH JOB WIRING SCHEMATIC COMPLYING WITH NATIONAL AND LOCAL ELECTRIC CODES.
  2. CAP ALL UNUSED TRANSFORMER LEADS.
  3. FUSE FB, SW2, WIRE 510 & 507 FURNISHED ON 208/230 VOLT UNITS ONLY.
  4. T6, WIRES 550 & 551 FURNISHED ONLY ON UNITS WITH HOT WATER OR CHILLED WATER, ALL OTHERS CONNECT TRANSFORMER WIRE TO WIRE # 501.
  5. SW2 CONTACTS 5, 6 AND 7, 8 OPEN ONLY WHEN SW2 IS IN OFF POSITION.
  6. AUTOMATIC TEMPERATURE CONTROL CAN BE WIRED TO TB-DE FOR DE COOLING OPERATION.
- TYPICAL OPERATION IS TO WIRE FROM THE TB-DE TO A NORMALLY OPEN RELAY WITH THE RELAY CLOSING ON CONTROL CALL FOR COOLING.
- FOR ADDITIONAL INFORMATION, CONTACT MCOUAY APPLICATIONS.

SYMBOL	DESCRIPTION	LINE NUMBER
C	CONTACTOR, COMPRESSOR (BY OTHERS)	13
FA/FB	FUSE - CONTROL	3, 12
M	MOTOR - FAN	5, 14
SW1	SWITCH - DISCONNECT	3, 12
SW2	SWITCH - ON-OFF & FAN SPEED	6, 15
T4	THERMOSTAT DE COIL LOW LIMIT 30°	13
T6	THERMOSTAT COIL LOW TEMP 38°	8, 16
TB-DE	TERMINAL BOARD FOR DE CONTACTOR	14
TDR	TIME DELAY (LOW VOLTS)	5 MIN
X1	TRANSFORMER- MOTOR SPEED	7, 14
X2	TRANSFORMER 40 VA CLASS 2	11

LEGEND	
→	PLUG IN
○	COMP TIE POINT
—	SPLICE
⊗	OPTIONAL WIRING
⊙	TAP CONN.
•	WIRED BY OTHERS
•	WIRED BY AAF
⊕	TERMINAL
⊕	WIRED WIRE
⊕	GROUND

⚠ CAUTION

Refer to unit wiring diagram located on the right front panel, for actual wiring. Improper wiring can cause equipment and property damage.

056606832 REV. 0A

## Controls by Others – Electrical Connections

### **WARNING**

Rigorously adhere to field wiring procedures regarding proper lockout and tagout of components.

### **WARNING**

- To avoid electrical shock, personal injury or death:
1. Installer must be qualified, experienced technician.
  2. Disconnect power supply before installation to prevent electrical shock and damage to equipment.
  3. Make all connections in accordance with electrical wiring diagrams, and in compliance with national and local codes. Use copper conductors only.
  4. Do not exceed ratings of the device. This is a low voltage device: Never apply more than 12VAC/VDC to any lead or damage will result.
  5. Avoid locations where excessive moisture, corrosive fumes, or vibrations are present.

See [Table 33 on page 46](#), [Figure 122 through Figure 124](#) and the job-specific electrical drawings before proceeding with field power and control wiring. See also the wiring diagram provided on the unit ventilator right front access panel.

Unit ventilators equipped with an optional electric heating coil have electric heating coil power connections at right end only.

### Procedure

1. Provide power supply to right end compartment to match unit nameplate.

### **CAUTION**

Use copper conductors only. Use of aluminum conductors may result in equipment failure and overheating hazards. All wiring in right hand compartment must be class 1.

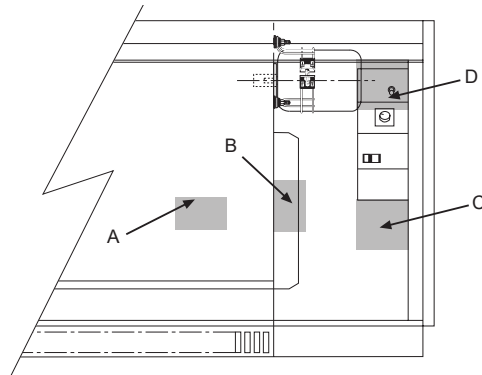
2. Wire leads provided from unit ventilator electric connection box to load side of unit power switch (switch provided by Daikin Applied). The junction box has 1"(25mm) and 2"(51mm) knockouts, located 10-1/2"(267mm) from right end of unit.
3. Provide ground wire from grounding screw in switch junction box to switch ground terminal.
4. Wire field power supply to line side of unit power switch. Wire ground conductor to switch ground terminal.
5. Mount unit power switch in switch junction box and install switch cover plate (provided).

6. On units with electric heat, the 2 pole unit power switch is replaced by a 3 pole switch and is mounted in the location as shown in [Figure 122](#). (A) shows switch location for valve control units and (B), (C) and (D) show location for Face & Bypass control units. (B) is for 208, 230 and 265 volt units. (C) shows location for 460 volt units. Also, on electric heat units with controls by others, wiring to the field mounted controller is done in the left end compartment. See specific wiring diagram for details. The unit comes with wiring that requires relay controls by others

### **CAUTION**

It is the responsibility of the Automatic Temperature Control supplier to ensure that the proper electric heat control components are installed, and operate correctly to protect the unit.

**Figure 122: Electric Heat Unit Power Switch Locations**



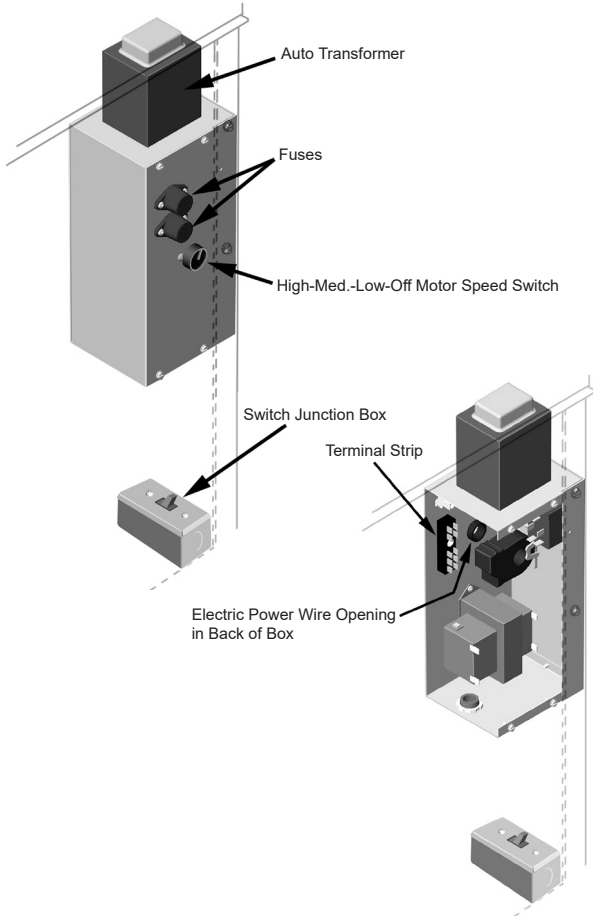
**Table 39: Floor AV Electrical Data/Motor Data and Unit Amp without Electric Heat**

Unit Series	CFM (Nom.)	L/s	Motor HP	Watts	Unit Current #			
					115V	208V	230V	265V
S07	750	354	1/4	216	2.2	1.2	1.1	1.0
S10	1000	472	1/4	277	2.8	1.6	1.4	1.3
S13	1250	590	1/4	335	3.3	1.9	1.7	1.5
S15	1500	708	1/4	445	4.4	2.6	2.3	2.0

# Amps at unit voltage, 60 Hz, single phase

**Note:** See [Electric Heating - PSC Motor on page 64](#), [Table 38 on page 56](#) and [Table 39](#).

**Figure 123: Controls by Others Unit Power and Junction Box Connection Location**



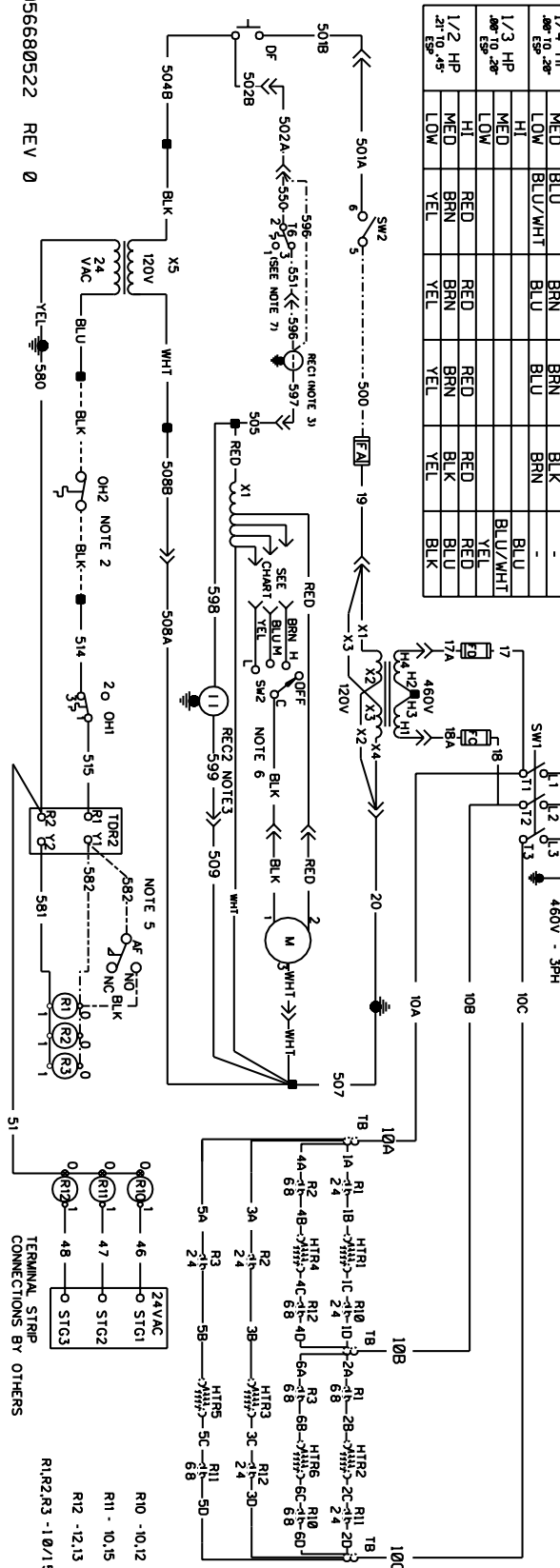


# Electric Heat Wiring Diagram – Typical

Figure 124: 460 Volt, 60 Hz, 3 Phase

1  
2  
3  
4  
5  
6  
7  
8  
9  
10  
11  
12  
13  
14  
15  
16  
17  
18  
19  
20  
21  
22  
23  
24  
25  
26  
27  
28  
29  
30  
31  
32  
33  
34  
35  
36  
37  
38

MOTOR SIZE	SW2 TERM. NUMBER	X1 LEAD COLOUR	PER UNIT SIZE (CFM)
1/4 HP 1000-2000	HI BRN	BLK	1500
	MED BLU	BRN	BLK
	LOW BLU/WHT	BLU	BRN
1/3 HP 2000-3000	HI		
	MED		
	LOW		
1/2 HP 3000-4500	HI	RED	RED
	MED BRN	BRN	BLK
	LOW YEL	YEL	YEL



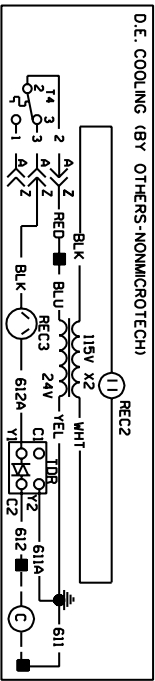
- NOTES:
1. MAKE ELECTRICAL CONNECTIONS IN ACCORDANCE WITH JOB WIRING SCHEMATIC COMPLYING WITH NATIONAL & LOCAL CODES.
  2. OH2 FURNISHED ON CEILING UNITS ONLY. WIRE 514 CONNECTED TO X5 BLU WHEN OH2 IS NOT FURNISHED.
  3. REC1 & REC2 & REC3 & TOR2 FURNISHED WHEN CONTROLS BY OTHERS.
  4. TYPICAL ELECTRIC HEAT ELEMENT WIRING SHOWN. REFER TO LABEL ON FRONT OF UNIT FOR SPECIFIC WIRING WHEN ADDITIONAL ELEMENTS ARE USED.
  5. AIR FLOW SWITCH (AF) USED ONLY ON SIZE 8000 UNITS.
  6. SW2 ONLY ON UNITS WITH HOT WATER OR CHILLED WATER.
  7. SW2 CONTRACTS 5, 6 AND 7, 8 OPEN ONLY WHEN SW2 IS IN OFF POSITION.
  8. SW2 CONTRACTS 9, 6 AND 7, 8 OPEN ONLY WHEN SW2 IS IN OFF POSITION.
  9. NUMBERS ALONG RIGHT SIDE DESIGNATE THE LOCATION OF THE CONTRACTS BY LINE NUMBER.

LEGEND

PLUG IN	COMP. TIE POINT
SPLICE	OPTIONAL WIRING
TERMINAL CONN.	WIRED BY OTHERS
FACTORY WIRE	FACTORY WIRED
CAPPERED WIRE	GROUND

**CAUTION**

Refer to unit wiring diagram located on the right front panel, for actual wiring. Improper wiring can cause equipment and property damage.



- LEGEND
- SYMBOL DESCRIPTION
- D SW2 SWITCH-ON/OFF FRONT
- F1 FUSE-CONTROL
- F2A/F2C FUSE - HEATER OR TERMINAL BLOCK (NOTE 4) SETPOINT OR TB
- HTR1/6 HEATERS SEE NOTE 4)
- M MOTOR - ROOM AIR FAN
- OH1/2 THERMOSTAT - HILIMIT (SEE NOTE 2)
- R1/R3 RELAYS - BACKUP (SEE NOTE 4)
- R10/R13 RELAYS MAIN
- REC1 RECEPTACLE - DAY-NIGHT (OPT)
- REC2 RECEPTACLE - DIVER (OPT)
- REC3 RECEPTACLE - DIVER (OPT)
- REC4 RECEPTACLE - DIVER (OPT)
- SW1 SWITCH - ON-OFF AND FAN SPEED
- SW2 THERMOSTAT-O.E. COIL LOW LIMIT (OPT)
- T4 THERMOSTAT-LOW LIMIT (CNTS BY OTHERS)(OPT)
- TDR RELAY-TIME DELAY
- TOR2 TRANSFORMER - MOTOR SPEED
- TOR3 TRANSFORMER - CLASS 2 (NOT FURNISHED C.B.O)
- TOR4 TRANSFORMER-POWER
- X4
- ELECTRIC HEAT SEQUENCE
- 1) BACKUP RELAYS R1R2 & R3 ARE ENERGIZED WHEN POWER IS APPLIED.
  - 2) MAIN RELAYS R10, R11 & R12 ARE ENERGIZED WHEN A 24VAC SOURCE IS CONNECTED TO STG1, STG2 & STG3 ON TERMINAL STRIP.
  - 3) ELECTRIC HEAT CAN BE STAGED BY APPLYING THE 24VAC TO THE STAGES (1,2 & 3) AT DIFFERENT TIME INTERVALS.
- TERMINAL STRIP CONNECTIONS BY OTHERS
- R10 -10,12
- R11 -10,15
- R12 -12,13
- R1,R2,R3 -10/15

**⚠ WARNING**

To avoid electrical shock, personal injury or death, be sure that field wiring complies with local and national fire, safety, and electrical codes, and voltage to the system is within the limits shown in the job-specific drawings and unit electrical data plate(s). Power supply to unit must be disconnected when making field connections. Rigorously adhere to field wiring procedures regarding proper lockout and tagout of components.

## Electric Heating - PSC Motor

Table 40: Electrical Data – PSC Motor

Unit Type	AVS	AVS	AVV	AVS	AVS	AVV	AVS	AVS	AVV	AVS	AVS	AVV	
	AVB	AVV	AVR	AVB	AVV	AVR	AVB	AVV	AVR	AVB	AVV	AVR	
CFM	750			1000			1250			1500			
Indoor Fan Motor HP	0.25			0.25			0.25			0.25			
# of Electric Heater Elements	—	3	6	—	3	6	—	3	6	—	3	6	
115-60-1	Indoor Fan Motor Nameplate Amps	3.2	—	—	3.2	—	—	3.2	—	—	3.2	—	—
	Electric Heater Amps	—	—	—	—	—	—	—	—	—	—	—	—
	Unit Minimum Circuit Ampacity	4.00	—	—	4.00	—	—	4.00	—	—	4.00	—	—
	Max Fuse Size or Circuit Breaker	15	—	—	15	—	—	15	—	—	15	—	—
208-60-1	Indoor Fan Motor Nameplate Amps	3.2	3.2	3.2	3.2	3.2	3.2	3.2	3.2	3.2	3.2	3.2	3.2
	Electric Heat KW	—	6.0	12.0	—	8.0	16.0	—	10.0	20.0	—	12.0	24.0
	Electric Heater Amps	—	28.8	57.7	—	38.5	76.9	—	48.1	96.2	—	57.7	115.4
	Unit Minimum Circuit Ampacity	2.30	38.25	74.38	2.30	50.38	98.38	2.30	62.38	122.50	2.30	74.38	146.50
230-60-1	Indoor Fan Motor Nameplate Amps	3.2	3.2	3.2	3.2	3.2	3.2	3.2	3.2	3.2	3.2	3.2	3.2
	Electric Heat KW	—	5.5	11.0	—	7.4	14.7	—	9.2	18.4	—	11.0	22.1
	Electric Heater Amps	—	25.0	50.0	—	33.3	66.7	—	41.7	83.3	—	50.0	100.0
	Unit Minimum Circuit Ampacity	2.00	33.25	64.50	2.00	43.63	85.38	2.00	54.08	106.13	2.00	64.50	127.00
265-60-1	Indoor Fan Motor Nameplate Amps	3.2	3.2	3.2	3.2	3.2	3.2	3.2	3.2	3.2	3.2	3.2	3.2
	Electric Heat KW	—	5.5	11.0	—	7.4	14.7	—	9.2	18.4	—	11.0	22.1
	Electric Heater Amps	—	21.7	43.3	—	28.9	57.8	—	36.1	72.2	—	43.3	86.6
	Unit Minimum Circuit Ampacity	1.80	28.88	55.88	1.80	37.88	74.00	1.80	46.88	92.00	1.80	55.88	110.00
208-60-3	Indoor Fan Motor Nameplate Amps	—	3.2	3.2	—	3.2	3.2	—	3.2	3.2	—	3.2	3.2
	Electric Heat KW	—	6.0	12.0	—	8.0	16.0	—	10.0	20.0	—	12.0	24.0
	Electric Heater Amps	—	16.7	33.3	—	22.2	44.4	—	27.8	55.5	—	33.3	66.7
	Unit Minimum Circuit Ampacity	—	23.13	43.88	—	30.00	57.75	—	37.00	71.63	—	43.88	85.63
230-60-3	Indoor Fan Motor Nameplate Amps	—	3.2	3.2	—	3.2	3.2	—	3.2	3.2	—	3.2	3.2
	Electric Heat KW	—	5.5	11.0	—	7.4	14.7	—	9.2	18.4	—	11.0	22.1
	Electric Heater Amps	—	14.5	28.9	—	19.3	38.5	—	24.1	48.2	—	28.9	57.8
	Unit Minimum Circuit Ampacity	—	20.06	38.13	—	26.09	50.13	—	32.13	62.25	—	38.13	74.25
460-60-3	Indoor Fan Motor Nameplate Amps	—	3.2	3.2	—	3.2	3.2	—	3.2	3.2	—	3.2	3.2
	Electric Heat KW	—	5.5	11.0	—	7.4	14.7	—	9.2	18.4	—	11.0	22.1
	Electric Heater Amps	—	7.2	14.5	—	9.6	19.3	—	12.0	24.1	—	14.5	28.9
	Unit Minimum Circuit Ampacity	—	10.04	19.13	—	13.04	25.09	—	16.05	31.13	—	19.06	37.13
460-60-3	Max Fuse Size or Circuit Breaker	—	15	20	—	15	30	—	20	35	—	20	40

# Electric Heating - EC Motor

Table 41: Electrical Data – EC Motor

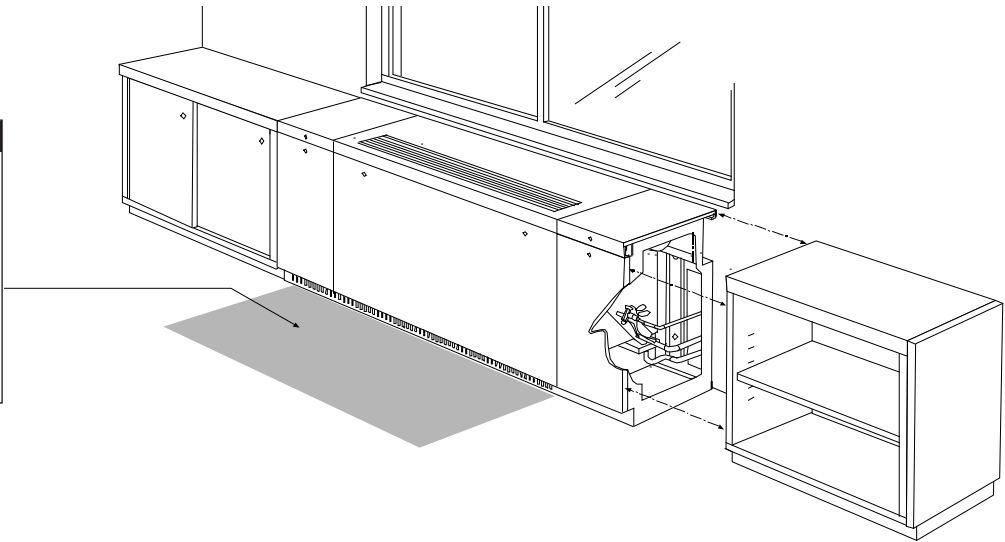
Unit Type		AVS AVB AVV AVR	AVS AVV AVR	AVV AVR	AVS AVB AVV AVR	AVS AVV AVR	AVV AVR	AVS AVB AVV AVR	AVS AVV AVR	AVV AVR	AVS AVB AVV AVR	AVS AVV AVR	AVV AVR
CFM		750			1000			1250			1500		
Indoor Fan Motor HP		0.33			0.33			0.33			0.33		
# Elect Heat Elements		–	3	6	–	3	6	–	3	6	–	3	6
115-60-1	Indoor Fan Motor Nameplate Amps	5.0	—	—	5.0	—	—	5.0	—	—	5.0	—	—
	Electric Heater Amps	—	—	—	—	—	—	—	—	—	—	—	—
	Unit MCA	6.25	—	—	6.25	—	—	6.25	—	—	6.25	—	—
	Max Fuse Size or Circuit Breaker	15	—	—	15	—	—	15	—	—	15	—	—
208-60-1	Indoor Fan Motor Nameplate Amps	3.0	3.0	3.0	3.0	3.0	3.0	3.0	3.0	3.0	3.0	3.0	3.0
	Electric Heat KW	—	6.0	12.0	—	8.0	16.0	—	10.0	20.0	—	12.0	24.0
	Electric Heater Amps	—	28.8	57.7	—	38.5	76.9	—	48.1	96.2	—	57.7	115.4
	Unit MCA	3.75	39.75	75.88	3.75	51.88	99.88	3.75	63.88	124.00	3.75	75.88	148.00
	Max Fuse Size or Circuit Breaker	15	40	80	15	60	100	15	70	125	15	80	150
230-60-1	Indoor Fan Motor Nameplate Amps	2.8	2.8	2.8	2.8	2.8	2.8	2.8	2.8	2.8	2.8	2.8	2.8
	Electric Heat KW	—	5.5	11.0	—	7.4	14.7	—	9.2	18.4	—	11.0	22.1
	Electric Heater Amps	—	25.0	50.0	—	33.3	66.7	—	41.7	83.3	—	50.0	100.0
	Unit MCA	3.50	34.75	66.00	3.50	45.13	86.88	3.50	55.59	107.63	3.50	66.00	128.50
	Max Fuse Size or Circuit Breaker	15	35	70	15	50	90	15	60	110	15	70	150
265-60-1	Indoor Fan Motor Nameplate Amps	2.6	2.6	2.6	2.6	2.6	2.6	2.6	2.6	2.6	2.6	2.6	2.6
	Electric Heat KW	—	5.5	11.0	—	7.4	14.7	—	9.2	18.4	—	11.0	22.1
	Electric Heater Amps	—	21.7	43.3	—	28.9	57.8	—	36.1	72.2	—	43.3	86.6
	Unit MCA	3.25	30.38	57.38	3.25	39.38	75.50	3.25	48.38	93.50	3.25	57.38	111.50
	Max Fuse Size or Circuit Breaker	15	35	60	15	40	80	15	50	100	15	60	125
208-60-3	Indoor Fan Motor Nameplate Amps	—	3.0	3.0	—	3.0	3.0	—	3.0	3.0	—	3.0	3.0
	Electric Heat KW	—	6.0	12.0	—	8.0	16.0	—	10.0	20.0	—	12.0	24.0
	Electric Heater Amps	—	16.7	33.3	—	22.2	44.4	—	27.8	55.5	—	33.3	66.7
	Unit MCA	—	24.63	45.38	—	31.50	59.25	—	38.50	73.13	—	45.38	87.13
	Max Fuse Size or Circuit Breaker	—	25	50	—	35	60	—	40	80	—	50	90
230-60-3	Indoor Fan Motor Nameplate Amps	—	2.8	2.8	—	2.8	2.8	—	2.8	2.8	—	2.8	2.8
	Electric Heat KW	—	5.5	11.0	—	7.4	14.7	—	9.2	18.4	—	11.0	22.1
	Electric Heater Amps	—	14.5	28.9	—	19.3	38.5	—	24.1	48.2	—	28.9	57.8
	Unit MCA	—	21.63	39.63	—	27.63	51.63	—	33.63	63.75	—	39.63	75.75
	Max Fuse Size or Circuit Breaker	—	25	40	—	30	60	—	35	70	—	40	80
460-60-3	Indoor Fan Motor Amps*	—	5.0	5.0	—	5.0	5.0	—	5.0	5.0	—	5.0	5.0
	Electric Heat KW	—	5.5	11.0	—	7.4	14.7	—	9.2	18.4	—	11.0	22.1
	Electric Heater Amps	—	7.2	14.5	—	9.6	19.3	—	12.0	24.1	—	14.5	28.9
	Unit MCA	—	10.60	19.63	—	13.60	25.69	—	16.61	31.69	—	19.63	37.69
	Max Fuse Size or Circuit Breaker	—	15	20	—	15	30	—	20	35	—	20	40

\* Fan Motor is 115/60/1

**Figure 125: Cabinet(s) Meeting Unit Ventilator (refer to the instructions specific to the installation, included with the cabinets)**

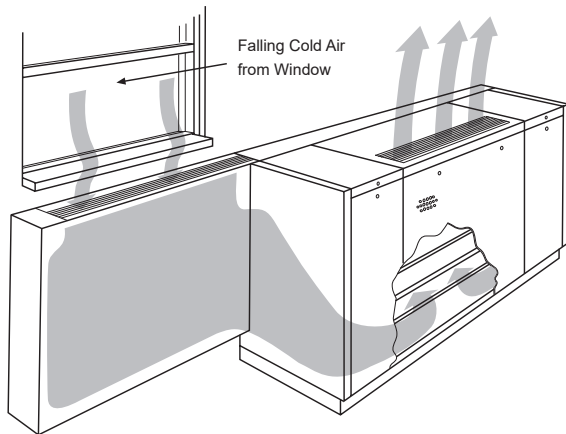
**NOTICE**

Remove debris, dust, dirt, and any obstruction from the area in front of the return air intake grille at the floor (approximately 3' - see shaded area) as this will affect unit performance. If a draftstop system has been installed be sure that all draftstop intake grilles are unobstructed.



## Draftstop™ System/Window Down-draft Installation

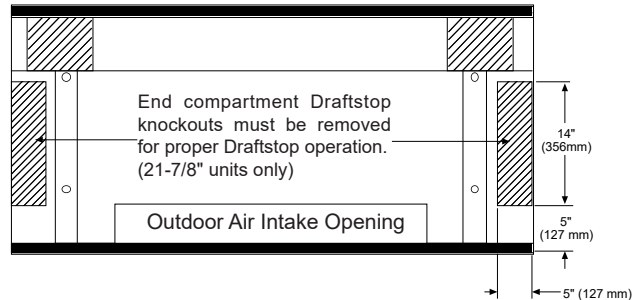
**Figure 126: DraftStop System Concept**



**Table 42: DraftStop Grille Length**

Unit Nominal CFM	20" High DraftStop Wall Enclosure		24" High DraftStop Wall Enclosure or Storage Cabinets	
	Minimum Length (Ft.) Each Side	Maximum Length (Ft.) Each Side	Minimum Length (Ft.) Each Side	Maximum Length (Ft.) Each Side
750	3	13	3	22
1000	4	18	4	30
1250	5	22	5	36
1500	6	25	6	42

**Figure 127: Unit Back Showing knockouts for DraftStop Applications**



Window down-draft protection is recommended for classrooms where the following conditions exist:

1. Window area exceeds 40% of the total outside wall area.
2. Single-pane glass is used.
3. Outside temperatures are below 35°F for a significant portion of the occupied period.

The need for window down-draft protection will not always be so clear cut. Where uncertainty exists, a further check can be made by calculating the window heat loss at an outdoor temperature of 35°F. If estimated window heat loss exceeds 250 Btuh/Ft, window down-draft protection is recommended. If estimated window heat loss is less than 250 Btuh/Ft., the need for down-draft protection is marginal but should not be arbitrarily dismissed.

The “DraftStop” system can be employed even in those marginal applications to provide the occupants comfort without the material installation and operating cost penalty associated with “auxiliary radiation.” The unit ventilator is ordered with the return air intake having a draftstop blockoff to restrict return air flow through the front bottom unit opening, option “30” in field “11” of the model number. This allows drawing of return air through the draftstop enclosure located under the windows. A manually adjustable damper is located beneath each section of DraftStop grille, see [Figure 129](#). This damper is provided so that a uniform air velocity can be achieved throughout the entire length of the DraftStop grille. This simple adjustment is made once by the installer during the final stage of installation.

**Figure 128: Typical Finned Radiation Enclosure (left) And Typical DraftStop Enclosure (right)**



**NOTICE**

The following information is a general outline for installing the Draftstop system. Refer to the specific installation instructions provided with the Draftstop system equipment.

Draftstop is made up of three separate sections as listed below:

1. Upper channel or backplate
2. Mounting components
3. Enclosures and trims

Items 1, and 2 are materials which will be required to start the installation. Item 3 is the completion material and should be stored in a safe area until needed.

The following step-by-step procedures should be adhered to:

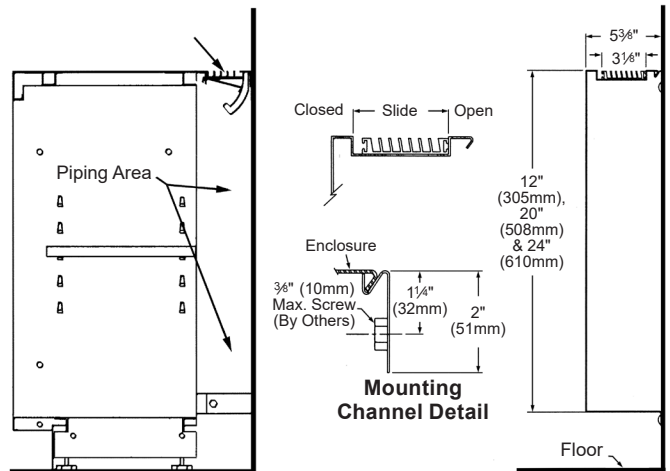
1. Check the area in which the equipment is to be installed and clear away the debris.
2. Review the engineered floor plans or the approved equipment room schedule.
3. Place the proper amount of equipment in each area in accordance with plans or schedule.
4. Proceed to install the equipment as outlined on the following pages. Refer to the installation instructions included with the Draftstop system for more detailed information.

**Upper Channel or Backplate Assembly**

1. Establish a level chalk line on the wall at a height specified for the top of the enclosure. Select mounting hardware which is suitable for the type of wall construction used and mount the upper channel or backplate flush with the chalk line. When mounting, use the prepunched holes and push the hardware through the sponge gasket.
  - a. The upper channel is provided with continuous 5/16" diameter holes on 2" centers for mounting.
  - b. Where used, the backplate assembly consists of a full backplate welded to the back of the upper channel. Fasten the backplate at the bottom as well as at the top.
2. **Wall-to-Wall Application:** Starting at the left side, run the upper channel or backplate along the wall. Note that the upper channel or backplate is installed behind the wall trim as well as the enclosure, because both the enclosure and wall trim rest in the top groove of the upper channel.
3. **Wall-to-End Application:** Run the upper channel or backplate from the wall to a point where the enclosure will end. See Draftstop installation instructions for details of end cap installation.
4. **End-to-End Application:** Run the upper channel or backplate the same length as the enclosure. See Draftstop installation instructions for details of end cap installation.
5. For inside corners, run the upper channel or backplate into the corner, butting the pieces together. If desired, pieces may be stopped short of the corner a maximum of one inch. Refer to the Draftstop installation instructions for details of the corner trim installation.

The Draftstop enclosure and unit ventilator end panel should be matched, to ensure proper airflow. [Table 43](#) through [Table 46](#) show the various end panels available, follow installation instructions included with the end panels.

**Figure 129: Typical DraftStop Enclosure**



**Table 43: 1" (25mm) End Panel Dimensions – Floor Unit Ventilators**

All Dimensions in Inches	16 5/8" (422mm) Deep End Panels	21 7/8" (556mm) Deep End Panels
<b>Top View</b>		
<b>End View With No Cut-out</b>		
<b>End View With 2 1/2" x 7" (64mm x 178mm) Cut-out</b>		
<b>End View With 4" x 18" (102mm x 457mm) Cut-out</b>		
<b>End View With 4" x 22" (102mm x 559mm) Cut-out</b>		
<b>End View With 2" x 5 1/4" (51mm x 133mm) Step Down</b>		

**Table 44: 1" (25mm) End Panel Dimensions – Non-Standard 28" Deep Floor Unit Ventilators**

All Dimensions in Inches	28" (711mm) Deep End Panels
<b>Top View</b>	
<b>End View With No Cut-out</b>	
<b>End View With 2 1/2" x 7" (64mm x 178mm) Cut-out</b>	
<b>End View With 4" x 18" (102mm x 457mm) Cut-out</b>	
<b>End View With 4" x 22" (102mm x 559mm) Cut-out</b>	
<b>End View With 2" x 5 1/4" (51mm x 133mm) Step Down</b>	



**Table 45: 1" (25mm) End Panel Dimensions – Non-Standard 28" Deep Floor Unit Ventilators 6" (152mm) End Panel Dimensions – Floor Unit Ventilators**

All Dimensions in Inches	16 5/8" (422mm) Deep End Panels	21 7/8" (556mm) Deep End Panels
Top View		
End View With No Cut-out		

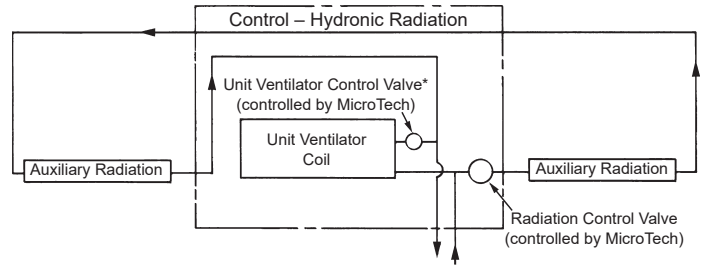
**Table 46: 6" (152mm) End Panel Dimensions – 28" Non-Standard Floor Unit Ventilators**

All Dimensions in Inches	21 7/8" (556mm) Deep End Panels
Top View	
End View With No Cut-out	

## Finned Radiation System

Finned radiation down-draft control is available for those who prefer it. Made of furniture-quality steel and designed to complement the unit ventilator styling, it is particularly appropriate for a building with very large expanses of window where the DraftStop system is not used, and for use in other parts of the building.

**Figure 130: Typical Finned Radiation Piping**



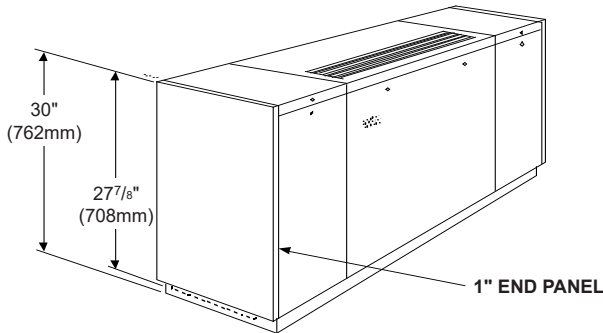
\*Not required with Face & Bypass control

## Installing Unit Ventilator End Panels:

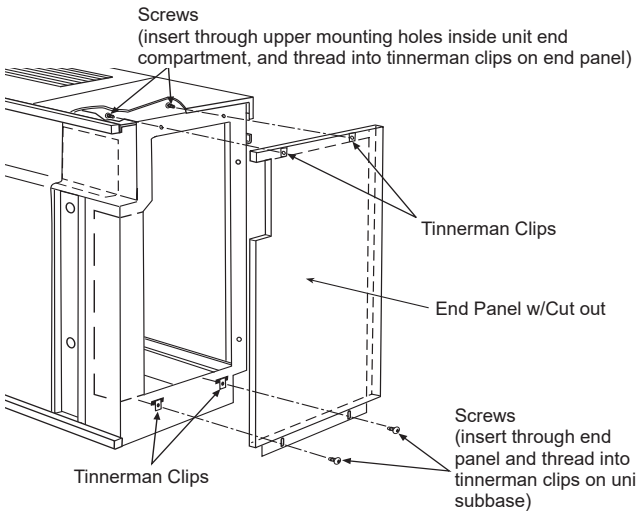
See Figure 131. Accessory end panels are shipped separately with hardware and kickplate, or simulated kickplate adhesive tape used on 16<sup>5</sup>/<sub>8</sub>" units (only). Align each end panel with the top and front edges of the unit ventilator. Attach each end panel to the unit ventilator using the hardware provided.

1. Position (YC-1934) bracket on wall so angle is 5" from end of unit and near bottom (Figure 133).
2. Mark and drill required hole for fastening device (not included).
3. Attach bracket to wall.
4. Attach end panel. Bracket should prevent movement of end panel toward end of unit when pressure is applied to end panel, readjust bracket if necessary.

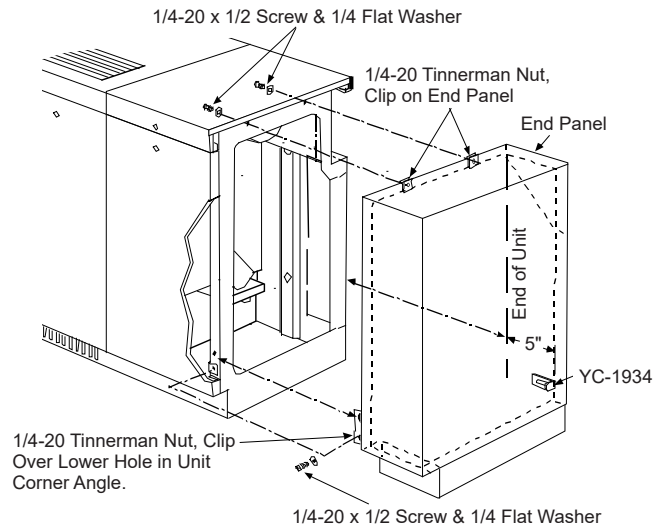
**Figure 131: Install End Panels**



**Figure 132: Install End Panels With Provided Hardware (1" End Panel Shown)**



**Figure 133: Install End Panels With Provided Hardware (6" End Panel Shown)**



## Prepare Unit Ventilator(s) for Start-up

### Battery Backup

The controller battery protects the time clock schedule in the event of a power loss. This battery should be replaced every 3 years with a new CR2032 or equivalent.

### Remove Battery Shipping Tab

Check that board backup battery shipping tab is removed. To remove, grasp tab and gently pull. Battery should be replaced every 3 years of unit service.



Remove Battery Shipping Tab

## Oiling the Fan Shaft End Bearing:

### CAUTION

Do not attempt to operate the unit fans until the fan bearings have been oiled. Oiled bearings provide smooth, and quiet operation of the fan system.

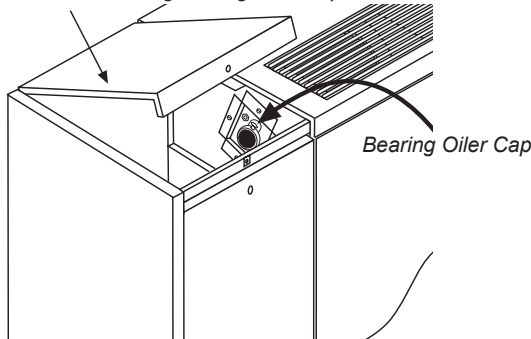
See [Figure 134](#) and [Figure 135](#) for oiling points. Fan shaft may have sleeve type bearing that requires oiling no more than once annually. Check for oil cap to determine which bearing type is present. Units requiring oiling will have an oil cap access to fan shaft bearing through the left top access door (for 750, 1000, 1250 cfm units) or by removing the center panel in the middle of the fan shaft (on size 1500 cfm and larger). Lift the oiler cap. Oil, using a few drops of high grade SAE 20 or 30 non-detergent oil. Oil the bearing every 6-12 months to maintain proper lubrication. Some units are built with permanently sealed bearings that do not require oiling.

### NOTICE

G.E. motor manufacturer recommends not oiling the fan motor.

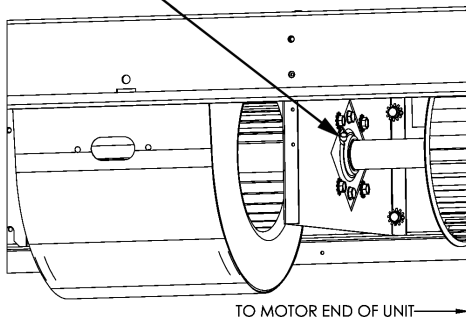
**Figure 134: Oiling Point**

Access To Fan Shaft Bearing Through Left Top Access Door



**Figure 135: Oiling Point for 1500 cfm units**

Bearing Oiler Cap



## Unit Ventilator Start-up

### NOTICE

Remove debris, dust, dirt, and any obstruction from the area in front of the return air intake grille at the floor as this will affect unit performance. If a draftstop system has been installed be sure that all draftstop intake grilles are unobstructed.

1. Before proceeding inspect the fan system, ensure all parts are aligned properly and move freely. Inspect fans and fan discharge area for obstructions. Rotate fan manually. Check that a clean filter is installed and area in front of unit ventilator is free of debris (see [Figure 125 on page 66](#)). All panels should be in place and properly fastened. Check for outdoor air leaks and condensation. Ensure the coil section is properly sealed using the insulating foam donuts supplied.
2. After the unit ventilator has been properly installed, activate unit electrical power and applicable chilled water/hot water/steam/refrigerant systems.
3. Using the applicable control, activate the unit ventilator. Depending on the operating mode selected, the dampers, fans, and other components should operate as needed.
4. Run the unit ventilator for ten minutes, listening and observing. Fans should be operating correctly, and rotating in the proper direction, without unusual noise. Likewise, the unit should be free of sheet metal rattles and / or unusual noises. All panels should be in place and properly fastened, and checked for air leaks and condensation.

## Filter(s)

### CAUTION

Turn off unit before servicing to avoid danger of injury from rotating fans.

Turn off the unit, (fan speed switch or unit on/off switch is located behind the right front end compartment panel). Remove the center front panel, pull out the filter and replace with a clean filter. Replace the center panel and restart the unit.

Filters should be replaced during the first week of placing into service to prevent dirt carry-over into the internals of the unit and back into the classroom, (see [Figure 136](#)). A periodic filter changeout program should be established. Filters should be checked monthly or more often if conditions indicate. Filters are included in all units. Daikin Applied single-use filters are standard on all but electric heat units, which come with permanent wire mesh filters. Permanent wire mesh and renewable media filters are available for non-electric heat units, in lieu of single-use filters.

- Single-use filters feature Amerglas media. They are designed to be used once and discarded.
- Permanent filters are metal filters that may be removed for cleaning and reused numerous times.
- Renewable media filters (Figure 136) consist of a heavy painted metal structural frame and renewable Amerglas media.

**CAUTION**

Electric heat units should **ONLY** use permanent wire mesh filters. Filters other than wire mesh are not intended for electric heat units, and can cause unit damage, property damage or personal injury.

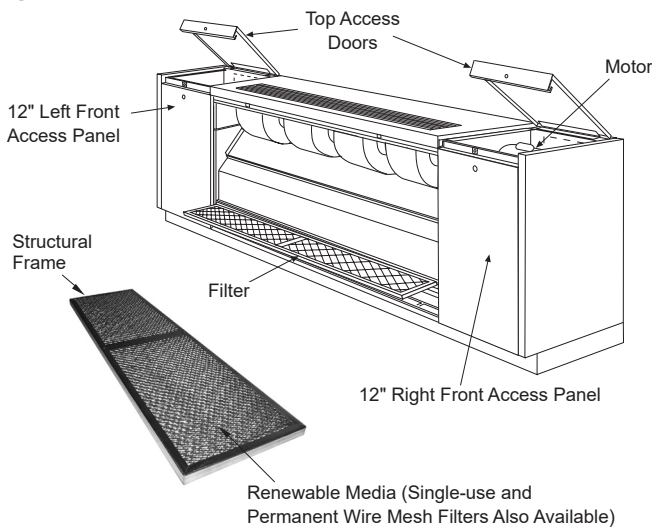
**CAUTION**

Units must have a filter installed when operating. Operation without a filter can compromise unit performance due to build up of dust and dirt on components.

**CAUTION**

Dirty or clogged filters can impact unit performance, resulting in damage to the unit.

**Figure 136: Filter installation**



## Complete Check, Test and Start Procedure

(Included in the shipping envelope in the end compartment of the unit). Provide completed Check, Test and Start procedure to local Daikin Applied representative and to specifying engineer to verify proper start-up was completed.

## Installer/Owner's Responsibility

### *Protect your investment - read carefully*

Your Daikin Applied express written limited warranty does not cover equipment failures that are caused by misuse, abuse, mis-installation, failure to maintain the unit, etc. So, for example, the following damage is not covered by warranty:

1. Progressive damage to machine from failure to check and test at start-up.
2. Damage resulting from handling during installation or damage resulting from transportation.
3. Incorrect or fluctuating power supply.
4. Damage resulting from failure to keep evaporator coil and intake clean.
5. Damage resulting from freezing water or condensate, inadequate or interrupted water supply, use of corrosive water, rearrangement of unit piping system, fouling or restriction of the water circuit by foreign material.
6. Inaccessibility of unit for service or parts installation that prevents proper equipment operation.
7. Damage resulting from the use of the unit in a corrosive atmosphere, i.e., cleaning materials, fumes, etc
8. Damage caused by not cleaning or replacing filters.
9. Damage caused by accident, alteration of unit design, or tampering.

Please complete and return the [Check, Test and Start Form beginning on page 73](#) immediately to protect your warranty.



# Warranty - Check, Test and Start

Form: 5F-4240

Group: **ATS**

Date: **June 2024**

Supersedes: **573882Y**

## Unit Ventilator Warranty Registration Form

Check, test & start procedure for Daikin Applied Unit Ventilators

This form must be completely filled out and the record retained by the sales representative or the owner in order to comply with the terms of the Daikin Applied warranty.

Sales Office: \_\_\_\_\_ S.O.#: \_\_\_\_\_ Date Started: \_\_\_\_\_

Job Name: \_\_\_\_\_ G.O. # \_\_\_\_\_

Job Location: \_\_\_\_\_

Unit Location: \_\_\_\_\_ Unit Tagging: \_\_\_\_\_

Model No: \_\_\_\_\_ Serial No.: \_\_\_\_\_

Supply Voltage: L1/L2 \_\_\_\_\_ L2/L3 \_\_\_\_\_ L3/L1 \_\_\_\_\_ Rated: \_\_\_\_\_

Room Fan Motor Amps: T1: \_\_\_\_\_ RPM \_\_\_\_\_ Nameplate Rating: \_\_\_\_\_

### I. Initial check

- A. Does electrical service correspond to unit nameplate? ..... Yes  No
  - B. Are all electrical power connections tight? ..... Yes  No
  - C. Does all field wiring conform to unit electrical schematic? ..... Yes  No
  - D. Is unit installed per IM bulletin? ..... Yes  No
  - E. Cabinet paint O.K.? ..... Yes  No
  - F. Cabinet bent? ..... Yes  No
  - G. Do outdoor (AEQ, AZU, AZQ & AZR) and indoor fans turn freely? ..... Yes  No
  - H. Are all setscrews on outdoor and indoor fan couplings tight? ..... Yes  No
  - I. Is the fan coupler aligned between the shaft and motor? ..... Yes  No
  - J. Are end bearing bolts on outdoor and indoor fan shaft tight? ..... Yes  No
  - K. Have the fan shaft end bearing and room fan motor been oiled (if applicable)? ..... Yes  No
  - L. Are outdoor air and return air dampers operating properly? ..... Yes  No
  - M. Is the filter clean? ..... Yes  No
  - N. Is there excessive noise or vibration? ..... Yes  No
- If Yes, corrective action (if any) \_\_\_\_\_

### II. Controls check

- A. Does the unit have Daikin Applied controls (MicroTech)? ..... Yes  No
- If No, control company \_\_\_\_\_
- If controls are not by Daikin Applied, skip to Section III.
- B. Condensate disposal system operating O.K.? ..... Yes  No
- C. Does unit start and perform per sequence of operation as stated in OM? ..... Yes  No
- D. If the unit has a unit mounted sensor, has the insulation been removed from the sampling chamber inlet? ..... Yes  No
- E. Are all sensors installed and insulated properly? ..... Yes  No
- F. If the unit has MicroTech controls, room setpoint: \_\_\_\_\_°F Deadband 6° or \_\_\_\_\_°F

### III. Refrigeration system

- A. Has all field piping been leak tested to 100 psig (AVS, AVV, AVR, AHF, AHV, & AHR)? ..... Yes  No
- B. Is expansion valve bulb properly installed and insulated? ..... Yes  No
- C. High pressure control cutout (if applicable) \_\_\_\_\_ psig
- D. Crankcase heater operating O.K.? ..... Yes  No
- E. Reversing valve operating O.K.? ..... Yes  No
- F. Emergency heat operating O.K.? ..... Yes  No
- G. Piping correct (AVS, AVV, AVR, AHF, AHV, & AHR to remote condensing unit)? ..... Yes  No
- H. Checked for refrigerant leaks? ..... Yes  No

### IV. Hydronic piping check

- A. Is unit piping correct (the remainder of this section applies only to units with Daikin Applied controls)? ..... Yes  No
- B. Is the modulating control valve(s) piped correctly (valve controlled units)? ..... Yes  No
- C. Is the modulating control valve(s) placed in the upright position (valve controlled units)? ..... Yes  No
- D. Is 2 - position control valve(s) piped correctly (face and bypass)? ..... Yes  No



**V. Start-up (Readings must be taken at full load conditions)**

- A. Outdoor Fan Motor Amps: T1 \_\_\_\_\_ Nameplate Rating: \_\_\_\_\_
- B. Compressor Amps (Cig): T1 \_\_\_\_\_ T2 \_\_\_\_\_ T3 \_\_\_\_\_ Nameplate Rating: \_\_\_\_\_
- C. Compressor Amps (Htg): T1 \_\_\_\_\_ T2 \_\_\_\_\_ T3 \_\_\_\_\_ Nameplate Rating: \_\_\_\_\_
- D. Refrigerant Pressures Htg./Clg.: Suction: \_\_\_\_\_ / \_\_\_\_\_ Discharge: \_\_\_\_\_ / \_\_\_\_\_
- E. Refrigerant Temperature Htg./Clg.: Suction \_\_\_\_\_ °F/ \_\_\_\_\_ °F Discharge: \_\_\_\_\_ °F/ \_\_\_\_\_ °F
- F. O.A.Temp.: \_\_\_\_\_ °F Super Heat: \_\_\_\_\_ °F Subcooling: \_\_\_\_\_ °F
- G. R.A. Temp. Htg./Clg.: \_\_\_\_\_ °F/ \_\_\_\_\_ °F Discharge Air Temp.: \_\_\_\_\_ °F/ \_\_\_\_\_ °F
- H. Electric Htg. Amp: L1 \_\_\_\_\_ L2 \_\_\_\_\_ L3 \_\_\_\_\_ Total Amp: \_\_\_\_\_
- I. Water Temperature Htg./Clg.: In \_\_\_\_\_ °F/ \_\_\_\_\_ °F Out \_\_\_\_\_ °F/ \_\_\_\_\_ °F

**VI. Performed by:**

Company: \_\_\_\_\_  
Name: \_\_\_\_\_  
Title: \_\_\_\_\_  
Signature: \_\_\_\_\_ Date: \_\_\_\_\_

Comments: \_\_\_\_\_  
\_\_\_\_\_  
\_\_\_\_\_  
\_\_\_\_\_  
\_\_\_\_\_

Service Technician: \_\_\_\_\_  
Contractor Representative: \_\_\_\_\_







### ***Daikin Applied Training and Development***

Now that you have made an investment in modern, efficient Daikin Applied equipment, its care should be a high priority. For training information on all Daikin Applied HVAC products, please visit us at [www.DaikinApplied.com](http://www.DaikinApplied.com) and click on Training, or call 540-248-9646 and ask for the Training Department.

### ***Warranty***

All Daikin Applied equipment is sold pursuant to its standard terms and conditions of sale, including Limited Product Warranty. Consult your local Daikin Applied representative for warranty details. Refer to Form 933-430285Y. To find your local Daikin Applied representative, go to [www.DaikinApplied.com](http://www.DaikinApplied.com).

### ***Aftermarket Services***

To find your local parts office, visit [www.DaikinApplied.com](http://www.DaikinApplied.com) or call 800-37PARTS (800-377-2787). To find your local service office, visit [www.DaikinApplied.com](http://www.DaikinApplied.com) or call 800-432-1342.

This document contains the most current product information as of this printing. For the most up-to-date product information, please go to [www.DaikinApplied.com](http://www.DaikinApplied.com).

Products manufactured in an ISO Certified Facility.