



Installation, Operation, and Maintenance Manual

IOM 1274-3

Group: **Chiller**

Part Number: **IOM1274-3**

Date: **September 2023**

Centrifugal Chillers

Model WSC - B Vintage, HSC, TSC
300 to 1350 Tons (1050 to 4748 kW)
R-134a or R-513A Refrigerant
60/50 Hz



Table of Contents

Introduction	5	Unit Reassembly	30
Hazard Identification Information	5	Operation	35
General Description	6	Dual/Multi-Chiller Operation	35
Installation	7	Sequencing	36
Receiving and Handling	7	Operator Responsibilities	36
Location	8	Unit Enabling/Disabling	36
Operating Limits	9	Human Machine Interface (HMI)	37
Field Insulation	9	Trend History Screen	58
Water Piping	9	Alarms	58
Heat Recovery Condenser Connections	10	Controller Inputs and Outputs	62
Templifier Source Water Piping	10	Unit Startup and Maintenance	64
Water Quality Guidelines	10	Pre-Startup	64
Variable Fluid Flow Rates	11	Routine Maintenance	64
Condenser Water Control	11	Oil Analysis	67
Heat Recovery Chillers	12		
Relief Valves	13		
Oil Coolers	14		
Field Wiring	17		
Surge Capacitors	18		
Building Automation Systems (BAS)	18		
Use with On-Site Generators	18		
Field Wiring, Controls & Starters	19		
Long Term Storage	23		
Retrofit Knockdown	24		

Manufactured in an ISO 9001 & ISO 14001 certified facility

Models TSC and HSC are outside of the AHRI certification program and not optionally certified.



©2023 Daikin Applied, Minneapolis, MN. All rights reserved throughout the world. This document contains the most current product information as of this printing. Daikin Applied Americas Inc. has the right to change the information, design, and construction of the product represented within the document without prior notice. For the most up-to-date product information, please go to www.DaikinApplied.com.
 ™® MicroTech, SiteLine, and Daikin Applied are trademarks or registered trademarks of Daikin Applied Americas Inc. The following are trademarks or registered trademarks of their respective companies: BACnet from American Society of Heating, Refrigerating and Air-Conditioning Engineers, Inc.; Echelon, LonWorks, LonMark, and LonTalk from Echelon Corporation; Modbus from Schneider Electric; and Windows from Microsoft Corporation.



Pre-Start Checklist – Centrifugal Chillers

Must be completed, signed and returned to Daikin Applied service dept. at least 2 weeks prior to requested start date.

Cut Here ✂

Job Name				
Installation Location				
Customer Order Number				
Model Number(s)				
G.O. Number(s)				
Chilled Water	Yes	No	N/A	Initials
Piping Complete				
Water System – flushed, filled, vented; Water treatment in place				
Pumps installed and operational (rotation checked, strainers installed and cleaned)				
Controls operational (3-way valves, face/bypass dampers, bypass valves, etc.)				
Water system operated and tested; flow meets unit design requirement				
Flow switch installed, wired, and calibrated				
Condenser Water	Yes	No	N/A	Initials
Cooling tower flushed, filled, vented; Water treatment in place				
Pumps installed and operational (rotation checked, strainers installed and cleaned)				
Controls (3-way valves, bypass valves, etc.) operable per IM/IOM				
Water system operated and flow balance to meet unit design requirement				
Flow switch installed, wired, and calibrated				
Electrical	Yes	No	N/A	Initials
115 volt service completed, but not connected to control panel (remote mounted starters)				
Line Power Leads connected to starter; load leads (b) run from starter to compressor, ready for connection by Service (Do not connect load leads to starter or compressor terminals). (See Notes 1 & 4)				
All interlock wiring complete and compliant with Daikin Applied specifications				
Starter complies with Daikin Applied specifications				
*Oil cooler solenoid wired to control panel as shown on wiring diagram (See Notes)				
Pump starter and interlocks wired				
Cooling tower fans and controls wired				
Wiring complies with National Electrical Code and local codes (See Note 4)				
Condenser pump starting relay (CP1,2) installed and wired (See Note 3)				
Miscellaneous	Yes	No	N/A	Initials
*Oil cooled water piping complete. (Units with water-cooled oil coolers only)				
Relief valve piping complete (per local codes)				
Thermometers, wells, gauges, control, etc., installed				
Minimum system load of 80% capacity available for testing/adjusting controls				
SiteLine™ cloud-connected controls included and needs to be commissioned				
Document Attached: Technical Breakdown from Daikin Tools				
Document Attached: Final Order Acknowledgement				
Notes: The most common problems delaying start-up and affecting unit reliability are:				
1. Field installed compressor motor power supply leads too small. Questions: Contact the local Daikin Applied sales representative. State size, number and type of conductors and conduits installed:				
a. From Power supply to starter _____				
b. From starter to chiller unit (remote mounted) _____				
2. Centrifugal chillers with water cooled oil coolers must have a 115 volt normally closed water solenoid valve installed in the oil cooler water supply line. Daikin Applied recommends ASCO Type 8210B27 solenoid valve or approved equal and 40-mesh strainer. Daikin Applied does not supply these components.				
3. A 115-volt field-supplied relay (CP1,2) must be used to start/stop condenser water pump on most applications. Cold condenser water must not flow through condenser during compressor off cycle. Provisions have been made in control center for connecting CP relay, but must not have a rating in excess of 100 VA.				
4. Refer to NEC Article 430-22 (a) *Does Not Apply to Magnetic Bearing Chillers (WMC/WME)				

Contractor Representative

Signed: _____
 Name: _____
 Company: _____
 Date: _____
 Phone/Email: _____

Daikin Applied Sales Representative

Signed: _____
 Name: _____
 Company: _____
 Date: _____
 Phone/Email: _____

Introduction

This manual provides installation, operation, and maintenance information for Daikin Applied centrifugal chillers with the MicroTech® II controller.

NOTE: Installation and maintenance are to be performed only by licensed, if required by local codes and regulations, or qualified personnel who are familiar with local codes and regulations and are experienced with this type of equipment.

 **DANGER**

LOCKOUT/TAGOUT all power sources prior to service, pressurizing, de-pressurizing, or powering down the unit. Failure to follow this warning exactly can result in serious injury or death. Disconnect electrical power before servicing the equipment. More than one disconnect may be required to deenergize the unit. Be sure to read and understand the installation, operation, and service instructions within this manual.

 **WARNING**

Electric shock hazard. Improper handling of this equipment can cause equipment damage, personal injury, or death. This equipment must be properly grounded. Connections to and service of the MicroTech control panel must be performed only by personnel that are knowledgeable in the operation of the equipment being controlled.

 **WARNING**

Polyolester Oil, commonly known as POE oil is a synthetic oil used in many refrigeration systems, and may be present in this Daikin Applied product. POE oil, if ever in contact with PVC/CPVC, will coat the inside wall of PVC/CPVC pipe causing environmental stress fractures. Although there is no PVC/CPVC piping in this product, please keep this in mind when selecting piping materials for your application, as system failure and property damage could result. Refer to the pipe manufacturer's recommendations to determine suitable applications of the pipe.

 **CAUTION**

Static sensitive components. A static discharge while handling electronic circuit boards can cause damage to the components. Discharge any static electrical charge by touching the bare metal inside the control panel before performing any service work. Never unplug any cables, circuit board terminal blocks, or power plugs while power is applied to the panel.

Hazard Identification Information

 **DANGER**

Danger indicates a hazardous situation, which will result in death or serious injury if not avoided.

 **WARNING**

Warning indicates a potentially hazardous situations, which can result in property damage, personal injury, or death if not avoided.

 **CAUTION**

Caution indicates a potentially hazardous situations, which can result in minor injury or equipment damage if not avoided.

NOTICE

Notice indicates practices not related to physical injury.

NOTE: Indicates important details or clarifying statements for information presented.

General Description

Daikin Applied Centrifugal Water Chillers are complete, self-contained, automatically controlled fluid chilling units. Each unit is completely assembled and factory tested before shipment.

Each WSC/HSC/TSC unit has one compressor connected to a condenser and evaporator. The chillers use R-134a or R-513A refrigerant and operate at a positive pressure over the entire operation range so no purge system is required.

The controls are pre-wired, adjusted and tested. Only normal field connections such as piping, electrical and interlocks, etc. are required, thereby simplifying installation and increasing reliability. Most necessary equipment protection and operating controls are factory installed in the control panel.

All Daikin Applied centrifugal chillers are factory tested prior to shipment and must be initially started at the job site by a factory trained Daikin Applied service technician. Failure to follow this startup procedure can affect the equipment warranty. The standard limited warranty on this equipment covers parts that prove defective in material or workmanship. Specific details of this warranty can be found in the warranty statement furnished with the equipment.

Templifier TSC models are units that recover heat from a warm fluid source, via the evaporator, and deliver hot water, at a useful temperature, from the condenser to a heating load.

Heat Recovery HSC models are cooling-focused units with heat recovered in a bundle of condenser tubes separate from the cooling tower tube bundle.

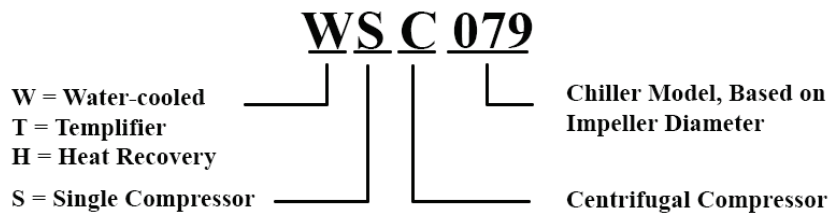
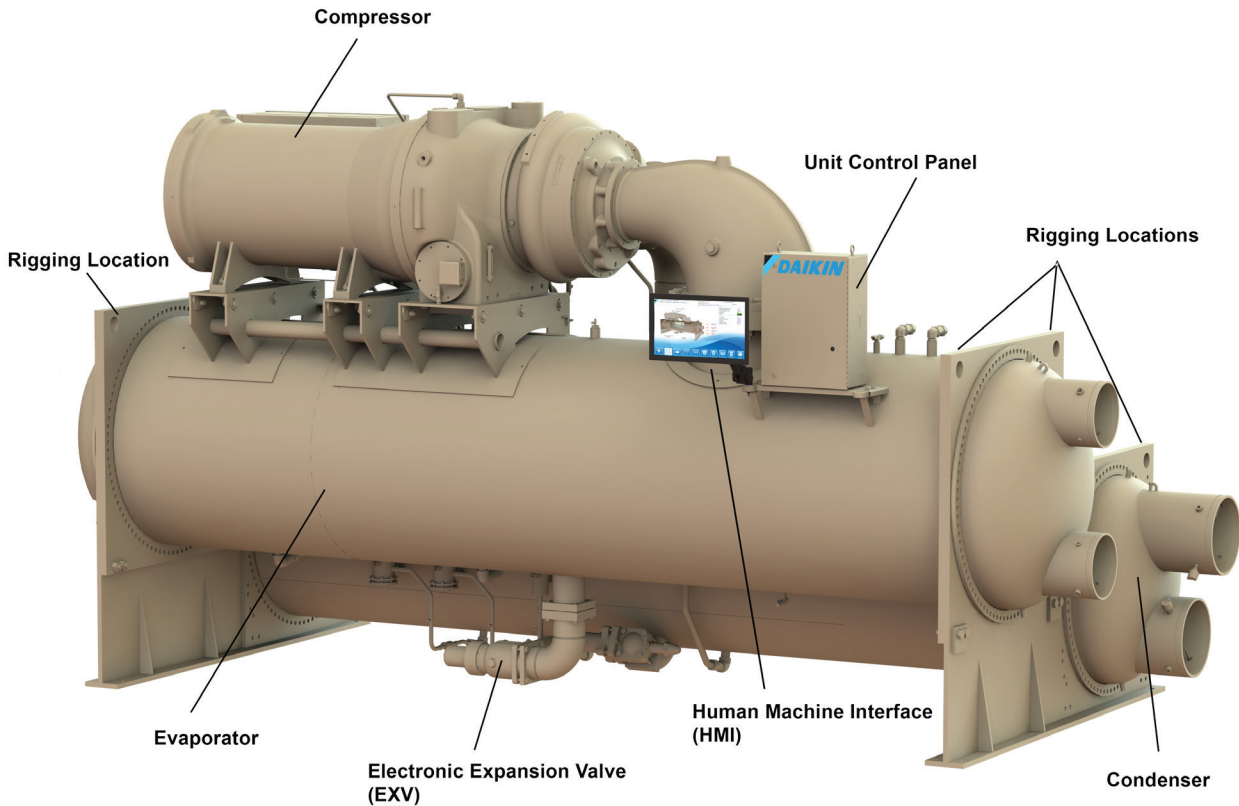

Figure 1: Major Component Locations



Installation

Receiving and Handling

The unit should be inspected immediately after receipt for possible damage. All Daikin Applied centrifugal water chillers are shipped FOB factory and all claims for handling and shipping damage are the responsibility of the consignee. For knockdown options, please review the Knockdown Instruction chapter.

Nameplates

There are several identification nameplates on the chiller:

- The unit nameplate is located on the side of the Unit Control Panel. It has a Style No. and Serial No.; both are unique to the unit. These numbers should be used to identify the unit for service, parts, or warranty questions. This plate also lists the unit refrigerant charge.
- Vessel nameplates are located on the evaporator and condenser, listing National Board Number (NB) and serial number. Either number can identify the vessel (but not the entire unit).
- A compressor nameplate is located on the compressor.

Insulation corners from the evaporator's rigging hole locations are shipped loose and should be glued in place after the unit is finally placed. Neoprene vibration pads are also shipped loose. Check that these items have been delivered with the unit. If so equipped, leave the shipping skid in place until the unit is in its

final position. This will aid in handling the equipment.

Lifting and Rigging

⚠ CAUTION

Extreme care must be used when rigging the unit to prevent damage to the control panels and refrigerant piping. See the certified dimension drawings included in the job submittal for the weights and center of gravity of the unit. If the drawings are not available, consult the local Daikin Applied sales office for assistance.

Spreader bars must be used between the rigging lines to keep lifting straps vertical and prevent damage to the control panels, electrical panels, unit piping, and motor terminal boxes. The unit can be lifted by fastening rigging hooks to the outermost four rigging holes (see Figure 1). The length of the spreader-bars should be equal to, or no more than 1-foot shorter than, the distance between the lifting holes located at opposite ends of the chiller. The unit will require a double spreader-bar of this length capable of supporting 1.5 times the shipping weight of the unit. Separately, all cables and hooks by themselves must also be capable of supporting 1.5 times the shipping weight of the unit.

NOTE: The spreader bars in Figure 2 are a representation only and may not reflect the appearance of the actual spreader bars needed.

If a knockdown option was ordered on the unit, reference the "Retrofit Knockdown" section starting on page 24 for more information.

Figure 2: Unit Lifting and Rigging

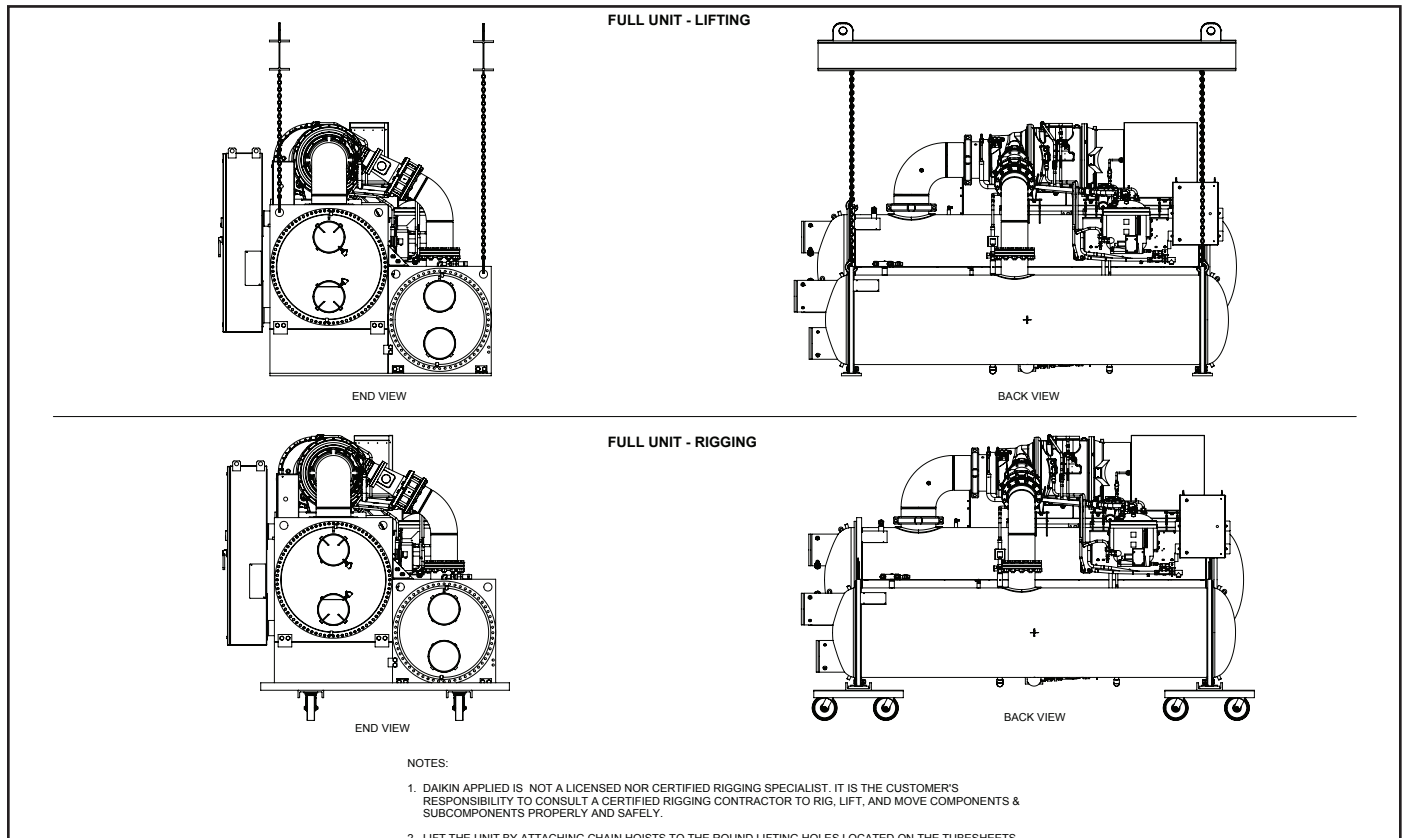

Location

The chillers are designed for indoor installation only. Special procedures must be executed to prevent damage if freezing indoor temperatures are possible.

NOTE: Excessive humidity in the mechanical room should be avoided. A limit of 90% non-condensing humidity should be met to minimize electrical components exposure to water condensing in panels. Humidity levels in the mechanical room, even if lower than 90%, can cause water to condense on/near all cool surfaces and potentially lead to premature component wear. If possible, the mechanical room should be conditioned which can extend the useful lifetime for all mechanical room equipment.

Radiant heat from boilers or piping that would adversely raise component surface temperatures beyond ambient limits must also be avoided.

Table 1: Equipment Room Guidelines

WSC - HSC - TSC	Temperature Range	
	R-513A	R-134a
Equipment room operating temperature:	40-104 °F (4.4-40 °C)	
Equipment room temperature, standby, with water in vessels and oil cooler:	40-104 °F (4.4-40 °C)	
Equipment room temperature, standby, without water in vessels and oil cooler:	0-113 °F (-17.7-45 °C)	

Clearance

The unit must be located to provide adequate service clearance around the unit. See Figure 3 for clearance requirements around the sides of the chiller, including the length of the vessels allowed at one end for tube service. Doors and removable wall sections can be utilized to meet these clearance requirements. There must be a minimum 3-foot clearance above the top of the chiller. The U.S. National Electric Code (NEC) or local codes can require more clearance in and around electrical components and must be checked for compliance.

Mounting

The unit must be mounted on a level concrete or steel base. Make sure that the floor or structural support is adequate to support the full operating weight of the complete unit.

It is not necessary to bolt the unit to the mounting slab or framework; but should this be desirable, 1 1/8" (28.5 mm) mounting holes are provided in the unit support at the four corners.

NOTE: Units are shipped with refrigerant and oil valves closed to isolate these fluids for shipment. Valves must remain closed until start-up by the Daikin Applied technician.

The neoprene vibration pads (shipped loose in the power panel) should be placed under the corners of the unit (unless the job specifications state otherwise). They must be installed so that they are flush with the edges of the unit feet. Most single compressor units have six mounting feet although only the outer four are required. Six pads are shipped and the installer can place pads under the middle feet if desired.

When mounted, the base pad of the unit must be level to within ± 1/2 inch (12.7 mm) across the length and width of the unit.

Figure 3: Minimum Clearances Based on Standard Waterboxes - Representative Schematic

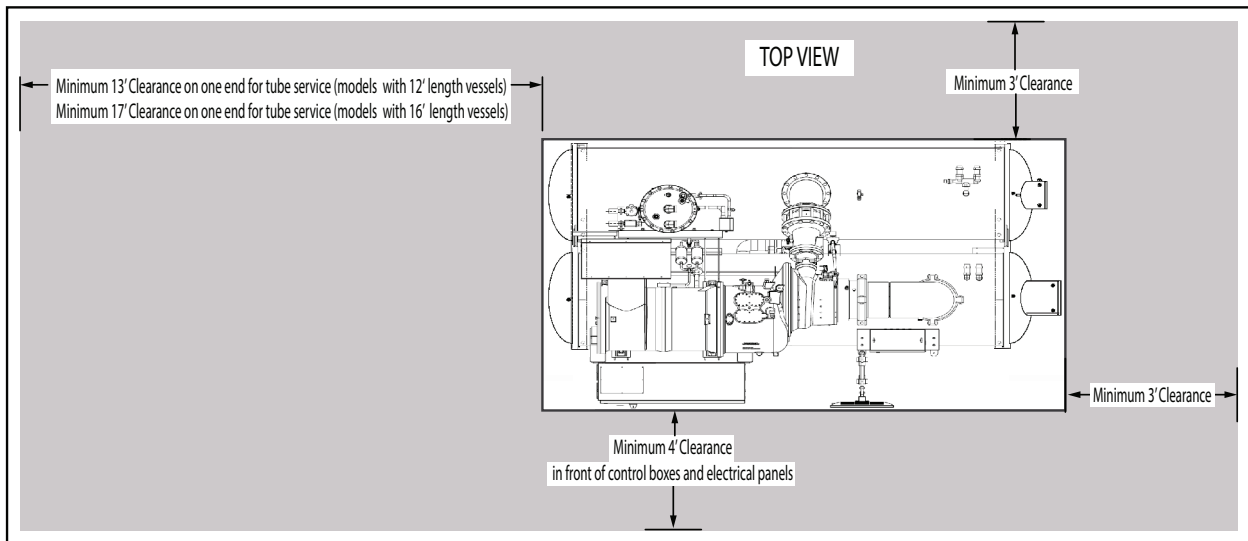

NOTE: Unit configuration may be different than illustrated. Hinged type waterboxes may require more clearance. Consult a Daikin Applied sales representative for details.

Operating Limits

Table 2: Operating/Standby Limits

Acceptable Temperatures (WSC, HSC, TSC) ¹			R-513A		R-134a	
Condition	Component	Description	Min Temp °F (°C)	Max Temp °F (°C)	Min Temp °F (°C)	Max Temp °F (°C)
Standby	Evaporator	Entering Fluid	35 (1.7)	86 (30)	35 (1.7)	90 (32.2)
		Entering Fluid w/ Antifreeze ²	20 (-6.7)	86 (30)	20 (-6.7)	90 (32.2)
	Equipment Room	Air w/ Water in Vessels & Oil Cooler	40 (4.4)	104 (40)	40 (4.4)	104 (40)
		Air w/ no Water in Vessels & Oil Cooler	0 (-17.8)	0 (-17.8)	0 (-17.8)	113 (45)
Startup	Evaporator	Entering Fluid	38 (3.3)	100 (37.8)	38 (3.3)	100 (37.8)
		Entering Fluid w/ Antifreeze ²	20 (-6.7)	100 (37.8)	20 (-6.7)	100 (37.8)
	Condenser	Entering Fluid	35 (1.7)	110 (43.3)	35 (1.7)	111 (43.9)
	Oil Cooler	Entering Fluid	35 (1.7)	80 (26.7)	35 (1.7)	80 (26.7)
	Equipment Room	Air	40 (4.4)	104 (40)	40 (4.4)	104 (40)
Operating	Evaporator	Entering Fluid	38 (3.3)	86 (30)	38 (3.3)	90 (32.2)
		Leaving Fluid	38 (3.3)	60 (15.6)	38 (3.3)	60 (15.6)
		Entering Fluid w/ Antifreeze ²	20 (-6.7)	86 (30)	20 (-6.7)	90 (32.2)
		Leaving Fluid w/ Antifreeze ²	20 (-6.7)	60 (15.6)	20 (-6.7)	60 (15.6)
	Condenser	Entering Fluid	55 (12.8)	104 (40)	55 (12.8)	105 (40.6)
		Leaving Fluid	See Note ³	110 (43.3)	See Note ³	111 (43.9)
	Oil Cooler	Entering Fluid	35 (1.7)	80 (26.7)	35 (1.7)	80 (26.7)
	Equipment Room	Air	40 (4.4)	104 (40)	40 (4.4)	104 (40)

NOTES:

- 1 Contact a Daikin Applied representative for performance at specific operating conditions, as some limits depend on unit configuration (including heating and heat recovery mode limits)
- 2 Antifreeze temperature limits must have appropriate glycol concentration
- 3 Depends on specific selection/rating conditions

Field Insulation

If the optional factory-installation of thermal evaporation insulation is not ordered, insulation should be field installed to reduce heat loss and prevent condensation from forming. Insulation should cover:

- the evaporator barrel, tube sheet, and waterboxes.
- the suction line from the top of the evaporator to the compressor inlet flange.
- the compressor support brackets welded to the evaporator.
- the liquid line from the expansion valve to the evaporator inlet, including the expansion valve.
- the part load balance valve to the evaporator.

Approximate total square footage of insulation surface required for individual packaged chillers is tabulated by code and can be found in [Table 4](#). Condenser references included for TSC model units only.

Table 4: Insulation Area Required for Vessels

Vessel Code	Insulation Area sq. ft. (m2)
E2612 / C2612	102 (9.4)
E3012 / C3012	115 (10.6)
E3612 / C3612	129 (11.9)
E4212 / C4212	148 (13.7)
E4216 / C4216	264 (24.5)
E4816 / C4816	302 (28.1)

Water Piping

All evaporators and condensers have OGS-type grooved water connections (adhering to Standard AWWA C606) or optional flange connections. The installing contractor must provide matching mechanical connections. Be sure that water inlet and outlet connections match certified drawings and nozzle markings. PVC piping should not be used.

⚠ WARNING

Polyolester Oil, commonly known as POE oil is a synthetic oil used in many refrigeration systems, and is present in this Daikin Applied product. POE oil, if ever in contact with PVC/CPVC, will coat the inside wall of PVC/CPVC pipe causing environmental stress fractures. Although there is no PVC/CPVC piping in this product, please keep this in mind when selecting piping materials for your application, as system failure and property damage could result. Refer to the pipe manufacturer's recommendations to determine suitable applications of the pipe.

⚠ CAUTION

If welding is to be performed on the mechanical or flange connections:

1. Remove the solid-state temperature sensor, thermostat bulbs, and nozzle mounted flow switches from the wells to prevent damage to those components.
2. Properly ground the unit or severe damage to the MicroTech® unit controller can occur.

NOTE: ASME certification will be revoked if welding is performed on a vessel shell or tube sheet.

The water heads can be interchanged (end for end) so that the water connections can be made at either end of the unit. If this is done, use new head gaskets and relocate the control sensors.

Field installed water piping to the chiller must include:

- air vents at the high points.
- a cleanable water strainer upstream of the evaporator and condenser inlet connections.
- a flow proving device for both the evaporator and condenser. Flow switches, thermal dispersion switches, or Delta-P switches can be used. Note that thermal dispersion flow switches are factory installed. Additional flow switches can be used only if they are connected in series with the ones already provided. Connect additional flow switches in series between original flow switch inputs. Calibration of thermal dispersion flow switches is discussed on [page 69](#).
- water pressure gauge connection taps and gauges at the inlet and outlet connections of both vessels for measuring water pressure drop.
- sufficient shutoff valves to allow vessel isolation. The chiller must be capable of draining the water from the evaporator or condenser without draining the complete system.
- Piping must be supported to eliminate weight and strain on the fittings and connections.
- Chilled water piping must be adequately insulated.

It is recommended that field installed water piping include:

- thermometers at the inlet and outlet connections of both vessels.

⚠ CAUTION

When common piping is used for both building heating and cooling modes, care must be taken to provide that water flowing through the evaporator cannot exceed 100°F. Water this hot can damage controls or cause the relief valve to discharge refrigerant.

NOTE: This product, in its standard configuration, is equipped with a shell and tube evaporator with carbon steel shell and copper tubes. The water or other fluid used in contact with the wetted surfaces of the heat exchangers must be clean and non-corrosive to the standard materials of construction. Daikin Applied makes no warranty as to the compatibility of fluids and materials. Non-compatible fluids may void the equipment warranty. If the compatibility of the fluid with the standard materials of construction is in question, a professional corrosion consultant should administer the proper testing and evaluate compatibility.

Heat Recovery Condenser Connections



The tower connections on heat recovery units are always the inboard pair of connections. In the image to the left, the condenser connections are “left-hand” when viewed from the front of the unit (Unit Control Panel and Interface Panel side), so in this case, the right-hand condenser connections would be for the tower. If the condenser connections were on the other end (“right-hand”), the tower connections would be the left-hand pair of connections.

Templifier Source Water Piping

Templifier evaporator water can come from various sources and care must be used to avoid sources that can cause corrosion, fouling, or accumulation of debris in the heat exchanger. For open water loop applications, an intermediate heat exchanger between the source water and unit evaporator may be desirable.

Water Quality Guidelines

The water quality provided by the owner/occupant/operator/user to a chiller system should minimize corrosion, scale buildup, erosion, and biological growth for optimum efficiency of HVAC equipment without creating a hazard to operating personnel or the environment. Strainers must be used to protect the chiller systems from water-borne debris. Daikin Applied will not be responsible for any water-borne debris

damage or water side damage to the chiller heat exchangers due to improperly treated water.

Water systems should be cleaned and flushed prior to chiller installation. Water testing and treatment should be verified during initial chiller installation/commissioning and maintained on a continuous basis by water treatment professionals (see Limited Product Warranty).

 CAUTION
<p>The improper use of detergents, chemicals, and additives in the chiller system water may adversely affect chiller performance and potentially lead to repair costs not covered by warranty. Any decision to use these products is at the discretion of the owner/occupant/operator/user and as such they assume full liability/responsibility for any damage that may occur due to their use.</p>

Vessel Drains at Startup

The unit is drained of water at the factory. Drain plugs for each vessel head are shipped separately in the control box. Units are shipped with the drain plug in the top water box drain hole and no plug in the bottom drain hole. Install the bottom drain plugs prior to filling the vessel with fluid. See [Figure 4](#).

Figure 4: Drain Plug Installation

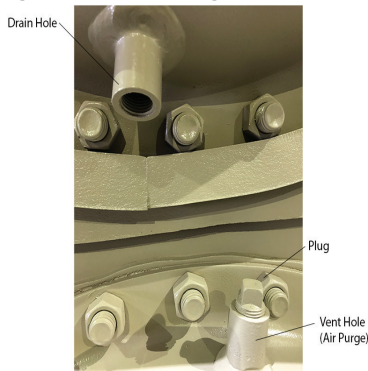

Flow Switches

Thermal dispersion flow switches are factory-installed and wired. See the Field Wiring Diagram on page 32 or on the cover of the control panel for proper connections. The purpose of the water flow switches is to prevent compressor operation until such time as both the evaporator water and condenser water pumps are running and flow is established. If alternate flow switches must be furnished, water flow interlock terminals are provided on the Unit Control Panel terminal strip. Both flow switches must be calibrated in the field before the unit can be started. See [“Flow Switch Installation and Calibration” on page 69](#) for further information.

Variable Fluid Flow Rates

Both excessively high and low fluid flow rates should be avoided. Extremely high fluid flow rates and high tube velocities will result in high fluid pressure drops, high pumping

power, and potential tube erosion or corrosion damage. Extremely low fluid flow rates and low velocities should also be avoided as they will result in poor heat transfer, high compressor power, sedimentation and tube fouling.

If it is decided to vary the evaporator or condenser water flow rate, the flow rate should not exceed the minimum or maximum limits. During startup, the rate of change for the evaporator flow rate should not exceed 50% of the current value per minute. For normal unit operation, the evaporator flow rate change should use 10% of the current value per minute as guidance.

System Water Volume

All chilled water systems need adequate time to recognize a load change, respond to that load change and stabilize, without undesirable short cycling of the compressors or loss of control. In air conditioning systems, the potential for short cycling usually exists when the building load falls below the minimum chiller plant capacity or on close-coupled systems with very small water volumes.

Some of the things the designer should consider when looking at water volume are the minimum cooling load, the minimum chiller plant capacity during the low load period and the desired cycle time for the compressors.

Assuming that there are no sudden load changes and that the chiller plant has reasonable turndown, a rule of thumb of “gallons of water volume equal to two to three times the chilled water gpm flow rate” is often used.

A properly designed storage tank should be added if the system components do not provide sufficient water volume.

System Pumps

Operation of the chilled water pump can be to 1) cycle the pump with the compressor, 2) operate continuously, or 3) start automatically by a remote source.

The cooling tower pump must cycle with the machine. The holding coil of the cooling tower pump motor starter must be rated at 115 volts, 60 Hz, with a maximum volt-ampere rating of 100. A control relay is required if the voltage-ampere rating is exceeded. See [“Figure 17: Centrifugal Field Wiring Schematic” on page 20](#) or in the cover of control panel for proper connections.

All interlock contacts must be rated for no less than 10 inductive amps. The alarm circuit provided in the control center utilizes 115-volts AC. The alarm used must not draw more than 10 volt amperes.

Condenser Water Control

Condenser water control is an important consideration in chiller plant design since condenser water temperature will directly impact chiller operation and efficiency. When the ambient wet bulb temperature is lower than peak design, the entering condenser water temperature from the cooling tower can be allowed to fall, improving chiller performance. However, operational issues may occur when the condenser water temperatures are either too high or too low. The WSC chiller

provides several options to assist the chiller plant designer in providing the optimum control of condenser water temperature.

Cooling Tower Control

Control of the cooling tower is required to maintain stability and avoid operational issues. This can be achieved through a BAS or by using the MicroTech® II controller. For systems utilizing a common condenser water loop for multiple purposes, the BAS contractor must provide the control but use of the MicroTech® II output signal is still recommended.

The preferred cooling tower control utilizes a variable speed fan. MicroTech® II will provide a control signal to determine the proper fan speed. It can also control up to three stages of fan cycling. Note that fan cycling can cause cooling tower water temperature to fluctuate as fans stage on/off, potentially adding instability to the system.

Special consideration must be given to starting the chiller when cold condenser water is present, such as with inverted starts or changeover from free (tower) cooling to mechanical cooling. Daikin Applied chillers will start with entering condenser water temperature as low as 55°F (42.8° C) providing the chilled water temperature is below the condenser water temperature. The minimum entering condenser water temperature while operating is a function of the leaving chilled water temperature and load. It is required that some method be used to control the condenser water to maintain proper head pressure as indicated by the MicroTech® II controller. Refer to “[Tower Control Settings](#)” on page 51 for details in the HMI.

Each of the following acceptable methods can be controlled by the MicroTech® II or through a BAS utilizing the MicroTech® II output signals:

1. Three-Way Bypass Valve Operation

A traditional method for building condenser pressure at startup with colder condenser water is with the use of a three-way bypass valve. The device blends warmer water leaving the condenser with cooler water from the cooling tower at the condenser inlet. The bypass valve position will change until full flow from the tower to the condenser is obtained. The MicroTech® II provides only the valve position control signal. Main power to drive the valve actuator must be provided by the installer. The three-way valve should be located close to the chiller within the equipment room to minimize the water volume.

2. Two-Way Valve Operation

Another condenser control method is to use a modulating two-way control valve located on the outlet connection of the condenser. The valve will be nearly closed at startup to restrict water flow, which keeps generated heat in the condenser until an acceptable minimum condenser pressure is reached. As heat builds, the valve will open slowly until a full flow condition from the cooling tower is established. A separate power source is required to provide power to the valve actuator.

NOTE: To ensure proper operation, caution should be used when utilizing the two-way valve option.

3. VFD Operating with a Condenser Water Pump

A third method of condenser control for startup is utilizing a variable frequency drive with the condenser water pump. The speed will change as directed by the MicroTech® II output signal until design flow is reached. Speed adjustments may be required during the initial chiller startup as determined by the service technician.

NOTE: Not using the MicroTech® II logic to control valves and variable frequency drives may result in system instability, capacity reduction, and issues starting the chiller with cold condenser water temperature.

Condenser Pump Sequencing

It is recommended to utilize the logic built into the MicroTech® II controller to start the condenser pump. MicroTech® II has the capability to operate a primary pump and a secondary standby pump. The condenser water flow should be stopped when the chiller shuts off. This will conserve energy and prevent refrigerant from migrating to the condenser. Moisture in the air can condense on the cooler surfaces of the un-insulated condenser barrel if flow is present when the chiller is idle.

Water Side Economizer Cycle Operation

Water side economizers are commonly used for ASHRAE 90.1 compliance and energy savings. This system utilizes a heat exchanger external to the chiller when cold cooling tower water is available to provide cooling. The most common system uses a heat exchanger in conjunction with the chiller’s evaporator.

The BAS contractor will need to provide controls for the heat exchanger including isolation valves and temperature control. The BAS contractor will also need to control the isolation valves for the chiller. It is important to use slow-acting type valves to prevent rapid changes in system flows. Changeover from economizer cooling to mechanical cooling requires one of the methods previously mentioned to maintain suitable condenser head pressure. Contact your local Daikin Applied representative for more information on this application.

Heat Recovery Chillers

HSC heat recovery chillers control based upon the chilled water leaving temperature. The cooling load determines compressor loading and unloading, the same as in a conventional chiller. A heat recovery control algorithm is identical to a conventional cooling-only chiller. The amount of heat recovered from the condenser shall depend on the cooling load. If cooling load on the chiller drops, the hot water temperature supplied by the heat recovery condenser would also drop.

Alternately, the 3-way cooling tower bypass valve, controlled by heating water inlet temperature to the recovery bundle of the condenser, can be used to manipulate the cooling tower water loop. Based on the signal the 3-way valve gets from the hot inlet water temperature sensor, it will bypass sufficient water around the tower to increase the condenser water loop temperature at the inlet. The supply water temperature to the heating load will “float” depending on actual chiller load. This 3-way valve along with the necessary controls and wiring are

supplied by the customer (see Figure 5).

It is important to confirm if the chiller can maintain operation in heat recovery mode during part load operation if the supply temperature to the heat recovery condenser is held constant by the tower bypass valve. Also, it is important to size the cooling tower for full condenser heat rejection if the heating load requirements are expected to vary, especially during summer months. Contact a Daikin Applied representative to review specific heat recovery applications.

Figure 5: Heat Recovery System Schematic

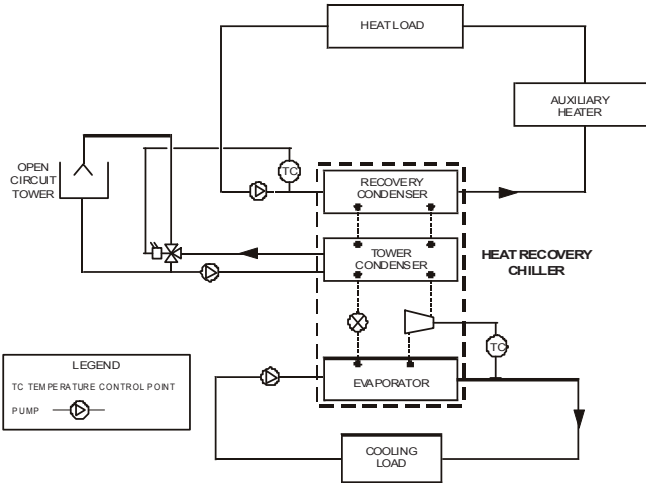

Relief Valves

As a safety precaution and to meet code requirements, each chiller is equipped with pressure relief valves located on the condenser and evaporator for the purpose of relieving excessive refrigerant pressure (caused by equipment malfunction, fire, etc.) to the atmosphere.

Table 5: Centrifugal B-vintage Relief Valve Data

	Evaporator	Condenser	Oil Sump
Location	Top	Top	Top
Setting (psi) *	200	225	200
Discharge Capacity (lb/min air)	75.5	84.4	5
Qty	1 for 12' shells 2 for 16' shells	2 for 12' shells 4 for 16' shells	1 for 079-126 models
Connection Size	1.0-inch NPT		3/8-inch NPT

* Custom chillers and Templifier models may have design specific relief valve settings.

Most codes require that relief valves be vented to the outside of a building. Relief piping connections to the relief valves must have flexible connectors.

CAUTION

Units are shipped with refrigerant valves closed to isolate the refrigerant in the unit condenser. Valves must remain closed until startup by the factory service technician.

Remove plastic shipping plugs (if installed) from the inside of the valves prior to making pipe connections. Whenever vent piping is installed, the lines must be in accordance with local code requirements; where local codes do not apply, the latest issue of ANSI/ASHRAE Standard 15 code recommendations must be followed.

Condenser Relief Valves

In order to ensure proper installation, it is important to know how the three-way relief valve functions. One valve remains active at all times and the second valve acts as a standby. When the stem of the three-way valve is pushed into the valve completely, the valve is in "Front Seated Position" and all refrigerant will flow through the back outlet port. When the stem of the three-way valve is pulled back completely, the valve is in "Back Seated Position" and all refrigerant will flow through the front outlet port, as shown in Figure 6.

Figure 6: Condenser Three-Way Relief Valve

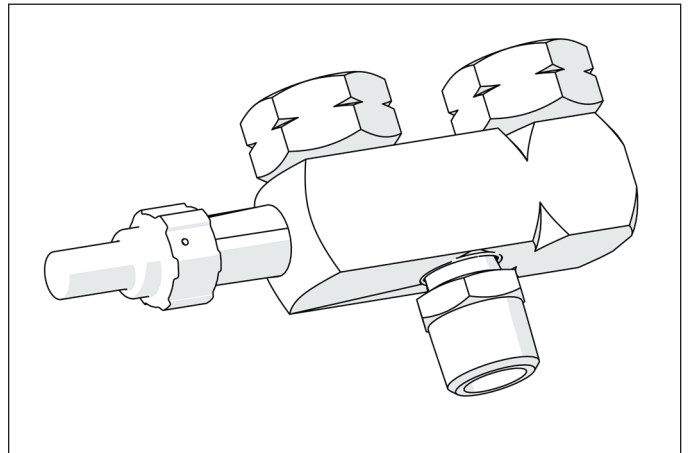

Figure 7: Three-Way Valve, Front Seated Position

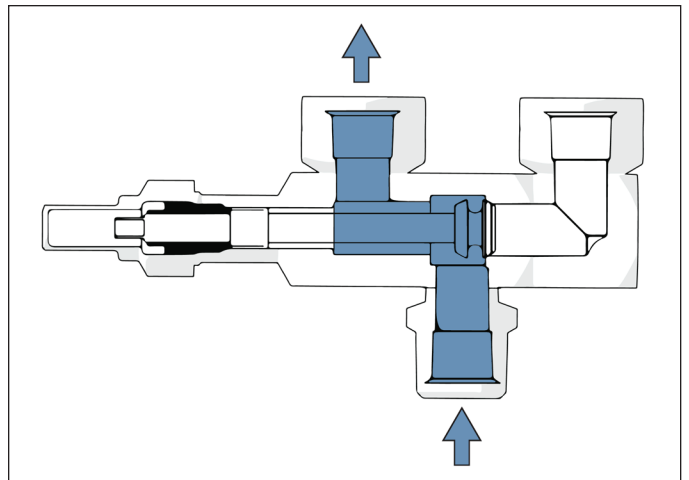
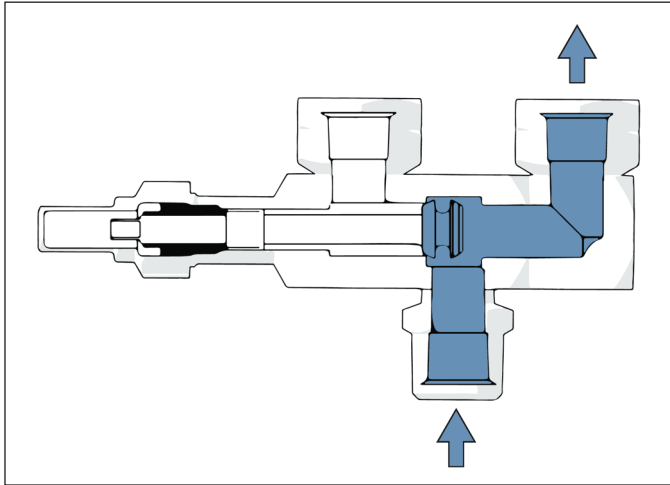

Figure 8: Three Way Valve, Back Seated Position



When the valve stem is not pushed forward or pulled back completely, the valve is in "Mid Position," as shown in

CAUTION

Do not operate the system with the three-way valve stem in the Mid Position.

Figure 9: Three-Way Valve, Mid Position

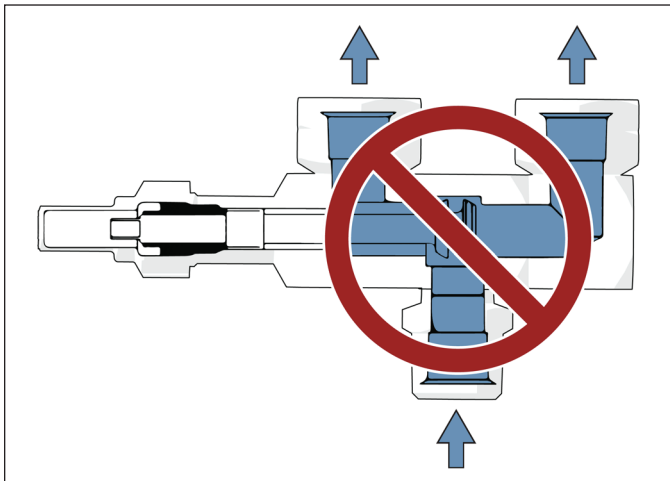

Oil Coolers

WARNING

This unit contains POE lubricants that must be handled carefully and the proper protective equipment (gloves, eye protection, etc.) must be used when handling POE lubricant. Failure to do so can result in personal injury. POE must not come into contact with any surface or material that might be harmed by POE, including certain polymers (e.g. PVC/CPVC and polycarbonate piping).

Daikin Applied centrifugal chillers (models 079-126) have a factory-mounted, water-cooled oil cooler, temperature-controlled water regulating valve and solenoid valve per

compressor. Centrifugal single compressor cooling water connections are located near the compressor and are shown on the specific unit certified drawings.

Field water piping to the inlet and outlet connections must be installed according to good piping practices and include stop valves to isolate the cooler for servicing. A cleanable filter (40 mesh maximum), and drain valve or plug must also be field-installed. The water supply for the oil cooler should be from the chilled water circuit or from a clean, independent source, no warmer than 80°F (27°C), such as city water. When using chilled water, it is important that the water pressure drop across the evaporator is greater than the pressure drop across the oil cooler or insufficient oil cooler flow will result. If the pressure drop across the evaporator is less than the oil cooler, the oil cooler must be piped across the chilled water pump, provided that its pressure drop is sufficient. The water flow through the oil cooler will be adjusted by the unit's regulating valve so that the temperature of oil supplied to the compressor bearings (leaving the oil cooler) is between 95°F and 105°F (35°C and 40°C).

Table 6: Oil Cooler Data

Compressor Model Size	Hot Side POE Lube	Cold Side Water Options to achieve 100 °F Outlet Temp			
079 - 087 - Connection Size: 0.75 inches					
Flow, gpm	9.9	11.9	2.9	2.0	1.54
Inlet Temp, °F	118.0	80.0	65.0	55.0	45.0
Outlet Temp, °F	100.0	87.3	94.5	98.3	101.4
Pressure Drop, psi	-	4.3	0.3	0.14	0.09
100 - 126 - Connection Size: 1.0 inches					
Flow, gpm	15.8	21.9	5.1	3.5	2.7
Inlet Temp, °F	120.0	80.0	65.0	55.0	45.0
Outlet Temp, °F	100.0	87.0	95.0	99.0	102.3
Pressure Drop, psi	-	3.78	0.23	0.11	0.07

Compressors using chilled water for oil cooling will often start with warm "chilled water" in the system until the chilled water loop temperature is pulled down. Data given above includes that condition. As can be seen, with cooling water in the 45°F to 65°F (7°C to 18°C) range, considerably less water will be used, and the pressure drop will be greatly reduced.

When supplied with city water, the oil piping must discharge through a trap into an open drain to prevent draining the cooler by siphoning. The city water can also be used for cooling tower makeup by discharging it into the tower sump from a point above the highest possible water level.

NOTE: Particular attention must be paid to chillers with variable chilled water flow through the evaporator. The pressure drop available at low flow rates can be insufficient to supply the oil cooler with enough water. In this case an auxiliary booster pump can be used or city water employed.

Figure 10: Oil Cooler Piping Across Chilled Water Pump - Models WSC/HSC/TSC 079-126

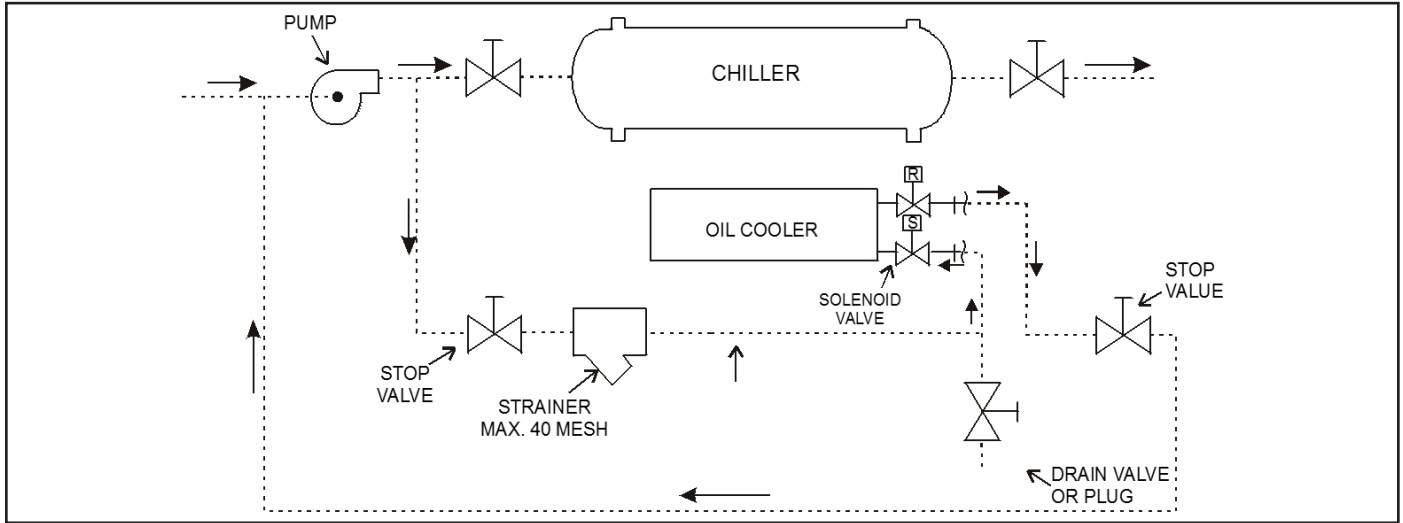

NOTE: Dotted lines indicate field supplied piping and components.

Figure 11: Oil Cooler Piping With City Water - Models WSC/HSC/TSC 079-126

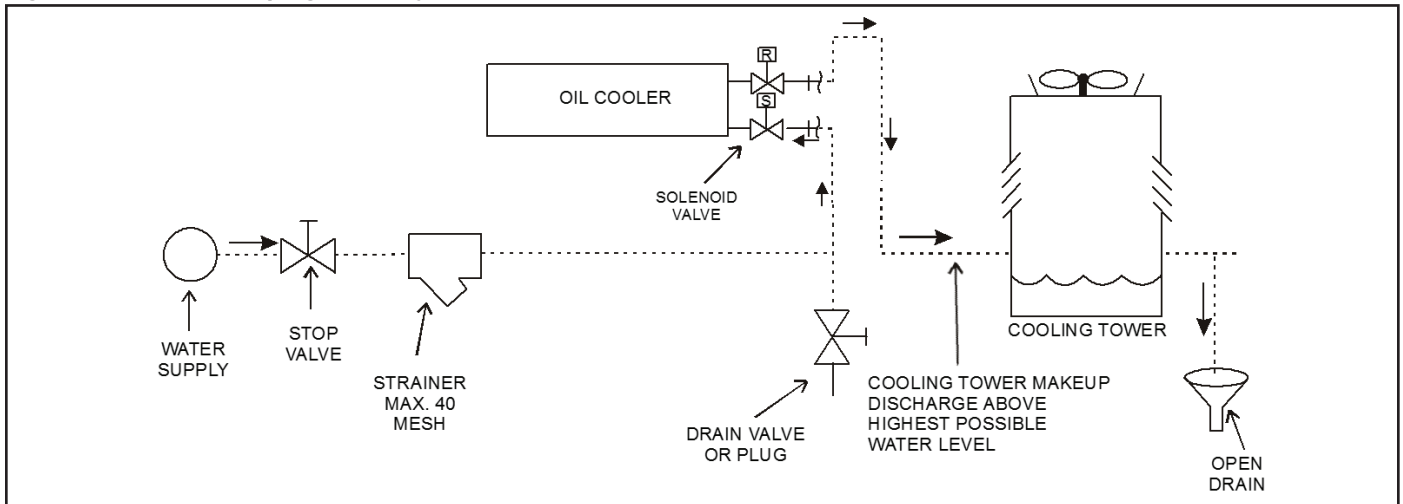

Oil Heater

The oil sump is equipped with an immersion heater that is installed in a tube so that it can be removed without disturbing the oil.

Figure 12: Oil Cooler - Oil Sump Water Connections Models 079-126

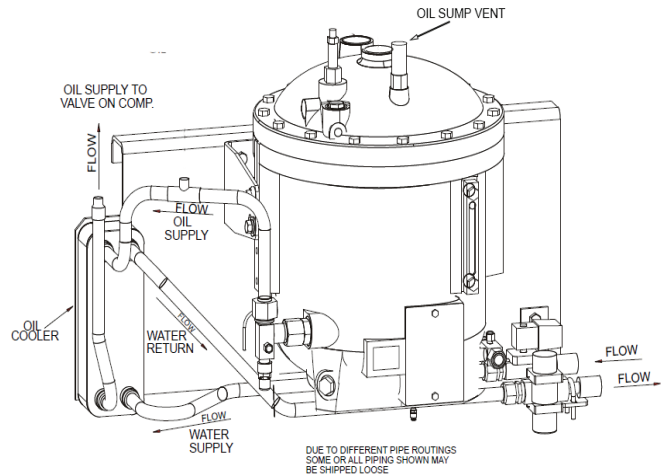

Figure 13: Typical Refrigerant Flow Diagram - Models WSC/TSC 079-126

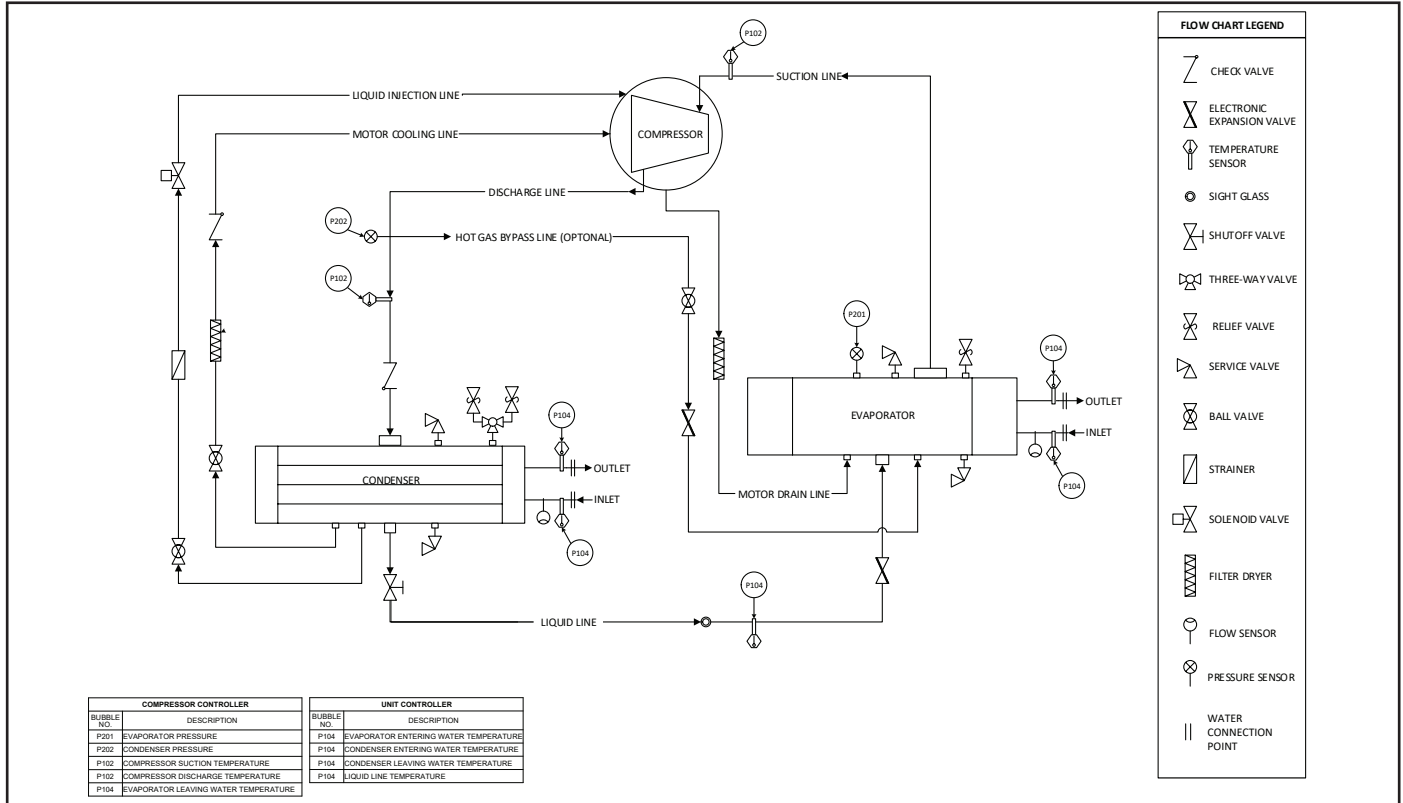
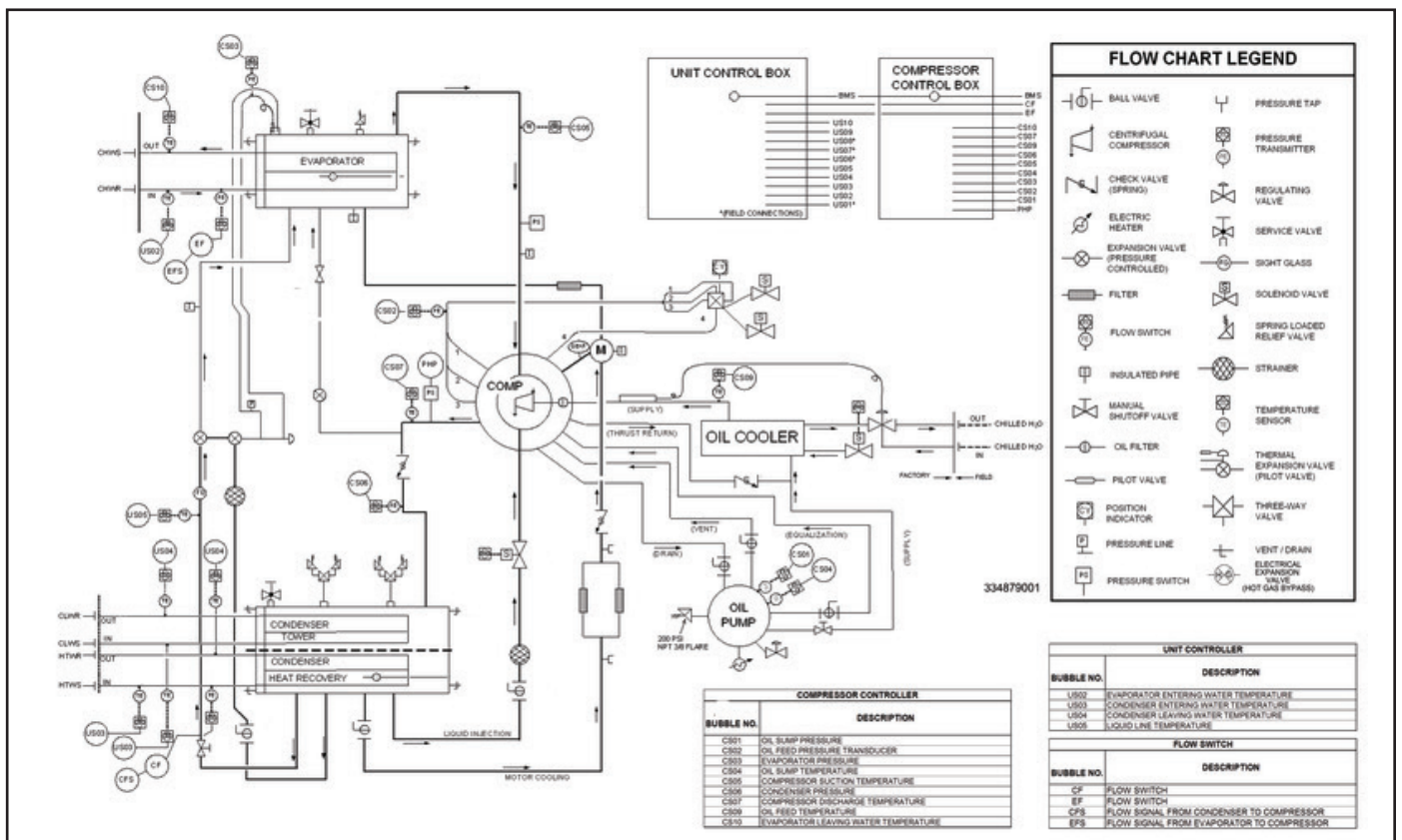

Figure 14: Typical Refrigerant Flow Diagram - Models HSC 079-126



Field Wiring

Unit Mounted Starters

The standard power wiring connection to single compressor centrifugal chillers is single-point. Power conduit entry will be at the top of the unit power panel, see [Figure 15](#) for general reference as power entry cover plate location will vary by unit configuration. Wiring diagrams are provided with the chiller.

Correction capacitors are not necessary since VFDs inherently maintain high power factors and can cause harmful electrical resonance in the system.

Only copper wiring and lugs should be used for power wiring connections. Wiring ampacity based on 75°C conductor rating should be used for voltages less than 2000V; 90°C or 105°C rated conductors should be used for voltages greater than 2000V. Refer to the unit nameplate and the Daikin Tools selection report for the correct electrical ratings.

⚠ DANGER

Qualified and licensed electricians must perform wiring. Disconnect, lockout, and tag all electrical power sources to the unit before servicing the compressor and/or removing refrigerant. An electrical shock hazard exists that can cause severe injury or death.

Figure 15: Unit Mounted Power Connection Point

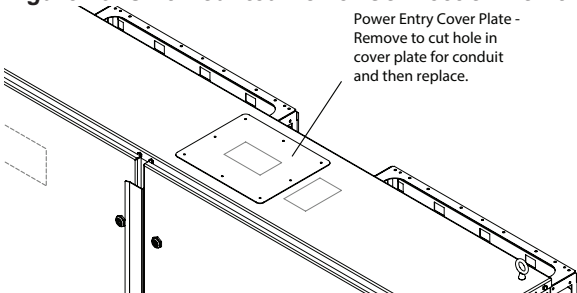

NOTE: Wiring, fuse, and wire size must be in accordance with the National Electric Code (NEC). The voltage to these units must be within $\pm 10\%$ of nameplate voltage (415V units must have voltage within -13% and +6% of nameplate voltage) and the voltage unbalance between phases must not exceed 2%. Since a 2% voltage unbalance will cause a current unbalance of 6 to 10 times the voltage unbalance per the NEMA MG-1 Standard, it is most important that the unbalance between phases be kept at a minimum.

⚠ CAUTION

A compressor should only be brought up to speed if proper sequence and rotation have been confirmed. Do not make final connections to motor terminals until wiring has been checked and approved by a Daikin Applied service technician. Serious damage can result if the compressor starts in the wrong direction and would not be covered by product warranty.

The compressor is covered under UL 984 by which its terminal box is determined, per clause 8.1, by the end-use product standard, which is UL 1995. If exceeding 1000V with controls, Daikin Applied refers contractor to employ UL508A.

The NFPA 70 (NEC) provides information pertaining to 'minimum wire-bending space.' Wiring to a terminal box will vary depending on voltage, see the current version of Daikin Applied Installation, Operation and Maintenance Manuals, IOMM 1158 (ATL, SS, WD) or IOMM 1250 (VFD).

Full Metering

Remote mounted wye-delta, solid state, and across-the-line starters require field wiring to activate the full power metering display on the chiller's operator interface panel. The wiring is from the control board in the starter to the compressor controller.

Figure 16: Wiring for Optional Display

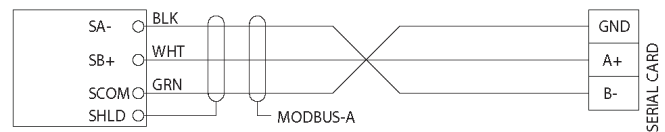

NOTE:

- The serial card location is in the lower-center of the compressor controller located in the chiller control panel.
- The control board is located in the starter.
- The connections are (-) to (-), (+) to (+) and SCOM to GND with a shield connection on the starter terminal board.
- Cable is Belden 9841 or equal (120 OHM characteristic impedance)

Control Power Wiring Options

The control circuit on the Daikin Applied centrifugal packaged chiller is designed for 115-volts to the control panel. Control power can be supplied from three different sources:

1. If the unit is supplied with a factory-mounted starter or VFD, the control circuit power supply is factory-wired from a transformer located in the starter or VFD.
2. A freestanding starter or VFD furnished by Daikin Applied, or by the customer to Daikin Applied specifications, will have a control transformer(s) in it and requires field wiring to terminals in the compressor terminal box.
3. Power can be supplied from a separate circuit and fused at 25 amps inductive load. The control circuit disconnect switch must be tagged to prevent current interruption. Other than for service work, the switch is to remain on at all times in order to keep oil heaters operative and prevent refrigerant from diluting in oil.

⚠ DANGER

If a separate control power source is used, the following must be done to avoid severe personal injury or death from electrical shock: 1) Place a notice on the unit that multiple power sources are connected to the unit; and 2) Place a notice on the main control power disconnects that another source of power to the unit exists.

In the event a transformer supplies control voltage, it must be rated at 3 KVA, with an inrush rating of 12 KVA minimum at 80% power factor and 95% secondary voltage. For control wire sizing, refer to NEC Articles 215 and 310. In the absence of complete information to permit calculations, the voltage drop should be physically measured.

Table 7: Control Power Line Sizing - 115 to 220 Vac

Maximum Length, ft (m)	Minimum Wire Size (AWG)
0 (0) to 50 (15.2)	12

NOTE:

1. Maximum length is the distance a conductor will traverse between the control power source and the unit control panel.
2. Panel terminal connectors will accommodate up to number 10 AWG wire. Larger conductors will require an intermediate junction box.

The Unit On/Off switch located in the Unit Control Panel should be turned to the "Off" position any time compressor operation is not desired.

Surge Capacitors

Surge capacitors are an option for some unit-mounted, low voltage starter configurations (not for solid state starters or VFDs) to protect compressor motors from electrical damage resulting from high voltage spikes. If ordered, the capacitors are factory-mounted and wired in the starter enclosure.

Building Automation Systems (BAS)

All MicroTech® controllers with an open protocol platform are capable of BAS communications, providing easy integration and comprehensive monitoring, control, and two-way data exchange with open standard protocols such as LonTalk®, Modbus® or BACnet®.

Daikin Applied unit controllers strictly conform to the interoperability guidelines of the LonMark® Interoperability Association and BACnet® International. They have received LonMark® certification with optional LONWORKS® communication module.

Protocol Options

The following protocol options are available:

- BACnet® MS/TP
- BACnet® IP
- BACnet® Ethernet
- LONWORKS®
- Modbus® RTU

The BAS communication module can be ordered with the chiller and factory-mounted or can be field-mounted at any time after the chiller unit is installed. Connection to the chiller for all BAS protocols will be at the unit controller.

If an interface module was ordered, the appropriate BAS interface installation manual was shipped with the unit. If necessary, contact your local Daikin Applied sales office for an additional manual or download from www.DaikinApplied.com.

Use with On-Site Generators

Centrifugal chillers using oil may be run with On-Site Generators when utility power is lost. The HVAC system and chiller have to be disconnected from the power grid and connected to the generator power. Then enable the HVAC system while on the generator.

Generator Sizing

Natural gas and diesel generators are sensitive to the peak current loads of the chiller. Use the electric data on the Starters supplied with the chiller or the chiller performance rating sheet – obtained from the Daikin Applied sales office – for generator sizing purposes. The reference data will show the RLA and LRA, which is for each compressor. It is important to size the generator to handle the LRA for the compressor motor for starting.

⚠ WARNING

Generator must be sized by an electrical engineer familiar with generator applications.

Transfer Back to Grid Power

If the generator to power grid has synchronous power switch capability then it can be done at any time. Usually this switch does not exist so the switch is done by shutting down the HVAC system including the chiller that is running on the generator. Then switch the power for the HVAC system to the power from the grid and then turning the HVAC system back on including the Chiller.

Field Wiring, Controls & Starters

NOTES for Following Wiring Diagram:

1. Compressor motor starters are either factory mounted and wired, or shipped separate for field mounting and wiring. If provided by others, starters must comply with the current version of Daikin Applied specification 735999901. All line and load side power conductors must be copper with ampacity based on 75°C conductor rating. Exception: For equipment rated over 2000 volts, 90°C or 105°C rated conductors shall be used.
2. If starters are freestanding, then field wiring between the starter and the control panel is required. Minimum wire size for 115 Vac to 220 Vac is 12 gauge for a maximum length of 50 feet. If greater than 50 feet, refer to Daikin Applied for recommended wire size minimum. Wire size for 24 Vac is 18 gauge. All wiring to be installed as NEC Class 1 wiring system. All 24 Vac wiring must be run in separate conduit from 115 Vac to 220 Vac wiring. Main power wiring between starter and motor terminal is factory-installed when units are supplied with unit-mounted starters. Wiring of free-standing starter must be wired in accordance with NEC and connection to compressor motor terminals must be made with copper wire and copper lugs only. Control wiring on free-standing starters is terminated on a terminal strip in the motor terminal box (not the unit control panel). Wiring from the unit control panel to the motor terminal is done in the factory.
3. For optional sensor wiring, see unit control diagram. It is recommended that DC wires be run separately from 115 Vac to 220 Vac wiring.
4. Customer furnished 24 or 230 Vac power for alarm relay coil can be connected between UTB1 terminals 84 power and 86 neutral of the control panel. For normally open contacts, wire between 82 & 86. For normally closed contacts, wire between 83 & 86. The alarm is operator programmable. The maximum rating of the alarm relay coil is 25 VA.
5. Remote on/off control of unit can be accomplished by installing a set of dry contacts between terminals 27 and 21 and remove wire jumper.
6. Evaporator and condenser flow switches are required. Thermal dispersion flow switches are installed and wired from the factory as standard.
7. Customer supplied 24 to 230 Vac, 20 amp power for optional evaporator and condenser water pump control power and tower fans is supplied to unit control terminals (UTBI) 85 power / 86 neutral, PE equipment ground.
8. Optional customer supplied 24 to 220 Vac, 25 VA maximum coil rated chilled water pump relay (EP 1 & 2) may be wired as shown. This option will cycle the chilled water pump in response to chiller demand.
9. The condenser water pump must cycle with the unit. A customer supplied 24-220 Vac 25 VA maximum coil rated condenser water pump relay (CP1 & 2) is to be wired as shown. Units with free cooling must have condenser water above 60°F before starting.
10. Optional customer supplied 24-220 Vac, 25 VA maximum coil rated cooling tower fan relays (C1 - C2 standard, C3 - C4 optional) may be wired as shown. This option will cycle the cooling tower fans in order to maintain unit head pressure.
11. For VFD, Wye-Delta, and solid state starters connected to six (6) terminal motors. The conductors between the starter and motor carry phase current and selection shall be based on 58 percent of the motor rated load amperes (RLA). Wiring of free-standing starter must be in accordance with the NEC and connection to the compressor motor terminals shall be made with copper wire and copper lugs only. Main power wiring between the starter and motor terminals is factory-installed when chillers are supplied with unit-mounted starters.
12. Motor current has three selectable options as follows: 0-5V/0- 10V/0- 20mA by build in HMI. Compressor VFD speed has two selectable options as follows:0-10V/4 - 20mA.
13. Optional open protocol BAS interfaces. The locations and interconnection requirements for the various standard protocols are found in their respective installation manuals, obtainable from the local Daikin Applied sales office and also shipped with each unit: Modbus IM 743 LonWorks IM 735 BACnet IM 906
14. The "Full Metering" or "Amps Only Metering" capability will require some field wiring when free-standing starters are used. Wiring will depend on chiller and starter type. Consult the local Daikin Applied sales office for information on specific selections.

Figure 18: Compressor Control Box

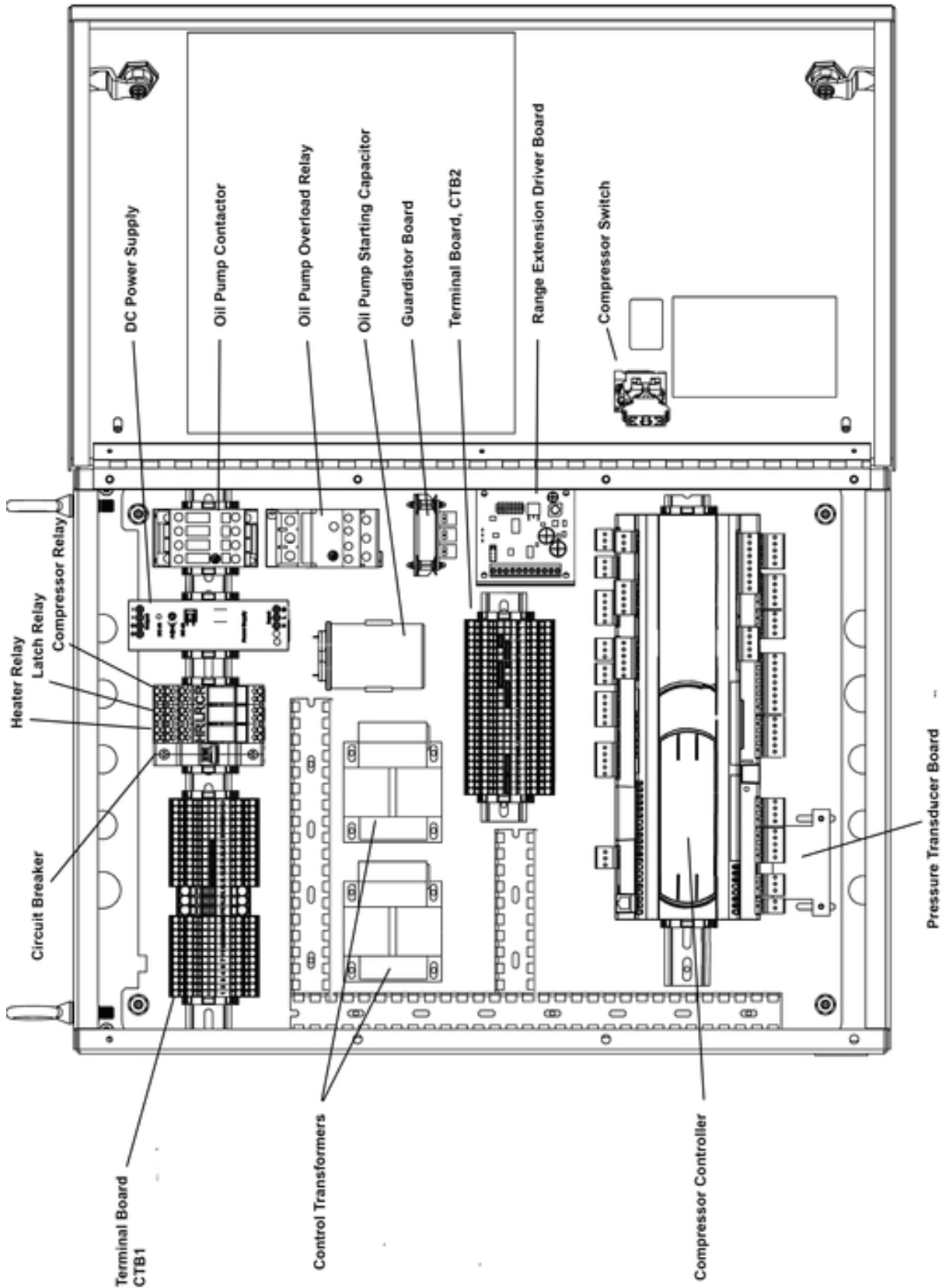
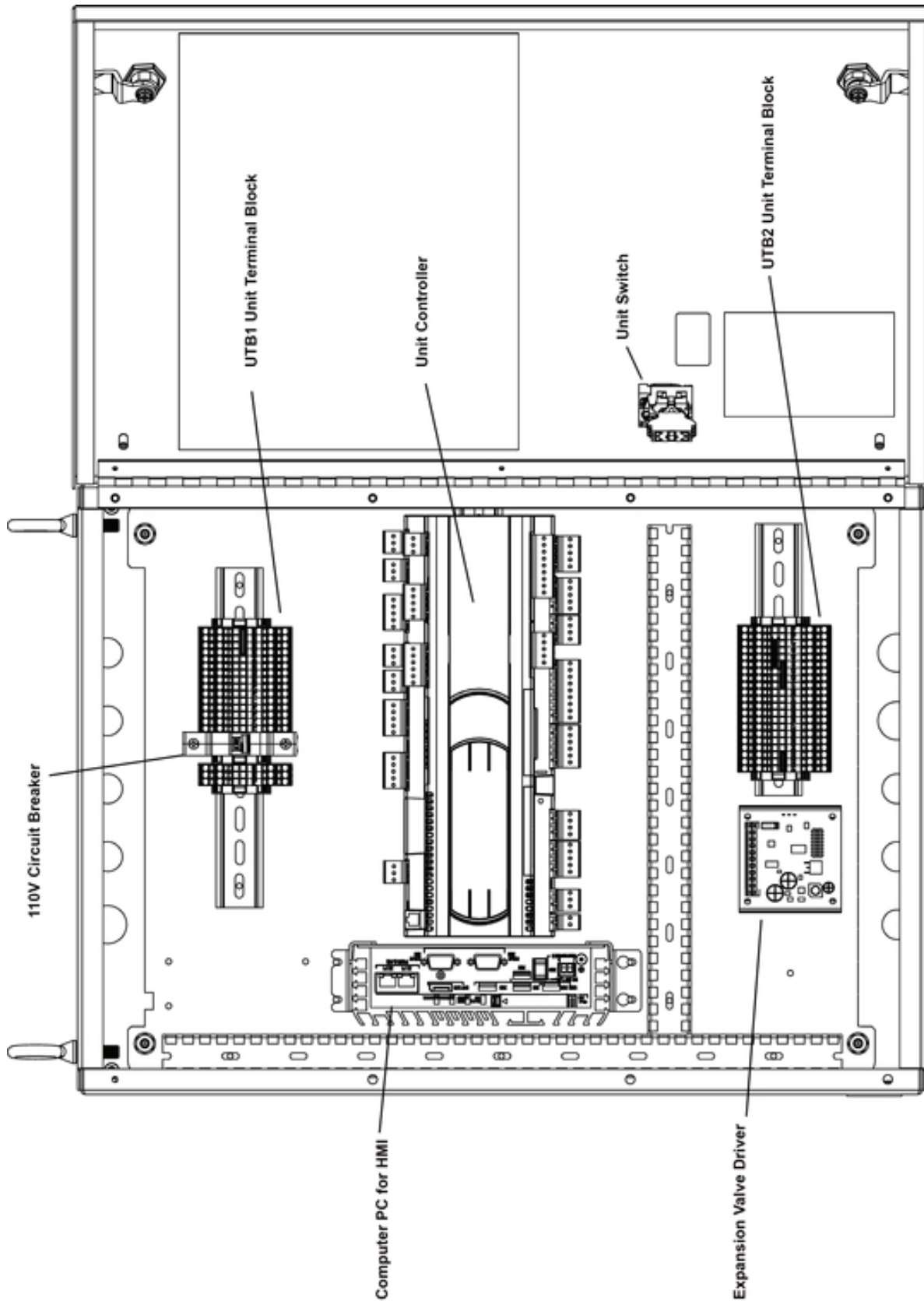

Figure 19: Unit Control Box



Long Term Storage

This information applies to new units being stored waiting for startup or to existing units that may be inoperative for a long period.

The chiller must be stored indoors and protected from any damage or corrosion. A Daikin Applied service representative must perform an inspection and leak test of unit on minimum quarterly schedule, to be paid by the owner or contractor. Daikin Applied will not be responsible for any refrigerant loss during the storage time or repairs to unit during period of storage, or while moving the unit from original location to storage facility and back to new installation location. Refer to “Table 1: Equipment Room Guidelines” on page 8.

The following tasks must be performed:

1. As discussed above, the first and foremost task is to leak test the unit when it is in its final resting place. If any leaks exist, repair them immediately. After the unit is stored, perform a periodic leak test.
2. It is possible that the unit could be bumped, hit or otherwise damaged while in storage; so in addition to leak testing, a visual overall inspection should be done.
3. If there is concern about the possibilities of damage and loss of charge during storage, the customer can pay to have the charge removed and stored in recovery cylinders. If this is done, pressurize it to about 20 psi with nitrogen. Monitor and maintain the pressure. Install a pressure gauge that can easily be read or tie in a remote alarm that can be monitored if pressure reduces. This is desirable if the unit is stored with refrigerant or with a nitrogen holding charge.
4. If the unit has been shipped and not yet installed, keep it pumped down (as shipped from the factory) and close all refrigerant valves. Keep oil sump valves closed to avoid refrigerant migration to the oil sump. Over a long term, the refrigerant will migrate to the oil tank and displace the oil. The oil will spill over in to the evaporator through the vent line and when the unit is powered up and the heaters turned on, the refrigerant will boil out and the sump will be empty.
5. Clean and dry the unit and look for any chipped paint. Touch up as required to prevent rust.
6. If the storage area is subject to a high humidity, consider a shrink wrap or water resistant covering of some sort. Desiccants must be placed inside electrical panels and starters (mounted or shipped loose) and be renewed as recommended by manufacturer.
7. The Human Machine Interface (HMI), which is shipped loose, should be secured in a dry area.

8. Regardless of the temperature of the storage area, make sure all vessel tubes are drained and blown dry to prevent the minerals in the standing water, plus oxygen present, causing tube pitting. This includes the oil cooler and water piping.
9. Restart by Daikin Applied service technicians will be required and paid to Daikin Applied by the owner or contractor. It is prudent to take photos when the unit is stored to show that the conditions of storage have been met. Also document all inspection reports and abnormal conditions found. If the unit has been in operation, the run-time hours and number of starts must be documented prior to storage, along with the date the unit was taken out of operation. The extended warranty coverage can be suspended during the storage period-not to exceed 30 months. The remaining warranty time will restart once unit is reinstalled and officially re-commissioned by Daikin Applied.

CAUTION

If the temperature of where the chiller is located is expected to exceed 113°F (45°C), then the refrigerant must be removed.

For additional tasks required, contact Daikin Applied service.

Retrofit Knockdown

Various knockdown arrangements are available as options and are ideal for retrofit applications with tight installation clearances.

Bolt-Together Construction - Type A

Chillers are built and shipped completely assembled with bolt-together construction on major components for field disassembly and reassembly on the job site.

Figure 20: Bolt-Together Construction Option - Representative Schematic

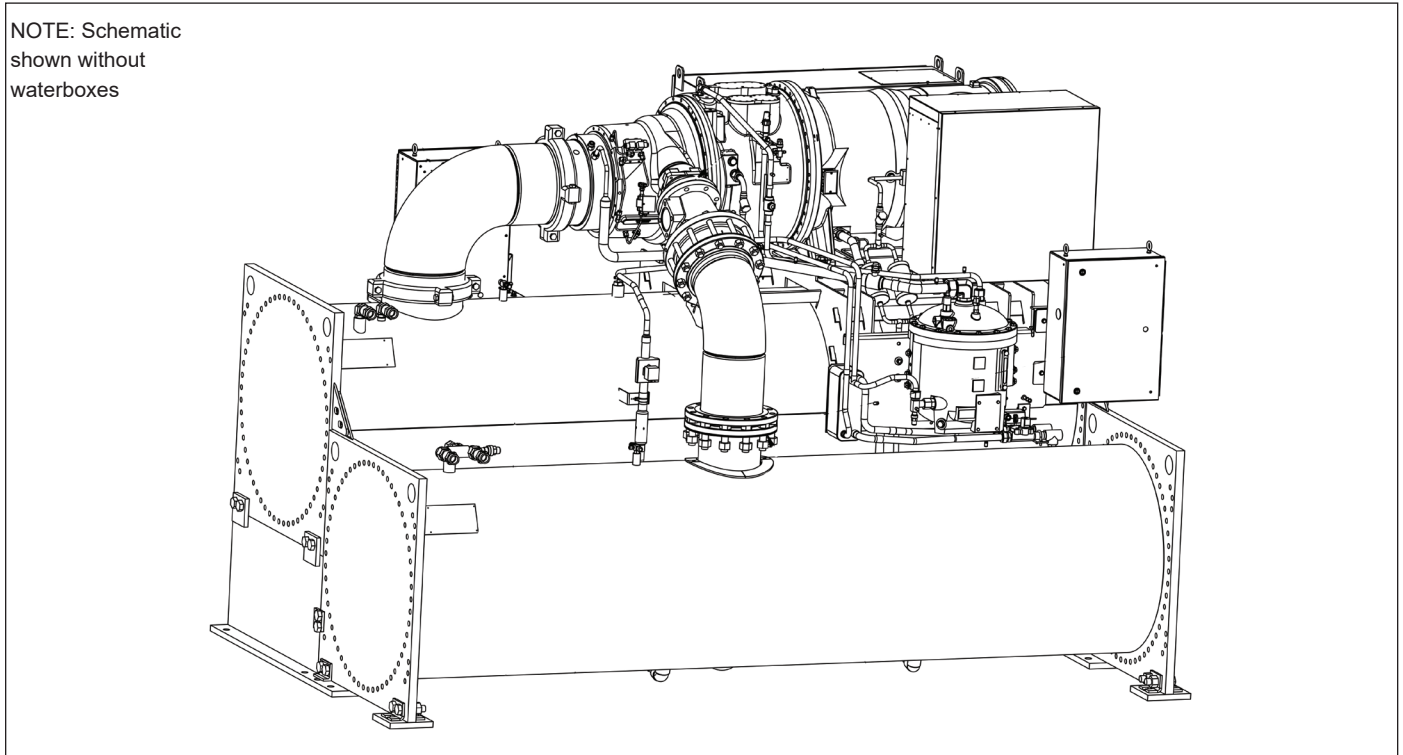

Scope:

- Site disassembly and reassembly must be supervised or completed by Daikin Applied service personnel.
- Unit is fully tested at the factory prior to shipment.
- The chiller is shipped completely assembled with the full refrigerant charge, which must be recovered before breaking any refrigerant connection.
- The refrigerant charge must be removed from the unit if the vessels are to be separated. Exert the proper precautions before attempting any disassembly, assume the condenser isolation valves may have leaked and that any component of the chiller may be pressurized with refrigerant.
- Suction and discharge lines have bolt-on flanges.
- Motor cooling line is brazed at mechanical connections.
- Blockoff plates are required to cover any refrigerant connection left open for extended periods of time. Contact Daikin Applied service to obtain these parts.
- Check that no power is being applied to the unit. Before disconnecting any wire, it is prudent to label its function and connection point to facilitate re-connection.
- Unit ships with vessel and/or head insulation, if ordered.
- Unit ships with replacement refrigerant gaskets and O-rings, stick-on wire ties, and touch-up paint. Some insulation repair and touch-up painting may be required.

⚠ CAUTION

Standard torque specs must be followed when re-installing bolts. Contact Daikin Applied service for this information.

Partial Disassembly Construction - Type B

Compressor(s), power box(es), and control box are removed at the factory and shipped on separate skids; combined vessel stack is shipped together as a sub-assembly.

Figure 21: Partial Disassembly Construction Option - Representative Schematic

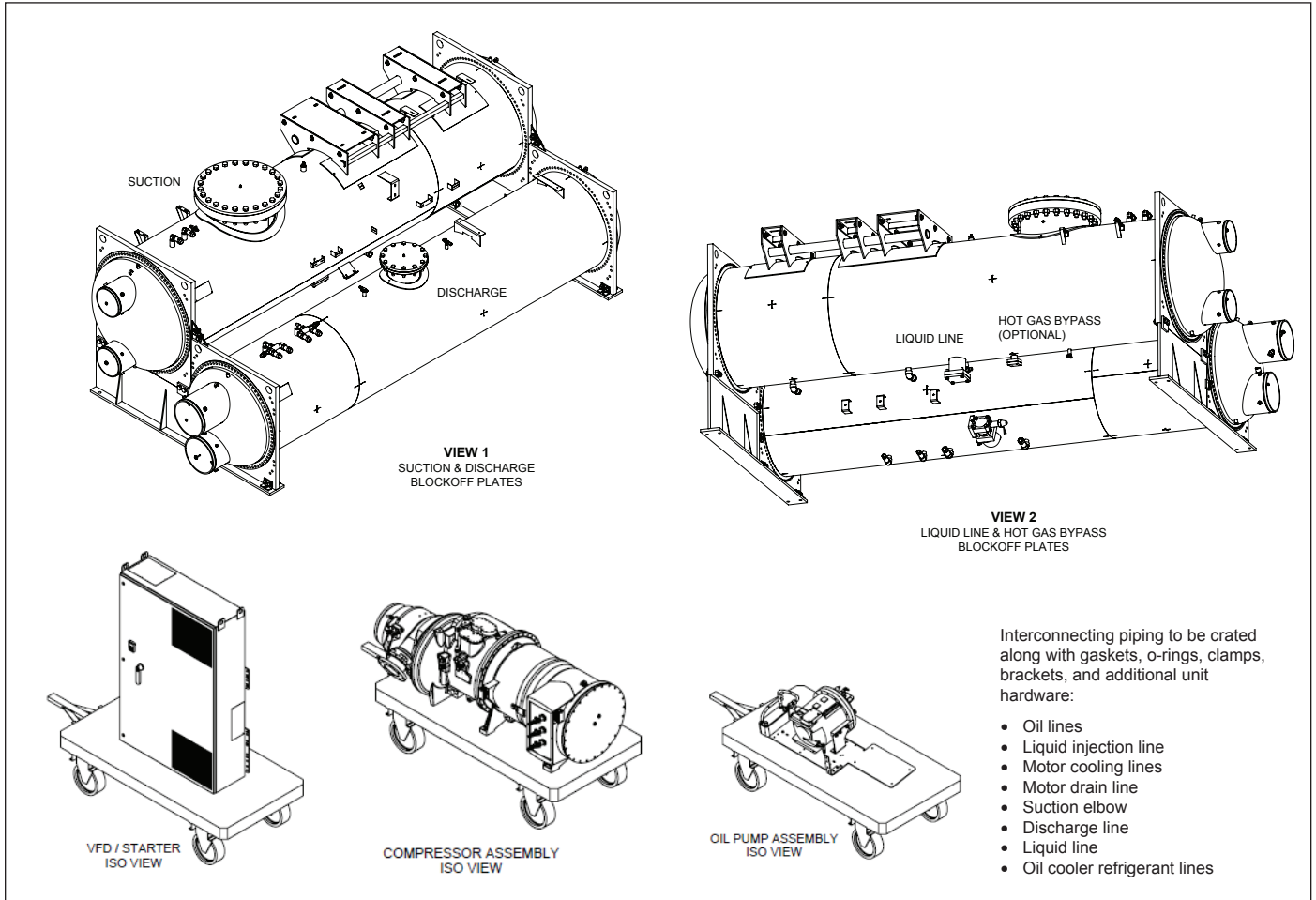

Scope:

- Site reassembly must be supervised or completed by Daikin Applied service personnel. Cost for unit reassembly and supervision by Daikin Applied service is not included in the purchase price of the equipment. Contact Daikin Applied service for pricing.
- Unit is fully tested at the factory prior to disassembly and shipment.
- All associated piping and wiring remain attached, if possible. Suction and discharge lines have bolt-on flanges and, if possible, remain attached. If the stack size or weight dictates further disassembly, the vessels can be separated by disconnecting any interconnecting wiring and tubing and then unbolting them.
- Refrigerant will not be shipped with the chiller and must be procured by others. Compressor(s) and vessels receive an inert gas holding charge that must be released prior to attempting to open any connection.

- All free piping ends are capped, blockoffs will cover all compressor and vessel openings.
- Unit ships with vessel and/or head insulation, if ordered.
- Unit ships with replacement refrigerant gaskets and O-rings, stick-on wire ties, and touch-up paint.

CAUTION

Standard torque specs must be followed when re-installing bolts. Contact Daikin Applied service for this information.

WARNING

Remove compressor, piping or vessel holding charge through the Schrader valve in the block off plates before attempting to loosen any fittings on them. Failure to do so can cause severe bodily injury.

Unit Knockdown Dimensions

NOTE: Drawings, dimensional values, and other information may change depending on options or configurations selected. Refer to the as-built submittal drawings provided by a Daikin Applied sales representative for configuration-specific details.

Figure 22: Unit Dimensional Diagram for Typical WSC/HSC/TSC Knockdown

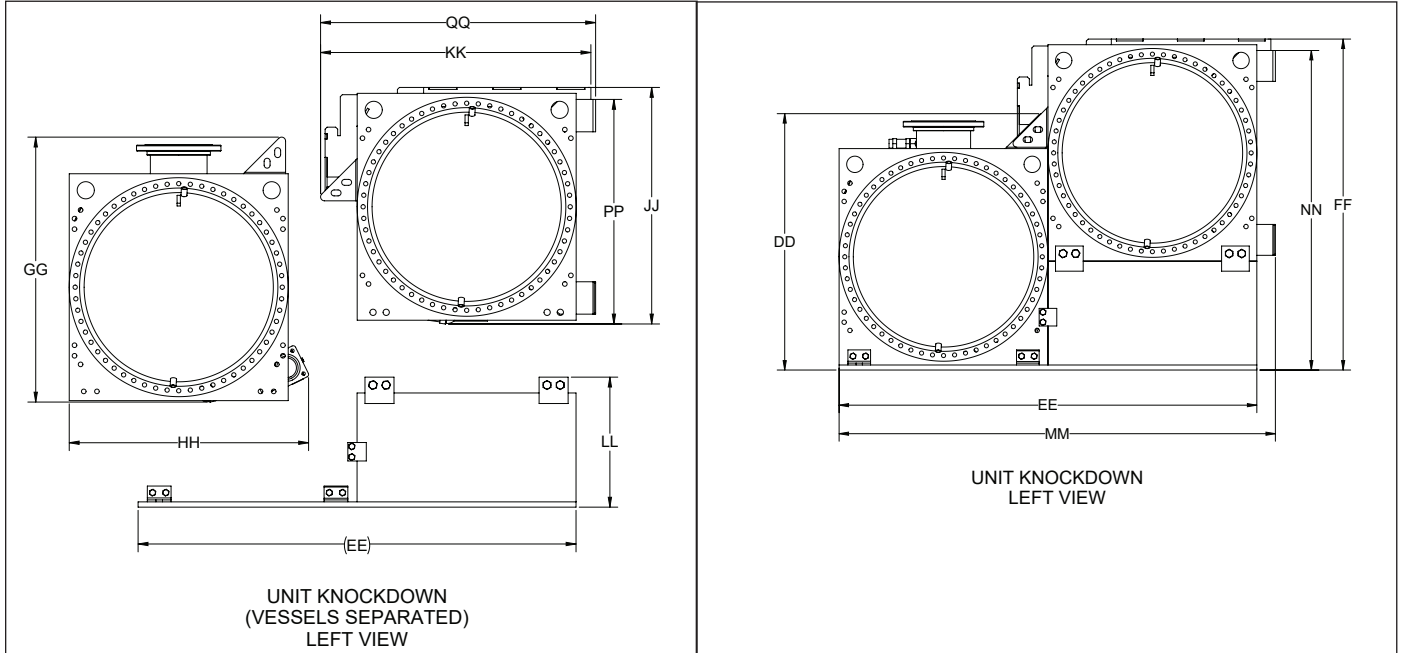

NOTES:

1. IF NO DIMENSION IS LISTED IN THE 'MOUNTED STARTER TABLE' IT IS BECAUSE THE STARTER BRACKETS DO NOT EXCEED THE ENVELOPE DIMENSIONED IN THE 'ALL UNITS TABLE'.
2. DIMENSIONS FF, JJ, NN, AND PP DO NOT TAKE INTO ACCOUNT ANY VALVES SUCH AS RELIEF VALVES THAT MAY INCREASE THE ENVELOPE.

EXPLANATION OF KNOCKDOWN DIMENSIONS:

- DD HEIGHT (BOTTOM OF FOOT TO TOP OF COND TIE PLATE)
- EE OVERALL WIDTH - UNIT (OUTSIDE EDGE OF COND TUBESHEET TO OUTSIDE EDGE OF EVAP TUBESHEET)
- FF OVERALL HEIGHT - UNIT (BOTTOM OF FOOT TO TOP EVAP, EITHER EVAP TUBESHEET OR COMPR BRACKET)
- GG HEIGHT - COND (BOTTOM OF COND, EITHER COND TUBESHEET OR PIPING, TO TOP OF COND TIE PLATE)
- HH WIDTH - COND (OUTSIDE EDGE OF COND TUBESHEET TO OUTSIDE EDGE OF SHUTOFF VALVE)
- JJ HEIGHT - EVAP (BOTTOM OF MOTOR DRAIN LINE TO TOP OF EVAP, EITHER EVAP TUBESHEET OR COMPR BRACKET)
- KK WIDTH - EVAP (OUTSIDE EDGE OF EVAP TIE PLATE TO OUTSIDE EDGE OF EVAP TUBESHEET OR COMPR BRACKET)
- LL HEIGHT - TUBESHEET SUPPORT (BOTTOM OF FOOT TO TOP OF TIE BRACKET)
- MM OVERALL WIDTH - UNIT (OUTSIDE EDGE OF COND TUBESHEET TO OUTSIDE FACE OF STARTER BRACKET)
- NN OVERALL HEIGHT - UNIT (BOTTOM OF FOOT TO TOP EDGE OF TOP STARTER BRACKET ON EVAP)
- PP HEIGHT - EVAP (BOTTOM OF MOTOR DRAIN LINE TO TOP EDGE OF TOP STARTER BRACKET)
- QQ WIDTH - EVAP (OUTSIDE EDGE OF EVAP TIE PLATE TO OUTSIDE FACE OF STARTER BRACKET)

Table 8: Centrifugal Single Compressor Knockdown Dimensions

Label	Dimensions - inches (mm)						
	079/087			087			100
	E2612/C2212	E2612/C2612	E3012/C2612	E3012/C3012	E3612/C3012	E3612/C3612	E3612/C3012
DD	35.9 (912.)	40.9 (1039)	40.9 (1039)	44.9 (1141)	43.9 (1115)	50.9 (1293)	43.9 (1115)
EE	49.0 (1245)	51.5 (1308)	56.2 (1429)	59.8 (1520)	77.0 (1955)	83.0 (2108)	77.0 (1955)
FF	52.8 (1245)	58.4 (1308)	63.3 (1429)	67.6 (1520)	69.4 (1955)	78.4 (2108)	65.7 (1955)
GG	35.9 (913.)	37.9 (963.)	40.4 (1026)	44.2 (1124)	43.2 (1099)	50.2 (1275)	43.2 (1099)
HH	30.6 (777.)	36.2 (921.)	36.2 (921.)	42.3 (1075)	42.3 (1075)	46.5 (1183)	40.7 (1034)
JJ	33.3 (846.)	33.3 (846.)	38.4 (976.)	38.4 (976.)	44.4 (1127)	44.4 (1127)	44.8 (1138)
KK	37.0 (941.)	37.0 (941.)	42.4 (1077)	42.4 (1077)	48.4 (1230)	48.4 (1230)	48.4 (1230)
LL	23.8 (604.)	29.4 (747.)	29.1 (739.)	33.4 (848.)	28.7 (731.)	37.7 (959.)	24.6 (625.)
MM	49.9 (1269)	52.4 (1332)	56.2 (1429)	59.8 (1520)	77.0 (1955)	83.0 (2108)	80.6 (2049)
NN	53.5 (1360)	59.1 (1503)	56.2 (1429)	59.8 (1520)	77.0 (1955)	83.0 (2108)	77.0 (1955)
PP	34.0 (865.)	34.0 (865.)	38.4 (976.)	38.4 (976.)	44.4 (1127)	44.4 (1127)	44.8 (1138)
QQ	38.0 (965.)	38.0 (965.)	42.4 (1077)	42.4 (1077)	48.4 (1230)	48.4 (1230)	52.1 (1324)

Label	100/113/126				
	E3612/C3612	E4212/C3612	E4216/C3616	E4212/C4212	E4216/C4216
DD	50.9 (1293)	50.9 (1293)	50.9 (1293)	57.9 (1471)	57.9 (1471)
EE	83.0 (2108)	89 (2260)	89.0 (2260)	95 (2413)	95 (2413)
FF	65.7 (2108)	71.0 (2260)	71.0 (2260)	73.1 (2413)	73.1 (2413)
GG	50.2 (1275)	50.2 (1275)	50.2 (1275)	56.9 (1446)	56.9 (1446)
HH	45.3 (1152)	45.3 (1152)	45.3 (1152)	49.5 (1259)	49.5 (1259)
JJ	44.8 (1138)	52.4 (1331)	52.4 (1331)	52.4 (1331)	52.4 (1331)
KK	48.4 (1230)	54.4 (1382)	54.4 (1382)	54.4 (1382)	54.4 (1382)
LL	24.6 (625.)	21.7 (553.)	21.7 (553.)	23.9 (607.)	23.9 (607.)
MM	86.6 (2201)	91.9 (2334)	91.9 (2334)	97.9 (2486)	97.9 (2486)
NN	65.7 (1670)	71.0 (1803)	71.0 (1803)	73.1 (1858)	73.1 (1858)
PP	44.8 (1138)	52.4 (1331)	52.4 (1331)	52.4 (1331)	52.4 (1331)
QQ	52.1 (1324)	57.1 (1452)	57.1 (1452)	57.1 (1452)	57.1 (1452)

Table 9: Vessel Component Weights

Component	Vessel Dry Weight		2 Pass Standard Waterbox		Marine Waterboxes		Dished Return Head	
	lbs	kg	lbs	kg	lbs	kg	lbs	kg
E2612	3880	1760	143	65	985	447	75	34
E3012	4669	2118	245	111	1400	635	132	60
E3612	6769	3070	328	149	2238	1015	131	59
E4212	8922	4047	450	204	3176	1441	210	95
E4216	11591	5258	450	204	3176	1441	210	95
E4816	14888	6753	648	294	4471	2028	269	122
C2212	3071	1393	167	76	704	319	54	24
C2612	5010	2272	185	84	1032	468	75	34
C3012	7210	3270	300	136	1454	660	132	60
C3612	9801	4446	329	149	2290	1039	131	59
C3616	13118	5950	329	149	2290	1039	131	59
C4212	10267	4657	531	241	3358	1523	210	95
C4216	17845	8094	531	241	3358	1523	210	95

*Consult submittal drawings for job specific information. Referenced component weights based on largest unit with standard tube configuration. Waterbox weights reflect standard flanged 2-pass connections. Heat recovery waterboxes not reflected in this table.

Knockdown Rigging/Lifting Guidelines

To properly rig or lift separated assemblies and components, consult a licensed, certified rigging specialist.

- Lifting holes located in the tubesheets should be used to attach chain hoists for moving connected vessel stacks or individual evaporator/condenser assemblies. Rolling dollies supporting the full vessel width may also be used under the tubesheets on each end.
- Lift the VFD / Starter by attaching chain hoists to the lifting brackets located at the top corners of the cabinet. Rolling dollies supporting the full cabinet width may also be used.
- Lift the oil pump assembly by attaching eye bolts in the 2 holes on the top of the oil pump and then connect the chain hoists. Eye bolts are not provided. Rolling dollies may also be used.
- Lift dished waterbox head assemblies by attaching chain hoists to the lifting lugs on the head. The location of the lifting lug will vary depending on size of the waterbox and nozzle configuration. Rolling dollies may also be used.
- Lift marine waterbox head assemblies by wrapping lifting straps around the body of the waterbox. Rolling dollies may also be used.
- Lift the compressor by wrapping lifting straps around the body of the assembly, see [Figure 25](#). Rolling dollies supporting the full length of the compressor may also be used.

Note component weights and dimensions are listed in [Table 8](#) to [Table 10](#).

Figure 23: Vessel Stack Lifting/Rigging Setup

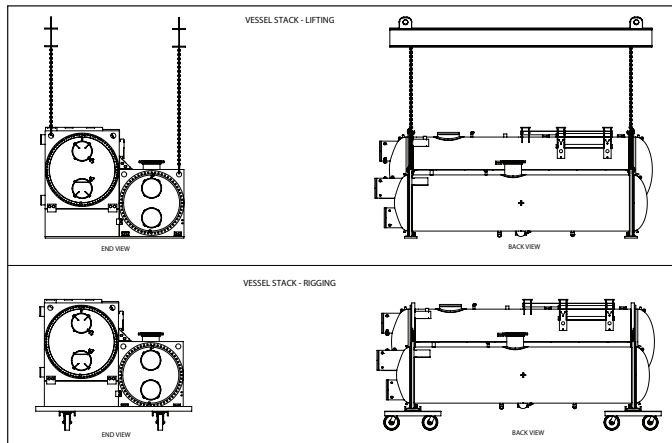

NOTE: The spreader bars in [Figure 23](#) and [Figure 24](#) are representations only and may not reflect the appearance of the actual spreader bars needed.

Figure 24: Component Lifting Setup

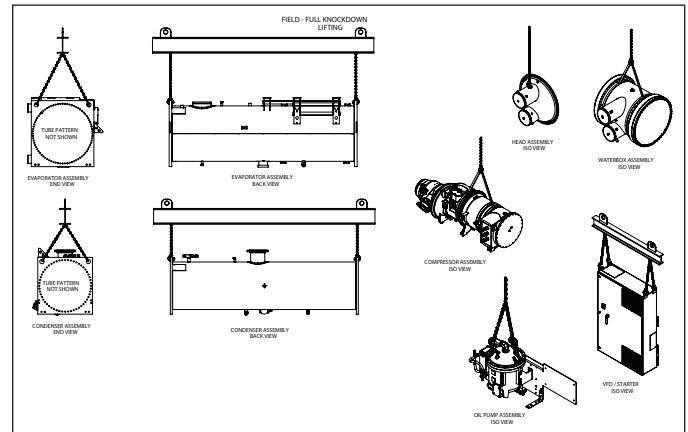

⚠ WARNING

Improper rigging, lifting, or moving of a unit can result in property damage, severe personal injury or death. Follow rigging and moving instructions carefully. Daikin Applied is not a licensed nor certified rigging specialist. It is the customer's responsibility to consult a certified rigging contractor to rig, lift, and move components and subcomponents properly and safely.

Figure 25: Compressor Lifting Setup - Closeup

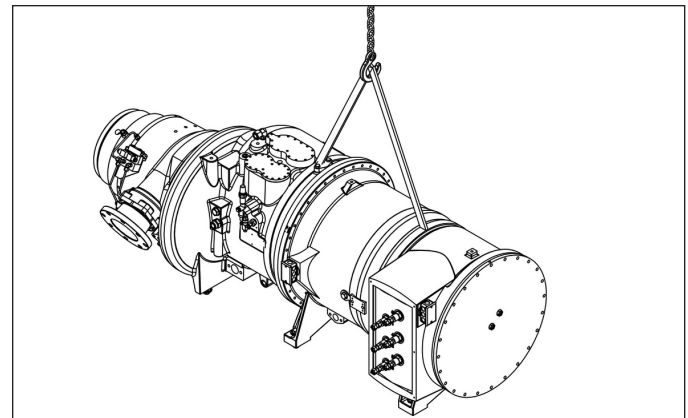

Compressor Dimensions

NOTE: Drawings, dimensional values, and other information may change depending on options or configurations selected. Refer to the as-built submittal drawings provided by a Daikin Applied sales representative for configuration-specific details.

The compressor dimensions vary by model. All dimensions and weights per compressor are listed in [Table 10](#).

Figure 26: Representation - Compressor Dimensions

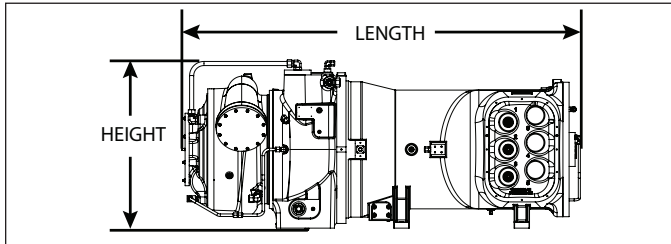

Table 10: Dimensions for WSC/TSC/HSC Compressors

Model	Length in (mm)	Width in (mm)	Height in (mm)	Weight lb (kg)
WSC079	64.9 (1648)	32.3 (821)	25.1 (638)	3200 (1451)
WSC087	64.9 (1648)	32.3 (821)	25.1 (638)	3200 (1451)
WSC100	87.5 (2224)	43.2 (1097)	31.0 (788)	6000 (2721)
WSC113	87.5 (2224)	43.2 (1097)	31.0 (788)	6000 (2721)
WSC126	87.5 (2224)	43.2 (1097)	31.0 (788)	6000 (2721)

Compressor Removal and Re-Attachment Instructions

Follow the steps listed to remove and re-attach the compressor.

Compressor Removal Preparation

1. Prior to detaching or unsweating any connections, verify there is no pressure or charge in the lines.
2. Close shut-off valve at condenser liquid line outlet.
3. Close all other related shut-off valves.
4. Remove the oil eductor line, providing a blockoff cap at compressor and evaporator connection points.
5. Remove the liquid injection line, providing a blockoff cap at the compressor gear housing and condenser connection points; see [Figure 27](#).
6. Remove motor cooling line. Provide blockoff caps at the compressor and condenser connection points. Cover filter drier opening to prevent debris from entering.
7. Remove the motor drain lines, providing block off caps at the compressor motor housing and evaporator connections., The 1/4" vent line will need to be braced in a minimum of 2 places to prevent damage.

8. Remove oiler cooler lines, providing block off caps at the compressor gear housing connections; see [Figure 27](#).
9. Remove hot gas bypass line, providing blockoff caps at the discharge nozzle and evaporator connection points. Care must be taken when brazing or removing lines to not apply excessive heat to valve seats; use cooling wraps at all times on valve components.
10. Disconnect power leads from starter.
11. Loosen and remove bolts on the top side of the compressor discharge nozzle (see [Figure 28](#), flag #5).
12. Loosen and remove bolts at flange on condenser and remove discharge piping.
13. Cover openings with blockoffs to prevent foreign objects entering.

Figure 27: Oil Cooler Line Identifications

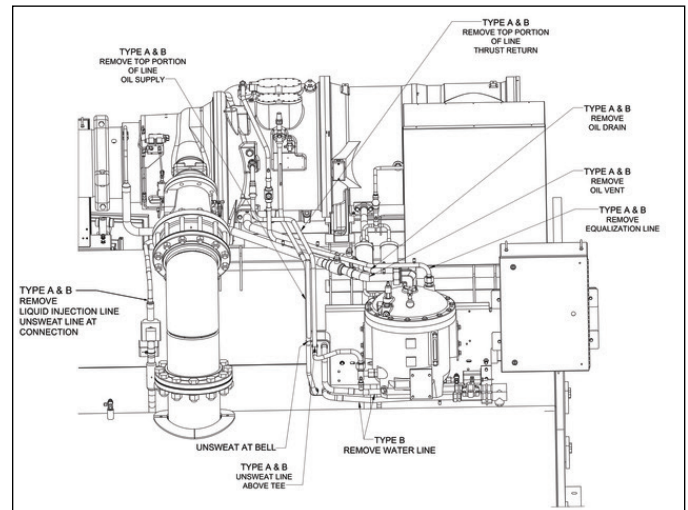

NOTE: Graphic is representative. Line locations may vary by unit configuration.

Compressor Removal

1. Loosen and remove bolts/screws on either side of the suction elbow (see [Figure 28](#)).
2. Loosen the (8) bolts from the compressor's bottom mounting feet (see [Figure 28](#)).
3. Use lifting straps on the compressor assembly [Figure 25](#) to rig compressor for removal. Compressor dimensions and weights are given in [Table 10](#).

Separating Vessel Stacks

After removing compressor and associated lines for Type A knockdown, the liquid line connecting the evaporator and condenser as well as the oil sump would need to be removed to separate the vessels. [Figure 29](#) illustrates the mechanical break points for the liquid line where blockoffs must be provided on each vessel. [Figure 30](#) shows the various connections for oil sump assemblies that need block off caps.

Figure 28: Compressor Removal / Re-Attachment

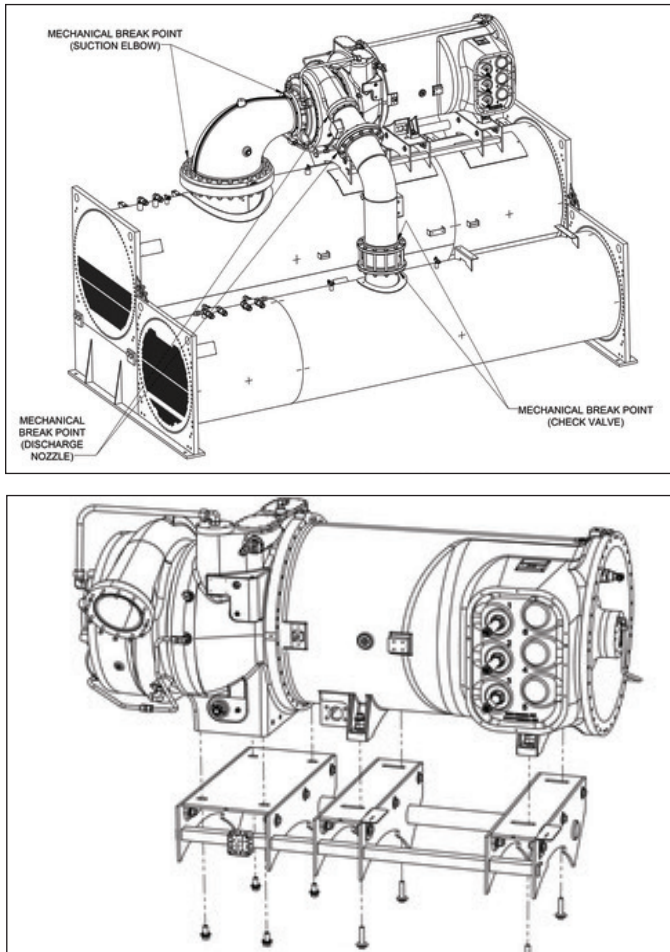

Unit Reassembly

The level of disassembly required for unit installation will be varied. For all steps, use new refrigerant gaskets and o-rings provided.

1. If the vessels were separated, rejoin them as a first step.
2. The compressor and its suction and discharge piping should be installed on the vessel stack before any other lines are attached. Mounting bolts and additional hardware are shipped as a kit. Leave the mounting bolts loose until the suction and discharge lines are in place and aligned. Before tightening the couplings, position the suction and discharge piping so that the compressor can be aligned properly. When piping is in the correct position, secure the compressor mounting bolts and proceed with installing the couplings using a thin coating of lubricant.
3. Install the liquid line
4. Install the oil sump and oil cooler lines
5. Install the motor cooling lines
6. Install the liquid injection line
7. Install hot gas bypass line if applicable
8. Install motor drain lines
9. Install oil eductor line
10. Install the electrical wiring and sensor connections as shown in [Figure 31](#) to [Figure 33](#).
11. Re-attach all associated power wiring & Ethernet cable.
12. Pull vacuum at evaporator and compressor to 300 microns and perform a standing hold to verify no moisture or leaks - do not allow rise of 300 microns within 1 hour.
13. Charge unit with required amounts of refrigerant and oil and perform refrigerant leak check to ensure all connections and fittings are securely fastened.
14. Insulate evaporator, compressor, suction line, and other required areas as necessary.

Figure 29: Liquid Line Assembly - Representative Placement Shown

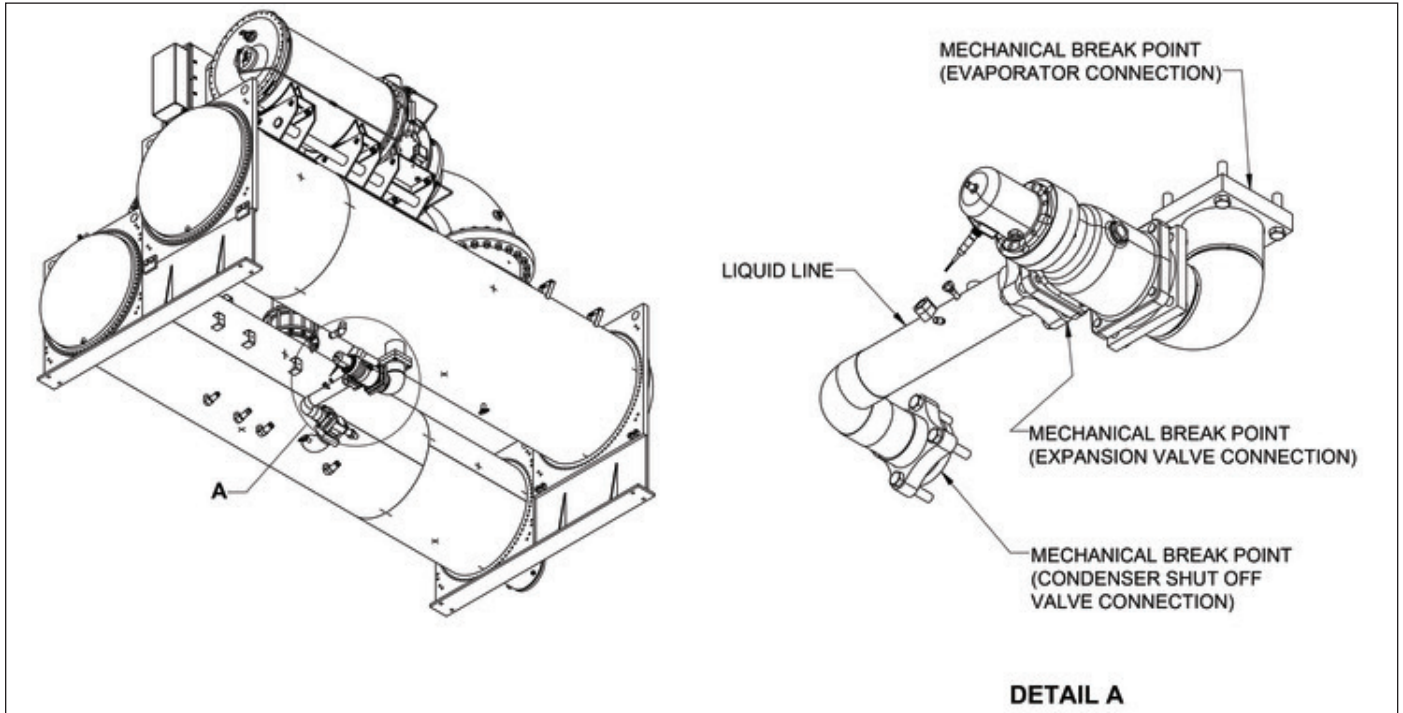

Figure 30: Oil Sump/Oil Cooler Assembly - Models WSC/TSC/HSC 079-126

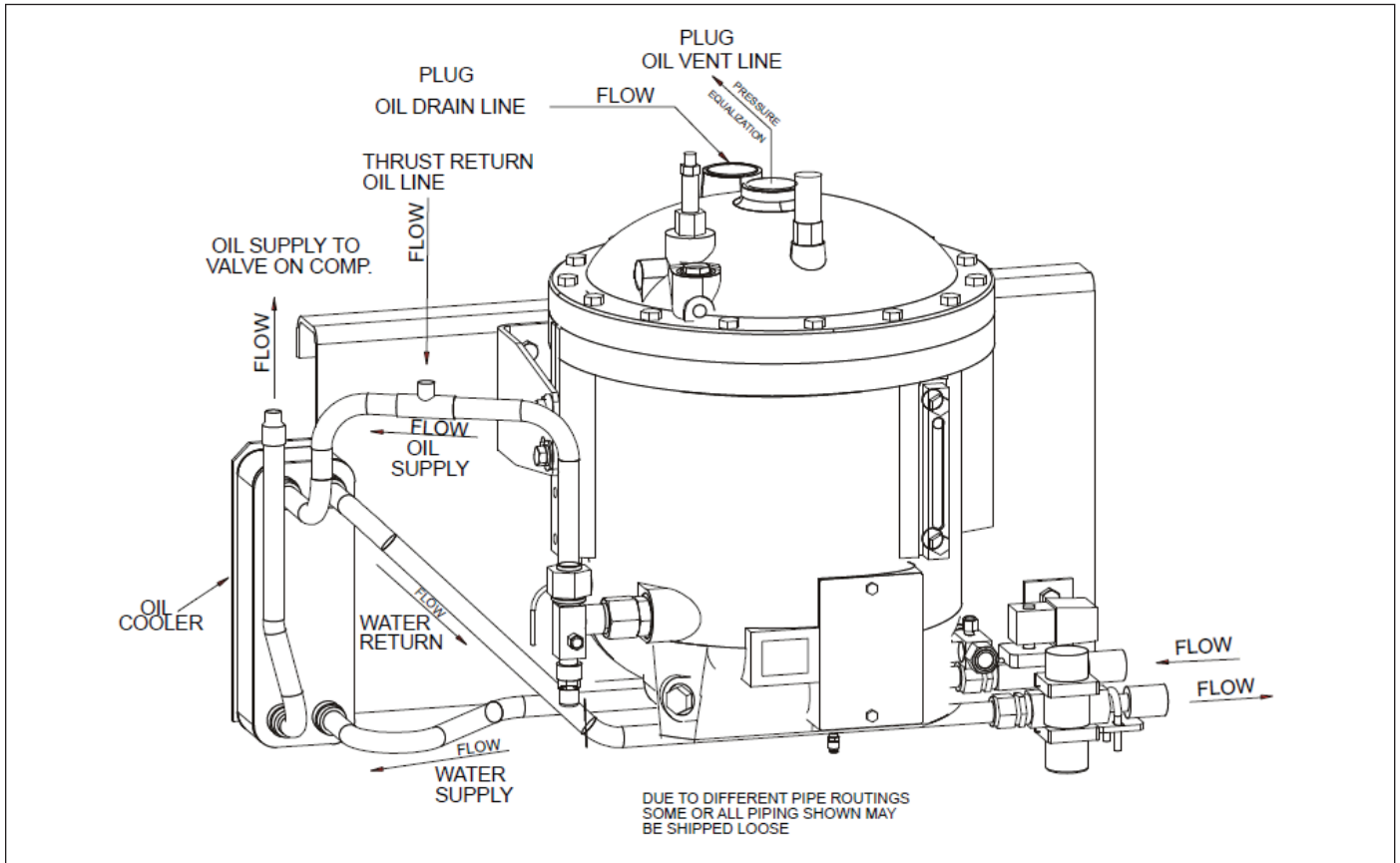

Figure 31: Compressor Control Panel Electrical and Sensor Connections

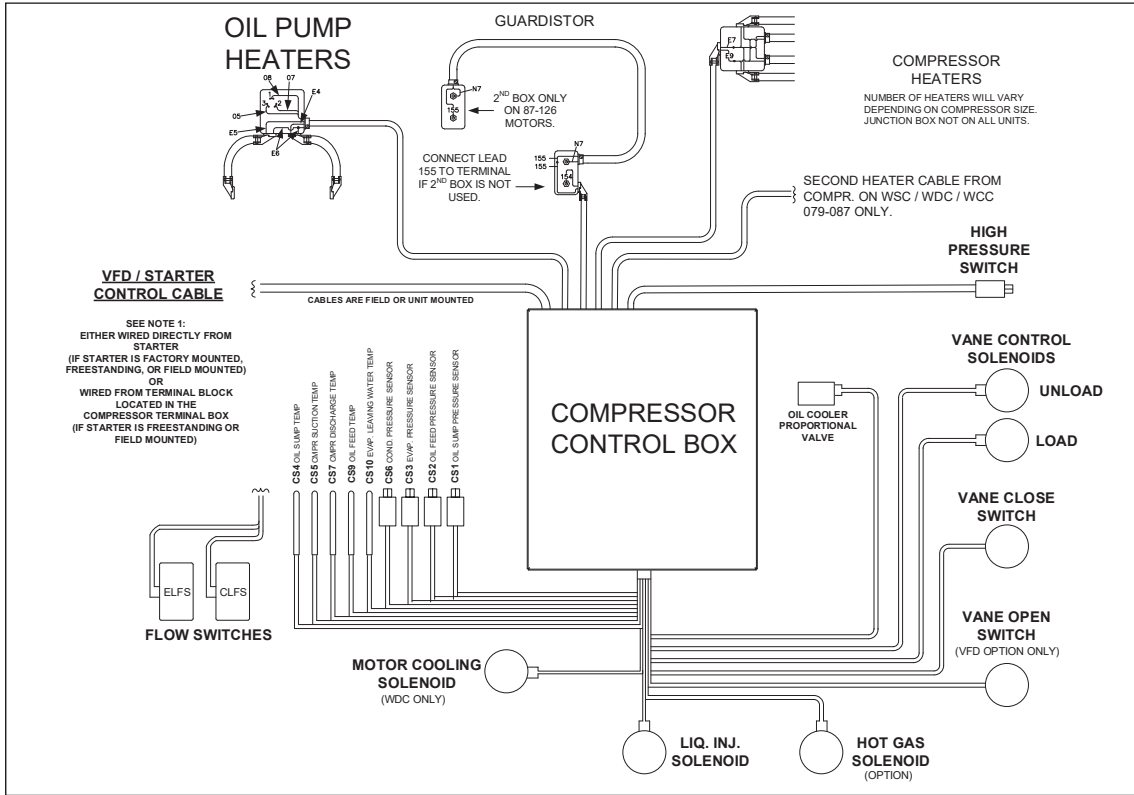

Figure 32: Unit Controller Electrical and Sensor Connections

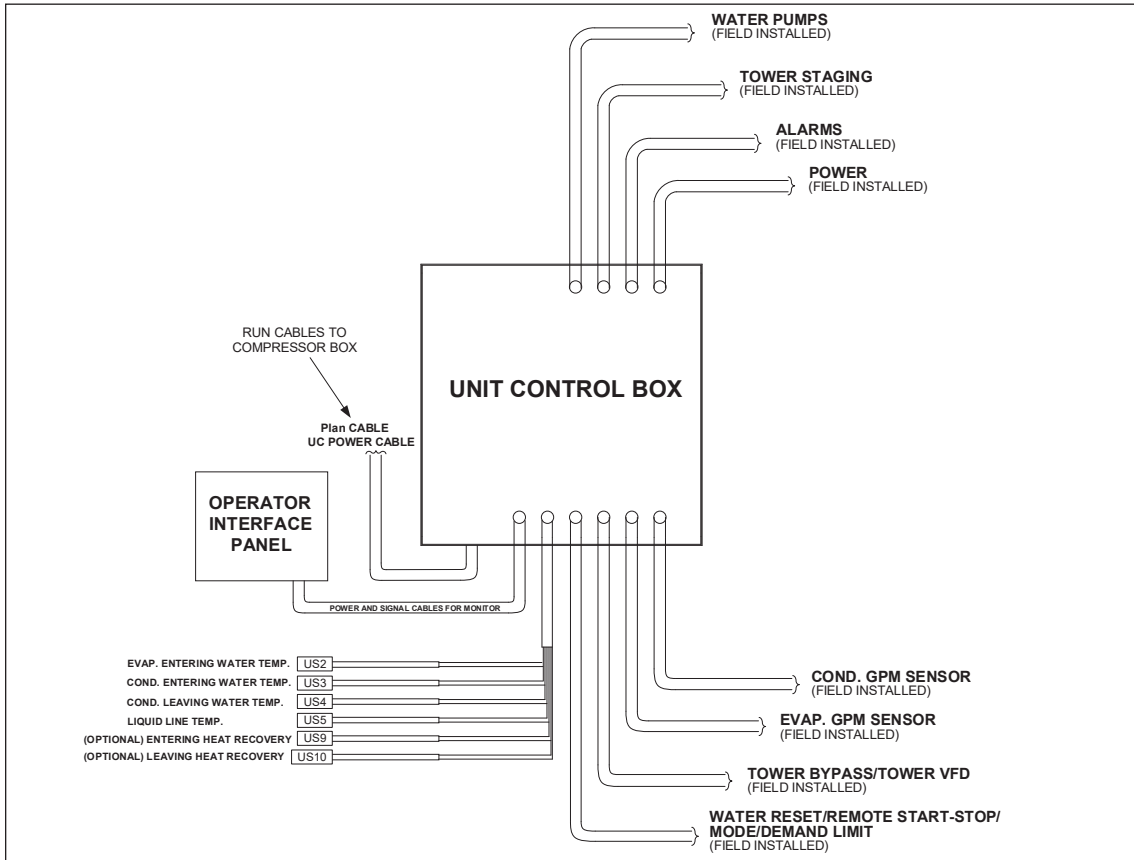

Figure 33: Unit Electrical and Sensor Locations

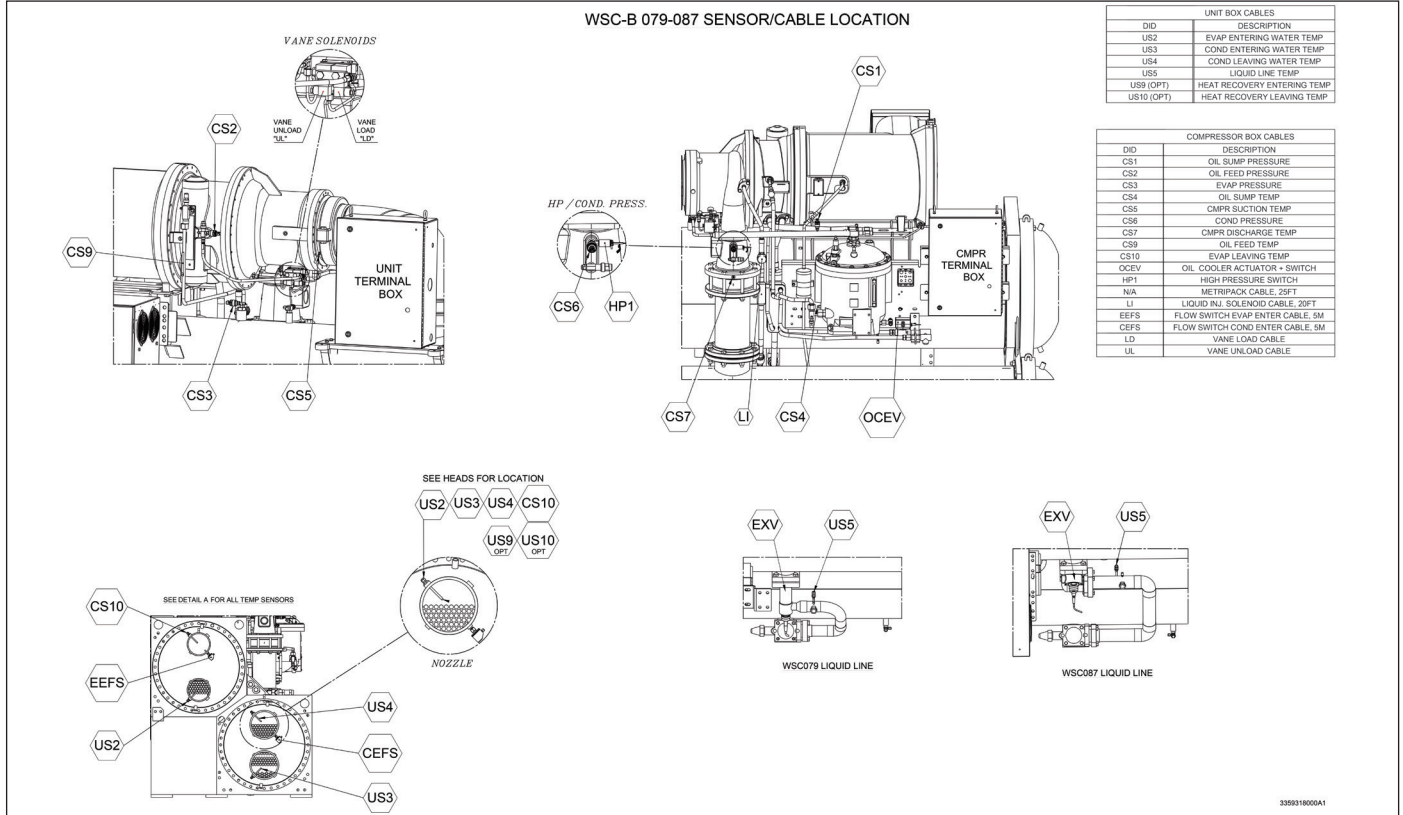

Figure 34: Unit Electrical and Sensor Locations

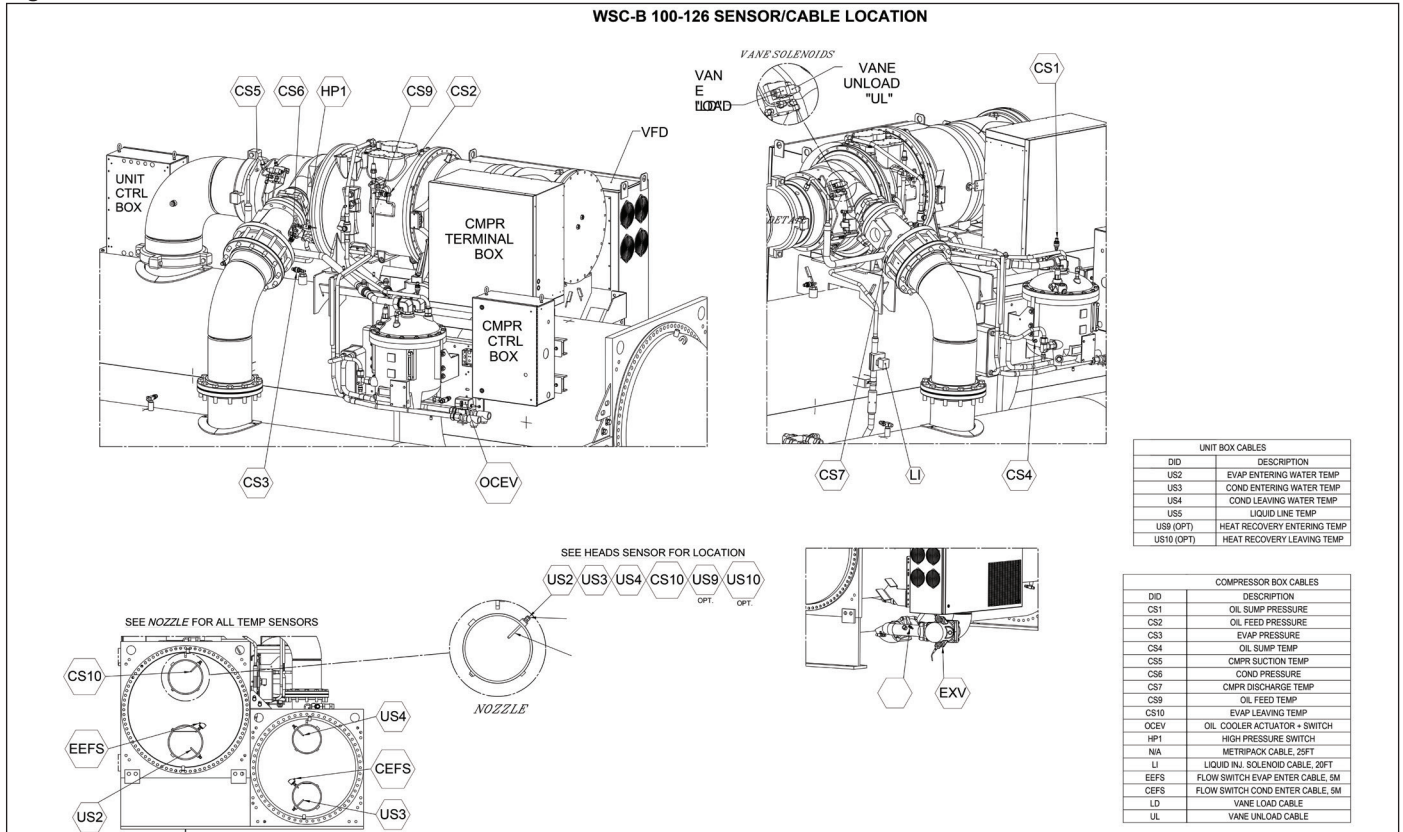
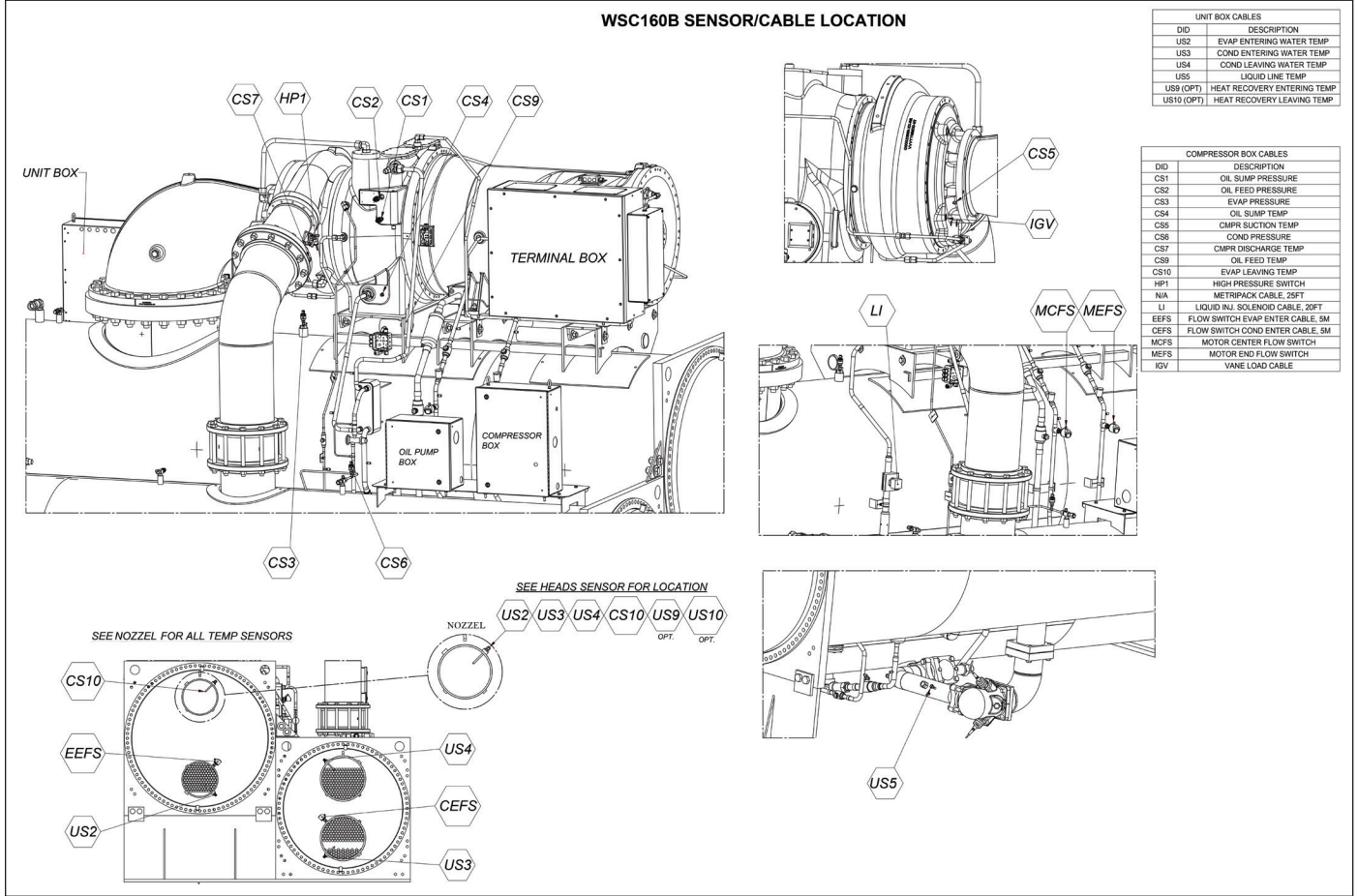

Figure 35: Unit Electrical and Sensor Locations



Operation

WARNING

Electric shock hazard. Can cause personal injury or equipment damage. This equipment must be properly grounded. Connections to and service of the MicroTech control panel must be performed only by personnel that are knowledgeable in the operation of the equipment being controlled.

CAUTION

Static sensitive components. A static discharge while handling electronic circuit boards can damage components. Discharge any static electrical charge by touching the bare metal inside the control panel before performing any service work. Never unplug any cables, circuit board terminal blocks, or power plugs while power is applied to the panel.

CAUTION

Do not install any non-Daikin Applied authorized software or alter operating systems in any unit microprocessor, including the interface panel. Failure to do so can cause malfunction of the control system and possible equipment damage.

Dual/Multi-Chiller Operation

Multiple Chiller Setup

Single compressor chillers WSC and dual compressor chillers WDC and WCC have their main control components factory wired to an internal pLAN network so that the components can communicate with each other, within the chiller itself. On multi-chiller applications, up to four chillers, either single, or dual compressor, can be interconnected by this internal pLAN. All that is required is simple field RS485 interconnecting wiring, the addition of accessory communication isolation board(s) 485OPDR (Daikin Applied P/N 330276202), and MicroTech II control settings. (If applicable, additional WCC instructions should be referenced in the current Installation, Operation, and Maintenance manual for dual centrifugal chillers.). The isolation board can be purchased with the unit or separately, during or after chiller installation. The number of boards required equals the number of chillers minus one.

NOTE: pLAN multiple chiller interconnection is designed for parallel chiller installations with the leaving water sensors in their normal location in the outlet nozzle.

For two units in series operation, the leaving chilled water sensors must be moved far enough downstream from the last chiller to insure reading a thoroughly mixed water temperature. Passing through one or two elbows will usually suffice. Series chillers are normally single pass resulting in undesirable temperature stratification at the outlet nozzle.

Connectability

Centrifugal models WSC and WDC of various vintages with MicroTech controllers can be interconnected, but all must be loaded with the most recent control software.

Responsibilities

Unless otherwise stated in the contract documents, the interconnecting MicroTech pLAN RS485 multiple chiller wiring between chillers is the responsibility of the installing contractor and should be completed prior to startup. The Daikin Applied startup technician is responsible for checking the wiring and making the appropriate control changes.

pLAN Wiring

The first chiller in the connection can be designated as Chiller A. The isolation board is attached to the DIN rail adjacent to the Chiller A compressor controller. The isolation board has a pigtail that is plugged into J10 on the controller. Most chillers will already have a universal communication module (UCM) that connects the controller to the touchscreen already plugged into J10. If this is the csae, plug the isolation module pigtail into the empty RJ11 pLAN port on the UCM. This is equivalent to plugging into the unit controller directly.

Two Chillers: If only two chillers are to be connected, Belden M9841 (RS 485 Spec Cable) is wired from the isolation board (terminals A, B, & C) on Chiller A to the J11 port on the unit controller of Chiller B. At J11, The shield connects to the GND, the blue/white wire to the center (+) connection, and the white/blue to the (-) connection. Note that Chiller B does not have an isolation board. The last chiller (B in this case) to be connected does not need an isolation board.

Three or Four Chillers: If three or four chillers are to be connected, the interconnecting wiring is still made to B's J11 port. The second chiller (Chiller B) must have an isolation board that will be plugged into Chiller B's UCM pLAN port. Chiller B will look like Chiller A. The wiring from Chiller B to Chiller C will be the same as Chiller A to B. That is, Belden cable connects from A, B, and C on B's isolation board to Chiller C's J11 port. Chiller C has no isolation board. The procedure is repeated to the fourth chiller if four chillers are interconnected.

Figure 36: pLAN Communication Wiring

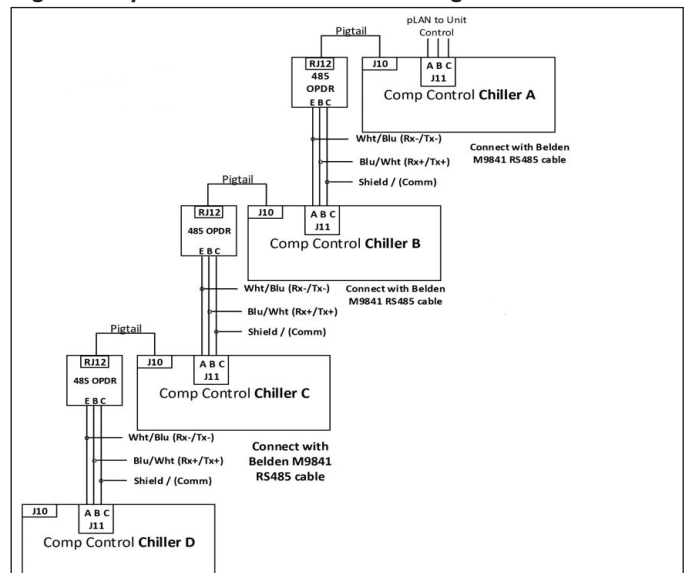

Sequencing

The Daikin Applied technician can set up different strategies for starting and stopping networked compressors, chillers, and pumps depending on site requirements.

The same Modes setting must be replicated on each chiller in the system.

Operating Sequence

For multiple-chiller, parallel operation, the MicroTech controllers are tied together by a pLAN network and stage and control compressor loading among the chillers. Each compressor, single or dual compressor chiller, will stage on or off depending on the sequence number programmed into it. For example, if all are set to “1”, the automatic lead/lag will be in effect.

When chiller #1 is fully loaded, the leaving chilled water temperature will rise slightly. When the delta-T above setpoint reaches the Staging delta-T, the next chiller scheduled to start will receive a start signal and start its pumps if they are set up to be controlled by the MicroTech controller. This procedure is repeated until all chillers are running. The compressors will load-balance themselves.

If any of the chillers in the group are dual compressor, they will stage and load according to the staging instructions.

Ice Mode Operation

If available modes is set to ICE only the chiller will start (at start delta-T) and run the Ice cycle described as follows: The chiller will ignore softload and all demand limits and rapidly load up to Maximum Amps setpoint. The compressor does not unload. When the Ice LWT setpoint has been achieved, the compressor will shutdown. The evaporator pump will continue to run and if the evaporator LWT climbs to the Start Delta T the chiller will restart this process.

If available modes is set to Cool/Ice with Ice mode operation selected, the chiller will run one ICE cycle and shutdown (compressors and pumps) no automatic restart allowed. When the operator switches the chiller from Ice to Cool mode the chiller will reset for operation. Changing modes can be done through the Human Machine Interface (HMI), switches or BAS interface, which ever is selected.

A method of migration freeze protection needs to be in place when the chiller terminates ice mode. This is usually sensed by the liquid line sensor and forces a condenser pump to circulate to prevent freeze up of the condenser.

Operator Responsibilities

It is important that the operator become familiar with the equipment and the system before attempting operation. During the initial startup of the chiller, the Daikin Applied technician will be available to answer any questions and instruct the proper operating procedures. It is recommended that the operator maintain an operating log for each individual chiller unit. In addition, a separate maintenance log should be kept of the periodic maintenance and servicing activities.

Operator Schools

Training courses for centrifugal maintenance and operation are held through the year at the Daikin Learning Institute in Verona, Virginia. The school curriculum includes instruction on basic refrigeration, MicroTech® controllers, enhancing chiller efficiency and reliability, MicroTech® troubleshooting, system components, and other related subjects. For more information, visit us at www.DaikinApplied.com and click on Training or call the Training Department. Refer to the back cover of this document for contact information.

Unit Enabling/Disabling

There are multiple options that will enable and disable the chiller and its compressors:

1. Unit Button - Located on the upper right hand corner of the HMI
2. Unit Enable Setting - Located in the Settings menu, Modes tab in the HMI.
3. Manual Button - Located on the outside, front of the control panel.
4. Remote Enable - Optional signal from a remote physical switch or BAS signal. Replaces a jumper located on terminal connection J31

The switches listed above work in conjunction with the “Control Source” that is selected in the HMI via the Settings/Modes Screen. (See [Figure 54](#) and [Table 15](#) on [page 48](#).) The three options for “Control Source” are:

1. Local - When this mode is set, a STOP button and an AUTO button will appear at the top of the HMI screens. **This mode will ignore all functionality of a connected Remote Switch.** It will also ignore BAS commands.
2. Switches - This is the default mode and will ignore BAS commands.
3. Network BAS - This mode adds BAS capability to the Digital Input functionality.

Enabling and disabling the unit and its compressors using the switches in conjunction with the selected “Control Source” are discussed next.

Enabling

To enable the chiller and its compressors when the “Control Source” is “Switches” or “BAS,” all rocker switches (three rocker switches for single compressor units, four rocker switches for dual compressor units) and the Remote Switch, if included, need to be closed (in the ON position).

If the “Control Source” is set to “Local” and a Remote Switch is being used, the position of the Remote Switch will be ignored. In that case, only the rocker switches need to be closed. Once these rocker switches are closed, press the AUTO button on the HMI to enable the chiller in “User” mode.

Disabling

Each of the four switches located on the unit have a different functionality in terms of disabling. The descriptions below apply if the “Control Source” on the HMI MODES Setpoint Screen is set to “Switches” or “BAS.”

1. Unit Switch- When placed in the OFF position while the chiller is running, the Unit Switch will shutdown the chiller in a normal controlled sequence and will stop each compressor that is running. This switch will leave the entire chiller disabled until it is set in the ON position.
2. External Switch - This switch will disable the chiller in a similar manner as the Unit Switch.
3. Remote Switch - This switch will disable the chiller in a similar manner as the Unit Switch.

If the “Control Source” on the HMI MODES Setpoint Screen is set to “Local,” press the STOP button on the HMI to disable the chiller. This method of disabling will cause the chiller to act in a similar manner as when it is disabled using the Unit Switch in the “Switches” or “BAS” mode.

Human Machine Interface (HMI)

The HMI is turned on/off with a switch located at the lower right-hand edge of the display panel. Screen control buttons are located to either side of it and elicit on-screen prompts when pressed. The HMI is equipped with a screen saver (a blank, black screen). If the screen is black, touch it first to be sure it is on before using the ON/OFF button.

Chiller Operation Without the HMI

The Human Machine Interface (HMI) communicates with the unit control processor, displaying data and transmitting touch screen inputs to the controllers. It does no actual controlling and the chiller can operate without it. Should the touch screen become inoperable, no commands are necessary for continuing unit operation. All normal inputs and outputs will remain functional. A PC monitor and USB mouse can be connected to the unit control processor via its VGA and USB ports and can be used to view operational data, to clear alarms, and to change setpoints, if necessary. See “Controller Inputs and Outputs” section starting on page 62 for more information.

Navigation Summary

The Home View Screen, see Figure 38, is the main information page for the chiller. This screen contains the AUTO and STOP buttons in the upper right hand corner, which are used to start and stop the unit when in “User” control mode. Other groups of screens can be accessed from the Home View Screen by pressing one of the icons on the bottom of the screen.

An initial startup step may be to select the Operator icon on the bottom right of the HMI to access the Operator screen (Figure 37) to set display language and unit of measure preferences as well as input the appropriate level of password for making unit adjustments going forward. Should the touch screen cursor not respond to where the screen is being pressed, use the Calibrate button to recalibrate the screen. The bar was made longer to make it easier for the non-calibrated cursor to select.

Figure 37: Operator View Screen



Figure 38: Home View Screen



The Home View Screen (Figure 38) shows the basic operating condition of the chiller. Note that the chiller displayed on all screens will be representative of the actual chiller, showing either one or two compressors depending on the chiller model. Other unit options and order details are not specific to the HMI image.

(I) **Consistent Information** The top banner across all screens will always show the following:

- Actual leaving water temperature
- Chilled water setpoint
- Date and Time
- Chiller Control Source
- Unit Status - the possible status combinations are shown in Table 11 and discussed below.

Table 11: Unit Status Possibilities

MAIN MODE	STATE	SOURCE (for stop)
Cool	Off	Manual/Mechanical Switch
Ice	Shutdown	Remote Switches
Heat	Auto	Local Unit
		BAS Network

- Chiller can only be in one of the three main operating modes at a time; however, the available mode setpoint may be a combination of COOL, w/ GLYCOL, ICE, and HEAT. For example, Cool/Ice w/ Glycol is an available mode setpoint but the chiller can only be in either COOL or ICE mode at any given time. "Figure 54: Settings View - Modes" on page 48 gives more information.
- Compressor Status, shown for each unit compressor (#1 only for single compressor units, both #1 and #2 for dual compressor units), is Mode followed by State followed by the Source device or signal. The possible combinations are shown in Table 12.

Table 12: Compressor Status Possibilities

Complete STATUS Text (in priority sequence)	Notes	
OFF Manual Switch	Reason for the compressor being off	
OFF Compressor Alarm		
OFF Unit State		
OFF Evap Flow/Re-circulate		
OFF Low Oil Sump Temp		
OFF Start to Start Timer = xxx		
OFF Stop to Start Timer = xxx		
OFF Staging (Next ON)	Compressor is in START state - Current state of the Prelube sequence	
OFF Awaiting Load		
PRELUBE Vanes Open		
PRELUBE Timer=xxx		
PRELUBE Condenser Flow		
RUN Unload Vanes-Max Amps		Overrides water temperature command
RUN Hold Vanes-Max Amps		
RUN Manual Vanes & Speed	Used for service purposes. "T" password required. Operated from compressor controller	
RUN Load Vanes-Manual Speed		
RUN Hold Vanes-Manual Speed		
RUN Unload Vanes-Manual Speed		
RUN Load Speed-Manual Vanes		
RUN Hold Speed-Manual Vanes		
RUN Unload Speed-Manual Vanes	Overrides water temperature command	
RUN Unload Vanes-Lag Start		
RUN Hold Vanes-Evap Press		
RUN Unload Vanes-Evap Press		
RUN Unload Vanes-Soft Load		
RUN Hold Vanes-Soft Load		
RUN Load Vanes-Disch Temp	Normal operation	
RUN Hold Vanes-Pull-down Rate		
RUN Unload Vanes-Demand Limit		
RUN Hold Vanes-Min Amps		
RUN Load Vanes		
RUN Hold Vanes		
RUN Unload Vanes	Unloading during the shutdown sequence	
SHUTDOWN Unload		
POSTLUBE Timer=xxx		Postlube timer on
POSTLUBE Motor Current High	Compressor motor running during the shutdown mode. It should be off.	

NOTE: Timer countdown values will be shown in place of “xxx”.
For a VFD equipped compressor, “Vaness” or “Speed” is shown in the RUN state to indicate if the capacity is controlled by speed from the VFD or by vane control.

The bottom icon bar will be visible on all screens with the active screen highlighted in white.

(II) Unit Status Modes - Defined by Mode followed by State. If the unit is stopped, the Source would be listed after State. Various unit states and control sources are shown as examples in Figure 39 to Figure 41.

Figure 39: Mechanical Switch Source

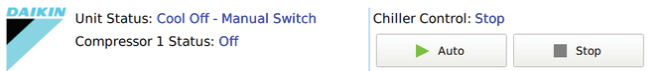

Figure 40: Remote Switches Source



Figure 41: BAS Network Source



(III) Additional Home View Trend Data Graphs

- Entering and leaving evaporator water temperatures
- Entering and leaving condenser water temperatures
- Percent compressor RLA
- Compressor kW (will read 0 without Full Metering Option)

(IV) Alarm

- The ALARM icon will turn red and begin flashing should an alarm occur. This red ALARM button will appear on all screens in the case of an alarm. See Figure 42 for an example of an active alarm alert. For more information on alarms, see page 58.

Figure 42: Active Alarm Icon



Additional HMI View Screens

Pressing the Detail Tab on the top of the Home View Screen provides specific unit operating parameters shown in Figure 43. Chiller Model “WCF” is the general software category for WSC, WDC, WCC, TSC, TDC, and HSC models (see “Figure 54: Settings View - Modes” on page 48).

If a Technician level password is entered, two additional tabs will follow the Detail Tab. The Tech Data Tab will show compressor staging and pLAN communication. On the Tech I/O Tab, the technician will find all inputs and outputs, both analog and digital, at both the Unit Controller and Compressor Controller levels.

To make setpoint adjustments or change operating parameters, tap on the Settings icon at the bottom of the screen; Figure 51 on page 46.

Figure 43: Unit Detail View Screen



Figure 44: Evaporator Information



Figure 45: Compressor Details



NOTE: Chiller data will populate in the Power box if the Full Metering capability has been installed and wired.

The Compressor State Information on the right side of the screen is a compilation of the events that the chiller sequences through at startup. A green light indicates that a particular sequence requirement has been satisfied. It is recommended that this information be viewed during the startup sequence. One can see the requirements light up as they are met and also determine why a non-start may have occurred. Similarly during the shut down process, the sequence transitions back to "Off" and the highlight color will switch to black.

The left side information displays the status of the compressor inputs and outputs in greater detail than on the Home Detail screen (Figure 43). Compressor information will populate in the Power data box if the Full Metering card has been installed and wired; otherwise zeros will be shown or the Power box will not display on the HMI. Compressor related setpoint adjustments can be made within the Settings screen on the Modes and Motor tabs.

Capacity Control System

The opening or closing of the inlet vanes controls the quantity of refrigerant entering the impeller thereby controlling the compressor capacity. For WSC 079-126 models, the vane movement occurs in response to oil flow from the vane load/unload SA or SB 4-way solenoid valves, which in turn, respond to instructions from the unit microprocessor as it senses leaving chilled water temperature. This oil flow activates a sliding piston that rotates the vanes.

Vane Operation

The hydraulic system for the inlet guide vane capacity control operation consists of a 4-way normally open solenoid valve located in the oil management control panel or on the compressor close to the suction connection. Oil under pressure from the oil filter is directed by the 4-way valve to either or both sides of the piston, depending on whether the control signal is to load, unload, or hold as illustrated in Figure 46.

To open the vanes (loading compressor), solenoid SA is de-energized and SB is energized, allowing oil flow from port SA to one side of the piston; other side drains through port SB.

To close the vanes (unload compressor), valve SB is de-energized and valve SA is energized to move the piston and vanes toward the unload position.

When both solenoid valves SA and SB are de-energized, full oil pressure is directed to both sides of the piston through ports SA and SB, and the vanes are held in that position. Refer to Figure 47 on page 43 for solenoid action. Note that both solenoids cannot be energized simultaneously.

Vane Speed Metering Valves

The speed at which the capacity control vanes are opened or closed can be adjusted to suit system operating requirements. Adjustable needle valves in the oil drain lines are used to control the rate of bleed-off and consequently the "vane speed". These needle valves are part of the 4-way solenoid valve assembly located in the compressor lube box. For unit and system balancing through pLAN communication, it is important to have the Opening (Load) and Closing (Unload)

speeds be as close as possible and must be within 30 seconds of each other. The valves are factory set so that the vanes will move from fully closed to fully opened in the times shown in Table 13.

Table 13: Vane Speed Factory Setting

Compressor Model	Opening Time	Closing Time
CE079 - CE100	3-5 min	3-5 min
CE113 - CE126	5-8 min	5-8 min

The start-up technician may readjust the vane speed at initial start-up to meet job conditions. The speed must be slow enough to prevent over-controlling and hunting. These adjustments are sensitive. Turn the adjusting screws a few degrees at a time.

The left adjusting screw is the SB needle valve for adjusting the vane OPENING speed for loading the compressor. Turn this screw clockwise to decrease the vane opening speed and counterclockwise to increase the opening speed.

The right adjusting screw is the SA needle valve for adjusting the CLOSING speed to unload the compressor. The same adjustment method applies - clockwise to decrease closing, counterclockwise to increase vane closing.

Figure 46: Vane Control Operation - Models 079-126

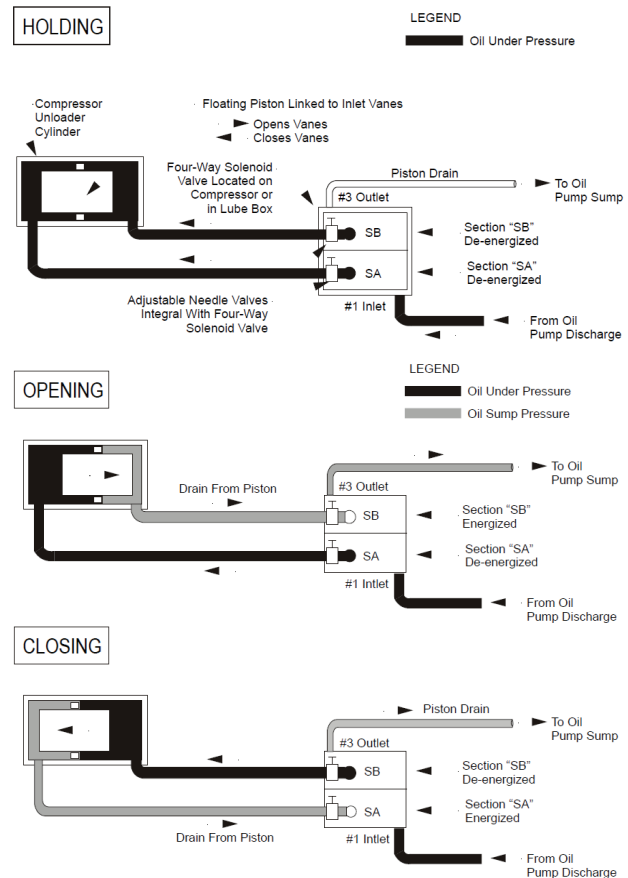

Capacity Overrides

Compressor capacity is determined by the status of the leaving chilled water temperature (LWT), which is a direct indicator of whether the chiller is producing enough cooling to satisfy the cooling load. The LWT is compared to the active chilled water setpoint, and compressor loading or unloading ensues, considering any capacity overrides that may be in effect.

The unit may experience a condition that will override normal capacity control. Of the following limits, the one creating the lowest capacity limit is in effect.

Low Evaporator Pressure

If the evaporator pressure drops below the Low Evap Pressure – Inhibit setpoint, the unit will inhibit capacity increases. If the evaporator pressure drops below the Low Evap Pressure - Unload setpoint, the unit will begin capacity decreases.

High Motor Temperature

If the highest motor stator temperature is above the limit, the unit will adjust capacity to keep the temperature within the limits.

Demand Limit

The maximum amp draw of the compressor(s) can be limited by a 4 to 20 mA signal on the Demand Limit analog input. This function is only enabled if the Demand Limit Enable setpoint is set to ON. The amp limit decreases linearly from the Maximum Amp Limit setpoint (at 4 mA) to the Minimum Amp Limit setpoint (at 20mA). While this override is in effect, chiller capacity is continuously adjusted to keep the % RLA near the requested demand limit.

Network Limit

The maximum amp draw of the compressor (s) can be limited by a value sent through a BAS network connection and stored in the Network Limit variable. While this override is in effect, chiller capacity is continuously adjusted to keep the % RLA near the requested demand limit.

Maximum Amp Limit

The maximum amp draw of the compressor(s) is always limited by the Maximum Amps setpoint. This limit has priority over all other functions including manual capacity control. While this override is in effect, chiller capacity is continuously adjusted to keep the % RLA near the limit value.

Hot Gas Bypass

All units can be equipped with an optional hot gas bypass system that feeds discharge gas directly into the evaporator. Light load conditions are signaled by measurement of the ELWT temperature or percentage of RLA by the MicroTech controller depending on which Hot Gas mode is selected. When the RLA or ELWT drops to the setpoint, the hot gas bypass solenoid valve is energized, making hot gas bypass available for metering by the hot gas regulating valve. This hot gas provides a stable refrigerant flow and keeps the chiller

from short cycling under light load conditions, while also reducing surge potential on heat recovery units

The factory default setpoints for bringing on hot gas bypass are adjustable on Settings - Modes tab shown on “Figure 54: Settings View - Modes” on page 48.

Surge and Stall

Stall and surge are characteristics of all centrifugal compressors. These conditions occur when low load combines with high compressor lift. In a stall, discharge gas has insufficient velocity leaving the impeller to reach the volute and just “sits” or stalls in the diffuser section. The compressor sound level goes way down due to no flow and the impeller starts to heat up. In surge, the heated discharge gas alternately flows back through the impeller and then reverses to the volute about every two seconds. Extreme noise and vibration occur. The compressor is equipped with a temperature sensor that shuts it off if these conditions occur.

Lubrication System

The lubrication system provides lubrication and heat removal for compressor bearings and internal parts. In addition, the system provides lubricant under pressure to hydraulically operate the unloading piston for positioning the inlet guide vanes for capacity control.

Only the recommended lubricant can be used for proper operation of the hydraulic system and bearing lubrication system. Each unit is factory-charged with the correct amount of the recommended lubricant. Under normal operation, no additional lubricant is needed. Lubricant must be visible in the sump sight glass at all times.

Compressor sizes, CE079 through CE126, utilize a separate lubricant pump located in the sump. The sump includes the pump, motor, heater and lubricant/vapor separator system. The lubricant is pumped through the external oil cooler and then to the oil filter located inside the compressor housing. WSC models 079-126 units utilize a water-cooled oil cooler for the compressor. The oil coolers maintain the proper oil temperature under normal operating conditions. The coolant flow control valve maintains 95°F to 105°F (35°C to 41°C). Lubrication protection for coast down in the event of a power failure is accomplished by a spring-loaded piston in models CE079 through 087. When the oil pump is started, the piston is forced back against the spring by the oil pressure, compressing the spring, and filling the piston cavity with oil. When the pump stops, the spring pressure on the piston forces the oil back out to the bearings. In compressor model CE 100 - 126 the compressor coast down lubrication is supplied from a gravity-feed oil reservoir.

Figure 47: Typical Oil Flow Diagram - Models WSC/TSC/HSC 079-126

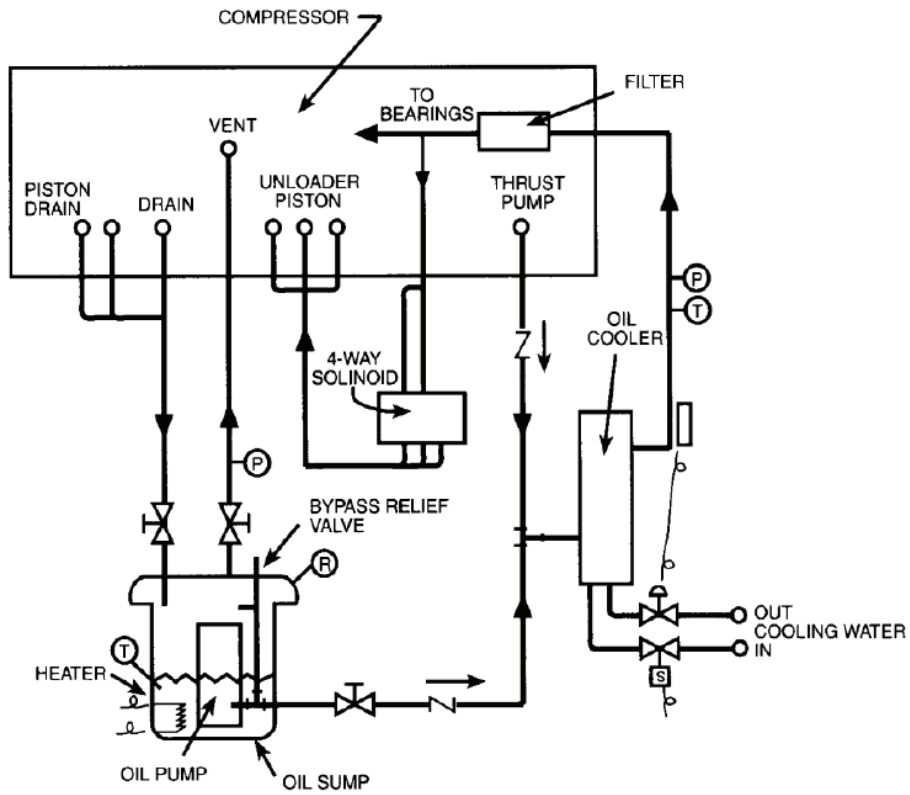

Figure 48: Condenser Information



Figure 49: Expansion Valve Information



Figure 50: Cooling Tower Information



NOTE: Selection and setup of cooling tower control methods is in the Settings icon, Tower tab, see Table 17 on page 50.

SET Screens

The Setpoint Screens on the Human Machine Interface (HMI) are used to input the various setpoints associated with equipment of this type. (Note that if the HMI is unavailable, setpoints can be changed by connecting a laptop or by remote access.) Appropriate setpoints are factory set and checked by a Daikin Applied service representative during commissioning; however, adjustments and changes are often required to meet job conditions. Certain settings involving pumps and tower operation are field set.

Pressing the Settings icon found at the bottom of every screen accesses the last Setpoint tab used. There are nine setpoint tabs accessible across the top of the Settings screen:

1. WATER, sets leaving water temperature setpoint, start and stop delta-T, resets, etc.
2. MODES, selects various unit parameters such as liquid injection, timers, pump staging, control source, unit mode, etc.
3. MOTOR, selects power related setpoints such as amp limits.
4. TOWER, selects the method of controlling the cooling tower and sets the parameters for fan staging/VFD.
5. ALARMS, sets the limit and shutdown alarms.

6. TIMERS, sets the amount of time the evaporator pump must run before a compressor can start.
7. INTERFACE, sets the network protocol and associated options.

A typical Setpoint Screen is displayed in Figure 51. A list of setpoints along with their default value, available setting range, and password authority can be found in the tables after each Setpoint Screen, starting on page 47. The WATER button, for example, contains various setpoints relating to water temperature setpoints.

In Table 14 and in the rest of the Setpoint tables on the following pages, the letters in the Password column refer to the following:

- M = Manager Level (The password number will be supplied by Daikin Applied service at startup.)
- O = Operator Level (The password number for operator level is 100.)
- T = Technician Level (The password number for technician level is only provided to Daikin Applied technicians.)

Figure 51: A Typical Setpoint Screen

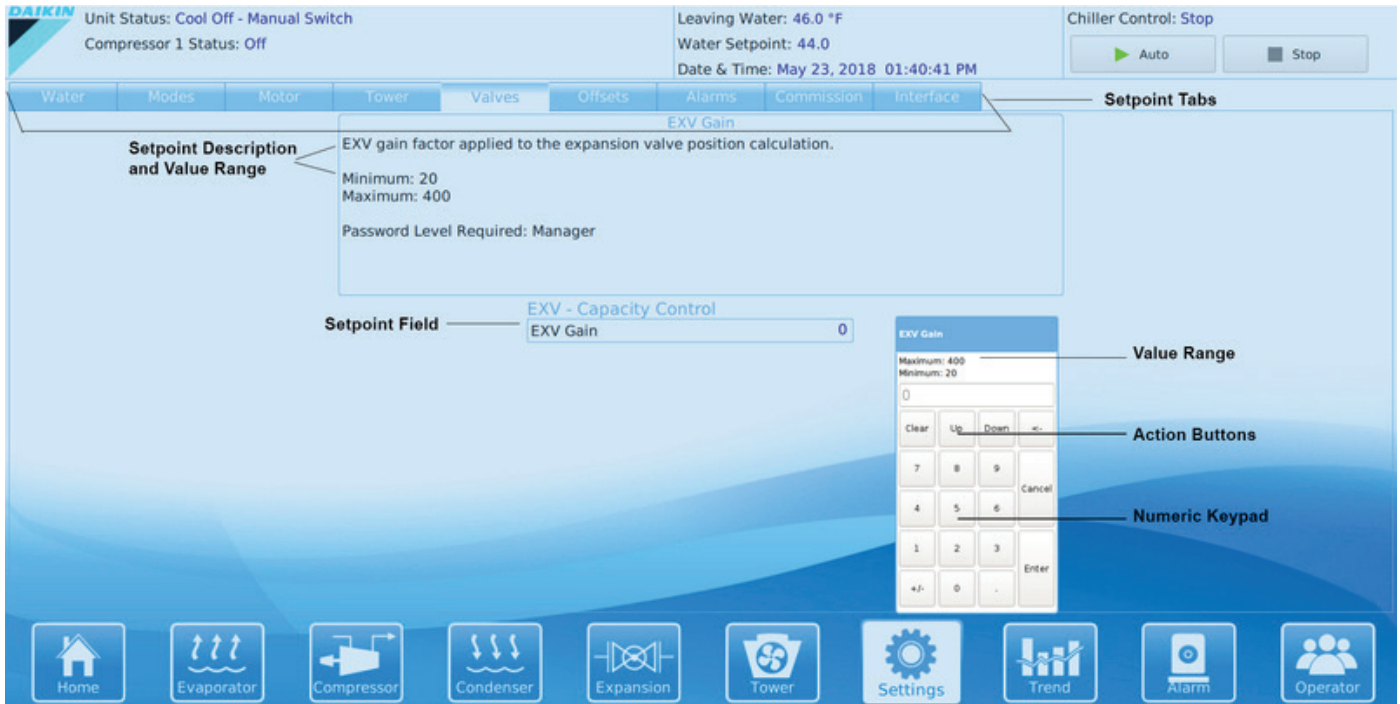

Procedure for Changing a Setpoint

1. Press the applicable Setpoint Group.
2. Select the desired setpoint by pressing the numbered Setpoint Field.
3. A password must be entered before changing any setpoint value. A keypad prompt will appear to enter a password and then the keypad or drop down menu will appear to make the desired change. .

Input the appropriate password number. (Use 100 for operator level. The technician level password number is only provided to Daikin Applied technicians.) There is a small delay between pressing the keypad and recording the entry. Be sure that an asterisk appears in the window before pressing the next number.

4. Setpoints with numeric values can be changed in two ways:
 - Select the desired value by pressing the numbered buttons on the Numeric Keypad.
 - Press the UP or DOWN button to increase or decrease the value displayed.

Some setpoints are selectable text menus rather than numeric values. Select the desired option using the drop down menu that appears on that particular setpoint. Toggle between choices using the UP or DOWN button. If dashed lines appear in the setpoint window it means that toggling in that direction can go no further, so reverse direction.

5. Additional setpoints can be changed by selecting another setpoint on the screen using the Setpoint Selection buttons or by selecting an entirely new group of setpoints using the Setpoint Group buttons.

⚠ CAUTION

Many setpoints are interactive. Changes may have an adverse effect on chiller operation. Only trained operators should be allowed to change chiller setpoints.

NOTE: Setpoints that have a technician level password (T) should only be changed by a Daikin Applied technician. Contact a Daikin Applied service representative for more information.

Leaving Water Temperature (LWT) Reset

The Active Leaving Water variable shall be set to the current Leaving Water Temperature (LWT) setpoint unless modified by one of the reset methods below. (The current LWT setpoint is Cool LWT as determined by the chiller mode.) The type of reset in effect is determined by the LWT Reset Type setpoint (Setpoint 6 of the WATER Setpoint Screen).

Figure 52: Settings View - Water

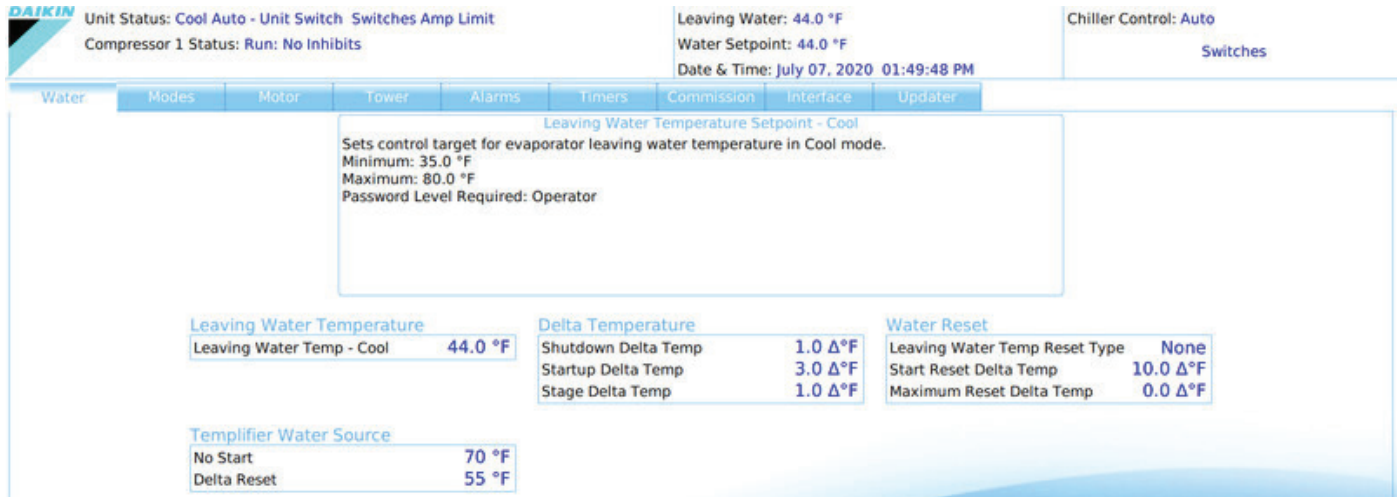

Table 14: Water Setpoints

Description	Default	Range	PW	Comments
Maximum Reset Delta-T	0.0 °F	0.0 to 20.0 °F	T	Reset Type = Return: Sets the maximum LWT reset that can occur. Reset Type = 4-20 mA: Sets amount of reset at 20 mA input.
Start Reset Delta-T	10 °F	0.0 to 20.0 °F	T	Sets evaporator delta-T above which Return reset begins.
LWT Reset Type	None	None Return 4-20mA	T	Reset raises LWT setpoint Return (uses start Reset Delta T & Max Reset Delta T) 4-20 mA (4 mA=None, 20 mA=Max as set by Max Reset Delta T)
Startup Delta-T	3.0 °F	0 to 10.0 °F	T	Sets amount leaving water must go above for first compressor to start. For Templifier units, set the temperature delta below leaving water for compressor to start.
Shutdown Delta-T	3.0 °F	0 to 3.0 °F	T	Sets amount leaving water must drop below setpoint for last compressor to stop. For Templifier units, set the temperature delta above leaving water for compressor to stop.
Stage Delta-T	1.0 °F	0 to 9.9 °F	M	Sets amount leaving water must go above setpoint for next compressor to start.
Leaving Water Temp - Cool	44.0 °F	35.0 to 80.0 °F	O	Sets control target for evaporator leaving water temperature in COOL mode. 35 °F is lowest setpoint for shutdown.
Leaving Water Temp - Cool w/ Glycol or Cool / Ice	44.0 °F	15.0 to 80.0 °F	O	Sets control target for evaporator leaving water temperature in Cool with Glycol or Cool / ICE mode. When running in the ICE portion of the mode, the temperatures limit to the lower range of 15-35 °F.
Leaving Water Temp - Ice	25.0 °F	15.0 to 35.0 °F	O	Sets control target for evaporator leaving water temperature in ICE mode.
Leaving Water Temp - Heat	135.0 °F	66.0 to 150.0 °F	O	Sets control target for condenser leaving water temperature in HEAT mode.
No Start - Water Source	70 °F	30 to 100 °F	O	Minimum temperature for starting a Templifier unit
Delta Reset - Water Source	55.0 °F	50 to 100 °F	O	Setting for Templifier models

Reset Type – NONE - The Active Leaving Water variable is set equal to the current LWT setpoint.

Reset Type – RETURN - The Active Leaving Water variable is adjusted by the return water temperature. When the chiller mode = COOL, the Active Leaving Water variable is reset using the following parameters:

1. Cool LWT setpoint
2. Max Reset Delta T setpoint
3. Start Reset Delta T setpoint

Reset is accomplished by changing the Active Leaving Water variable from the (Cool LWT setpoint) to the (Cool LWT setpoint + Max Reset Delta-T setpoint) when the evaporator (return – leaving) water temperature delta varies from the (Start Reset Delta-T setpoint) to 0.

Reset Type – 4-20mA - The Active Leaving Water variable is set equal to the Cool LWT setpoint if the reset signal is less than or equal to 4 mA. It is set equal to (Cool LWT setpoint + Max Reset Delta T setpoint) if the reset signal equals or exceeds 20 mA. The Active Leaving Water variable will vary linearly between these extremes if the reset signal is between 4 mA and 20 mA. An example of this action is shown in Figure 53; temperatures are examples only.

Figure 53: LWT Reset (Cool Mode)

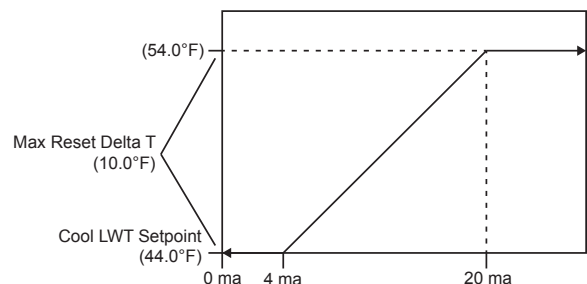

Figure 54: Settings View - Modes

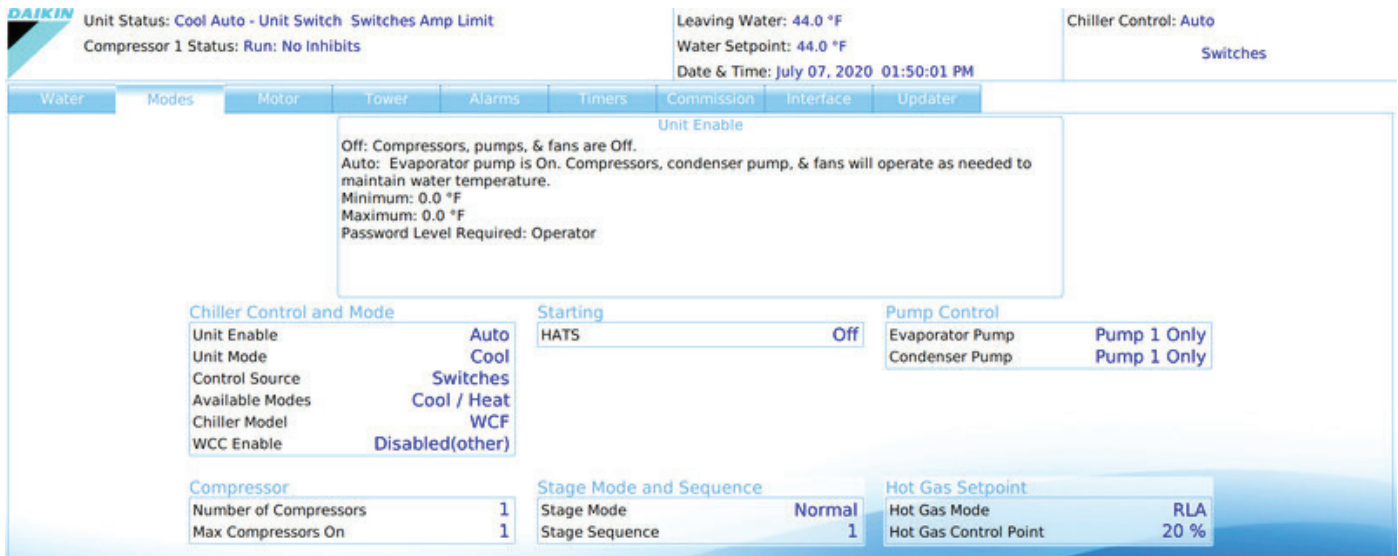

Table 15: Modes Setpoints

Description	Default	Range	PW	Comments
Chiller Model	WCF	WCF, WMC	T	WCF is the general software model for WSC (HSC), WDC, WCC, TSC, and TDC. Heat Recovery option is enabled on Commission tab shown in Figure 72 on page 57.
WCC Enable	Disabled (other)	Enabled (WCC), Disabled (other)	T	Will always be Disabled for WSC chillers
Control Source	Switches	Switches, Local, Network BAS	O	Sets control source. See "Unit Enabling/Disabling" on page 36.
Unit Enable	OFF	OFF, AUTO	O	OFF: everything is off. AUTO: evap pump on, comp, cond pump and tower on as required to meet LWT
Available Modes	Cool/Heat	Cool Only, Cool w/ Glycol, Cool/ Ice w/ Glycol, Ice Only w/ Glycol, Cool/Heat, Heat Only	M	See Water Setpoints, Table 14, for control temperature targets for each mode
No. of Compressors	1	1 to 2	T	WSC models will be set to 1. Any other value will be ignored.
Max Compressors On	2	0 to 8	M	Max number of compressors that can be on local pLan chiller network
HATS - Starting	Off	Off, Chiller, System	M	High Ambient Tandem Start
Condenser Pump	Pump #1 Only	Pump #1 Only, Pump #2 Only, Auto Lead, #1 Primary, #2 Primary	M	Pump #1 Only, Pump #2 Only, use only these pumps AUTO, balance hours between #1 and #2 #1 Primary, #2 Primary, if primary fails, use other
Evaporator Pump	Pump #1 Only	Pump #1 Only, Pump #2 Only, Auto Lead, #1 Primary, #2 Primary	M	Pump #1 Only, Pump #2 Only, use only these pumps AUTO, balance hours between #1 and #2 #1 Primary, #2 Primary, if primary fails, use other
Stage Mode	Normal	Normal, Hi Eff, Pump, Standby	M	Normal - Fixed sequence and /or balance starts/hours. Hi Eff - Starts compressor on each dual compressor chiller first Pump - Starts all compressors on one chiller first. Standby - Use compressor only if another fails.
Stage Sequence	1	0-99	M	Sets fixed sequence for compressor staging
Hot Gas Mode	RLA	Off, Water, RLA	T	See below
Hot Gas Control Point	20%	20 to 70%	T	Sets hot gas control point %

Available Modes

In "Switches Control" mode, the choices with the "/" require the Mode Switch to be closed. The alternate mode to the right of the "/" will require the mode switch when this mode is the current operating mode.

"BAS Network Control" mode does not need the mode switch to run alternate modes.

Heat makes a unit operate as a Templifier unit and Ice makes the unit run for ice making applications.

Hot Gas (HG) Mode

Water - proportionally opens an HG valve as the ELWT drops below the ELWT setpoint, it is fully open 0.5°F above shutdown ELWT.

RLA - proportionally opens an HG valve as the amps drop below the HG setpoint, the solenoid valve will open in unison with the proportional valve. The valve will close as the %RLA exceeds the setpoint by 5%.

Figure 55: Settings View - Motor

Table 16: Motor Setpoints

Description	Default	Range	PW	Comments
Nominal Capacity	100 tons	0-2000 tons	T	Sets nominal capacity rating of an individual compressor for staging decisions.
Oil No Start Differential	40.0 °F	30 TO 60 °F	M	Compressor Start: Sets minimum delta between oil sump temp and evaporator saturated temp. Oil Heat Control: Sets ON control point @ evaporator LWT + Setpoint + 10F or Sets OFF control point @ evaporator LWT + Setpoint + 20F
Soft Load Enable	Off	Off, On	M	
Initial Soft Load Limit	40%	10 TO 100%	M	Initial %RLA for soft load ramp up
Soft Load Ramp Time	5 min	1 TO 60 min	M	Time period for up to 100% from limit
Show Motor Temps	No	No, Yes	T	Setting for displaying motor temps on HMI screen
Max Leaving Water Temp Rate	0.5 °F/min	0.1 to 5.0 °F/min	M	Sets LWT rate above which capacity increase is inhibited
Min Leaving Water Temp Rate	0.1 °F/min	0.1 to 5.0 °F/min	M	Sets value below which an additional compressor can stage on.
Demand Limit Enable	OFF	ON, OFF	M	ON: Limits %RLA to a value set by the Demand Limit analog input, where: 4 mA = 70 %RLA 20 mA = 100 %RLA OFF: The Demand Limit input is ignored.
Minimum Amps	39%	5 to 80%	M	Sets %RLA below which unloading is inhibited
Maximum Amps	100%	10 to 100%	M	Sets %RLA above which capacity increase is inhibited. Unloading is forced at 5% above this value.
VFD Enable	No	Yes	M	Sets if the motor is controlled by a VFD
VFD Speed Offset	10%	0 to 20%	M	
VFD Minimum Speed	55%	0 to 100%	M	Minimum that can be set is VFD Low Speed Limit
VFD Speed	10%	0 to 100%	M	Sets speed portion of Speed/Lift ratio setpoint where Speed is at 0 Lift.
Lift	90 °F	30 to 90 °F	M	Sets lift portion of Speed/Lift ratio setpoint where Lift is at 100% Speed.
Protocol Starter	Local	Local, Remote, MODBUS, D3, MX3, Iso-Mtr-T MX_MV	T	Communication protocol with compressor starters
Ident Number Starter	1	0-200	T	Identification numbers for starters
Baud Rate Starter	19200	1200, 2400, 48, 00, 9600, 19200	T	

Table 17: Tower Setpoint Settings

Description	Default	Range	PW	Comments
Valve Position (Bypass)	100%			
Valve Control Slope Gain	1	0 to 99	T	Control gain for temperature (or lift) slope
Valve Control Error Gain	20	0 to 99	T	Control gain for temperature (or lift) error
Valve Control Range (Max)	100%	0 to 100%	T	Maximum valve position, overrides all other settings
Valve Control Range (Min)	10%	0 to 100%	T	Minimum valve position, overrides all other settings
Temp–Max. Start Position	90 °F	0 to 100 °F	T	Condenser EWT at which initial valve position is set to max start position
Maximum Start Position	100%	0 to 100%	T	Initial valve position when condenser EWT is at or above Temp-Max Start Position
Temp – Min. Start Position	60 °F	0 to 100 °F	T	Condenser EWT at which initial valve position is set to setpoint Stage Up @
Minimum Start Position	10%	0 to 100%	T	Minimum position of valve when condenser EWT is at or below setpoint Stage Down
Valve Deadband (Lift)	1.0 psi	0 to 20.0 psi	T	Sets control deadband, Cooling Tower Control =Lift
Valve Deadband (Temp)	1.0 °F	0 to 10.0 °F	T	Sets control deadband, Cooling Tower Control =Temp
Valve Target (Lift)	30 psi	1 to 100 psi	T	Target for lift pressure (Cooling Tower Control = Lift), Works with Fan Stage Down Time
Valve Target (Temp)	65 °F	40 to 120 °F	T	Target for condenser EWT (Cooling Tower Control = Temp), Works with Fan Stage Up Time
VFD Stage Down @	20%	0 to 100%	T	Valve position below which the fans can stage down (Tower Valve/Fan VFD Strategy = Valve Stage) VFD speed below which the fans can stage down (Tower Valve/Fan VFD Strategy = VFD stage or valve SP/VFD stage)
VFD Stage Up @	80%	0 to 100%	T	Valve position above which the fans can stage up (Tower Valve/Fan VFD Strategy = Valve Stage) VFD speed above which the fans can stage up (Tower Valve/Fan VFD Strategy = VFD or valve SP/VFD stage)
Cooling Tower Control	None	None, Temperature, Lift	T	None: No tower control Temperature: Fan and valve controlled by condenser EWT Lift: Controlled by lift pressure
Tower Valve/Fan VFD Strategy	None	None, Valve SP, Valve Stage, VFD Stage, Valve SP/VFD Stage	T	None: No tower valve or VFD Valve Setpoint: Valve controls to Valve Target and Valve Deadband Valve Stage: Valve controls between fan stages VFD Stage: 1st fan is VFD controlled, no valve Valve SP/VFD Stage: Both valve and VFD
Tower Valve Type	NC (To Tower)	NC, NO	T	Normally closed or normally open to tower
Cooling Tower Stages	2	1 to 4	T	Number of fan stages used
Fan Stage Up Time	2 min	1 to 60 min	T	Time delay between stage up/down event and next stage up
Fan Stage Down Time	5 min	1 to 60 min	T	Time delay between stage up/down event and next stage down
Stage #4 On (Lift)	65 psi	10 to 130 psi	T	Lift pressure for fan stage #4 on
Stage #3 On (Lift)	55 psi	10 to 130 psi	T	Lift pressure for fan stage #3 on
Stage #2 On (Lift)	45 psi	10 to 130 psi	T	Lift pressure for fan stage #2 on
Stage #1 On (Lift)	35 psi	10 to 130 psi	T	Lift pressure for fan stage #1 on
Stage Differential (Lift)	6.0 psi	1.0 to 20.0 psi	T	Fan staging deadband with Cooling Tower Control=Lift
Stage #4 On (Temp)	85 °F	40 to 120 °F	T	Temperature for fan stage #4 on
Stage #3 On (Temp)	80 °F	40 to 120 °F	T	Temperature for fan stage #3 on
Stage #2 On (Temp)	75 °F	40 to 120 °F	T	Temperature for fan stage #2 on
Stage #1 On (Temp)	70 °F	40 to 120 °F	T	Temperature for fan stage #1 on
Stage Differential (Temp)	3.0 °F	1.0 to 10.0 °F	T	Fan staging deadband with Cooling Tower Control=Temp

Figure 56: Settings View - Tower

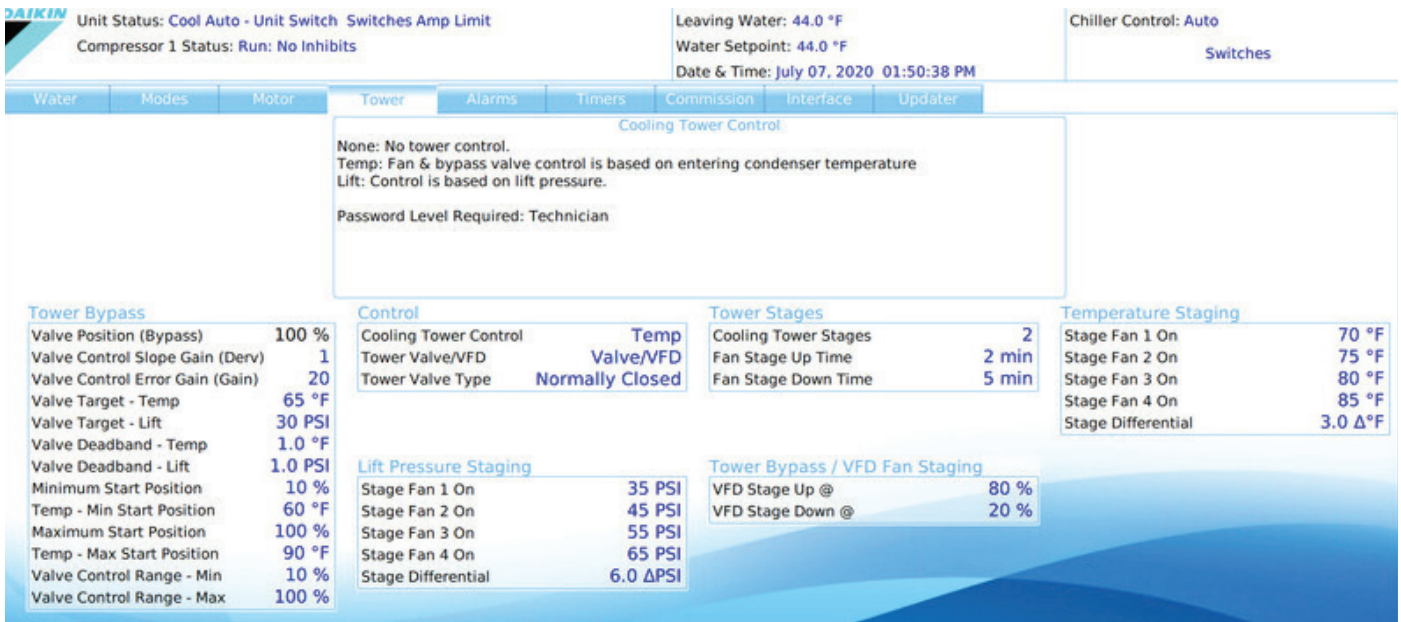

Tower Control Settings

There are five possible tower control strategies: (I) **VFD STAGE**, (II) **VALVE SP**, (III) **VALVE STAGE**, (IV) **NONE**, and (V) **VALVE SP / VFD STAGE**. These control strategies are selected from the TOWER Setpoint Screen (see Table 17 on page 50) using the Tower Valve/Fan VFD Strategy setting. (In the following pages, “SP” means “Setpoint.”) An explanation of each control strategy follows this paragraph. Along with each explanation is a diagram and graph to help illustrate the control strategy. Note that these graphs illustrate the default conditions for each strategy.

Setting Tower Control Using the HMI Panel

MicroTech® may assist in the head control either directly or through inputs to a BAS to optimize performance and efficiency. Using the MicroTech® controller, up to three Digital Outputs of Tower Staging along with two Analog Outputs (0-10 VDC) are available. The two Analog Outputs are as follows:

1. Bypass Valve signal
2. Tower Fan VFD signal

Setup for any tower control will be accomplished on the HMI using the TOWER Setpoint Screen (see Table 17 on page 50 and see Table 17 on page 50).

Setpoint for Cooling Tower Control on the TOWER Setpoint Screen sets the type of control. NONE is selected as default. Choose TEMPERATURE for entering condenser water control or LIFT to define the lift pressure between the Evaporator Pressure and the Condenser Pressure.

Setpoint for Tower Valve / Fan VFD Strategy on the TOWER Setpoint Screen defines if and how the two MicroTech® Analog Outputs (Bypass Valve signal and Tower Fan VFD signal)

will be used with the Staging selected for the tower. A BAS or other control may monitor these outputs to understand when or how much the MicroTech® would recommend for proper head control on the WSC unit. Setup instructions for each of the five tower control strategies are provided next.

Setpoint 3 (Cooling Tower Stages) on the TOWER Setpoint Screen sets the number of tower stages that the tower has.

Strategy (I) VFD STAGE (Default):

In this mode, a VFD controls the first fan. Up to two more fans are staged on and off and there is no bypass valve. See Figure 57 and Figure 58.

To set up in HMI,

- A. The TOWER Setpoint setting for Cooling Tower Control strategy should be NONE. Tower Valve/VFD should be changed to VFD STAGE for control of the VFD speed based on temperature or lift.

Figure 57: Strategy (I) - VFD STAGE

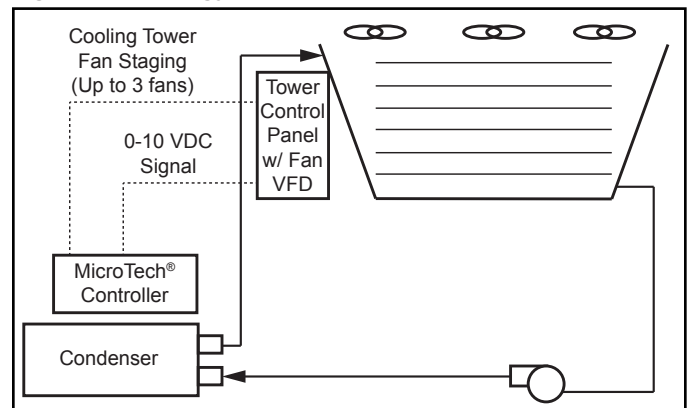
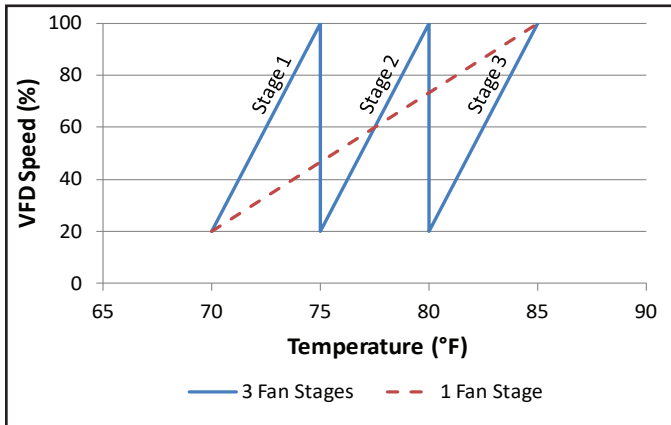

Figure 58: Strategy (I) VFD STAGE - VFD Speed vs. Temp



As shown in Figure 58, the default minimum and maximum VFD speeds are 20% and 100%, respectively. These minimum and maximum values are adjustable anywhere between 0% and 100%. Additional fans stage on when the VFD speed reaches the maximum value that was set.

Strategy (II) VALVE SP:

This control strategy is tower staging (up to three stages) with a low-limit controlled bypass valve. The tower fans are controlled as in method (I), plus a tower bypass valve is controlled to provide a minimum condenser EWT. There is no interconnection between the fan control and the valve control. See Figure 59 and Figure 60.

To set up in HMI,

- A. The TOWER Setpoint setting for Cooling Tower Control strategy should be NONE. Tower Valve/VFD should be changed to VALVE SP for control of the bypass valve based on temperature or lift.
 - Tower Valve Type. Select NC or NO depending if valve is normally closed to the tower with no control power or normally open to the tower with no control power.
- B. If TEMP was selected for Cooling Tower Control, set the Valve Target Temperature - default is 65°F. This setpoint is usually 5°F below the minimum fan stage setpoint established with Stage #1 setting. This keeps full flow through the tower until the last fan is staged off. Other settings when TEMP is selected:
 1. Set Valve Deadband - Temp. The default of 1.0°F is a good place to start.
 2. Set the Valve Control Range to the minimum position to which the valve can go. The default is 10%.
 3. Set the Valve Control Range to the maximum position to which the valve can go. The default is 100%.
 4. Set the Valve Control Error Gain. The default is 20.
 5. Set the Valve Control Slope Gain. The default is 1.
- F. If LIFT was selected for Cooling Tower Control, set the Valve Target - Lift; default is 30 psi. This setpoint is usually 5 psi below the minimum fan stage setpoint established by Stage #1 On (Lift) setpoint. This keeps full

flow through the tower until the last fan is staged off.

7. Set Valve Deadband - Lift. The default of 1.0 psi is a recommended initial setting.
8. Set the Valve Control Range to the minimum position to which the valve can go. The default is 10%.
9. Set the Valve Control Range to the maximum position to which the valve can go. The default is 100%.
10. Set the Valve Control Error Gain. The default is 20.
11. Set the Valve Control Slope Gain. The default is 1.

⚠ CAUTION

Valve Control Error Gain and Slope Gain setpoints are site specific, dealing with system fluid mass, component size, and other factors affecting the reaction of the system to control inputs. To avoid possible equipment damage, these setpoints should be set by personnel experienced with setting up this type of control.

Figure 59: Strategy (II) - VALVE SP

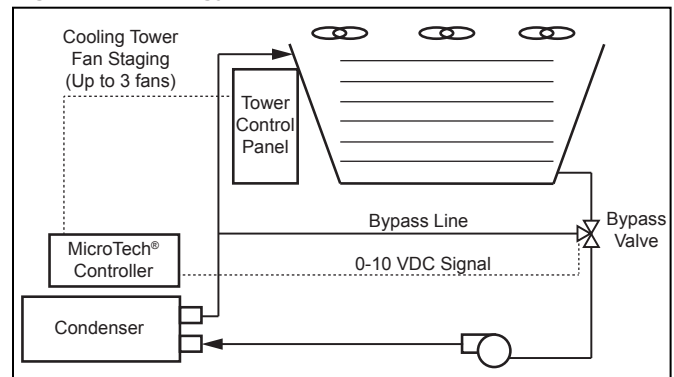
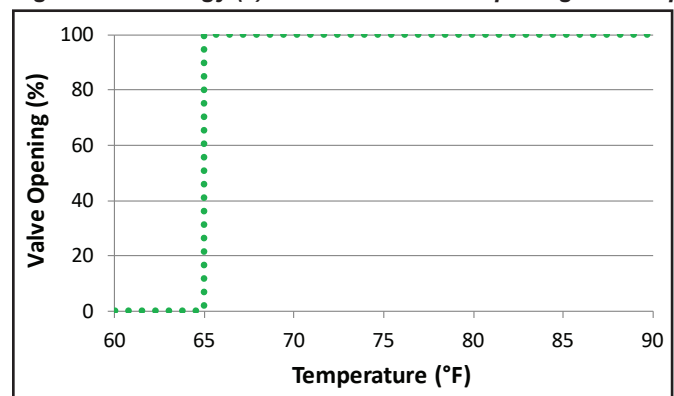

Figure 60: Strategy (II) VALVE SP - Valve Opening vs. Temp



As shown in Figure 60, the default temperature at which the valve opens completely is 65°F. This temperature is the Valve SP (also called Valve Target) and is adjustable.

Strategy (III) VALVE STAGE:

This control strategy is tower staging (up to three stages) with a stage-controlled bypass valve. In this mode, the bypass valve controls between fan stages to smooth the control and reduce fan cycling. See Figure 61 and Figure 62.

To set up in HMI,

- A. The TOWER Setpoint setting for Cooling Tower Control strategy should be NONE. Tower Valve/VFD should be changed to VALVE STAGE.

Tower Valve Type. Select NC or NO depending if valve is normally closed to the tower with no control power or normally open to the tower with no control power.
- B. Use all of the same setpoint settings as outlined in Strategy (II) - section B for Temp or section C for Lift. In addition, set the following:
 - a. Set VFD Stage Up (valve position % open) above which the first fan can stage on; the default is 80%. Fan Stage #X On temperatures and Fan Stage Up Time must also be satisfied.
 - b. Set Stage Down (valve position % closed) below which the first fan can stage off; the default is 20%. Fan Stage #X On temperature and Fan Stage Down Time must also be satisfied.

Figure 61: Strategy (III) - VALVE STAGE

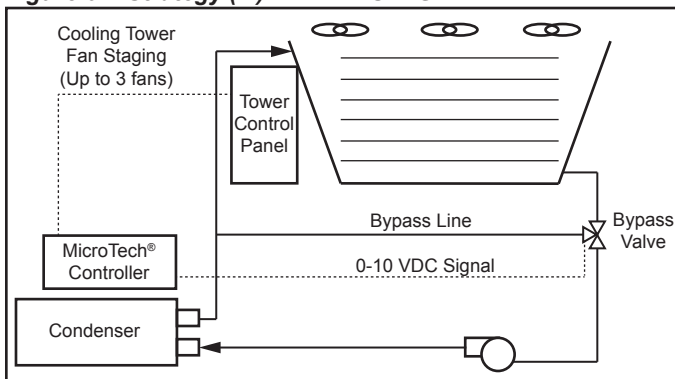
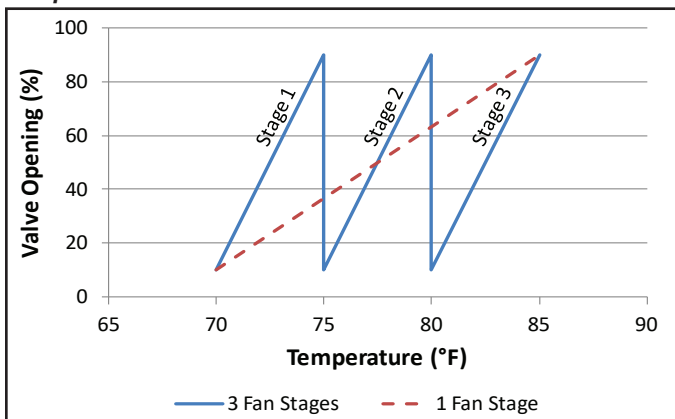

Figure 62: Strategy (III) VALVE STAGE - Valve Opening vs. Temperature



As shown in Figure 62, the default minimum and maximum valve opening positions are 10% and 90%, respectively. These minimum and maximum positions are adjustable anywhere between 0% and 100%. Additional fans stage on when the valve opening position reaches the maximum value that was set.

Strategy (IV) NONE:

This control strategy is tower fan staging only. **This is not a recommended strategy.** In this mode the tower fan staging (up to three stages) is controlled by either the condenser Entering Water Temperature (EWT) or LIFT pressure (difference between the condenser and evaporator pressure). Tower bypass or fan speed are not controlled. See Figure 63 and Figure 64.

To set up in HMI,

The following settings are used for the Tower Fan Staging Only mode:

1. Select TEMP if Cooling Tower Control is based on condenser EWT or LIFT if based on compressor lift expressed in pressure.
2. Set Tower Valve/VFD as NONE for no bypass valve or fan VFD control.
3. Set Cooling Tower Stages as one to three fan outputs depending on the number of fan stages to be used. More than one fan can be used per stage through the use of relays.
4. Select Fan Stage Up Time from 1 to 60 minutes. The default value of 2 minutes is a good starting point. The value may need to be adjusted later depending on actual system operation.
5. Select Fan Stage Down Time from 1 to 60 minutes. The default value of 5 minutes is a good starting point. The value may need to be adjusted later depending on actual system operation.

If TEMP is selected for Cooling Tower Control, use:

- a. Set Stage Differential in degrees F; default is 3°F.
- b. Set the Stage Fan On temperatures consistent with the temperature range over which the condenser EWT is desired to operate. The default values of 70°F, 75°F, and 80°F are a good place to start in climates with moderate wet bulb temperatures. The number of Stage Fan On setpoints used must be the same as the number of Cooling Tower Stages.

If LIFT is selected for Cooling Tower Control, use

- a. Set Stage Differential in PSI; default is 6.0 PSI.
- b. Set the Stage Fan On pressures starting with default setpoints. The number of Stage Fan On setpoints used must be the same as the number of Cooling Tower Stages.

Figure 63: Strategy (IV) - NONE

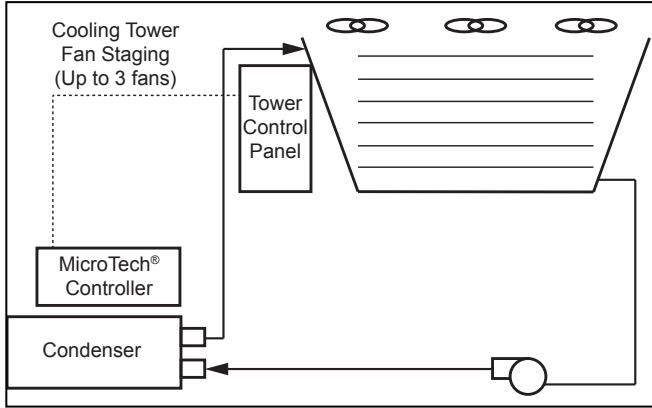
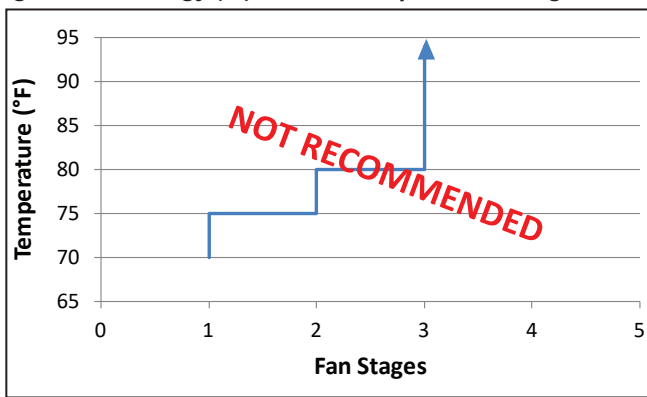

Figure 64: Strategy (IV) NONE - Temp vs. Fan Stages



Strategy (V) VALVE SP /VFD STAGE:

This control strategy is tower fan control with a VFD and bypass valve control. See Figure 65 and Figure 66.

To set up in HMI, do the following:

- A. The TOWER Setpoint setting for Cooling Tower Control strategy should be NONE. Tower Valve/VFD should be changed to VALVE SP/VFD STAGE.
- B. Use all of the same setpoint settings as outlined in Strategy (II) - section B for Temp or section C for Lift. .

Figure 65: Strategy (V) - VALVE SP/VFD STAGE

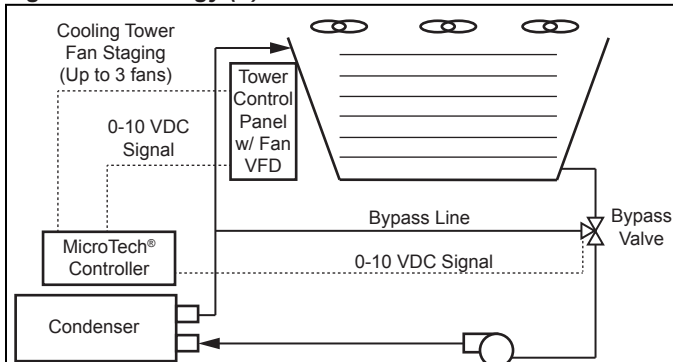
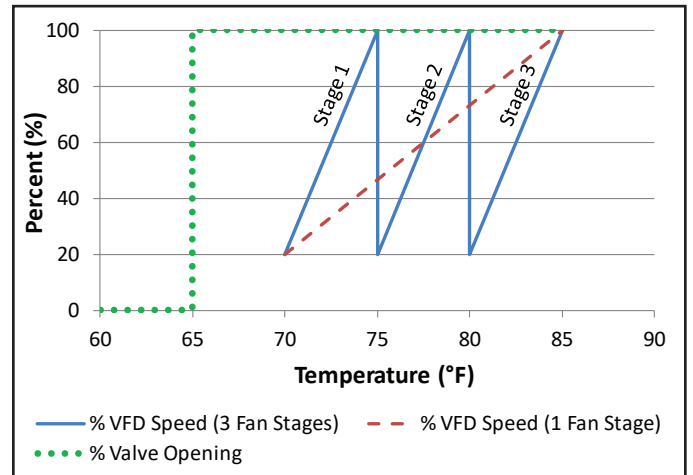

Figure 66: Strategy (V) VALVE SP / VFD STAGE - Percent vs. Temperature



As shown in Figure 66, the default minimum and maximum VFD speeds are 20% and 100%, respectively. These minimum and maximum values are adjustable anywhere between 0% and 100%. Additional fans stage on when the VFD speed reaches the maximum value that was set. In addition, Figure 66 shows that the default temperature at which the valve opens completely is 65°F. This temperature is the Valve SP (also called Valve Target) and is adjustable.

BAS Alternate

In control strategies (I) through (V), the chiller MicroTech® is directly controlling the cooling tower fan staging, variable frequency drives, and bypass valves. As an alternative, a BAS can control these components based on a signal from the MicroTech® controller. See Figure 67.

Figure 67: BAS Alternate

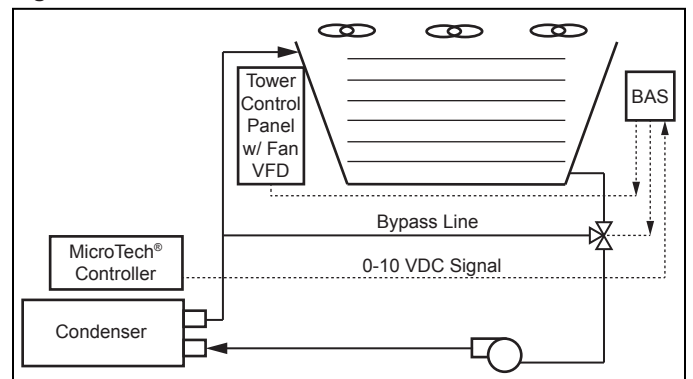

Figure 68: Settings View - Alarms

Unit Status: Cool Auto - Unit Switch Switches Amp Limit
 Compressor 1 Status: Run: No Inhibits
 Leaving Water: 44.0 °F
 Water Setpoint: 44.0 °F
 Date & Time: July 07, 2020 01:50:55 PM
 Chiller Control: Auto
 Switches

Water Modes Motor Tower **Alarms** Timers Commission Interface Updater

Low Suction Pressure - Inhibit
 Sets the suction pressure value below which any capacity increase is inhibited.
 Minimum: 7.0 °F
 Maximum: 45.0 °F
 Password Level Required: Technician

Low Suction Pressure
 Low Suction Pressure - Inhibit 33 PSI
 Low Suction Pressure - Unload 31 PSI
 Low Suction Pressure - Stop 29 PSI

High Condenser
 High Condenser Pressure 140 PSI
 High Discharge Temp - Load 170 °F
 High Discharge Temp - Stop 190 °F

Surge Limit
 Surge Temp Limit 6 °F
 Surge Slope Limit 20 °F/Min

Motor Current Threshold
 Motor Current Threshold 10 %

Freeze Protect
 Evaporator Freeze Protect 34.0 °F
 Condenser Freeze Protect 34.0 °F

Water Flow
 Lenient Flow Sensing Off

Oil
 High Oil Feed Temp 140 °F
 Low Oil Delta Temp 30 Δ°F
 Low Net Oil Pressure 50 PSI

Table 18: ALARMS Setpoint Settings

Description	Default	Range	PW	Comments
Condenser Freeze Protect	34.0 °F	-9.0 to 45.0 °F	T	Sets the value of condenser saturated temperature below which the condenser pump is forced ON - occurs when unit is off and chiller senses need to provide flow to address a chiller limit alarm - see "Table 24: Warning Alarms and Informative Messages" on page 61
Evaporator Freeze Protect	34.0 °F	-9.0 to 45.0 °F	T	Sets the value of evaporator saturated temperature below which the evaporator pump is forced ON - occurs when unit is off and chiller senses need to provide flow to address a chiller limit alarm - see "Table 24: Warning Alarms and Informative Messages" on page 61.
High Condenser Pressure	140 psi	120 to 270 psi	T	Sets the condenser pressure above which the compressor is shut down.
High Discharge Temp - Load	170 °F	120 to 240 °F	T	Discharge temp above which a forced capacity increase occurs.
High Discharge Temp - Stop	190 °F	120 to 240 °F	T	Discharge temp above which the compressor is shut down.
Low Suction Pressure - Inhibit	33 psi	7 to 45 psi	T	Sets the evaporator pressure value below which any capacity increase is inhibited - may need to be lowered if glycol is added to the system. Similarly, changing setpoint below 30 psi default requires glycol to be added to the system otherwise there is a risk of freezing the evaporator.
Low Suction Pressure - Unload	31 psi	6 to 45 psi	T	Suction pressure value below which a forced capacity decrease occurs.
Low Suction Pressure - Stop	29 psi	5 to 45 psi	T	Suction pressure value below which compressor is shut down.
Motor Current Threshold	10%	3 to 99%	T	When % RLA is below setpoint, motor is considered OFF.
Surge Temp Limit	6 °F	2 to 25 °F	T	Surge Temp (ST) = Suction Temp - Evap Leaving Temp, ST is compared to SP. If LESS, alarm occurs when ST > 2x setpoint. If MORE, slope alarm is active until ST < this setpoint, then alarm at 2x setpoint.
Surge Slope Limit	20 °F/min	1 to 99 °F/min	T	Sets Surge Temp Slope above which alarm occurs.
Lenient Flow Sensing	Off	Off, On	T	When ON, allows the chiller to run without flow as long as the unit does not approach an alarm. When OFF, a trip timer for each vessel will determine timing allowed before issuing a flow loss alarm.
High Oil Feed Temp	140 °F	120 to 240 °F	T	Above limit, compressor shuts down.
Low Oil Delta Temp	30 °F	20 to 80 °F	T	Delta Temp (above evaporator saturated temp); If value is below setpoint, compressor shuts down.
Low Net Oil Pressure	50 psi	0 to 90 psi	T	Net Oil Pressure (Feed pressure - sump pressure); If value is below setpoint, compressor shuts down.

Figure 69: Settings View - Timers

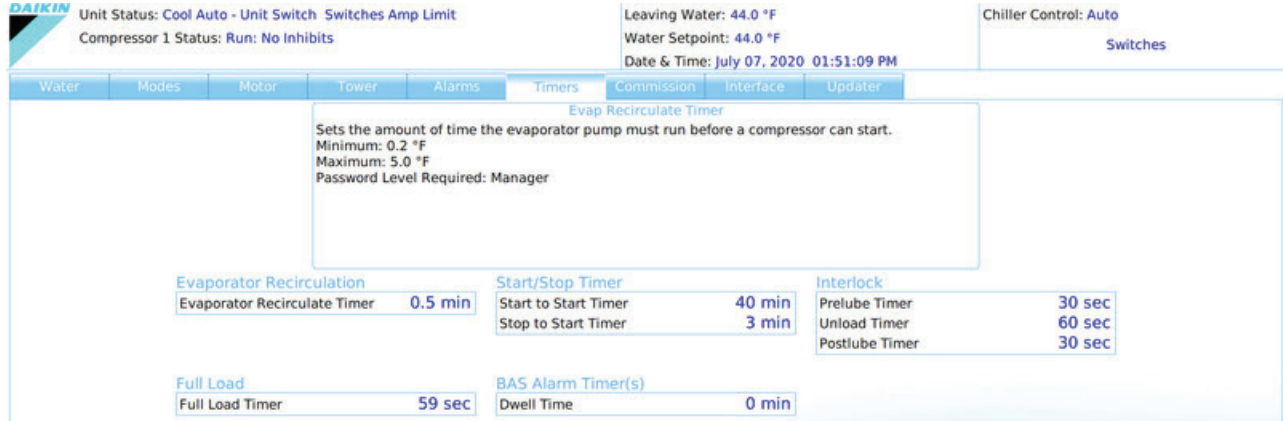

Table 19: Timer Settings

Description	Default	Range	Password	Comments
Evap Recirculate	0.5 min	0.2 - 5 min	M	Time that evaporator pump must run before compressor start
Full Load Timer	59 sec	0 to 999 sec	T	Time compressor must load (without unloading) before vanes are considered fully open.
Start to Start Timer	40 min	2 to 60 min	M	Time required from a start to the next start
Stop to Start Timer	3 min	1 to 20 min	M	Time required from a stop to the next start
Dwell Time	0 min	0 to 99 min	T	Delay Time Alarms are passed to BAS to allow time for chiller to reset before disabled by BAS.
Prelube Timer	30 sec	10 to 240 sec	T	
Unload Timer	60 sec	5 to 300 sec	T	
Postlube Timer	30 sec	10 to 240 sec	T	

Figure 70: Settings View - Commission



Table 20: Unit Commissioning Settings

Description	Default	Range	PW	Comments
Heat Recovery Usage	Disabled	Disabled, Enabled	M	Allows for Heat Recovery data and alarms to be displayed...see Figure 71

Once Heat Recovery Usage has been enabled in the Settings View - Commission tab, the temperatures related to the auxiliary heat recovery bundle will be shown on the Unit Home screen as shown in Figure 71.

Figure 71: Heat Recovery on Home Screen

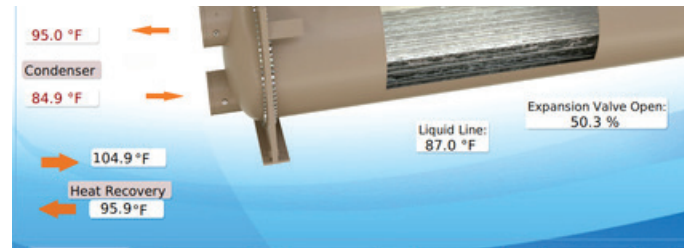

Table 21: Settings View - Interface

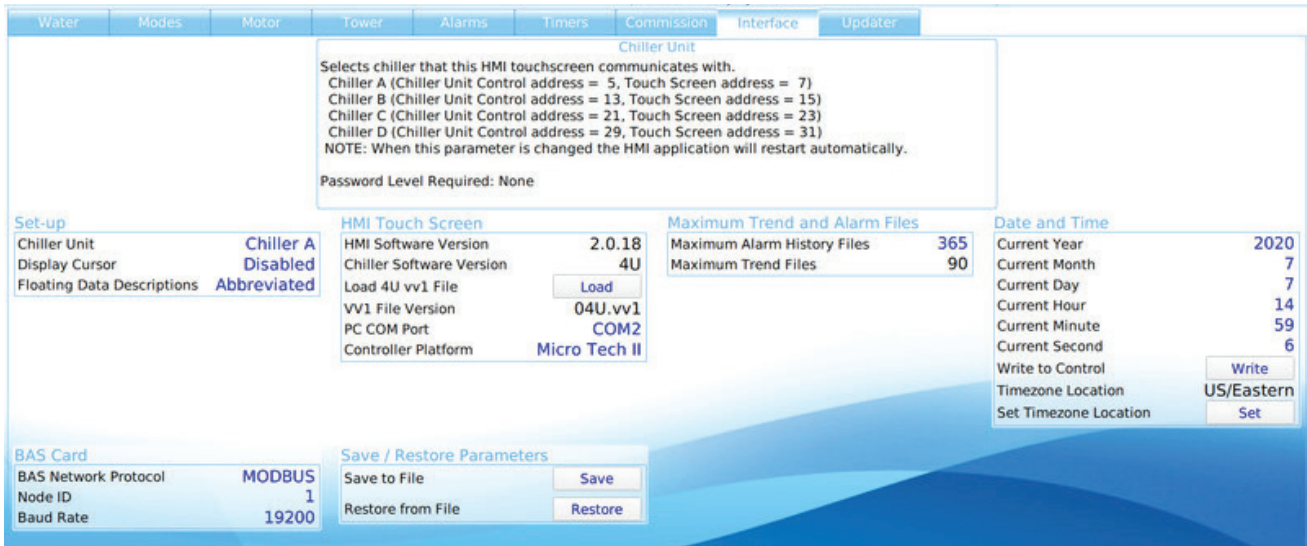
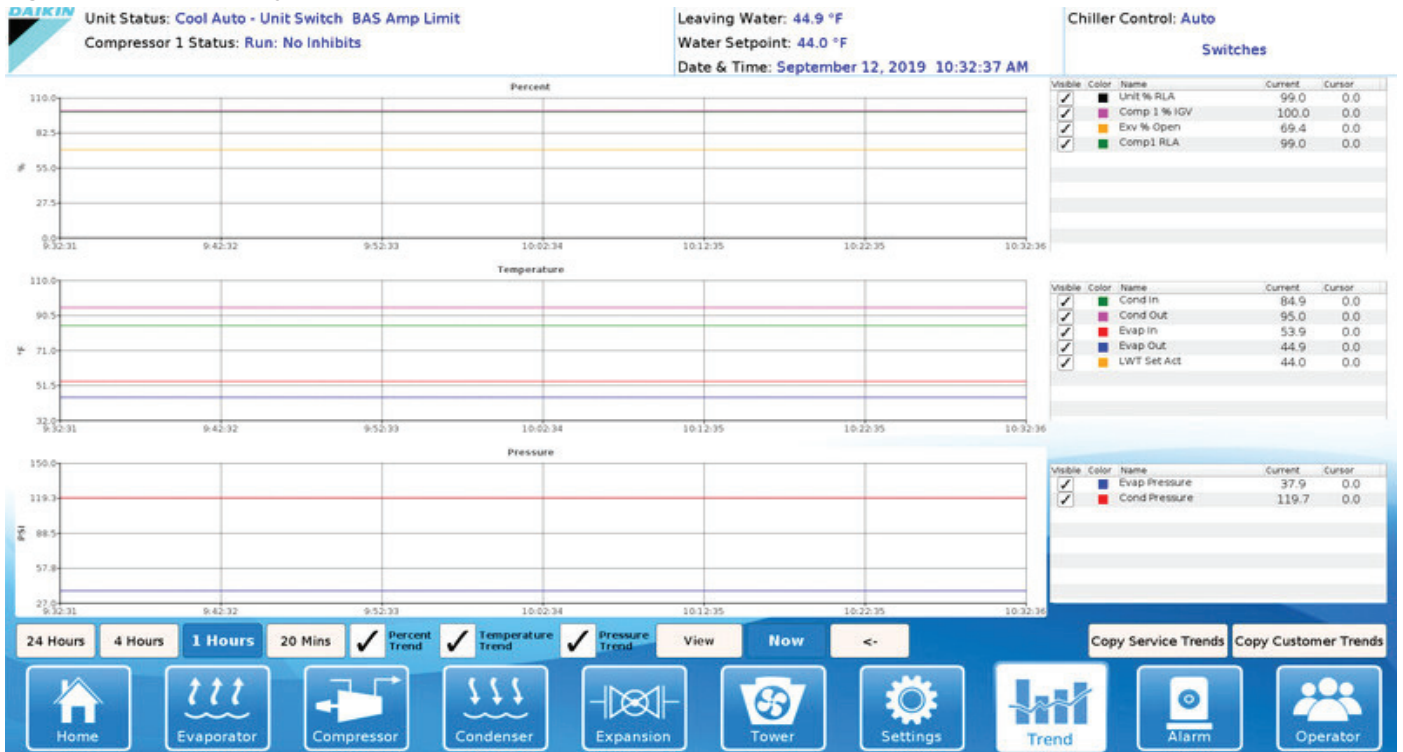

Table 22: Unit Interface Settings

Description	Default	Range	PW	Comments
BAS Network Protocol	NONE	NONE, Local, Remote, MODBUS, LONWORKS, BACnet IP, BACnet Ethernet, BACnet MS/TP	M	NONE: No BAS network; MODBUS: RTU - RS485; LONWORKS: LONtalk - FTT-10A; BACnet IP: IP - Ethernet; BACnet Ethernet: Ethernet; BACnet MS/TP: RS485

NOTE: It is likely that the chiller will contain the factory settings for date and time; therefore, it is important to verify or change these settings when the chiller is first used on the job-site. Failure to do so will result in incorrectly labeled History files. The version numbers shown are the controllers' software identification. These numbers may be required by Daikin Applied to answer questions about unit operation or to assist in possible future upgrades of software.

Figure 72: Trend History Screen



Trend History Screen

The Trend History Screen (Figure 72) is accessed by clicking the TREND button at the bottom of any screen. The Trend History Screen allows the user to view the various parameters listed on the right side of the screen.

The Trend History Screen can display history for 24-hour, 4-hour, 1-hour, or 15-minute periods by pressing the appropriate button, respectively. For any time period, the trend will display the current time beginning on the right of the screen with history flowing to the left.

When the Unit Control Processor is powered on after being off, the Trend History Screen will only display the history starting from the time the Unit Control Processor was powered on. Previous trend history can be downloaded but there will be a gap in the data from when the Unit Control Processor was off. Trend history is not affected if only the HMI screen (not the Unit Control Processor) is off or in sleep mode. For details on how to download the trend history, reference the "Alarms" section.

Alarms

The Alarm information (Figure 73 and Figure 74) is accessed by touching the ALARM icon at the bottom of the HMI and then the Active or History tabs at the top of the screen. As noted on page 39, an active alarm will turn the icon flashing red.

There are three types of entries in the table:

- 1. **Critical Alarm (Red Text)** - This is an equipment protection alarm that will shut a unit or compressor off if not corrected.
- 2. **Warning (Yellow Text)** - This alarm limits compressor loading in response to an out-of-normal condition or may only be a notification to indicate that the condition requires attention. This alarm may not cause a shutdown. If the condition that caused a warning is corrected, the alarm light will be cleared automatically.
- 3. **Informational (Black Text)** - This notification type reports actions the unit may be taking while trying avoid a warning or critical alarm.

The Alarm Active and History Screens display a maximum of

18 alarms for the current date with the most current alarms listed on top. Each alarm displays the date stamp, action taken, and the cause of the alarm. See the Alarm tables starting on page 60 for specifics on alarms that may occur. Alarm history data is held for 365 days as shown on the Interface tab in Table 21.

Clearing an Alarm

There are two different indicators that the chiller will generate when conditions arise that are affecting the chiller operations. Warnings are indicated in yellow text on the HMI and communicate that the chiller should be serviced but allow the chiller to keep running. Warnings cannot be cleared manually and will be cleared automatically when the issues has been resolved.

Critical Alarms will always shutoff the chiller. Critical Alarms that do not require external intervention may attempt to auto-clear once conditions return to normal (Pressure and Temperature Alarms). Auto-cleared Critical Alarms will become yellow and will be displayed as warnings unless there has been 3 within the hour. After 3 alarms occur within the hour, the Critical Alarm will be displayed as a Critical Alarm by being indicated in Red on the HMI and will prevent the chiller from running until manually cleared at the HMI or via the BAS. Critical Alarms that require external intervention (Communication and Sensor Alarms) will immediately show up as Red Alarms on the HMI and prevent the chiller from running until manually cleared at the HMI or via the BAS, after the condition has been resolved.

Repeated manual clearing of Critical Alarms via the HMI or the BAS without resolving the cause of the Alarm may damage the chiller and void the chiller warranty.

Although the Alarm History Screen only displays the most current alarms, a record of ALL alarms is stored in the Unit Control Processor. Note that this record may include alarms that occurred when the chiller was not yet fully assembled in the factory. This record is maintained even if the Unit Control Processor is powered off. When the HMI is powered back on, the last 18 alarms for the current date will show on the Alarm History Screen and all alarm history will still be available for download.

Figure 73: Active Alarm View Screen

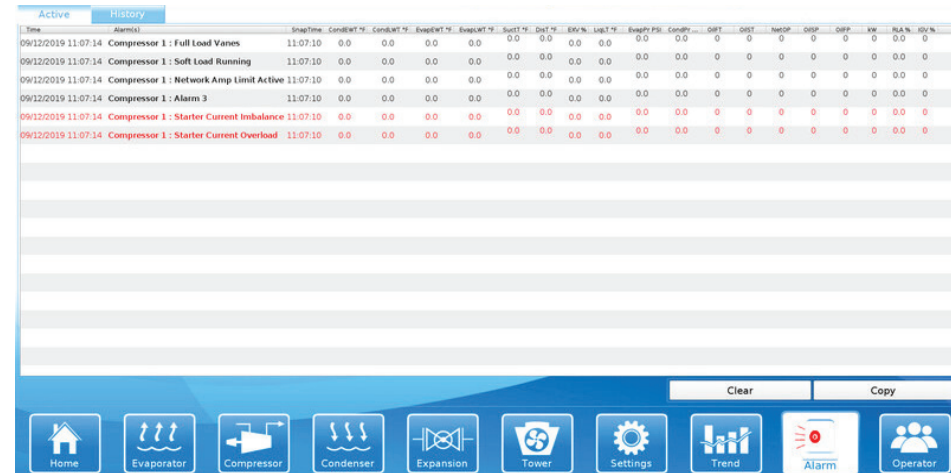

Figure 74: Alarm History Screen

Time	Alarm(s)	SnapTime	CondEWT °F	CondLWT °F	EvapEWT °F	EvapLWT °F	SuctT °F	Dist °F	EXV %	LiqLT °F	EvapPr PSI	CondPr PSI	Min RPM	Act RPM	Max RPM	Dem %	DemFB	kW	RLA %	IGV %
10/11/2017 10:56:20	Compressor 1 : Starter Fault	10:56:16	98.0	105.9	49.8	42.6	45.7	125.1	86.6	103.4	32.0	136.8	19440	19008	20183	87.3	843.0	126	104.0	110
10/11/2017 09:28:54	Compressor 1 : Starter Fault	09:28:50	102.9	108.5	48.7	42.0	44.5	125.3	83.7	106.8	32.8	134.6	19060	18918	19921	87.3	824.0	123	102.0	110
10/11/2017 09:14:09	Compressor 1 : Starter Fault	09:14:05	100.2	107.7	49.6	42.8	44.9	131.5	85.7	105.4	32.1	148.1	19885	19228	20579	61.4	694.0	129	108.0	100
10/11/2017 07:06:15	Compressor 1 : Motor High Temperature	07:06:11	55.4	57.7	59.9	57.2	46.4	127.4	0.0	55.0	33.1	146.1	19462	19460	20194	69.8	710.0	129	110.0	84
							44.7	128.4			33.6	141.5	19703	19004	20345	91.4	871.0	124	103.0	110
							58.8	68.5			49.0	138.8	19329	19473	20102	0.0	920.0	129	108.0	85
							84.2	90.0			50.5	49.1	4004	0	13676	0.0	0.0	0	0.0	0

Downloading Trend and Alarm History

The Copy button on the Trend History and Alarm History screens can be used to download the data via USB. In order to download the trend and alarm history:

1. Insert a USB drive into the left side of the HMI panel or directly into embedded HMI PC.
- NOTE:** Thirty MB per day should be available on the USB drive that is inserted for the download of the trend and alarm history. There is no warning of insufficient space.
2. If an error message that states “Error mounting the USB drive” appears on the HMI, remove and re-install the USB drive. If the problem persists, try a different USB drive. Name brand USB drives are recommended.
- NOTE:** Often times, this error message is due to not allowing sufficient time between inserting the USB drive and pressing the Copy button (see Step 4 below).
3. After clicking on the “Display Date” button, choose the desired date.
 4. Press the Copy button. This will download the trend and alarm history for the selected day. (The Unit Control Processor will store 30 days of history at a maximum. The Unit Control Processor will automatically delete old trend history files as needed to make room for new trend history files. Old alarm history files are not deleted.) The HMI will display “download complete” once the history files have been successfully transferred to the USB drive. “Copy Service Trends” is only available with the technician level password. “Copy Customer Trends” is available for all password levels.

5. Repeat this process for each desired day of history. Each day must be downloaded individually. It is not possible to download multiple days of history at once.

Viewing/Using Trend History Files:

Trend history files can be recognized by “Trend” at the beginning of the file name followed by the date. For example, if there is a file called “Trend20180623.csv,” it indicates that the file contains trend history from 6/23/2018. If the history is downloaded for the current day, there will only be trend history file up to the current hour. No trend history file is created when the chiller is powered off.

Viewing/Using Alarm History Files:

Alarm history files can be recognized by “AlarmHistory” at the beginning of the file name followed by the date. For example, if there is a file called “AlarmHistory20180623.csv,” it indicates that the file contains alarm history from 6/23/2018. When the history is downloaded, there will only be one alarm history file per day. This one alarm history file will contain all of the alarms from the selected day. If there were no alarms that day, no alarm history file will appear when the history is downloaded.

All alarm history files are saved from the Unit Control Processor as .csv files. These files can be opened on a normal PC and manipulated using a spreadsheet program.

Requesting Tech Support:

If tech support is requested, ALL of the original, un-manipulated files (Trend.csv and AlarmHistory.csv,) must be sent together to Daikin Applied. Any other file formats are NOT accepted.

Table 23: Critical Alarms

Screen Text	Action Taken	Troubleshooting	Clear
Evaporator Pressure Low	Rapid Stop	Low or No Evaporator Water Flow. Low refrigerant level in evaporator. Incorrect setpoint value for leaving water temperature.	Manual
Discharge Pressure High	Rapid Stop	Low or no condenser water Flow	Manual
Vanes Not Closed	Rapid Stop		Manual
Oil Pressure Low	Rapid Stop		Manual
Oil Feed Temperature Low	Rapid Stop		Manual
Oil Feed Temperature High	Rapid Stop		Manual
RLA Low (motor open)	Rapid Stop		Manual
Discharge Temperature High	Rapid Stop	Low or no condenser water Flow	Manual
High Pressure Switch	Rapid Stop		Manual
Motor Temperature High	Rapid Stop	Rotor and/or stator cooling circuit fault Motor stator cooling solenoid not open, rotor cooling stepper motor not functioning correctly, motor rotor superheat or gain setpoints incorrect (contact factory)	Manual
Surge Detected - Running	Rapid Stop	Surge Temperature = the suction temperature minus the leaving chilled water temperature.	Manual
Surge Condition	Rapid Stop/No Start	Surge condition detected while starting	Manual
No Starter Transition	Rapid Stop/No Start		Manual
Starter Fault	Rapid Stop		Manual
Prelube Cycle Failed	Rapid Stop/No Start	Oil pressure too low to start compressor.	Manual
Evaporator Water Flow Loss	Rapid Stop	Loss of evaporator flow, evaporator pump off, evaporator head gasket leaking or missing, sensor wiring fault, evaporator flow sensor failure	Manual
Condenser Water Flow Loss	Rapid Stop	Loss of condenser flow, condenser pump off, condenser head gasket leaking or missing, sensor wiring fault, condenser flow sensor failure	Manual
Sensor Fault: Evap LWT	Rapid Stop	Sensor shorted or open. Chilled water flow switch may be open	Manual
Sensor Fault: Evap Sat Press	Rapid Stop/No Start	Sensor shorted or open. Check for loose wires or failed sensor	Manual
Sensor Fault: Cond Sat Press	Rapid Stop/No Start	Sensor shorted or open. Check for loose wires or failed sensor	Manual
Sensor Fault: Suction Temp	Rapid Stop/No Start	Sensor shorted or open. Check for loose wires or failed sensor	Manual
Sensor Fault: Discharge Temp	Rapid Stop/No Start	Sensor shorted or open. Check for loose wires or failed sensor	Manual
Sensor Fault: Oil Feed Temp	Rapid Stop/No Start	Sensor shorted or open. Check for loose wires or failed sensor	Manual
Sensor Fault: Oil Sump Temp	Rapid Stop/No Start	Sensor shorted or open. Check for loose wires or failed sensor	Manual
Sensor Fault: Oil Feed Pressure	Rapid Stop/No Start	Sensor shorted or open. Check for loose wires or failed sensor	Manual
Sensor Fault: Oil Vent Pressure	Rapid Stop/No Start	Sensor shorted or open. Check for loose wires or failed sensor	Manual
External Input Comp Fault	Rapid Stop		Manual
Starter Current Overload	Rapid Stop		Manual
Starter Current Imbalance	Rapid Stop		Manual
Starter Phase Loss	Rapid Stop		Manual
Starter Phase Order	Rapid Stop		Manual
Starter Over Volt	Rapid Stop		Manual
Starter Under Volt	Rapid Stop		Manual
Ground Fault	Rapid Stop		Manual
Sensor Fault: Leaving Heat Recovery	Rapid Stop		Manual
External Fault Digital Input	Rapid Stop		Manual
Motor Temperature Trip - NTC	Rapid Stop		Manual
Motor Temperature Trip - DI	Rapid Stop		Manual
IGV Actuator Fault	Rapid Stop		Manual
IGV Position Tracking Error	Rapid Stop		Manual

Table 24: Warning Alarms and Informative Messages

Screen Text	Action Taken	Troubleshooting	Clear
Evaporator Pump #1 Fault	Warning	No flow indicated with Evaporator Pump #1 ON AND [the other pump is available (per the evaporator Pump SP) AND has not faulted]. Check for loose wires or failed sensor	Manual
Evaporator Pump #2 Fault	Warning	No flow indicated with Evaporator Pump #2 ON AND [the other pump is available (per the evaporator Pump SP) AND has not faulted]. Check for loose wires or failed sensor.	Manual
Condenser Pump #1 Fault	Warning	No flow indicated with Condenser Pump #1 ON AND [the other pump is available (per the evaporator Pump SP) AND has not faulted]. Check for loose wires or failed sensor.	Manual
Condenser Pump #2 Fault	Warning	No flow indicated with Condenser Pump #2 ON AND [the other pump is available (per the evaporator Pump SP) AND has not faulted]. Check for loose wires or failed sensor.	Manual
Evaporator Water Freeze	Warning	Evap Sat Refr Temp < Evaporator Freeze SP while unit is not running. Start evap pump and oil pump	Auto
Condenser Water Freeze	Warning	Cond Sat Refr Temp < Condenser Freeze SP while unit is not running. Start cond pump and oil pump	Auto
Hold - Evaporator Pressure Low	Informative Message	Inhibits unloading. Pressure < Low Evap Pressure–Inhibit setpoint	Auto
Unload - Evaporator Pressure Low	Informative Message	Pressure < Low Evap Pressure–Unload setpoint	Auto
Sensor Fault: Liquid Line	Informative Message	Sensor is shorted or open. Check for loose wires or failed sensor. Unit continues to run, performance may be affected	Auto
Sensor Fault: Evap EWT	Informative Message		Auto
Sensor Fault: Cond EWT	Informative Message		Auto
Sensor Fault: Cond LWT	Informative Message		Auto
IGV Sensor Fault	Informative Message		Auto
RLA High (Current)	Informative Message	Unit asked to stop but current still detected.	Auto
Tower Sump Temp Sensor Warning	Informative Message		Auto
Network Amp Limit Active	Informative Message		Auto
Soft Load Running	Informative Message		Auto
Discharge Temperature High (Load)	Informative Message		Auto
Unload Inhibited RLA at Min	Informative Message		Auto
LWT Slope Limit	Informative Message	If Heat Mode, LWT is from condenser	Auto
Evaporator Press Load Inhibit	Informative Message		Auto
Amp Limit No Load	Informative Message		Auto
Evaporator Pressure Unload	Informative Message		Auto
Amp Limit Unload	Informative Message		Auto
VFD at Minimum Speed	Informative Message		Auto
Staging Unload	Informative Message		Auto
Vane Mode	Informative Message		Auto
VFD Mode	Informative Message		Auto
Maximum Amps No Load	Informative Message		Auto
Maximum Amps Unload	Informative Message		Auto
Motor Temperature Unload	Informative Message		Auto
Motor Temperature No Load	Informative Message		Auto
Motor Coolant Loss	Informative Message		Auto
Motor Coolant Capacity-Limited	Informative Message		Auto
Oil Reclaim System Activated	Informative Message		Auto

Controller Inputs and Outputs

As outlined below, inputs and outputs vary between the unit controller and the compressor controller.

Unit Controller Inputs and Outputs

The following tables list the unit controller inputs and outputs, both analog and digital, as well as the stepper motor outputs.

Table 25: Unit Controller, Analog Inputs

Description	Wiring	Source	Signal	Sensor Range ²
Entering Evaporator Water Temperature	Chiller	NTC Thermistor	10k @ 25°C	-40 to 125°C
Leaving Evaporator Water Temperature ¹	Chiller	NTC Thermistor	10k @ 25°C	-40 to 125°C
Entering Condenser Water Temperature	Chiller	NTC Thermistor	10k @ 25°C	-40 to 125°C
Leaving Condenser Water Temperature	Chiller	NTC Thermistor	10k @ 25°C	-40 to 125°C
Liquid Line Refrigerant Temperature	Chiller	NTC Thermistor	10k @ 25°C	-40 to 125°C
Evaporator Water Flow Rate	Field	Water Flow Sensor	4 to 20 mA Current	0 to 10,000 gpm
Condenser Water Flow Rate	Field	Water Flow Sensor	4 to 20 mA Current	0 to 10,000 gpm
Reset of Leaving Water Temperature	Field	BAS	4 to 20 mA Current	0 to 100%
Demand Limit	Field	BAS	4 to 20 mA Current	0 to 100%
Entering Heat Recovery Temp	Chiller	NTC Thermistor	10k @ 25°C	-40 to 125°C
Leaving Heat Recovery Temperature	Chiller	NTC Thermistor	10k @ 25°C	-40 to 125°C

NOTE: 1. Wiring is to the compressor box.

2. "Sensor Range" in Table 25 indicates the range of the input, NOT the operating range of the chiller.

Table 26: Unit Controller, Digital Inputs

Description	Wiring	Signal Source	States (Open / Closed)
Front Panel "Stop/Auto" Unit Switch	Chiller	Isolated Switch Contacts	Stop / Auto
Remote Start/Stop	Field	Isolated Switch or Relay Contacts	Stop / Start
Mode Switch	Chiller	Isolated Switch Contacts	Cool / Ice or Heat

Table 27: Unit Controller, Analog Outputs

Description	Signal	Sensor Range
Cooling Tower Bypass Valve Position	0 to 10 VDC	0 to 100% Open
Cooling Tower VFD Speed	0 to 10 VDC	0 to 100%
Electronic Expansion Valve	0 to 10 VDC	0 to 100% Open

NOTE: "Sensor Range" in Table 27 indicates the range of the output, NOT the operating range of the chiller.

Table 28: Unit Controller, Digital Outputs

Description	Source	Rating
Alarm	Indicator Light	120 VAC
Evaporator Water Pump #1	Pump Contactor	240 VAC
Evaporator Water Pump #2	Pump Contactor	240 VAC
Condenser Water Pump #1	Pump Contactor	240 VAC
Condenser Water Pump #2	Pump Contactor	240 VAC
Cooling Tower Fan #1	Fan Contactor	240 VAC
Cooling Tower Fan #2	Fan Contactor	240 VAC
Cooling Tower Fan #3	Fan Contactor	240 VAC
Cooling Tower Fan #4	Fan Contactor	240 VAC

Compressor Controller Inputs and Outputs

The following tables list analog inputs and digital outputs for the compressor controller as well as the stepper motor outputs.

Table 29: Compressor Controller, Analog Inputs

Description	Source	Signal	Sensor Range
Oil Sump Pressure		0.5 to 4.5 VDC nominal	
Oil Feed Pressure to Compressor		0.5 to 4.5 VDC nominal	
Oil Sump Temperature		10k @ 25°C	-40 to 125°C
Oil Feed Temperature		10k @ 25°C	-40 to 125°C
Compressor Suction Temperature	NTC Thermistor	10k @ 25°C	-40 to 125°C
Compressor Discharge Temperature	NTC Thermistor	10k @ 25°C	-40 to 125°C
Evaporator Suction Refrigerant Pressure	Sealed Gage Transducer	0.5 to 4.5 VDC nominal	0 to 132 psi
Condenser Discharge Refrigerant Pressure	Sealed Gage Transducer	0.5 to 4.5 VDC nominal	0 to 410 psi
Motor Current	Sealed Gage Transducer	0 to 10 VDC nominal	0 TO 200%
Leaving Evaporator Water Temperature	NTC Thermistor	10k @ 25°C	-40 to 125°C

Table 30: Compressor Controller, Digital Inputs

Description	Signal	States (Open / Closed)
Compressor Switch - Manual Off	0 to 24 VAC	Stop / Auto
Mech High Pressure	0 to 24 VAC	High Pressure / Ok
Motor High Temperature	0 to 24 VAC	High Temp / Ok
Vanes Closed Switch	0 to 24 VAC	Not Closed / Closed
Starter Transition	0 to 24 VAC	No Transition / Transition
Starter Fault	0 to 24 VAC	Fault / No Fault
Evaporator Water Flow Switch	0 to 24 VAC	No Flow / Flow
Condenser Water Flow Switch	0 to 24 VAC	No Flow / Flow
Vanes Open Switch	0 to 24 VAC	Not Open / Open

Table 31: Compressor Controller, Analog Outputs

Description	Signal	Sensor Range
Compressor VFD Speed	0 to 10 VDC	0 to 100%
Oil Cooler Electronic Valve	0 to 10 VDC	0 to 100%
Hot Gas Bypass	0 to 10 VDC	0 to 100%

Table 32: Compressor Controller, Digital Outputs

Description	Source	Output OFF	Output ON
Compressor Motor Control Relay	Relay	Compressor OFF	Compressor ON
Hot Gas Bypass	Solenoid	No Bypass	Bypass
Liquid Injection	Solenoid	No Injection	Injection
Oil Pump	Contactora	Pump OFF	Pump ON
Oil Sump Heater	Relay	Heater OFF	Heater ON
Vane Pulse	Solenoid	Hold	Move Vanes
Vane Load/Unload	Solenoid	Unload	Load

Unit Startup and Maintenance

NOTE: Installation and maintenance are to be performed only by qualified personnel who are familiar with local codes and regulations, and experienced with this type of equipment.

 **DANGER**

LOCKOUT/TAGOUT all forms of hazardous energy and power sources prior to starting, pressurizing, de-pressuring, or powering down the chiller. Failure to follow this warning exactly can result in serious injury or death. Be sure to read and understand the installation, operation, and service instructions within this manual.

 **CAUTION**

Dyes used for refrigerant leak detection are not tested or recommended for use in Daikin Applied chillers. Use of these products may damage and/or degrade the performance of the equipment and will void the manufacturer warranty.

 **DANGER**

Prevent lint, paper fibers, dust, metallic chips, or other foreign material from getting into the inverter or accumulating on VFD cooling inlets, the heat sinks, circuit boards, control panels, or other electrical devices. Failure to do so may affect operation of the VFD, void warranty, result in a fire, unit damage, property damage, severe personal injury, or death. Frequently inspect area around inverter, heatsink, and other electrical devices to ensure they are free of foreign material.

Pre-Startup

Inspect the chiller to ensure no components became loose or damaged during shipping or installation including leak test and wiring check. Complete the pre-start checklist at the front of this manual and return to Daikin Applied prior to startup date.

NOTICE

Daikin Applied service personnel or factory authorized service agency must perform initial startup in order to activate warranty. Return the “Centrifugal Compressor Equipment Startup/Warranty Registration Form” within 10 working days to Daikin Applied as instructed on the form to obtain full warranty benefits.

Routine Maintenance

 **CAUTION**

Improper servicing of the lubrication system, including the addition of excessive or incorrect oil, substitute quality oil filter, or any mishandling can damage the equipment. Only authorized and trained service personnel should attempt this service. For qualified assistance, contact your local Daikin Applied service location.

Lubrication

After the system is placed into operation, no other additional oil is required except in the event that repair work becomes necessary to the oil pump, or unless a large amount of oil is lost from the system due to a leak.

If oil must be added with the system under pressure, use a hand pump with its discharge line connected to the backseat port of the valve in the lubricant drain from the compressor to the sump. The POE oils used with R-134a and R-513A are hygroscopic and care must be exercised to avoid exposure to moisture (air).

The condition of compressor oil can be an indication of the general condition of the refrigerant circuit and compressor wear. An annual oil check by a qualified laboratory is essential for maintaining a high level of maintenance. It is useful to have an oil analysis at initial startup to provide a benchmark from which to compare future tests. The local service office can recommend suitable facilities for performing these tests. “Oil Analysis” on page 67 discusses this important maintenance item in greater detail and Table 33 on page 69 gives the upper limits for metals and moisture in the polyolester lubricants required by Daikin Applied chillers.

POE type oil is used for compressor lubrication. This type of oil is extremely hygroscopic, which means it will quickly absorb moisture if exposed to air and may form acids that can be harmful to the chiller. Avoid prolonged exposure of POE oil to the atmosphere to prevent issues. For more details on acceptable oil types, contact your Daikin Applied service representative.

 **WARNING**

This unit contains POE lubricants that must be handled carefully and the proper protective equipment (gloves, eye protection, etc.) must be used when handling POE lubricant. Failure to do so can result in personal injury. POE must not come into contact with any surface or material that might be harmed by POE, including certain polymers (e.g. PVC/CPVC and polycarbonate piping).

 **WARNING**

Polyolester Oil, commonly known as POE oil is a synthetic oil used in many refrigeration systems, and is present in this Daikin Applied product. POE oil, if ever in contact with PVC/CPVC, will coat the inside wall of PVC/CPVC pipe causing environmental stress fractures. Although there is no PVC/CPVC piping in this product, please keep this in mind when selecting piping materials for your application, as system failure and property damage could result. Refer to the pipe manufacturer’s recommendations to determine suitable applications of the pipe.

It is important that only the manufacturer’s recommended oils be used. Acceptable POE oil types are:

- CPI/Lubrizol Emkarate RL32H
- Exxon/Mobil EAL Arctic 46
- Hatcol 3692
- Everest 46

Changing Oil Filters

Daikin Applied chillers are at positive pressure at all times and do not leak contaminated moist air into the refrigerant circuit, thereby eliminating the need for annual oil changes. An annual laboratory oil analysis is recommended to check overall compressor condition.

The oil filter can be changed by simply isolating the filter cavities. Close the oil discharge line service valve at the oil pump (at the filter on CE126). Remove the filter cover; some foaming can occur but the check valve should limit leakage from other compressor cavities. Remove the filter, replace with new element, and replace filter cover using a new gasket. Reopen the valve in the pump discharge line and purge air from the oil filter cavity.

When machine is operated again, the oil level must be checked to determine if oil needs to be added to maintain the proper operating level.

Refrigerant Cycle

Maintenance of the refrigerant cycle includes maintaining a log of the operating conditions, and checking that the unit has the proper oil and refrigerant charge.

At every inspection, the oil, suction, and discharge pressures should be noted and recorded, as well as condenser and chiller water temperatures.

The suction line temperature at the compressor should be taken at least once a month. Subtracting the saturated temperature equivalent of the suction pressure from this will give the suction superheat. Extreme changes in subcooling and/or superheat over a period of time will indicate losses of refrigerant or possible deterioration or malfunction of the expansion valves. Proper superheat setting is 0 to 1 degree F (0.5 degree C) at full load. Such a small temperature difference can be difficult to measure accurately. Another method is to measure the compressor discharge superheat, the difference between the actual discharge temperature and the saturated discharge temperature. The discharge superheat should be between 14 and 16 degrees F (8 to 9 degrees C) at full load. The liquid injection must be deactivated (by closing the valve in the feed line) when taking the discharge temperature. The superheat will increase linearly to 55 degrees F (30 degrees C) at 10% load. The MicroTech II interface panel can display all superheat and subcooling temperatures.

Electrical System

Maintenance of the electrical system involves the general requirement of keeping contacts clean and connections tight and checking on specific items as follows:

1. The compressor current draw should be checked and compared to nameplate RLA value. Normally, the actual current will be lower, since the nameplate rating represents full load operation. Also check all pump and fan motor amperages, and compare with nameplate ratings.
2. Inspection must verify that the oil heaters are operative. The heaters are insert-cartridge type and

can be checked by ammeter reading. They should be energized whenever power is available to the control circuit, when the oil temperature sensor calls for heat, and when the compressor is inoperative. When the compressor runs, the heaters are de-energized. The Digital Output screen and second View screen on the operator interface panel both indicate when the heaters are energized.

3. At least once a quarter, all equipment protection controls except compressor overloads should be made to operate and their operating points checked. A control can shift its operating point as it ages, and this must be detected so the controls can be adjusted or replaced. Pump interlocks and flow switches should be checked to be sure they interrupt the control circuit when tripped.
4. The contactors in the motor starter should be inspected and cleaned quarterly. Tighten all terminal connections.
5. The compressor motor resistance to ground should be checked and logged semi-annually. This log will track insulation deterioration. A reading of 50 megohms or less indicates a possible insulation defect or moisture and must be further checked.
6. The centrifugal compressor must rotate in the direction indicated by the arrow on the rear motor cover plate, near the rotation sight glass. If the operator has any reason to suspect that the power system connections have been altered (phases reversed), the compressor must be jogged clockwise to check rotation. For assistance, call the local Daikin Applied service location.

CAUTION

Never Megger a motor while in a vacuum. Severe motor damage can result.

Cleaning and Preserving

A common cause of service calls and equipment malfunction is dirt. This can be prevented with normal maintenance. The frequency of service will vary with each installation.

1. Remove and clean strainers in chilled water system, oil cooler line and condenser water system at every inspection.
2. Inspect the condenser tubes annually for fouling and clean if required. The dished water heads (aka end-bells, water boxes) should be removed with care due to their weight. One method follows:
 - After draining water, remove all but four head bolts at roughly 10 and 2 o'clock and 4 and 8 o'clock.
 - Loosen the remaining four bolts to enable the head to be separated from the tube sheet sufficiently for a clevis pin or hook to be inserted into an open bolt hole at the top of the head.
 - Attach a hoist to the pin or hook, lift the head to remove weight from the remaining bolts, remove the

bolts and carefully remove the head.

- Do not try to install an eyebolt with machine threads into the head vent fitting, which has pipe threads.
- Reverse this procedure to mount the head, using a new gasket.

Annual Shutdown

Seasonal Servicing

Prior to shutdown periods and before starting up again, the following service procedures must be completed.

Where the chiller can be subject to freezing temperatures, the condenser and chiller must be drained of all water. Dry air blown through the condenser will aid in forcing all water out. Removal of condenser heads is also recommended. The condenser and evaporator are not self-draining and tubes must be blown out. Water permitted to remain in the piping and vessels can rupture these parts if subjected to freezing temperature.

Forced circulation of antifreeze through the water circuits is one method of avoiding freeze up.

1. Take measures to prevent the shutoff valve in the water supply line from being accidentally turned on.
2. If a cooling tower is used, and if the water pump will be exposed to freezing temperatures, be sure to remove the pump drain plug and leave it out so any water that can accumulate will drain away.
3. Open the compressor disconnect switch, and remove the fuses. If the transformer is used for control voltage, the disconnect must remain on to provide power to the oil heater. Set the manual UNIT ON/OFF switch in the Unit Control Panel to the OFF position.
4. Check for corrosion and clean and paint rusted surfaces.
5. Clean and flush water tower for all units operating on a water tower. Make sure tower blowdown or bleed-off is operating. Set up and use a good maintenance program to prevent "liming up" of both tower and condenser. It should be recognized that atmospheric air contains many contaminants that increase the need for proper water treatment. The use of untreated water can result in corrosion, erosion, sliming, scaling or algae formation. It is recommended that the service of a reliable water treatment company be used. Daikin Applied assumes no responsibility for the results of untreated or improperly treated water.
6. Remove condenser heads at least once a year to inspect the condenser tubes and clean if required.

Annual Startup

A dangerous condition can exist if power is applied to a faulty compressor motor starter that has been burned out. This condition can exist without the knowledge of the person starting the equipment.

This is a good time to check all the motor winding resistance

to ground. Semi-annual checking and recording of this resistance will provide a record of any deterioration of the winding insulation. All new units have well over 100 megohms resistance between any motor terminal and ground.

Whenever great discrepancies in readings occur, or uniform readings of less than 50 megohms are obtained, the motor cover must be removed for inspection of the winding prior to starting the unit. Uniform readings of less than 5 megohms indicate motor failure is imminent and the motor should be replaced or repaired. Repair before failure occurs can save a great deal of time and labor spent in the cleanup of a system after a motor burnout.

1. The control circuit must be energized at all times, except during service. If the control circuit has been off and oil is cool, energize oil heaters and allow 24 hours for heater to remove refrigerant from the oil before starting.
2. Check and tighten all electrical connections.
3. Replace the drain plug in the cooling tower pump if it was removed at shutdown time the previous season.
4. Install fuses in main disconnect switch (if removed).
5. Reconnect water lines and turn on supply water. Flush condenser and check for leaks.

Repair of System

Pressure Relief Valve Replacement

Current condenser designs use two relief valves separated by a three-way shutoff valve (one set). This three-way valve allows either relief valve to be shut off, but at no time can both be shut off. In the event one of the relief valves are leaking in the two valve set, these procedures must be followed:

- If the valve closest to the valve stem is leaking, back seat the three-way valve all the way, closing the port to the leaking pressure relief valve. Remove and replace the faulty relief valve. The three-way shutoff valve must remain either fully back seated or fully forward to normal operation. If the relief valve farthest from the valve stem is leaking, front seat the three-way valve and replace the relief valve as stated above.
- The refrigerant must be pumped down into the condenser before the evaporator relief valve can be removed.

Pumping Down

If it becomes necessary to pump the system down, extreme care must be used to avoid damage to the evaporator from freezing. Always make sure that full water flow is maintained through the chiller and condenser while pumping down. To pump the system down, close all liquid line valves. With all liquid line valves closed and water flowing, start the compressor. Set the MicroTech II control to the manual load. The vanes must be open while pumping down to avoid a surge or other damaging condition. Pump the unit down until the MicroTech II controller cuts out at approximately 20 psig. It is possible that the unit might experience a mild surge condition prior to cutout. If this should occur, immediately shut off the compressor. Use a portable condensing unit to complete the

pump down, condense the refrigerant, and pump it into the condenser or pumpout vessel using approved procedures.

A pressure regulating valve must always be used on the drum being used to build the system pressure. Also, do not exceed the test pressure given above. When the test pressure is reached disconnect the gas cylinder.

Pressure Testing

No pressure testing is necessary unless some damage was incurred during shipment. Damage can be determined upon a visual inspection of the exterior piping, checking that no breakage occurred or fittings loosened. Service gauges should show a positive pressure. If no pressure is evident on the gauges, a leak may have occurred, discharging the entire refrigerant charge. In this case, the unit must be leak tested to determine the location of the leak.

Leak Testing

In the case of loss of the entire refrigerant charge, the unit must be checked for leaks prior to charging the complete system. This can be done by charging enough refrigerant into the system to build the pressure up to approximately 10 psig (69 kPa) and adding sufficient dry nitrogen to bring the pressure up to a maximum of 125 psig (860 kPa). Leak test with an electronic leak detector. Halide leak detectors do not function with R-134a or R-513A. Water flow through the vessels must be maintained anytime refrigerant is added or removed from the system.

If any leaks are found in welded or brazed joints, or it is necessary to replace a gasket, relieve the test pressure in the system before proceeding. Brazing is required for copper joints.

After making any necessary repair, the system must be evacuated as described in the following section.

Evacuation

After it has been determined that there are no refrigerant leaks, the system must be evacuated using a vacuum pump with a capacity that will reduce the vacuum to at least 1000 microns of mercury.

A mercury manometer, or an electronic or other type of micron gauge, must be connected at the farthest point from the vacuum pump. For readings below 1000 microns, an electronic or other micron gauge must be used.

The triple evacuation method is recommended and is particularly helpful if the vacuum pump is unable to obtain the desired 1 millimeter of vacuum. The system is first evacuated to approximately 29 inches of mercury. Dry nitrogen is then added to the system to bring the pressure up to zero pounds.

Then the system is once again evacuated to approximately 29 inches of mercury. This is repeated three times. The first pulldown will remove about 90% of the noncondensables, the second about 90% of that remaining from the first pulldown and, after the third, only 1/10-1% noncondensables will remain.

Charging the System

WSC water chillers are leak tested at the factory and shipped with the correct charge of refrigerant as indicated on the unit nameplate. In the event the refrigerant charge was lost due to shipping damage, the system should be charged as follows after first repairing the leaks and evacuating the system.

1. Connect the refrigerant drum to the gauge port on the liquid line shutoff valve and purge the charging line between the refrigerant cylinder and the valve. Then open the valve to the mid-position.
2. Turn on both the cooling tower water pump and chilled water pump and allow water to circulate through the condenser and the chiller. (It will be necessary to manually close the condenser pump starter.)
3. If the system is under a vacuum, stand the refrigerant drum with the connection up, and open the drum and break the vacuum with refrigerant gas to a saturated pressure above freezing.
4. With a system gas pressure higher than the equivalent of a freezing temperature, invert the charging cylinder and elevate the drum above the condenser. With the drum in this position, valves open, water pumps operating, liquid refrigerant will flow into the condenser. Approximately 75% of the total requirement estimated for the unit can be charged in this manner.
5. After 75% of the required charge has entered the condenser, reconnect the refrigerant drum and charging line to the service valve on the bottom of the evaporator. Again purge the connecting line, stand the drum with the connection up, and place the service valve in the open position.

NOTE: At this point, the charging procedure should be interrupted and pre-start checks made before attempting to complete refrigerant charge. The compressor must not be started at this time. (Preliminary check must first be completed.)

NOTE: It is of utmost importance that all local, national, and international regulations concerning the handling and emission of refrigerants are observed.

Oil Analysis

Interpreting Oil Analysis Data

Oil wear metals analysis has long been recognized as a useful tool for indicating the internal condition of rotating machinery and continues to be a preferred method for Daikin Applied centrifugal chillers. Daikin Applied service or a number of laboratories specializing in oil testing can do the test. To accurately estimate the internal condition it is essential to properly interpret the oil wear test results.

Numerous test results from various testing laboratories have recommended action that has prompted unnecessary concern by customers. Polyolester oils are excellent solvents and can readily dissolve trace elements and contaminants. Most of these elements and contaminants eventually end up in the oil. Also, the polyolester oils used in R-134a and R-513A chillers

are more hygroscopic than mineral oils and can contain much more water in solution. For this reason, it is imperative that extra care be used when handling polyolester oils to minimize their exposure to ambient air. Extra care must also be used when sampling to ensure that sample containers are clean, moisture-free leak proof and non-permeable.

Daikin Applied has done extensive testing in conjunction with refrigerant and lubricating oil manufacturers and has established guidelines to determine action levels and the type of action required.

In general Daikin Applied does not recommend changing lubricating oils and filters on a periodic basis. The need to change lubricating oil and filters should be based on a careful consideration of oil analysis, vibration analysis and knowledge of the operating history of the equipment. A single oil sample is not sufficient to estimate the condition of the chiller. Oil analysis is only useful if employed to establish wear trends over time. Changing lubricating oil and filter prior to when its needed will reduce the effectiveness of oil analysis as a tool in determining machinery condition.

The following metallic elements or contaminants and their possible sources will typically be identified in an oil wear analysis:

Aluminum

Typical sources of aluminum are bearings, impellers, seals or casting material. An increase in aluminum content in the lubricating oil may be an indication of bearing, impeller or other wear. A corresponding increase in other wear metals may also accompany an increase in aluminum content.

Copper

The source of copper can be the evaporator or condenser tubes, copper tubing used in the lubrication and motor cooling systems or residual copper from the manufacturing process. The presence of copper may be accompanied by a high TAN (total acid number) and high moisture content. High copper contents may also result from residual mineral oil previously used in machines. Some mineral oils contained wear inhibitors which react with copper and result in high copper content in lubricating oil.

Iron

Iron in the lubricating oil can originate from compressor castings, oil pump components, shells, tube sheets, tube supports, shaft material and rolling element bearings. High iron content may also result from residual mineral oil previously used in machines. Some mineral oils contain wear inhibitors which react with iron and can result in a high iron content in the lubricating oil.

Tin

The source of tin may be from bearings.

Zinc

There is no zinc used in the bearings on Daikin Applied chillers.

The source, if any, may be from additives in some mineral oils.

Lead

The source of lead in Daikin Applied centrifugal chillers is the thread sealant compounds used during chiller assembly. The presence of lead in the lubricating oil in Daikin Applied chillers does not indicate bearing wear.

Silicon

Silicon can originate from residual particles of silicon left from the manufacturing process, filter drier material, dirt or anti-foam additives from residual mineral oil which may be present in machines.

Moisture

Moisture in the form of dissolved water can be present in lubricating oil to varying degrees. Some polyolester oils may contain up to 50 parts per million (ppm) of water from new unopened containers. Other sources of water may be the refrigerant (new refrigerant may contain up to 10 ppm water), leaking evaporator condenser tubes or oil coolers, or moisture introduced by the addition of either contaminated oil or refrigerant or improperly handled oil.

Liquid R-134a has the ability to retain up to 1400 ppm of water in solution at 100 degrees F. With 225 ppm of water dissolved in liquid R-134a, free water would not be released until the liquid temperature reached -22 degrees F. Liquid R-134a can hold approximately 470 ppm at 15 degrees F (an evaporator temperature which could be encountered in ice applications). Since free water is what causes acid production, moisture levels should not be of a concern until they approach the free water release point.

A better indicator of a condition which should be of concern is the TAN (Total Acid Number). A TAN below 0.09 requires no immediate action. TANs above 0.09 require certain actions. In the absence of a high TAN reading and a regular loss of refrigerant oil (which may indicate a heat transfer surface leak) a high moisture content in an oil wear analysis is probably due to handling or contamination of the oil sample. It should be noted that air (and moisture) can penetrate plastic containers. Metal or glass containers with gasket in the top will slow moisture entry.

In conclusion, a single element of an oil analysis should not be used as the basis to estimate the overall internal condition of a Daikin Applied chiller. The characteristics of the lubricants and refrigerants, and knowledge of the interaction of wear materials in the chiller must be considered when interpreting a wear metal analysis. Periodic oil analysis performed by a reputable laboratory and used in conjunction with compressor vibration analysis and operating log review can be helpful tools in estimating the internal condition of a Daikin Applied chiller.

Normal Sample Intervals

Daikin Applied recommends that an oil analysis be performed annually. Professional judgment must be exercised under unusual circumstances, for example, it might be desirable to sample the lubricating oil shortly after a unit has been placed

back into operation after it has been opened for service, as recommended from previous sample results or after a failure. The presence of residual materials from a failure should be taken into consideration in subsequent analysis. While the unit is in operation, the sample should be taken from a stream of refrigerant oil, not in a low spot / quiet area.

Table 33: Upper Limit For Wear Metals And Moisture In Polyolester Lubricants

Element	Upper Limit (PPM)	Action
Aluminum	50	1
Copper	100	1
Iron	100	1
Moisture	150	2&3
Silica	50	1
Total Acid Number (TAN)	0.19	3

Corresponding Action:

1. Re-sample after 500 hours of unit operation. If content increases less than 10%, change oil and filter and re-sample at normal interval. If content increases between 11% and 24%, change oil and oil filter and re-sample after an additional 500 hours of operation. If content increases 25% or more, inspect compressor.
2. Re-sample after 500 hours of unit operation. If content increases less than 10%, change filter drier and re-sample at normal interval. If content increases between 11% and 24%, change filter-drier and re-sample after an additional 500 hours of operation. If content increases 25% or more, monitor for water leak. Since POE lubricants are hygroscopic, many times the high moisture level is due to inadequate handling and packaging. The TAN reading **MUST BE USED** in conjunction with moisture readings.
3. For TAN between .10 and .19, re-sample after 1000 hours of unit operation. If TAN increases above 19, change oil, oil filter and filter drier and re-sample at normal interval.

Flow Switch Installation and Calibration

A thermal dispersion flow switch uses heat to determine flow and therefore must be calibrated during system startup. A thermal dispersion flow switch can be an acceptable replacement for paddle type flow switches and differential pressure switches but care must be taken regarding wiring.

The thermal dispersion flow switch supplied by Daikin Applied, shown in Figure 1, comes as a 2 part unit consisting of a flow switch and an adapter labeled E40242 by the supplier.

Figure 75: Thermal Dispersion Flow Switch and Adapter

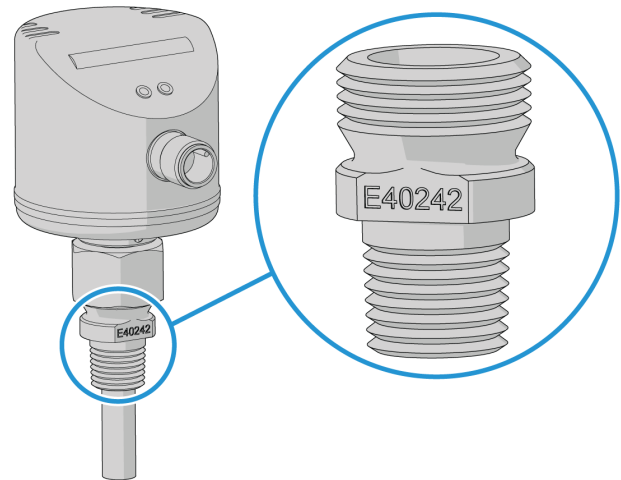

NOTICE

Flow switch **MUST** be calibrated before chiller operation. Failure to properly calibrate the switch may result in severe chiller damage and/or void warranty.

Mounting

Figure 76 highlights the position of the electrical connector and indentation 'mark' on flow switch.

It is required that the flow switch be mounted such that the electrical connection and indentation 'mark' are oriented as recommended in Figure 77. It is important that the flow switch be mounted so that the probe is sufficiently inserted into the fluid stream. It may not be mounted directly on top or directly on the bottom of a horizontal pipe.

Figure 76: Flow Switch Details

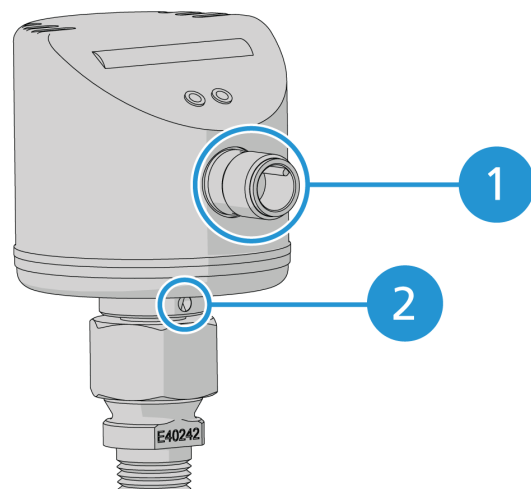



If the flow sensor is to be mounted away from the unit, the sensor should be mounted on the wall of the inlet pipe of evaporator and condenser, or in a run of straight pipe that allows 5 to 10 pipe diameters prior to the sensor and 3 to 5 pipe diameters of straight pipe after the sensor. Flow switch

is placed in inlet pipe to reflect flow entering the barrel. If installation on the outlet pipe is necessary, contact Chiller Technical Response at TechResponse@DaikinApplied.com to review the jobsite details.

NOTE: DO NOT alter or relocate factory installed flow switch. If issues exist, contact Chiller Technical Response at TechResponse@DaikinApplied.com.

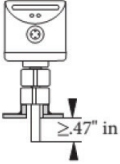
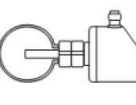
Figure 77: Remote Mounting Guidelines for Flow Switch

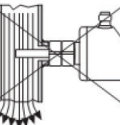
<p>General</p> <ul style="list-style-type: none"> The sensor tip is to be completely surrounded by the medium. Insertion depth of the sensor: minimum .47" in. 		
<p>Recommended</p> <ul style="list-style-type: none"> For horizontal pipes: mounting from the side. For vertical pipes: mounting in the rising pipe. 		
<p>To avoid</p> <ul style="list-style-type: none"> The sensor tip must not be in contact with the pipe wall. Do not mount in downpipes that are open at the bottom! 		

If needed, the adapter is threaded into the pipe using pipe sealant appropriate for the application. The flow sensor is mounted onto the adapter using silicone grease. Carefully apply lubricant to the inside threads and o-ring so temperature probe does not become coated with lubricant. Torque the adapter/sensor connection to 18.5 ft/lbs.

Wiring

Refer to wiring diagram in the unit control panel.

Either AC or DC is used to power the flow switch. The unit controller's digital input is a DC signal which is supplied through the switch output of the flow switch for flow indication. It is required that the AC and DC commons of power be separated. Contact Chiller Technical Response for alternate wiring scenarios.

Flow Switch Setup

The flow switch comes from the factory set at a default velocity of 20 cm/s. This value is typically well below the minimum water flow specified for the unit's evaporator and condenser so field adjustment is required for adequate low flow protection. Figure 79 shows the calculated gallons per minute (gpm) for Schedule 40 steel pipe for various fluid velocities from 20 cm/s to 300 cm/s. The flow switch has an overall range of adjustment from 3 cm/s to 300 cm/s.

1. Adjust flow through the evaporator to the minimum desired operating gpm. Maintain this flow throughout the setup procedure.
2. Once steady state minimum desired operating flow is obtained, perform the 'Teach' function on the flow switch. The 'Teach' function is initiated by holding down

the minus '-' button on the face of the flow switch for 15 seconds. During this 15 second period, LEDs '0' and '9' will be lit green. Once the 'Teach' function is completed, the outer LEDs will flash green.

Figure 78: Automatic Teach of Setpoint

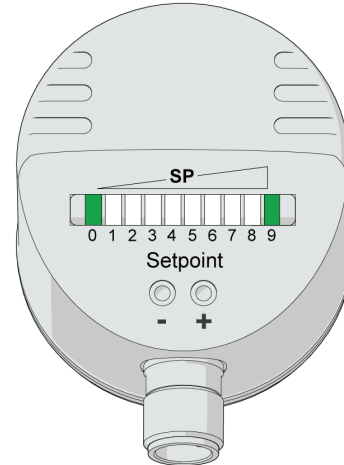

3. After the 'Teach' function is completed and the outer LEDs flashed, the flow switch will indicate a new set point based upon the current flow which should still be at the steady state minimum desired operating flow. Figure 79 shows a typical display for this condition. All LEDs to the left of the SP LED are lit green. The SP LED is lit RED (or may toggle amber) which indicates that the flow switch is OPEN. Typically, an increase in fluid flow is between 15% to 30% above the 'Teach' function flow is required for the SP LED to turn AMBER and the flow switch to CLOSE indicating acceptable flow.

Figure 79: Teach Adjustment Complete

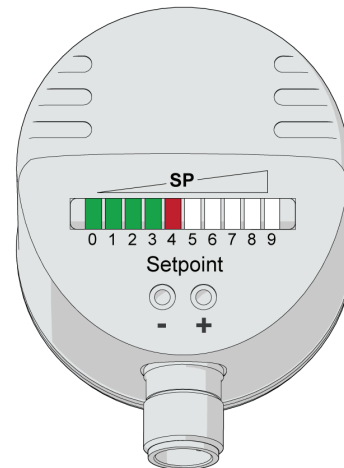
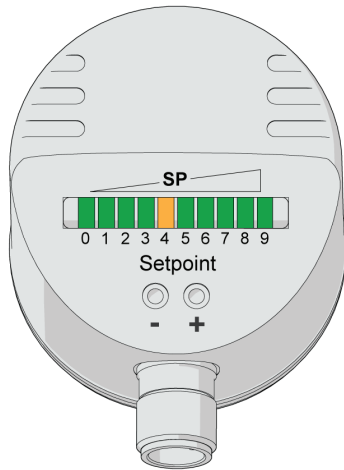

Table 34: Flow Volume Calculation

Pipe Size (inch)	Inside Pipe Diameter (inch)	US GPM at the velocities indicated below									GPM adjustment per '+' or '-' key input
		Default									
		20 cm/sec	30 cm/sec	50 cm/sec	75 cm/sec	100 cm/sec	150 cm/sec	200 cm/sec	250 cm/sec	300 cm/sec	
2	2.06	6.86	10.3	17.2	25.7	34.3	51.5	68.6	85.8	102.9	1.72
2.5	2.46	9.79	14.7	24.5	36.7	49.0	73.4	97.9	122.4	146.9	2.42
3	3.07	15.1	22.7	37.8	56.7	75.6	113.4	151.2	189.0	226.8	3.78
3.5	3.55	20.2	30.3	50.6	75.8	101.1	151.7	202.2	252.8	303.3	5.06
4	4.03	26.0	39.1	65.1	97.7	130.2	195.3	260.4	325.5	390.5	6.51
5	5.05	40.9	61.4	102.3	153.5	204.6	306.9	409.2	511.5	613.7	10.2
6	6.07	59.1	88.6	147.7	221.6	295.5	443.2	590.9	738.7	886.3	14.8
8	7.98	102.3	153.5	255.8	383.7	511.6	767.5	1023.3	1279.1	1534.7	25.6
10	10.02	161.3	241.9	403.2	604.8	806.5	1209.7	1612.9	2016.2	2419.1	39.0
12	11.94	229.0	343.4	572.4	858.6	1144.7	1717.1	2289.5	2861.9	3433.8	57.2
14	13.13	276.8	415.2	692.0	1037.9	1383.9	2075.9	2767.8	3459.8	4151.3	69.2
16	15.00	361.5	542.2	903.6	1355.5	1807.3	2710.9	3614.6	4518.2	5421.2	90.4
18	16.88	457.5	686.3	1143.8	1715.7	2287.6	3431.4	4575.2	5719.0	6862.1	114.4
20	18.81	572.4	853.0	1421.6	2132.4	2843.2	4264.8	5686.4	7108.0	8528.6	142.2

Figure 80: Upper Range of Minimum Flow



In Step 3, the 'Teach' function re-adjusted the flow switch set point (SP) while flow was at the minimum desired operating flow. The chiller will not operate at this flow because the flow switch is OPEN after performing the 'Teach' function. The benefit of the 'Teach' function is to quickly set the set point within the desired operating range. Additional 'manual' adjustment of set point is required in order to allow for chiller operation at this minimum flow. The '+' and '-' buttons on the face of the flow switch allow for the manual adjustment of the SP. Pressing the '+' button reduces the flow set point while pressing the '-' button increases the flow set point. Each button press, '+' or '-', changes the flow set point by 2.5 cm/s.

- Press the '+' button until LED '9' begins to flash, as shown in Figure 80. Opening of flow switch should now occur at approximately 80% to 90% of minimum flow.
- Once the SP is set, it is recommended that the sensor be locked to avoid inadvertent readjustment. This can be performed by pressing both the '+' and '-' buttons

simultaneously for 10 seconds. The indication goes out momentarily indicating the unit is locked. To unlock, the same procedure is performed to toggle to unlocked.

NOTE: The LED window display on flow switch represents a velocity range of 50 cm/s. The window centers on the set point (SP). For example, if the SP was set to 200 cm/s, then the LED labeled '0' would represent a velocity of 180 cm/s when lit and the LED labeled 9 would represent a velocity of 230 cm/s when lit.

Each LED represents 5 cm/s, or two presses of the '+' or '-' buttons.

When power is initially applied to the flow switch, all green LEDs light and go out step by step. During this time, the output is closed. The unit is in the operating mode.

When making manual adjustments to the set point (SP), if no button is pressed for 2 seconds, the unit returns to the operating mode with the newly set value.

Flow below display range: The SP LED will be lit red and the leftmost LED will be flashing green. For example, if the SP was set to 200 cm/s, the flashing labeled '0' would indicate that the flow was below 180 cm/s. This would be shown if no flow through chiller or lowered than desired flow.

Figure 81: Display for Flow Below Range

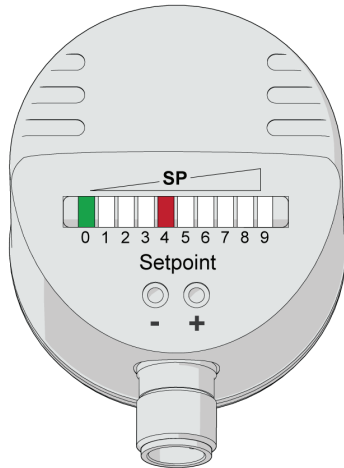

Flow above display range: The SP LED will be lit amber, all LEDs to the left and right of the SP LED will be green with the rightmost LED flashing green. For example, if the SP was set to 200 cm/s, the flashing LED labeled '9' would indicate that the flow was above 230 cm/s. This may be a normal display depending on range by which flow varies through chiller.

Figure 82: Display for Flow Above Range

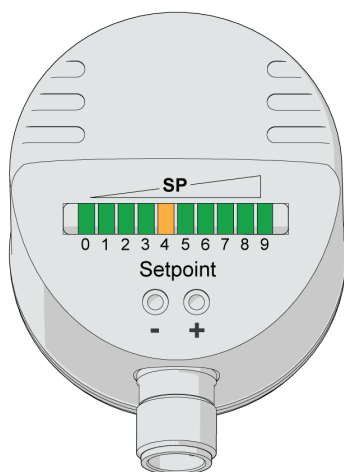

Service Programs

It is important that an air conditioning system receive adequate maintenance if the full equipment life and full system benefits are to be realized.

Maintenance should be an ongoing program from the time the system is initially started. A full inspection should be made after 3 to 4 weeks of normal operation on a new installation, and on a regular basis thereafter.

Daikin Applied offers a variety of maintenance services through the local Daikin Applied service office, its worldwide service organization, and can tailor these services to suit the needs of the building owner. Most popular among these services is the Daikin Applied Comprehensive Maintenance Contract.

For further information concerning the many services available, contact your local Daikin Applied service office.

Maintenance Schedule Notes

1. Some compressors use power factory correction capacitors and all have a surge capacitor (excepting units with solid state starters). The surge capacitor can be installed out of sight in the compressor motor terminal box. In all cases, capacitors must be disconnected from the circuit to obtain a useful Megger reading. Failure to do so will produce a low reading. In handling electrical components, only fully qualified technicians must attempt service
2. Approach temperature (the difference between the leaving water temperature and the saturated refrigerant temperature) of either the condenser or evaporator is a good indication of tube fouling, particularly in the condenser, where constant flow usually prevails. Daikin Applied's high efficiency heat exchangers have very low design approach temperatures, in the order of one to one and one half degrees F.

The chiller unit controller can display the water and the saturated refrigerant temperatures. Simple subtraction will give the approach. It is recommended that benchmark readings (including condenser pressure drop to confirm future flow rates) be taken during startup and then periodically afterward. An approach increase of two-degrees or more would indicate that excessive tube fouling could be present. Higher than normal discharge pressure and motor current are also good indicators
3. Evaporators in closed fluid circuits with treated water or anti-freeze are not normally subject to fouling, however it is prudent to check the approach periodically. Some evaporators may have a mixture of 3/4-inch and 1-inch tubes.
4. Performed when contracted for, not part of standard initial warranty service.
5. Oil filter change and compressor teardown and inspection should be done based on the results of the annual oil test performed by a company specializing in this type of test. Consult Daikin Applied service for recommendations.

Table 35: Maintenance Schedule

Maintenance Check List Item	Daily	Weekly	Monthly	Quarterly	Annually	5-Yr	As Req'd
Unit							
Operational Log	O						
Analyze Operational Log		O					
Refrigerant Leak Test Chiller		O					
Test Relief Valves or Replace						X	
Compressor							
Vibration Test Compressor					X		
Motor							
Meg. Windings (Note 1)					X		
Ampere Balance (within 10% at RLA)				O			
Terminal Check - measure infrared temp					X		
Motor Cooling Filter Drier Pressure Drop					X		
Lubrication System							
Clean Oil Cooler Strainer (water)					X		
Oil Cooler Solenoid Operation				O			
Oil Appearance (clear color, quantity)		O					
Oil Filter Pressure Drop			O				
Oil Analysis (Note 5)					X		
Oil change if indicated by oil analysis							X
Controls							
Operating Controls							
Calibrate Temperature Transducers					X		
Calibrate Pressure Transducers					X		
Check Vane Control Setting & Operation					X		
Verify Motor Load Limit Control					X		
Verify Load Balance Operation					X		
Check Oil Pump Contactor					X		
Protective Controls - Test Operation of:							
- Alarm Relay				X			
- Pump Interlocks				X			
- Guardistor and Surgeguard Operation				X			
- High and Low Pressure Cutouts				X			
- Oil Pump Pressure Differential Cutout				X			
- Oil Pump Time Delay				X			
Condenser							
Evaluation of Temp Approach (NOTE 2)			O				
Test Water Quality				V			
Clean Condenser Tubes (NOTE 2)					X		X
Eddy current Test - Tube Wall Thickness						V	
Seasonal Protection							X
Evaporator							
Evaluation of Temp Approach (NOTE 2)			O				
Test Water Quality					V		
Clean Evaporator Tubes (NOTE 3)							X
Eddy current Test - Tube Wall thickness						V	X
Seasonal Protection							X
Expansion Valves							
Operational Evaluation (Superheat Control)				X			
Starter							
Examine Contactors (hardware & operation)				X			
Verify Overload Setting and Trip				X			
Test Electrical Connections (Infrared temp measurement)				X			
Optional Controls							
Hot Gas Bypass (verify operation)				X			



**DAIKIN APPLIED AMERICAS INC.
LIMITED PRODUCT WARRANTY
(North America)**

Daikin Applied Americas Inc. dba Daikin Applied (“Company”) warrants to contractor, purchaser and any owner of the product (collectively “Owner”) that Company, at its option, will repair or replace defective parts in the event any product manufactured by Company, including products sold under the brand name Daikin and used in the United States or Canada, proves defective in material or workmanship within twelve (12) months from initial startup or eighteen (18) months from the date shipped by Company, whichever occurs first. Authorized replaced parts are warranted for the duration of the original warranty. All shipments of such parts will be made FOB factory, freight prepaid and allowed. Company reserves the right to select carrier and method of shipment.

In addition, labor to repair or replace warranty parts is provided during Company normal working hours on products with rotary screw compressors and centrifugal compressors. Warranty labor is not provided for any other products.

Company’s liability to Owner under this warranty shall not exceed the lesser of the cost of correcting defects in the products sold or the original purchase price of the products.

PRODUCT STARTUP ON CENTRIFUGAL AND SCREW COMPRESSOR PRODUCTS IS MANDATORY and must be performed by a Daikin Applied or a Company authorized service representative.

It is Owner’s responsibility to complete and return the Registration and Startup Forms accompanying the product to Company within ten (10) days of original startup. If this is not done, the ship date and the startup date will be deemed the same for warranty period determination, and this warranty shall expire twelve (12) months from that date.

EXCEPTIONS

1. If free warranty labor is available as set forth above, such free labor does not include diagnostic visits, inspections, travel time and related expenses, or unusual access time or costs required by product location.
2. Refrigerants, fluids, oils and expendable items such as filters are not covered by this warranty.
3. This warranty shall not apply to products or parts which (a) have been opened, disassembled, repaired, or altered by anyone other than Company or its authorized service representative; or (b) have been subjected to misuse, negligence, accidents, damage, or abnormal use or service; or (c) have been operated, installed, or startup has been provided in a manner contrary to Company’s printed instructions, or (d) were manufactured or furnished by others and which are not an integral part of a product manufactured by Company; (e) have been exposed to contaminants, or corrosive agents, chemicals, or minerals, from the water supply source, or (f) have not been fully paid for by Owner.

ASSISTANCE

To obtain assistance or information regarding this warranty, please contact your local sales representative or a Daikin Applied office.

SOLE REMEDY

THIS WARRANTY CONSTITUTES THE OWNER’S SOLE REMEDY. IT IS GIVEN IN LIEU OF ALL OTHER WARRANTIES. THERE IS NO IMPLIED WARRANTY OF MERCHANTABILITY OR FITNESS FOR A PARTICULAR PURPOSE. IN NO EVENT AND UNDER NO CIRCUMSTANCE SHALL COMPANY BE LIABLE FOR INCIDENTAL, INDIRECT, SPECIAL, CONTINGENT OR CONSEQUENTIAL DAMAGES, WHETHER THE THEORY BE BREACH OF THIS OR ANY OTHER WARRANTY, NEGLIGENCE OR STRICT LIABILITY IN TORT.

No person (including any agent, sales representative, dealer or distributor) has the authority to expand the Company’s obligation beyond the terms of this express warranty or to state that the performance of the product is other than that published by Company.

For additional consideration, Company will provide an extended warranty(ies) on certain products or components thereof. The terms of the extended warranty(ies) are shown on a separate extended warranty statement.



Daikin Applied Training and Development

Now that you have made an investment in modern, efficient Daikin Applied equipment, its care should be a high priority. For training information on all Daikin Applied HVAC products, please visit us at www.DaikinApplied.com and click on Training, or call 540-248-9646 and ask for the Training Department.

Warranty

All Daikin Applied equipment is sold pursuant to its standard terms and conditions of sale, including Limited Product Warranty. Consult your local Daikin Applied representative for warranty details. To find your local Daikin Applied representative, go to www.DaikinApplied.com.

Aftermarket Services

To find your local parts office, visit www.DaikinApplied.com or call 800-37PARTS (800-377-2787). To find your local service office, visit www.DaikinApplied.com or call 800-432-1342.

This document contains the most current product information as of this printing. For the most up-to-date product information, please go to www.DaikinApplied.com.

Products manufactured in an ISO Certified Facility.