

MICROTECH[®] CONTROLLER

FOR PRECISELINE[®] LIGHT AIR HANDLERS



Safety Information	3	Unit Maintenance	47
Hazard Identification	3	Service Menus	48
Safety Considerations	3	Modbus Settings	49
Introduction	4	Alarm Lists	52
Unit Description	4	Main Control Board (POL546)	54
Menu Description Tables Glossary	5	Expansion Module A I/O (POL965)	54
Nomenclature	6	Save / Restore Settings	54
Portable Interface	7	Advanced Menus	55
Keypad and Display	9	Unit Configuration	55
Field Control Wiring	11	About This AHU	71
MicroTech Unit Controller Field Installed Sensors ..	12	Appendix	72
Manual Control	13	Example Wiring Diagrams	72
Manual Control Mode	13		
VRV D-Kit Test Mode	15		
Quick Menu	16		
Commission Unit	20		
Unit Set-Up	20		
Enable the Unit	20		
Occupancy Mode	20		
Dirty Filter Notification	21		
Remote Integrated Thermostat Operation	21		
View Status	32		
Scheduling	32		
Unit State	32		
Heating/Cooling Changeover	33		
Supply Air Fan	34		
Exhaust Fan	34		
Cooling	35		
Heating	36		
Dehumidification	37		
Dehumidification Operation	38		
Changeover Valve	38		
Outside Air Damper	39		
Economizer Control	39		

©2024 Daikin Applied, Minneapolis, MN. All rights reserved throughout the world. This document contains the most current product information as of this printing. Daikin Applied Americas Inc. has the right to change the information, design, and construction of the product represented within the document without prior notice. For the most up-to-date product information, please go to www.DaikinApplied.com.

™@ MicroTech, SiteLine, PreciseLine, and Daikin Applied are trademarks or registered trademarks of Daikin Applied Americas Inc. The following are trademarks or registered trademarks of their respective companies: BACnet from American Society of Heating, Refrigerating and Air-Conditioning Engineers, Inc.; Echelon, LonWorks, LonMark, and LonTalk from Echelon Corporation; Modbus from Schneider Electric; and Windows from Microsoft Corporation.

Safety Information

Hazard Identification

DANGER

Danger indicates a hazardous situation, which will result in death or serious injury if not avoided.

WARNING

Warning indicates a potentially hazardous situations, which can result in property damage, personal injury, or death if not avoided.

CAUTION

Caution indicates a potentially hazardous situations, which can result in minor injury or equipment damage if not avoided.

NOTICE

Notice indicates practices not related to physical injury.

NOTE: Indicates important details or clarifying statements for information presented in Figures or Tables.

Safety Considerations

This manual provides installation, operation, and maintenance information for Daikin Applied MicroTech Unit Controller with PreciseLine Light Air Handler units.

NOTICE

Installation and maintenance are to be performed only by licensed, if required by local codes and regulations, or qualified personnel who are familiar with local codes and regulations and are experienced with this type of equipment.

DANGER

LOCKOUT/TAGOUT all power sources prior to service, pressurizing, depressurizing, or powering down the unit. Failure to follow this warning exactly can result in serious injury or death. Disconnect electrical power before servicing the equipment. More than one disconnect may be required to deenergize the unit. Be sure to read and understand the installation, operation, and service instructions within this manual.

WARNING

Electric shock hazard. Improper handling of this equipment can cause personal injury or equipment damage. This equipment must be properly grounded. Connections to and service of the MicroTech control panel must be performed only by personnel that are knowledgeable in the operation of the equipment being controlled.

WARNING

Polyolester Oil, commonly known as POE oil is a synthetic oil used in many refrigeration systems, and may be present in this Daikin Applied product. POE oil, if ever in contact with PVC/CPVC, will coat the inside wall of PVC/CPVC pipe causing environmental stress fractures. Although there is no PVC/CPVC piping in this product, please keep this in mind when selecting piping materials for your application, as system failure and property damage could result. Refer to the pipe manufacturer's recommendations to determine suitable applications of the pipe.

CAUTION

Static sensitive components. A static discharge while handling electronic circuit boards can cause damage to the components. Discharge any static electrical charge by touching the bare metal inside the control panel before performing any service work. Never unplug any cables, circuit board terminal blocks, or power plugs while power is applied to the panel.

Introduction

This manual provides operating information about the MicroTech unit controller as pertains to PreciseLine light air handler models. For installation and/or maintenance procedures, see Daikin Applied IM 1267.

WARNING

Only qualified personnel should install, operate and service the equipment and that improper adjustment of settings and operation by an unqualified person could result in property damage, injury, or death.

Unit Description

A typical unit will range between three sizing categories, as shown in the following figures. These figures are for general information only. See the project's certified submittals for actual specific dimensions and locations.

Figure 1: Typical Size 006-020 Units (Horizontal)



Figure 2: Typical Size 006-020 Units (Vertical)



Figure 3: Typical Size 030-050 Units (Horizontal)



Figure 4: Typical Size 030-050 Units (Vertical)



Figure 5: Typical Size 060-100 Units



Menu Description Tables Glossary

Menu Name	Location
About This AHU	page 69
Active Alarms	page 50
Advanced Timers	page 55
Air Filter Set-Up	page 29
Alarm Log	page 50
BACnet MSTP Set-Up	page 45
CO2 Set-Up	page 62
ChngOvr Vlv Set-Up	page 58
Cooling	page 42
Cooling Set-Up	page 24
Cooling Set-Up (Advanced)	page 60
CW Clg Set-Up	page 59
Date/Time	page 42
Date/Time/Schedule	page 41
Dehumidification Set-Up	page 25
Dehumidification Set-Up (Advanced)	page 63
Dehumidification	page 43
Econo Set-Up Menu	page 27
Econo Set-Up (Advanced)	page 61
Economizer	page 43
EF Set-Up	page 23
EF Set-Up (Advanced)	page 57
El Htg Set-Up	page 60
Heating	page 43
Heating Set-Up	page 61
HW Htg Set-Up	page 59
I/O Module Status	page 51
I/O Status	page 51
I/O Readings	page 68
IAQ Status	page 44
Manual Control	page 14
Modbus Settings	page 47
Network Input Status	page 46
OA Damper Set-Up	page 27
Occupancy	page 40
Operating Hours	page 46
Preheat Set-Up	page 57
Quick Menu	page 16
SAF Control	page 42
SAF Set-Up	page 22
SAF Set-Up (Advanced)	page 56
Save/Restore Settings	page 52
Supheat Set-Up	page 57
Temperatures	page 43
Timer Settings	page 21
Unit Configuration	page 53
Unit Set-Up	page 21
Unit Status/Settings	page 39
View Status	page 39

Nomenclature

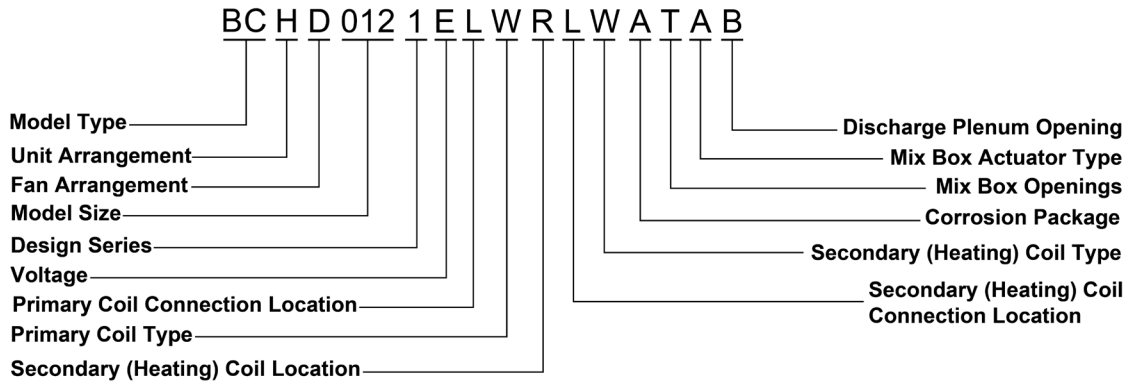

Category	Code	Description
Model Type	BC	PreciseLine Air Handler
Unit Arrangement	H	Horizontal
	V	Vertical
	A	AVD / Compact Vertical (Sizes 006-020)
Fan Arrangement	D	Draw Thru
	E	Draw Thru Plenum Fan, End Discharge
	U	Draw Thru Plenum Fan, Up Discharge
Model Size	006	Nominal 600 CFM
	008	Nominal 800 CFM
	010	Nominal 1,000 CFM
	012	Nominal 1,200 CFM
	016	Nominal 1,600 CFM
	018	Nominal 1,800 CFM
	020	Nominal 2,000 CFM
	030	Nominal 3,000 CFM
	040	Nominal 4,000 CFM
	050	Nominal 5,000 CFM
	060	Nominal 6,000 CFM
	080	Nominal 8,000 CFM
100	Nominal 10,000 CFM	
Design Series	1	1st Vintage
Voltage	A	115/60/1
	E	208/60/1
	G	460/60/1
	K	230/60/1
	P	277/60/1
	D	208/60/3
	L	230/60/3
	T	460/60/3
	W	575/60/3
Primary Coil Connection Location	L	Left Hand (Air back of the head)
	R	Right Hand (Air back of the head)
	C	Center

Category	Code	Description
Primary Coil Type	W	Water / Glycol
	D	DX / 410A
	V	VRV
Secondary (Heating) Coil Location	P	Preheat
	R	Reheat
	Y	None
Secondary (Heating) Coil Connection Location	L	Left Hand (Air back of the head)
	R	Right Hand (Air back of the head)
	Y	None
	C	Center
Secondary (Heating) Coil Type	W	Hot Water / Glycol
	Y	None
	S	Steam
Corrosion Package	A	(Coil Casing) Stainless / (Fin Coating) None / (Drip Pan Corrosion Pkg.) Stainless
	Y	(Coil Casing) Galvanized / (Fin Coating) None / (Drip Pan Corrosion Pkg.) Galvanized
Mix Box Openings	T	Top + Rear
	B	Bottom + Rear
	Y	None
Mix Box Actuator Type	T	ON/OFF
	A	0-10V M
	M	Manual
	Y	None
Discharge Plenum Opening	B	Bottom
	T	Top
	E	End
	Y	None - No Discharge Plenum
	R	Right Hand (Air back of the heat)
	L	Left Hand (Air back of the head)
	F	Field Cut-Out (Has a Plenum)

NOTE: Not all code options shown.

Portable Interface

⚠ WARNING

Electric shock hazard. Can cause personal injury, death, or property damage.

This equipment must be properly grounded. Connections and service to the MicroTech unit controller must be performed only by personnel knowledgeable in the operation of the equipment being controlled.

1. Remove plastic cover (Figure 6) to access the RJ45 connection.
2. Mount the portable interface. The portable interface has magnets for mounting to metallic surfaces.

Figure 6: Removing the Cover

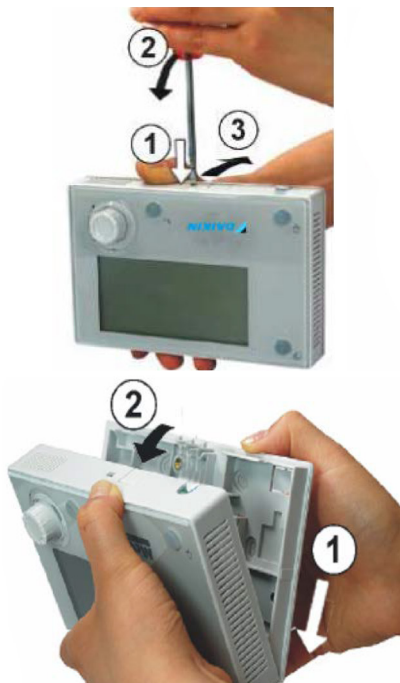

Direct Connection

The portable interface can be wired directly to a single MicroTech unit controller over a standard RJ45 (Ethernet) connection.

1. Locate the external RJ45 plug shown in Figure 7

Interface Details for RJ45 Connector:

- Bus connection - RJ45 Interface
- Max length of shielded cable: 164 ft (50 m)
- Max length of unshielded cable: 9.8 ft (3 m)
- Cable type: standard Ethernet cable

Figure 7: Connection Port (Size 030 Shown)

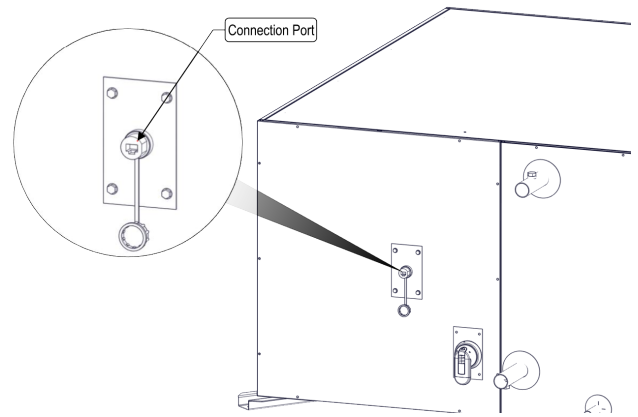

Using the Portable Interface

Hardware Features

The portable interface keypad/display consists of an 8-line by 30 character display, a “push and roll” navigation wheel, and three buttons: Alarm, Home (Menu), and Back (Figure 8).

- Turn the navigation wheel clockwise (right) or counterclockwise (left) to navigate between lines on a screen and also to increase and decrease changeable values when editing. Press down on the wheel to use it as an Enter button.
- Press the Back button to display the previous page.
- Press the Home button to return to the main screen from the current page.
- Press the Alarm button to view the Alarm Lists menu.

Keypad/Display Features

The first line on each page includes the page title and the line number to which the cursor is currently “pointing.” The line numbers are X/Y to indicate line number X of a total of Y lines for that page. The left most position of the title line includes an “up” arrow to indicate there are pages “above” the currently displayed items, a “down” arrow to indicate there are pages “below” the currently displayed items or an “up/down” arrow to indicate there are pages “above and below” the currently displayed page. Each line on a page can contain status-only information or include changeable data fields. When a line contains status-only information and the cursor is on that line, all but the value field of that line is highlighted - meaning the text is white with a black box around it. When the line contains a changeable value and the cursor is at that line, the entire line is highlighted.

Each line on a page may also be defined as a “jump” line, meaning pushing the navigation wheel will cause a “jump” to a new page. An arrow is displayed to the far right of the line to indicate it is a “jump” line and the entire line is highlighted when the cursor is on that line.

NOTICE

Only menus and items that are applicable to the specific unit configuration are displayed.

Figure 8: Portable Interface Main Features

Keypad/Display Functions

The keypad/display information is organized into a series of menus or menu groups designed to allow navigation through unit operating parameters and editing access to customize unit performance.

Passwords control access to service technician level and field engineering level parameters.

Advanced menus include the most advanced items such as “unit configuration” and service related parameters. These generally do not require changes unless there is a fundamental change to (or a problem with) unit operation.

NOTICE

Only menus and items that are applicable to the specific unit configuration are displayed.

Passwords

When the keypad/display is first accessed, the Home Key is pressed, the Back Key is pressed multiple times, or if the keypad/display has been idle for the Password Timeout timer (default 10 minutes), the display will show a “main” page where the user can enter a password or continue without entering a password.

Various menu functions are accessible or inaccessible, depending on the access level of the user, and the password they enter, if any. There are four access levels, including no password, Level 2, Level 4, and Level 6, with Level 2 having the highest level of access. Without entering a password, the user has read-only access to current basic menu items including Quick Menu, Alarm Lists, and About This AHU menus. Alarms can be acknowledged at this level. Entering the Level 6 password (5321) allows access to basic menu items plus the View Status menu group. Entering the Level 4 password (2526) allows similar access as Level 6 with the addition of the Commission Unit and Service Menu groups. Entering the Level 2 password (6363) allows similar access as Level 4 with the addition of the Manual Control and Unit Maintenance menus, plus Advanced Menus accessible through the Service Menu.

The password field initially has a value **** where each * represents an adjustable numeric field. These values can be changed by entering the Edit Mode.

Entering an invalid password has the same effect as continuing without entering a password.

Once a valid password has been entered, the selected access is maintained until either the password timer expires or a different password is entered. The default value for this password timer is 10 minutes and may be changed in the Advanced Timers menu (Advanced Menus).

Navigation Mode

In the Navigation Mode, values which can be edited are indicated by the entire line being highlighted (black box with white text). Values which are “read only”, displayed for information only, will have only the parameter name highlighted.

When the navigation wheel is turned clockwise, the cursor moves to the next line (down) on the page. When the wheel is turned counter-clockwise the cursor moves to the previous line (up) on the page. The faster the wheel is turned the faster the cursor moves.

When the Back Button is pressed the display reverts back to the previously displayed page. If the Back button is repeatedly pressed the display continues to revert one page back along the current navigation path until the “main menu” is reached.

When the Menu (Home) Button is pressed the display reverts to the “main page.”

When the Alarm Button is depressed, the Alarm Lists menu is displayed. Repeated pressing of the Alarm Button toggles between active alarms and the alarm history.

Edit Mode

The Editing Mode is entered by pressing the navigation wheel while the cursor is pointing to a line containing an editable field. Once in the edit mode pressing the wheel again causes the editable field to be highlighted. Turning the navigation wheel clockwise or counter-clockwise will either increase or decrease the value in the selected field, respectively.

The faster the wheel is turned the faster the value is incremented. Pressing the wheel will save the new value and return the display to the navigation mode. Pressing the back button will exit the editing mode without saving the change.

Figure 10: Advanced Menu Keypad Navigation

To Access the Advanced Menu Scroll to this location: Main Menu \ Service Menu; Scroll to the bottom of the Service menu and set the Ena Adv Menu = Yes. Return to the Main Menu. Now the Advanced Menu will be visible for 30 min.

Advanced Menus

- Advanced Timers
- SAF Set-Up
- EF Set-Up
- Cooling Set-Up
- CW Valve Set-Up
- Heating Set-Up
- Preheat Set-Up
- Supheat Set-Up
- HW Valve Set-Up
- EH Htg Set-Up
- ChgOvr Viv Set-Up
- Econo Set-Up
- Dehum Set-Up
- CO2 Set-Up
- Unit Configuration
- IO Readings

1 Zone VAV Control

1ZnVAV Period=10s
1ZnVAV Gain= 1.0
1ZnVAV PAT= 100s
1ZnVAVMaxChg=10%

EF Set-Up

EF Dampnr Setpt= 20%
EF Const Speed Setpt= 75%

Cooling Set-Up

Lead Compressor=RunTime
Compressor Diff= 2.00°F
CigPerd= 10s
Cig Gain= 1.0
CigPAT= 100s
Cig Max Chg= 10.0°F
Compressor Avail= _____
Comp Off Timer= XXXs
Comp On Timer= XXXs
Cooling Stage Timer= XXXs
Desired Cooling= XXX%
Desired Cooling Stg= X
Current Cooling Stg= X
Comp Turn On= _____
Comp Turn Off= _____
Cig PI Target= XXX°F
Cig PI Input= XXX°F
Cig PI Output= XXX%

CW Valve Set-Up

Cig Perd= 20s
Cig Gain= 1.0
Cig PAT= 40s
Cig Max Chg= 15.0%
Htg Period= 60s
Htg Gain= 1.5
Htg PAT= 90s
Htg Max Chg= 10.0%
CO Valve Direction= Direct
CO Valve Signal= OnOff24VAC
EWT Diff= 5.0°F
EWT= XXX°F
Htg PI Target= XXX°F
Htg PI Input= XXX°F
Htg PI Output= XXX%
HW Htg Avail= _____
Cig PI Target= XXX°F
Cig PI Input= XXX°F
Cig PI Output= XXX%

Heating Set-Up

Comp Htg Turn On= _____
Comp Htg Turn Off= _____
All Htg Maxed= _____

Preheat Set-Up

Preheat Source= OAT
EUT Sp= 20.0°F
PH En Diff Sp= 10.0°F
PH Tgt Sp= 16.0°F
PH OAT Diff Sp= 2.0°F
PH OAT Tgt Sp= 23.0°F
Preheat Temp In= XXX°F

Supheat Set-Up

Supheat Source= None
Sup Heat Needed= NotNeeded
Sup Heat En Time= 5m
Sup Heat En Diff= 2.0°F
SupHtg Wait Done= FALSE
Sup Heat Dy Time= 15m

HW Valve Set-Up

Htg Period= 60s
Htg Gain= 1.5
Htg PAT= 90s
Htg Max Chg= 10.0%
HW Viv Direction= Direct
HW Viv Signal= OnOff24VAC
HW Heating Avail= _____
Htg PI Target= XXX°F
Htg PI Input= XXX°F
Htg PI Output= XXX%

EH Htg Set-Up

Htg Period= 10s
Htg Gain= 1.0
Htg PAT= 100s
Htg Max Chg= 10%
Htg PI Target= XXX°F
Htg PI Input= XXX°F
Htg PI Output= XXX%
Desired Htg Stage= X
Current Htg Stage= X
Ei Heat Cmd= NONE

ChgOvr Viv Set-Up

Cig Perd= 20s
Cig Gain= 1.0
Cig PAT= 40s
Cig Max Chg= 15.0%
Htg Period= 60s
Htg Gain= 1.5
Htg PAT= 90s
Htg Max Chg= 10.0%
CO Valve Direction= Direct
CO Valve Signal= OnOff24VAC
EWT Diff= 5.0°F
EWT= XXX°F
Htg PI Target= XXX°F
Htg PI Input= XXX°F
Htg PI Output= XXX%
HW Htg Avail= _____
Cig PI Target= XXX°F
Cig PI Input= XXX°F
Cig PI Output= XXX%

Econo Set-Up

Strategy= None
OAD Out Scaling= Linear
OAD Min= 20%
OAD Max= 100%
RAD Out Scaling= Linear
RAD Min= 20%
RAD Max= 100%
Econo OAT Setpt= 70.0°F
Oat Enth Setpt= 28.0BTU/lb
Temp Diff Setpt= 2.0°F
Enth Diff Setpt= 2.0BTU/lb
OAT Lockout Ena= Disabled
OAT Lockout Setpt= 36.0°F
Econo Stg Time= 5min
Outdoor Enthalpy= XXBTU/lb
Indoor Enthalpy= XXBTU/lb
OAT High Status= _____
OAT Lockout Status= _____
OAT Status= _____
Econo Avail= _____
DCV OA Signal= XXX%
Efi Econo Strategy= _____

Dehum Set-Up

Dehum Htg Disable= Inactive
Dehum Strategy= None
Dehum Type= Dewpt
Dehum Required= _____
Dehum CW Viv Cmd= XXX%
Dehum Cmp Cig Cmd= XXX%
Dehum HW Viv Cmd= _____
Dehum EH Cmd= _____
Dehum Available= _____
Dehum DAT Sp= 70.0°F
Dehum Htg DAT Sp= 80.0°F
Dehum Wait Done= FALSE

CO2 Set-Up

DCV Enable= Disabled
Min OA CO2 Sp= 500ppm
Max OA CO2 Sp= 2000ppm
DCV OA Signal= XXX%
DCV Status= _____

Alarm Set-Up

High DAT Lim Sp= 170.0°F
Low DAT Lim Sp= 40.0°F
DAT Alm Dly Sp= 35s
Low AirTemp Alm Dly= 6m

IO Reading

MCB UNIVERSAL

MCB X1= XXX
MCB X2= XXX
MCB X3= XXX
MCB X4= XXX
MCB X5= XXX
MCB X6= XXX
MCB X7= XXX
MCB X8= XXX
MCB X9= XXX
MCB X10= XXX
MCB X11= XXX

EMA UNIVERSAL

EMA X1= XXX
EMA X2= XXX
EMA X3= XXX
EMA X4= XXX
EMA X5= XXX
EMA X6= XXX
EMA X7= XXX
EMA X8= XXX

MCB DI

MCB DI1= _____
MCB DI2= _____
MCB DI3= _____
MCB DI4= _____
MCB DI5= _____
MCB DI6= _____
EMA DI2= _____
MCB DI6= _____
MCB DO1= _____
MCB DO2= _____
MCB DO3= _____
MCB DO4= _____
MCB DO5= _____
MCB DO6= _____
MCB DO7= _____
MCB DO8= _____
MCB DO9= _____
MCB DO10= _____

EMA DO

EMA DO1= _____
EMA DO2= _____
EMA DO3= _____
EMA DO4= _____
EMA DO5= _____
EMA DO6= _____

Unit Configuration

Apply Changes= No
SAF Control= Const(0)
HeatCool Valve= None(0)
EWT= NotInst(0)
2/4 Pipe= 2-Pipe(0)
Valve Signal= OnOff24VAC(2)
Cool Valve Dir= Direct(0)
Heat Valve Dir= Direct(0)
Chng Valve Dir= Direct(0)
Ei Heat Stages= None(0)
Ei Heat Type= PRIMARY(0)
Compressor Stages= None(0)
D-Kit Quantity= On(0)
D-Kit Temp Src= Space(0)
Ctrl Humidity Src= Space(0)
Preheat Temp. In= OAT(0)
LCT Sensor Type= SingleP(0)
DCV Enable= Disable(0)
CO2 Sensor= NotInst(0)
EconoMize= None(0)
Outdoor Damper= NotInst(0)
Space Hum Sensor= NotInst(0)
OA Hum Sensor= NotInst(0)
Return Air Damper= NotInst(0)
Exhaust Fan= Disabled(0)
Exh Fan Output= NotInst(0)
Dehumidification= None(0)
Lvg Coil Sensor= NotInst(0)
Econo FDD= Disabled(0)
Damper End Sw= NotInst(0)
Filter Notification= None(0)
RAT Sensor= NotInst(0)
Air Flow Proving= NotInst(0)
Remote Sensor= Installed(1)
Config Index= _____
Config Fault= _____
Apply Changes= No

This navigation map represents all possible menus and menu items. Not all menus and items shown here will appear on the HMI display depending upon the specific unit configuration. Those that do not appear are not applicable to this unit.

Field Control Wiring

 DANGER
LOCKOUT/TAGOUT all power sources prior to wiring or servicing the unit. Electrical shock hazard may cause injury, death, or property damage. Connect only low voltage NEC Class II circuits to terminal blocks TB2, TB4, and TB12. Reinstall and secure all protective front panels when the wiring installation is complete.

PreciseLine units are available with several control schemes which may require low voltage field wiring. Use the Unit Specific Electrical Schematics to determine which control connections will be required for installation. Check unit specific electrical documentation in the door of the control panel. [Table 1](#) shows the possible field connections that can be made.

Table 1: Potential Field Connections and Locations (Sizes 006-050)

	Label	Description	Signal
TB12	T1	Freezestat	24VAC Contact Closure
	T2	Condensate Overflow	Discrete Contact Closure
	T3	Space Humidity Sensor	0-10 VDC Input
	T4	Compressor 2	24VAC Output
	T5	Discharge Air Temperature	Thermistor Input
	T6	Airflow Switch	24VAC Contact Closure
	T7	Entering Water Temp / Leaving Coil Temp	Thermistor Input
	T8	Duct Static Pressure	0-10 VDC Input
	T9	Duct Static Pressure Power	24 VDC Supply
	T10	Emergency Stop	Discrete Contact Closure
	T11	Remote Space Sensor (CE-)	Remote Space Sensor Communications (CE-)
	T12	Remote Space Sensor (CE+)	Remote Space Sensor Communications (CE+)
TB4	T1	Supply Fan Signal	0-10 VDC Output
	T2	Compressor 1 or Valve 1	24VAC Output / 0-10 VDC Output
	T3	Electric Heat or Valve 2	24VAC Output / 0-10 VDC Output
	T4	Outside Air Damper	0-10 VDC Output
TB2	24+	Supply Voltage	24VAC Output Supply
	Common	Supply Voltage Common	Ground

Table 2: Potential Field Connections and Locations (Sizes 060-100)

	Label	Description	Signal
TB2	24+	Supply Voltage	24VAC Output Supply
	N24	Supply Voltage Common	Ground
	236	Sensor Common	Sensor Common
	+24V	Sensor Power MCB	24VDC Supply MCB
	+24V-A	Sensor Power EXP-A	24VDC Supply EXP-A
	202	Condensate Overflow Switch	Discrete Contact Closure
	208	Outdoor Air Humidity	0-10VDC Input
	208E	Space Humidity Sensor	0-10VDC Input
	208G	Return Air Humidity Sensor	0-10VDC Input
	210	Remote Space Sensor (CE-)	Remote Space Sensor Communications (CE-)
	212	Remote Space Sensor (CE+)	Remote Space Sensor Communications (CE+)
	213	Space CO2	0-10VDC Input
	220	Freeze Stat	24VAC Contact Closure
	222	SCR Electric Heat/Modulating Hot Water Valve Output	0-10VDC Output
	222C	Electric Heat Stage 1	24VAC Output
	223	Electric Heat Stage 2	24VAC Output
	224	Electric Heat Stage 3	24VAC Output
	225	Electric Heat Stage 4	24VAC Output
	228C	Hot Water Valve On Off	24VAC Output
	232A	Dirty Filter Switch	Discrete Contact Closure
	247	Leving Coil Temp	Thermistor Input
	249	Compressor 1/Chilled Water Valve On Off	24VAC Output
	251	Compressor 2	24VAC Output
	254	Compressor 3	24VAC Output
	256	Compressor 4	24VAC Output
	262	Expansion Board Common	Ground
	267	Supply Fan Signal	0-10VDC Output
	275	Exhaust Fan Signal	0-10VDC Output
	277	Outdoor Air Damper	0-10VDC Output
	281	Discharge Air Temp	Thermistor Input
	282	Return Air Temp	Thermistor Input
	297	Outdoor Air Temp	Thermistor Input
	299	Emergency Stop	Discrete Contact Closure
2120	Air Flow Switch	24VAC Contact Closure	
2124	Duct Static Pressure	0-10VDC Input	
2130	Damper End Switch	Discrete Contact Closure	
2133	Return Air Damper	0-10VDC Output	
2140	VAV Box Output	24VAC Output	
2150	Modulating Chilled Water Valve	0-10VDC Output	

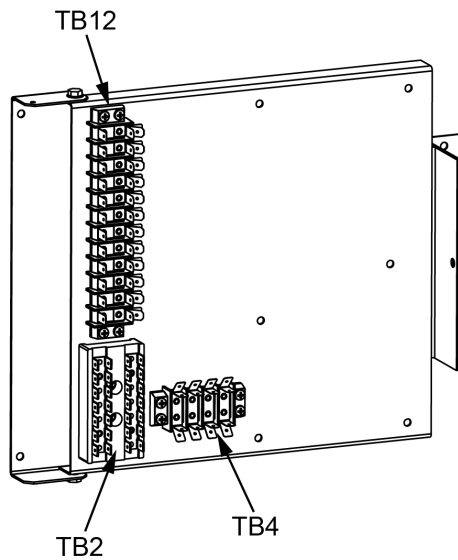
Figure 11: Terminal Block Layout (Sizes 006-050)

MicroTech Unit Controller Field Installed Sensors

The MicroTech unit controller can be connected to a variety of field installed sensors.

- Integrated Thermostat - Daikin Applied PN: 910392744
- Space/Duct Humidity Sensor - Daikin Applied PN: 910392826
- Wall Mounted CO2 Sensor - Daikin Applied PN: 107287012
- Duct Mounted CO2 Sensor - Daikin Applied PN: 910111672
- Duct Static Pressure - Daikin Applied PN: 910236931
- Airflow Status - Daikin Applied PN: 910270652
- OA Temperature - Daikin Applied PN: 910236951
- OA Temp/Humidity Combo - Daikin Applied PN: 910236923
- Leaving Coil Temperature - Daikin Applied PN: 099483400
- Entering Water Temp - Daikin Applied PN: 107201601

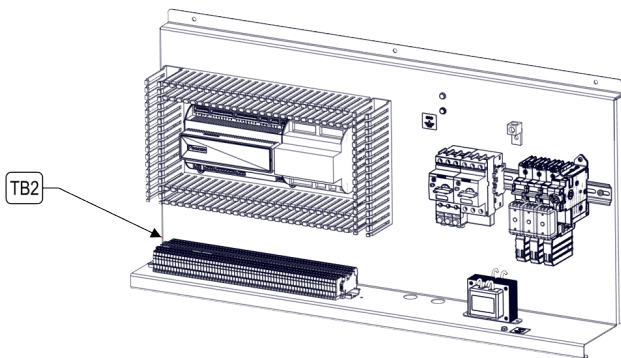
Figure 12: Terminal Block Layout (Sizes 060-100)

PreciseLine units operate with 115V and 24V control circuit power. All field control wiring connections are made at the class II terminal blocks TB2, TB4, and TB12 which is located in the Low Voltage Control Panel, shown in [Figure 11](#) and [Figure 12](#).

NOTE: The installation of all field wiring, must comply with all applicable local codes and ordinances. The warranty may be limited or certain aspects excluded if the field wiring is not in accordance with these standards.

If a single conduit containing 24V and 115V wiring is run above the roofline between units, consider the 24V wiring within as an NEC Class I wiring system.

Manual Control



WARNING

Only qualified personnel should install, operate and service the equipment and that improper adjustment of settings and operation by an unqualified person could result in property damage, injury, or death.

Manual Control mode is used to temporarily command specific components to operate. For Manual Control to operate, a Space Temp Sensor must be connected.

If Manual Control Mode is set to “Enable” and no modifications have been made to any of the override parameters for 30 minutes, the Manual Control Mode will be set to “Normal”.

When the Manual Control Mode changes from “Enable” to “Normal”, all of the Override parameters will return to their default values. The Override parameters will no longer dictate the functionality of the controller outputs, and the unit will return to the Off state based on the Control Mode.

If the Manual Control Mode is set to “Enable” and the Control Mode changes from “Off” to anything else, the Manual Control Mode will change to “Normal” and the unit will momentarily transition to the Off state and then resume normal operation based on the Control Mode.

If Electric Heat is selected in the unit configuration, the Supply Air Fan Capacity Command (SAF Cap Cmd) must be set above 6.0 VCD, and Sup Fan Ena must be enabled before the following parameters can be commanded “On” to prevent the unit from over-heating due to no airflow:

- Heating Valve/SCR Heat
- Heating Stage 1
- Heating Stage 2
- Heating Stage 3
- Heating Stage 4

NOTICE

Manual operation is not intended for extended operation beyond troubleshooting or initial start-up.

Manual Control Mode

The Control Mode must be set to “Off” before entering the Manual Control mode.

Manual Control is designed to temporarily allow the technician to control the unit as desired for Start-up or troubleshooting. There are four Manual Control Modes:

1. Normal

When Manual Control is enabled and Manual Control Mode is set to Normal, all parameters in [Table 3](#) can be set by the technician.

2. Cooling

When Manual Control is disabled and Manual Control Mode is set to Cooling, the unit will attempt to operate to maximum cooling capacity. The unit will adhere to normal operating sequences and alarm responses.

3. Heating

When Manual Control is disabled and Manual Control Mode is set to Heating, the unit will attempt to operate to maximum heating capacity. The unit will adhere to normal operating sequences and alarm responses.

4. Dehumidification

When Manual Control is disabled and Manual Control Mode is set to Dehum, the unit will attempt to operate in dehumidification mode. The unit will adhere to normal operating sequences and alarm responses.

Changing the Manual Control Mode to anything but “Normal” will reset Manual Control to “Normal”.

Manual Control Mode will time out after 30 minutes of inactivity.

When Manual Control Mode is not set to “Normal” the timers will set to the associated fixed value.

When Manual Control Mode is set to “Heating” the unit will attempt to go to full heating capacity, regardless of the control conditions, following the normal unit sequence of operations and adhering to alarms, using the abbreviated timers.

When Manual Control Mode is set to “Cooling” the unit will attempt to go to full cooling capacity, regardless of the actual control conditions, following the normal unit sequence of operations and adhering to alarms, using the abbreviated timers.

When Manual Control Mode is set to “Dehumidification” the unit will attempt to go to dehumidification mode, regardless of the actual control conditions, following the normal unit sequence of operations and adhering to alarms, using the abbreviated timers. If the Manual Control Mode is changed from anything other than “Normal” back to “Normal”, the unit will return to the Off state following normal sequence of operations, using the abbreviated timers.

If Manual Control Mode is not “Normal” and the Control Mode changes from “Off” to anything else, the Manual Control Mode will change to “Normal” and the unit will momentarily transition to the Off state and then resume normal operation based on the Control Mode.

If Manual Control Mode is not “Normal” and no modifications have been made to Manual Control Mode for 30 minutes, the Manual Control Mode will be set to “Normal”.

Manual Control

Table 3: Main Menu \ Manual Control

Menu Display Name	Default	Range	Description
Ctrl Mode=	Off	AUTO	Ctrl Mode is an adjustable item which sets the occupancy mode of the unit. The unit can be Heat Only, Cool Only, Fan Only, Automatic, or Off.
		HEAT	
		COOL	
		FAN_ONLY	
		OFF	
Manual Ctrl=	Normal	NORMAL	Manual Ctrl is an adjustable item that allows the unit to enter manual control.
		ENABLED	
Manual Control Mode=	NORMAL	NORMAL	Manual Control Moder is an adjustable item that allows the unit to manually place the unit in a specified operating mode.
		HEAT	
		COOL	
		DEHUMID	
Manual State=	NORMAL	NORMAL,	Manual State is a status only item that indicates if the unit is in a manual control state.
		HEAT	
		COOL	
		DEHUMID	
SAF Cap Cmd=	0VDC	0-10VDC	SAF Cap Cmd is an adjustable item that manually drive the supply fan to a capacity.
EF Cap Cmd=	0VDC	0-10VDC	EF Cap Cmd is an adjustable item that manually drive the exhaust fan to a capacity.
OADamper Pos=	0VDC	0-10VDC	OADamper Pos an adjustable item that manually drive the outdoor air damper to a position.
RADamper Pos=	0VDC	0-10VDC	RADamper Pos an adjustable item that manually drive the return air damper to a position.
Compressor 1=	Off	Off	Compressor 1 is an adjustable item that manually turns on the Compressor 1 output.
		On	
Compressor 2=	Off	Off	Compressor 2 is an adjustable item that manually turns on the Compressor 2 output.
		On	
Compressor 3=	Off	Off	Compressor 3 is an adjustable item that manually turns on the Compressor 3 output.
		On	
Compressor 4=	Off	Off	Compressor 4 is an adjustable item that manually turns on the Compressor 4 output.
		On	
CW Valve=	0VDC	0-10VDC	CW Valve is an adjustable item that manually sets the Modulating Chilled Water Valve output capacity.

Menu Display Name	Default	Range	Description
CW Valve=	Off	Off	CW Valve is an adjustable item that manually sets the two position Chilled Water Valve output.
		On	
Htg Valve=	0VDC	0-10VDC	Htg Valve is an adjustable item that manually sets the Modulating Hot Water Valve output capacity.
Htg Valve=	Off	Off	Htg Valve is an adjustable item that manually sets the two position Hot Water Valve output.
		On	
SCR Capacity=	0VDC	0-10VDC	SCR Capacity is an adjustable item that manually sets the SCR Electric Heat output capacity.
Htg Stg 1=	Off	Off	Htg Stg 1 is an adjustable item that manually turns on the Electric Heat Stage 1 output.
		On	
Htg Stg 2=	Off	Off	Htg Stg 2 is an adjustable item that manually turns on the Electric Heat Stage 2 output.
		On	
Htg Stg 3=	Off	Off	Htg Stg 3 is an adjustable item that manually turns on the Electric Heat Stage 3 output.
		On	
Htg Stg 4=	Off	Off	Htg Stg 4 is an adjustable item that manually turns on the Electric Heat Stage 4 output.
		On	
Sup Fan Enable	Off	Off	Sup Fan Enable is an adjustable item that manually turns on the Supply Fan Enable output.
		On	
CW/HW CO Valve=	0VDC	0-10VDC	CW/HW CO Valve is an adjustable item that manually sets the Modulating Changeover Valve output capacity.
CW/HW CO Valve=	OFF	OFF,	CW/HW CO Valve is an adjustable item that manually sets the two position Changeover Valve output.
		ON	
VAV Box=	DISABLE	DISABLE,	VAV Box is an adjustable item that manually turns on the VAV Box output.
		ENABLE	

VRV D-Kit Test Mode

When commissioning a unit PreciseLine MicroTech unit controller with D-Kit integrated to a VRV system, it may be necessary to run the VRV outdoor unit in test mode. Before running the outdoor unit in test mode, the MicroTech unit controller “Ctrl Mode” must be set to “Off” and the Supply Fan Minimum Speed must be set to the supply fan nominal operating speed. During the test mode process, the supply fan will be commanded to run at the Supply Fan Minimum Speed when fan operation is requested by the D-Kit controller. Once test mode is complete, the Supply Fan Minimum Speed and Ctrl Mode should be returned to their desired values.

Quick Menu

Items in the Quick Menu contain basic unit operating status and control set point parameters. The items shown in the Quick Menu are Read Only if a valid password has not been entered. The following are brief descriptions of the Quick Menu items. No password is required to view the Quick Menu.

Quick Menu

Table 4: Main Menu \ Quick Menu

Menu Display Name	Default	Range	Description
Unit State=	-	OFF	Unit State is a status only item which indicates the state of unit operation in which the unit is currently operating. The unit can be in any of the operating states shown.
		HEAT	
		COOL	
		ECONO	
		ECONO_COOL	
		DEHUMID	
		FAN_ONLY	
		OVERRIDE	
Ctrl Mode=	Off	AUTO	Ctrl Mode is an adjustable item which sets the control mode of the unit. The unit can be Heat Only, CoolOnly, Fan Only, Automatic, or Off.
		HEAT	
		COOL	
		FAN_ONLY	
		OFF	
Occ Mode=	Auto/Net	OCCUPIED	Occ Mode is an adjustable item which sets the occupancy mode of the unit.
		UNOCCUPIED	
		BYPASS	
		STANDBY	
		AUTO	
Primary Dehumid=	-	DISABLE	Status only item that indicates if dehumidification is active while in the cooling or heating state.
		ENABLE	
CW Valve Pos=	-	0% - 100%	CW Valve Pos is a status only item which indicates the percentage that the modulating chilled water valve is currently open.
CW Valve Pos=	Off	INACTIVE	CW Valve Pos is a status only item which indicates if the two position chilled water valve is currently open.
		ACTIVE	
Comp Stg 1 =	Off	INACTIVE	Comp Stg 1 is a status only item which indicates if the compressor stage 1 output is currently energized.
		ACTIVE	
Comp Stg 2 =	Off	INACTIVE	Comp Stg 2 is a status only item which indicates if the compressor stage 2 output is currently energized.
		ACTIVE	

Menu Display Name	Default	Range	Description
Comp Stg 3 =	Off	INACTIVE	Comp Stg 3 is a status only item which indicates if the compressor stage 3 output is currently energized.
		ACTIVE	
Comp Stg 4 =	Off	INACTIVE	Comp Stg 4 is a status only item which indicates if the compressor stage 4 output is currently energized.
		ACTIVE	
OAD Positon=	-	0% - 100%	OAD Position is a status only item which indicates the percentage that the outdoor air damper is currently open.
HW Valve Pos=	-	0% - 100%	HW Valve Pos is a status only item which indicates the percentage that the modulating hot water valve is currently open.
HW Valve Pos=	-	INACTIVE	HW Valve Pos is a status only item which indicates if the two position hot water valve is currently open.
		ACTIVE	
SCR Output=	-	0% - 100%	SCR Output is a status only item which indicates the percentage that the SCR electric heat output is currently commanded.
Stage 1 Heat=	-	INACTIVE	Stage 1 Heat is a status only item which indicates if the Electric Heat Stage 1 output is currently energized.
		ACTIVE	
Stage 2 Heat=	-	INACTIVE	Stage 2 Heat is a status only item which indicates if the Electric Heat Stage 2 output is currently energized.
		ACTIVE	
Stage 3 Heat=	-	INACTIVE	Stage 3 Heat is a status only item which indicates if the Electric Heat Stage 3 output is currently energized.
		ACTIVE	
Stage 4 Heat=	-	INACTIVE	Stage 4 Heat is a status only item which indicates if the Electric Heat Stage 4 output is currently energized.
		ACTIVE	

Menu Display Name	Default	Range	Description
Control Temp=	-	-40°F - 212°F	Control Temp is a status only item which displays the current value of the "Control Temperature." The "Control Temperature" is defined as the temperature input selected by the Control Temperature Source parameter. For example, if the Control Temperature Source parameter is set to "Return," then the control temperature parameter reads the same value as the Return Air parameter.
EffSpace=	-	-40°F - 212°F	EffSpaceT is a status only item which displays the current temperature reading from an optional space temperature sensor.
Return Temp=	-	-40°F - 212°F	Return Temp is a status only item which displays the current temperature reading from an optional return air temperature sensor.
Active Htg Spt=	-	50°F - 95°F	Active Htg Spt is a status only item which indicates the current active heating setpoint.
Active Clg Spt=	-	50°F - 95°F	Active Clg Spt is a status only item which indicates the current active cooling setpoint.
Occ Clg Spt=	75.0°F	0.0°F - 100.0°F	Occ Clg Spt is an adjustable item which affects the temperature at which the unit will go into the cooling mode of operation when the Control Temperature source is not Outdoor Air Temperature
Occ Htg Spt=	70.0°F	0.0°F - 100.0°F	Occ Htg Spt is an adjustable item which affects the temperature at which the unit will go into the heating mode of operation when the Control Temperature source is not Outdoor Air Temperature
Out Clg Spt=	80.0°F	50°F - 95°F	Out Clg Spt is an adjustable item which affects the temperature at which the unit will go into the cooling mode of operation when the Control Temperature source is Outdoor Air Temperature.

Menu Display Name	Default	Range	Description
Out Htg Spt=	55.0°F	45°F - 70°F	Out Htg Spt is an adjustable item which affects the temperature at which the unit will go into the cooling mode of operation when the Control Temperature source is Outdoor Air Temperature
Sen Clg Spt=	-	-	SenClg Spt is a value set by the optional remote integrate thermostat which affects the temperature at which the unit will go into the cooling mode of operation.
Sen Htg Spt=	-	-	Sen Htg Spt is a value set by the optional remote integrate thermostat which affects the temperature at which the unit will go into the heating mode of operation.
Disch Air=	-	-50.0°F - 250.0°F	Disch Air is a status only item which displays the current temperature reading from the unit's discharge air temperature sensor (DAT).
Effective DAT Spt=	-	45.0°F - 120.0°F	Effective DAT Spt is a status only item which indicates the current active Discharge Air Temperature setpoint.
DAT Clg Spt=	55.0°F	40.0°F - 100.0°F	DAT Clg Spt is a status only item which indicates the temperature that the DAT should be maintained at when it is in the cooling mode of operation. Once a valid password has been entered this item becomes an adjustable item.
DAT Htg Spt=	80.0°F	75.0°F - 120.0°F	DAT Htg Spt is a status only item which indicates the temperature that the DAT should be maintained at when in the heating mode of operation. Once a valid password has been entered this item becomes an adjustable item.
Unocc Clg Spt=	85.0°F	40.0°F - 100.0°F	Unocc Clg Spt is an adjustable item which sets the control temperature above which the unit starts up and provides unoccupied cooling (night setback) during unoccupied periods.

Menu Display Name	Default	Range	Description
Unocc Htg Spt=	60.0°F	40.0°F - 100.0°F	Unocc Htg Spt is an adjustable item which sets the control temperature below which the unit starts up and provides unoccupied heating (night setup) during unoccupied periods.
StdBy Clg Spt=	77.0°F	50°F - 95°F	Stdby Clg Spt is a status only item which indicates the temperature in which the unit will go into the cooling mode of operation in the standby occupancy state. Once a valid password has been entered this item becomes an adjustable item.
StdBy Hlg Spt=	66.0°F	50°F - 95°F	Stdby Hlg Spt is a status only item which indicates the temperature in which the unit will go into the heating mode of operation in the standby occupancy state. Once a valid password has been entered this item becomes an adjustable item.
SAF Capacity=	-	0% - 100%	SAF Capacity is a status only item which indicates the current capacity of the supply air fan.
SAF Duct-Press=	-	0.0 in - 5.0 in	SAF DuctPress is a status only item which displays the current supply duct static pressure reading.
SAF DSP Spt=	1.0 in	0.2 in - 5.0 in	SAF DSP Spt is a status only item which displays the current supply fan duct static pressure setpoint. Once a valid password has been entered this item becomes an adjustable item.
EF Capacity=	-	0% - 100%	EF Capacity is a status only item indicated the current capacity of the return/exhaust fans.
CO2 PPM=	-	0-3000 ppm	
OA Temp=	-	-40.0°F - 212.0°F	OA Temp is a status only item which displays the current temperature reading from the unit mounted Outdoor air temperature sensor.
OA Rel Hum=	-	0% - 100%	OA Rel Hum is a status only item that indicates the current outdoor air relative humidity reading.

Menu Display Name	Default	Range	Description
Indoor Rel Hum =	-	0% - 100%	Indoor Rel Hum is a status only item that indicates the current space relative humidity reading.
Indoor Dew Point =	-	0°F - 100°F	Indoor Dew Point is a status only item that indicates the current calculate space dew-point.
Control Humidity=		0% - 100%	Control Hum is a status only item which indicates the current control relative humidity. The "Control Relative Humidity " is defined as the temperature input selected by the Control Humidity Source parameter.
Control Dewpt=		0°F - 100°F	Control Dewpt is a status only item which indicates the current calculated control dew point. The "Control Relative Dew Point " is defined as the temperature input selected by the Control Humidity Source parameter.
Control Temp Src=	SPACE	SPACE RETURN AVERAGE OUTDOOR	Control Temp Src is an adjustable item that selects the control temperature source from either a space, return air sensor, the average temperature of the space and return, or the outdoor air sensor.
Room Sensor On/Off=	On	OFF ON	Room Sensor On/Off is a value set by the optional remote integrate thermostat which enables or disables unit operation.
RSSysModeStat=	AUTO	AUTO HEAT COOL FAN_ONLY	RSSysModeStat is a value set by the optional remote integrate thermostat which affects the operational mode of the unit. The unit can be Heat Only, Cool Only, Fan Only, or Automatic.
Config Fault Status=	-	-	Config Fault Status is a status only item which displays additional detail about what is causing a Configuration Alarm when the alarm is active

Commission Unit

Unit Set-Up

General unit set-up configurations are used to adjust the MicroTech unit controllers: Units of Measure, Unit Name, and Control Temperature Source.

Unit Name

The unit name will display as "PLAHU".

Control Temperature Source

Control Temperature Source selects what temperature reading is used to change the unit between heating, cooling, and fan only modes. This can be set to the space temperature, return air temperature (if equipped), an average of the space and return air temperature values, or the outdoor air temperature.

Control Humidity Source

Control Humidity Source selects which humidity reading is used to initiate dehumidification. This can be set to the space humidity, outdoor air humidity, or an average of the space and outdoor air humidity. This parameter will also be used to determine what temperature and humidity values will be used to calculate the control dew point.

Enable the Unit

Control Mode

The unit can be set to run in five control modes:

1. **OFF**
The unit is disabled.
2. **HEAT**
Heating functions will operate to maintain the the heating set points. Cooling, economizer, and dehumidification are disabled.
3. **COOL**
Cooling functions will operate to maintain the the cooling set points. Heating is disabled.
4. **AUTO**
All modes of operation are enabled. The unit will automatically switch between heating and cooling modes as necessary.
5. **FAN ONLY**
The circulating fans are allowed to operate. All heating and cooling functions are disabled.

Occupancy Mode

Occupancy mode determines unit functionality based on the current unit setting. The setting can be any of the following:

1. **Occupied**
The unit operates normally, providing heating, cooling, dehumidification, and ventilation as required to maintain the occupied setpoints.
2. **Unoccupied**
The unit operates normally, providing heating, cooling, and dehumidification as required to maintain the unoccupied setpoints. The outdoor air damper remains closed during unoccupied mode, thus ventilation and ecocooling are not functional.
3. **Bypass**
The unit operates normally, providing heating, cooling, dehumidification, and ventilation as required to maintain the occupied setpoints for the duration of the bypass timer.
4. **Standby**
The unit operates normally, providing heating, cooling, dehumidification, and ventilation as required to maintain the standby setpoints.
5. **Auto**
The unit is allowed to automatically shift between occupancy modes in accordance with schedule priorities.

Determining Occupancy Source

The unit's occupancy mode setting can be driven by a number of sources. The priority of the sources is the following:

1. Network Override Command
2. HMI Keypad Input
3. Tenant Override (Thermostat)
4. Network Schedule
5. Internal Schedule

The override setting at the highest priority will be the effective setting for the unit. A "Null" or "Auto" selection will pass control to the next highest priority source.

Table 5: Occupancy Source Table

Network Manual Occupancy	Keypad Manual Occupancy	Tenant Override Input	Network Occupancy Scheduler	Internal Occupancy Scheduler	Effective Occupancy
OCCUPIED	NA	NA	NA	NA	OCCUPIED
UNOCCUPIED	NA	NA	NA	NA	UNOCCUPIED
BYPASS	NA	NA	OCCUPIED	NA	OCCUPIED
			UNOCCUPIED	NA	BYPASS
			STANDBY	NA	BYPASS
			NULL	Occ	OCCUPIED
				Unocc	BYPASS
NULL	NULL	BYPASS			
STANDBY	NA	NA	NA	NA	STANDBY
NULL	OCCUPIED	NA	NA	NA	OCCUPIED
NULL	UNOCCUPIED	NA	NA	NA	UNOCCUPIED
NULL	BYPASS	NA	OCCUPIED	NA	OCCUPIED
			UNOCCUPIED	NA	BYPASS
			STANDBY	NA	BYPASS
			NULL	Occ	OCCUPIED
				Unocc	BYPASS
NULL	NULL	BYPASS			
NULL	STANDBY	NA	NA	NA	STANDBY
NULL	AUTO	INACTIVE	OCCUPIED	NA	OCCUPIED
			UNOCCUPIED	NA	UNOCCUPIED
			STANDBY	NA	STANDBY
			NULL	Occ	OCCUPIED
				Unocc	UNOCCUPIED
NULL	NULL	OCCUPIED			
NULL	AUTO	ACTIVE	OCCUPIED	NA	OCCUPIED
			UNOCCUPIED	NA	BYPASS
			STANDBY	NA	BYPASS
			NULL	Occ	OCCUPIED
				Unocc	BYPASS
NULL	NULL	OCCUPIED			
NULL	AUTO	ACTIVE	NULL	NULL	OCCUPIED

Dirty Filter Notification

The MicroTech unit controller is programmed to provide a notification to change air filters. This notification can be configured to be based on supply fan runtime, a dirty filter switch input, or a combination of the two. This configuration is selected using the Filter Change Strategy parameter.

The polarity of the dirty filter switch input can be selected using the Filter Change Signal and Filter Change Status parameters.

NOTE: If the Filter Change Signal parameter is Normally Open and there is no device connected to the dirty filter switch input (TB2, 232A), this will disable the dirty filter switch input.

Remote Integrated Thermostat Operation

The remote integrated thermostat is an optional accessory that can be mounted in the space to adjust temperature settings and parameters. For units where the Control Temperature Source is Space, Average, or where the Supply Fan Control Strategy is Single Zone VAV, the Remote Integrated Thermostat is required.

For more technical information on the thermostat, consult Daikin Applied IM 1366.

Figure 13: Thermostat Display

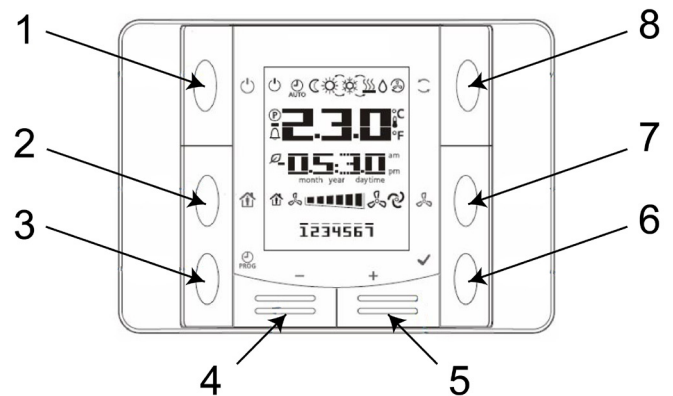

Table 6: Thermostat Buttons

Number	Name	Function
1	ON/OFF	Power on or power off
2	Presence	Enter or exit a programmed presence mode.
3	Program	Time Scheduler. Pressing this button adjusts date/time setting, while holding it allows schedule programming.
4	Minus	Setpoint adjustment. Each operation of the Minus (-) button reduces the setpoint by 0.1 °C/0.5°F or 0.5 °C/1.0°F which is defined in controller's setting.
5	Plus	Setpoint adjustment, each operation of the Plus (+) button increases the set point by 0.1 °C/0.5°F or 0.5 °C/1.0°F which is defined in controller's setting.
6	OK	Confirms date/time and scheduler settings.
7	Fan	Fan speed adjustment. The fan speed is set up in grades by the controller. By pressing the Fan button, the grades can be selected clockwise in a cyclical way. The current grade selected manually is indicated by the highlighted bar on the display.
8	Mode	Energy mode selection. The 3 energy modes are Auto, Comfort and Economy. By pressing the Mode button, the user can switch HMI-SG between the 3 modes in a cyclical way. The current mode manually selected is indicated by relevant symbol on the display.

Unit Set-Up

Table 7: Main Menu \ Commission Unit \ Unit Set-Up

Menu Display Name	Default	Range	Description
Eng Units=	English	SI	Eng Units is an adjustable item to indicate if the unit is to display English or Metric units of measure.
		English	
Ctrl Temp Src=	SPACE	SPACE	Control Temp Src is an adjustable item that selects the control temperature source from either a space, return air sensor, or the average temperature using both sensor inputs.
		RETURN	
		AVERAGE	
Ctrl Humidity Src=	SPACE	OUTDOOR	Control Humidity Src is an adjustable item that selects the control humidity source from either a space humidity, outdoor air humidity, or an average of the space and outdoor air humidity.
		SPACE	
		SPACE_OUTDOOR	

Timer Settings

Table 8: Main Menu \ Commission Unit \ Timer Settings

Menu Display Name	Default	Range	Description
Clg Stg Time=	0	0-600 Seconds	Clg Stg Time is an adjustable item which sets the minimum amount of time between bringing on/off stages of cooling.
Htg Stg Time=	0	0-600 Seconds	Htg Stg Time is an adjustable item which sets the minimum amount of time between bringing on/off stages of heating.
Tnt Ovrd Incr=	120	0-480 Minutes	Tnt Ovrd Incr is an adjustable item that sets the amount of time the unit will be in the bypass mode when initiated by a tenanat override input.
DSP Start Delay=	30	5-120 Seconds	DSP Start Delay is an adjustable item which sets the minimum amount of time after the VAV box output has been energized before the supply fan will be enabled. This applies to units where the SAF Control is DSP.
DSP Control Delay=	120	5-240 Seconds	DSP Start Delay is an adjustable item which sets the minimum amount of time after the supply fan has been enabled, that it will run at minimum speed before DSP control is commenced.
Comp Start Delay=	360	360-420 Seconds	Comp Start Delay is an adjustable item which sets the minimum amount of time after initial power up that the compressor must remain off. If this value is at the default of 360 and additional random value of 1-60 seconds will be added to this delay to prevent multiple units from turning on their compressors at the same time.
Comp Min Ena=	DISABLE	DISABLE ENABLE	Comp Min Ena is an adjustable item which enables or disables minimum compressor on/off timers.
Comp Min On=	180	60-600 Seconds	Comp Min On is an adjustable item which sets the minimum amount of time a compressor output must be on before it can be turned off.
Comp Min Off=	360	300-600 Seconds	Comp Min Off is an adjustable item which sets the minimum amount of time a compressor output must be off before it can be turned back on.

Menu Display Name	Default	Range	Description
Cond Delay=	60	0-120 Seconds	Cond Delay is an adjustable item which sets the amount of time the condensate overflow input must be active before a condensate overflow alarm will be triggered. This is to prevent nuisance indications of condensate.
EWT Retry=	120	10-600 Minutes	EWT Retry is an adjustable item which sets the amount of time that must pass after the entering water has been deemed inadequate for a mode of operation, before the controller will retry operation in that mode. This applies to 2 pipe chilled water/hot water changeover units only.
EWT Sample=	120	60-600 Seconds	EWT Sample is an adjustable item which sets the amount of maximum amount of time that the controller will sample the entering water temperature to determine if it is adequate for the desired mode of operation. This applies to 2 pipe chilled water/hot water changeover units only.

Supply Air Fan Set-Up Menu

For more details on Supply Air Fan control and setup, refer to "Supply Air Fan" on page 32.

Table 9: Main Menu \ Commission Unit \ SAF Set-up

Menu Display Name	Default	Range	Description
DSP CONTROL			
SAF Duct-Press=	-	0.0 in - 5.0 in	SAF Duct Press is a status only item that indicates the current value for the duct static pressure sensor.
SAF DSP Spt=	1.0 in	0.2 in - 4.0 in	SAF DuctSP Spt is an adjustable item which sets the supply fan duct static pressure setpoint. The SAF is modulated with a PI_Loop to maintain this setpoint.
SAF DSP DB=	0.25 in	0 in - 2.0 in	SAF DSP DB is an adjustable item which sets a dead band around the DuctSP Spt. No Duct static pressure control action is taken when the current duct static pressure input is within this deadband.
Min Cap=	20%	20% - 100%	Min Cap is an adjustable item which sets the minimum output value when the supply fan is operating.
Max Cap=	100%	20% - 100%	Max Cap is an adjustable item which sets the maximum output value when the supply fan is operating.

Menu Display Name	Default	Range	Description
DSP High Alarm =	4.5 IWC	2.0 - 5.0 IWC	DSP High Alarm is an adjustable item which sets the measured DSP value above which will trigger a DSP High Alarm.
DSP Error =	60 Seconds	60-360 Seconds	DSP Error is an adjustable item which sets the amount of time the measured DSP value must be above the DSP High Alarm value before a DSP High Alarm is triggered.
Fan Min Elect=	60%	60% - 100%	Fan Min Elect is an adjustable item which sets the minimum output value of the supply fan as a percentage of the electric heat capacity.
Air Flow Proving=	Uninstall	Uninstall Install	Air Flow Proving is an adjustable item which configures the controller to expect an input from an airflow proving switch.
Air Flow Delay=	10 Seconds	10-240 Seconds	Air Flow Delay is an adjustable item which sets the amount of time the supply air fan must be running before the application checks the status of the air flow proving switch input.

1 ZONE VAV CONTROL

Control Temp=	-	-40°F - 212°F	Control Temp is a status only item which displays the current value of the "Control Temperature." The "Control Temperature" is defined as the temperature input selected by the Control Temperature Source parameter.
Occ Clg Spt=	75°F	50°F - 95°F	Occ Clg Spt is a status only item which indicates the temperature in which the unit will go into the cooling mode of operation. Once a valid password has been entered this item becomes an adjustable item.
Occ Htg Spt=	70°F	50°F - 95°F	Occ Htg Spt is a status only item which indicates the temperature in which the unit will go into the heating mode of operation. Once a valid password has been entered this item becomes an adjustable item.
Occ DB =	0.0°F	0.0°F - 5.0°F	Occ DB is an adjustable item which sets a dead band around the Occ Cooling and Heating Setpoint parameter. For example, if the Occ Cooling Setpoint parameter is set to 75°F and the Occ DB parameter is set to 2°F the dead band around the setpoint would be from 76.0°F to 74.0°F.

Menu Display Name	Default	Range	Description
Min Cap=	20%	20% - 100%	Min Cap is an adjustable item which sets the minimum output value when the supply fan is operating.
Max Cap=	100%	20% - 100%	Max Cap is an adjustable item which sets the maximum output value when the supply fan is operating.
Fan Cycling=	ON	ON CYCLE	Fan Cycling is an adjustable item which configures the supply fan to be always on, or to cycle off when there's no demand, when the Occupancy is occupied or bypass.
Fan Min Elect=	60%	60% - 100%	Fan Min Elect is an adjustable item which sets the minimum output value of the supply fan as a percentage of the electric heat capacity.
Air Flow Proving=	Uninstall	Uninstall Install	Air Flow Proving is an adjustable item which configures the controller to expect an input from an airflow proving switch
Air Flow Delay=	10 Seconds	10-240 Seconds	Air Flow Delay is an adjustable item which sets the amount of time the supply air fan must be running before the controller checks the status of the air flow proving switch input.
CAV Control			
CAV Cap=	75%	20% - 100%	CAV Cap is an adjustable item which sets the supply air fan capacity when the supply fan is operating in any mode other than dehumidification.
Min Cap=	20%	20% - 100%	Min Cap is an adjustable item which sets the minimum output value when the supply fan is operating.
Max Cap=	100%	20% - 100%	Max Cap is an adjustable item which sets the maximum output value when the supply fan is operating.
Dehumid Cap=	50%	20% - 100%	Dehumid Cap is an adjustable item which sets the supply air fan capacity when the supply fan is operating in dehumidification.
Fan Cycling=			Fan Cycling is an adjustable item which configures the supply fan to be always on, or to cycle off when there's no demand, when the Occupancy is occupied or bypass.
Fan Min Elect=			Fan Min Elect is an adjustable item which sets the minimum supply air fan capacity as a percentage of the total electric heat output when any amount of electric heat is being provided.

Menu Display Name	Default	Range	Description
Air Flow Proving=	Uninstall	Uninstall Install	DSP High Alarm is an adjustable item which configures the application to expect an input from an airflow proving switch.
Air Flow Delay=	10 Seconds	10-240 Seconds	Air Flow Delay is an adjustable item which sets the amount of time the supply air fan must be running before the application checks the status of the air flow proving switch input.

Exhaust Fan Set-Up Menu

For more details on Exhaust Fan control and setup, refer to "Exhaust Fan" on page 32.

Table 10: Main Menu \ Commission Unit \ EF Set-Up

Menu Display Name	Default	Range	Description
EF Ctrl=	Disabled	Disabled Tracking Const_Speed	EF Ctrl is an adjustable item which configures exhaust fan speed control.
Min EF Cap=	-	0% - 100%	Min EF Cap is an adjustable item which sets the minimum output value when the exhaust fan is operating and EF Ctrl is Tracking.
Max EF Cap=	100%	0% - 100%	Max EF Cap is an adjustable item which sets the maximum output value when the exhaust fan is operating and EF Ctrl is Tracking.

Cooling Setup

Table 11: Main Menu \ Commission Unit \ Cooling Set-Up

Menu Display Name	Default	Range	Description
CW Valve Pos=	-	0%-100%	CW Valve Pos is a status only item which indicates the percentage that the modulating chilled water valve is currently open.
ChgOvr Valve Pos=	-	0% - 100%	ChgOvr Valve Pos is a status only item which indicates the percentage that the modulating changeover water valve is currently open.
CW Valve Pos=	-	INACTIVE	CW Valve Pos is a status only item which indicates the condition of the two position chilled water valve output.
		ACTIVE	
ChgOvr Valve Pos=	-	INACTIVE	ChgOvr Valve Pos is a status only item which indicates the condition of the two position changeover valve output.
		ACTIVE	
Comp Stg 1 =	-	INACTIVE	Comp Stg 1 is a status only item which indicates the condition of the compressor stage 1 output.
		ACTIVE	
Comp Stg 2 =	-	INACTIVE	Comp Stg 2 is a status only item which indicates the condition of the compressor stage 2 output.
		ACTIVE	
Comp Stg 3 =	-	INACTIVE	Comp Stg 3 is a status only item which indicates the condition of the compressor stage 3 output.
		ACTIVE	
Comp Stg 4 =	-	INACTIVE	Comp Stg 4 is a status only item which indicates the condition of the compressor stage 4 output.
		ACTIVE	
Control Temp=	-	-40°F - 212°F	Control Temp is a status only item which displays the current value of the "Control Temperature." The "Control Temperature" is defined as the temperature input selected by the Control Temperature Source parameter.
Occ Clg Spt=	75.0°F	50°F - 95°F	Occ Clg Spt is an adjustable item which affects the temperature at which the unit will go into the cooling mode of operation.
Occ Diff	1.0°F	1°F - 5°F	Occ Diff is an adjustable item which affects the temperature at which the unit will exit the cooling or heating mode of operation when Occupancy is occupied, bypass, or standby. This value will be subtracted from the cooling setpoint or added to the heating setpoint to determine when to exit the mode.

Menu Display Name	Default	Range	Description
Out Clg Spt=	80.0°F	50°F - 95°F	Out Clg Spt is an adjustable item which affects the temperature at which the unit will go into the cooling mode of operation when the Control Temperature source is Outdoor Air Temperature.
Out Diff=	1.0°F	1°F - 5°F	Out Diff is an adjustable item which affects the temperature at which the unit will exit the cooling or heating mode of operation when Control Temperature Source is Outdoor Air. This value will be subtracted from the cooling setpoint or added to the heating setpoint to determine when to exit the mode.
Disch Air=	-	-40°F - 212°F	Disch Air is a status only item which displays the current temperature reading from the unit's discharge air temperature sensor (DAT).
DAT Clg Spt=	55.0°F	45°F - 75°F	DAT Clg Spt is an adjustable item which sets the temperature that the DAT should be maintained at when it is in the cooling mode of operation. This point is only available on units that use discharge air temperature control.
DAT Clg DB=	1.0°F	1.0°F - 10.0°F	DAT Clg DB is an adjustable item which sets a dead band around the DAT Clg Spt parameter. For example, if the DAT Clg Spt parameter is set to 55°F and the DAT Clg DB parameter is set to 1°F the dead band around the setpoint would be from 55.5°F to 54.5°F.
EffSpaceT=	-	-40°F - 212°F	EffSpaceT is a status only item which displays the current space temperature value being used by the controller. This will be the network supplied space temperature if available or the input from the integrated thermostat.
Return Temp=	-	-40°F - 212°F	Return Air is a status only item which displays the current temperature reading from the unit's return air temperature sensor (RAT).
Unocc Clg Spt=	85.0°F	40.0°F - 100.0°F	Unocc Clg Spt is an adjustable item which sets the control temperature below which the unit starts up and provides unoccupied cooling (night setback) during unoccupied periods.

Menu Display Name	Default	Range	Description
Unocc Diff=	2°F	1°F - 10°F	Unocc Diff is an adjustable item which affects the temperature at which the unit will exit the cooling or heating mode of operation when Occupancy is unoccupied. This value will be subtracted from the cooling setpoint or added to the heating setpoint to determine when to exit the mode.
StdBy Clg Spt=	77°F	50°F - 95°F	Stdby Clg Spt is a status only item which indicates the temperature in which the unit will go into the cooling mode of operation in the standby occupancy state. Once a valid password has been entered this item becomes an adjustable item.
Clg Stg Time=	0 Sec-onds	0-600 Sec-onds	Clg Stg Time is an adjustable item which sets the minimum amount of time between bringing on/off stages of cooling.
Clg Stg Timer=	0 Sec-onds	0-600 Sec-onds	Clg Stg Timer is a status only item which displays the amount of time remaining before the heating stage timer expires.
OA Temp=	-	-40°F - 212°F	OA Temp is a status only item which displays the current temperature value being used by the controller. This will be the network supplied space temperature if available or the input from the outdoor air temperature sensor.
Clg Lo OAT Lk=	36°F	25°F - 60°F	Clg Stg Time is an adjustable item which sets the outdoor air temperature below which the outdoor air damper will be closed if OAT Lockout Ena is Enabled.

Dehumidification Set-Up

Table 12: Main Menu \ View Status \ Dehum Set-up

Menu Display Name	Default	Range	Description
Dehum Method=	DEWPT	REL_HUM DEWPT	Dehum Method is an adjustable item which configures dehumidification will be enabled based on a space relative humidity setpoint or a space dewpoint setpoint.
Dehum Control=	NONE	NONE PASSIVE ACTIVE PRIMARY	Dehum Control is an adjustable item which configures the controller to use active, passive, or no dehumidification.

Menu Display Name	Default	Range	Description
Hum Src=	SPACE	SPACE OUTDOOR SPACE_OUTDOOR	Hum Src is an adjustable item that selects the control humidity source from either a space humidity, outdoor air humidity, or an average of the space and outdoor air humidity.
Rel Hum=	-	0% - 100%	Rel Hum is a status only item that indicates the current space relative humidity value being used by the controller. This will be the network supplied relative humidity if available or the input from the space relative humidity sensor.
Hum Spt=	60%	20% - 100%	Hum Spt Spt is an adjustable item which indicates the space relative humidity above which the unit will go into the dehumidification mode of operation, if available.
Hum Diff=	5%	1% - 10%	Hum Spt Spt is an adjustable item which sets the differential below the Hum Spt where the controller will disable dehumidification.
Dewpoint =	-	0°F - 100°F	Dewpoint is a status only item that indicates the current calculate space relative dewpoint value being used by the controller.
Dewpnt Spt=	55°F	45°F - 70°F	Dewpnt Spt is an adjustable item which indicates the space dewpoint setpoint above which the unit will go into the dehumidification mode of operation, if available.
Dewpnt Diff=	2°F	1°F - 10°F	Dewpnt Diff is an adjustable item which sets the differential below the Dewpnt Spt where the controller will disable dehumidification.
LCT Setpoint=	55.0°F	45°F - 70°F	LCT Setpoint is an adjustable item which is used to set the leaving coil temperature setpoint the compressors control to maintain during dehumidification operation.
DAT Clg Spt=	55.0°F	45°F - 75°F	DAT Clg Spt is an adjustable item which sets the temperature that the DAT should be maintained at when it is in the cooling mode of operation. This point is only available on units that use discharge air temperature control
DAT Clg DB=	1.0°F	1.0°F - 10.0°F	DAT Clg DB is an adjustable item which sets a dead band around the LCT Setpoint parameter. For example, if the LCT Setpoint parameter is set to 55°F and the DAT Htg DB parameter is set to 1°F the dead band around the setpoint would be from 55.5°F to 54.5°F.

Menu Display Name	Default	Range	Description
DAT Htg DB=	1.0°F	1.0°F - 10.0°F	DAT Htg DB is an adjustable item which sets a dead band around the Dehum DAT Sp parameter. For example, if the Dehum Spt parameter is set to 70°F and the DAT Htg DB parameter is set to 1°F the dead band around the setpoint would be from 70.5°F to 74.5°F.
Dehum DAT Sp=	70.0°F	55.0°F - 80.0°F	Dehum DAT Sp is an adjustable item which sets the temperature that the DAT should be maintained at when it is in the dehumidification mode of operation

Heating Set-Up Menu

Table 13: Main Menu \ Commission Unit \ Heating Set-Up

Menu Display Name	Default	Range	Description
Control Temp=	-	-40-212°F	Control Temp is a status only item which displays the current value of the "Control Temperature." The "Control Temperature" is defined as the temperature input selected by the Control Temperature Source parameter.
HW Valve Pos=	-	0% - 100%	HW Valve Pos is a status only item which indicates the percentage that the hot water valve is currently open
HW Valve Pos=	-	INACTIVE ACTIVE	HW Valve Pos is a status only item which indicates the condition of the two position hot water valve output.
Htg Stg 1 =	-	INACTIVE ACTIVE	Htg Stg 1 is a status only item which indicates the condition of the electric heat stage 1 output.
Htg Stg 2 =	-	INACTIVE ACTIVE	Htg Stg 2 is a status only item which indicates the condition of the electric heat stage 2 output.
Htg Stg 3 =	-	INACTIVE ACTIVE	Htg Stg 3 is a status only item which indicates the condition of the electric heat stage 3 output.
Htg Stg 4 =	-	INACTIVE ACTIVE	Htg Stg 4 is a status only item which indicates the condition of the electric heat stage 4 output.
SCR Output=	-	0% - 100%	SCR Output is a status only item which indicates the current capacity of the SCR electric heater.
Occ Htg Spt=	70.0°F	0.0°F - 100.0°F	Occ Htg Spt is an adjustable item which affects the temperature at which the unit will go into the heating mode of operation.

Menu Display Name	Default	Range	Description
Occ Diff=	1°F	1°F - 5°F	Occ Diff is an adjustable item which affects the temperature at which the unit will exit the cooling or heating mode of operation when Occupancy is occupied, bypass, or standby. This value will be subtracted from the cooling setpoint or added to the heating setpoint to determine when to exit the mode.
Out Htg Spt=	55.0°F	45°F - 70°F	Out Htg Spt is an adjustable item which affects the temperature at which the unit will go into the heating mode of operation when the Control Temperature source is Outdoor Air Temperature.
Out Diff=	1.0°F	1°F - 5°F	Out Diff is an adjustable item which affects the temperature at which the unit will exit the cooling or heating mode of operation when Control Temperature Source is Outdoor Air. This value will be subtracted from the cooling setpoint or added to the heating setpoint to determine when to exit the mode.
Disch Air=	-	-40°F - 212°F	Disch Air is a status only item which displays the current temperature reading from the unit's discharge air temperature sensor (DAT).
DAT Htg Spt=	80°F	75°F - 120°F	DAT Htg Spt is an adjustable item which sets the temperature that the DAT should be maintained at when it is in the heating mode of operation. This point is only available on units that use discharge air temperature control.
Vlv Htg DB=	1.0°F	1.0°F - 10.0°F	Vlv Htg DB is an adjustable item which sets a dead band around the DAT Htg Spt parameter. For example, if the DAT Htg Spt parameter is set to 80°F and the Vlv Htg DB parameter is set to 1°F the dead band around the setpoint would be from 80.5°F to 79.5°F.
EI Htg DB=	1.0°F	1.0°F - 10.0°F	EI Htg DB is an adjustable item which sets a dead band around the DAT Htg Spt parameter. For example, if the DAT Htg Spt parameter is set to 80°F and the EI Htg DB parameter is set to 1°F the dead band around the setpoint would be from 80.5°F to 79.5°F.
EffSpaceT=	-	-40°F - 212°F	EffSpaceT is a status only item which displays the current space temperature value being used by the controller. This will be the network supplied space temperature if available or the input from the integrated thermostat.

Menu Display Name	Default	Range	Description
Return Temp=	-	-40°F - 212°F	Return Air is a status only item which displays the current temperature reading from the unit's return air temperature sensor (RAT).
Unocc Htg Spt=	60°F	50°F - 95°F	Unocc Htg Spt is an adjustable item which sets the control temperature below which the unit starts up and provides unoccupied heating (night setup) during unoccupied periods.
Unocc Diff=	2°F	0°F - 10°F	Unocc Diff is an adjustable item which affects the temperature at which the unit will exit the cooling or heating mode of operation when Occupancy is unoccupied. This value will be subtracted from the cooling setpoint or added to the heating setpoint to determine when to exit the mode.
StdBy Htg Spt=	66.0°F	50°F - 95°F	StdbY Htg Spt is a status only item which indicates the temperature in which the unit will go into the heating mode of operation in the standby occupancy state. Once a valid password has been entered this item becomes an adjustable item.
Htg Stg Time=	0 Seconds	0-600 Seconds	Htg Stg Time is an adjustable item which sets the minimum amount of time between bringing on/off stages of heating.
Htg Stg Timer=	0 Seconds	0-600 Seconds	Htg Stg Timer is a status only item which displays the amount of time remaining before the heating stage timer expires.
OA Temp=	-	-40°F - 212°F	OA Temp is a status only item which displays the current temperature value being used by the controller. This will be the network supplied space temperature if available or the input from the outdoor air temperature sensor.
Ent Unit Spt=	20°F	10°F - 40°F	Ent Unit Spt is an adjustable item which affects the entering unit temperature target used for staging pre-heat when preheat is required.
Ent Unit Diff=	10°F	1°F - 20°F	Ent Unit Diff is an adjustable item which affects the temperature at which the unit will exit the preheat state for staged preheat applications.

OA Damper Set-Up

Table 14: Main Menu \ Commission Unit \ OA Damper Set-Up

Menu Display Name	Default	Range	Description
OAD Positon=	-	0% - 100%	OAD Position is a status only item which displays the current OAD position.
Min OA Pos=	20%	0% - 100%	Min OA Pos is an adjustable item which indicates the minimum position of the outdoor damper while the fan is running. The actual OAD damper position will vary between this value and the Max OA Pos depending on economizer and DCV requirements.
Max OA Pos=	100%	0% - 100%	Max OA Pos is an adjustable item which indicates the maximum position of the outdoor damper while the fan is running. The actual OAD damper position will vary between this value and the Min OA Pos depending on economizer and DCV requirements.

Econo Set-Up Menu

Table 15: Main Menu \ Commission Unit \ Econo Set-Up Menu

Menu Display Name	Default	Range	Description
Control Temp=	-	-40°F - 212°F	Control Temp is a status only item which displays the current value of the "Control Temperature." The "Control Temperature" is defined as the temperature input selected by the Control Temperature Source parameter.
Occ Clg Spt=	75°F	50°F - 95°F	Occ Clg Spt is an adjustable item which affects the temperature at which the unit will go into the cooling mode of operation.
Occ Diff=	1°F	1°F - 5°F	Occ Diff is an adjustable item which affects the temperature at which the unit will exit the cooling or heating mode of operation when Occupancy is occupied, bypass, or standby. This value will be subtracted from the cooling setpoint or added to the heating setpoint to determine when to exit the mode.
Out Clg Spt=	80.0°F	50°F - 95°F	Out Clg Spt is an adjustable item which affects the temperature at which the unit will go into the cooling mode of operation when the Control Temperature source is Outdoor Air Temperature.

Menu Display Name	Default	Range	Description
Out Diff=	1.0°F	1°F - 5°F	Out Diff is an adjustable item which affects the temperature at which the unit will exit the cooling or heating mode of operation when Control Temperature Source is Outdoor Air. This value will be subtracted from the cooling setpoint or added to the heating setpoint to determine when to exit the mode
Disch Air=	-	-40°F - 212°F	Disch Air is a status only item which displays the current temperature reading from the unit's discharge air temperature sensor (DAT).
EffSpaceT=	-	-40°F - 212°F	EffSpaceT is a status only item which displays the current space temperature value being used by the controller. This will be the network supplied space temperature if available or the input from the integrated thermostat.
Return Temp=	-	-40°F - 212°F	Return Air is a status only item which displays the current temperature reading from the unit's optional return air temperature sensor (RAT).
OA Temp=	-	-40°F - 212°F	OA Temp is a status only item which displays the current temperature value being used by the controller. This will be the network supplied space temperature if available or the input from the outdoor air temperature sensor.
Max OAT Lmt=	75.0°F	50.0°F - 100.0°F	Max OAT Lmt is an adjustable item which sets the maximum outdoor air temperature for the applicable climate zone above which economizer should not be enabled.
Min OAT Lmt=	70.0°F	50.0°F - 100.0°F	Min OAT Lmt is an adjustable item which sets the minimum outdoor air temperature for the applicable climate zone below which economizer should be enabled.
Cal State=	-	NoCAL Cal Pass Fail	Cal State is a status only item which indicates the results of calibration process.
Calibrate OAD=	NO	NO YES	Calibrate OAD is an adjustable item used to initiate the calibration function that captures the command position at which the outdoor damper position end switches open and close at the closed and open ends of the damper modulation range.

Menu Display Name	Default	Range	Description
Pos Sw Open=	100%	0% - 100%	PosSwOpen is an item that indicates the captured command position at which the outdoor damper position end switch closes at the open end of the damper modulation range. This parameter can also be manually adjusted.
Max Sw Diff=	1%	0% - 50%	Max Sw Diff is an item that indicates the captured switch differential at the open (maximum) end of the damper modulation. This parameter can also be manually adjusted.
Pos Sw Close=	0%	0% - 100%	PosSwClose is an item that indicates the captured command position at which the outdoor damper position end switch closes at the closed end of the damper modulation range. This parameter can also be manually adjusted.
Min Sw Diff=	1%	0% - 50%	Min SW Diff is an item that indicates the captured switch differential at the closed (minimum) end of the damper modulation. This parameter can also be manually adjusted.
OAD Sw Status=	-	OPEN CLOSED	OAD Sw Status is a status only item that indicates the current condition of the damper end switch position input (Open/Closed).
Calibration Status=	OFF	OFF INCR_OPEN DECR_CLOSE INCR_OPEN_DIFF_IN-CR_100PCT DECR_OPEN INCR_CLOSED DECR_OPEN_DIFF DECR_OPCT	Calibration Status is a status only item that indicates the current step of the OAD end switch calibration process.
OAD Position Cal=	-	0% - 100%	OAD Position Cal is a status only item that indicates the OA damper position being commanded as part of the end switch calibration process.
Econ Src=	NONE	NONE OAT ENTHAL-PY_OUT TEMP_DIFF ENTHAL-PY_DIFF	Econ Src is an adjustable item which sets the strategy that will be used to determine if the outdoor air is suitable for economizing.

Menu Display Name	Default	Range	Description
OARelHum=	-	0% - 100%	OARelHum is a status only item which indicates the current outdoor relative humidity value being used by the controller. This will be the network supplied relative humidity if available or the input from the outdoor relative humidity sensor.
OAEnthalpy=	-	-200 to 200 BTU/lb	OAEnthalpy is a status only item which indicates the current calculated space enthalpy.
RARelHum=	-	0% - 100%	RARelHum is a status only item which indicates the current outdoor relative humidity value being used by the controller. This will be the network supplied relative humidity if available or the input from the return relative humidity sensor.
SpaceDwPnt=	-	0°F - 100°F	SpaceDwPnt is a status only item which indicates the current calculated space dewpoint.
SpaceRelHum=	-	0% - 100%	RARelHum is a status only item which indicates the current outdoor relative humidity value being used by the controller. This will be the network supplied relative humidity if available or the input from the return relative humidity sensor.
SpaceEnthalpy=	-	-200 - 200 BTU/lb	SpaceEnthalpy is a status only item which indicates the current calculated space enthalpy.
Control Hum=	-	0% - 100%	Control Hum is a status only item which indicates the current control relative humidity. The "Control Relative Humidity" is defined as the temperature input selected by the Control Humidity Source parameter.
Control Dewpt=	-	0°F - 100°F	Control Dewpt is a status only item which indicates the current calculated control dew point. The "Control Relative Dew Point" is defined as the temperature input selected by the Control Humidity Source parameter.
Control Enthalpy=	-	-200 - 200 BTU/lb	Control Enthalpy is a status only item which indicates the current calculated control enthalpy. The "Control Enthalpy" is defined as the temperature input selected by the Control Humidity Source parameter.
Outdoor Dewpt=	-	0°F - 100°F	Outdoor Dewpt is a status only item which indicates the current outdoor air dew point.

Air Filter Set-Up

Table 16: Main Menu \ Commission Unit \ Air Filter Set-Up

Menu Display Name	Default	Range	Description
Filter Chg Strategy=	NONE	NONE	Filter Chg Strategy is an adjustable item which selects if and when a dirty filter warning will be indicated.
		RUNTIME	
		BINARY_INPUT	
		BOTH	
Filter Chg Time=	1440 Hours	360 – 4320 Hours	Filter Chg Time is an adjustable item which sets the incremental supply fan run hours that must occur before a dirty filter warning will be indicated when the Filter Chg Strategy is BINARY_INPUT or BOTH.
Filter Chg Sig=	NORM_CLOSED	NORM_OPEN	Filter Chg Sig is an adjustable item which selects if the dirty filter binary input is expecting a normally open, or normally closed signal. If nothing is wired to the binary input and NORM_OPEN is selected, this feature is effectively disabled.
		NORM_CLOSED	
Filter Chg Status=	-	OPEN	Filter Chg Status is a status only item that indicates the current condition of the dirty filter switch input.
		CLOSED	
Filter Status=	-	GOOD	Filter Status is a status only item that indicates the current calculated condition of the air filter based on the Filter Chg Strategy parameter criteria.
		DIRTY	

View Status

Scheduling

The unit can be scheduled for operation by using the following three methods:

- Unit internal time scheduling functions
- External time clock function
- Network time scheduling function

Provided the unit is not locally or remotely disabled, the unit operates when any of these scheduling functions is calling for occupied operation. Conversely, the unit enters the unoccupied mode when all of these scheduling functions are calling for unoccupied operation. Therefore, any unused scheduling functions should be set for continuous unoccupied operation.

The next four sections: “Date and Time,” “Internal Daily Scheduling,” “Holiday Scheduling,” and “One Event Scheduling” describe functions related to the internal unit scheduling functions. These are followed by a section describing the optimal start function which can be used with internal scheduling and network scheduling. This is followed by two sections that describe the external time scheduling and network time scheduling functions.

Date and Time

The controller uses the Date and Time to execute its internal scheduling functions. The current Time and Date will not be lost if the unit is turned off for up to forty-eight hours. The Time and Date are set from the keypad. The Time of day can be set by entering the hour (00-23), minute (00-59), and second (00-59) into three fields of the Current Time. Note that MicroTech unit controller uses “military” time. The current Date can be set by entering the day (00-31), month (01- 12) and year (1999-2155) into the three fields of the Current Date.

Internal Daily Scheduling

An Internal Daily Schedule provides one start time and one stop time for each of the seven days of the week and for holidays. When the Occ Mode= parameter is set to “Auto/Net”, and the unit is not disabled for other reasons, it starts and stops according to the controller internal schedule.

Holiday Scheduling

The operator may select the days when start and stop times for holidays are used by selecting a start date and an end date for up to ten periods during the year using the Holiday Scheduling feature. Whenever a holiday period occurs, the controller uses the Holiday Schedule start and stop time for the period. For example, assume that Christmas Eve occurs on a Thursday. The building is shut down on both Christmas Eve and Christmas Day, but operates normally on the weekend. This holiday period would be scheduled by setting the Holiday Schedule to the default “no schedule” values “HH:MM- HH:MM” and setting the Holiday Period to “12/24/19 - 12/25/19

One Event Scheduling

One Event Scheduling is provided so that the operating period for a unique day can be scheduled without affecting the regular internal daily and holiday schedules. A start date/time and an end date/time can be set. The unit can be scheduled to operate during a specified period by using this feature. During the day’s period defined by the One Event Beginning Date and One Event Ending Date parameters, the unit starts up and runs continuously from the time period defined by the One Event Beginning Time until the One Event Ending Time, regardless of internal daily or holiday schedules.

Unit State

The Unit State can operate in one of seven operational states based on the control temperature source, (Ctrl Temp Src), selected in the HtgClg ChngOvr set up menu, a sensor will drive the unit into the correct state of the states - Heating, Cooling, Economizer, Econo-Cooling, Dehumidification, and Fan Only.

The current state will be displayed by the Unit State parameter in the Main Menu/Quick Menu, or the Main Menu/ViewStatus/Unit Status/Settings Menu

Neither heating or cooling is provided when the unit is in the Fan Only state.

Figure 14: Unit State Diagram

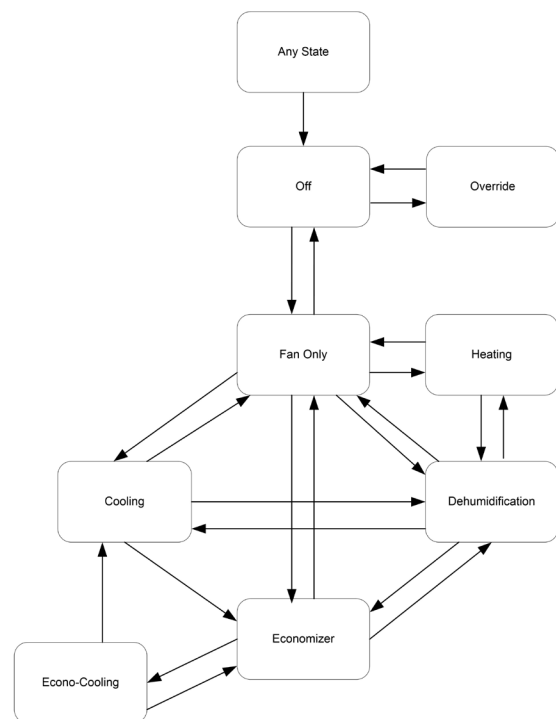

Off

In the OFF operating state the fans are off, the outsider air dampers are closed and cooling and heating are disabled. The unit is in the OFF state when it is not enabled, or when it is in

unoccupied mode with no call for unoccupied operation.

Fan Only

The unit enters the Fan Only operating state after power up and anytime there is no requirement for heating, cooling, or dehumidification. The outdoor air dampers are open to the minimum position in this state. Based on the control temperature source (Ctrl Temp Src), selected in the HtgClg ChngOvr set up menu, a sensor will drive the unit into one of the states - Heating, Cooling, Economizer, Econo-Cooling, Dehumidification, and Fan Only.

Cooling

The unit enters the Cooling operating state when cooling is required and the economizer is disabled, not present, or already fully open. Cooling operation can be mechanical DX compressors or chilled water coils.

- The transition to cooling will occur when the following are true:
 - The control temperature rises above the active cooling setpoint. The unit will exit the cooling state when the control temperature falls below the active cooling setpoint minus the occupied/unoccupied off differential.
 - The economizer operation is disabled or not present.

Economizer

If the unit is equipped with a 0% - 100% modulating Economizer and the conditions are suitable for free cooling, the unit attempts to satisfy the cooling load by using outdoor air before using mechanical cooling. Suitability for Economizer operation is determined by drybulb, comparative drybulb, or comparative energy/enthalpy. See “Economizer” on page 43 for details.

- The transition to Economizer will occur when the following are true:
 - The control temperature rises above the active cooling setpoint. The unit will exit the economizer state when the control temperature falls below the active cooling setpoint minus the occupied/unoccupied off differential or if the economizer is disabled.
 - The economizer operation is not disabled
- Dehumidification: When a unit is operating in dehumidification, dehumidification must finish operation and transition to cooling before the unit will enter economizer

Dehumidification

Dehumidification is activated based on a selectable humidity or dewpoint sensor input. Dehumidification can be initiated based on humidity measurements in the space, outdoor air, or both based on the Dehumidification Source configuration.

Heating

The unit enters the Heating operating state when the control temperature falls below the Occupied or Unoccupied Heating Setpoint. During the Heating operating state, the outdoor air dampers are controlled to the minimum outside air position.

Heating/Cooling Changeover

Control Temperature Source

When the control temperature is below the Occupied, Standby, or Unoccupied Heating Setpoint (point A), heating operation is enabled. Heating operation then remains enabled until the control temperature begins to rise and rises above the Occupied, Standby, or Unoccupied Heating Setpoint by more than the occupied off differential (for occupied/standby mode) or unoccupied off differential (for unoccupied mode) (point B), at which point heating operation is disabled and the unit enters the fan only operating state. If the control temperature rises above the Occupied, Standby, or Unoccupied Cooling Setpoint (point C) cooling operation is enabled. Cooling operation remains enabled until the control temperature begins to fall below the Occupied, Standby, or Unoccupied Cooling Setpoint by more than the occupied off differential (for occupied/standby mode) or unoccupied off differential (for unoccupied mode) (point D), at which point the unit returns to fan only operating state.

When the Control Temperature Source is Outdoor Air Temperature, the unit will only run in the Occupied mode using the Outdoor Cooling and Heating setpoints and the Outdoor Off Differential. Occupied, Standby, and Unoccupied setpoints will not be used for mode determination.

Figure 15: Heating/Cooling Control Temperature

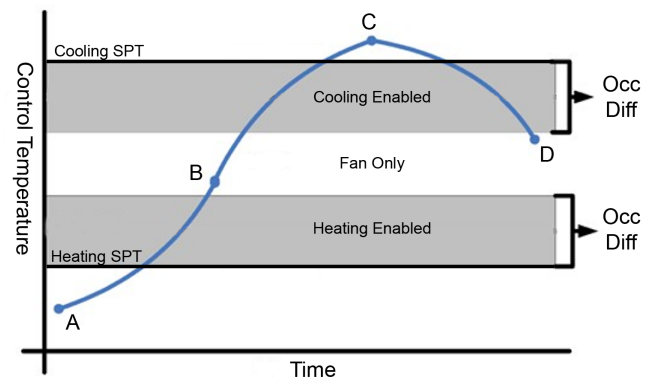

The “Control Temperature” is defined as the unit temperature input used to make the heat/cool changeover decision. This determines whether or not cooling or heating is enabled. The Control Temperature Source (Cntrl Temp Src) can be selected as Space, RAT (return air temperature), Average (which will use an average of the space and return air temperature values), or OAT (outdoor air temperature). The control temperature source selected will vary by application and temperature control configuration.

Space Setpoint Adjustment

The user has the option of using a space mounted remote sensor with setpoint adjustment functionality to control the setpoint of the space being controlled. See “Remote Integrated Thermostat Operation” on page 20 for more information.

NOTICE

Remote Integrated Thermostat space setpoint adjustment has no effect when the Control Temperature Source is OAT.

Supply Air Fan

Supply Air Fan Operation

NOTICE

For information on configuration, refer to page 22.

For information on advanced setup, refer to page 56.

The standard supply fans will be controlled using a single 0-10VDC analog capacity output.

The supply fans will control between an adjustable minimum and maximum fan capacity. The range is adjustable from 0% - 100%.

The supply fan will always be running before heating or cooling is activated.

If the unit is configured for electric heat, the fan will remain on for a minimum 30 seconds after all electric heat outputs have been de-energized.

If the unit is configured for an optional Airflow Proving Switch digital input, after the fan has been commanded to operate and Air Flow Startup Delay timer has expired, the controller will monitor the input. If the input indicates that the fan is not operating for 30 consecutive seconds the unit will go into an alarm state and shutdown.

When the unit is in unoccupied mode, the fan will be off when there's no demand, and the fan will cycle on with demand when operation is required.

Supply Air Fan Control Types

Constant Speed

When fan operation is required, the supply fan 0-10VDC output will drive the fan to run at scaled % output set by the end user. If the unit is configured to support dehumidification, when dehumidification is required, the supply fan 0-10VDC output will drive the fan to run at scaled % output for the Supply Fan Dehumidification Speed Setpoint set by the user. The Constant and Dehumidification fan speeds can be set to the same value, if desired.

Single Zone VAV Control (1ZnVAV)

Single Zone VAV control operates the unit as a single VAV box. The cooling and heating are controlled to maintain a discharge air temperature setpoint and the supply fan is modulated to maintain the appropriate space temperature setpoint. If the Control Temperature Source is Outdoor Air Temperature and the fan speed control is Single Zone VAV, a space temperature sensor will still be required to modulate the supply fan.

Duct Pressure Control (DSP)

Duct pressure control operates the unit to maintain the supply duct conditions. The cooling is controlled to maintain a discharge air temperature setpoint and the supply fan is modulated to maintain a supply duct static pressure setpoint. The duct pressure setpoint can be adjusted at the unit controller interface or via a network input signal.

Using the Fan Cycling Configuration, the supply fan can be configured to be always on when in the occupied state or to cycle on/off with demand. If Fan Cycling Configuration is set to "On" and the unit is in the occupied mode, the fan will be at the Supply Fan Minimum Speed when there is no heating or cooling demand.

When fan operation is required, the Zone Damper Output will first be energized and the DSP Startup Delay timer will begin to count down. The supply fan will not be allowed to run until the DSP Startup Delay Timer has expired. When fan operation is required, the fan will initially run at minimum speed for the duration of the DSP Control Delay timer. The supply fan output will be controlled by a field adjustable control loop monitoring the Duct Static Pressure input to maintain it at the Duct Static Pressure Setpoint.

Exhaust Fan

NOTICE

For information on configuration, refer to page 23.

For information on advanced setup, refer to page 57.

Units have the option of being equipped with one or more exhaust fans. When equipped, each exhaust fan will be controlled by a single 0-10VDC analog capacity value. The exhaust fan will be controlled between adjustable minimum and maximum fan capacity.

Exhaust Fan Control Types

Constant Speed

When the Exhaust Fan Control is set to Constant Speed, the exhaust fan will be controlled to the Exhaust Fan Constant Speed Setpoint.

Fan Tracking Control (Tracking)

When the Exhaust Fan Control is set to Tracking the exhaust fan capacity is varied to maintain an adjustable offset between the Exhaust Fan capacity and the Supply Fan capacity. The user specifies the offset at maximum and maximum supply fan capacity and the Exhaust Fan controls linearly between the two points.

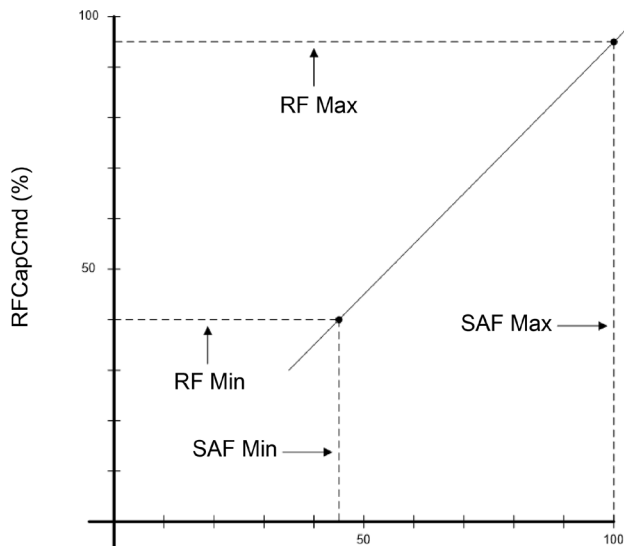
Figure 16: Exhaust Fan Tracking

The field process for setting these parameters will be as follows:

1. With the unit running and the outdoor air dampers at minimum position (in Fan Only State for example), the VAV box system will be manipulated to simulate a call for maximum airflow.
2. The supply air fan will be allowed to stabilize (normally under DSP control) and the Supply Fan Maximum Speed parameter will be set to the steady-state SAF Capacity value.
3. The Exhaust Fan at Supply Fan Max value will then be adjusted until the desired building pressure is obtained (usually slightly positive).
4. The VAV Box system will then be manipulated to simulate call for minimum airflow.
5. The supply air fan will be allowed to stabilize (normally under DSP control) and the Supply Fan Maximum Speed Parameter will be set to the steady-state SAF Capacity value.
6. The Exhaust Fan at Supply Fan Minimum Value will be adjusted until the desired building pressure is obtained (generally slightly positive).

NOTICE

Ideally the minimum and maximum conditions should be checked with the outdoor dampers at minimum and maximum positions to assure there are not significantly different requirements depending on the outdoor damper position. If the differences are significant then the parameters may be manually adjusted to compromise between the two conditions. If the differences are too great, it may be necessary to change to building pressure RAF/EAF control for the application.

NOTICE

Setting the minimum and maximum tracking points will not necessarily establish minimum and maximum SAF modulation ranges, but rather simply establishes the slope of the tracking curve. The curve line will be projected up to effective max SAF capacity and down to the effective minimum SAF capacity.

Network Control

The Network Exhaust Fan Enable Input can be used by a building management system to enable/disable the exhaust fan.

Outdoor Air Damper Control (OAD)

When the unit is equipped with a exhaust fan, the Exhaust Fan Min Damper Position parameter can be used to disable exhaust fan operation when the OA damper position is below the Exhaust Fan Min Damper Position value.

Cooling

Staged Compressors

In units equipped with staged compressors that are configured for Constant Speed supply fan control, the compressors stage on and off to maintain the control temperature (Space, RAT, or an average of the two). The control temperature being maintained is the occupied or unoccupied cooling setpoint.

When Compressor Stages is 1, when cooling is required, the compressor 1 output will be energized. If Compressor Stages is 2, the compressor 2 output will be energized when the control temperature reaches the active cooling setpoint plus the compressor cooling differential. If the Compressor 2 output is energized and the control temperature falls below the active cooling setpoint + Compressor Cooling Differential – Unoccupied Off Differential, then Compressor 2 output will de-energize.

When Compressor Stages is 4, the controller will use a PID control to stage the 4 compressor stages.

If the Supply Fan Control is “Constant Speed”, the PID loop will stage to control the control temperature. If the Supply Fan Control is “Duct Static Pressure” or “Single Zone VAV” the PID loop will stage to control discharge air temperature to the Cooling Discharge Air Temperature Setpoint.

The compressor outputs Compressor 1, Compressor 2, Compressor 3, and Compressor 4 each represent 25% of the cooling capacity.

- When cooling output is >0% Compressor 1 will be energized and it will be de-energized when the cooling output is 0%.
- When cooling output is >25% Compressor 2 will be energized and it will be de-energized when the cooling output is 20%.
- When cooling output is >50% Compressor 3 will be energized and it will be de-energized when the cooling output is 45%.
- When cooling output is >75% Compressor 4 will be energized and it will be de-energized when the cooling output is 70%.

For all compressor configurations, when mechanical cooling is no longer required, it will be de-energized. Additionally, when a stage of cooling is energized/de-energized, the interstage timer will start and the next stage of cooling will not be brought on/off until the interstage timer expires.

D-Kit Compressor

When cooling is required, the variable speed compressor will control to the Cooling Discharge Air Temperature setpoint.

Minimum Compressor On/Off Time

When the Compressor Minimum On/Off Configuration is Enabled, the MicroTech unit controller will use minimum On and Off timers when staging the compressor outputs. When a compressor is turned off, it must remain off for the duration of the Compressor Minimum Off Time. When a compressor is turned on, it must remain on for the duration of the Compressor Minimum On Time. If the Compressor Minimum On/Off Configuration is disabled, the Compressor Minimum On Time and Compressor Minimum Off Time will not be used when turning on and off any compressor outputs.

After initial power up of the controller, clearing of a fault, or transition from Unoccupied, all compressors must remain off for the duration of the Compressor Minimum Off Time plus a randomly generated value of up to 60 additional seconds. This prevents multiple units from turning on compressors at the same time when power is applied.

Lead Compressor Selection

If Lead Compressor Configuration is Run Hours, when a compressor is needed to satisfy the cooling requirement, the controller will bring on the compressor with the lowest total runtime. If Lead Compressor Configuration is Compressor 1, when a compressor is needed to satisfy the cooling requirement, the controller will bring on the compressors in numerical order. Compressors will be turned off in the reverse order that they were turned on. Lead Compressor selection does not apply to the D-Kit Configuration.

Valve Control

Two-Position Chilled Water Valve

In units equipped with a two-position chilled water valve, when cooling is required, the chilled water valve will be open. When cooling is no longer required the chilled water valve will be closed.

Modulating Chilled Water Valve

In units equipped with a modulating chilled water valve, the controller will use PI control to modulate the valve open and closed.

If the Supply Fan Control is "Constant Speed", the PI loop will modulate to control to space temperature. If the Supply Fan Control is "Duct Static Pressure" or "Single Zone VAV" the PI loop will modulate to control discharge air temperature to the Cooling Discharge Air Temperature Setpoint.

Heating

Heating Operation

A unit may be configured with one of several optional types of primary Heating: Hot Water, Steam, or Electric Heat. The options will either be staged or modulating controlled. The unit enters the Heating operating state from the Fan Only operating state when the control temperature falls below the Occupied or Unoccupied Heating Setpoint. The unit transitions from the Heating to Fan Only operating state when the control temperature rises above the Occupied or Unoccupied Heating Set Point plus the Occupied or Unoccupied Off Differential.

Single Stage Electric Heat / Two-Position ON/OFF Hot Water Valve

When heating is active, the Electric Heat will be On or the hot water valve will be open. Electric Heat staging is subject to the Heating Interstage Timer. When heating is no longer required, the electric heat will be Off or the hot water valve will be closed.

Four Stage Electric Heat

The electric heat outputs will each represent 25% for the heating capacity.

- When heating output is >0% Heat Stage-1 will be energized and it will be de-energized when the heating output is 0%.
- When heating output is >25% Heat Stage-2 will be energized and it will be de-energized when the heating output is 20%.
- When heating output is >50% Heat Stage-3 will be energized and it will be de-energized when the heating output is 45%.
- When heating output is >75% Heat Stage-4 will be energized and it will be de-energized when the heating output is 70%.

Electric heat staging is subject to the Heating Interstage Timer.

- Constant Air Volume Fan Control:
When the unit enters the Heating Operating state the heating outputs will be controlled based on comparing the Control Temperature to the Active Heating setpoint for the space.
- Duct Static Pressure and Single Zone VAV Fan Control:
When the unit enters the Heating Operating state the heating outputs will be controlled based on comparing the Discharge Air Temperature to the Heating Discharge Air Temperature Setpoint.

SCR Electric Heat / Modulating Hot Water Valve

In units equipped with a SCR electric heat or a modulating chilled water valve, the controller will use PI control to increase or decrease the electric heat output or modulate the valve open and closed.

- Constant Air Volume Fan Control:
When the unit enters the Heating Operating state the heating outputs will be controlled based on comparing the Control Temperature to the Active Heating setpoint for the

space.

- **Duct Static Pressure and Single Zone VAV Fan Control:** When the unit enters the Heating Operating state the heating outputs will be controlled based on comparing the Discharge Air Temperature to the Heating Discharge Air Temperature Setpoint.

D-Kit Compressor

When heating is required, the variable speed compressor will control to the Heating Discharge Air Temperature setpoint.

Preheat Control

Pre heat control is provided to ensure that the entering unit temperature is maintained above a certain value. Preheat is enabled based on Outdoor Air Temperature or Entering Unit Temperature depending on the Preheat Enable Configuration parameter. The supply fan must be running and the unit must be in the heating mode for preheat to be enabled. Preheat control is used when the Electric Heat Type is Preheat or Pre/Supplemental Heat.

When the Preheat Enable Configuration parameter is Outdoor Air Temperature, preheat will be enabled with the outdoor air temperature value drops below the Preheat Low OAT Setpoint value and remain active until the outdoor air temperature rises above the Preheat Low OAT Setpoint value + Preheat Low OAT Differential.

When the Preheat Enable Configuration parameter is Entering Unit Temperature, preheat will be enabled with the entering unit temperature value drops below the Entering Unit Temperature Low Limit value and remain active until the outdoor air temperature rises above the Entering Unit Temperature Low Limit + Preheat Enable Differential.

1-Stage Preheat

For units with 1 stage of electric heat with preheat control, when preheat is required, the electric heat output will be energized and the output will be de-energized when preheat is no longer required.

SCR Preheat

For units with 1 stage of electric heat with preheat control, when preheat is required, the controller will use a PID loop to modulate the SCR electric heater output to maintain the entering unit temperature at the Entering Unit Temperature Preheat Target Setpoint value.

Entering Unit Temperature Low Alarm

For units configured for preheat control, if the heating capacity is maxed out and the entering unit temperature is below the Entering Unit Temperature Low Limit Value for longer than the Entering Unit Temperature Low Alarm Delay, an Entering Unit Temperature Low alarm will be generated.

Special Preheat Startup Sequence

A special start sequence is used for units with SCR preheat. If heat is required within Cold Start Time after power up or an

occupancy change the preheat output will be immediately set to the Cold Start Heating Percent, at which point normal preheat operation will resume.

Supplemental Heat Control

Supplemental heat control is provided on units to provide additional electric heating capacity on units with a non-electric primary heat source (compressor heat pumps). Supplemental electric heat will be used when the primary heat source is at 100% and the heating target is still not being met. When the heat source is at 100% for longer than the discharge air temperature is below the Heating Discharge Air Temperature Setpoint minus the Supplemental Electric Heat Enable Differential for longer than the Supplemental Heat Enable Timer, electric heat output(s) will be used to maintain the heating discharge air temperature setpoint. Electric heat capacity will be 0% before the primary heating source is staged down.

NOTICE

If the electric heat type is Pre/Supplemental Electric heat, the electric heat output(s) can be used for either preheat or supplemental heat. In this case, the control logic will prioritize meeting the preheat demand before the supplemental electric heat demand.

Dehumidification

Mechanical cooling will be used to lower the air temperature enough to wring out moisture and subsequently reheat will be used to raise it back up to achieve the unit discharge air temperature requirements. Reheat types can be Hot Water or Electric Heat. Dehumidification is only available on units with a reheat coil that are equipped with space humidity, discharge air temperature, and (when necessary) leaving coil temperature sensors. When in Dehumidification mode, the unit is not allowed to operate in the Economizer state.

When in the dehumidification mode, if all heating outputs are at maximum and the discharge air temperature is below the Dehumidification Discharge Air Temperature setpoint minus 5°F, the unit will leave the dehumidification state for a minimum of 5 minutes. When in the dehumidification mode, if the control temperature drops below the Occupied Heating setpoint (regardless of heating configuration) the unit will exit the dehumidification state.

Active Dehumidification

When the Dehumidification Type is Active, dehumidification will be available only when there is no call for heating or dehumidification. When dehumidification is required, reheat will control to the Dehumidification discharge Air Temperature setpoint. If there is a call for heating or cooling the unit will exit the dehumidification mode.

Primary Dehumidification

When the Dehumidification Type is Primary, dehumidification will be unavailable when there's a call for heating (dehumidification is available in the cooling or fan only modes). When cooling is required, reheat will be controlled to the Cooling Discharge Air Temperature Setpoint. When cooling nor heating is required,

reheat will be controlled to the Dehumidification Discharge Air Temperature Setpoint.

Passive Dehumidification

Passive dehumidification can be field-enabled on constant air volume units with space humidity sensors, but without reheat coils. Passive dehumidification can be used to reduce the supply fan speed when the unit is cooling and the space humidity is above the dehumidification setpoint.

Dehumidification Initiation

If the Dehumidification Source is Outdoor, dehumidification will be initiated based on the outdoor humidity sensor value. If the Dehumidification Source is Space, dehumidification will be initiated based on the space humidity sensor value. If the Dehumidification Source is Outdoor and Space, dehumidification will be initiated based on an average of the space and outdoor humidity sensor values. The unit may be set up to dehumidify based on relative humidity or dewpoint. Humidity sensors are configured in the Dehumidification Set-Up menu.

- **Relative Humidity:**
When configured for relative humidity, the basis of dehumidification will be determined by the measured relative humidity.
- **Dewpoint:**
When configured for dewpoint, the basis of dehumidification will be determined by the calculated space dewpoint.

Dehumidification Operation

Single Compressor

When dehumidification is active the Compressor-1 output will be energized. Reheat will be controlled as described in the “Reheat Control” section.

Two or Four Compressors

If the Compressor Stages is 2, or the LCT Sensor Type Parameter is single probe, when dehumidification is active the Compressor-1 and Compressor-2 outputs will be staged on and off to maintain the leaving coil temperature setpoint, subject to compressor minimum ON/OFF times and the cooling interstage time. The Compressor-3 and Compressor-4 outputs will not be used. When Compressor Stages is 4 and the LCT Sensor Type Parameter is averaging, when dehumidification is required, the controller will use a PI control to stage the 4 compressor stages to maintain the leaving coil temperature setpoint.

Reheat will be controlled as described in the Reheat Control section.

D-Kit Compressor

For units with D-Kit compressors, the D-Kit is responsible for controlling both the cooling and reheat in dehumidification. When Dehumidification is active, the Dx coil will be controlled to the leaving coil temperature setpoint and the Rh coil will be controlled to the Active Discharge Air Temperature setpoint.

Two-Position ON/OFF Chilled Water Valve

When dehumidification is active the two-position Chilled Water Valve will be open. Reheat will be controlled as described in the “Reheat Control” section.

Modulating Chilled Water Valve

When dehumidification is active the Chilled Water Valve will be modulated open or closed to maintain the leaving coil temperature setpoint. Reheat will be controlled as described in the “Reheat Control” section.

Reheat Control

Single Stage Electric Heat / Two-Position ON/OFF Hot Water Valve

When dehumidification is active the Electric Heat will be on or the Hot Water Valve will be open when the discharge air temperature is below the Dehumidification Discharge Air Temperature Setpoint. The Electric Heat will be de-energized or the Hot Water Valve will be closed when the discharge air temperature is above the Dehumidification Discharge Air Temperature setpoint plus a 5°F differential. Electric heat staging is subject to the Heating Interstage Timer.

Four Stage / SCR / Modulating Valve

When dehumidification is active the Electric Heat/Valve outputs will be used to maintain the Dehumidification Discharge Air Temperature setpoint. Electric Heat staging is subject to the Heating Interstage Timer.

Changeover Valve

Two-Position Chilled Water Valve

In units equipped with a two-position changeover valve, when cooling or heating is required, the changeover valve will be open. The face and bypass damper will be modulated to control the discharge air temperature. When cooling or heating is no longer required, the changeover valve will be closed.

Modulating Changeover Valve

In units equipped with a modulating changeover valve, the controller will use PI control to modulate the valve open and closed.

If the Supply Fan Control is “Constant Speed”, the PI loop will modulate to control to space temperature. If the Supply Fan Control is “Duct Static Pressure” or “Single Zone VAV” the PI loop will modulate to control discharge air temperature to the Cooling/Heating Discharge Air Temperature Setpoint.

Entering Water Temperature Sampling

In units equipped with a modulating changeover valve, when there is a call for heating or cooling, the valve will open (20% if modulating and 100% if two-position) and the Entering Water Sample Timer will begin to count down. The controller will

monitor the entering water temperature to determine if the water is adequate for heating or cooling. If the Entering Water Sample Timer expires and the water temperature is not deemed adequate for the mode of operation, the changeover valve will close and a notification will be provided to the BAS and at the local keypad. If the desired mode of operation is heating, electric heat will be used if it is available. That mode of operation will be locked out for the duration of the Entering Water Retry Timer. The entering water will be deemed adequate if the Entering Water Temperature is greater than the Control Temperature + Entering Water Temperature Differential for heating or if the Entering Water Temperature is less than the Control Temperature - Entering Water Temperature Differential for cooling.

Freezestat

When a unit is equipped with chilled water, hot water, or steam coil, a freeze problem occurs when the optional Freezestat contacts open as a result of detecting an abnormally low water or steam coil temperature.

When the freeze problem occurs, the controller opens the chilled water and heating valves. If the freezestat contacts are closed, the valves return to normal operation.

Outside Air Damper

Outside Air Damper Operation

Units may be configured with a two-position Outdoor Air (OA) Damper or a 0% - 100% OA Economizer. During occupied normal operation, units with a 0% - 100% OA economizer damper control to a minimum outdoor air position, which is a fixed value or optionally determined by space CO₂.

Two-Position Outside Air Damper Operation

Two-position actuators are controlled by an analog output so the OA damper is driven to 100% open position when the OA damper analog output is at its maximum value, and it is driven closed when the OA damper analog output is at its minimum value. Units equipped with a two-position OA damper open when the fan is running and close when it is not running. The damper will be closed when the fan is running in the standby/unoccupied modes. For DOAS applications, the outside air damper should be configured for a 2 position damper.

0% - 100% Outside Air Economizer Operation

A 0% - 100% outdoor air economizer damper is controlled by a modulating analog output. This actuator is driven to its fully open position - nominally 100%, when the OA damper analog output is at its maximum value, and it is closed when the OA damper analog output is at its minimum value. The desired minimum open position between 0 and 100% is normally set by an editable keypad menu item (Min OA Pos). The modulating damper is driven to the closed position when the supply fan is OFF. The modulating damper is driven to the desired minimum

open position when the fan is running and the economizer is not required. Control of the dampers in the Economizer state is described in "Economizer" on page 43.

Closed Operation

In the occupied mode in the Off unit state the OA damper position is always closed. In the unoccupied mode the outdoor air damper is always closed, and in standby mode the damper is closed unless overridden by DCV or Economizer functionality.

Minimum Outside Air Damper Control

When a unit is equipped with a modulating economizer damper the effective minimum OA position is set to a fixed value.

For units equipped with an optional space CO₂ sensor for demand-controlled ventilation (DCV), this minimum position will be automatically adjusted based on comparing the space CO₂ levels to a CO₂ setpoint.

The damper will be at minimum position when the CO₂ level is at or below the MinOACO₂ value, and the damper will be at maximum position when the CO₂ level is at or above the MaxOACO₂ value.

Economizer Control

Economizer Operation

If a unit is equipped with a 0% - 100% Outside Air Economizer, and the outdoor air is suitable for free cooling, the unit attempts to satisfy the cooling load by using the outdoor air before using mechanical cooling. If the control temperature is above the Occupied Cooling Setpoint and the outdoor air is suitable for free cooling, the unit will enter the Econo State.

The transition from the Econo to Econo-Cool operating state occurs when the economizer is unable to satisfy the cooling load and mechanical cooling is available. This will occur if the unit has been in the Econo operating state for longer than the economizer interstage timer.

The economizer changeover method will be preprogrammed based on the sensors shipped with the unit, but may need to be reconfigured in the field to match the desired sequence of operations.

Fixed Drybulb Economizer

All units equipped with a Fixed Drybulb Economizer can be configured to determine if the outdoor air is suitable for free cooling by using a single, fixed outdoor air drybulb setpoint. When the outdoor air temperature is below this setpoint, the economizer is available.

Comparative Drybulb Economizer

Units equipped with a Comparative Drybulb Economizer determine the outdoor air is suitable for free cooling by comparing the control temperature with the outdoor air temperature.

Fixed Outdoor Enthalpy Economizer

Units equipped with a Fixed Outdoor Enthalpy Economizer can be configured to determine if the outdoor air is suitable for free cooling by using a single, fixed outdoor air enthalpy setpoint. When the outdoor air enthalpy is below this setpoint, the economizer is available.

Comparative Energy/Enthalpy Economizer

Units equipped with a Comparative Energy Economizer determines if the outdoor air is suitable for free cooling by comparing the energy enthalpy of the outdoor air and the control enthalpy. If the IA enthalpy is less than the OA enthalpy (minus the differential setpoint) the economizer is available.

OA Temperature Lockout

Units with the optional OA Temperature Lockout enabled, the OA damper will be closed when the OA temperature drops below the OAT Lockout setpoint.

Return Air Damper Operation (Unit Sizes 060-100)

On units with a separate dedicated return air damper actuator (sizes 060-100), return air damper output will vary between the return air damper minimum position value and the return air damper maximum position value directly proportional to the OA damper output as it varies between the OA damper minimum position value and the OA damper maximum position value.

Outdoor Air Damper Output Scaling

The signal sent to the outdoor damper actuator to control its position can be scaled based on the calculated outdoor damper position percentage. If the Outdoor Air Damper Output Scaling parameter is set to linear, the output signal will be directly related to the calculated outdoor air damper position percentage. If the Outdoor Air Damper Output Scaling parameter is set to Squared, the output will be scaled to the calculated percentage (%) by the following equation:

$$\text{Outdoor Air Damper Output} = (\text{Calculated } \%^2)/1000$$

Return Air Damper Output Scaling

The signal sent to the return air damper actuator to control its position can be scaled based on the calculated outdoor damper position percentage. If the Return Air Damper Output Scaling parameter is set to linear, the output signal will be directly related to the calculated outdoor air damper position percentage. If the Return Air Damper Output Scaling parameter is set to Squared, the output will be scaled to the calculated % by the following equation:

$$\text{Outdoor Air Damper Output} = (\text{Calculated } \%^2)/1000$$

Economizer Fault Detection Diagnostics

The economizer fault detection and diagnostics function provides a warning alarm indication of over economizing, under economizing, stuck dampers and excess outdoor air.

OAD End Switch Calibration

On units equipped with economizer fault detection and diagnostic capabilities, the Outdoor Air Damper (OAD) End Switch input requires calibration function that captures the command position, at which the switches open and close at the closed and open ends of the damper modulation range. This function consists of a manually initiated sequence that strikes the dampers fully open, then fully closed, and detects the changes of state of the switch input and records the points where changes occur. The sequence must be initiated while the Unit State is Off and starting with the end switch input in the closed position.

When the Calibrate OAD parameter is set from No to Yes, the following sequence occurs:

1. The damper command is increased 1% every 2 seconds until the OAD End Switch opens.
2. The damper command is then be decreased 1% every 2 seconds until the OAD End Switch input closes. At this point the current command % is captured.
3. The damper command is increased 1% every 2 seconds until the OAD End Switch input opens. At this point the difference between the current command % and the damper end switch closed value is captured.
4. The damper command is increased and held at 100% until the OAD End Switch input closes.
5. The damper command is decreased 1% every 2 seconds until the OAD End Switch input opens.
6. The damper command is increased 1% every 2 seconds until the OAD End Switch input closes. At this point the current command % is captured.
7. The damper command is decreased 1% every 2 seconds until the OAD End Switch input opens. At this point the difference between the damper open end switch value and the current command % value is captured.
8. The damper command is decreased and held at 0% until the OAD End Switch input closes at which point the values captured in Step 2, Step 3, Step 6, Step 7 are written to the damper end switch open (posSwOpen%), Minimum switch differential (MinSwDiff), damper end switch closed (PosSwClose%) and maximum switch differential (MaxSwDiff) parameters respectively.

Calibrate OAD= parameter is then be set back to No and normal unit operation resumes.

View Status

Table 17: Main Menu \ View Status

Menu Display Name	Default	Range	Description
Unit State=	-	OFF	See "Unit State" on page 30
		HEAT	
		COOL	
		ECONO	
		ECONO_COOL	
		DEHUMID	
		FAN_ONLY	
		OVERRIDE	
Ctrl Mode =	Off	AUTO	Cntrl Mode is an adjustable item which sets the occupancy mode of the unit. The unit can be Heat Only, Cool Only, Fan Only, Automatic, or Off.
		HEAT	
		COOL	
		FAN_ONLY	
		OFF	
Occ Mode=	Auto	OCCUPIED	Occ Mode is an adjustable item that sets the occupancy mode for manual occupied, standby, and unoccupied operation, or for automatic operation based on a time schedule input, or manual tenant override (bypass) operation.
		UNOCCUPIED	
		BYPASS	
		STANDBY	
		AUTO	
Room Sensor On/Off=	On	ON	Room Sensor On/Off is a status only item that indicates the status of the on/off input from the integrated thermostat.
		OFF	

Unit Status/Settings

Table 18: Main Menu \ View Status \ Unit Status\Settings

Menu Display Name	Default	Range	Description
Unit State=	-	OFF	Unit State is a status only item which indicates the state of unit operation in which the unit is currently operating. The unit can be in any of the operating states shown.
		HEAT	
		COOL	
		ECONO,	
		ECONO_COOL	
		DEHUMID	
		FAN_ONLY	
		OVERRIDE	
Ctrl Mode=	Off	AUTO	Cntrl Mode is an adjustable item which sets the occupancy mode of the unit.
		HEAT	
		COOL	
		FAN_ONLY	
		OFF	

Menu Display Name	Default	Range	Description
Comp Status=	-	UNAVAIL	Comp Status is a status only item which indicates whether or not compressor cooling is currently allowed.
		AVAIL	
Pri EI Heat Avail=	-	UNAVAIL	Pri EI Heat Avail is a status only item which indicates if the primary electric heating is available.
		AVAIL	
Sup EI Heat Avail=	-	UNAVAIL	Sup EI Heat Avail is a status only item which indicates if the supplemental electric heating is available.
		AVAIL	
Electric Heat Avail=	-	UNAVAIL	Electric Heat Avail is a status only item which indicates whether or not electric heating is currently allowed.
		AVAIL	
Econo Status=	-	UNAVAIL	Econo Status is a status only item which indicates whether or not the economizer is currently enabled.
		AVAIL	
CW Valve Pos=	-	0% - 100%	CW Valve Pos is a status only item which indicates the percentage that the modulating chilled water valve is currently open.
CW Valve Pos=	-	INACTIVE	CW Valve Pos is a status only item which indicates the condition of the two position chilled water valve output.
		ACTIVE	
Comp Stg 1 =	-	INACTIVE	Comp Stg 1 is a status only item which indicates the condition of the compressor stage 1 output.
		ACTIVE	
Comp Stg 2 =	-	INACTIVE	Comp Stg 2 is a status only item which indicates the condition of the compressor stage 2 output.
		ACTIVE	
Comp Stg 3 =	-	INACTIVE	Comp Stg 3 is a status only item which indicates the condition of the compressor stage 3 output.
		ACTIVE	
Comp Stg 4 =	-	INACTIVE	Comp Stg 4 is a status only item which indicates the condition of the compressor stage 4 output.
		ACTIVE	
HW Valve Pos=	-	0% - 100%	HW Valve Pos is a status only item which indicates the percentage that the hot water valve is currently open.
SCR Output=	-	0% - 100%	SCR Output is a status only item which indicates the current capacity of the SCR electric heater.
HW Valve Pos=	-	INACTIVE	HW Valve Pos is a status only item which indicates the condition of the two position hot water valve output.
		ACTIVE	

Menu Display Name	Default	Range	Description
Htg Stg 1 =	-	INACTIVE ACTIVE	Htg Stg 1 is a status only item which indicates the condition of the electric heat stage 1 output.
Htg Stg 2 =	-	INACTIVE ACTIVE	Htg Stg 2 is a status only item which indicates the condition of the electric heat stage 2 output.
Htg Stg 3 =	-	INACTIVE ACTIVE	Htg Stg 3 is a status only item which indicates the condition of the electric heat stage 3 output.
Htg Stg 4 =	-	INACTIVE ACTIVE	Htg Stg 4 is a status only item which indicates the condition of the electric heat stage 4 output.
SAF Capacity=	-	0% - 100%	SAF Capacity is a status only item which indicates the current capacity of the supply air fan.
SAF DSP Spt=	-	0% - 100%	SAF DuctSP Spt is a status only item which indicates the supply fan duct static pressure setpoint. The SAF is modulated with a PI_Loop to maintain this setpoint.
EF Capacity=	-	0% - 100%	EF Capacity is a status only item indicated the current capacity of the exhaust fans.
OAD Position=	-	0% - 100%	OAD/Economizer Cap is a status only item which indicates the percentage that the outdoor air damper is currently open.
OA Rel Hum=	-	0% - 100%	OA Rel Hum is a status only item that indicates the current outdoor air relative humidity reading.
Space Rel Hum =	-	0% - 100%	Space Rel Hum is a status only item that indicates the current space relative humidity reading.
Space Dew Point =	-	0°F - 100°F	Space Dew Point is a status only item that indicates the current calculate space dewpoint.

Occupancy Menu

Table 19: Main Menu \ View Status \ Occupancy

Menu Display Name	Default	Range	Description
Occupancy=	-	Occupied Unocc Bypass Standby	Occupancy is a status only item that displays the current occupancy status. Occupancy can be one of four values, Occupied, Unoccupied, Bypass and Standby.

Occ Mode=	AUTO	Occupied	Occ Mode is an adjustable item that sets the occupancy mode for manual occupied, standby, and unoccupied operation, or for automatic operation based on a time schedule input, or manual tenant override (bypass) operation.
		Unocc	
		Bypass	
		Standby	
NetOccManCmd=	NULL	Occupied	NetOccManCmd is network adjustable item that indicates occupancy mode for manual occupied, standby, and unoccupied operation, or manual tenant override (bypass) operation via a network signal.
		Unocc	
		Bypass	
		Standby	
NetCurrState=	NULL	Occupied	NetCurrState is network adjustable item that indicates occupancy mode for scheduled occupied, standby, and unoccupied operation, or manual tenant override (bypass) operation via a network signal.
		Unocc	
		Standby	
		Null	
Scheduled Occ=	NULL	Null	Occupancy is a status only item that displays the current occupancy status of the internally programmed schedule.
		Unocc	
		Occupied	
Tnt OR Tm Spt=	120	0-480 Minutes	Tnt OR Tm Spt is an adjustable item that sets the amount of time the unit will be in the bypass mode when initiated by a tenant override input.
Tnt OR Time=	-	0-480 minutes	Tnt OR Time is a status only item that displays the remaining amount of time the unit will be in the bypass mode.
Tnt Override=	-	INACTIVE	Tnt Override is a status only item that indicates if tenant override is active.
		ACTIVE	

Date/Time/Schedules Menu

Table 20: Main Menu \ View Status \ Date/Time/Schedule

Menu Display Name	Default	Range	Description
Time=	-	0-23:0-59:0-59	Time: is an adjustable item that sets the current time (Hr:Mn:Sec)
Date=	-	1-12/0-31/1970-9999	Date is an adjustable item that sets the current date. (M/D/Y)
UTC Diff=	-60 min	-1560	UTC Diff is an adjustable parameter that can be set to indicate how the load time where the unit is situated differs from the Co-ordinated Universal Time.
DAILY SCHEDULE			
Mon=	HH:MM – HH:MM	HH:MM – 23:59	The Daily Schedule sets the start and stop times for each of the days of the week. One start and one stop time can be set for each day.
Tue=			
Wed=			
Thu=			
Fri=			
Sat=			
Sun=			
Hol=			
HOLIDAY DATES			
Hol 1=	MMMMD-D/**-MMMDD/**	MMMD-D/**-DEC31/99	The Holiday Schedule is used to set the start and stop times for up to 10 different holidays.
Hol 2=			
Hol 3=			
Hol 4=			
Hol 5=			
Hol 6=			
Hol 7=			
Hol 8=			
Hol 9=			
Hol 10=			
ONE EVENT SCHEDULE			
Beg=	MMMDD/** @ HH:MM	MMMD-D/**-DEC31/99 @ HH:MM – 23:59	The One Event Schedule is used to set the start and stop times for one event.
End=			
DAYLIGHT SAVINGS			
DLS Strt Month=	Mar	NA	DLS Strt Mon is an adjustable item that sets the month for daylight savings time to begin.
		Jan-Dec	
DLS Strt Week=	2ndWeek	1st-Week-5thWeek	DLS Strt Week is an adjustable item that sets the week of the month for daylight savings time to begin.

Menu Display Name	Default	Range	Description
DLS End Month=	Nov	NA	DLS End Mon is an adjustable item that sets the month for daylight savings time to end.
		Jan-Dec	
DLS End Week=	1stWeek	1st-Week-5thWeek	DLS End Week is an adjustable item that sets the week of the month for daylight savings time to end.
DLS Enable=	Auto	Off/Auto	DLS Enable is an adjustable item that sets whether or not daylight savings time is enabled.
Schedule Source=	NULL	OneEvent	Schedule Source is a status only item which indicates the input source or function that is responsible for setting the Scheduled Status internal schedule occupancy parameter.
		Holiday	
		Daily	
		NULL	
Schedule Status=	Null	Null	Schedule Status is a status only item that displays the current occupancy status provided by the the internal schedule displayed in Schedule Source.
		Unocc	
		Occ	
One Event Status=	Null	Null	One Event Status is a status only item that displays the current occupancy status provided by the the one event schedule.
		Unocc	
		Occ	
Holiday Status=	Null	Null	Holiday Status is a status only item that displays the current occupancy status provided by the the holiday schedule.
		Unocc	
		Occ	
Daily Status=	Null	Null	Daily Status is a status only item that displays the current occupancy status provided by the the daily schedule.
		Unocc	
		Occ	

Date/Time Menu

Table 21: Main Menu \ View Status \ Date/Time

Menu Display Name	Default	Range
Time=	-	0-23:0-59:0-59
Date=	-	1-12/0-31/1970-9999
UTC Diff=	-60	-
DAYLIGHT SAVINGS		
DLS Strt Month=	Mar	Jan-Dec
DLS Strt Week=	2ndWeek	1stWeek
		2ndWeek
		3rdWeek
		4thWeek
		5thWeek
DLS End Month=	Nov	Jan-Dec
DLS End Week=	1stWeek	1stWeek
		2ndWeek
		3rdWeek
		4thWeek
		5thWeek
DLS Enable=	Auto	Off Auto

SAF Control

The SAF Control Menu displays the fan operation and the relevant current control parameters.

Table 22: Main Menu \ View Status \ SAF Control

Menu Display Name	Default	Range	Description
Supply Fan=	-	DISABLED	Supply Fan is a status only item which indicates the status of the supply air fan.
		ENABLED	
SAF Capacity=	-	0% - 100%	SAF Capacity is a status only item which indicates the current capacity of the supply air fan.
SAF Duct-Press=	-	0.0 in - 5.0 in	SAF DuctSP Spt is an adjustable item which sets the supply fan duct static pressure setpoint. The SAF is modulated with a PI_Loop to maintain this setpoint.
EF Capacity=	-	0% - 100%	EF Capacity is a status only item which indicates the current capacity of the exhaust fans.
Airflow=	-	NO_FLOW	Airflow is a status only item which indicates the output from the optional airflow proving switch.
		FLOW	
Mn El Ht Fn Spd=	-	0% - 100%	Mn El Ht Fn Spd is a status only item which indicates the minimum supply fan speed command based on active electric heat capacity.

Cooling

Table 23: Main Menu \ View Status \ Cooling

Menu Display Name	Default	Range	Description
CW Valve Pos=	-	0% - 100%	CW Valve Pos is a status only item which indicates the percentage that the modulating chilled water valve is currently open.
ChgOvr Valve Pos=	-	0% - 100%	ChgOvr Valve Pos is a status only item which indicates the percentage that the modulating changeover water valve is currently open.
CW Valve Pos=	Off	INACTIVE	CW Valve Pos is a status only item which indicates the condition of the two position chilled water valve output.
		ACTIVE	
ChgOvr Valve Pos=	-	INACTIVE	ChgOvr Valve Pos is a status only item which indicates the condition of the two position changeover valve output.
		ACTIVE	
Comp Status=	-	-	Comp Status is a status only item which indicates whether or not compressor cooling is currently allowed.
Comp Stg 1 =	-	INACTIVE	Comp Stg 1 is a status only item which indicates the condition of the compressor stage 1 output.
		ACTIVE	
Comp Stg 2 =	-	INACTIVE	Comp Stg 2 is a status only item which indicates the condition of the compressor stage 2 output.
		ACTIVE	
Comp Stg 3 =	-	INACTIVE	Comp Stg 3 is a status only item which indicates the condition of the compressor stage 3 output.
		ACTIVE	
Comp Stg 4 =	-	INACTIVE	Comp Stg 4 is a status only item which indicates the condition of the compressor stage 4 output.
		ACTIVE	

Dehumidification

Table 24: Main Menu \ View Status \ Dehumidification

Menu Display Name	Default	Range	Description
Dehum Status=	-	UNAVAIL	Dehum Status is a status only item which indicates whether or not dehumidification is currently allowed.
		PASSIVE_Avail	
		ACTIVE_Avail	
Primary Dehumid=	-	DISABLE	Status only item that indicates if dehumidification is active while in the cooling or heating state.
		ENABLE	
Indoor Rel Hum=	-	0% - 100%	Indoor Rel Hum is a status only item that indicates the current space relative humidity value being used by the controller. This will be the network supplied relative humidity if available or the input from the space relative humidity sensor.
Indoor Dew-point=	-	0°F - 100°F	Indoor Dew Point is a status only item that indicates the current calculate space dewpoint.
LC Temp=	-	-40°F - 212°F	LC Temp is a status only item which displays the current temperature reading from the unit's leaving coil temperature sensor.
Supply Temp=	-	-40°F - 212°F	Supply Temp is a status only item which displays the current temperature reading from the unit's discharge air temperature sensor (DAT).
Fan Speed=	-	0% - 100%	Fan Speed is a status only item which indicates the current capacity of the supply air fan.

Heating

Table 25: Main Menu \ View Status \ Heating

Menu Display Name	Default	Range	Description
HW Valve Pos=	-	0% - 100%	HW Valve Pos is a status only item which indicates the percentage that the hot water valve is currently open.
HW Valve Pos=	-	INACTIVE	HW Valve Pos is a status only item which indicates the condition of the two position hot water valve output.
		ACTIVE	
Htg Stg 1 =	-	INACTIVE	Htg Stg 1 is a status only item which indicates the condition of the electric heat stage 1 output.
		ACTIVE	
Htg Stg 2 =	-	INACTIVE	Htg Stg 2 is a status only item which indicates the condition of the electric heat stage 2 output.
		ACTIVE	
Htg Stg 3 =	-	INACTIVE	Htg Stg 3 is a status only item which indicates the condition of the electric heat stage 3 output.
		ACTIVE	

Menu Display Name	Default	Range	Description
Htg Stg 4 =	-	INACTIVE	Htg Stg 4 is a status only item which indicates the condition of the electric heat stage 4 output.
		ACTIVE	
SCR Output=	-	0% - 100%	SCR Output is a status only item which indicates the current capacity of the SCR electric heater.
All Htg Maxed=	-	INACTIVE	All Htg Maxed is a status only item which indicates if the all heating sources are at full capacity.
		ACTIVE	
Pri Htg Maxed=	-	INACTIVE	Pri Htg Maxed is a status only item which indicates if the primary heating sources are at full capacity.
		ACTIVE	

Economizer

Table 26: Main Menu \ View Status \ Economizer

Menu Display Name	Default	Range	Description
OAD Positon=	-	0% - 100%	OAD Position is a status only item which displays the current OAD position.
Min OA Pos=	-	0% - 100%	Min OA Pos is an adjustable item which indicates the minimum position of the outdoor damper while the fan is running. The actual OAD damper position will vary between this value and the Max OA Pos depending on economizer and DCV requirements
FreeClg-Status=	-	UNAVAIL	Free Clg Status is a status only item that indicates whether airside economizer free cooling is available or unavailable based on a definable ambient temperature range.
		AVAIL	

Temperatures

Table 27: Main Menu \ View Status \ Temperatures

Menu Display Name	Default	Range	Description
Control Temp=	-	-40°F - 212°F	Control Temp is a status only item which indicates the current Control Temperature value.
Disch Air=	-	-40.0°F - 212.0°F	Disch Air is a status only item which displays the current temperature reading from the unit's discharge air temperature sensor (DAT).
Return Air=	-	-40.0°F - 212.0°F	Return Air is a status only item which displays the current temperature reading from the unit's return air temperature sensor (RAT).

Menu Display Name	Default	Range	Description
EffSpaceT=	-	-40.0°F - 212.0°F	EffSpaceT is a status only item which displays the current space temperature value being used by the controller. This will be the network supplied space temperature if available or the input from the integrated thermostat.
RsSpaceT=	-	-40.0°F - 212.0°F INVALID	RsSpaceT= is a status only item which displays the current space temperature value being provided by the integrated thermostat.
Space Temp=	-	-40.0°F - 212.0°F INVALID	Space Temp is a status only item which displays the current temperature reading from a space temperature sensor. Up to 3 sensors can be attached to the unit.
OA Temp=	-	-40.0°F - 212.0°F	OA Temp is a status only item which displays the current temperature value being used by the controller. This will be the network supplied space temperature if available or the input from the outdoor air temperature sensor.
LC Temp=	-	-40.0°F - 212.0°F	LC Temp is a status only item which displays the current leaving coil temperature reading from the unit mounted temperature sensor. This sensor is available on AHU units with dehumidification capability. This sensor is also installed on AHU units equipped with electric heat and is used by the controller to calculate the heat rise across the heat exchanger by comparing it to the discharge air temperature input. The controller uses this information to protect the heat exchanger against overheating.
EWT=	-	-40.0°F - 212.0°F	EWT is a status only item which displays the current entering water temperature value being used by the controller. This will be the network supplied entering water temperature if available or the input from the entering water temperature sensor.
Ent Unit T=		-4.0°F - 140.0°F	Ent Unit T is a status only item which displays the current temperature reading from unit's entering unit temperature sensor (EUT) connected to the D-Kit controller.
Indoor Temp=	-	-40.0°F - 212.0°F	Status only item that indicates the current indoor air temperature, depending on Ctrl Temp Src.

IAQ Status

Table 28: Main Menu \ View Status \ IAQ Status

Menu Display Name	Default	Range	Description
EffSpaceT=	-	-40°F - 212°F	Space Temp is a status only item which displays the current space temperature value being used by the controller. This will be the network supplied space temperature if available or the input from the integrated thermostat.
Indoor Rel Hum=	-	0% - 100%	Indoor Rel Hum is a status only item that indicates the current space relative humidity value being used by the controller. This will be the network supplied relative humidity if available or the input from the space relative humidity sensor.
Indoor Enthalpy=	-	-200 - 200 BTU/#	Indoor Enthalpy is a status only item that indicates the current calculated indoor enthalpy.
Indoor Dwpnt=	-	0°F - 100°F	Indoor Dwpnt is a status only item that indicates the current calculated indoor dewpoint.
Outdoor Rel Hum=	-	0% - 100%	Outdoor Rel Hum is a status only item that indicates the current outdoor relative humidity value being used by the controller. This will be the network supplied relative humidity if available or the input from the outdoor relative humidity sensor.
Outdoor Enthalpy=	-	-200 - 200 BTU/#	Outdoor Enthalpy is a status only item that indicates the current calculated outdoor enthalpy.
CO2 PPM=	-	0-3000 ppm	CO2 PPM is a status only item that indicates the current space CO2 concentration being used by the controller. This will be the network supplied CO2 concentration if available or the input from the space CO2 sensor.
Supply Air=	-	-40°F - 212°F	Supply Air is a status only item which displays the current temperature reading from the unit's discharge air temperature sensor (DAT).
Return Air=	-	-40°F - 212°F	Return Air is a status only item which displays the current temperature reading from an optional return air temperature sensor.

Unit Maintenance

BACnet MSTP Set-Up

Table 29: Main Menu \ Unit Maintenance \ BACnet MSTP Set-Up

Menu Display Name	Default	Range	Description
ApplyChgs=	No	No Yes	ApplyChanges is an adjustable item which will commit any changes made to the BACnet MS/TP parameters.
Name=	-	-	Name is an adjustable item which sets the BACnet "Name" parameter.
Location=	-	-	Location is an adjustable item which sets the BACnet "Location" parameter.
Description=	-	-	Description is an adjustable item which sets the BACnet "Description" parameter.
Dev Instance=	-	0-4194302	Dev Instance is an adjustable item which sets the BACnet device instance.
MSTP Address=	-	0-127	MSTP Address is an adjustable item which sets the BACnet MS/TP MAC address.
Baud Rate=	38400	9600 19200 38400 76800	Baud Rate is an adjustable item which sets the BACnet MS/TP communication baud rate.
Max Master=	127	1-127	Max Master is an adjustable item which sets the BACnet "Max Master" parameter.
Max Info Frm=	10	1-32	Max Info Frm is an adjustable item which sets the BACnet "Max Info Frames" parameter.
Unit Support=	English	SI/English	Unit Support is an adjustable item which sets the units of measure provided via BACnet communications.

Service Menus

Operating Hours Menu

(also available in Unit Maintenance Menu)

The Operating Hours menu contains status items that display the number run hours for various components and operating states.

Table 30: Main Menu \ Service Menus \ Operating Hours

Menu Display Name	Default	Range	Description
Supply Fan=	-	0.0-999999.0h	Supply Fan is an adjustable item which displays the current supply fan operating hours. This value can be manually reset when the component is replaced.
Exh Fan=	-	0.0-999999.0h	Exh Fan is an adjustable item which displays the current exhaust fan operating hours. This value can be manually reset when the component is replaced.
Filter=	0.0h	0.0-999999.0h	Filter is an adjustable item which displays the supply fan operating hours with the current air filter. This value can be manually reset when the component is replaced.
Compressor 1=	0.0h	0.0-999999.0h	Compressor 1 is an adjustable item which displays the current compressor 1 operating hours. This value can be manually reset when the component is replaced.
Compressor 2=	0.0h	0.0-999999.0h	Compressor 2 is an adjustable item which displays the current compressor 2 operating hours. This value can be manually reset when the component is replaced.
Compressor 3=	0.0h	0.0-999999.0h	Compressor 3 is an adjustable item which displays the current compressor 3 operating hours. This value can be manually reset when the component is replaced.
Compressor 4=	0.0h	0.0-999999.0h	Compressor 4 is an adjustable item which displays the current compressor 4 operating hours. This value can be manually reset when the component is replaced.
Compressor 1 Starts=	0	0-999999	Compressor 1 Starts is an adjustable item which displays the number of starts recorded for compressor 1. This value can be manually reset when the component is replaced.
Compressor 2 Starts=	0	0-999999	Compressor 2 Starts is an adjustable item which displays the number of starts recorded for compressor 2. This value can be manually reset when the component is replaced.

Menu Display Name	Default	Range	Description
Compressor 3 Starts=	0	0-999999	Compressor 3 Starts is an adjustable item which displays the number of starts recorded for compressor 3. This value can be manually reset when the component is replaced.
Compressor 4 Starts=	0	0-999999	Compressor 4 Starts is an adjustable item which displays the number of starts recorded for compressor 4. This value can be manually reset when the component is replaced.

Network Input Status

Table 31: Main Menu \ Service Menus \ Network Input Status

Menu Display Name	Default	Range	Description
Net OAT In=	INVALID	-40°F - 212°F	Net OAT In is a status only item which displays the outdoor air temperature value being provided by network communications (if applicable).
		INVALID	
Net SpaceT In=	INVALID	-40°F - 212°F	Net SpaceT In is a status only item which displays the space temperature value being provided by network communications (if applicable).
		INVALID	
Net-CurrState=	NULL	OCCUPIED	NetCurrState is a status only item which displays the occupancy scheduler value being provided by network communications (if applicable).
		UNOCCUPIED	
		STANDBY	
		NULL	
Net CI Ena=	NULL	DISABLED	Net CI Ena is a status only item which displays the cooling enable value being provided by network communications (if applicable).
		ENABLED	
		NULL	
Net Ht Ena=	NULL	DISABLED	Net Ht Ena is a status only item which displays the heating enable value being provided by network communications (if applicable).
		ENABLED	
		NULL	
Net Ec Ena=	NULL	DISABLED	Net Ec Ena is a status only item which displays the economizer enable value being provided by network communications (if applicable).
		ENABLED	
		NULL	
Net Dehum Ena =	NULL	DISABLED	Net Dehum Ena is a status only item which displays the dehumidification enable value being provided by network communications (if applicable).
		ENABLED	
		NULL	

Menu Display Name	Default	Range	Description
Net Space PPM=	INVALID	0-3000 ppm	Net Space PPM is a status only item which displays the space co2 concentration value being provided by network communications (if applicable).
		INVALID	
Net Rel Humid=	INVALID	0% - 100%	Net Rel Humid is a status only item which displays the space relative humidity value being provided by network communications (if applicable).
		INVALID	
Net OA Humid	INVALID	0% - 100%	Net OA Humid is a status only item which displays the outdoor air relative humidity value being provided by network communications (if applicable).
		INVALID	
NetOccManCmd=	NULL	OCCUPIED	NetOccManCmd is a status only item which displays the occupancy override command being provided by network communications (if applicable).
		UNOCCUPIED	
		BYPASS	
		STANDBY	
		NULL	
Net EWT In=	INVALID	-40°F - 212°F	Net EWT In is a status only item which displays the entering water temperature value being provided by network communications (if applicable).
		INVALID	
Net Supply Fan=	INVALID	0% - 100%	Net Supply Fan is a status only item which displays the supply fan operating speed value being provided by network communications (if applicable).
		INVALID	

Modbus Settings

Table 32: Modbus Settings

Menu Display Name	Default	Range	Description
Parity=	None	Even	Status only items that indicate the Modbus communication setting
		Odd	
		None	
StopBits=	2SBits	1SBit	
		2SBits	
Cmd Delay=	10ms	0-60000 ms	
Rstpms Delay=	200ms	0-60000 ms	
Clear D-Kit(s)=	None	None	Status only item that indicates if a D-Kit alarm is being cleared.
		Reset	
VRV Status=	Good	Good	Status only item that indicates if there is a D-Kit communication error.
		Bad	

Modbus Read

Table 33: Modbus \ Modbus Read

Menu Display Name	Default	Range	Description
Entering Temp=	0.0°C	-20.0°C - 60.0°C	Status only item that indicates the Suction Air Temperature sensor connected to the D-Kit which measures the Entering Unit Temperature.
VRV DewPt Tgt=	0.0°C		Status only item that indicates the dewpoint target differential being used by the D-Kit for dehumidification.
VRV DAT Tgt=	0.0°C		Status only item that indicates the discharge air temperature target setpoint being used by the D-Kit.
VRV DAT=	0.0°C	-20.0°C - 60.0°C	Status only item that indicates the discharge air temperature being used by the D-Kit.

Modbus Write

Table 34: Modbus \ Modbus Write

Menu Display Name	Default	Range	Description
DX Coil Req=	OFF	OFF	Status only item that indicates the DX Coil Request value being written to the D-Kit by the Micro-Tech unit controller.
		ON	
DX Op Mode=	COOLING	COOLING	Status only item that indicates the DX Coil Operating Mode value being written to the D-Kit by the MicroTech unit controller.
		HEATING	

Menu Display Name	Default	Range	Description
RH Coil Req=	OFF	OFF ON	Status only item that indicates the RH Coil Request value being written to the D-Kit by the MicroTech unit controller.
Stop/Drive=	STOP	STOP DRIVE	Status only item that indicates the Drive Stop Command value being written to the D-Kit by the MicroTech unit controller.
Fan Status=	OFF	OFF ON	Status only item that indicates the Fan Operating Status value being written to the D-Kit by the MicroTech unit controller.
Dewpt Tgt=	0.0°C		Status only item that indicates the Dewpoint Target Differential value being written to the D-Kit by the MicroTech unit controller.
DAT Tgt=	0.0°C		Status only item that indicates the Discharge Air Temperature Target value being written to the D-Kit by the MicroTech unit controller.
EV Kit DAT=	0.0°C	-20.0°C - 60.0°C	Status only item that indicates the Discharge Air Temperature value being written to the D-Kit by the MicroTech unit controller.

Modbus Comm Status

Table 35: Modbus \ Modbus Read \ Comm Status

Menu Display Name	Default	Range	Description
Overall Comm Status=	OFF	OFF ON	Status only item that indicates the overall Modbus Communication status between the D-Kit and the MicroTech unit controller.
Comm 1 Status=	OFF	OFF ON	Status only item that indicates the Modbus communication status between the individual D-Kits and the MicroTech unit controller.
Comm 2 Status=	OFF	OFF ON	
Comm 3 Status=	OFF	OFF ON	
Comm 4 Status=	OFF	OFF ON	

Modbus Connect Status

Table 36: Modbus \ Modbus Read \ Connect Status

Menu Display Name	Default	Range	Description
Overall DX Conn=	OFF	OFF ON	Status only item that indicates the overall Connection status to the DX control boards.
DX 1 Connection=	OFF	OFF ON	Status only item that indicates the connection status to the DX control boards in the individual D-Kits.
DX 2 Connection=	OFF	OFF ON	
DX 3 Connection=	OFF	OFF ON	
DX 4 Connection=	OFF	OFF ON	
Overall RH Conn=	OFF	OFF ON	Status only item that indicates the overall Connection status to the RH control boards.
RH 1 Connection=	OFF	OFF ON	Status only item that indicates the connection status to the RH control boards in the individual D-Kits.
RH 2 Connection=	OFF	OFF ON	
RH 3 Connection=	OFF	OFF ON	
RH 4 Connection=	OFF	OFF ON	

Modbus DX/RH Status

Table 37: Modbus \ Modbus Read \ DX/RH Status

Menu Display Name	Default	Range	Description
Overall DX/RH Status=	OFF	OFF ON	Status only item that indicates the overall connection status to all the DX/RH control boards.
DX1/RH1 Status=	OFF	OFF ON	Status only item that indicates the overall connection status to the DX/RH control boards in the individual D-Kits.
DX2/RH2 Status=	OFF	OFF ON	
DX3/RH3 Status=	OFF	OFF ON	
DX4/RH4 Status=	OFF	OFF ON	

Modbus Central Mngr Status

Table 38: Modbus \ Modbus Read \ Central Mngr Status

Menu Display Name	Default	Range	Description
Overall Central Mngr=	OFF	OFF	Status only item that indicates the overall In Central Management status for all the D-kits.
		ON	
Central Mngr 1=	OFF	OFF	Status only item that indicates the In Central Management status for the individual D-Kits.
		ON	
Central Mngr 2=	OFF	OFF	
		ON	
Central Mngr 3=	OFF	OFF	
		ON	
Central Mngr 4=	OFF	OFF	
		ON	

Modbus Comp Status

Table 39: Modbus \ Modbus Read \ Comp Status

Menu Display Name	Default	Range	Description
Overall Comp Status=	OFF	OFF	Status only item that indicates the overall compressor operational status for all the D-kits
		ON	
Comp 1 Status=	OFF	OFF	Status only item that indicates the compressor operational status for the individual D-Kits.
		ON	
Comp 2 Status=	OFF	OFF	
		ON	
Comp 3 Status=	OFF	OFF	
		ON	
Comp 4 Status=	OFF	OFF	
		ON	

Modbus Defrost Status

Table 40: Modbus \ Modbus Read \ Defrost Status

Menu Display Name	Default	Range	Description
Overall Def Status=	OFF	OFF	Status only item that indicates the overall Defrost status for all the D-kits.
		ON	
Defrost 1 Status=	OFF	OFF	Status only item that indicates the Defrost status for the individual D-Kits.
		ON	
Defrost 2 Status=	OFF	OFF	
		ON	
Defrost 3 Status=	OFF	OFF	
		ON	
Defrost 4 Status=	OFF	OFF	
		ON	

Modbus Fan Request Status

Table 41: Modbus \ Modbus Read \ Fan Request Status

Menu Display Name	Default	Range	Description
Overall Fan Req Status=	OFF	OFF	Status only item that indicates the overall Fan Operation Request status for all the D-Kits.
		ON	
Fan Req 1 Status=	OFF	OFF	Status only item that indicates the overall Fan Operation Request status for the individual D-Kits.
		ON	
Fan Req 2 Status=	OFF	OFF	
		ON	
Fan Req 3 Status=	OFF	OFF	
		ON	
Fan Req 4 Status=	OFF	OFF	
		ON	

Modbus System Error Status

Table 42: Modbus \ Modbus Read \ System Error Status

Menu Display Name	Default	Range	Description
Overall Sys Error=	OFF	NONE	Status only item that indicates the overall System Error status for all D-Kits.
		WARNING	
		ALARM	
		ERROR	

Menu Display Name	Default	Range	Description
System 1 Err=	OFF	NONE	Status only item that indicates the System Error parameters in the individual D-Kits
		WARNING	
		ALARM	
		ERROR	
System 2 Err=	OFF	NONE	
		WARNING	
		ALARM	
		ERROR	
System 3 Err=	OFF	NONE	
		WARNING	
		ALARM	
		ERROR	
System 4 Err=	OFF	NONE	
		WARNING	
		ALARM	
		ERROR	
Err 1 Code=	0	0 to 255	Status only item that indicates the Error Code parameters in the individual D-Kits.
Err 2 Code=	0	0 to 255	
Err 3 Code=	0	0 to 255	
Err 4 Code=	0	0 to 255	
Err 1 De- tail=	0	0 to 63	Status only item that indicates the Error Code Detail parameters in the individual D-Kits.
Err 2 De- tail=	0	0 to 63	
Err 3 De- tail=	0	0 to 63	
Err 4 De- tail=	0	0 to 63	
VRV Err Code 1=	0x00	0x00 to 0xFF	Status only item that indicates the Hexidecimal Error Code values in the individual D-Kits.
VRV Err Code 2=	0x00	0x00 to 0xFF	
VRV Err Code 3=	0x00	0x00 to 0xFF	
VRV Err Code 4=	0x00	0x00 to 0xFF	

Alarm Lists

Alarms provide the user with information about abnormal conditions that affect unit operation. The cause of the alarm should be investigated and eliminated before the unit or any disabled equipment in it is placed back into service.

Viewing Alarms

The Active Alarms menu displays up to 10 active alarms. Pushing the scroll wheel in, will show details about the alarm, as well as when it occurred. The Alarm Log, shows the same information, but up to 50 of the latest alarms - both active and previous alarms.

Alarms are categorized as Warnings, Problems or Faults.

Faults are conditions that are serious enough to shut down the unit.

Problems are conditions that result in some limitation of unit operation, but the unit is allowed to continue to operate.

Warnings inform the user of conditions that should be addressed, but do not limit operation in any way.

All active alarms as well as the date and time that they were detected are displayed on the Active Alarm menu. These alarms are displayed in order of priority. Higher priority alarms are displayed first. The last 50 alarm “events” detected, as well as the date and times that they were detected, are displayed on the Alarm Log menu. An alarm “event” is either an alarm becoming active, or being cleared. A “+” symbol precedes the active alarm event and a “-” symbol precedes the cleared alarm event. These alarms are displayed in the order that they were detected. The alarm that was detected most recently is displayed first. Multiple occurrences of the same alarm may appear.

Alarm Resets

Alarm resetting has 3 categories:

- **Manual**
Once the alarm has occurred, the controller will remain in the alarm state until the alarm has been cleared through the keypad, the integrated thermostat, BAS communications, or by cycling power to the controller.
- **Automatic**
The alarm will clear once the alarm conditions have been resolved with no action necessary.
- **Intelligent Reset**
The alarm will clear automatically up to two times in a 7-day period once the alarm conditions have been resolved, but will need to be manually cleared on the third occurrence in a 7-day period.

Table 43: Main Menu \ Service Menus \ Active Alarms

Menu Display Name	Default	Range
LogCt:** Clr Log:	No	NO
		CLEAR_FAULTS
		CLEAR_PROBLEMS
		CLEAR_WARNINGS
		CLEAR_ALL

Table 44: Main Menu \ Service Menus \ Alarm Log

Menu Display Name	Default	Range
LogCt:** Clr Log:	No	0-50:
		No
		Yes

MicroTech Unit Controller Inputs/Outputs

The complete set of Inputs and Outputs that are possible on a MicroTech unit controller are listed below. These vary by configuration and may or not be included on any given unit based on the features selected and shipped from the factory.

Table 45: Main Menu \ Service Menus \ I/O Module Status

Menu Display Name	Default	Range	Description
EMA=	-	OK	EMA is a status only item which indicates the state of communications with optional I/O expansion modules.
		NoComm	

Table 46: Main Menu \ Service Menus \ I/O Status

Menu Display Name	Default	Range	Description
Freeze Input=	-	NORMAL	
		FREEZE	
Change Filter Input=	-	OPEN	
		CLOSED	
Emergency Stop Input=	-	RUN	Status only item that indicates the present condition of the indicated input/output.
		STOP	
OAD End Sw Input=	-	OPEN	
		CLOSED	
Blocked Cond Input=	-	DRY	
		WET	
Air Flow Sts Input=	-	NO_FLOW	
		FLOW	
Space Temp=	-	-40°F - 212°F	
		INVALID	
Space Humidity=	-	0%-100%	Status only item that indicates the present condition of the indicated input/output.
Return Air=	-	-40°F - 158°F	
Return Humidity=	-	0% - 100%	
OA Temp=	-	-40°F - 212°F	
OA Humidity=	-	0% - 100%	
CO2 PPM=	-	0-3000 ppm	
Disch Air=	-	-40°F - 212°F	
Entering Water Temp=	-	-40°F - 212°F	
Leaving Coil Temp	-	-40°F - 212°F	
Duct Static Pressure=	-	0.0-5.0"	
Heating Valve BO=	-	OFF	Status only item that indicates the present condition of the indicated input/output.
		ON	
Htg Stg 1 =	-	OFF	
		ON	
Htg Stg 2 =	-	OFF	
		ON	

Menu Display Name	Default	Range	Description
Htg Stg 3 =	-	OFF	Status only item that indicates the present condition of the indicated input/output.
		ON	
Htg Stg 4 =	-	OFF	
		ON	
CW Valve Pos=	-	OFF	
		ON	
Comp Stg 1 =	-	OFF	
		ON	
Comp Stg 2 =	-	OFF	
		ON	
Comp Stg 3 =	-	OFF	
		ON	
Comp Stg 4 =	-	OFF	
		ON	
VAV Box Output=	-	DISABLED	Status only item that indicates the present condition of the indicated input/output.
		ENABLED	
OA Damper Output=	-	0-10VDC	
Ret Damper Output=	-	0-10VDC	
SAF Cap=	-	0-10VDC	
EF Cap=	-	0-10VDC	
Htg Valve=	-	0-10VDC	
SCR=	-	0-10VDC	
Cig Valve=	-	0-10VDC	
Sen Cig Spt=	-	50°F - 95°F	
Sen Htg Spt=	-	50°F - 95°F	
EMA=	-	OK	Status only item that indicates the present condition of the indicated input/output.
		NoComm	

Main Control Board (POL546)

Table 47: Main Control Board Terminal Information

Terminal	Signal	Range	Description
T2-DO1B	24VAC	On/Off	Compressor 1/ Two Position Chilled Water Valve/ Two Position CW-HW Changeover Water Valve
T3-DO2B	24VAC	On/Off	Electric Heat Stage 1/Two Position Hot Water Valve
T3-DO3	24VAC	On/Off	Compressor 2
T3-DO4	24VAC	On/Off	Fan Run Enable
T5-DO6	24VAC	On/Off	VAV Box Enable Signal
T12	RS485		
T13	KNX PL-Link		QMX/POS Communicating sensor with Space Temperature, Setpoint Adjust
T7-X9	10K Type II	-40°F - 212°F (-40°C - 100°C)	Discharge Air Temperature Sensor
T7-X10	10K Type II	-40°F - 212°F (-40°C - 100°C)	Either the Entering Water or Leaving Coil Temperature Sensor
T7-X11	10K Type II	-40°F - 212°F (-40°C - 100°C)	Outdoor Air Temperature Sensor
T8-X1	Discrete BI	Open - Closed	Title 24 Outdoor Air Damper End Switch
T8-X2	0-10VDC	0% - 100% RH (0-10VDC)	Space Humidity Input
T8-X3	0-10VDC	0-5" WC	Duct Static Pressure Sensor
T8-X4	0-10VDC	0% - 100% (0/2-10VDC)	Outdoor Air Humidity Sensor
T9-X5	0-10VDC	0% - 100% (0-10VDC)	Supply Fan Control Output
T9-X6	0-10VDC	0% - 100% (2-10VDC scaled)	Outdoor Air Damper Output
T9-X7	0-10VDC	0% - 100% (0/2-10VDC)	Modulating Chilled Water Valve Output
T9-X8	0-10VDC	0% - 100% (0/2-10VDC)	Modulating Hot Water Valve or SCR Heat Output
T10-DI1	Discrete BI	Run - Stop	Emergency Stop Input
T10-DI2	Discrete BI	Dry - Wet	Condensate Overflow Float Switch
T11-DI3	24VAC BI	No Flow - Flow	Airflow Status Switch
T11-DI4	24VAC BI	Normal - Freeze	Freeze Stat Input

Expansion Module A I/O (POL965)

POL96E module will be used when the unit is equipped with more than on modulating hot gas reheat valve. Otherwise POL965 will be used.

Table 48: Expansion Module A I/O Terminal Information

Terminal	Signal	Range	Description
T1-DO1	24VAC	On/Off	Compressor 3
T1-DO2	24VAC	On/Off	Compressor 4
T1-DO3	24VAC	On/Off	Electric Heat Stage 2
T1-DO4	24VAC	On/Off	Electric Heat Stage 3
T2-DO5	24VAC	On/Off	Electric Heat Stage 4
T2-DO6	24VAC	On/Off	Exhaust Fan Enable
T4-X1	10K Type II	-40°F - 212°F (-40°C - 100°C)	Return Air Temperature Sensor
T4-X2	0-10VDC	0% - 100% RH (0-10VDC)	Return Air Relative Humidity Sensor
T4-X3	0-10VDC	0% - 100% (2-10VDC scaled)	Return Air Damper Output
T4-X4	Discrete BI	Normal - Dirty	Dirty Filter Switch
T5-X5	0-10VDC	0% - 100% (0-10VDC)	Exhaust Fan Control Output
T5-X6	0-10VDC	0% - 100% (0-10VDC)	Space CO2 Sensor

Save / Restore Settings

Save/Restore Menu

The Save/Restore menu can be used to save or restore the user configured parameters as well as reset the controller back to the factory default parameters. Save Params is an adjustable item used to save the current parameters and configuration.

Table 49: Main Menu \ Service Menus \ Save \ Restore Settings

Menu Display Name	Default	Range	Description
Rstr Params=	No	No Yes	Rstr Params is an adjustable item used to restore the current parameters and configuration.
Rstr Factory=	No	No Yes	Rstr Factory is an adjustable item used to restore the factory parameters and configuration.
Save To Card/USB=	No	No Yes NoCard RdOnly	SaveToCard is an adjustable item used to save the current parameters and configuration to an SD card.
Load From Card/USB=	No	No Yes RdOnly	LoadFromCard is an adjustable item used to restore the current parameters and configuration from an SD card.

Advanced Menus

Unit Configuration

 WARNING
Operational settings should only be made with the advisement of a qualified person; changing key configurations away from factory settings may result in damage to equipment or surrounding property. Recommended settings may vary based on application specific requirements.

Unit Configuration String

After the main control board application software is loaded into the MCB, it must be “configured” for the specific control application. This consists of setting the value of 34 configuration variables within the MCB. These variables define things such as the type of cooling, number of compressors, cooling stages, and the type of heat. If all of these items are not set appropriately for the specific unit, the unit will not function properly. The correct settings for these parameters are defined for a given unit by the unit “Software Configuration Code.” The “Software Configuration Code” consists of a 34-character string of numbers and letters.

The table below lists the configuration code variables, including the position within the code, description of the parameter, and the applicable settings for each. The default values are shown in bold font. The unit is configured at the factory however may also be configured in the field by accessing the Unit Configuration menu. Once changes have been made to the Unit Configuration menu, the Apply Changes flag must be changed from no to yes in order for the controller to recognize the changes. Setting the Apply Changes Flag to Yes will automatically reset the controller.

Unit Configuration

Table 50: Main Menu \ Advanced Menu \ Unit Configuration

Menu Display Name	Default	Range	Description
Apply Changes=	NO	NO YES	ApplyChanges is an adjustable item which will commit any changes made to the configuration parameters.
SAF Control=	CONST_SPEED	CONST_SPEED DSP SZ_VAV	SAF Control is an adjustable item which configures supply fan speed control.
HeatCool Valve=	NONE	NONE COOLING HEATING BOTH	HeatCool Valve is an adjustable item which configures heating and cooling valve operation.
2/4 Pipe=	2PIPE	2PIPE 4PIPE	2/4 Pipe is an adjustable item which configures the chilled water and/or hot water coils.

Menu Display Name	Default	Range	Description
EWT=	NOT_INSTALLED	NOT_INSTALLED INSTALLED	EWT is an adjustable item which configures if the controller will expect an entering water temperature sensor input (network or hardwired), required for 2 pipe changeover systems.
Valve Signal=	BINARY-24VAC	MOD2_TO_10VDC MOD0_TO_10VDC BINARY-24VAC	Valve Signal is an adjustable item which configures the chilled water and/or hot water valve control signal.
Cool Valve Dir=	DIRECT	DIRECT REVERSE	Cool Valve Dir is an adjustable item which configures the chilled water valve action.
Heat Valve Dir=	DIRECT	DIRECT REVERSE	Heat Valve Dir is an adjustable item which configures the hot water valve action.
Chng Valve Dir =	DIRECT	DIRECT REVERSE	Chng Valve Dir is an adjustable item which configures the change-over valve action.
EI Heat Stages=	NONE	NONE, 1STG 4STG SCR	EI Heat Stages is an adjustable item which configures the electric heat control.
EI Heat Type=	PRIMARY	PRIMARY PRE_HEAT SUP_HEAT PRE_AND_SUP_HEAT	EI Heat Type is an adjustable item which configures when and how electric heat will be used.
Compressor Stages=	NONE	NONE 1STG 2STG 4STG VRV-D	Compressor Stages is an adjustable item which configures the number of compressor cooling stages.
D-Kit Quantity=	ONE	ONE TWO FOUR	D-Kit Quantity is an adjustable item which configures the number of D-Kit VRV controllers that will be connected
Ctrl Temp Src=	SPACE	SPACE RETURN AVERAGE OUTDOOR	Control Temp Src is an adjustable item that selects the control temperature source from either a space, return air sensor, the average temperature of the space and return, or the outdoor air sensor.

Menu Display Name	Default	Range	Description
Ctrl Humidity Src=	SPACE	SPACE	Ctrl Humidity Src is an adjustable item which configures which humidity value will be used for dehumidification.
		OUTDOOR	
		SPACE_OUTDOOR	
Preheat Temp In=	OAT	OAT	Preheat Source is an adjustable item that selects which temperature value is used to determine if preheat is needed.
		EUT	
LCT Sensor Type=	SingleProbe	SingleProbe	LCT Sensor Type is an adjustable item which configures the type of leaving oil temperature sensor is used for 4 compressor configurations.
		Averaging	
DCV Enable=	DISABLED	DISABLED	DCV Enable is an adjustable item which configures demand controlled ventilation control.
		ENABLED	
CO2 Sensor=	NOT_INSTALLED	NOT_INSTALLED	CO2 Sensor is an adjustable item which configures the the controller will expect a CO2 sensor input (network or hardwired), required for demand controlled ventilation.
		INSTALLED	
Outdoor Damper=	NOT_INSTALLED	NOT_INSTALLED	Outdoor Damper is an adjustable item which configures the outdoor air damper control.
		2POS	
		MOD	
Economizer=	NONE	NONE	Economizer is an adjustable item which configures the strategy that will be used to determine if the outdoor air is suitable for economizing.
		OAT	
		ENTHALPY_OUT	
		TEMP_DIFF	
		ENTHALPY_DIFF	
OAT Sensor=	NOT_INSTALLED	NOT_INSTALLED	OAT Sensor is an adjustable item which configures if the controller will expect an outdoor air temperature sensor input (network or hardwired), required for economizer operation.
		INSTALLED	
Space Hum Sensor=	NOT_INSTALLED	NOT_INSTALLED	Space Hum Sensor is an adjustable item which configures the controller will expect a space humidity sensor input (network or hardwired).
		INSTALLED	
OA Hum Sensor=	NOT_INSTALLED	NOT_INSTALLED	OA Hum Sensor is an adjustable item which configures the controller will expect a outdoor humidity sensor input (network or hardwired).
		INSTALLED	

Menu Display Name	Default	Range	Description
Return Air Damper=	NOT_INSTALLED	NOT_INSTALLED	Return Air Damper is an adjustable item which configures the return air damper control.
		INSTALLED	
Exhaust Fan=	DISABLED	DISABLED	Exhaust Fan is an adjustable item which configures exhaust fan speed control.
		TRACKING	
		CONST_SPEED	
Exhaust Fan Output=	NOT_INSTALLED	NOT_INSTALLED	Exhaust Fan Output is an adjustable item which enables exhaust fan speed control.
		INSTALLED	
Dehumidification=	NONE	NONE	Dehumidification is an adjustable item which configures dehumidification control.
		PASSIVE	
		ACTIVE	
		PRIMARY	
Leaving Coil Sensor=	NOT_INSTALLED	NOT_INSTALLED	Leaving Coil Sensor is an adjustable item which configures the controller will expect a leaving coil temperature sensor input.
		INSTALLED	
Econo FDD=	DISABLED	DISABLED	Econo FDD is an adjustable item which configures economizer fault detection and diagnostics.
		ENABLED	
Damper End Sw=	NOT_INSTALLED	NOT_INSTALLED	Damper End Sw is an adjustable item which configures the controller will expect outdoor air damper end switch input, required for economizer fault detection and diagnostics.
		INSTALLED	
Filter Notification=	NONE	NONE	Filter Notification is an adjustable item which configures dirty filter notification.
		RUNTIME	
		BINARY_INPUT	
		BOTH	
RAT Sensor=	NOT_INSTALLED	NOT_INSTALLED	RAT Sensor is an adjustable item which configures the controller will expect a return air temperature sensor input (network or hardwired).
		INSTALLED	
Air Flow Proving=	Uninstall	Uninstall	Air Flow Proving is an adjustable item which configures whether or not an Air Flow Proving switch is installed
		Install	
Remote Sensor=	Installed	NotInst	Remote Sensor is an adjustable item which configures whether or not a Remote Space Temperature sensor is installed.
		Installed	
Config Index=	-	-	-

Menu Display Name	Default	Range	Description
Config Fault=	0	0 to 35	Config Fault is a status only item that provides detail regarding a configuration alarm
Apply Changes=	NO	NO	ApplyChanges is an adjustable item which will commit any changes made to the configuration parameters.
		YES	

Advanced Timers

⚠ WARNING

Operational settings should only be made with the advisement of a qualified person; changing key configurations away from factory settings may result in damage to equipment or surrounding property. Recommended settings may vary based on application specific requirements.

Table 51: Main Menu \ Advanced Menus \ Advanced Timers

Menu Display Name	Default	Range	Description
Apply Changes=	No	No Yes	Apply Changes is an adjustable item which will commit any changes made to the BACnet MS/TP parameters.
Pwd Time-out=	10 min	3-30 min	Pwd Timeout is an adjustable item that sets the amount of time in minutes that the controller will allow access to applicable menus without re-entering the necessary password. If the keypad display remains idle for this time period the display will revert to the "main menu" requiring a re-entering of the password.
SAF Ctrl Dly=	-	5-120 Seconds	SAF Ctrl Dly is an adjustable item that sets the duration of time that the minimum speed signal is sent to the variable speed supply air fan after the supply fan is started via a modbus or digital output. Control reverts to either duct pressure or speed after the fan has been on for the SAF CtrlDelay (default 30 seconds).
Change Filter Time=	1440 Hours	360-4320 Hours	Change Filter Time is an adjustable item which sets the incremental supply fan run hours that must occur before a dirty filter warning will be indicated when the Filter Chg Strategy is BINARY_INPUT or BOTH.
Filter Runtime=	0.0 h	0-300000 Hours	Filter Runtime is an adjustable item which displays the supply fan operating hours with the current air filter. This value can be manually reset when the component is replaced.

Menu Display Name	Default	Range	Description
Heat Stage Timer=	-	0-999999 seconds	Heat Stage Timer is a status only item which displays the amount of time remaining before the heating stage timer expires.
Ele Heat Stage Timer=	-	0-30 seconds	Ele Heat Stage Timer is a status only item which displays the amount of time remaining before the supply fan electric heat off timer expires.
DSP Dly Timer=	-	0-120 seconds	DSP Dly Timer is a status only item which displays the amount of time remaining after the VAV box output was energized, before duct static pressure control will be allowed.
SAF On Timer=	-	0-999999 seconds	SAF On Timer is a status only item indicating the amount of time the supply air fan has been running.
State Change Timer=	-	0-999999 seconds	State Change Timer is a status only item indicating the value of the state change timer.
Startup Timer=	-	0-999999 seconds	Startup Timer is a status only item indicating the value of the unit startup change timer.
EWT Htg Tmr=	-	0-600 seconds	EWT Htg Tmr is a status only item indicating the value of the entering water temperature sampling timer for heating.
EWT Clg Tmr=	-	0-600 seconds	EWT Clg Tmr is a status only item indicating the value of the entering water temperature sampling timer for cooling.
EWT Htg Retry=	-	0-600 min	EWT Htg Retry is a status only item indicating the value of the entering water temperature retry timer for heating.
EWT Clg Retry=	-	0-600 min	EWT Clg Retry is a status only item indicating the value of the entering water temperature retry timer for cooling.
DSP Alm Tmr=	-	0-360 seconds	DSP Alm Tmr is a status only item indicating the value of the duct static pressure alarm timer.
RS Comm=	-	INACTIVE	RS Comm is a status only item indicating the status of communications with the integrated thermostat.
		ACTIVE	
RS Spc Tmp Tmr=	-	0-420 seconds	RS Comm is a status only item indicating the value of the timer used in establishing communications with the integrated thermostat.
Comp Start Delay Tm=	-	0-420 seconds	Comp Start Delay Time is a status only item indicating the value of the compressor startup delay timer.
Tnt OR Timer=	-	0-480 minutes	Tnt OR Timer is a status only item indicating the value of the tenant override temporary occupancy timer.

Menu Display Name	Default	Range	Description
Comp 1 On Tmr=	-	seconds	Status only item that indicates the Compressor 1 On Timer
Comp 2 On Tmr=	-	seconds	Status only item that indicates the Compressor 2 On Timer
Comp 3 On Tmr=	-	seconds	Status only item that indicates the Compressor 3 On Timer
Comp 4 On Tmr=	-	seconds	Status only item that indicates the Compressor 4 On Timer
Comp 1 Off Tmr=	-	seconds	Status only item that indicates the Compressor 1 Off Timer
Comp 2 Off Tmr=	-	seconds	Status only item that indicates the Compressor 2 Off Timer
Comp 3 Off Tmr=	-	seconds	Status only item that indicates the Compressor 3 Off Timer
Comp 4 Off Tmr=	-	seconds	Status only item that indicates the Compressor 4 Off Timer
Vrv Comp On Tmr=	-	seconds	Status only item that indicates the VRV Compressor On Timer
Vrv Comp Off Tmr=	-	seconds	Status only item that indicates the VRV Compressor Off Timer

SAF Set-Up

SAF DSP Control

Table 52: Main Menu \ Advanced Menu \ SAF Set-Up \ DSP Control

Menu Display Name	Default	Range	Description
DSP Period=	5	0-600 seconds	DSP Period is an adjustable item that sets the "sampling time" used in the PI control function to vary the supply fan speed when DSP supply fan control is selected.
DSP Gain=	0.1	0.0-255.0	DSP Gain is an adjustable item that sets the "gain" used in the PI control function to vary the supply fan speed when DSP supply fan control is selected.
DSP PAT=	60 seconds	0-600 seconds	DSP PAT is an adjustable item that sets the "project ahead time" used in the PI control function to vary the supply fan speed when DSP supply fan control is selected.
DSPMax-Chg=	5%	0.0-10.0	DSPMaxChg is an adjustable item that sets the maximum value of increase or decrease of the supply fan speed each period used in the PI control function to vary the supply fan speed when DSP supply fan control is selected.
DSP PI Target=	-	0.0-5.0 IWC	DSP PI Target is a status only item that indicates the target value used calculate the error for DSP control.
DSP PI Input=	-	0.0-5.0 IWC	DSP PI Input is a status only item that indicates the measured value that is compared to the DSP PI Target to calculate the error for DSP control.
DSP PI Output=	-	0% - 100%	DSP PI Output is a status only item that indicates the supply fan speed output for DSP supply fan control.

1 Zone VAV Control

Table 53: Main Menu \ Advanced Menu \ SAF Set-Up \ 1ZnVAV Control

Menu Display Name	Default	Range	Description
1ZnVAV Period=	60sec	0-600 seconds	1ZnVAV Period is an adjustable item that sets the "sampling time" used in the PI control function to vary the supply fan speed when 1ZnVAV supply fan control is selected.

Menu Display Name	Default	Range	Description
1ZnVAV Gain=	2	0.0-255.0	1ZnVAV Gain is an adjustable item that sets the "gain" used in the PI control function to vary the supply fan speed when 1ZnVAV supply fan control is selected.
1ZnVAV PAT=	400sec	0-600 seconds	1ZnVAV PAT is an adjustable item that sets the "project ahead time" used in the PI control function to vary the supply fan speed when 1ZnVAV supply fan control is selected.
1ZnVAV-MaxChg=	10.00%	0.0-10.0	1ZnVAVMaxChg is an adjustable item that sets the maximum value of increase or decrease of the supply fan speed each period used in the PI control function to vary the supply fan speed when 1ZnVAV supply fan control is selected.

EF Set-Up

Table 54: Main Menu \ Advanced Menu \ EF Set-Up

Menu Display Name	Default	Range	Description
EF Damper Setpt=	20%	0% - 100%	EF Damper Setpt is an adjustable item that sets the minimum commanded outdoor air damper position, above which the exhaust fan will be allowed to operate.
EF Const Speed Setpt=	75%	0% - 100%	EF Const Speed Setpt is an adjustable item that sets the exhaust fan operating speed when the EF Ctrl= Const. Speed.

Preheat Set-Up

Table 55: Main Menu \ Advanced Menu \ Preheat Set-Up

Menu Display Name	Default	Range	Description
Preheat Source=	OAT	OAT EUT	Preheat Source is an adjustable item that selects which temperature value is used to determine if preheat is needed.
EUT Sp=	20.0°F	10.0°F - 40.0°F	EUT Sp t is an adjustable item which affects the entering unit temperature target used for staging pre-heat when preheat is required.
PH En Diff Sp=	10.0°F	1.0°F - 20.0°F	PH En Unit Diff is an adjustable item which affects the temperature at which the unit will exit the preheat state for staged preheat applications.
PH Tgt Sp=	16.0°F	0.0°F - 40.0°F	PH Tgt Sp is an adjustable item which affects the entering unit temperature target used for staging pre-heat when preheat is required.

Menu Display Name	Default	Range	Description
PH OAT Diff Sp=	2.0°F	1.0°F - 10.0°F	PH OAT Diff Sp is an adjustable item which affects the temperature at which the unit will exit the preheat state when OAT is the Preheat Source.
PH OAT Tgt Sp=	23.0°F	0.0°F - 40.0°F	PH OAT Tgt Sp is an adjustable item which affects the temperature at which the unit will enter the pre-heat state when OAT is the Preheat Source.

Supheat Set-Up

Table 56: Main Menu \ Advanced Menu \ Supheat Set-Up

Menu Display Name	Default	Range	Description
SUP Heat Source=	None	None 1-STG 4-STG SCR	SUP Heat Source is an adjustable item which configures the electric heat control.
Sup Heat Needed=	NOT_NEEDED	NOT_NEEDED NEEDED	Status only item that indicates if supplemental electric heat is needed or not.
Sup Heat En Time=	5 min	1-20 min	Sup Heat En Time is an adjustable item which affects how long to wait before enabling supplemental electric heat. This timer is for steady state operation after the Sup Heat Dly timer has expired.
Sup Heat En Diff=	2.0°F	1.0°F - 10.0°F	Sup Heat En Time is an adjustable item which affects how long to wait before enabling supplemental electric heat. This timer is for steady state operation after the Sup Heat Dly timer has expired.
SupHtg Wait Done=	FALSE	FALSE TRUE	Status only item that indicates if the controller is witing for one of the timers to expire before using supplemental electric heat.
Sup Heat Dly Tm=	15 min	10-60 min	Sup Heat Dly Tm is an adjustable item which affects how long to allow the primary heat source to operate before enabling supplemental electric heat. This timer is for transitions to allow the primary heat source to satisfy the heating demand.

Changeover Valve Set-up

Table 57: Main Menu \ Advanced Menu \ ChngOvr Vlv Set-Up

Menu Display Name	Default	Range	Description
Clg Period=	20 seconds	1-600 seconds	Clg Period is an adjustable item that sets the "sampling time" used in the PI control function to vary the modulating changeover valve position in cooling.
Clg Gain=	1	0.0-255.0	Clg Gain is an adjustable item that sets the "gain" used in the PI control function to vary the modulating changeover valve position in cooling.
Clg PAT=	40 seconds	0-600 seconds	Clg PAT is an adjustable item that sets the "project ahead time" used in the PI control function to vary the modulating changeover valve position in cooling.
Clg Max Chg=	15.00%	0.0-10.0%	ClgMaxChg is an adjustable item that sets the maximum value of increase or decrease of the modulating changeover valve each period used in the PI control function in cooling.
Htg Period=	60 seconds	1-600 seconds	Htg Period is an adjustable item that sets the "sampling time" used in the PI control function to vary the modulating changeover valve position in heating.
Htg Gain=	1.5	0.0-255.0	Htg Gain is an adjustable item that sets the "gain" used in the PI control function to vary the modulating changeover valve position in heating.
Htg PAT=	90 seconds	0-600 seconds	Htg PAT is an adjustable item that sets the "project ahead time" used in the PI control function to vary the modulating changeover valve position in heating.
Htg Max Chg=	10.00%	0.0-10.0%	HtgMaxChg is an adjustable item that sets the maximum value of increase or decrease of the modulating changeover valve each period used in the PI control function in heating.
CO Valve Direction=	DIRECT	DIRECT REVERSE	CO Valve Direction is an adjustable item that sets the changeover water valve output as direct acting (increasing voltage opens the valve) or reverse acting (decreasing voltage opens the valve).

Menu Display Name	Default	Range	Description
CO Valve Signal=	BINARY-24VAC	MOD2_ TO_ 10VDC	CO Valve Signal is an adjustable item that sets the type of signal used to control the changeover water valve.
		MOD0_ TO_ 10VDC	
		BINARY-24VAC	
EWT Diff=	5°F	0°F - 10°F	EWT Diff is an adjustable item that sets the entering water temperature differential.
EWT=	-	-40°F - 212°F	EWT is a status only item which displays the current entering water temperature value being used by the controller. This will be the network supplied entering water temperature if available or the input from the entering water temperature sensor.
Htg PI Target=	-	50°F - 95°F	Htg PI Target is a status only item that indicates the target value used calculate the error for modulating changeover valve control in heating.
Htg PI Input=	-	-40°F - 212°F	Htg PI Input is a status only item that indicates the measured value that is compared to the Htg PI Target to calculate the error for modulating changeover valve control in heating.
Htg PI Output=	-	0% - 100%	Htg PI Output is a status only item that indicates the changeover valve output for modulating changeover valve control in heating.
HW Heating Avail=	-	UNAVAIL	HW Heating Avail is a status only item that indicates if hot water heating is available.
		AVAIL	
Clg PI Target=	-	50°F - 95°F	Clg PI Target is a status only item that indicates the target value used calculate the error for modulating changeover valve control in cooling.
Clg PI Input=	-	-40°F - 212°F	Clg PI Input is a status only item that indicates the measured value that is compared to the Clg PI Target to calculate the error for modulating changeover valve control in cooling.
Clg PI Output=	-	0% - 100%	Clg PI Output is a status only item that indicates the changeover valve output for modulating changeover valve control in cooling.
CW Cooling Avail=	-	UNAVAIL	CW Heating Avail is a status only item that indicates if chilled water cooling is available.
		AVAIL	

Menu Display Name	Default	Range	Description
EWT Heating Status=	IDLE	IDLE	EWT Heating Status is a status only item that indicates that status of the entering water temperature sampling for heating mode.
		TESTING	
		GOOD	
		WAITING	
EWT Cooling Status=	IDLE	IDLE	EWT Cooling Status is a status only item that indicates that status of the entering water temperature sampling for cooling mode.
		TESTING	
		GOOD	
		WAITING	
EWT Htg Tmr=	-	0-600 seconds	EWT Htg Tmr is a status only item indicating the value of the entering water temperature sampling timer for heating.
EWT Clg Tmr=	-	0-600 seconds	EWT Clg Tmr is a status only item indicating the value of the entering water temperature sampling timer for cooling.
EWT Htg Retry=	-	0-600 min	EWT Htg Retry is a status only item indicating the value of the entering water temperature retry timer for heating.
EWT Clg Retry=	-	0-600 min	EWT Clg Retry is a status only item indicating the value of the entering water temperature retry timer for cooling.

CW Clg Set-Up

Table 58: Main Menu \ Advanced Menu \ CW Clg Set-Up

Menu Display Name	Default	Range	Description
Clg Period=	20 seconds	1-600 seconds	Clg Period is an adjustable item that sets the "sampling time" used in the PI control function to vary the modulating chilled water valve position.
Clg Gain=	1	0.0-255.0	Clg Gain is an adjustable item that sets the "gain" used in the PI control function to vary the modulating chilled water valve position.
Clg PAT=	40 seconds	0-600 seconds	Clg PAT is an adjustable item that sets the "project ahead time" used in the PI control function to vary the modulating chilled water valve position.
Clg Max Chg=	15.00%	0.0%-100.0%	ClgMaxChg is an adjustable item that sets the maximum value of increase or decrease of the modulating chilled water valve each period used in the PI control function.

Menu Display Name	Default	Range	Description
CW Valve Direction=	Direct	Direct	CW Valve Direction is an adjustable item that sets the chilled water valve output as direct acting (increasing voltage opens the valve) or reverse acting (decreasing voltage opens the valve).
		Reverse	
CW Valve Signal=	On-Off24VAC	Mod0-10V	CW Valve Signal is an adjustable item that sets the type of signal used to control the chilled water valve.
		Mod2-10V	
		On-Off24VAC	
CW Cooling Avail=	-	Unavail	CW Cooling Avail is a status only item that indicates if chilled water cooling is available.
		Avail	
Clg PI Target=	-	50°F - 95°F	Clg PI Target is a status only item that indicates the target value used calculate the error for modulating chilled water valve control.
Clg PI Input=	-	-40°F - 212°F	Clg PI Input is a status only item that indicates the measured value that is compared to the Clg PI Target to calculate the error for modulating chilled water valve control.
Clg PI Output=	-	0% - 100%	Clg PI Output is a status only item that indicates the supply fan speed output for modulating chilled water valve control.

HW Htg Set-Up

Table 59: Main Menu \ Advanced Menu \ HW Htg Set-Up

Menu Display Name	Default	Range	Description
Htg Period=	60 seconds	1-600 seconds	Htg Period is an adjustable item that sets the "sampling time" used in the PI control function to vary the modulating hot water valve position.
Htg Gain=	1.5	0.0-255.0	Htg Gain is an adjustable item that sets the "gain" used in the PI control function to vary the modulating hot water valve position.
Htg PAT=	90 seconds	0-600 seconds	Htg PAT is an adjustable item that sets the "project ahead time" used in the PI control function to vary the modulating hot water valve position.
Htg Max Chg=	10.00%	0.0-100.0%	HtgMaxChg is an adjustable item that sets the maximum value of increase or decrease of the modulating hot water valve each period used in the PI control function.

Menu Display Name	Default	Range	Description
HW Valve Direction=	Direct	Direct	HW Valve Direction is an adjustable item that sets the hot water valve output as direct acting (increasing voltage opens the valve) or reverse acting (decreasing voltage opens the valve).
		Reverse	
HW Valve Signal=	On-Off24VAC	Mod0-10V	HW Valve Direction is an adjustable item that sets the type of signal used to control the hot water valve.
		Mod2-10V	
		On-Off24VAC	
HW Heating Avail=	-	Unavail	HW Heating Avail is a status only item that indicates if hot water heating is available.
		Avail	
Htg PI Target=	-	50°F - 95°F	Htg PI Target is a status only item that indicates the target value used calculate the error for modulating hot water valve control.
Htg PI Input=	-	-40°F - 212°F	Htg PI Input is a status only item that indicates the measured value that is compared to the Htg PI Target to calculate the error for modulating hot water valve control.
Htg PI Output=	-	0% - 100%	Htg PI Output is a status only item that indicates the supply fan speed output for modulating hot water valve control.

EI Htg Set-Up

Table 60: Main Menu \ Advanced Menu \ EI Htg Set-Up

Menu Display Name	Default	Range	Description
Htg Period=	10sec	1-600 seconds	Htg Period is an adjustable item that sets the "sampling time" used in the PI control function to vary the electric heat output.
Htg Gain=	1.5	0.0-255.0	Htg Gain is an adjustable item that sets the "gain" used in the PI control function to vary the electric heat output.
Htg PAT=	90 seconds	0-600 seconds	Htg PAT is an adjustable item that sets the "project ahead time" used in the PI control function to vary the electric heat output.
Htg Max Chg=	10	0.0-10.0%	HtgMaxChg is an adjustable item that sets the maximum value of increase or decrease of the electric heat output each period used in the PI control function.
Htg PI Target=	-	50°F - 95°F	Htg PI Target is a status only item that indicates the target value used calculate the error for electric heat output control.

Menu Display Name	Default	Range	Description
Htg PI Input=	-	-40°F - 212°F	Htg PI Input is a status only item that indicates the measured value that is compared to the Htg PI Target to calculate the error for electric heat output control.
Htg PI Output=	-	0% - 100%	Htg PI Output is a status only item that indicates the supply fan speed output for electric heat output control.
Elec Heat Avail=	-	UNAVAIL	Elec Heat Avail is a status only item that indicates if electric heat is available.
		AVAIL	
Desired Htg Stage=	-	0-4	Desired Htg Stage is a status only item that indicates the calculated number of electric heat stages required.
Current Htg Stage=	-	0-4	Current Htg Stage is a status only item that indicates the actual number of electric heat stages energized, limited by availability and stage timers.
EI Heat Cmd=		NONE	Status only item that indicates the type of electric heat being provided
		PRE-HEAT	
		SUP	
		PRIMARY	
		REHEAT	

Cooling Set-Up

Table 61: Main Menu \ Advanced Menu \ Cooling Set-Up

Menu Display Name	Default	Range	Description
Lead Circuit=	Runtime	Runtime	Lead Circuit is an adjustable item that sets how the controller determines the sequence in which compressor outputs are activated and deactivated.
		Comp1	
Compressor Diff=	2°F	1°F - 5°F	Compressor Diff is an adjustable item that sets the stage 2 compressor cooling differential.
Clg Period=	10 seconds	0-600 seconds	Clg Period is an adjustable item that sets the "sampling time" used in the PI control function to vary the compressor stage outputs.
Clg Gain=	1	0.0-255.0	Clg Gain is an adjustable item that sets the "gain" used in the PI control function to vary the compressor stage outputs.
Clg PAT=	100 seconds	0-600 seconds	Clg PAT is an adjustable item that sets the "project ahead time" used in the PI control function to vary the compressor stage outputs.

Menu Display Name	Default	Range	Description
Clg Max Chg=	1.0°F	0.0°F - 10.0°F	ClgMaxChg is an adjustable item that sets the maximum value of increase or decrease of the compressor stage output each period used in the PI control function.
Compressor Avail=	-	UNAVAIL AVAIL	Compressor Avail is a status only item that indicates if compressor cooling is available.
Comp Off Timer=	-	0-999999 seconds	Comp Off Timer is a status only item indicating the value of the compressor minimum off timer.
Comp On Timer=	-	0-999999 seconds	Comp On Timer is a status only item indicating the value of the compressor minimum on timer.
Cooling Stage Timer=	-	0-999999 seconds	Cooling Stage Timer is a status only item indicating the value of the cooling stage timer.
Desired Cooling=	-	0% - 100%	Desired Cooling is a status only item that indicates the calculated percentage of compressor cooling capacity required.
Desired Cooling Stg=	-	0-4	Desired Cooling Stg is a status only item that indicates the calculated compressor cooling stage required.
Current Cooling Stage=	-	0-4	Current Cooling Stage is a status only item that indicates the actual number of compressor stages energized, limited by availability, stage timers, and minimum on/off timers.
Comp Turn On=	-	UNAVAIL AVAIL	Comp Turn On is a status only item that indicates if next sequenced compressor output is available to be energized based on stage and compressor minimum on timers.
Comp Turn Off=	-	UNAVAIL AVAIL	Comp Turn Off is a status only item that indicates if the energized compressor output sequenced to be turned off next is available to be deenergized, based on stage and compressor minimum off timers.
Ctg PI Target=	-	-40°F - 212°F	Clg PI Target is a status only item that indicates the target value used calculate the error for compressor staging control.
Ctg PI Input=	-	-40°F - 212°F	Clg PI Input is a status only item that indicates the measured value that is compared to the Clg PI Target to calculate the error for compressor staging control.
Ctg PI Output=	-	0% - 100%	Clg PI Output is a status only item that indicates the supply fan speed output for compressor staging control.

Heating Set-Up

Table 62: Main Menu \ Advanced Menu \ Heating Set-Up

Menu Display Name	Default	Range	Description
Comp Htg Turn On=		Unavail Avail	Status only item that indicates if compressor heating is available.
Comp Htg Turn Off=		Unavail Avail	Status only item that indicates if compressor heating is available to turn off.
All Htg Maxed=		INACTIVE ACTIVE	Status only item that indicates if the controller application considers the primary heating source at maximum capacity.

Econo Set-Up

Table 63: Main Menu \ Advanced Menu \ Econo Set-Up

Menu Display Name	Default	Range	Description
Econo Strategy=	NONE	NONE OAT ENTHAL-PY_OUT TEMP_DIFF ENTHAL-PY_DIFF	Econo Strategy is an adjustable item which sets the strategy that will be used to determine if the outdoor air is suitable for economizing.
OAD Out Scaling=	LINEAR	LINEAR SQUARED	OAD Out Scaling is an adjustable item which sets how the return air damper output signal is scaled.
OAD Min=	20%	0% - 100%	Min OA Pos is an adjustable item which sets the minimum position of the outdoor damper while the fan is running. The actual OAD damper position will vary between this value and the Max OA Pos depending on economizer and DCV requirements.
OAD Max=	100%	0% - 100%	Max OA Pos is an adjustable item which sets the maximum outdoor damper signal that the controller will send.
RAD Out Scaling=	LINEAR	LINEAR SQUARED	OAD Out Scaling is an adjustable item which sets how the outdoor air damper output signal is scaled.
RAD Min=	20%	0% - 100%	Min RA Pos is an adjustable item which sets the position of the return air damper when the outdoor air damper is at its minimum position.

Menu Display Name	Default	Range	Description
RAD Max=	100%	0% - 100%	Max RA Pos is an adjustable item which sets the position of the return air damper when the outdoor air damper is at its maximum position.
Econo OAT Setpt=	70°F	0°F - 100°F	Econo OAT Setpt is an adjustable item which sets the outdoor drybulb temperature, above which the economizer will not be available.
Outdoor Enth Setpt=	28 BTU/#	5-50BTU/lb	Outdoor Enth Setpt is an adjustable item which sets the Outdoor Enthalpy setpoint used in determining economizer availability.
Temp Diff Setpt=	2°F	1°F - 10°F	Temp Diff Setpt is an adjustable item which sets the control temperature to outdoor air temperature differential used in determining economizer availability.
Enth Diff Setpt=	2 BTU/#	1-10 BTU/lb	Enth Diff Setpt is an adjustable item which sets the control enthalpy to outdoor air enthalpy differential used in determining economizer availability.
OAT Lockout Ena=	DISABLED	DISABLED ENABLED	OAT Lockout Ena is an adjustable item which sets if economizer lockout based on low outdoor air temperature is enabled.
OAT Lockout Setpt=	36°F	25°F - 60°F	OAT Lockout Setpt is an adjustable item which sets the outdoor air temperature at which OAT Lockout will be enabled.
Econo Stg Time=	5 min	5-60 min	Econo Stg Time is an adjustable item which sets the economizer interstage timer.
Outdoor Enthalpy=	-	-200-200 BTU/lb	Outdoor Enthalpy is a status only item that indicates the current calculated outdoor enthalpy.
Indoor Enthalpy=	-	-200-200 BTU/lb	Indoor Enthalpy is a status only item that indicates the current calculated indoor enthalpy.
OAT High Status=	-	INACTIVE ACTIVE	OAT High Status is a status only item that indicates if the current outdoor air temperature is too high for economizing.
OAT Lockout Status=	-	UNLOCK LOCK	OAT Lockout Status is a status only item that indicates if the OAT Lockout functionality is preventing economizing.
OAT Status=	-	NOT_OK OK	OAT Status is a status only item that indicates if the outdoor air temperature is suitable for economizing.
Econo Avail=	-	UNAVAIL AVAIL	Econo Status is a status only item which indicates whether or not the economizer is currently enabled.

Menu Display Name	Default	Range	Description
DCV OA Signal=	-	0% - 100%	DCV OA Signal is a status only item that indicates the OA damper position being commanded as part of DCV control.
Eff Econo Strategy=	NONE	NONE OAT ENTHALPY_OUT TEMP_DIFF ENTHALPY_DIFF	Eff Econo Strategy is an adjustable item which indicates the economizer strategy currently being used to determine if the outdoor air is suitable for economizing. This is based on the Econo Strategy and the reliability of the required sensors.

CO2 Sensor Set-Up

Table 64: Main Menu \ Advanced Menu \ CO2 Set-Up

Menu Display Name	Default	Range	Description
DCV Enable=	DISABLED	DISABLED ENABLED	DCV Enable is an adjustable item which sets if demand controlled ventilation will be enabled.
Min OA CO2 Spt=	500 ppm	0-3000 ppm	Min OA CO2 Spt is an adjustable item which sets the measured CO2 level where the DCV OA Signal will be the minimum OA damper position.
Max OA CO2 Spt=	2000 ppm	0-3000 ppm	Max OA CO2 Spt is an adjustable item which sets the measured CO2 level where the DCV OA Signal will be the maximum OA damper position.
DCV OA Signal=	-	0% - 100%	DCV OA Signal is a status only item that indicates the OA damper position being commanded as part of DCV control.
DCV Status=	No	No Yes	DCV OA Signal is a status only item that indicates if DCV has been disabled because of a CO2 sensor problem.

Dehum Set-Up

Table 65: Main Menu \ Advanced Menu \ Dehum Set-Up

Menu Display Name	Default	Range	Description
Dehum Strategy=	NONE	NONE	Dehum Strategy is an adjustable item which configures the controller to use primary, active, passive, or no dehumidification.
		PASSIVE	
		ACTIVE	
		PRIMARY	
Dehum Type=	DEWPT	REL_HUM	Dehum Type is an adjustable item which configures dehumidification will be enabled based on a space relative humidity setpoint or a space dewpoint setpoint.
		DEWPT	
Dehum Required=	-	NONE	Dehum Required is a status only item which indicates if dehumidification is required.
		NEEDED	
Dehum CW Vlv Cmd=	-	0% - 100%	Dehum CW Vlv Cmd is a status only item that indicates the chilled water valve output being commanded as part of dehumidification control.
Dehum Cmp Clg Cmd=	-	0-50%	Dehum Cmp Clg Cmd is a status only item that indicates the compressor cooling output being commanded as part of dehumidification control.
Dehum HW Vlv Cmd=	-	INACTIVE	Dehum HW Vlv Cmd is a status only item that indicates the status of hot water valve control related to dehumidification.
		ACTIVE	
Dehum EH Cmd=	-	INACTIVE	Dehum EH Cmd is a status only item that indicates the status of electric heat control related to dehumidification.
		ACTIVE	
Dehum Available=	-	UNAVAIL	Dehum Available is a status only item that indicates if dehumidification is available.
		PASSIVE_AVAIL	
		ACTIVE_AVAIL	
Dehum DAT Sp=	70.0°F	45.0°F - 120.0°F	Dehum DAT Sp is an adjustable item which sets the temperature that the DAT should be maintained at when it is in the dehumidification mode of operation.
Dehum Htg DAT Sp=	80.0°F	75.0°F - 120.0°F	Dehum Htg DAT Sp is an adjustable item which sets the temperature that the DAT should be maintained at when it is in the heating mode of operation and dehumidification is required.
Dehum Wait Done=	FALSE	FALSE	Status only item that indicates if dehumidification startup delay timer has expired.
		TRUE	
High DAT Lim Spt=	170°F	90°F - 250°F	High DAT Lim Spt is a adjustable setpoint for the high discharge air temperature limit alarm.

Menu Display Name	Default	Range	Description
Low DAT Lim Spt=	40°F	32°F - 50°F	Low DAT Lim Spt is a adjustable setpoint for the low discharge air temperature limit alarm.
DAT Alm Dly Spt=	35 Seconds	0-300 Seconds	DAT Alm Dly Spt is an adjustable item that is used to set the sensor alarm delay time.
Low AirTmp Alm Dly=	6 Minutes	0-15 Minutes	Low AirTmp Alm Dly is an adjustable item used to set how long the fan must be running before a low discharge air temperature alarm can occur.

Table 66: Alarm Types and Descriptions

Alarm Number	Alarm Display Name	Reset Type	Description
230	Control Model	Auto	A fault alarm that indicates that there is an incompatibility between unit controller hardware and the software application. Contact Daikin Applied to acquire the correct version of software.
225	Freeze Alarm	Manual	When a unit is equipped with chilled water or hot water coil, the Freeze Alarm occurs when the optional freezestat contacts open as a result of detecting an abnormally low water coil temperature. When the Freeze fault occurs, the controller opens the unit will shut down, 2-position chilled water and/or hot water valves will open, and modulating chilled water and/or hot water valves will open to 50%.
220	Emergency Stop	Auto	An Emergency Stop Fault will occur when the Emergency Stop Input in the Alarm (Open) condition.
219	VRV D-Kit Outdoor Unit Fault Alarm	Auto	The VRV outdoor unit has indicated a fault and the unit needs to be shut down.
216	Entering Unit Temp Sensor Fail	Auto	If the unit requires an entering unit temperature sensor (EUT) for control and the input is open or short circuited , the Entering Unit Temp sensor fail occurs. When the Entering Unit Temp sensor fail occurs, the unit is shut down.
215	Control Temp Failure	Manual	If both the space and optional return air temperature sensor are not reliable, a Control Temperature Failure occurs. When the Control Temperature Fault occurs, the unit is shut down. It remains shut down until the Control Temperature Failure is manually cleared through the unit keypad or via a network signal.
213	Discharge Air Temp Low Fault Alarm	Manual	If the discharge air temperature is less than the Low Discharge Temperature Limit (Default = 40°F) for longer than 35 seconds and the supply fan has been on for longer than the LowDAT temperature alarm delay (Default = 6 minutes), the Low Discharge Air Temperature fault occurs. When the Low Discharge Air Temperature fault occurs, the unit is shut down. It remains shut down until the Low Discharge Air Temperature fault is manually cleared through the unit keypad or via a network signal.
212	Discharge Air Temp High Fault Alarm	Manual	If the discharge air temperature is greater than the High Discharge Temperature Limit (Default = 170°F) and the supply fan has been on for longer than the Temperature Alarm Delay (Default = 35 seconds), the High Discharge Air Temperature fault occurs. When the High Discharge Air Temperature fault occurs, the unit is shut down. It remains shut down until the High Discharge Air Temperature fault is manually cleared through the unit keypad or via a network signal.
210	Airflow Alert	Intel	The Airflow Alert occurs when the airflow switch is installed and indicates that there is no airflow when the supply fan has been running for longer than the air flow start delay. When the Airflow Alert occurs, the unit is shut down.
209	Entering Unit Temp Low Fault Alarm	Manual	If preheat is required, all forms of pre heat are maxed out and the entering unit temperature is still below setpoint for longer than the Entering Unit Temperature Low Alarm Delay (default 15 minutes), an entering unit temperature Low Fault Alarm will be generated and the unit will be shut down.
207	VRV D-Kit Communication Fault	Auto	If the MicroTech 4 Unit Controller is unable to communicate with the D-Kit controller, a VRV D-Kit Communication Fault alarm will be generated and the unit will be shut down.
205	Discharge Air Temp sensor Fail	Auto	If the unit requires a discharge air temperature sensor (DAT) for control and the input is open or short circuited , the Discharge Air Temp sensor fail occurs. When the Discharge Air Temp sensor fail occurs, the unit is shut down.
202	VRV D-Kit Rh Connection Fault Alarm	Auto	If the D-Kit detects a communication problem with the reheat EEV controller a D-Kit Rh Connection Fault Alarm will be generated and the unit will be shut down.
201	VRV D-Kit Dx Connection Fault Alarm	Auto	If the D-Kit detects a communication problem with the compressor EEV controller a D-Kit Dx Connection Fault Alarm will be generated and the unit will be shut down.
188	Blocked Condensate	Auto	The Blocked Condensate problem occurs when the optional condensate overflow switch is installed and indicates the presence of condensate for longer than 60 seconds. When the Blocked Condensate problem occurs, mechanical cooling and dehumidification are immediately disabled.
177	SZVAV Space Temp Problem with OAT Control	Auto	If the space air temperature sensor value is either invalid on a Single Zone VAV unit where the Control Temperature Source is outdoor air temperature, a SZVAV Space Temp Problem with OAT Control alarm will be generated and the supply fan speed will not be modulated.
175	Space Temp sensor Fail	Auto	A Space Temp sensor Fail problem will occur if the Control Temperature Source is Space or Average, and the space temperature value is not reliable. When the Space Temp sensor Fail problem occurs, the controller will attempt to temporarily switch the Control Temperature Source to Return Air, if the return air temperature is available, otherwise it will result in a Control Temperature Failure.

Alarm Number	Alarm Display Name	Reset Type	Description
165	Duct Static Pressure Sensor Fail	Auto	The Duct Static Pressure Sensor Fail problem occurs if a unit is configured for duct static pressure supply fan control and the duct static pressure sensor input is open or shorted. When the Duct Static Pressure Sensor Fail problem occurs, the supply fan will be set to minimum speed and an alarm will be indicated at the user interfaces and via BACnet.
160	Entering Water Temp sensor Fail	Auto	The Entering Water Temp sensor Fail problem occurs if a unit requiring an entering water temperature sensor for control and the effective entering water temperature is unreliable. When the Entering Water Temp sensor Fail problem occurs, changeover valve heating and cooling will be disabled, and an alarm will be indicated at the user interfaces and via BACnet.
155	Entering Water Temp Inadequate Fail	Auto	The Entering Water Temp sensor Fail problem occurs on a two pipe chilled water/hot water changeover unit if the controller has been sampling the entering water temperature for longer than the entering water temperature sampling time, and it has not been deemed adequate for the appropriate mode of operation. When the Entering Water Temp sensor Fail problem occurs, changeover valve heating and cooling will be disabled for the duration of the entering water temperature retry time, and an alarm will be indicated at the user interfaces and via BACnet.
150	Outdoor Air Temp sensor Fail	Auto	The Outdoor Air Temp sensor Fail problem occurs if a unit requires an outdoor air temperature sensor for control and the effective outdoor air temperature is unreliable. When the Outdoor Air Temp sensor Fail problem occurs, economizer operation will be disabled, and an alarm will be indicated at the user interfaces and via BACnet.
145	CO2 sensor Fail	Auto	The CO2 sensor Fail problem occurs if a unit has demand controlled ventilation enabled and the effective outdoor air temperature is unreliable. When the CO2 sensor Fail problem occurs, demand controlled ventilation operation will be disabled, and an alarm will be indicated at the user interfaces and via BACnet.
140	Outdoor Air Humidity sensor Fail	Auto	The Outdoor Air Humidity sensor Fail problem occurs if a unit requires an outdoor air humidity sensor for control and the effective outdoor air humidity is unreliable. When the Outdoor Air Humidity sensor Fail problem occurs, the economizer strategy will be temporarily be limited to outdoor air temperature, and an alarm will be indicated at the user interfaces and via BACnet.
135	Dehumidification DAT Low	Intel	The Dehumidification DAT Low problem occurs if a unit is in the dehumidification mode, heating is at maximum and the discharge air temperature is below the dehumidification discharge air temperature setpoint -3F for more than 5 minutes. When the Dehumidification DAT Low problem occurs, dehumidification will be disabled for 5 minutes, and an alarm will be indicated at the user interfaces and via BACnet.
130	Space Humidity Sensor Fail	Auto	The Space Humidity Sensor Fail problem occurs if a unit requires a space air humidity sensor for control and the effective space humidity is unreliable. When the Space Humidity sensor Fail problem occurs, the economizer strategy will be temporarily be limited to outdoor air enthalpy, or outdoor air temperature, and an alarm will be indicated at the user interfaces and via BACnet.
125	Return Air Temp sensor Fail	Auto	A Return Air Temp sensor Fail problem will occur if the Control Temperature Source is Return or Average, and the return air temperature value is not reliable. When the Return Air Temp sensor Fail problem occurs, the controller will attempt to temporarily switch the Control Temperature Source to Space, if the space temperature is available, otherwise it will result in a Control Temperature Failure.
120	Leaving Coil Temp sensor Fail	Auto	The Leaving Coil Temp sensor Fail problem occurs if a unit requires a leaving coil temperature sensor for control and the leaving coil temperature sensor input is open or shorted. When the Leaving Coil Temp sensor Fail problem occurs, the economizer strategy will be temporarily be limited to outdoor air enthalpy, or outdoor air temperature, and an alarm will be indicated at the user interfaces and via BACnet.

Alarm Number	Alarm Display Name	Reset Type	Description
45	Outdoor Air Damper Stuck	Auto	<p>A warning alarm indicating the outdoor air dampers are stuck and not modulating will be generated whenever the damper are stuck open or stuck closed. The dampers are considered stuck open when either of the following abnormal situations occurs:</p> <p>The damper command value is less than the calibrated damper end switch closed value continuously for 180 seconds yet the outside air damper end switch input remains open.</p> <p>The damper end switch input does not change from closed to open with 30 seconds of the damper command value dropping (and remaining) below the calibrated damper end switch open value (less the calibrated maximum switch differential).</p> <p>The dampers are considered stuck closed when either of the following abnormal situations occurs:</p> <p>The damper command value is greater than the calibrated damper end switch open value continuously for 180 seconds yet the outside air damper end switch input remains open.</p> <p>The damper end switch input does not change from closed to open with 30 seconds of the damper command value rising above the calibrated damper end switch closed value (plus the calibrated minimum switch differential).</p> <p>The damper stuck warning will also be generated when the damper end switch operation is unreliable. The end switches are considered unreliable when the end switch input remains closed when the damper command value is between the calibrated end switch closed and open values (plus and minus the calibrated minimum and maximum switch differentials). The alarm will automatically clear when the conditions causing the alarm are no longer present.</p>
40	Excess Outdoor Air	Auto	<p>A warning alarm indicating the unit is delivering excessive outdoor air will be generated whenever the outdoor air dampers are stuck open. The outdoor dampers are considered stuck open when either of the following abnormal situations occurs:</p> <p>The damper command value is less than the calibrated damper end switch closed value continuously for 180 seconds yet the outside air damper end switch input remains open.</p> <p>The damper end switch input does not change from closed to open with 30 seconds of the damper command value dropping (and remaining) below the calibrated damper end switch open value (less the calibrated maximum switch differential).</p> <p>The excess outdoor air warning will also be generated while operating in the Econo or Cooling state when the Econo Status is Enabled and the OAT is greater than the Max OAT Limit setting (default 75F).</p> <p>NOTE: This case is ignored when the economizer enable decision is being controlled by a network input or when the economizer changeover method (EconChgovr) is set for OAT/RAT dry bulb comparison (OAT/RAT). The alarm will automatically clear when the conditions causing the alarm are no longer present.</p> <p>NOTE: The damper end switch open (PosSwOpen%), Minimum switch differential (MinSwDiff), damper end switch closed (PosSwClose%) and maximum switch differential (MaxSwDiff) values are determined during the OAD damper end switch calibration process. The alarm will automatically clear when the conditions causing the alarm are no longer valid.</p>
35	Under Economizing	Auto	<p>A warning alarm indicating the unit is not economizing when it should be will be generated whenever the outdoor air dampers are stuck closed while operating in the Econo or Cooling state. The dampers are considered stuck closed when either of the following abnormal situations occurs:</p> <p>The damper command value is greater than the calibrated damper end switch open value continuously for 180 seconds yet the outside air damper end switch input remains open.</p> <p>The damper end switch input does not change from closed to open with 30 seconds of the damper command value rising above the calibrated damper end switch closed value (plus the calibrated minimum switch differential).</p> <p>The under economizing alarm will also be generated if the Econo Status is not Enabled when the OAT is less than the Min OAT Limit setting (default 70F).</p> <p>NOTE: This case is ignored when the economizer enable decision is being controlled by a network input or when the economizer changeover method (EconChgovr) is set for OAT/RAT dry bulb comparison (OAT/RAT).</p> <p>The under economizing alarm will also be generated when the OAT sensor is unreliable or the RAT sensor is unreliable while the OAT is below the Min OAT Limit setting (default 70F) and the economizer changeover method (EconChgovr) is set for OAT/RAT dry bulb comparison (OAT/RAT). The alarm will automatically clear when the conditions causing the alarm are no longer present.</p> <p>NOTE: The damper end switch open (PosSwOpen%), Minimum switch differential (MinSwDiff), damper end switch closed (PosSwClose%) and maximum switch differential (MaxSwDiff) values are determined during the OAD damper end switch calibration process.</p>

Alarm Number	Alarm Display Name	Reset Type	Description
30	Over Economizing	Auto	<p>A warning alarm indicating the unit is economizing when it should not be will be generated whenever the outdoor air dampers are stuck open while operating in the Econo or Cooling operating state. The dampers are considered stuck open when either of the following abnormal situations occurs:</p> <p>The damper command value is less than the calibrated damper end switch closed value continuously for 180 seconds yet the outside air damper end switch input remains open.</p> <p>The damper end switch input does not change from closed to open with 30 seconds of the damper command value dropping (and remaining) below the calibrated damper end switch open value (less the calibrated maximum switch differential).</p> <p>The over economizing warning will also be generated if the Econo Status is Enabled when the OAT is greater than the Max OAT Limit setting (default 75F).</p> <p>NOTE: This case is ignored when the economizer enable decision is being controlled by a network input or when the economizer changeover method (EconChgovr) is set for OAT/RAT dry bulb comparison (OAT/ RAT). The alarm will automatically clear when the conditions causing the alarm are no longer present.</p> <p>NOTE: The damper end switch open (PosSwOpen%), Minimum switch differential (MinSwDiff), damper end switch closed (PosSwClose%) and maximum switch differential (MaxSwDiff) values are determined during the OAD damper end switch calibration process.</p>
25	Duct Static Pressure Alert	Auto	<p>The Duct Static Pressure Alert warning occurs if a unit is configured for duct static pressure supply fan control and the duct static pressure has been .25in above or below setpoint for longer than the duct static pressure alarm timer. When the Duct Static Pressure Sensor Fail warning occurs, an alarm will be indicated at the user interfaces and via BACnet.</p>
20	Change Filter	Auto	<p>The Change Filter warning occurs based on incremental supply fan run hours, or a digital input depending on the Filter Chg Strategy parameter. When the Change Filter warning occurs, an alarm will be indicated at the user interfaces and via BACnet. The alarm will clear when the switch returns to its normal state, or the Filter operating hours has been reset below the Filter Chg Time.</p>
10	VRV D-Kit Defrost Warning Alarm	Auto	<p>This warning indicates that the VRV outdoor unit has entered a defrost state and heating operation may not meet expectations</p>

IO Readings

Table 67: Main Menu \ Advanced Menu \ IO Readings

Menu Display Name	Default	Range	Description
MCB Universal			
MCB X1=	-	0-9999999	Status only item that indicates the unprocessed data of the indicated input/output.
MCB X2=	-	0-9999999	
MCB X3=	-	0-9999999	
MCB X4=	-	0-9999999	
MCB X5=	-	0-9999999	
MCB X6=	-	0-9999999	
MCB X7=	-	0-9999999	
MCB X8=	-	0-9999999	
MCB X9=	-	0-9999999	
MCB X10=	-	0-9999999	
MCB X11=	-	0-9999999	
EMA Universal			
EMA X1=	-	0-9999999	Status only item that indicates the unprocessed data of the indicated input/output.
EMA X2=	-	0-9999999	
EMA X3=	-	0-9999999	
EMA X4=	-	0-9999999	
EMA X5=	-	0-9999999	
EMA X6=	-	0-9999999	
EMA X7=	-	0-9999999	
EMA X8=	-	0-9999999	
MCB DI			
MCB DI1=	Off	Off	Status only item that indicates the unprocessed data of the indicated input/output.
		On	
MCB DI2=	Off	Off	
		On	
MCB DI3=	Off	Off	
		On	
MCB DI4=	Off	Off	
		On	
MCB DI5=	Off	Off	
		On	
MCB DI6=	Off	Off	
		On	
EMA DI1=	Off	Off	
		On	

Menu Display Name	Default	Range	Description
MCB DO			
MCB DO1=	Off	Off	Status only item that indicates the unprocessed data of the indicated input/output.
		On	
MCB DO2=	Off	Off	
		On	
MCB DO3=	Off	Off	
		On	
MCB DO4=	Off	Off	
		On	
MCB DO5=	Off	Off	
		On	
MCB DO6=	Off	Off	
		On	
MCB DO7=	Off	Off	
		On	
MCB DO8=	Off	Off	
		On	
MCB DO9=	Off	Off	
		On	
MCB DO10=	Off	Off	
		On	
EMA DO			
EMA DO1=	Off	Off	Status only item that indicates the unprocessed data of the indicated input/output.
		On	
EMA DO2=	Off	Off	
		On	
EMA DO3=	Off	Off	
		On	
EMA DO4=	Off	Off	
		On	
EMA DO5=	Off	Off	
		On	
EMA DO6=	Off	Off	
		On	

About This AHU

Table 68: Main Menu \ About This AHU

Menu Display Name	Description
App Version=	Status only indicating information concerning the unit controller application version.
Controller ID=	
Controller PN=	
Device ID=	
Main BSP=	
HMI GIUD=	
OBH GIUD=	

Appendix

Example Wiring Diagrams

NOTE: Wiring diagrams are typical, always defer to the wiring diagram provided with the unit

3-Phase Power, Plenum Fan, On-Off Electric Heat, On/Off Damper, Fused

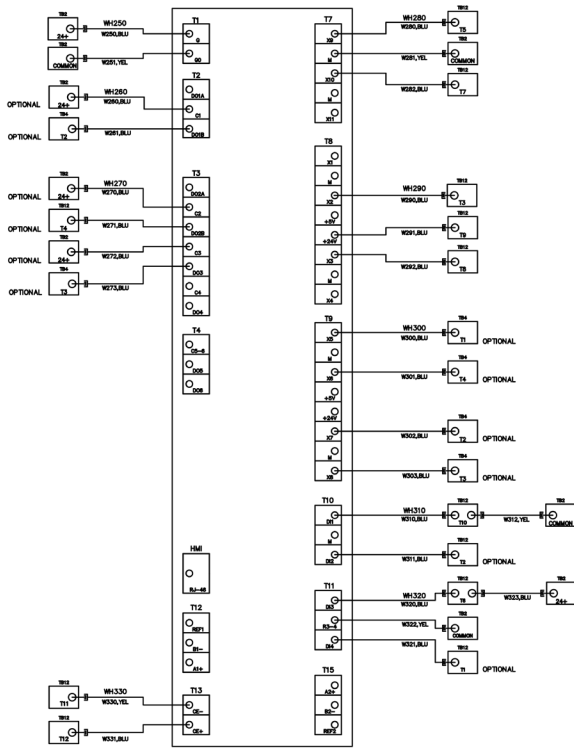

LEGEND: NOTE: DEVICES IN LEGEND MAY OR MAY NOT BE ON UNIT

- ACT MIXING BOX DAMPER ACTUATOR
- COS CONDENSATE OVERFLOW SWITCH
- DAT DISCHARGE AIR TEMPERATURE SENSOR
- D51 DISCONNECT SWITCH
- EVS1 3 SPEED MOTOR CONTROL BOARD - 1 MOTOR
- ENT ENTERING WATER TEMPERATURE SENSOR
- FAN1 FAN MOTOR 1
- FAN2 FAN MOTOR 2
- FRZ2 PRESET/STAT
- FUSE1-3 UNIT FUSES/FUSED DISCONNECT
- FUSE4-6 MOTOR FUSES
- FUSE7-9 BRANCHED CIRCUITRY FUSES
- GND GROUND
- HTR ELECTRIC HEATER
- IMC2 3 SPEED MOTOR CONTROL BOARD - 2 MOTORS
- OAT OUTSIDE AIR TEMPERATURE SENSOR
- OHM AUTOMATIC HIGH TEMPERATURE CUTOFF SWITCH
- OHM1 MANUAL HIGH TEMPERATURE CUTOFF SWITCH
- OHV SC21 HIGH TEMPERATURE CUTOFF SWITCH
- PH1 SINGLE PHASE POWER BLOCK
- PH2 THREE PHASE POWER BLOCK
- RAT RETURN AIR TEMPERATURE SENSOR
- SCR SILICONE CONTROL RECTIFIER
- SSR SOLID STATE RELAY
- TS2 24V POWER TERMINAL BLOCK
- TS2 24V FAN, VALVE, ACTUATOR, & ELECTRIC HAT CONTROL
- TS2 24V SENSOR & SWITCH CONTROL
- WV1 VARIABLE FREQUENCY DRIVE
- WV1.1 2 PRIMARY COIL VALVE ACTUATOR
- W# WIRE HARNESS
- W# WIRE NUT
- WP WIRE PLUG

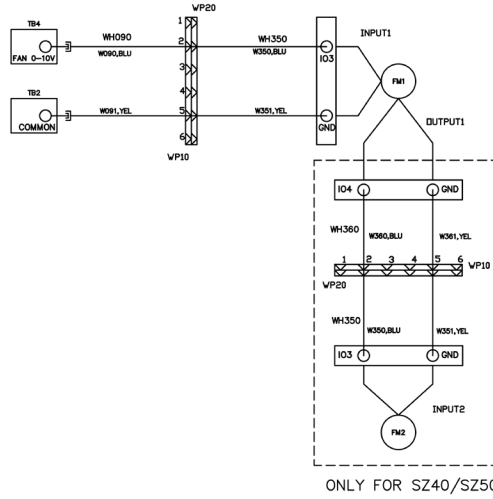

ONLY FOR SZ40/SZ50

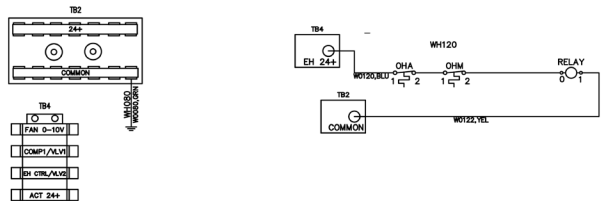

OPTIONAL - SEE BOM

- SPACE HUMIDITY T13
 - COMPRESSOR 2 T14
 - DAT T15
 - AIRFLOW T16
 - EWT / LCT T17
 - DUST STATIC PRESSURE T18
 - DUST STATIC PRESSURE 24+ T19
 - EMERGENCY STOP T10
 - REMOTE SPACE (CE-) T11
 - REMOTE SPACE (CE+) T12
- FIELD MOUNTED

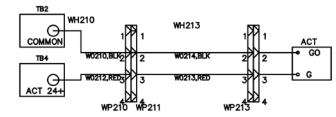

NOTE: Wiring diagrams are typical, always defer to the wiring diagram provided with the unit

MicroTech Unit Controller for Sizes 006-050

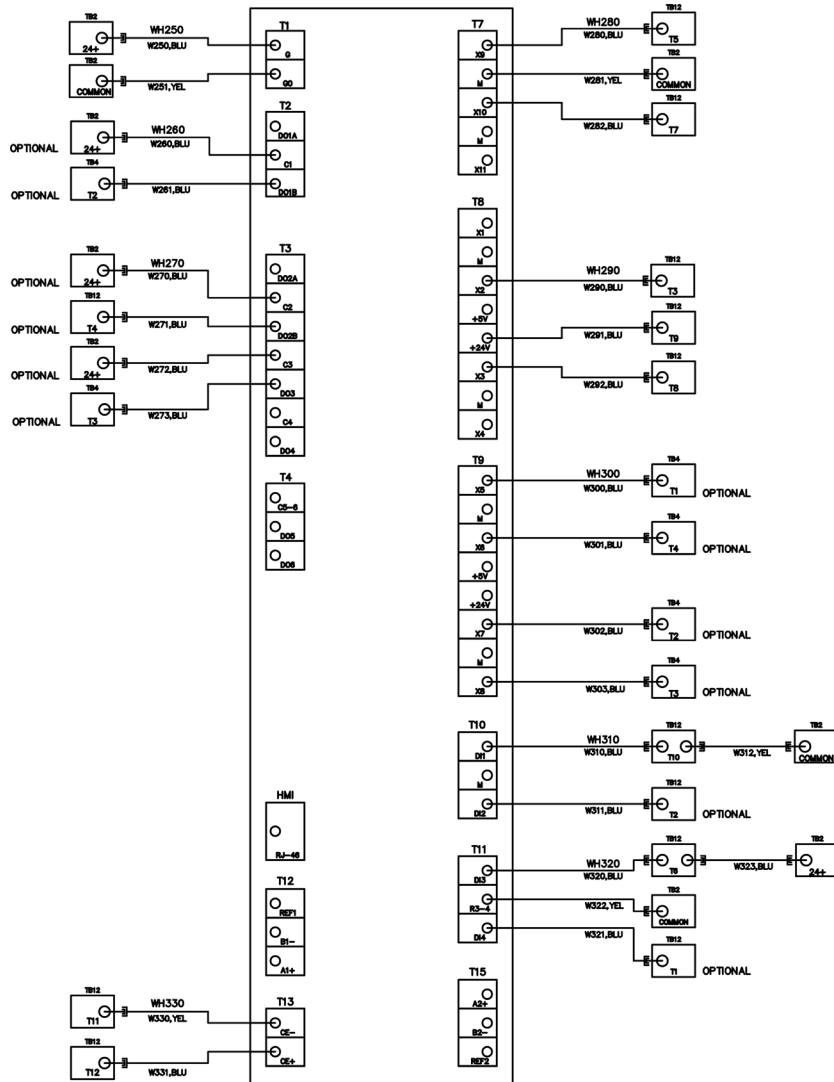

LEGEND: (NOTE DEVICES IN LEGEND MAY OR MAY NOT BE ON UNIT)

- ACT MIXING BOX DAMPER ACTUATOR
- COS CONDENSATE OVERFLOW SWITCH
- DAT DISCHARGE AIR TEMPERATURE SENSOR
- DS1 DISCONNECT SWITCH
- EVO1 3 SPEED MOTOR CONTROL BOARD - 1 MOTOR
- EWT ENTERING WATER TEMPERATURE SENSOR
- FM1 FAN MOTOR 1
- FM2 FAN MOTOR 2
- FRZ FREEZESTAT
- FUSE1-3 UNIT FUSES/FUSED DISCONNECT
- FUSE4-6 MOTOR FUSES
- FUSE7-9 BRANCHED CIRCUITRY FUSES
- GND GROUND
- HTR ELECTRIC HEATER
- MXC2 3 SPEED MOTOR CONTROL BOARD - 2 MOTORS
- OAT OUTSIDE AIR TEMPERATURE SENSOR
- OAH AUTOMATIC HIGH TEMPERATURE CUTOOUT SWITCH
- OHM MANUAL HIGH TEMPERATURE CUTOOUT SWITCH
- OHS SCR HIGH TEMPERATURE CUTOOUT SWITCH
- PB1 SINGLE PHASE POWER BLOCK
- PB1-3PH THREE PHASE POWER BLOCK
- RAT RETURN AIR TEMPERATURE SENSOR
- SCR SILICON CONTROL RECTIFIER
- SSR SOLID STATE RELAY
- TB2 24V POWER TERMINAL BLOCK
- TB4 24V FAN VALVE, ACTUATOR, & ELECTRIC HEAT CONTROL
- TB12 24V SENSOR & SWITCH CONTROL
- VFD VARIABLE FREQUENCY DRIVE
- VLV1, 2 PRIMARY COIL VALVE ACTUATOR
- W WIRE
- WH WIRE HARNESS
- WN WIRE NUT
- WP WIRE PLUG

NOTE: Wiring diagrams are typical, always defer to the wiring diagram provided with the unit

MicroTech Unit Controller for Sizes 060-100

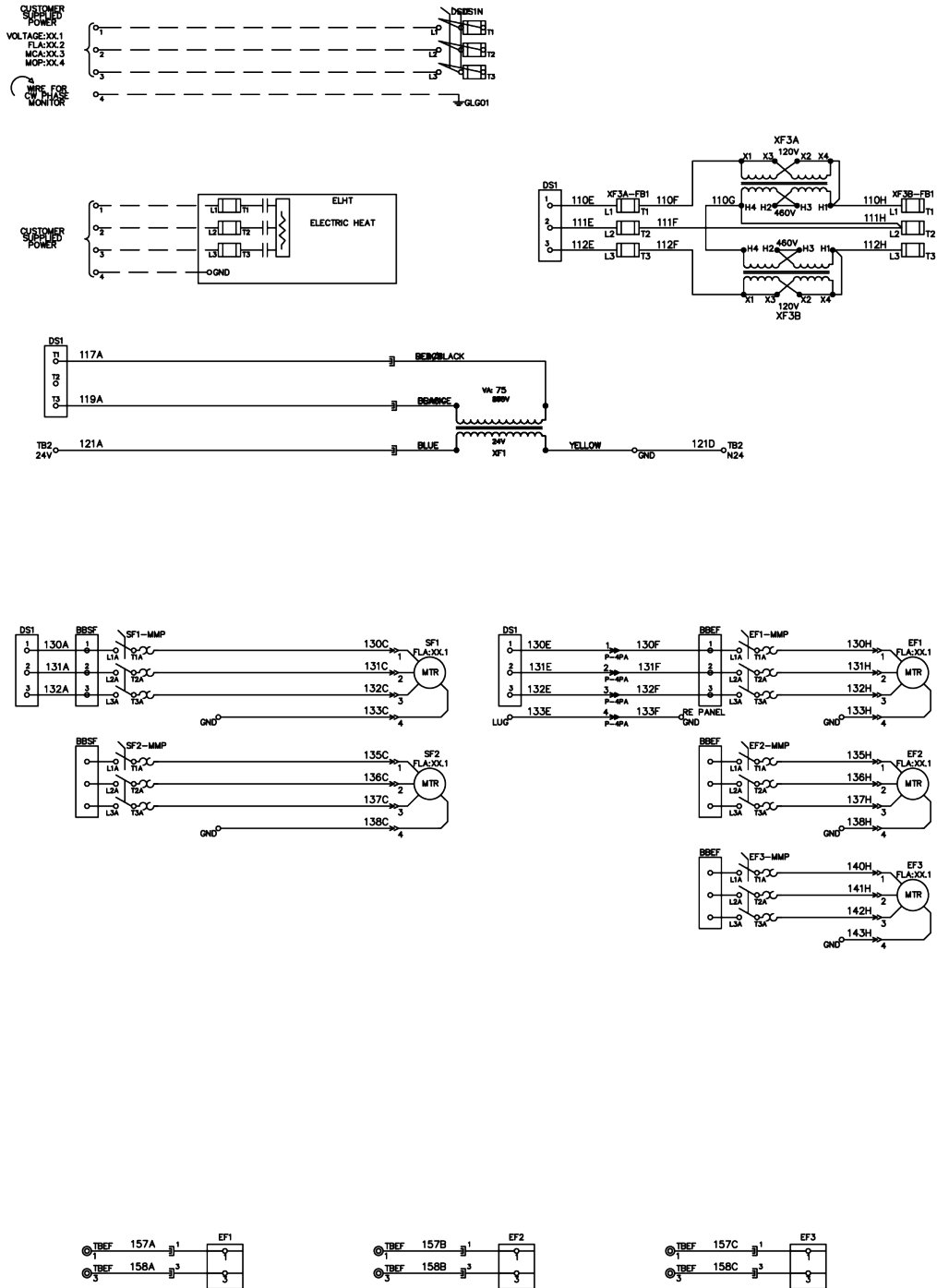

COMPLETE HVAC SYSTEM SOLUTIONS

SELF-CONTAINED | ROOFTOPS | COILS | CONDENSING UNITS
AIR HANDLERS | WATER-COOLED CHILLERS | AIR-COOLED CHILLERS
MODULAR CENTRAL PLANTS | SITELINE BUILDING CONTROLS
UNIT HEATERS | FAN COILS | AIR PURIFIERS | WATER SOURCE HEAT PUMPS
VARIABLE AIR VOLUME UNITS | UNIT VENTILATORS



13600 INDUSTRIAL PARK BLVD. | MINNEAPOLIS, MN 55441
1-800-432-1342 | 763-553-5330

LEARN MORE AT
DAIKINAPPLIED.COM

PART NUMBER: OM1357-3

© 2024 DAIKIN APPLIED | (800) 432.1342 | WWW.DAIKINAPPLIED.COM