

MICROTECH[®] CONTROLLER

MT2300 UNIT CONTROLLER WITH MT2310 I/O EXPANSION BOARD

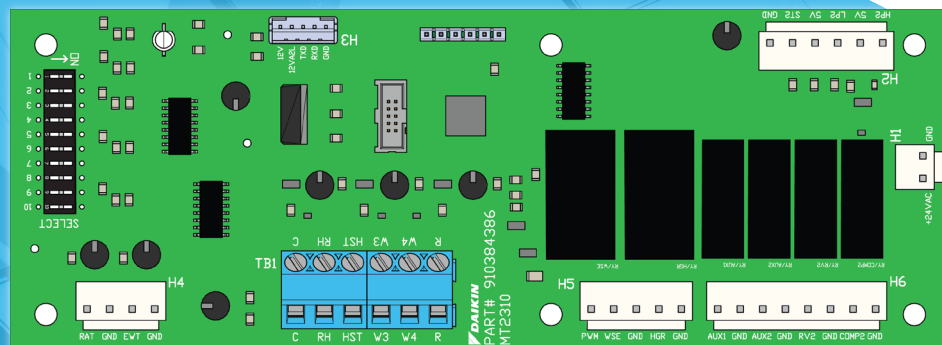
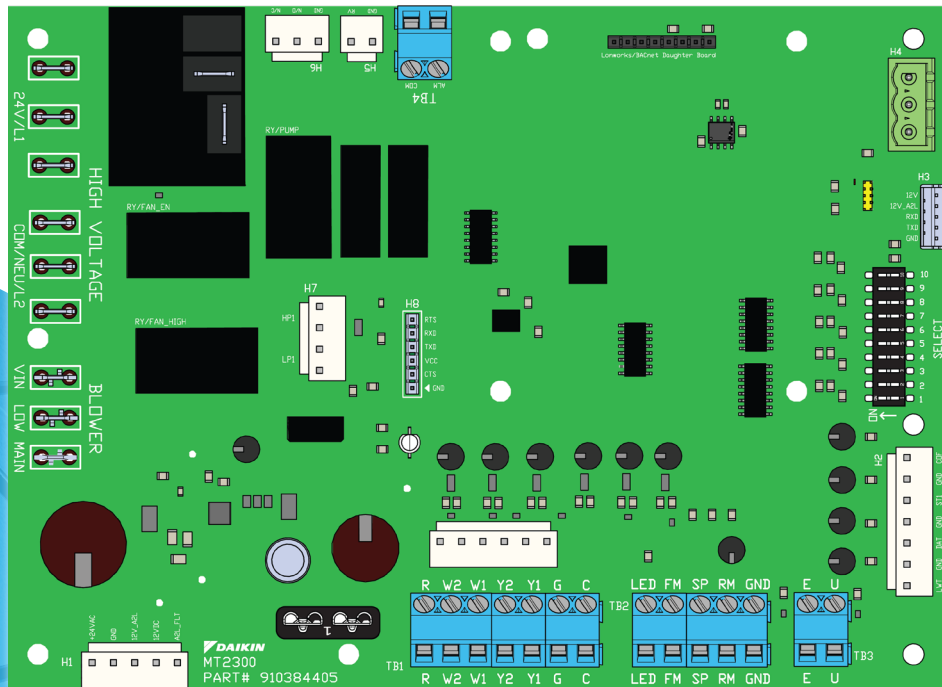

- R-32 REFRIGERANT WATER SOURCE HEAT PUMPS

Safety Information	3	Fault Modes	16
Hazard Identification	3	Faults and Modes	16
Safety Considerations	3	Brownout	17
Introduction	3	High/Low Pressure Faults (HP/LP)	17
Connections and Terminals	4	Low Suction Temperature Fault Heating	18
MT2300 Unit Controller & MT2310 I/O Board		Low Suction Temperature Fault Cooling/Dehumidification	19
Connections	4	Condensate Overflow	19
Unit Controller and Control Modules I/O Descriptions	5	Fan Operation During Most Modes, Faults and	
Replacing Unit Controller	5	Shutdowns	20
Configuration DIP Switches	6	Troubleshooting	21
Functionality	8	MT2300 Unit Controller LED Faults	21
Operating Modes	8	A2L Detection and Mitigation	24
Safety Inputs (HPS, LPS, SLTS, COS)	8	A2L Refrigerant Detection System	24
Control Outputs	9	A2L Leak Mitigation	24
LED Indicators	9	A2L Refrigerant Detection Sensor and Board Service	24
Operation	10	A2L Refrigerant Detection Sensor and Board	
Start-Up	10	Troubleshooting and Diagnostics	24
Fan Speed Selection	10		
Sequence Of Operation	10		
Electric Heat Controls	13		
Unit Status	14		
Remote Shutdown	14		
Thermostat Inputs	14		

©2026 Daikin Applied, Minneapolis, MN. All rights reserved throughout the world. This document contains the most current product information as of this printing. Daikin Applied Americas Inc. has the right to change the information, design, and construction of the product represented within the document without prior notice. For the most up-to-date product information, please go to www.DaikinApplied.com.

™@ MicroTech, SmartSource, and Daikin Applied are trademarks or registered trademarks of Daikin Applied Americas Inc. The following are trademarks or registered trademarks of their respective companies: BACnet from American Society of Heating, Refrigerating and Air-Conditioning Engineers, Inc.; Modbus from Schneider Electric; and Windows from Microsoft Corporation.

Safety Information

Hazard Identification

DANGER

Danger indicates a hazardous situation, which will result in death or serious injury if not avoided.

WARNING

Warning indicates a potentially hazardous situations, which can result in property damage, personal injury, or death if not avoided.

CAUTION

Caution indicates a potentially hazardous situations, which can result in minor injury or equipment damage if not avoided.

NOTICE

Notice indicates practices not related to physical injury.

NOTE: Indicates important details or clarifying statements for information presented in Figures or Tables.

Safety Considerations

This manual provides installation, operation, and maintenance information for a Daikin Applied MicroTech 2300 Unit Controller.

DANGER

LOCKOUT/TAGOUT all power sources prior to service, pressurizing, depressurizing, or powering down the unit. Failure to follow this warning exactly can result in serious injury or death. Disconnect electrical power before servicing the equipment. More than one disconnect may be required to de-energize the unit. Be sure to read and understand the installation, operation, and service instructions within this manual.

WARNING

Electric shock hazard. Improper handling of this equipment can cause personal injury or equipment damage. This equipment must be properly grounded. Connections to and service of the MicroTech control panel must be performed only by personnel that are knowledgeable in the operation of the equipment being controlled.

CAUTION

Static sensitive components. A static discharge while handling electronic circuit boards can cause damage to the components. Discharge any static electrical charge by touching the bare metal inside the control panel before performing any service work. Never unplug any cables, circuit board terminal blocks, or power plugs while power is applied to the panel.

NOTICE

Installation and maintenance are to be performed only by licensed, if required by local codes and regulations, or qualified personnel who are familiar with local codes and regulations and are experienced with this type of equipment.

NOTICE

QUEBEC DISCLOSURE REGARDING AVAILABILITY OF REPLACEMENT PARTS, REPAIR SERVICES AND INFORMATION FOR MAINTENANCE AND REPAIR: Daikin Applied Americas Inc. (Daikin Applied) does not guarantee the availability of (1) replacement parts; (2) repair services; and (3) information necessary to maintain or repair products, within the meaning of section 39.1 of the Consumer Protection Act, CQLR, c P-40.1 and section 79.18 of the Regulation respecting the application of the Consumer Protection Act, CQLR, c P-40.1, r. 3.

AVIS POUR LE QUÉBEC CONCERNANT LA DISPONIBILITÉ DES PIÈCES DE RECHANGE, DES SERVICES DE RÉPARATION ET DES RENSEIGNEMENTS POUR L'ENTRETIEN ET LA RÉPARATION : Daikin Applied Americas Inc. (Daikin Applied) ne garantit pas la disponibilité (1) des pièces de rechange, (2) des services de réparation et (3) des renseignements pour l'entretien et la réparation, au sens de l'article 39.1 de la Loi sur la protection du consommateur, RLRQ c P-40.1 et de l'article 79.18 du Règlement d'application de la Loi sur la protection du consommateur, RLRQ c P-40.1, r. 3.

Introduction

This operation manual covers the MT2300 unit controller and MT2310 I/O expansion board for Daikin Applied Water Source Heat Pumps.

For information on BACnet® communication modules see:

- IM 1363 - MicroTech MT2300 Water Source Heat Pump Unit Controller BACnet MS/TP Network Integration
- ED 19129 - MicroTech MT2300 Water Source Heat Pump Unit Controller BACnet Protocol Information

For information on the MT6210 A2L Mitigation controller see:

- IM 1365 - MT6210 Leak Mitigation Controller for Units Equipped with A2L Refrigerant

Connections and Terminals

MT2300 Unit Controller & MT2310 I/O Board Connections

Figure 1: MT2300 and MT2310 Connections

NOTE: Refer to Table 1 on page 5 for MT2300 controller terminal descriptions and Table 2 on page 5 for MT2310 I/O terminal descriptions.

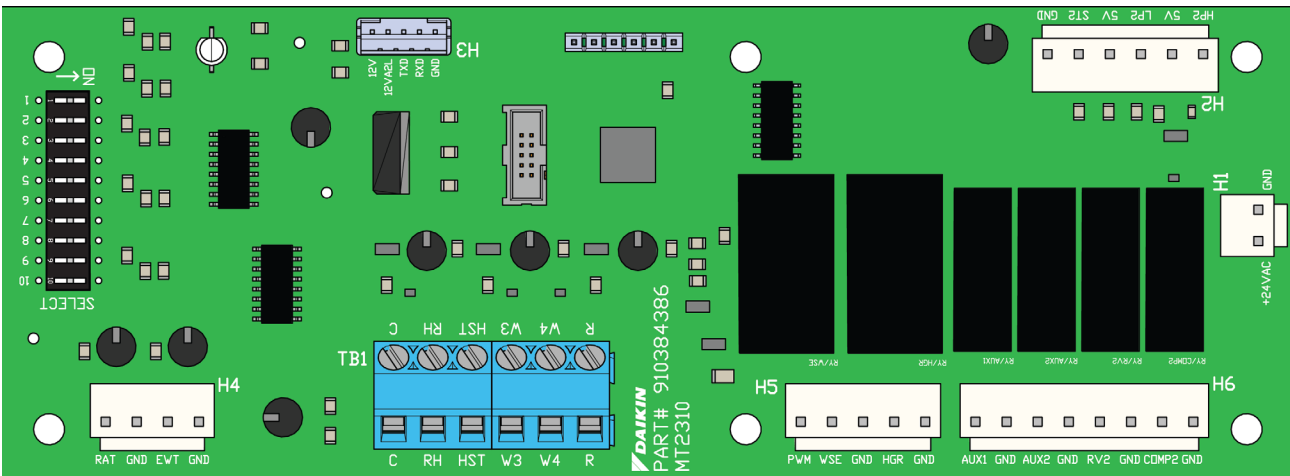
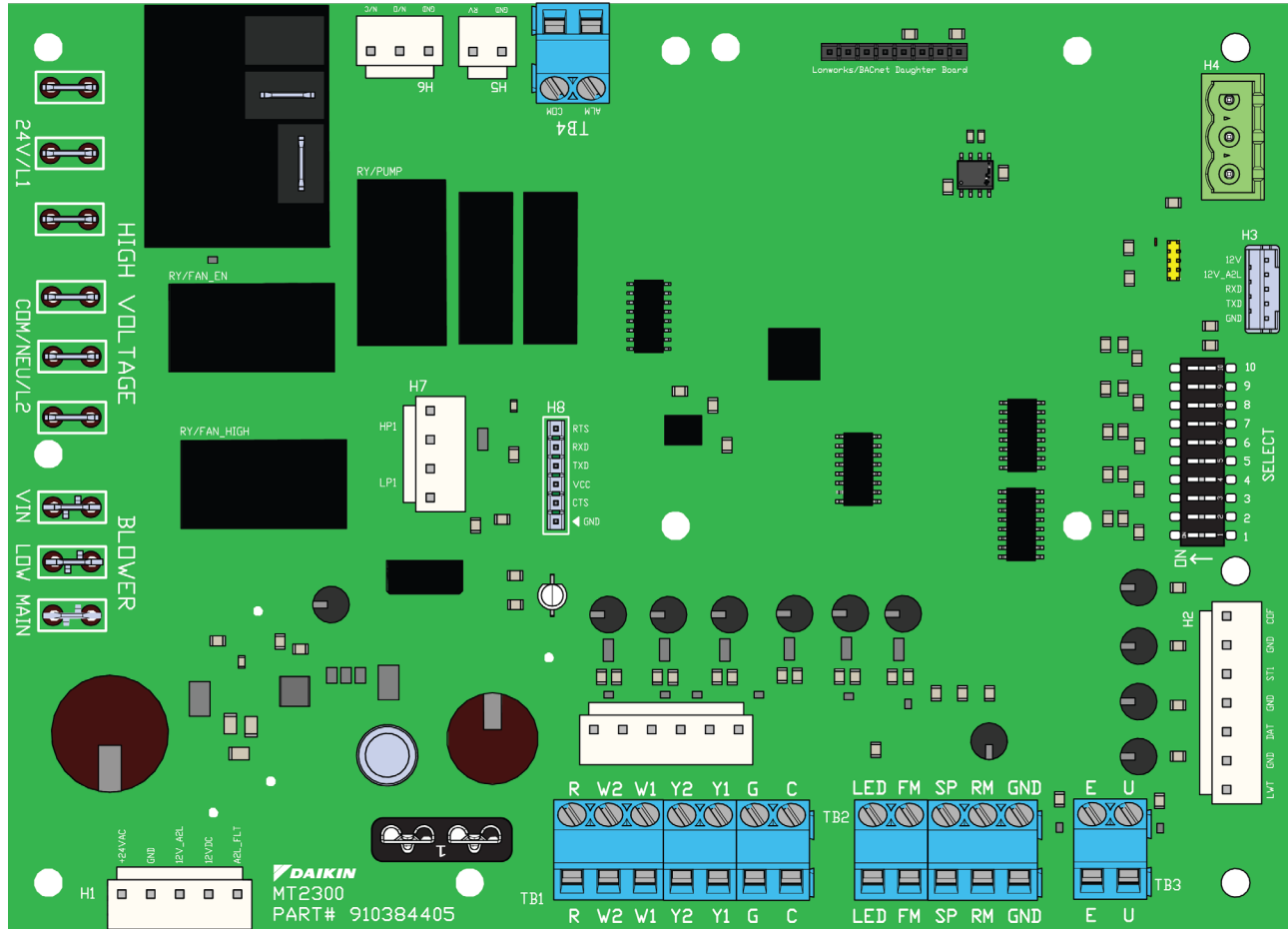

Unit Controller and Control Modules I/O Descriptions

Table 1: MT2300 Unit Controller Connector and Terminal Descriptions

Connector	I/O	Type	Signal	Description
H1-1	+24VAC	Power	VAC	Control Power Voltage
H1-2	GND	Power	Ground	Control Power Common
H1-3	12V_A2L	Input	VDC	A2L Sense Voltage
H1-4	12 VDC	Output	VDC	A2L Mitigation Voltage
H1-5	A2L_ALM	Input	Digital	A2L Fault Alarm
H2-1	LWT	Input	Analog	Leaving Water Temperature
H2-2	GND	REF	Common	
H2-3	DAT	Input	Analog	Discharge Air Temperature
H2-4	GND	REF	Common	
H2-5	ST1	Input	Analog	Comp1 Suction Temperature
H2-6	GND	REF	Common	
H2-7	COF	Input	Analog	Condensate Overflow
H3-1	12V	Output	VDC	Base/Expansion Board Interface
H3-2	12V_A2L	Output	VDC	
H3-3	RXD	COM	UART	
H3-4	TXD	COM	UART	
H3-5	GND	COM	UART	
H4-1	B(+)	COM	N/A	Future Use
H4-2	A(-)	COM	N/A	
H4-3	GND	COM	N/A	
H5-1	GND	REF	Common	Comp1 Reversing Valve
H5-2	RV	Output	24 VAC	
H6-1	GND	REF	Common	Pump Request - Common (Ground) Terminal
H6-2	NO	Output	24 VAC	Pump Request - Normally Open Terminal for Normally Closed Valves
H6-3	NC	Output	24 VAC	Pump Request - Normally Closed Terminal for Normally Open Valves
H7-1,2	LP1	Input	Digital	Comp1 Low Pressure
H7-3,4	HP1	Input	Digital	Comp1 High Pressure
TB1-1	R	Output	24 VAC	Thermostat 24 VAC Power
TB1-2	W2	Input	24 VAC	Thermostat Heat Stage 2
TB1-3	W1	Input	24 VAC	Thermostat Heat Stage 1
TB1-4	Y2	Input	24 VAC	Thermostat Cool Stage 2
TB1-5	Y1	Input	24 VAC	Thermostat Cool Stage 1
TB1-6	G	Input	24 VAC	Thermostat Fan
TB1-7	C	REF	Common	Thermostat Common
TB2-1	LED	Output	5 VDC	Room Sensor LED
TB2-2	FM	Input	Analog	Room Sensor Fan/Mode
TB2-3	SP	Input	Analog	Room Sensor Setpoint Adjust
TB2-4	RM	Input	Analog	Room Sensor Air Temp / Tenant Override
TB2-5	GND	REF	Common	Room Sensor Common
TB3-1	E	Input	Digital	Emergency Shutdown
TB3-2	U	Input	Digital	Unoccupied Sensor
TB4-1,2	ALM	Output	Digital	Alarm Output - Contact Closure
BLOWER	VIN	Input	VAC	Blower Motor Voltage
BLOWER	LOW	Output	VIN	Blower Motor Low Speed
BLOWER	MAIN	Output	VIN	Blower Motor High Speed or ECM
LIVE (Relay)	Comp1	Output	L1/24V	Compressor Stage 1

Connector	I/O	Type	Signal	Description
LIVE x 3	24V/L1	Input	VAC	COMP1 Line1 Control Voltage
LIVE x 3	COM/NEU/L2	Input	VAC	COMP1 Line2 Control Voltage
Daughter Board	BACnet	COM	SPI	BACnet MS/TP Only

Table 2: MT2310 I/O Board Connectors and Terminals

Connector	I/O	Type	Signal	Description
H1-1	GND	Power	Ground	Control Power Common
H1-2	+24VAC	Power	VAC	Control Power Voltage
H2-1	GND	REF	Common	Comp2 Suction Temperature
H2-2	ST2	Input	Analog	
H2-3,4	LP2	Input	Digital	Comp2 Low Pressure
H2-5,6	HP2	Input	Digital	Comp2 High Pressure
H3-1	12V	Input	VDC	Base/Expansion Interface
H3-2	12V_A2L	Input	VDC	
H3-3	TXD	COM	UART	
H3-4	RXD	COM	UART	
H3-5	GND	REF	Common	
H4-1	RAT	Input	Analog	Return Air Temperature
H4-2	GND	REF	Common	
H4-3	EWV	Input	Analog	Entering Water Temperature
H4-4	GND	REF	Common	
H5-1	GND	REF	Common	Hot Gas Reheat Valve
H5-2	HGR	Output	24 VAC	
H5-3	GND	REF	Common	Waterside Economizer Valve
H5-4	WSE	Output	24 VAC	
H5-5	PWM	Output	PWM	Variable Speed Blower Motor
H6-1	GND	REF	Common	Compressor Stage 2
H6-2	COMP2	Output	24 VAC	
H6-3	GND	REF	Common	Comp2 Reversing Valve
H6-4	RV2	Output	24 VAC	
H6-5	GND	REF	Common	Auxiliary Heat 2
H6-6	AUX2	Output	24 VAC	
H6-7	GND	REF	Common	Auxiliary Heat 1 / Hydronic Heat
H6-8	AUX1	Output	24 VAC	
TB1-1	C	REF	Common	Input Common
TB1-2	RH	Input	Analog	Space Relative Humidity
TB1-3	HST	Input	24VAC	Humidistat
TB1-4	W3	Input	24VAC	Thermostat - Stage 3 Heat
TB1-5	W4	Input	24VAC	Thermostat - Stage 4 Heat or Stage 3 Cool
TB1-6	R	Output	24 VAC	Thermostat - 24 VAC Power

Replacing Unit Controller

1. Connect wrist strap to unit.
2. Remove faulty board and place on static protected surface.
3. Remove replacement unit controller from static protection bag.

NOTICE

Hold circuit board by edges to avoid static damage of circuit board components.

4. Holding unit controller in grounded hand, install controller in unit.
5. Insert faulty board in empty static bag for return.

Configuration DIP Switches

WARNING

Proper antifreeze/water solution is required to minimize the potential of fluid freeze-up. Switch SW3 is factory set for water freeze protection with the switch closed. Operation at fluid temperatures below 32°F (0°C) with antifreeze protection requires SW3 to be field configured for the switch on. If unit is employing a fresh water system (no anti-freeze protection), it is extremely important that SW3 switch setting remains in the off position (factory default setting) in order to shut down the unit at the appropriate water temperature to protect your heat pump from freezing. Failure to do so can result in unit damage or property damage and will void unit warranty.

Figure 2: Location of configuration DIP Switches on the MT2300 Unit Controller

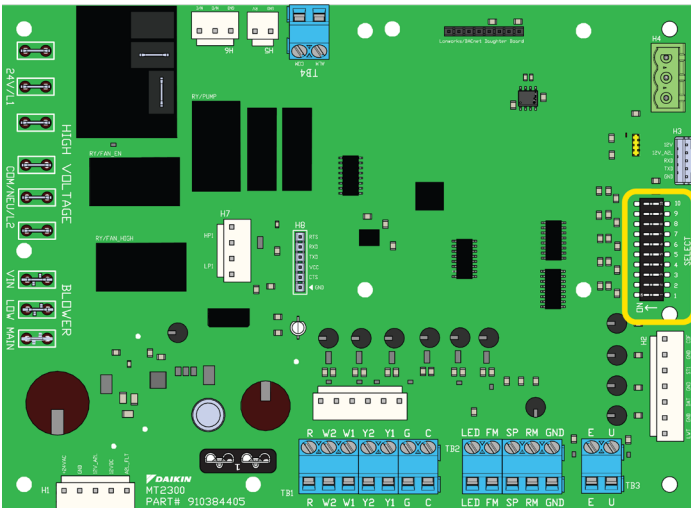

CAUTION

The MT2300 unit controller incorporates static sensitive devices. A static charge from touching the device can damage the electronic components. To help prevent damage during service, use static discharge wrist straps. Static discharge wrist straps are grounded to the heat pump chassis through a 1M ohm resistor.

Table 3: MT2300 Main Board DIP Switch Settings

Switch	Description	Position	Model/Options
SW1	Normal/Test Mode	SW1 = OFF (0)	Normal Operation
		SW1 = ON (1)	Service/Test Mode
SW2	Fan Operation	SW2 = OFF (0)	Continuous Fan Operation (On)
		SW2 = ON (1)	Cycling Fan Operation (Auto)
SW3 ¹	Loop Fluid	SW3 = OFF (0)	Water Loop Fluid
		SW3 = ON (1)	Glycol Loop Fluid
SW4	Freeze Fault Detect (FFD)	SW4 = OFF (0)	Disabled FFD
		SW4 = ON (1)	Enabled FFD with LWT sensor installed
SW5	Room Sensor Setpoint Adjust Range	SW5 = OFF (0)	Short Range -5 to +5 F (-2.78 to +2.78 C)
		SW5 = ON (1)	Long Range 55 to 95 F (12.78 to 35 C)
SW6	Thermostat/Room Sensor Control	SW6 = OFF (0)	Thermostat Control
		SW6 = ON (1)	Room Sensor Control
SW7/ SW8 ²	Single Compressor Heating Source	SW7 = OFF (0)	Allow Compressor in Heating Mode
		SW7 = ON (1)	Disable Compressor in Heating Mode
	Single Compressor IO Expansion Module	SW8 = OFF (0)	I/O Expansion Module Not Required
		SW8 = ON (1)	I/O Expansion Module is Required
	Two Compressor Availability	SW7 = OFF (0) SW8 = OFF (0)	Both Compressors Available (Automatic Compressor Fail Replace)
		SW7 = ON (1) SW8 = OFF (0)	Lead Compressor Available (Lag Compressor is Off-Line)
		SW7 = OFF (0) SW8 = ON (1)	No Compressors Available
SW9	WSHP Base Board Application Select	SW9 = OFF (0)	Single Compressor WSHP Application
		SW9 = ON (1)	Two Compressor Application
SW10	Discrete/Variable Speed Fan Select	SW10 = OFF (0)	Fan Single (Fan Main Output) or Variable (PWM) Speed
		SW10 = ON (1)	Dual Speed Fan (Low & High Discrete Outputs)

¹ See Warning under “Configuration DIP Switches” for DIP switch 3 (SW3) setting information.

² The functionality of SW7 and SW8 depends on the setting of SW9. If SW9 is OFF, SW7 and SW8 will be for Heating Source and I/O Expansion Module functionality. If SW9 is ON, SW7 and SW8 will be for Compressor Availability functionality.

NOTICE

Always disconnect power to the unit prior to making changes to the DIP switch settings on the interface board. The new settings will take effect once power is restored to the unit.

Table 4: MT2310 I/O Expansion Module DIP Switch Settings

Switch	Description	Position	Model/Options
SW1-4	Variable Fan Speed Row Selection	0000 to 1111 Binary	Variable Speed Fan Row Selection (1 to 16), used when "nciVsNetCfgEn" is set to "Disable" the network override.
SW5/ SW6	Secondary Heating Options	SW5 = OFF (0) SW6 = OFF (0)	None
		SW5 = ON (1) SW6 = OFF (0)	Supplemental Electric Heat
		SW5 = OFF (0) SW6 = ON (1)	Boilerless Electric Heat
		SW5 = ON (1) SW6 = ON (1)	Hydronic Heating
SW7	Hot Gas Reheat (HGRH)	SW7 = OFF (0)	HGRH Disabled
		SW7 = ON (1)	HGRH Enabled
SW8	Waterside Economizer (WSE)	SW8 = OFF (0)	Waterside Economizer Disabled
		SW8 = ON (1)	Waterside Economizer Enabled
SW9	WSHP I/O Expansion Application Select	SW9 = OFF (0)	Single Compressor Application
		SW9 = ON (1)	Two Compressor Application
SW10	Single Compressor: Speed	SW10 = OFF (0)	Single Speed Compressor
		SW10 = ON (1)	Dual Speed Compressor
	Two Compressor: Lead Compressor Select	SW10 = OFF (0)	Compressor 1 is Lead
		SW10 = ON (1)	Compressor 2 is Lead

NOTE: The functionality of SW10 depends on the setting of SW9. If SW9 is OFF, SW10 will be for Single Compressor Speed. If SW9 is ON, SW10 will be for Lead Compressor Select.

Figure 3: MT2310 I/O Expansion DIP Switches

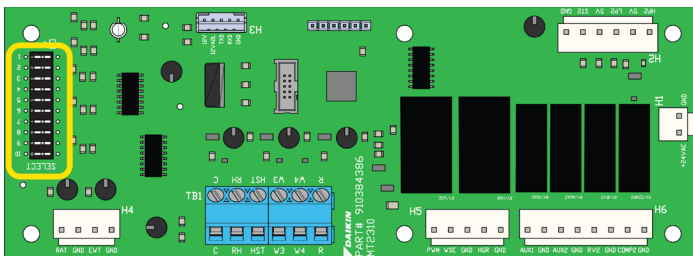

Functionality

The MT2300 is the base unit controller for the Daikin Applied water source heat pump control platform. The MT2300 controls the heat pump in all modes of operation, including:

- Single Stage Compressor
- Single/Two-speed Fan
- Isolation Valve / Pump Request
- Reversing Valve On/Off
- Alarm (Dry Contacts)
- Network Integration (with a BACnet Communications Module)

The controller can be used with thermostat or sensor control.

All MT2300 unit controller inputs must be activated by dry contacts powered by the control board's power terminals or approved Daikin Applied sensors. No solid state devices (Triacs) may be used to operate MT2300/MT2310 unit controller inputs. No external power sources may be used to operate MT2300. All units must be properly grounded per local code requirements. See the Installation and Maintenance bulletin specific to your Water Source Heat Pump.

Connecting a MT2310 expansion board to the main controller allows:

- Compressor High Capacity On/Off Control
- Second Compressor
- Second Compressor Reversing Valve On/Off
- Variable Speed Fan Control
- Water Side Economizer Control
- Active Hot Gas Reheat or Low Capacity Dehumidification Options
- Boilerless & Supplemental Auxiliary Heating Options
- The Third and Fourth Thermostat Heating Stage (W3 and W4) Input
- Hydronic Heating Control

The I/O of the MT2300 unit controller can be extended to support additional functions with the MT2310 expansion board.

Your Daikin Applied water source heat pump will be delivered with the correct unit controls installed to support the specific unit configuration.

Operating Modes

- **Occupied Mode** – When in the occupied mode, the unit will be controlled to its occupied setpoint conditions. The occupancy mode can be established by a BACnet communication signal, from a room sensor equipped with “Occupied/Unoccupied” mode functions, or a thermostat equipped with an “Occupied/Unoccupied” mode switch. The occupancy state will be displayed on sensors equipped with a status indicator.
- **Unoccupied Mode** – When in the unoccupied mode, the unit will be controlled to its unoccupied setpoints. The occupancy state will be displayed on sensors equipped with a status indicator.

A contact closure between terminals U and C on the MT2300 unit controller will place the unit into the unoccupied mode for night setback/setup operation. Thermostat equipped units will be controlled from Y2, W2, W3, W4 and DH inputs. The fan will cycle according to a call for cooling, heating, or dehumidification.

- **Override Mode** – A momentary (4 to 10 seconds) press of the “Override” button on the thermostat or room sensor during the unoccupied mode will cause the unit to operate in the occupied mode for up to two hours, for after-hours heating, cooling or dehumidification. “OVERRIDE” will be displayed on sensors equipped with override button and status indicator.
- **“Energy Save” Standby** – BACnet units configured for Room Sensor Control can receive a signal from the Building Automation System (BAS) to initiate the energy savings mode. This mode is typically initiated by the BAS with smart grid technologies to save energy. The savings are driven by reducing peak electrical demand for the building. Once initiated, the MT2300 SmartSource® unit controller will reset its effective setpoint to minimize compressor operation. “E-SAVE” will be displayed on sensors equipped with bypass mode annunciation capabilities.
- **Remote Shutdown** – When the unit is in the remote shutdown mode, unit operation is suspended. A contact closure between terminals E and C on the MT2300 unit controller will place the unit into remote shutdown mode.

Safety Inputs (HPS, LPS, SLTS, COS)

The control inputs are High Pressure Switch (HPS), Low Pressure Switch (LPS), Suction Line Temperature Sensor (SLTS), Condensate Overflow Sensor (COS). These inputs are active while the unit is in any occupancy mode. Protect unit components by disrupting normal operation as follows:

- **High Pressure Switch (HPS)** – Normally closed switch that opens on a high refrigerant pressure condition. Control generates a high pressure fault and disables the compressor output when the switch is open. High pressure inputs are only valid when the compressor output relay is energized.
- **Low Pressure Switch (LPS)** – Normally closed switch that opens on a low refrigerant pressure condition. Control generates a low pressure fault and disables the compressor output when the switch is open.
- **Suction Line Temperature Sensor (SLTS)** – Monitors refrigerant suction line temperature. When the suction temperature drops below the cutout setpoint, the control generates a low temperature fault and disables the compressor output.
- **Condensate Overflow Sensor (COS)** – Senses condensate level in condensate pan. When the sensor indicates a potential overflow condition, the control generates a condensate overflow fault and disables the compressor output. Condensate overflow alarm is disabled in the heating mode.

Control Outputs

- **Thermostat Alarm Output:** Will be energized when there are fault conditions presently active. Without any fault conditions active, the alarm output shall be de-energized. When energized the onboard relay closes the connection between TB4 ALM and COM. For a 24VAC output from ALM, connect a 24VAC source to COM.
- **Isolation Valve/Pump Request [IV/PR (H6)]:** is selectable to be energized when the compressor is off (normally closed), or when the compressor is on (normally open), by moving the wire lead to the appropriate terminal.

Figure 4: TB4, H5, and H6 Terminals on MT2300 Board

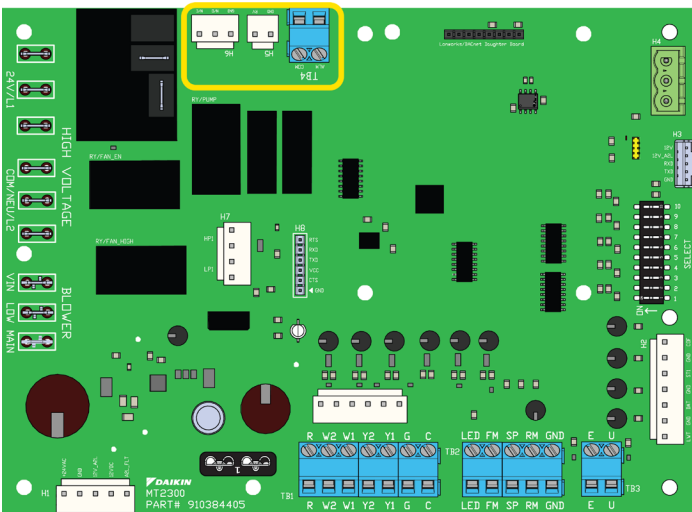
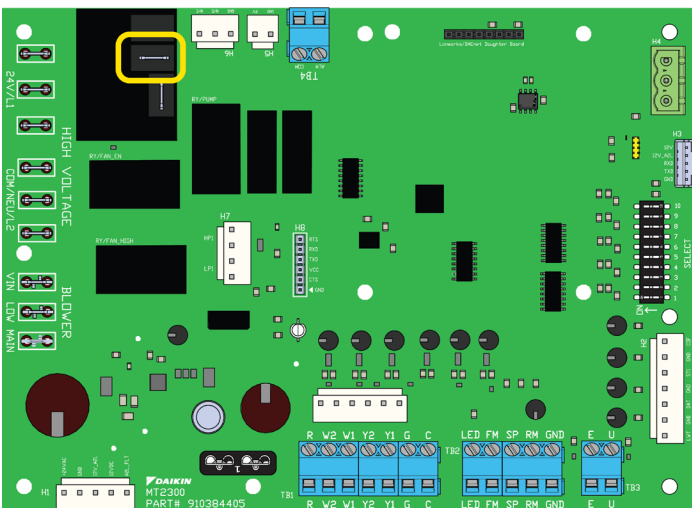

Figure 5: Compressor Relay Terminals on MT2300 Board



- **Compressor Relay:** Line or low voltage output used to control compressor. (On/Off)

LED Indicators

When the unit controller or I/O boards are communicating a certain fault or mode, the LED indicator will flash a designated pattern or sequence. See below for the location of the LED indicator on each board.

Figure 6: LED Indicator on MT2300 Board

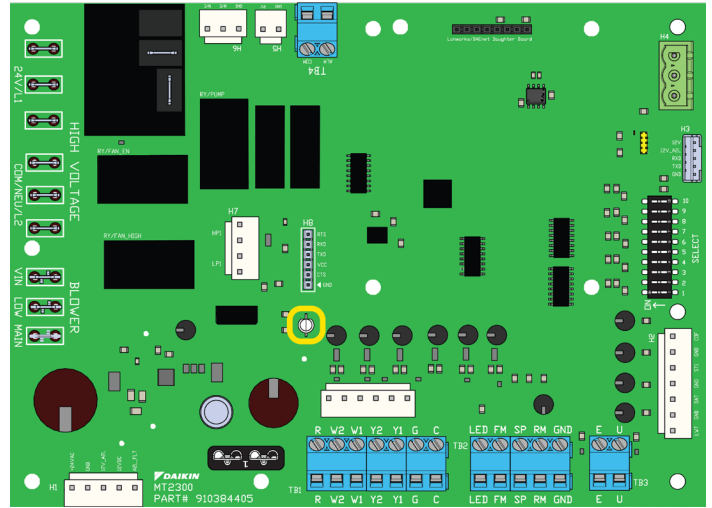
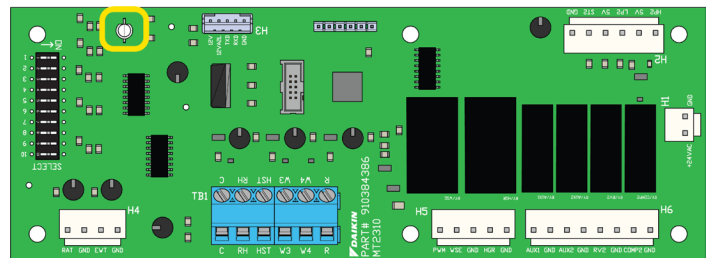

Figure 7: LED Indicator on MT2310 I/O Expansion Board



Operation

Start-Up

The MT2300 unit controller's valve or pump request terminal [IV/PR (H6)] is an output signal to external devices to allow water flow as required by the heat pump. The IV/PR (H6) terminal follows compressor operation inversely if connected to the normally open terminal and simultaneously when connected to the normally closed terminal. The IV/PR (H6) terminal can be used as a signal to an external pump or valve to enable flow to the unit. The compressor start is delayed for 60 seconds after the IV/PR (H6) output is energized.

Table 5: IV/PR(H6) Terminal and Compressor Operation

IV/PR(H6)	Compressor On	Compressor Off
Normally Open	24 VAC	0 VAC
Normally Closed	0 VAC	24 VAC

Fan Speed Selection

The SW1-SW4 configuration switches on the MT2310 I/O expansion module allow CFM settings to be field adjustable with some fan options. Fan speed control optimizes unit fan speed based on thermostat/room sensor inputs.

The variable speed fan configuration switches allow for manually setting an optimal fan speed specific to the application requirements. The four primary speed profiles are selected using SW1 and SW2. SW3 reduces the heating and cooling speeds by 15%, and the SW4 switch selects the fan speed when in Fan Only mode (subject to the operational rules below).

Fan Only SW4

OFF = 20%

ON = Cool Stage 1 speed (Does not affect heat or cool mode fan speeds)

General Fan Operation Rules

50% minimum whenever heating or cooling

100% for Auxiliary Electric Heat

Hydronic heating/cooling = Heat Stage 1/Cool Stage 1

DEHUM = Cool Stage 1 minus 10% (50% minimum)

Table 6: I/O Expansion Module Configuration Switch

Fan Speed Row	Switch 1	Switch 2	Switch 3	Fan Only ¹	Cool Stage 1	Cool Stage 2	Heat Stage 1	Heat Stage 2
1	OFF	OFF	OFF	20%	80%	100%	80%	100%
2	ON	OFF	OFF	20%	70%	90%	70%	90%
3	OFF	ON	OFF	20%	60%	80%	60%	80%
4	ON	ON	OFF	20%	50%	70%	50%	70%
5	OFF	OFF	ON	20%	65%	85%	65%	85%
6	ON	OFF	ON	20%	55%	75%	55%	75%
7	OFF	ON	ON	20%	50%	65%	50%	65%
8	ON	ON	ON	20%	50%	55%	50%	55%

¹ See "Fan Only SW4" section above.

NOTE: Refer to Figure 3 for configuration switch location.

BACnet Communication Module

On units with an optional BACnet communication module, fan speeds can be set through network communications to 1% resolution of duty cycle. For hydronic or compressorized modes, the range is 50-100%, and for fan only mode, the range is 10-100%. When enabled, the network fan speed settings will override the local configuration switches. When the MT2310 status LED interval is yellow instead of Off, this indicates that the network is overriding the fan speed settings.

Sequence Of Operation

Fan Only

On a call for fan the fan starts immediately through the activation of the Thermostat G terminal or Room Sensor Fan Switch.

LED Activity	Type	Color	Description
1 Flash	Mode	Green	No Call for Heating/Cooling/Dehumidification
4 Flash	Mode	Green	Call for Fan Only

NOTE: If configuration switch SW2 on the main control board is OFF the fan will run continuous whenever there is a power supply to the unit. For cycling fan operation configuration switch SW2 needs to be ON.

Cooling

LED Activity	Type	Color	Description
1 Flash	Mode	Green	No Call for Heating/Cooling/Dehumidification
2 Flash	Mode	Green	Call for Cooling

The compressor minimum off timer, and random start timer must expire before the compressor will be energized. On a call for 1st stage cooling from a thermostat or network setpoint, the H6 output on the MT2300 board is activated to open the motorized valve to allow water flow through the heat exchanger. The fan starts immediately (unless it is already on through activation of the G terminal by the thermostat fan switch "ON" or a wall sensor command) at "FAN ONLY" setting. The compressor starts after 60 seconds to make sure the motorized valve has fully open for proof of water flow and the fan CFM output increases. The compressor minimum on timer of 180 seconds starts. The reversing valve will de-energize 5 seconds after the compressor starts. The fan CFM output is now determined by the MT2310 I/O

board configuration switches SW1-SW4 and the corresponding stage 1 CFM. If a two stage thermostat is used, a further demand for cooling will change (increase) the CFM output of the EC fan motor.

When the room setpoint conditions are satisfied, the compressor will shut off and the fan will either shut off (fan switch "AUTO") or continue to run (fan switch "ON" or configuration switch SW2 is OFF). The compressor minimum off timer of 360 seconds will start.

If additional capacity is needed on two stage or two compressor units, the unit will initiate stage 2 cooling. When the room setpoint conditions are satisfied, the stage 2 compressor will shut off first followed by the stage 1 compressor.

If there is a simultaneous call for dehumidification and cooling, cooling will take priority. Once the cooling setpoint is met and the call removed, and if a dehumidification call remains, the unit will continue compressor operation and open the hot gas reheat valve to provide dehumidification.

Heating

LED Activity	Type	Color	Description
1 Flash	Mode	Green	No Call for Heating/Cooling/Dehumidification
3 Flash	Mode	Green	Call for Heating

The compressor minimum off timer, and random start timer must expire before the compressor will be energized. On a call for 1st stage heating, from a thermostat or network setpoint, the H6 output on the MT2300 board is activated to open the motorized valve to allow water flow through the heat exchanger. The fan starts immediately (unless it is already on through activation of the G terminal by the thermostat fan switch "ON" or a wall sensor command) at low CFM. The compressor starts after 60 seconds to make sure the motorized valve has fully open for proof of water flow and the fan CFM output increases. The compressor minimum on timer of 180 seconds starts. The reversing valve will energize 5 seconds after the compressor starts. The fan output is now determined by the MT2310 I/O board configuration switches SW1-SW4 and the corresponding stage 1 CFM. If a two stage thermostat is used, a further demand for heating will change (increase) the CFM output of the EC fan motor.

When the room setpoint conditions are satisfied, the compressor will shut off and the fan will either shut off (fan switch "AUTO") or continue to run (fan switch "ON" or configuration switch SW2 is OFF). The compressor minimum off timer of 360 seconds starts.

If additional capacity is needed, on two stage or two compressor units, the unit will initiate stage 2 heating. When the room setpoint conditions are satisfied, the stage 2 compressor will shut off first followed by the stage 1 compressor.

Boilerless Electric Heat Mode

Units equipped with the boilerless electric heat option include an entering water temperature sensor. On a call for heating the fan starts immediately (unless it is already enabled through activation of the G terminal from the thermostat fan switch "ON" or a wall sensor command.) at "FAN ONLY" setting. The H6 output on the MT2300 board is activated to open the motorized

valve allowing water flow thru the heat exchanger. If the entering water temperature is below set point, (55°F standard units or 28°F for geothermal units), the MT2300 controller will disable the compressor, increase the fan speed to electric heat CFM and energize a 24VAC output to the electric heat control circuit. When the room setpoint conditions are satisfied, the electric heater will turn off and the fan will either cycle off (fan switch "AUTO") or continue to operate (fan switch "ON" or configuration switch SW2 is OFF). If the entering water temperature is above setpoint, the unit will operate in compressor heating mode. The setpoints are adjustable by the BAS.

Supplemental Electric Heat Mode

On a call for supplemental electric heat (W3) or BAS setpoint, the compressor will continue to operate, the fan speed will increase to the electric heat setting and electric heating will energize. For units equipped with two stages of electric heat, W4 or BAS setpoint will turn on second stage of electric heat.

Hydronic Heat Mode

For units with the factory installed hydronic heat option, a hydronic coil, 3-way valve, and entering water temperature sensor are included with this option. The purpose of this mode is to satisfy the heating demand by using the elevated loop water temperature between 90°F and 120°F.

On a call for 1st stage heating with entering loop water above 90°F, the H6 output on the MT2310 I/O expansion module is activated to open the motorized valve diverting water flow to the hydronic coil. The fan starts after 30 seconds (unless it is already activated by the thermostat or room sensor). The fan output is determined by the MT2310 I/O expansion module configuration switches. When the room setpoint conditions are satisfied, the 3-way valve will close and the fan will either shut off (fan switch "AUTO") or continue to run (fan switch "ON" or configuration switch SW2 is OFF). When entering loop water temperature is below 90°F, standard heating operation resumes.

Smart Dehumidification (Hot Gas Reheat)

LED Activity	Type	Color	Description
1 Flash	Mode	Green	No Call for Heating/Cooling/Dehumidification
6 Flash	Mode	Green	Call for Dehumidification

This mode requires optional hot gas reheat and a humidistat input to the MT2310 I/O expansion module. This option also utilizes airflow management. If the space cooling temperature setpoint is satisfied, but the humidity is above the space humidity setpoint, the dehumidification mode is activated. The return air temperature must be 68°F or greater.

On a call for smart dehumidification, the fan will energize at its fan only setting, the pump will energize. After the 60 second flow timer and the compressor minimum off timer expire (360 seconds), the fan will operate at the dehumidification setting, the compressor will energize at full load operation and the control board hot gas reheat output is energized to open the hot gas reheat valve, sending hot gas to the reheat coil. The return air is cooled and reheated to near space temperature. When the space

humidity setpoint is satisfied the compressor will turn off and the fan will operate according to its fan setting.

During smart dehumidification operation, a call for cooling will close the hot gas reheat valve and the unit will resume normal cooling operation until the space temperature is satisfied.

If the cooling call ends and a dehumidification call is still present, the unit will open the hot gas reheat valve and maintain compressor operation until the dehumidification call is no longer present.

Simplified Dehumidification (Thermostat Control Only)

This mode helps control space humidity by reducing the CFM as the space temperature approaches the thermostat cooling setpoint without hot gas reheat. The return air temperature must be 68°F or greater for 1st stage operation. A multi-stage thermostat is used to provide compressor cooling with multiple airflows. Using a 3 cooling stage thermostat the following occurs: On a call for 1st stage cooling (Terminal TB1-3, HST on the MT2310 I/O expansion module), the H6 output on the MT2300 board enables the pump or motorized valve to direct water flow through the heat exchanger. The fan starts immediately (unless it is already on) at the dehumidification CFM. If the return air temperature is 68°F or greater, the compressor starts after the 60 second flow timer and the 360 second compressor minimum off timer has expired. The compressor minimum on timer of 180 seconds starts. On a call for cooling, stage 2 (Terminal Y1), the fan output will increase to the cooling stage 1 CFM. On a call for cooling, stage 3 (Terminal Y2), the fan output will increase to the cooling stage 2 CFM. The unit attempts to satisfy cooling at the lowest possible CFM for maximum dehumidification. When the room setpoint conditions are satisfied, the compressor will shut off and the fan will either shut off (fan switch "AUTO") or continue to run (fan switch "ON" or configuration switch SW2 is OFF).

Analog Humidity Sensor Input

- Any of the dehumidification options described can also be used with an optional 0-10VDC relative humidity sensor.
- An analog humidity sensor is intended to be an option for units with BACnet communications to allow the relative humidity value to be viewed and the dehumidification setpoint to be adjusted via network communications.
- When an analog humidity sensor is used, and optional Humidity Sensor Failure alarm can be configured to indicate if the sensor reading has become unreliable. The Sensor Failure Alarm feature is disabled by default, and can be activated via network communications.
- While an analog humidity sensor can be used on units without network communications, there will be no way to the relative humidity or adjust the relative humidity setpoint, so a humidistat is recommended.

Waterside Economizer

This mode requires the optional factory-installed waterside economizer (WSE). A hydronic economizer coil, 3-way motorized valve and an entering water temperature (EWT) sensor are added

to the unit.

Second and third stage cooling calls will request simultaneous hydronic cooling and compressor operation. This operation will be allowed when the EWT is above 53°F to limit the risk of a frozen airside coil.

For Single Stage Units with WSE Option

Hydronic cooling operation is adjustable between 50°F and 70°F via BACnet (factory default of 65°F).

- On a call from Y1 or cooling stage 1 setpoint, and the EWT is below the hydronic cooling setpoint, but above 45°F, the unit will operate in hydronic cooling mode. (The 3-way valve is energized and the fan operates at the hydronic cooling CFM setting)
- On a call from Y2 of the thermostat or second stage cooling setpoint, and the EWT is below the hydronic cooling setpoint, but between 45°F and 53°F, when the loop fluid is designated as "Water" (SW3 = OFF), the unit will continue to operate in hydronic cooling mode. If the EWT is below the hydronic cooling setpoint, but above 53°F, the unit will operate in hydronic cooling mode and full load mechanical cooling. (The fan will operate at the full load cooling CFM).
- On a call from Y2 of the thermostat or second stage cooling setpoint, and the EWT is below the hydronic cooling setpoint, but between 45°F and 53°F, when the loop fluid is designated as "Glycol" (SW3 = ON) the unit will operate in full load mechanical cooling. If the EWT is below the hydronic cooling setpoint, but above 53°F, the unit will operate in hydronic cooling mode and full load mechanical cooling. (The fan will operate at the full load cooling CFM).

If at any time the EWT rises above the entering water temperature setpoint plus 5°F (while operating) or below 45°F, the 3-way valve will de-energize, disabling WSE operation.

If WSE is not available due to entering water temperatures out of range, the sequence becomes:

- On a call from Y1 or cooling stage 1 setpoint, the unit operates at full load mechanical cooling. (The fan will operate at the full load cooling CFM).

On a call from Y2 or cooling stage 2 setpoint, status the same as above.

For 2-Stage and Two Compressor Units with WSE Option

Hydronic cooling operation is adjustable between 50°F and 70°F (factory default of 65°F).

- On a call from Y1 or cooling stage 2 setpoint, and the EWT is below the hydronic cooling setpoint, but above 45°F, the unit will operate in hydronic cooling mode. (The 3-way valve is energized and the fan operates at the hydronic cooling CFM setting).
- On a call from Y2 of the thermostat or second stage cooling setpoint, and the EWT is below the hydronic cooling setpoint, but between 45°F and 53°F, when the loop fluid is designated as "Glycol" (SW3 = ON), the unit will operate in part load mechanical cooling. If the EWT is below the

hydronic cooling setpoint, but above 53°F, the unit will operate in hydronic cooling mode and full load mechanical cooling. (The fan will operate at the full load cooling CFM).

- On a call from Y2 of the thermostat or second stage cooling setpoint, and the EWT is below the hydronic cooling setpoint, but between 45°F and 53°F, when the loop fluid is designated as “Water” (SW3 = OFF,) the unit will continue to operate in hydronic cooling mode. If the EWT is below the hydronic cooling setpoint, but above 53°F, the unit will operate in hydronic cooling mode and part load mechanical cooling. (The fan will operate at the part load cooling CFM).
- On a call from Y3 of the thermostat or third stage cooling setpoint, and the EWT is below the hydronic cooling setpoint, but between 45°F and 53°F, when the loop fluid is designated as “Water” (SW3 = OFF), the unit will continue to operate in hydronic cooling mode. If the EWT is below the hydronic cooling setpoint, but above 53°F, the unit will operate in hydronic cooling mode and full load mechanical cooling. (The fan will operate at the full load cooling CFM).
- On a call from Y3 of the thermostat or third stage cooling setpoint, and the EWT is below the hydronic cooling setpoint, but between 45°F and 53°F, when the loop fluid is designated as “Glycol” (SW3 = ON), the unit will continue to operate in full load mechanical cooling. If the EWT is below the hydronic cooling setpoint, but above 53°F, the unit will operate in hydronic cooling mode and full load mechanical cooling. (The fan will operate at the full load cooling CFM).

If at any time the EWT rises above the entering water temperature setpoint plus 5°F (while operating) or below 45°F, the 3-way valve will de-energize, disabling WSE operation.

If WSE is not available due to entering water temperatures out of range, the sequence becomes:

- On a call from Y1 or cooling stage 1 setpoint, the unit operates at part load mechanical cooling. (The fan will operate at the part load cooling CFM).
- On a call from Y2 or cooling stage 2 setpoint, status the same as above
- On a call from Y3 or cooling stage 3 setpoint, the unit goes to full load mechanical cooling. (The fan will operate at the full load cooling CFM).

The minimum off timer of 360 seconds starts. If the loop temperature increases above the changeover temperature, waterside economizer mode will be suspended and the unit will resume normal mechanical cooling mode with stage 1 of the thermostat or network setpoint now starting the compressor.

NOTICE

To prevent compressor cycling and all compressors from starting up together after loss of power, the required minimum on/off time default is 300 seconds plus the random restart of 0 to 60 seconds. This may cause the compressor time delay to be longer than indicated above.

NOTICE

For a unit with both water side economizer and hot gas reheat, Y3 from the thermostat will be wired to W4 on the MT2310 I/O expansion module.

Electric Heat Controls

W3

The W3 (TB1-4) terminal in the MT2310 I/O expansion module enables the first stage of electric heat.

W4

The W4 (TB1-5) terminal on the MT2310 I/O expansion module enables the second stage of electric heat except on units configured for both Waterside Economizer and Dehumidification.

Supplemental Electric Heat Control

The supplemental electric heating option provides additional stages of heating that can be used in conjunction with compressor heating, or exclusively if the compressor is not available for heating.

General Rules

- Supplemental electric heater and the compressor may operate simultaneously.
- Minimum Compressor ON and OFF timers do not apply to electric heat control.

Operation

Fan Main Output: will turn ON and the Fan PWM signal will be at “Auxiliary Heat” duty cycle when:

- Any auxiliary heat output is energized.
- For 30 fixed seconds after all auxiliary heat outputs have been de-activated.

Electric Heat Outputs: are allowed to energize when either condition exists:

- Inter-Stage ON timer must be expired.
- Compressor is not available for heating.

When Compressor is Available

- Auxiliary Heat Stage 1 output energizes upon activation of Heating – Stage 3.
- Auxiliary Heat Stage 2 output energizes upon activation of Heating – Stage 4, except on units configured for both Waterside Economizer and Dehumidification.

When Compressor is Unavailable

- Auxiliary Heat Stage 1 output energizes upon activation of “Heating – Stage 1.
- Auxiliary Heat Stage 2 output energizes upon activation of Heating – Stage 4, except on units configured for both Waterside Economizer and Dehumidification.

Boilerless Heat Control

- Turns on the heater when the entering water temperature is less than setpoint (default is 55°F), the temperature set point is adjustable through the network.
- For geothermal applications, the heater turns on when the entering water temperature is less than setpoint (default

28°F).

NOTICE

In both cases, the compressor is shut down.

Unit Status

Unoccupied Operation – Stand Alone Thermostat Control

The board will be in unoccupied mode if the unoccupied terminal (U) is grounded.

LED Activity	Type	Color	Description
5 Flash	Mode	Green	Unoccupied Mode Active

Figure 8: Terminal “U” - Grounded for Unoccupied

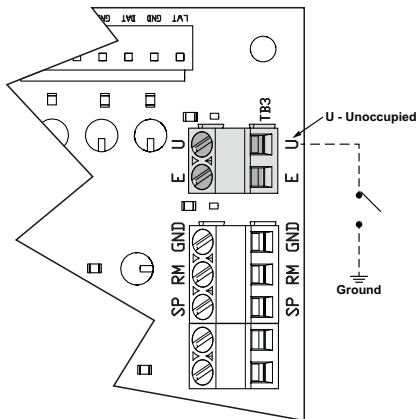

Remote Shutdown

LED Activity	Type	Color	Description
Rapid Flash	Mode	Green	Emergency Shutdown

When the TB3-E terminal is grounded, the MT2300 unit controller enters remote shutdown mode. Remote shutdown is provided so that when properly connected to a building automation system, remote switch, etc., the E terminal can be used to shut down the water source heat pump.

When in remote shutdown (E terminal grounded), control inputs have no affect upon unit operation. No faults or modes have higher priority than remote shutdown. See [Table 8 on page 16](#).

When the unit is in remote shutdown mode, the following occurs:

1. The compressor de-energizes (if enabled).
2. The fan de-energizes (if enabled).
3. Fault terminal (ALM) will remain de-energized because emergency shutdown is a “mode.”

When the E terminal is no longer grounded the unit will automatically return to normal operation.

NOTICE

The remote shutdown input (E) will suspend unit operation. Disconnect power when servicing the unit/controller.

Figure 9: Terminal “E” - Grounded for Remote Shutdown

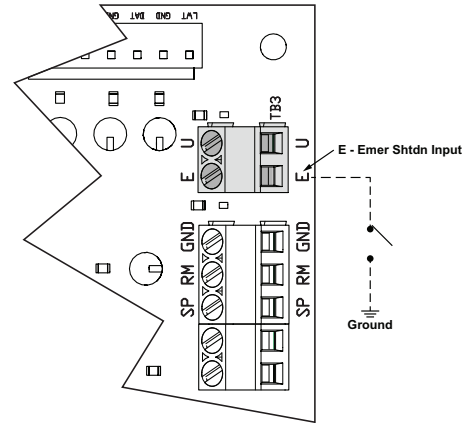

Thermostat Inputs

Inputs (G, Y1, Y2, W1, W2, W3, and W4)

For units with both waterside economizer and hot gas reheat, the only thermostat inputs used during unoccupied operation are W4, and W2/W3, which when energized will activate Cooling Mode or Heating Mode respectively. Inputs G, Y1, Y2, and W1 have no effect during unoccupied mode.

NOTICE

The board DIP switches can be configured such that W4 can function as Y3.

For all other units, the only thermostat inputs used during unoccupied operation are Y2, and W2/W3/W4, which when energized will activate Cooling Mode or Heating Mode respectively. Inputs G, Y1, and W1 have no effect during unoccupied mode.

Waterside Economizer/Dehumidification

The humidistat input (TB1-3, HST) on the I/O expansion board, when energized from the thermostat, enables Waterside Economizer or Dehumidification operation on units configured for one of the functions or the other.

On units configured for both Waterside Economizer and Dehumidification:

- The humidistat input (TB1-3, HST) on the I/O expansion board enables dehumidification.
- The Y1 input on the MT2300 baseboard (TB1-1), when energized from the thermostat, enables Waterside Economizer operation.
- The W4 input (TB1-5) on the MT2310 I/O expansion module

will act as a Y3 third stage of cooling.

Fault Modes

Status LED Indication

The MT2300 and the MT2310 boards each have a three-color status LED that provide operational mode and alarm notification. Mode LED flashes have an ON/OFF interval of 250ms ON and 750ms OFF between cycles. Fault LED flashes have an ON/OFF interval of 250ms ON and 1.5 second OFF between cycles. Rapid LED flashes are ON/OFF at 150ms intervals with no interval cycle.

Table 7: Room Sensor Status LED

LED On Time (Sec)	LED Off Time (Sec)	Operating Mode
0.5	0.5	Alarm Condition or Network "Wink" Operation Active
0.0	Continually	Bypass Mode is Active
0.5	5.5	Unoccupied Mode
5.5	0.5	Standby Mode
Continually	0.0	Occupied Mode

Faults and Modes

Table 8: Priority Level of Faults and Modes with Resets

Alarm Enumeration (BACnet)	Fault	Indication	Reset ¹
1	No Alarm	Normal operation	NA
2	MT2310 Communication Failure	Single compressor unit with SW 8 set to ON position	A
3	Incompatible Software	Incorrect Software Part or Version Numbers	P
4	Invalid Configuration	Base & I/O Exp Application Mismatch or MT2310 detected but not required (SW 8)	P
5	A2L Alarm	A2L refrigerant leak detected	A
6	A2L Error - Power	A2L mitigation control is not powered	A
7	Compressor Low Voltage	"Brownout" condition exists	A
8	Comp 1 High Pressure	Compressor 1 high pressure switch opened	T,N
9	Comp 2 High Pressure	Compressor 2 high pressure switch opened	T,N
10	Comp 1 Low Pressure	Compressor 1 low pressure switch opened	T,N
11	Comp 2 Low Pressure	Compressor 2 low pressure switch opened	T,N
12	Comp 1 Suction Temp Sensor	Compressor 1 suction temp sensor reading "out of range"	N
13	Comp 2 Suction Temp Sensor	Compressor 2 suction temp sensor reading "out of range"	N
14	Leaving Water Temp (LWT) Sensor	LWT sensor not present (SW 4 = ON)	N

Alarm Enumeration (BACnet)	Fault	Indication	Reset ¹
15	Freeze Fault Detect (FFD)	LWT sensor temp below freeze setpoint (SW 4 = ON)	T,N
16	Comp 1 Low Suction Temp (ST1)	ST1 sensor temp below minimum setpoint	A,T,N ²
17	Comp 2 Low Suction Temp (ST2)	ST2 sensor temp below minimum setpoint	A,T,N ²
18	A2L Error - Sensor	A2L sensor lost communication or reported failure	A
19	Control Temp Sensor Failure	Room Temp and Return Air Temp sensor reading "out of range"	N
20	Entering Water Temp (EWT) Sensor Failure	EWT sensor reading "out of range"	N
21	Room Temp Sensor Failure	Room temp sensor reading "out of range"	N
22	Return Air Temp Sensor Failure	RAT sensor reading "out of range"	N
23	Space RH Sensor Failure	Space RH sensor reading "out of range"	N
24	Low Entering Water Temp (EWT)	EWT sensor reading below minimum setpoint	A
25	Condensate Overflow	Condensate overflow sensor indicates water present	A,N
26	Waterside Economizer (WSE) Low Temp	WSE temp sensor reading below minimum setpoint	A

NOTE 1: "A" = Auto Reset, "T" = Tenant Override Button Reset, "N" = Network Reset, "P" = power cycle only

NOTE 2: Low suction temperature faults have "Intelligent Reset" logic - 3 faults in a 24 hour period disables the auto reset function.

Table 9: MT2300 Unit Controller Status LEDs

LED Activity	Type	Color	Description
Steady ON	Fault	Yellow	MCU Not Programmed
Steady ON	Fault	Red	MCU Hardware Failure
1 Flash	Fault	R-Y-G	Invalid Configuration
2 Flash	Fault	R-Y-G	Incompatible Software
1 Flash	Fault	R-Y	I/O Exp Board Communications Fail
1 Flash	Mode	G-Y	Service / Test Mode Active
Rapid Flash	Fault	Red	A2L Mitigation – Refrigerant Leak
1 Flash	Fault	Red	Compressor 1 High Pressure
2 Flash	Fault	Red	Compressor 1 Low Pressure
3 Flash	Fault	Red	Compressor 1 Suction Temp Sensor Out of Range
4 Flash	Fault	Red	Compressor 1 Low Suction Temp
5 Flash	Fault	Red	Compressor 2 High Pressure
6 Flash	Fault	Red	Compressor 2 Low Pressure
7 Flash	Fault	Red	Compressor 2 Suction Temp Sensor Out of Range
8 Flash	Fault	Red	Compressor 2 Low Suction Temp
9 Flash	Fault	Red	A2L Mitigation – Control Board Without Power

LED Activity	Type	Color	Description
Rapid Flash	Mode	Yellow	A2L Mitigation – Refrigerant Sensor Out of Range
1 Flash	Fault	Yellow	Compressor Low Voltage Brownout
2 Flash	Fault	Yellow	Freeze Fault Detect (FFD)
3 Flash	Fault	Yellow	Control Temp Sensor Out of Range
4 Flash	Fault	Yellow	Entering Water Temp Sensor Out of Range
5 Flash	Fault	Yellow	Leaving Water Temp Sensor Out of Range
6 Flash	Fault	Yellow	Relative Humidity Sensor Out of Range
7 Flash	Fault	Yellow	Condensate Overflow
8 Flash	Fault	Yellow	Space Temp Sensor Out of Range
9 Flash	Fault	Yellow	Return Air Temp Sensor Out of Range
Rapid Flash	Mode	Green	Emergency Shutdown
1 Flash	Mode	Green	No Call for Heating / Cooling / Dehumidification
2 Flash	Mode	Green	Call for Cooling
3 Flash	Mode	Green	Call for Heating
4 Flash	Mode	Green	Call for Fan Only
5 Flash	Mode	Green	Unoccupied Mode Active
6 Flash	Mode	Green	Call for Dehumidification
7 Flash	Mode	Green	Low Entering Water Temp
8 Flash	Mode	Green	HGRH Low Return Air Temp Cutout
9 Flash	Mode	Green	WSE Low Temp Cutout

Table 10: MT2310 I/O Expansion Board Status LEDs

LED Activity	Type	Color	Description
1 Flash	Mode	Green ¹	Variable Speed Fan OFF
2 Flash	Mode	Green ¹	Variable Speed Fan ON: 0 to 20%
3 Flash	Mode	Green ¹	Variable Speed Fan ON: 21 to 30%
4 Flash	Mode	Green ¹	Variable Speed Fan ON: 31 to 40%
5 Flash	Mode	Green ¹	Variable Speed Fan ON: 41 to 50%
6 Flash	Mode	Green ¹	Variable Speed Fan ON: 51 to 60%
7 Flash	Mode	Green ¹	Variable Speed Fan ON: 61 to 70%
8 Flash	Mode	Green ¹	Variable Speed Fan ON: 71 to 80%
9 Flash	Mode	Green ¹	Variable Speed Fan ON: 81 to 90%
10 Flash	Mode	Green ¹	Variable Speed Fan ON: 91 to 100%
Steady ON	Fault	Yellow	MCU Not Programmed
Steady ON	Fault	Red	MCU Hardware Failure
1 Flash	Fault	R–Y–G	Invalid Configuration
2 Flash	Fault	R–Y–G	Incompatible Software
1 Flash	Fault	R–Y	Base Board Communications Failure
Rapid Flash	Fault	Red	A2L Mitigation - Alarm Condition

NOTE 1: When the BACnet network is overriding the fan speed DIP switch selection, the LED interval color will be yellow instead of green.

Brownout

LED Activity	Type	Color	Description
1 Flash	Fault	Yellow	Compressor Low Voltage Brownout

Brownout condition is provided to protect the water source heat pump’s motor electrical damage due to low voltage conditions.

The MT2300 unit controller is designed to monitor the 24VAC power supply to the board. If the line voltage supplied to the water source heat pump drops, the 24VAC supply to the control board will also drop. When the line voltage supplied to the unit drops below approximately 80% of the unit nameplate rated value, the controller goes into brownout condition. The controller remains in brownout condition until line voltage returns to approximately 90% of the unit nameplate value.

When in brownout condition, thermostat and control inputs have no affect upon unit operation. Remote shutdown and brownout conditions have the same level of priority. See [Table 8 on page 16](#).

When the unit is in brownout condition the following occurs:

1. The compressor de-energizes.
2. The IV/PR (H6) output will change state. (On to Off/Off to On).
3. The fan de-energizes.
4. Alarm terminal (TB4-ALM) energizes (fault). TB4-ALM will close to AB4-COM to indicate an alarm signal. When the line voltage supplied to the unit returns to acceptable levels (90% of nameplate) the controller returns to the current mode.

High/Low Pressure Faults (HP/LP)

Normally closed high and low refrigerant pressure switches help protect the water source heat pump from excessively high or low refrigerant pressures. The MT2300 unit controller monitors these switches individually. If the compressor is running and the HP circuit is open, the controller enters a pressure fault mode. If the LP circuit is open after a time delay (default of 30 seconds, adjustable if a communication module is present) the controller enters a low pressure fault mode.

LED Activity	Type	Color	Description
1 Flash	Fault	Red	Compressor 1 High Pressure
2 Flash	Fault	Red	Compressor 1 Low Pressure
5 Flash	Fault	Red	Compressor 2 High Pressure
6 Flash	Fault	Red	Compressor 2 Low Pressure

See [Table 8 on page 16](#).

When the unit is in high or low pressure fault modes the following occurs:

1. The faulty compressor de-energizes. For two compressor units, when the either the high or low pressure switch on circuit 1 opens, the circuit 1 compressor turns off and the unit uses the compressor on circuit 2, if available.
2. The IV/PR (H6) output will change state. (On to Off / Off to On).

3. The fan de-energizes if no compressors are available.
4. The alarm terminal (TB4-ALM) energizes (fault). TB4-ALM will close to TB4-COM to indicate an alarm signal.

- Compressor Minimum ON timer
- Compressor is disabled for heating, cooling, and dehumidification

High Pressure/Low Pressure Reset

After the HP circuit is closed, the unit does not return to normal operation until the alarm is manually reset. The unit is locked out in this manner until the unit can be serviced. For two compressor units, upon a failure of the a compressor, it will be “fail replaced” by the other compressor if available.

The alarm is reset by a short interruption of unit power, by holding down the tenant override button for more than 10 seconds, or via the Building Automation System (BAS).

Low Suction Temperature Fault Heating

1. When the suction line temperature falls below 28°F (standard range) or 6.5°F (Geothermal), the Low Suction Temperature Fault will be generated.
2. The control will attempt to recover from a low suction temperature condition by defrosting the water heat exchanger. See “[Defrost Sequence of Operation \(Heating\)](#)”.
3. If during the Defrost Sequence of Operation the suction line temperature increases by the Low Temp Protect Diff (the default is 8°F), the unit will return to normal operation.

For two compressor units, upon a failure of one compressor, it will be “fail replaced” by the other compressor if available.
4. If during the Defrost Sequence of Operation the suction line temperature does not increase by the Low Temp Protect Diff, or if the 3rd occurrence of the Low Suction Temperature Fault alarm occurs in the heating mode within a 24 hour time-frame, the compressor will remain off until the alarm is reset.

Defrost Sequence of Operation (Heating)

1. The reversing valve output is de-activated, placing the reversing valve in the cooling mode and moving warm refrigerant to the water heat exchanger.
2. Fan speed is not changed, however “Heat Stage 1” speed is used if the fan is presently off.
3. If the compressor was on at the beginning of the defrost process, then start the 60 second fixed defrost timer.
4. Wait for the defrost timer to expire.
5. If the alarm condition has cleared:
 - Return to normal operation.
6. If the alarm condition remains active:
 - For Single Compressor Units:
 - Compressor High Capacity is turned off
 - Compressor is immediately turned off, ignoring the

For Two Compressor Units:

- The compressor is immediately turned off
- The compressor without any faults will be used

If no compressors are available:

- Electric heating can be used if it is available
- Fan and pump remain available for operation
- Alarm output energizes.
- When the suction line temperature increases to 36°F (default) standard equipment (14.5°F on geothermal) the low temperature fault continues and the compressor will be locked out.

Low Suction Temperature Fault Cooling/Dehumidification

When the suction line temperature falls below 28°F, the compressor output is disabled. The fan will continue to run allowing the air coil to defrost. Once the suction line temperature increases to 8°F (default), the compressor will be enabled once the compressor minimum off time has expired. For two compressor units, the compressor experiencing the alarm will be replaced by the other compressor if available.

LED Activity	Type	Color	Description
4 Flash	Fault	Red	Compressor 1 Low Suction Temp
8 Flash	Fault	Red	Compressor 2 Low Suction Temp

Condensate Overflow

LED Activity	Type	Color	Description
7 Flash	Fault	Yellow	Condensate Overflow

The MT2300 unit controller's condensate sensor is designed to detect excessively high condensate water levels in the drain pan. When high condensate water levels are detected during cooling or dehumidification modes, the controller enters into condensate fault mode. The fan operates at fan only speed during the condensate overflow fault mode. The controller will continue to operate in heat mode.

Some faults and modes have higher priority than condensate overflow mode. See [Table 8 on page 16](#).

When the unit senses a condensate overflow fault while in cooling mode the following occurs:

1. The compressor de-energizes.
2. The alarm terminal (TB4-ALM) energizes (fault). TB4-ALM will close to TB4-COM to indicate an alarm signal.

When condensate levels return to normal, the controller will automatically return to normal operation.

Remote Reset of Automatic Lockouts

The Remote Reset feature provides the means to remotely reset automatic lockouts. There are (3) ways to accomplish a unit reset once the fault condition has been remedied:

- Using the thermostat cycle from cool or heat to off and back to heat or cool two times within 30 seconds
- Press the Room Sensor or Thermostat Timed Override/Reset Button for more than 10 seconds
- Turn the unit power off and wait until the controller has fully powered off before turning it back on.

When the cause of the fault condition has been remedied, and the unit is cycled from not requiring heating or cooling to needing heating or cooling twice within 30 seconds (accomplished by user manipulation of the Heat/Cool/ Auto/Off switch on the thermostat), an alarm reset equivalent to a tenant override button reset is generated. The intelligent reset counter and the 24 hour timer are cleared when this type of alarm reset is generated.

NOTICE

This feature only applies to thermostat controlled systems.

For room sensor controlled units, pressing the "Override" or "Reset" button for more than 10 seconds will apply a ground signal to the Room Temperature Sensor connection at TB2 pin 4, RS clearing the lockout alarm once the cause of the fault condition has been remedied.

A unit power cycle can also be used to clear an automatic lockout if the conditions causing the fault have been remedied.

Fan Operation During Most Modes, Faults and Shutdowns

The MT2300 unit controller allows fan operation during most modes, faults and shutdowns to facilitate maximum space comfort and control. However, the fan does not operate during brownout or emergency shutdown condition. During most modes, faults, or shutdowns the fan will operate normally.

Operation with the High Speed Configuration Switch

The MT2300 unit controller includes a high-speed configuration switch to enter service/test mode for troubleshooting. See [Figure 2 on page 6](#) for SW1 location.

NOTICE

This switch is intended for factory unit testing and should only be used by trained service technicians as several timing functions are reduced to speed system check out.

- Disconnect power to the unit when changing the position of the SW1 configuration switch.
- The high speed switch should only be used for a short period of time for testing of the unit's operation by a trained service technician. The switch must be set to off for normal unit operation.
- If the switch is left on after system check out, the unit may be damaged.

Troubleshooting

MT2300 Unit Controller LED Faults

Microcontroller Not Programmed or Hardware Failure

LED Activity	Type	Color	Description
Steady ON	Fault	Red	Hardware Failure
Steady ON	Fault	Yellow	MCU Not Programmed

- Replace the controller.

Invalid Configuration

LED Activity	Type	Color	Description
1 Flash	Fault	R-Y-G	Invalid Configuration

- Verify configuration switch settings on both the MT2300 main board and MT2310 I/O expansion board.
- Configuration switch setting must be verified using the configuration switch setting outlined in this document.
- MT2300 main board and MT2310 I/O expansion board software must be compatible.

Incompatible Software

LED Activity	Type	Color	Description
2 Flash	Fault	R-Y-G	Incompatible Software

- Replace the controller.

I/O Expansion Board Communication Fail

LED Activity	Type	Color	Description
1 Flash	Fault	R-Y	I/O Exp Board Communications Fail

- Verify connection of 5 wire cable between H3 on the MT2300 main board and H3 on the MT2310 I/O expansion board is fully engaged in the connector.
- Confirm the low voltage supply is between 19-32VAC at the H1 terminal of the MT2310 I/O expansion board.
- Replace MT2310 I/O expansion board.

Service Test Mode Enabled

LED Activity	Type	Color	Description
1 Flash	Mode	G-Y	Service/Test Mode Active

- MT2300 configuration switch SW1 is ON for test mode operation.

A2L Alarm – Refrigerant Leak

LED Activity	Type	Color	Description
Rapid Flash	Fault	Red	A2L Mitigation – Refrigerant Leak

- MT6210 mitigation controller has detected a A2L refrigerant leak.
- If no MT6210 mitigation controller is present, 5VDC is detected at H1-5 but 12VDC is not detected at H1-3 12V_ A2L input. Check connection at this terminal.
- Compressor and electric heat will be disabled and the fan

will be forced to high speed during this alarm and for a minimum of 5 minutes after it has been resolved.

Compressor High Pressure

LED Activity	Type	Color	Description
1 Flash	Fault	Red	Compressor 1 High Pressure
5 Flash	Fault	Red	Compressor 2 High Pressure

Compressor 1

- Verify high pressure switch is connected to terminal H7, pins 3 and 4 on the MT2300 main board.
- Check for continuity of the high pressure switch.

Compressor 2

- Verify high pressure switch is connected to terminal H2, pins 5 and 6 on the MT2310 I/O expansion board.
- Check for continuity of the high pressure switch.

Both Compressors

If the high pressure fault resets when power is recycled:

- Check water flow (cooling operation)
- Check airflow (heating operation)
- Entering water and air temperatures should be within the operating limits.

Compressor Low Pressure

LED Activity	Type	Color	Description
2 Flash	Fault	Red	Compressor 1 Low Pressure
6 Flash	Fault	Red	Compressor 2 Low Pressure

Compressor 1

- Verify low pressure switch is connected to terminal H7, pins 1 and 2 on the MT2300 main board.
- Check for continuity of the low pressure switch.

Compressor 2

- Verify low pressure switch is connected to terminal H2, pins 3 and 4 on the MT2310 I/O expansion board.
- Check for continuity of the low pressure switch.

Both Compressors

- If low pressure switch is confirmed to not have continuity, unit may be low on charge.

Compressor Suction Temp Sensor Failure

LED Activity	Type	Color	Description
3 Flash	Fault	Red	Compressor 1 Suction Temp Sensor Out of Range
7 Flash	Fault	Yellow	Compressor 2 Suction Temp Sensor Out of Range

Compressor 1

- Check connection of low suction temperature sensor 1 on terminal H2, pins 5 and 6 on the MT2300 main board.
- Check resistance of low suction temperature sensor 1. All sensors are 10k ohm NTC Type II thermistor at 77°F.

Compressor 2

- Check connection of low suction temperature sensor 2 on

terminal H2, pins 1 and 2 on the MT2310 I/O expansion board.

- Check resistance of low suction temperature sensor 2. All sensors are 10k ohm NTC Type II thermistor at 77°F.

Room Temp Sensor Failure (Room Sensor Control Only)

LED Activity	Type	Color	Description
8 Flash	Fault	Yellow	Space Temp Sensor Out of Range

Room sensor control units only (MT2300 configuration switch SW6 is ON).

- If unit does not have a space or return air temperature sensor, check SW6.
- Check connection of space temperature sensor on MT2300 terminal TB2, pins 4 (RM) and 5 (GND).
- Check resistance of room sensor. All sensors are 10k ohm NTC Type II thermistor at 77°F.

Return Air Sensor Failure (HGRH Units Only)

LED Activity	Type	Color	Description
9 Flash	Fault	Yellow	Return Air Temp Sensor Out of Range

Hot Gas Reheat is enabled (MT2310 configuration switch SW7 is ON).

- Check connection of return air temperature sensor on MT2310 terminal H4, pins 3 (GND) and 4 (RAT).
- If unit does not have HGRH, check MT2310 I/O expansion board SW7.
- Check resistance of return air sensor. All sensors are 10k ohm NTC Type II thermistor at 77°F.

Compressor Low Suction Temp

LED Activity	Type	Color	Description
4 Flash	Fault	Red	Compressor 1 Low Suction Temp
8 Flash	Fault	Red	Compressor 2 Low Suction Temp

- Check water flow (heating operation).
- Check airflow (cooling operation).
- Entering water and air temperatures should be within the operating limits.

A2L Alarm – Control Board Without Power

LED Activity	Type	Color	Description
9 Flash	Fault	Red	A2L Mitigation – Control Board Without Power

- MT6210 mitigation controller is not powered up. Check power connection to the MT6210 mitigation controller.
- If no MT6210 mitigation controller is present, 5VDC is not detected at H1-5 and 12VDC is not detected at H1-3 12V_A2L input. Check connection at this terminal.

A2L Error – Refrigerant Sensor Failure

LED Activity	Type	Color	Description
Rapid Flash	Mode	Yellow	A2L Mitigation – Refrigerant Sensor Out of Range

- MT6210 mitigation controller has detected a A2L refrigerant sensor malfunction and one or more of the sensors need to be replaced.
- If the MT6210 does not indicated a A2L refrigerant sensor malfunction or no MT6210 mitigation controller is present, 5VDC is not detected at H1-5 but 12VDC is detected at H1-3 12V_A2L input. Check connection at this terminal.
- The fan will be forced to run at High Speed in this condition.

Low Voltage Brownout

LED Activity	Type	Color	Description
1 Flash	Fault	Yellow	Compressor Low Voltage Brownout

- Confirm the low voltage supply is between 19-32VAC at the H1 terminal of the MT2300 main board. If the low voltage supply is out of range, verify the unit supply voltage matches the nameplate voltage and the correct transformer primary wire has been selected.

Freeze Fault Detect

LED Activity	Type	Color	Description
2 Flash	Fault	Yellow	Freeze Fault Detect (FFD)

- Low leaving water temperature (below 35°F standard range or 13.5°F extended range)

Control Temp Sensor Failure

LED Activity	Type	Color	Description
3 Flash	Fault	Yellow	Control Temp Sensor Out of Range

- Room sensor control units only (MT2300 configuration switch SW6 is ON).
- Check connection of space temperature sensor on MT2300 terminal TB2 pins 4 (RM) and 5 (GND) and return air temperature sensor on MT2310 terminal H4 pins 3 (GND) and 4 (RAT).
- Check resistance of space sensor and return air sensor. All sensors are 10k ohm NTC Type II thermistor at 77°F.

Entering Water Temp Sensor Failure

LED Activity	Type	Color	Description
4 Flash	Fault	Yellow	Entering Water Temp Sensor Out of Range

- Boilerless Electric Heat is enabled (MT2310 configuration switch SW5 is OFF and SW6 is ON), or
- Hydronic Heating is enabled (MT2310 configuration switch SW5 is ON and SW6 is ON), or
- Waterside Economizer is enabled (MT2310 configuration switch SW8 is ON).
- Check connection of entering water temperature sensor on MT2310 I/O expansion board terminal H4 pins 1 and 2.
- Check resistance of the entering water temperature sensor. All sensors are 10k ohm NTC Type II thermistor at 77°F.

Leaving Water Temperature Sensor Failure

LED Activity	Type	Color	Description
5 Flash	Fault	Yellow	Leaving Water Temp Sensor Out of Range

- Freeze Fault Detect enabled (MT2300 configuration switch SW4 is ON).
- Check connection of leaving water temperature sensor on MT2300 terminal H2 pins 1 (LWT) and 2 (GND).
- Check resistance of leaving water temperature sensor. All sensors are 10k ohm NTC Type II thermistor at 77°F.

Relative Humidity Sensor Failure

LED Activity	Type	Color	Description
6 Flash	Fault	Yellow	Relative Humidity Sensor Out of Range

- Relative Humidity Sensor Failure alarm has been enabled via network communications and the sensor is reporting out of range.
- Check connection of relative humidity sensor on MT2310 terminal TB1 pins 1 (REF) and 2 (RH).
- Check that relative humidity sensor has power.
- Check voltage output from relative humidity sensor (0-10VDC, 0-100% RH)

Condensate Overflow

LED Activity	Type	Color	Description
7 Flash	Fault	Yellow	Condensate Overflow

- Poor condensate drain.
- Check the resistance to ground on condensate wire. This should be open if there is no water in the pan.

Emergency Shutdown

LED Activity	Type	Color	Description
Rapid Flash	Mode	Green	Emergency Shutdown

- Verify the E terminal is not connected to common. Remove wire, if connected, and LED should change to solid green only (Occ, Bypass, Standby modes).

Occupied, Bypass, Standby Modes: Heating/Cooling/Fan Only/Dehumidification

LED Activity	Type	Color	Description
1 Flash	Mode	Green	No Call for Heating / Cooling / Dehumidification
2 Flash	Mode	Green	Call for Cooling
3 Flash	Mode	Green	Call for Heating
4 Flash	Mode	Green	Call for Fan Only
6 Flash	Mode	Green	Call for Dehumidification

- Unit is operating normally. It may currently have a control signal or ready to operate when a control signal is active.

Unoccupied Mode

LED Activity	Type	Color	Description
5 Flash	Mode	Green	Unoccupied Mode Active

- Terminal U on main control board is connected to common from external source or commanded by network.

Low Entering Water Temperature (Heating) (No Display On Boilerless Electric Heat)

LED Activity	Type	Color	Description
7 Flash	Mode	Green	Low Entering Water Temp

- Verify entering water temperature is greater than set point.

HGRH Low Return Air Temp Cutout

LED Activity	Type	Color	Description
8 Flash	Mode	Green	HGRH Low Return Air Temp Cutout

- Unit is in the dehumidification mode and the return air temperature is below 68°F.

Waterside Economizer Low Temp Cutout (WSE Control & Call for Cooling)

LED Activity	Type	Color	Description
9 Flash	Mode	Green	WSE Low Temp Cutout

- Entering water temperature is below 45°F.

A2L Detection and Mitigation

A2L Refrigerant Detection System

Daikin Applied WSHP units that have above 4 lbs (64 oz) of refrigerant per circuit have a factory installed refrigerant detection system consisting of the following parts:

- Refrigerant Sensor(s) (quantity 2)
Part Number: 910419801
- A2L Refrigerant Detection Controller (quantity 1)
Part Number: 910419225

The sensors are wired in a daisy chain configuration and terminated at the mitigation board. The A2L Main Control board connects to the MicroTech controller and signal alarms based on this system status.

Alarms

- Refrigerant Leak:
 - The Refrigerant Detection Controller will trigger a leak alarm when at least 1 sensor detects a refrigerant concentration above 15% of the refrigerant Lower Flammability Level (LFL).
 - Upon detection of a leak, the mitigation board ALM and CUST relays are energized and the alarm is indicated to the MicroTech unit controller.
- Refrigerant Sensor Fault:
 - The Refrigerant Detection Controller will trigger a fault alarm when any connected sensor is determined to be faulty (self-test failure, loss of communications, etc.).
 - Upon detection of a sensor fault, the fault is indicated to the MicroTech unit controller.

A2L Leak Mitigation

The MicroTech controller performs the following mitigation sequences to maintain safe operation in the event of an alarm condition:

Refrigerant Leak Detected

Upon notification from the refrigerant detection system that a leak was detected, the MicroTech controller will disable compressor operation immediately, turn the fan on at its highest speed, disable electric heat, and indicate a refrigerant leak alarm.

- The Refrigerant Detection Controller continues to monitor the refrigerant sensors in the system and notifies the MicroTech unit controller when no refrigerant has been detected for five minutes, allowing the unit to resume normal operation.

Sensor Fault Detected

A fault can be caused by a leak sensor malfunctioning or being disconnected or an A2L board malfunction.

Upon notification from the refrigerant detection system that a sensor fault was detected, the MicroTech controller will allow normal operation except that it will turn the fan on at its highest speed, to maintain adequate airflow through the system to dilute any of the leaked refrigerant, and indicate a sensor fault alarm.

A2L Refrigerant Detection Sensor and Board Service

- The sensors are not considered “Limited Life Sensors” and therefore, under normal operation, are not expected to be replaced within the life expectancy of the unit.
- The sensors have self-reporting diagnostics, which are monitored by the mitigation board. In the event that the sensor fails, the mitigation board will trigger a “Fault” alarm.
- There are no servicing nor maintenance requirements for the sensor(s) and board.

A2L Refrigerant Detection Sensor and Board Troubleshooting and Diagnostics

At power up, the Refrigerant Detection Controller display shows what sensors are detected (SX = 1, sensor X is active and communicating), and what sensors are not detected (SX = 0, sensor X is not communicating or inactive). Where X, is the sensor number (from 1 to 8).

By pressing and holding the push button for:

- *Less than 2 seconds*
The Refrigerant Detection Controller display shows the last 10 sensor faults (can be loss of communication or faulted state reported by a specific sensor). General configuration fault (Flt CFG) is also shown when the expected number of sensors does not match the number of sensors detected online.
- *More than 2 seconds and less than 5 seconds*
The display shows sensor(s) status info:
 - The current LFL level.
 - Loss of communication or faulted state reported by a specific sensor.
- *More than 5 seconds and less than 10 seconds*
The Refrigerant Detection Controller starts a mitigation test. The board will go into alarm mode and the MicroTech controller will begin the mitigation sequence. The mitigation test will last approximately 5 minutes.
- *More than 10 seconds*
The display shows all the GID values supported by the sensor board as shown in [Table 11 on page 25](#).

Table 11: GID Descriptions

GID id	Name	Min Limit	Max Limit	Default	Description
1	Number of Sensors	1	8	2	Number of sensors configured.
2	LFL Fault Threshold	1	10000	500	LFL Threshold for setting a fault.
3	LFL ALARM Threshold	1	1000	150	LFL Threshold setting an alarm. 150 = 15%
4	USB Baud Rate	19200	115200	115200	Baud rate used for communicating with an external terminal.
5	Modbus Client Baud	19200	38400	38400	Baud rate used for communicating with the sensors.
6	Modbus Server Baud	9600	115200	19200	Baud rate used for communicating with an external controller.
7	Test Mitigation Time	10	300	300	Test Mitigation time in seconds.
8	Sensor Warm Up Time	5	180	30	Sensor warm up time during power up in seconds.
9	Mitigation Time	120	1200	300	Mitigation time in seconds after LFL alarm has disappear.
10	Num of Sensors Online	1	8	1	Number of sensors detected online.
11	A2L State	0	5	0	A2L System State. Value = 1, A2L State is "run"
12	Last Fault	0	2	0	Recent Fault, Fault_Codes_e
13	Modbus Server Address	1	10	9	A2L Modbus Address used in Modbus Server Network
14	Sensor Addr Min	45	50	48	Minimum address assigned to a recent discovered sensor.
15	EETbl Save Now	0	1	0	Command to save data on non volatile memory.
16	System Test	0	1	0	System Test Mitigation Request.
17	Display LFL	0	1	0	Display LFL Levels
18	EETbl LoadDefaults	0	1	0	Load Defaults values for those non volatile parameters.
19	EETbl Rev	1	1	1	EE Table Revision
20	Sensor 1 Address	GID14	GID14 + 7	0	Sensor 1 Address
21	Sensor 1 Level	0	65535	0	Sensor 1 LFL reported value. For instance value = 200, then LFL is 20%
22	Sensor 1 State	1	65535	0	Sensor 1 current state. Value = 2, then state is "run"
23	Sensor 1 Faults	0	65535	0	Sensor 1 internal faults reported. For instance value = 0, then no faults.
24	Sensor 1 Temperature	-400	940	0	Sensor 1 Temperature reported value. For instance value = 250, then Temp = 25 C
25	Sensor 1 Humidity	0	1000	0	Sensor 1 Humidity reported value. For instance value = 400, then Humidity = 40%
26	Sensor 1 Pressure	0	4000	0	Sensor 1 Pressure reported value. Not available for now.
27	Sensor 2 Address	GID14	GID14 + 7	0	Sensor 2 Address
28	Sensor 2 Level	0	65535	0	Sensor 2 LFL reported value. For instance value = 200, then LFL is 20%
29	Sensor 2 State	1	65535	0	Sensor 2 current state. Value = 2, then state is "run"
30	Sensor 2 Faults	0	65535	0	Sensor 2 internal faults reported. For instance value = 0, then no faults.
31	Sensor 2 Temperature	-400	940	0	Sensor 2 Temperature reported value. For instance value = 250, then Temp = 25 C
32	Sensor 2 Humidity	0	1000	0	Sensor 2 Humidity reported value. For instance value = 400, then Humidity = 40%
33	Sensor 2 Pressure	0	4000	0	Sensor 2 Pressure reported value. Not available for now.
34	Sensor 3 Address	GID14	GID14 + 7	0	Sensor 3 Address
35	Sensor 3 Level	0	65535	0	Sensor 3 LFL reported value. For instance value = 200, then LFL is 20%
36	Sensor 3 State	1	65535	0	Sensor 3 current state. Value = 2, then state is "run"
37	Sensor 3 Faults	0	65535	0	Sensor 3 internal faults reported. For instance value = 0, then no faults.
38	Sensor 3 Temperature	-400	940	0	Sensor 3 Temperature reported value. For instance value = 250, then Temp = 25 C
39	Sensor 3 Humidity	0	1000	0	Sensor 3 Humidity reported value. For instance value = 400, then Humidity = 40%
40	Sensor 3 Pressure	0	4000	0	Sensor 3 Pressure reported value. Not available for now.
41	Sensor 4 Address	GID14	GID14 + 7	0	Sensor 4 Address
42	Sensor 4 Level	0	65535	0	Sensor 4 LFL reported value. For instance value = 200, then LFL is 20%

GID id	Name	Min Limit	Max Limit	Default	Description
43	Sensor 4 State	1	65535	0	Sensor 4 current state. Value = 2, then state is "run"
44	Sensor 4 Faults	0	65535	0	Sensor 4 internal faults reported. For instance value = 0, then no faults.
45	Sensor 4 Temperature	-400	940	0	Sensor 4 Temperature reported value. For instance value = 250, then Temp = 25 C
46	Sensor 4 Humidity	0	1000	0	Sensor 4 Humidity reported value. For instance value = 400, then Humidity = 40%
47	Sensor 4 Pressure	0	4000	0	Sensor 4 Pressure reported value. Not available for now.
48	Sensor 5 Address	GID14	GID14 + 7	0	Sensor 5 Address
49	Sensor 5 Level	0	65535	0	Sensor 5 LFL reported value. For instance value = 200, then LFL is 20%
50	Sensor 5 State	1	65535	0	Sensor 5 current state. Value = 2, then state is "run"
51	Sensor 5 Faults	0	65535	0	Sensor 5 internal faults reported. For instance value = 0, then no faults.
52	Sensor 5 Temperature	-400	940	0	Sensor 5 Temperature reported value. For instance value = 250, then Temp = 25 C
53	Sensor 5 Humidity	0	1000	0	Sensor 5 Humidity reported value. For instance value = 400, then Humidity = 40%
54	Sensor 5 Pressure	0	4000	0	Sensor 5 Pressure reported value. Not available for now.
55	Sensor 6 Address	GID14	GID14 + 7	0	Sensor 6 Address
56	Sensor 6 Level	0	65535	0	Sensor 6 LFL reported value. For instance value = 200, then LFL is 20%
57	Sensor 6 State	1	65535	0	Sensor 6 current state. Value = 2, then state is "run"
58	Sensor 6 Faults	0	65535	0	Sensor 6 internal faults reported. For instance value = 0, then no faults.
59	Sensor 6 Temperature	-400	940	0	Sensor 6 Temperature reported value. For instance value = 250, then Temp = 25 C
60	Sensor 6 Humidity	0	1000	0	Sensor 6 Humidity reported value. For instance value = 400, then Humidity = 40%
61	Sensor 6 Pressure	0	4000	0	Sensor 6 Pressure reported value. Not available for now.
62	Sensor 7 Address	GID14	GID14 + 7	0	Sensor 7 Address
63	Sensor 7 Level	0	65535	0	Sensor 7 LFL reported value. For instance value = 200, then LFL is 20%
64	Sensor 7 State	1	65535	0	Sensor 7 current state. Value = 2, then state is "run"
65	Sensor 7 Faults	0	65535	0	Sensor 7 internal faults reported. For instance value = 0, then no faults.
66	Sensor 7 Temperature	-400	940	0	Sensor 7 Temperature reported value. For instance value = 250, then Temp = 25 C
67	Sensor 7 Humidity	0	1000	0	Sensor 7 Humidity reported value. For instance value = 400, then Humidity = 40%
68	Sensor 7 Pressure	0	4000	0	Sensor 7 Pressure reported value. Not available for now.
69	Sensor 8 Address	GID14	GID14 + 7	0	Sensor 8 Address
70	Sensor 8 Level	0	65535	0	Sensor 8 LFL reported value. For instance value = 200, then LFL is 20%
71	Sensor 8 State	1	65535	0	Sensor 8 current state. Value = 2, then state is "run"
72	Sensor 8 Faults	0	65535	0	Sensor 8 internal faults reported. For instance value = 0, then no faults.
73	Sensor 8 Temperature	-400	940	0	Sensor 8 Temperature reported value. For instance value = 250, then Temp = 25 C
74	Sensor 8 Humidity	0	1000	0	Sensor 8 Humidity reported value. For instance value = 400, then Humidity = 40%
75	Sensor 8 Pressure	0	4000	0	Sensor 8 Pressure reported value. Not available for now.
76	DF Saving Time	15	120	15	Data Flash saving time in minutes. How frequent data is saved on non volatile memory.
77	Nominated Sensor Addr	48	55	55	Sensor address to be reset to the default value
78	Sensor Reset Command	0	1	0	Command to invoke sensor function reset, value = 1 then this command is invoked.
79	Sen Func Reset Result	0	1	0	Final result of the sensor reset function operation. Value = 0, the operation was successful.

COMPLETE HVAC SYSTEM SOLUTIONS

SELF-CONTAINED | ROOFTOPS | COILS | CONDENSING UNITS
AIR HANDLERS | WATER-COOLED CHILLERS | AIR-COOLED CHILLERS
MODULAR CENTRAL PLANTS | CONNECTED BUILDING CONTROLS
UNIT HEATERS | FAN COILS | AIR PURIFIERS | WATER SOURCE HEAT PUMPS
VARIABLE AIR VOLUME UNITS | UNIT VENTILATORS



13600 INDUSTRIAL PARK BLVD. | MINNEAPOLIS, MN 55441
1-800-432-1342 | 763-553-5330

LEARN MORE AT
DAIKINAPPLIED.COM

PART NUMBER: OM1364-4

© 2026 DAIKIN APPLIED | (800) 432.1342 | WWW.DAIKINAPPLIED.COM