

MICROTECH[®] 2300 UNIT CONTROLLER

WITH MICROTECH 2310 I/O EXPANSION BOARD FOR
SINGLE COMPRESSOR WATER SOURCE HEAT PUMPS

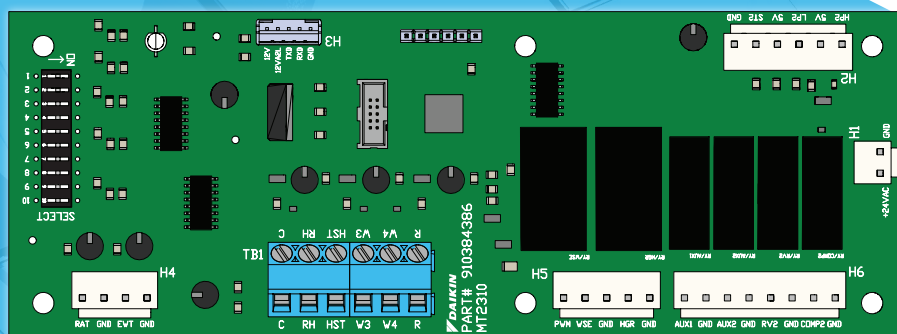
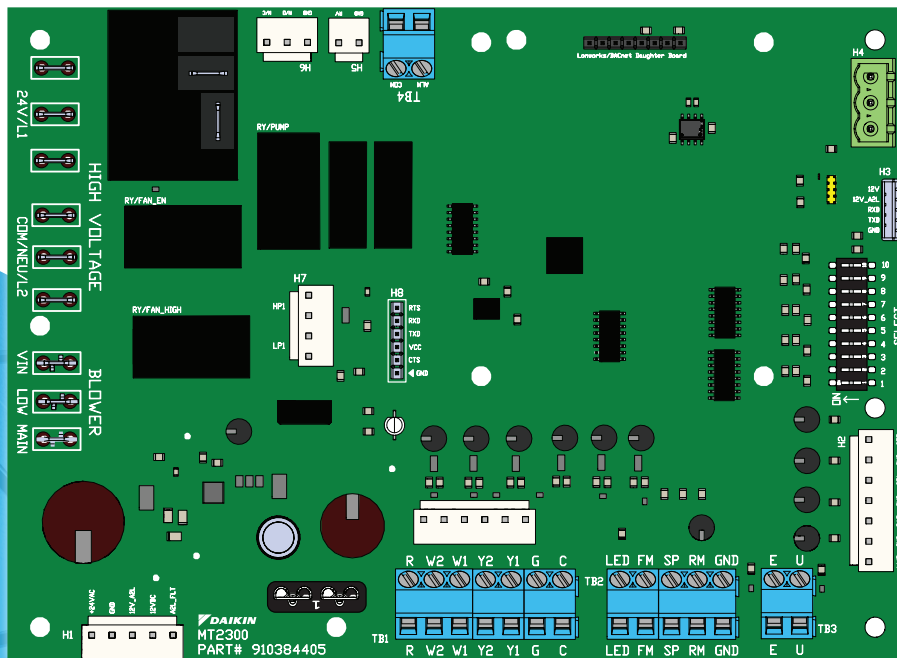

- FOR MODELS SCH, SMH, SSH

Safety Information	3	Electric Heat Controls	22
Hazard Identification	3	Supplemental Electric Heat Control	22
Safety Considerations	3	Boilerless Heat Control	22
Introduction	3	Heating Source Selection	23
Connections and Terminals	4	Hydronic Heat	23
Unit Controller and Control Modules I/O Descriptions	4	Fan Speed Selection	24
MT2300 Unit Controller & MT2310 I/O Board		Unit Options	25
Connections	5	Waterside Economizer	25
Replacing Unit Controller	6	Dehumidification	26
Configuration DIP Switches	6	Simplified Dehumidification	26
Functionality	8	Hot Gas Reheat Smart Dehumidification	26
Operating Modes	8	Humidistat Controlled Dehumidification	29
Safety Inputs (HPS, LPS, SLTS, COS)	8	Dehumidification Only	30
Control Outputs	9	Analog Humidity Sensor Input	30
LED Indicators	9	Controls	31
Sequence Of Operation	10	MT2300 Controller with an Optional BACnet®	
Unit Status	12	Communication Module	31
Remote Shutdown	12		
Thermostat Inputs (G, Y1, Y2, W1, W2, W3, and W4)	12		
Fault Modes	14		
Brownout	14		
High / Low Pressure Faults (HP/LP)	14		
Low Suction Temperature Fault Heating	14		
Low Suction Temperature Fault Cooling /			
Dehumidification	15		
Condensate Overflow	15		
Fan Operation During Most Modes, Faults and			
Shutdowns	15		
Faults and Modes	16		
Troubleshooting	18		
MT2300 Unit Controller LED Faults	18		
Troubleshooting the Water Source Heat Pump Unit	20		
Start-Up	21		
Operation	21		
Thermostat Inputs	21		

©2024 Daikin Applied, Minneapolis, MN. All rights reserved throughout the world. This document contains the most current product information as of this printing. Daikin Applied Americas Inc. has the right to change the information, design, and construction of the product represented within the document without prior notice. For the most up-to-date product information, please go to www.DaikinApplied.com.

™@ MicroTech, SiteLine, SmartSource, and Daikin Applied are trademarks or registered trademarks of Daikin Applied Americas Inc. The following are trademarks or registered trademarks of their respective companies: BACnet from American Society of Heating, Refrigerating and Air-Conditioning Engineers, Inc.; Echelon, LonWorks, LonMark, and LonTalk from Echelon Corporation; Modbus from Schneider Electric; and Windows from Microsoft Corporation.

Safety Information

Hazard Identification

DANGER

Danger indicates a hazardous situation, which will result in death or serious injury if not avoided.

WARNING

Warning indicates a potentially hazardous situations, which can result in property damage, personal injury, or death if not avoided.

CAUTION

Caution indicates a potentially hazardous situations, which can result in minor injury or equipment damage if not avoided.

NOTICE

Notice indicates practices not related to physical injury.

NOTE: Indicates important details or clarifying statements for information presented in Figures or Tables.

Safety Considerations

This manual provides installation, operation, and maintenance information for a Daikin Applied MicroTech 2300 Unit Controller.

NOTICE

Installation and maintenance are to be performed only by licensed, if required by local codes and regulations, or qualified personnel who are familiar with local codes and regulations and are experienced with this type of equipment.

DANGER

LOCKOUT/TAGOUT all power sources prior to service, pressurizing, depressurizing, or powering down the unit. Failure to follow this warning exactly can result in serious injury or death. Disconnect electrical power before servicing the equipment. More than one disconnect may be required to deenergize the unit. Be sure to read and understand the installation, operation, and service instructions within this manual.

WARNING

Electric shock hazard. Improper handling of this equipment can cause personal injury or equipment damage. This equipment must be properly grounded. Connections to and service of the MicroTech control panel must be performed only by personnel that are knowledgeable in the operation of the equipment being controlled.

CAUTION

Static sensitive components. A static discharge while handling electronic circuit boards can cause damage to the components. Discharge any static electrical charge by touching the bare metal inside the control panel before performing any service work. Never unplug any cables, circuit board terminal blocks, or power plugs while power is applied to the panel.

Introduction

This installation and operation manual covers the MT2300 unit controller and MT2310 I/O expansion board for Daikin Water Source Heat Pumps. For information on BACnet® communication modules see:

- IM 955 - MicroTech III Wall Sensor For use with Microtech III Unit Controller
- IM 1363 - MicroTech MT2300 Water Source Heat Pump Unit Controller BACnet MS/TP Network Integration
- ED 19129 - MicroTech MT2300 Water Source Heat Pump Unit Controller BACnet Protocol Information

Connections and Terminals

Unit Controller and Control Modules I/O Descriptions

Table 1: MicroTech 2300 unit controller connector and terminal descriptions

Connector	I/O	Type	Signal	Description
H1-1	24 VAC	Power	VAC	Control Power Voltage
H1-2	GND	Power	Ground	Control Power Common
H1-3	12V A2L	Input	VDC	A2L Sense Voltage
H1-4	12 VDC	Output	VDC	A2L Mitigation Voltage
H1-5	A2L FLT	Input	Digital	A2L Fault Alarm
H2-1	LWT	Input	Analog	Leaving Water Temperature
H2-2	GND	REF	Common	
H2-3	DAT	Input	Analog	Discharge Air Temperature
H2-4	GND	REF	Common	
H2-5	ST1	Input	Analog	Comp1 Suction Temperature
H2-6	GND	REF	Common	
H2-7	COF	Input	Analog	Condensate Overflow
H3-1	12 VDC	Output	VDC	Base/Expansion Board Interface
H3-2	12V A2L	Output	VDC	
H3-3	RXD	COM	UART	
H3-4	TXD	COM	UART	
H3-5	GND	COM	UART	
H4-1	B(+)	COM	N/A	Future Use
H4-2	A(-)	COM	N/A	
H4-3	GND	COM	N/A	
H5-1	GND	REF	Common	Comp1 Reversing Valve
H5-2	RV	Output	24 VAC	
H6-1	N/C	Output	24 VAC	Pump Request - Normally Closed Terminal for Normally Open Valves
H6-2	N/O	Output	24 VAC	Pump Request - Normally Open Terminal for Normally Closed Valves
H6-3	GND	REF	Common	Pump Request
H7-1,2	HP1	Input	Digital	Comp1 High Pressure
H7-3,4	LP1	Input	Digital	Comp1 Low Pressure
TB1-1	R	Output	24 VAC	Thermostat 24 VAC Power
TB1-2	W2	Input	24 VAC	Thermostat Heat Stage 2
TB1-3	W1	Input	24 VAC	Thermostat Heat Stage 1
TB1-4	Y2	Input	24 VAC	Thermostat Cool Stage 2
TB1-5	Y1	Input	24 VAC	Thermostat Cool Stage 1
TB1-6	G	Input	24 VAC	Thermostat Fan
TB1-7	C	REF	Common	Thermostat Common
TB2-1	LED	Output	5 VDC	Room Sensor LED
TB2-2	FM	Input	Analog	Room Sensor Fan/Mode
TB2-3	SP	Input	Analog	Room Sensor Setpoint Adjust
TB2-4	RM	Input	Analog	Room Sensor Air Temp / Tennant Override
TB2-5	GND	REF	Common	Room Sensor
TB3-1	E	Input	Digital	Emergency Shutdown
TB3-2	U	Input	Digital	Unoccupied Sensor
TB4-1,2	ALM	Output	Digital	Alarm Output - Contact Closure
BLOWER	VIN	Input	VAC	Blower Motor Voltage
BLOWER	LOW	Output	VIN	Blower Motor Low Speed

Connector	I/O	Type	Signal	Description
BLOWER	MAIN	Output	VIN	Blower Motor High Speed or ECM
LIVE (Relay)	Comp1	Output	L1/24V	Compressor Stage 1
LIVE x 3	24V/L1	Input	VAC	COMP1 Line1 Control Voltage
LIVE x 3	COM/NEU/L2	Input	VAC	COMP1 Line2 Control Voltage
Daughter Board	BACnet	COM	SPI	BACnet MS/TP Only

Table 2: MT2310 I/O board connectors and terminals

Connector	I/O	Type	Signal	Description
H1-1	GND	Power	Ground	Control Power Common
H1-2	24 VAC	Power	VAC	Control Power Voltage
H2-1	GND	REF	Common	Comp2 Suction Temperature
H2-2	ST2	Input	Analog	
H2-3,4	LP2	Input	Digital	Comp2 Low Pressure
H2-5,6	HP2	Input	Digital	Comp2 High Pressure
H3-1	12 VDC	Input	VDC	Base/Expansion Interface
H3-2	12V A2L	Input	VDC	
H3-3	TXD	COM	UART	
H3-4	RXD	COM	UART	
H3-5	GND	REF	Common	
H4-1	GND	REF	Common	Entering Water Temperature
H4-2	EWT	Input	Analog	
H4-3	GND	REF	Common	Return Air Temperature
H4-4	RAT	Input	Analog	
H5-1	GND	REF	Common	Hot Gas Reheat Valve
H5-2	HGR	Output	24 VAC	
H5-3	GND	REF	Common	Waterside Economizer Valve
H5-4	WSE	Output	24 VAC	
H5-5	PWM	Output	PWM	Variable Speed Blower Motor
H6-1	GND	REF	Common	Compressor Stage 2
H6-2	COMP2	Output	24 VAC	
H6-3	GND	REF	Common	Comp2 Reversing Valve
H6-4	RV2	Output	24 VAC	
H6-5	GND	REF	Common	Auxiliary Heat 2
H6-6	AUX2	Output	24 VAC	
H6-7	GND	REF	Common	Auxiliary Heat 1 / Hydronic Heat
H6-8	AUX1	Output	24 VAC	
TB1-1	C	REF	Common	Input Common
TB1-2	RH	Input	Analog	Space Relative Humidity
TB1-3	HST	Input	24VAC	Humidistat
TB1-4	W3	Input	24VAC	Thermostat - Stage 3 Heat
TB1-5	W4	Input	24VAC	Thermostat - Stage 4 Heat or Stage 3 Cool
TB1-6	R	Output	24 VAC	Thermostat - 24 VAC Power

MT2300 Unit Controller & MT2310 I/O Board Connections

Figure 1: MT2300 and MT2310 Connections

NOTE: Refer to Table 1 on page 4 for MT2300 controller terminal descriptions and Table 2 on page 4 for MT2310 I/O terminal descriptions

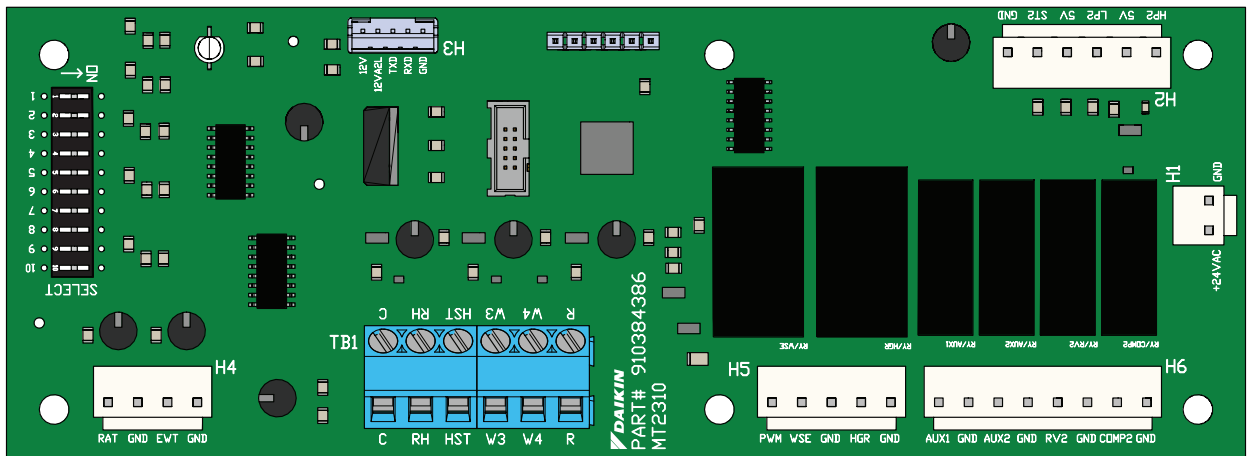
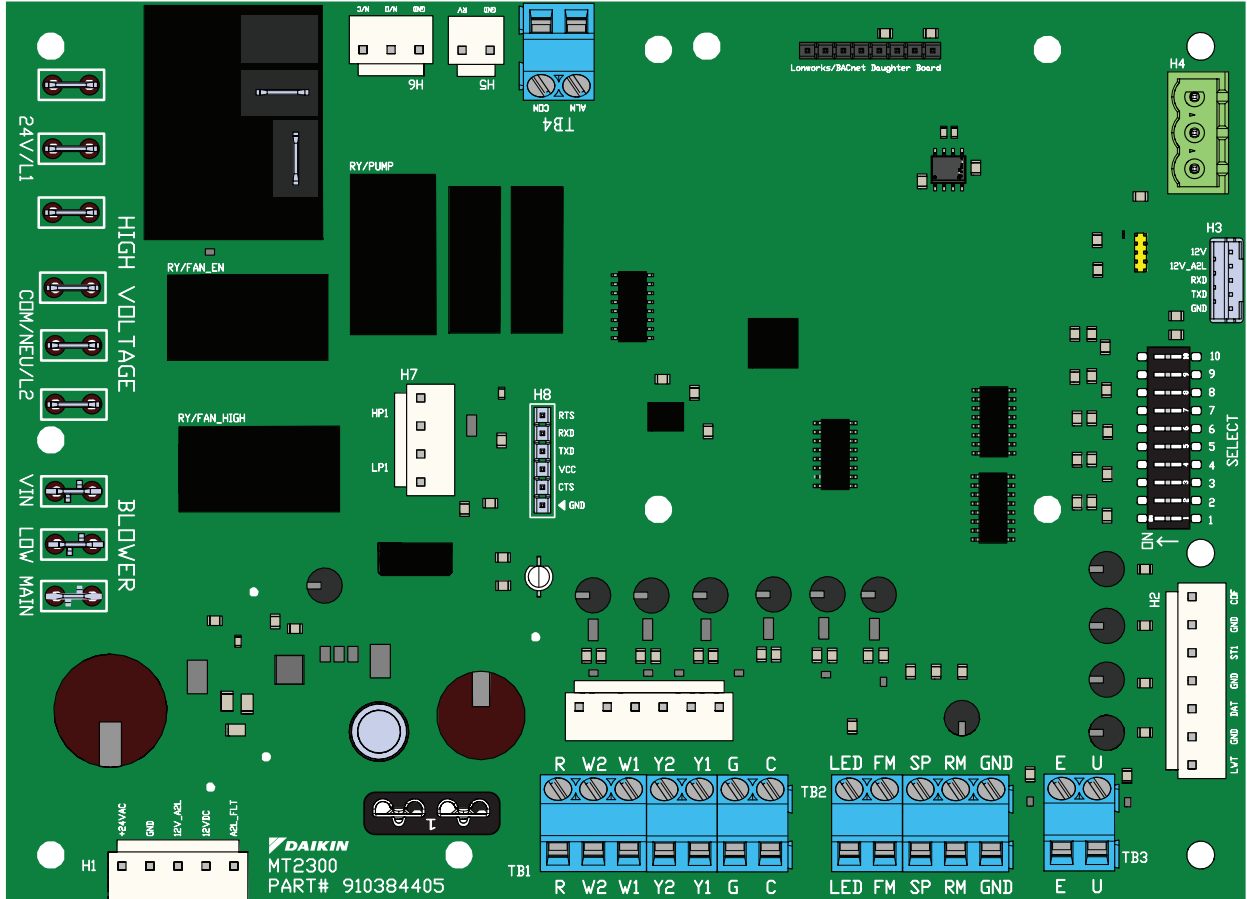

Replacing Unit Controller

1. Connect wrist strap to unit.
2. Remove faulty board and place on static protected surface.
3. Remove replacement unit controller from static protection bag.

NOTICE

Hold circuit board by edges to avoid static damage of circuit board components.

4. Holding unit controller in grounded hand, install controller in unit.
5. Insert faulty board in empty static bag for return.

Configuration DIP Switches

Figure 2: Location of configuration DIP Switches on the MT2300 Unit Controller

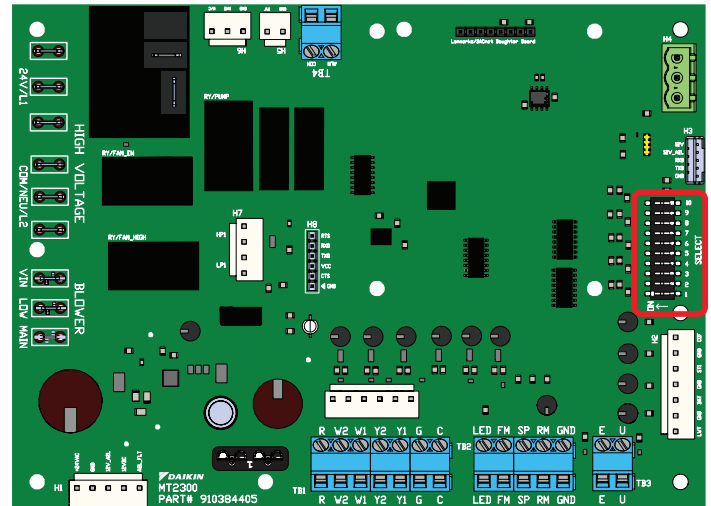

CAUTION

The MT2300 unit controller incorporates static sensitive devices. A static charge from touching the device can damage the electronic components. To help prevent damage during service, use static discharge wrist straps. Static discharge wrist straps are grounded to the heat pump chassis through a 1M ohm resistor.

Table 3: MT2300 Main board DIP switch settings

Switch	Description	Position	Model/Options
SW1	Normal/Test Mode	SW1 = OFF (0)	Normal Operation
		SW1 = ON (1)	Service/Test Mode
SW2	Fan Operation	SW2 = OFF (0)	Continuous Fan Operation (On)
		SW2 = ON (1)	Cycling Fan Operation (Auto)
SW3	Loop Fluid	SW3 = OFF (0)	Water Loop Fluid
		SW3 = ON (1)	Glycol Loop Fluid
SW4	Freeze Fault Detect (FFD)	SW4 = OFF (0)	Disabled FFD
		SW4 = ON (1)	Enabled FFD with LWT sensor installed
SW5	Room Sensor Setpoint Adjust Range	SW5 = OFF (0)	Short Range -5 to +5 F (-2.78 to +2.78 C)
		SW5 = ON (1)	Long Range 55 to 95 F (12.78 to 35 C)
SW6	Thermostat/Room Sensor Control	SW6 = OFF (0)	Thermostat Control
		SW6 = ON (1)	Room Sensor Control
SW7/ SW8	Single Compressor Heating Source	SW7 = OFF (0)	Allow Compressor in Heating Mode
		SW7 = ON (1)	Disable Compressor in Heating Mode
	Single Compressor IO Expansion Module	SW8 = OFF (0)	IO Expansion Module Not Required
		SW8 = ON (1)	IO Expansion Module is Required
	Two Compressor Availability	SW7 = OFF (0) SW8 = OFF (0)	Both Compressors Available (Automatic Compressor Fail Replace)
		SW7 = ON (1) SW8 = OFF (0)	Lead Compressor Available (Lag Compressor is Off-Line)
	SW7 = OFF (0) SW8 = ON (1)	No Compressors Available	
SW9	WSHP Base Board Application Select	SW9 = OFF (0)	Single Compressor WSHP Application
		SW9 = ON (1)	Two Compressor Application
SW10	Discrete/Variable Speed Fan Select	SW10 = OFF (0)	Fan Single (Fan Main Output) or Variable (PWM) Speed
		SW10 = ON (1)	Dual Speed Fan (Low & High Discrete Outputs)

NOTE: The functionality of SW7 and SW8 depends on the setting of SW9. If SW9 is OFF, SW7 and SW8 will be for Heating Source and I/O Expansion Module functionality. If SW9 is ON, SW7 and SW8 will be for Compressor Availability functionality.

⚠ WARNING

Proper antifreeze/water solution is required to minimize the potential of fluid freeze-up. DIP switch 3 (SW3) is factory set for water freeze protection with the switch in the OFF position. Operation at fluid temperatures below 32°F with anti-freeze protection requires SW3 to be field configured for the switch on. If unit is employing a fresh water system (no anti-freeze protection), it is extremely important that SW3 setting remains in the OFF position (factory default setting) in order to shut down the unit at the appropriate water temperature to protect your heat pump from freezing. Failure to do so can result in unit damage, property damage and will void unit warranty.

Table 4: MT2310 I/O expansion module DIP switch settings

Switch	Description	Position	Model/Options
SW1-4	Variable Fan Speed Row Selection	0000 to 1111 Binary	Variable Speed Fan Row Selection (1 to 16), used when "nciVsNetCnfgEn" is set to "Disable" the network override.
SW5/ SW6	Secondary Heating Options	SW5 = OFF (0) SW6 = OFF (0)	None
		SW5 = ON (1) SW6 = OFF (0)	Supplemental Electric Heat
		SW5 = OFF (0) SW6 = ON (1)	Boilerless Electric Heat
		SW5 = ON (1) SW6 = ON (1)	Hydronic Heating
SW7	Hot Gas Reheat (HGR)	SW7 = OFF (0)	HGR Disabled
		SW7 = ON (1)	HGR Enabled
SW8	Waterside Economizer (WSE)	SW8 = OFF (0)	Waterside Economizer Disabled
		SW8 = ON (1)	Waterside Economizer Enabled
SW9	WSHP IO Expansion Application Select	SW9 = OFF (0)	Single Compressor Application
		SW9 = ON (1)	Two Compressor Application
SW10	Single Compressor: Speed	SW10 = OFF (0)	Single Speed Compressor
		SW10 = ON (1)	Dual Speed Compressor
	Two Compressor: Lead Compressor Select	SW10 = OFF (0)	Compressor #1 is Lead
		SW10 = ON (1)	Compressor #2 is Lead

NOTE: The functionality of SW10 depends on the setting of SW9. If SW9 is OFF, SW10 will be for Single Compressor Speed. If SW9 is ON, SW10 will be for Lead Compressor Select.

Figure 3: MT2310 I/O Expansion DIP Switches

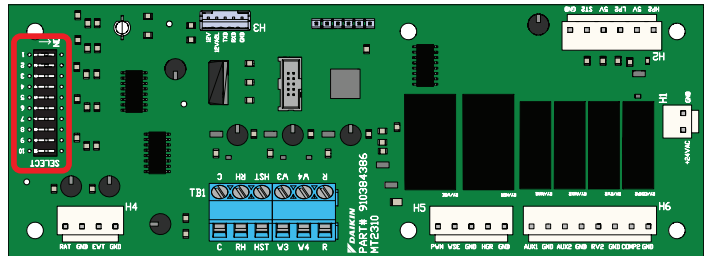

Functionality

The MT2300 is the base unit controller for the Daikin Applied water source heat pump control platform. The MT2300 controls the heat pump in all modes of operation, including:

- Single State Compressor
- Single/Two-speed Fan (Induction or ECM)
- Loop Pump On/Off
- Reversing Valve On/Off
- Alarm (Dry Contacts)
- Network Integration (with a BACnet Communications Module)

The controller can be used with thermostat or sensor control.

All MT2300 unit controller inputs must be activated by dry contacts powered by the control board's power terminals or approved Daikin Applied sensors. No solid state devices (Triacs) may be used to operate MT2300/MT2310 unit controller inputs. No external power sources may be used to operate MT2300. All units must be properly grounded per local code requirements. See the Installation and Maintenance bulletin specific to your Water Source Heat Pump.

Connecting a MT2310 expansion board to the main controller allows:

- Compressor High Capacity On/Off Control
- Variable Speed Fan Control
- Water Side Economizer Control
- Active Hot Gas/Reheat (HGR), or Low Capacity Dehumidification Options
- Boilerless & Supplemental Auxiliary Heating Options
- The Third and Fourth Thermostat Heating Stage (W3 and W4) Input
- Hydronic Heating Control

The I/O of the MT2300 unit controller can be extended to support additional functions with the MT2310 expansion board.

Your Daikin water source heat pump will be delivered with the correct unit controls installed to support the specific unit configuration.

Operating Modes

- **Occupied Mode** – When in the occupied mode, the unit will be controlled to its occupied setpoint conditions. The occupancy mode can be established by a BACnet communication signal, from a room sensor equipped with “Occupied/Unoccupied” mode functions, or a thermostat equipped with an “Occupied/Unoccupied” mode switch. The occupancy state will be displayed on sensors equipped with a status indicator.
- **Unoccupied Mode** – When in the unoccupied mode, the unit will be controlled to its unoccupied setpoints. The occupancy state will be displayed on sensors equipped with a status indicator.
A contact closure between terminals U and C on the MT2300 unit controller will place the unit into the

unoccupied mode for night setback/setup operation.

Thermostat equipped units will be controlled from Y2, W2, W3, W4 and DH inputs. The fan will cycle according to a call for cooling, heating, or dehumidification.

- **Override Mode** – A momentary (4 to 10 seconds) press of the “Override” button on the thermostat or room sensor during the unoccupied mode will cause the unit to operate in the occupied mode for up to two hours, for after-hours heating, cooling or dehumidification. “OVERRIDE” will be displayed on sensors equipped with override button and status indicator.
- **“Energy Save” Standby** – BACnet units configured for Room Sensor Control can receive a signal from the Building Automation System (BAS) to initiate the energy savings mode. This mode is typically initiated by the BAS with smart grid technologies to save energy. The savings are driven by reducing peak electrical demand for the building. Once initiated, the MT2300 SmartSource® unit controller will reset its effective setpoint to minimize compressor operation. “E-SAVE” will be displayed on sensors equipped with bypass mode annunciation capabilities.
- **Remote Shutdown** – When the unit is in the remote shutdown mode, unit operation is suspended. A contact closure between terminals E and C on the MT2300 unit controller will place the unit into remote shutdown mode.

Safety Inputs (HPS, LPS, SLTS, COS)

The control inputs are High Pressure Switch (HPS), Low Pressure Switch (LPS), Suction Line Temperature Sensor (SLTS), Condensate Overflow Sensor (COS). These inputs are active while the unit is in any occupancy mode. Protect unit components by disrupting normal operation as follows:

- **High Pressure Switch (HPS)** – Normally closed switch that opens on a high refrigerant pressure condition. Control generates a high pressure fault and disables the compressor output when the switch is open. High pressure inputs are only valid when the compressor output relay is energized.
- **Low Pressure Switch (LPS)** – Normally closed switch that opens on a low refrigerant pressure condition. Control generates a low pressure fault and disables the compressor output when the switch is open.
- **Suction Line Temperature Sensor (SLTS)** – Monitors refrigerant suction line temperature. When the suction temperature drops below the cutout setpoint, the control generates a low temperature fault and disables the compressor output.
- **Condensate Overflow Sensor (COS)** – Senses condensate level in condensate pan. When the sensor indicates a potential overflow condition, the control generates a condensate overflow fault and disables the compressor output. Condensate overflow alarm is disabled in the heating mode.

Control Outputs

- **The thermostat alarm output:** Will be energized when there are fault conditions presently active. Without any fault conditions active, the alarm output shall be de-energized. When energized the onboard relay closes the connection between TB4 ALM and COM. For a 24VAC output from ALM, connect a 24VAC source to COM.
- **Isolation Valve / Pump Request [IV/PR (H6)]:** is selectable to be energized when the compressor is off (normally closed), or when the compressor is on (normally open), by moving the wire lead to the appropriate terminal.
- **Reversing Valve:** 24V signal that is energized upon a call for heat mode.

Figure 4: TB4, H5, and H6 Terminals on MT2300 Board

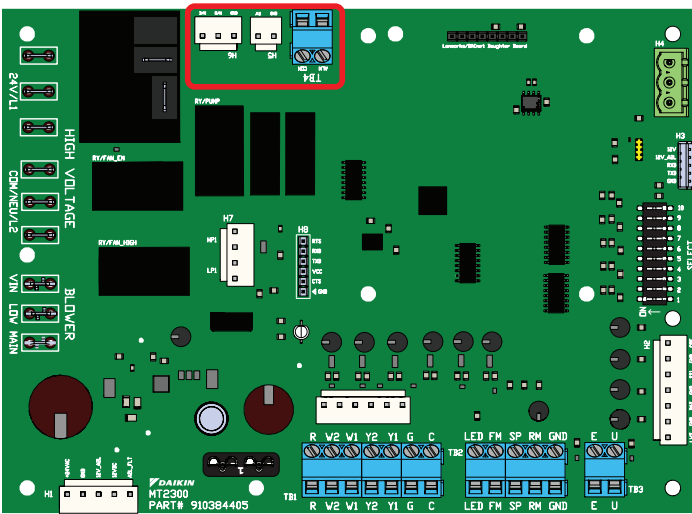
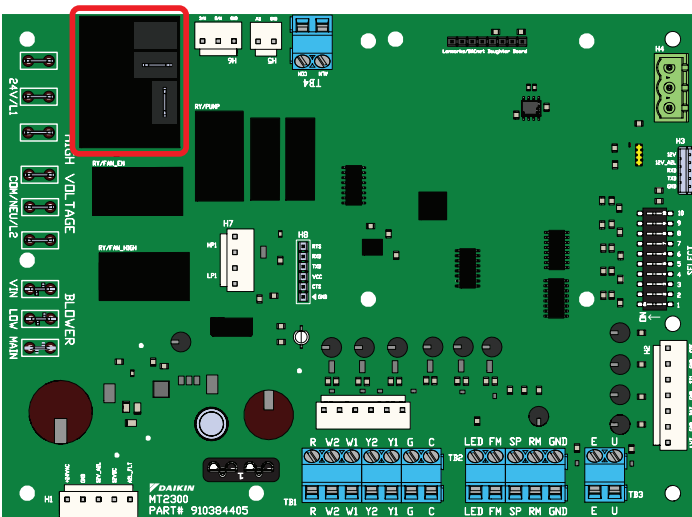

Figure 5: Compressor Relay Terminals on MT2300 Board



- **Compressor Relay:** Line or low voltage output used to control compressor. (On/Off)

LED Indicators

When the unit controller or I/O boards are communicating a certain fault or mode, the LED indicator will flash a designated pattern or sequence. See below for the location of the LED indicator on each board.

Figure 6: LED Indicator on MT2300 Board

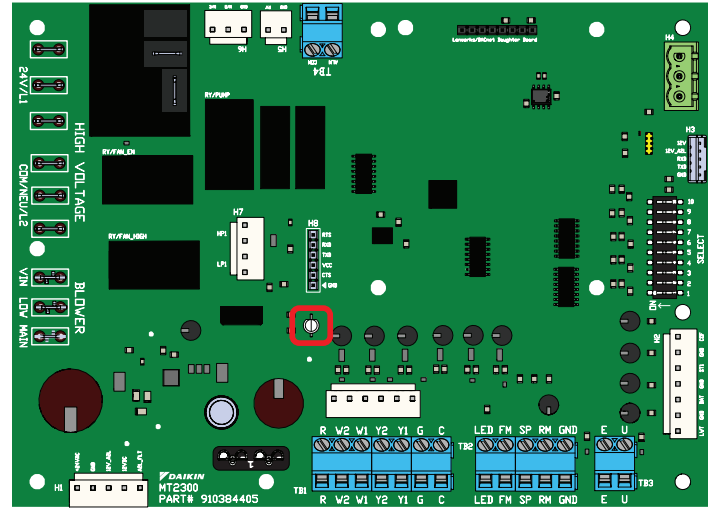
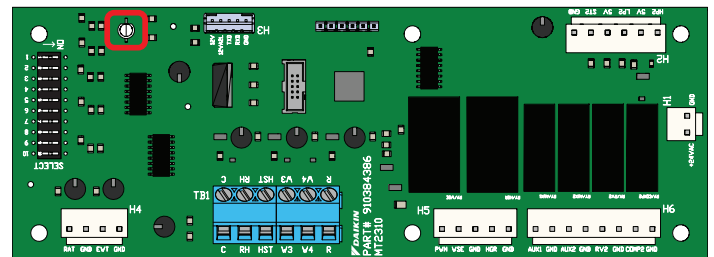

Figure 7: LED Indicator on MT2310 I/O expansion board



Sequence Of Operation

Fan Only

On a call for fan the fan starts immediately through the activation of the Thermostat G terminal or Room Sensor Fan Switch.

LED Activity	Type	Color	Description
1 Flash	Mode	Green	No Call for Heating/Cooling/Dehumidification
4 Flash	Mode	Green	Call for Fan Only

NOTE: If configuration switch SW2 on the main control board is OFF the fan will run continuous whenever there is a power supply to the unit. For cycling fan operation configuration switch SW2 needs to be on.

Cooling

LED Activity	Type	Color	Description
1 Flash	Mode	Green	No Call for Heating/Cooling/Dehumidification
2 Flash	Mode	Green	Call for Cooling

On a call for 1st stage cooling from a thermostat or network setpoint, the H6 output on the MT2300 board is activated to open the motorized valve to allow water flow through the heat exchanger. The fan starts immediately (unless it is already on through activation of the G terminal by the thermostat fan switch "ON" or a wall sensor command) at "FAN ONLY" setting. The compressor starts after 60 seconds to make sure the motorized valve has fully open for proof of water flow and the fan CFM output increases. The compressor minimum on timer of 180 seconds starts. The reversing valve will de-energize 5 seconds after the compressor starts. The fan CFM output is now determined by the MT2310 I/O board configuration switches SW1-SW4 and the corresponding stage 1 CFM. If a two stage thermostat is used, a further demand for cooling will change (increase) the CFM output of the EC fan motor.

When the room setpoint conditions are satisfied, the compressor will shut off and the fan will either shut off (fan switch "AUTO") or continue to run (fan switch "ON" or configuration switch SW2 is OFF). The compressor minimum off timer of 360 seconds will start.

Heating

LED Activity	Type	Color	Description
1 Flash	Mode	Green	No Call for Heating/Cooling/Dehumidification
3 Flash	Mode	Green	Call for Heating

On a call for 1st stage heating, from a thermostat or network setpoint, the H6 output on the MT2300 board is activated to open the motorized valve to allow water flow through the heat exchanger. The fan starts immediately (unless it is already on through activation of the G terminal by the thermostat fan switch "ON" or a wall sensor command) at low CFM. The compressor starts after 60 seconds to make sure the motorized valve has fully open for proof of water flow and the fan CFM output increases. The compressor minimum on timer of 180 seconds starts. The reversing valve will energize 5 seconds after the compressor starts. The fan output is now determined by the MT2310 I/O board configuration switches SW1-SW4 and the

corresponding stage 1 CFM. If a two stage thermostat is used, a further demand for heating will change (increase) the CFM output of the EC fan motor. When the room setpoint conditions are satisfied, the compressor will shut off and the fan will either shut off (fan switch "AUTO") or continue to run (fan switch "ON" or configuration switch SW2 is OFF). The compressor minimum off timer of 360 seconds starts.

Boilerless Electric Heat Mode

Units equipped with the boilerless electric heat option include an entering water temperature sensor. On a call for heating the fan starts immediately (unless it is already enabled through activation of the G terminal from the thermostat fan switch "ON" or a wall sensor command.) at "FAN ONLY" setting. The H6 output on the MT2300 board is activated to open the motorized valve allowing water flow thru the heat exchanger. If the entering water temperature is below set point, (55°F standard units or 28°F for geothermal units), the MT2300 controller will disable the compressor, increase the fan speed to electric heat CFM and energize a 24VAC output to the electric heat control circuit. When the room setpoint conditions are satisfied, the electric heater will turn off and the fan will either cycle off (fan switch "AUTO") or continue to operate (fan switch "ON" or configuration switch SW2 is OFF). If the entering water temperature is above setpoint, the unit will operate in compressor heating mode. The setpoints are adjustable by the BAS.

Supplemental Electric Heat Mode

On a call for supplemental electric heat (W3) or BMS setpoint, the compressor will continue to operate, the fan speed will increase to the electric heat setting and electric heating will energize. For units equipped with two stages of electric heat, W4 or BMS setpoint will turn on second stage of electric heat.

Emergency Electric Heat Mode

On a call for emergency heat, the fan will energize at its "electric heat" setting. When the room setpoint conditions are satisfied, electric heat will be de-energized. The fan will operate according to its "FAN ONLY" setting when enabled, for continuous fan operation. If fan cycling is enabled, the fan will turn off once room setpoint conditions are satisfied. A 24V control signal to TB1-W4 from the thermostat or BMS will initiate a call for stage 2 electric heat.

Hydronic Heat Mode

This mode requires optional hydronic heat factory installed on vertical units. A hydronic coil, 3-way valve and entering water temperature sensor are included with this option. The purpose of this mode is to satisfy the heating demand by using the elevated loop water temperature between 90°F and 120°F.

On a call for 1st stage heating with entering loop water above 90°F the H6 output on the MT2310 I/O expansion module is activated to open the motorized valve diverting water flow to the hydronic coil. The fan starts after 30 seconds (unless it is already activated by the thermostat or room sensor). The fan output is determined by the MT2310 I/O expansion module configuration switch. When the room setpoint conditions are satisfied, the

3-way valve will close and the fan will either shut off (fan switch "AUTO") or continue to run (fan switch "ON" or configuration switch SW2 is OFF). When entering loop water temperature is below 90°F, standard heating operation resumes.

Smart Dehumidification (Hot Gas Reheat)

LED Activity	Type	Color	Description
1 Flash	Mode	Green	No Call for Heating/Cooling/Dehumidification
6 Flash	Mode	Green	Call for Dehumidification

This mode requires optional hot gas reheat and a humidistat input to the MT2310 I/O expansion module. This option also utilizes airflow management. If the space cooling temperature setpoint is satisfied, but the humidity is above the space humidity setpoint, the dehumidification mode is activated. The return air temperature must be 68°F or greater.

On a call for smart dehumidification, the fan will energize at its fan only setting, the pump will energize. After the 60 second flow timer and the compressor minimum off timer expire (360 seconds), the fan will operate at the dehumidification setting, the compressor will energize at full load operation and the hot gas reheat valve will open, sending hot gas to the reheat coil. The return air is cooled and reheated to near space temperature. When the space humidity setpoint is satisfied the compressor will turn off and the fan will operate according to its fan setting.

During smart dehumidification operation, a call for cooling will close the hot gas reheat valve and the unit will resume normal cooling operation until the space temperature is satisfied.

Simplified Dehumidification (Thermostat control only)

This mode helps control space humidity by reducing the CFM as the space temperature approaches the thermostat cooling setpoint without hot gas reheat. The return air temperature must be 68°F or greater for 1st stage operation. A multi-stage thermostat is used to provide compressor cooling with multiple airflows. Using a 3 cooling stage thermostat the following occurs: On a call for 1st stage cooling (Terminal TB1-3, HST on the MT2310 I/O expansion module), the H6 output on the MT2300 board enables the pump or motorized valve to direct water flow through the coaxial heat exchanger. The fan starts immediately (unless it is already on) at the dehumidification CFM. If the return air temperature is 68°F or greater, the compressor starts after the 60 second flow timer and the 360 second compressor minimum off timer has expired. The compressor minimum on timer of 180 seconds starts. On a call for cooling, stage 2 (Terminal Y1), the fan output will increase to the cooling stage 1 CFM. On a call for cooling, stage 3 (Terminal Y2), the fan output will increase to the cooling stage 2 CFM. The unit attempts to satisfy cooling at the lowest possible CFM for maximum dehumidification. When the room setpoint conditions are satisfied, the compressor will shut off and the fan will either shut off (fan switch "AUTO") or continue to run (fan switch "ON" or configuration switch SW2 is OFF).

Humidistat Controlled Dehumidification

This mode helps control space humidity by using space humidity

sensing and by reducing the CFM by use of a humidistat in lieu of a thermostat. The humidistat control replaces stage 1 thermostat control as described above in simplified dehumidification operation. The TB1-3, HST terminal is controlled by the humidistat enabling dehumidification fan speed with compressor operation. The return air temperature must be 68°F or greater.

Waterside Economizer

This mode requires the optional factory-installed waterside economizer. A hydronic economizer coil, 3-way motorized valve and an entering water temperature (EWT) sensor are added to the unit.

For single stage SmartSource units with WSE option

Hydronic cooling operation is adjustable between 50°F and 70°F via BACnet or LON communication (factory default of 65°F).

- On a call from Y1 or cooling stage 1 setpoint, and the EWT is below the hydronic cooling setpoint, but above 45°F, the unit will operate in hydronic cooling mode. (The 3-way valve is energized and the fan operates at the hydronic cooling CFM setting).
- On a call from Y2 of the thermostat or second stage cooling setpoint, and the EWT is below the hydronic cooling setpoint, but above 45°F, the unit will operate in hydronic cooling mode and full load mechanical cooling. (The fan will operate at the full load cooling CFM).

If at any time the EWT rises above the entering water temperature setpoint plus 5°F (while operating) or below 45°F, the 3-way valve will de-energize, disabling WSE operation.

If WSE is not available due to entering water temperatures out of range, the sequence becomes:

- On a call from Y1 or cooling stage 1 setpoint, the unit operates at full load mechanical cooling. (The fan will operate at the full load cooling CFM).

On a call from Y2 or cooling stage 2 setpoint, status the same as above.

For 2-stage SmartSource units with WSE option

Hydronic cooling operation is adjustable between 50°F and 70°F (factory default of 65°F).

- On a call from Y1 or cooling stage 2 setpoint, and the EWT is below the hydronic cooling setpoint, but above 45°F, the unit will operate in hydronic cooling mode. (The 3-way valve is energized and the fan operates at the hydronic cooling CFM setting).
- On a call from Y2 of the thermostat or BMS cooling stage 2 setpoint, and the EWT is below the hydronic cooling setpoint, but above 45°F, the unit will operate in hydronic cooling mode and part load mechanical cooling. (The fan will operate at the part load cooling CFM).
- On a call from Y3 of the thermostat or cooling stage 3 setpoint, and the EWT is below the hydronic cooling setpoint, but above 45°F, the unit will operate in hydronic cooling mode and full load mechanical cooling. (The fan will

operate at the full load cooling CFM).

If at any time the EWT rises above the entering water temperature setpoint plus 5°F (while operating) or below 45°F, the 3-way valve will de-energize, disabling WSE operation.

If WSE is not available due to entering water temperatures out of range, the sequence becomes:

- On a call from Y1 or cooling stage 1 setpoint, the unit operates at part load mechanical cooling. (The fan will operate at the part load cooling CFM).
- On a call from Y2 or cooling stage 2 setpoint, status the same as above
- On a call from Y3 or cooling stage 3 setpoint, the unit goes to full load mechanical cooling. (The fan will operate at the full load cooling CFM).

The minimum off timer of 360 seconds starts. If the loop temperature increases above the changeover temperature, waterside economizer mode will be suspended and the unit will resume normal mechanical cooling mode with stage 1 of the thermostat or network setpoint now starting the compressor.

NOTICE
To prevent compressor cycling and all compressors from starting up together after loss of power, the required minimum on/off time default is 300 seconds plus the random restart of 0 to 60 seconds. This may cause the compressor time delay to be longer than indicated above.

NOTICE
For a unit with both water side economizer and hot gas reheat, Y3 from the thermostat will be wired to W4 on the MT2310 I/O expansion module.

Unit Status

Unoccupied Operation – Stand Alone Thermostat Control

The board will be in unoccupied mode if the unoccupied terminal (U) is grounded.

LED Activity	Type	Color	Description
5 Flash	Mode	Green	Unoccupied Mode Active

Figure 8: Terminal “U” - Grounded for Unoccupied

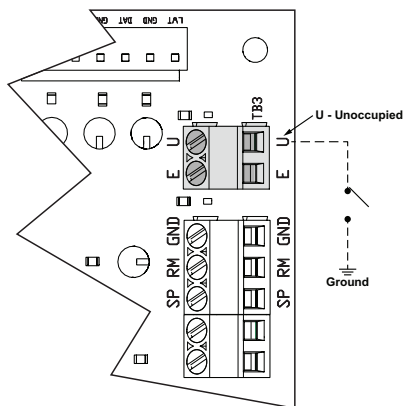

Remote Shutdown

LED Activity	Type	Color	Description
Rapid Flash	Mode	Green	Emergency Shutdown

When the TB3-E terminal is grounded, the MT2300 unit controller enters remote shutdown mode. Remote shutdown is provided so that when properly connected to a building automation system, remote switch, etc., the E terminal can be used to shut down the water source heat pump.

Figure 9: Terminal “E” - grounded for remote shutdown

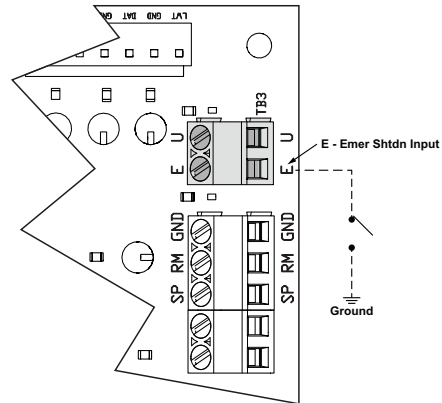

When in remote shutdown (E terminal grounded), control inputs have no affect upon unit operation. No faults or modes have higher priority than remote shutdown. Remote shutdown and brownout condition have the same level of priority. See Table 6 on page 16.

When the unit is in remote shutdown mode, the following occurs:

1. The compressor de-energizes (if enabled).
2. The fan de-energizes (if enabled).
3. Fault terminal (ALM) will remain de-energizes because emergency shutdown is a “mode.”

When the E terminal is no longer grounded the unit will automatically return to normal operation.

NOTICE
The remote shutdown input (E) will suspend unit operation. Disconnect power when servicing the unit/controller.

Thermostat Inputs (G, Y1, Y2, W1, W2, W3, and W4)

For units with both waterside economizer and hot gas reheat, the only thermostat inputs used during unoccupied operation are Y3, and W2/W3, which when energized will activate Cooling Mode or Heating Mode respectively. Inputs G, Y1 and W1 have no effect during unoccupied mode.

For all other units, the only thermostat inputs used during unoccupied operation are Y3, and W2/W3/W4, which when energized will activate Cooling Mode or Heating Mode respectively. Inputs G, Y1 and W1 have no effect during unoccupied mode.

Fault Modes

Brownout

LED Activity	Type	Color	Description
1 Flash	Fault	Yellow	Compressor Low Voltage Brownout

Brownout condition is provided to protect the water source heat pump's motor electrical damage due to low voltage conditions.

The MT2300 unit controller is designed to monitor the 24VAC power supply to the board. If the line voltage supplied to the water source heat pump drops, the 24VAC supply to the control board will also drop. When the line voltage supplied to the unit drops below approximately 80% of the unit nameplate rated value, the controller goes into brownout condition. The controller remains in brownout condition until line voltage returns to approximately 90% of the unit nameplate value.

When in brownout condition, thermostat and control inputs have no affect upon unit operation. Remote shutdown and brownout conditions have the same level of priority. See [Table 6 on page 16](#).

When the unit is in brownout condition the following occurs:

1. The compressor de-energizes.
2. The IV/PR (H6) output will change state. (On to Off / Off to On).
3. The fan de-energizes.
4. Alarm terminal (TB4-ALM) energizes (fault). TB4-ALM will close to AB4-COM to indicate an alarm signal. When the line voltage supplied to the unit returns to acceptable levels (90% of nameplate) the controller returns to the current mode.

High / Low Pressure Faults (HP/LP)

Normally closed high and low refrigerant pressure switches help protect the water source heat pump from excessively high or low refrigerant pressures. The MT2300 unit controller monitors these switches individually. If the compressor is running and the HP circuit is open, the controller enters a pressure fault mode. If the LP circuit is open after a time delay (default of 30 seconds, adjustable if a communication module is present) the controller enters a low pressure fault mode.

LED Activity	Type	Color	Description
1 Flash	Fault	Red	Compressor #1 High Pressure
2 Flash	Fault	Red	Compressor #1 Low Pressure

See [Table 6 on page 16](#).

When the unit is in high or low pressure fault modes the following occurs:

1. The compressor de-energizes.
2. The IV/PR (H6) output will change state. (On to Off / Off to On).
3. The fan de-energizes.
4. The alarm terminal (TB4-ALM) energizes (fault). TB4-ALM will close to TB4-COM to indicate an alarm signal.

High Pressure/Low Pressure Reset

After the HP circuit is closed, the unit does not return to normal operation until the alarm is manually reset. The unit is locked out in this manner until the unit can be serviced.

The alarm is reset by a short interruption of unit power, by holding down the tenant override button for more than 10 seconds, or via the Building Automation System (BAS).

Low Suction Temperature Fault Heating

1. When the suction line temperature falls below 28°F (standard range) or 6.5°F (Geothermal) the compressor output is disabled.
2. The control will attempt to recover from a low suction temperature condition by defrosting the water heat exchanger (coaxial coil). See [“Defrost Sequence of Operation \(Heating\)”](#)
3. When the suction line temperature increases by the Low Temp Protect Diff (the default is 8°F) degrees.
4. The compressor is available for heating when the compressor minimum off timer has expired.

Defrost Sequence of Operation (Heating)

1. Immediately turn off the compressor if operating in the cooling or dehumidification modes.
2. The reversing valve output is de-activated, placing the reversing valve in the cooling mode and moving warm refrigerant to the coax coil.
3. Fan speed is not changed, however “Heat Stage #1” speed is used if the fan is presently off.
4. If the compressor was on at the beginning of the defrost process, then start the 60 second fixed defrost timer.
5. Wait for the defrost timer to expire.
6. If the alarm condition has cleared:
 - Return to normal operation.
7. If the alarm condition remains active:
 - Compressor High Capacity is turned off
 - Compressor is immediately turned off, ignoring the Compressor Minimum ON timer
 - Compressor is disabled for heating, cooling, and

dehumidification

- Electric heating can be used if it is available
- Fan and pump remain available for operation
- Alarm output energizes.
- When the suction line temperature recovers to 36°F standard equipment (14.5°F on geothermal) the low temperature fault continues and the compressor will be locked out.

Low Suction Temperature Fault Cooling / Dehumidification

When the suction line temperature falls below 28°F, the compressor output is disabled. The fan will continue to run allowing the air coil to defrost. Once the suction line temperatures increases 8°F (default) the compressor will be enabled once the compressor minimum off time has expired.

LED Activity	Type	Color	Description
4 Flash	Fault	Red	Compressor #1 Low Suction Temp

Condensate Overflow

LED Activity	Type	Color	Description
7 Flash	Fault	Yellow	Condensate Overflow

The MT2300 unit controller's condensate sensor is designed to detect excessively high condensate water levels in the drain pan. When high condensate water levels are detected during cooling or dehumidification modes, the controller enters into condensate fault mode. The fan operates at fan only speed during the condensate overflow fault mode. The controller will continue to operate in heat mode.

Some faults and modes have higher priority than condensate overflow mode. See [Table 6 on page 16](#).

When the unit senses a condensate overflow fault while in cooling mode the following occurs:

1. The compressor de-energizes.
2. The alarm terminal (TB4-ALM) energizes (fault). TB4-ALM will close to TB4-COM to indicate an alarm signal.

When condensate levels return to normal, the controller will automatically return to normal operation.

Remote Reset of Automatic Lockouts

The Remote Reset feature provides the means to remotely reset automatic lockouts. There are (3) ways to accomplish a unit reset once the fault condition has been remedied:

- Using the thermostat cycle from cool or heat to off and back to heat or cool two times within 30 seconds
- Press the Room Sensor or Thermostat Timed Override/Reset Button for more than 10 seconds
- Turn the unit power off and wait 10 seconds to turn back on.

When the cause of the fault condition has been remedied, and the unit is cycled from not requiring heating or cooling to needing

heating or cooling twice within 30 seconds (accomplished by user manipulation of the Heat/Cool/ Auto/Off switch on the thermostat), an alarm reset equivalent to a tenant override button reset is generated. The intelligent reset counter and the 24 hour timer are cleared when this type of alarm reset is generated.

NOTICE

This feature only applies to thermostat controlled systems.

For room sensor controlled units, pressing the "Override" or "Reset" button for more than 10 seconds will apply a ground signal to the Room Temperature Sensor connection at TB2 pin 4, RS clearing the lockout alarm once the cause of the fault condition has been remedied.

A unit power cycle can also be used to clear an automatic lockout if the conditions causing the fault have been remedied.

Fan Operation During Most Modes, Faults and Shutdowns

The MT2300 unit controller allows fan operation during most modes, faults and shutdowns to facilitate maximum space comfort and control. However, the fan does not operate during brownout or emergency shutdown condition. During most modes, faults, or shutdowns the fan will operate normally.

Operation with the High Speed Configuration Switch

The MT2300 unit controller includes a high-speed configuration switch to speed system check out and trouble-shooting. See [Figure 2 on page 6](#) for SW1 location.

NOTICE

This switch is intended for factory unit testing and should only be used by trained service technicians as several timing functions are reduced to speed system check out.

- Disconnect power to the unit when changing the position of the SW1 configuration switch.
- The high speed switch should only be used for a short period of time for testing of the unit's operation by a trained service technician. The switch must be set to off for normal unit operation.
- If the switch is left on after system check out, the unit may be damaged.

Status LED Indication

The MT2300 and the MT2310 boards each have a three-color status LED that provide operational mode and alarm notification. Mode LED flashes have an ON/OFF interval of 250ms ON and 750ms OFF between cycles. Fault LED flashes have an ON/OFF interval of 250ms ON and 1.5 second OFF between cycles. Rapid LED flashes are ON/OFF at 150ms intervals with no interval cycle.

Table 5: Room sensor status LED

LED On Time (Sec)	LED Off Time (Sec)	Operating Mode
0.5	0.5	Alarm Condition or Network "Wink" Operation Active
0.0	Continually	Bypass Mode is Active
0.5	5.5	Unoccupied Mode
5.5	0.5	Standby Mode
Continually	0.0	Occupied Mode

Faults and Modes

Table 6: Priority level of faults and modes, and resets

Alarm Enumeration (BACnet)	Fault	Indication	Reset ¹
1	No Alarm	Normal operation	NA
2	MT2310 Communication Failure	Single compressor unit with SW #8 set to ON position	A
3	Incompatible Software	Incorrect Software Part or Version Numbers	P
4	Invalid Configuration	Base & IO Exp Application Mismatch or MT2310 detected but not required (SW #8)	P
5	A2L Alarm	A2L refrigerant leak detected	A
6	A2L Error - Power	A2L mitigation control is not powered	A
7	Compressor Low Voltage	"Brownout" condition exists	A
8	Comp #1 High Pressure	Compressor #1 high pressure switch opened	T,N
9	Comp #2 High Pressure	Compressor #2 high pressure switch opened	T,N
10	Comp #1 Low Pressure	Compressor #1 low pressure switch opened	T,N
11	Comp #2 Low Pressure	Compressor #2 low pressure switch opened	T,N
12	Comp #1 Suction Temp Sensor	Compressor #1 suction temp sensor failure	N
13	Comp #2 Suction Temp Sensor	Compressor #2 suction temp sensor failure	N
14	Leaving Water Temp (LWT) Sensor	LWT sensor not present (SW #4 = ON)	N
15	Freeze Fault Detect (FFD)	LWT sensor temp below freeze setpoint (SW #4 = ON)	T,N
16	Comp #1 Low Suction Temp (ST1)	ST1 sensor temp below minimum setpoint	A,T,N ²
17	Comp #2 Low Suction Temp (ST2)	ST2 sensor temp below minimum setpoint	A,T,N ²
18	A2L Error - Sensor	A2L sensor lost communication or reported failure	A
19	Control Temp Sensor Failure	Room Temp and Return Air Temp sensor failures	N
20	Entering Water Temp (EWT) Sensor Failure	EWT sensor reading "out of range"	N
21	Room Temp Sensor Failure	Room temp sensor reading "out of range"	N

Alarm Enumeration (BACnet)	Fault	Indication	Reset ¹
22	Return Air Temp Sensor Failure	RAT sensor reading "out of range"	N
23	Space RH Sensor Failure	Space RH sensor reading "out of range"	N
24	Low Entering Water Temp (EWT)	EWT sensor reading below minimum setpoint	A
25	Condensate Overflow	Condensate overflow sensor indicates water present	A,N
26	Waterside Economizer (WSE) Low Temp	WSE temp sensor reading below minimum setpoint	A

NOTE 1: "A" = Auto Reset, "T" = Tenant Override Button Reset, "N" = Network Reset, "P" = power cycle only

NOTE 2: Low suction temperature faults have "Intelligent Reset" logic - 3 faults in a 24 hour period disables the auto reset function.

Table 7: MT2300 Unit Controller Status LEDs

LED Activity	Type	Color	Description
Steady ON	Fault	Yellow	MCU Not Programmed
Steady ON	Fault	Red	MCU Hardware Failure
1 Flash	Fault	R-Y-G	Invalid Configuration
2 Flash	Fault	R-Y-G	Incompatible Software
1 Flash	Fault	R-Y	I/O Exp Board Communications Fail
1 Flash	Mode	G-Y	Service / Test Mode Active
Rapid Flash	Fault	Red	A2L Mitigation – Refrigerant Leak
1 Flash	Fault	Red	Compressor #1 High Pressure
2 Flash	Fault	Red	Compressor #1 Low Pressure
3 Flash	Fault	Red	Compressor #1 Suction Temp Sensor Fail
4 Flash	Fault	Red	Compressor #1 Low Suction Temp
5 Flash	Fault	Red	Compressor #2 High Pressure
6 Flash	Fault	Red	Compressor #2 Low Pressure
7 Flash	Fault	Red	Compressor #2 Suction Temp Sensor Fail
8 Flash	Fault	Red	Compressor #2 Low Suction Temp
9 Flash	Fault	Red	A2L Mitigation – Control Board Without Power
10 Flash	Fault	Red	Compressor #1 High Discharge Temp
11 Flash	Fault	Red	Compressor #2 High Discharge Temp
Rapid Flash	Mode	Yellow	A2L Mitigation – Refrigerant Sensor Fail
1 Flash	Fault	Yellow	Compressor Low Voltage Brownout
2 Flash	Fault	Yellow	Freeze Fault Detect (FFD)
3 Flash	Fault	Yellow	Control Temp Sensor Fail
4 Flash	Fault	Yellow	Entering Water Temp Sensor Fail
5 Flash	Fault	Yellow	Leaving Water Temp Sensor Fail
6 Flash	Fault	Yellow	Relative Humidity Sensor Fail
7 Flash	Fault	Yellow	Condensate Overflow
8 Flash	Fault	Yellow	Space Temp Sensor Fail
9 Flash	Fault	Yellow	Return Air Temp Sensor Fail

LED Activity	Type	Color	Description
Rapid Flash	Mode	Green	Emergency Shutdown
1 Flash	Mode	Green	No Call for Heating / Cooling / Dehumidification
2 Flash	Mode	Green	Call for Cooling
3 Flash	Mode	Green	Call for Heating
4 Flash	Mode	Green	Call for Fan Only
5 Flash	Mode	Green	Unoccupied Mode Active
6 Flash	Mode	Green	Call for Dehumidification
7 Flash	Mode	Green	Low Entering Water Temp
8 Flash	Mode	Green	HGR Low Return Air Temp Cutout
9 Flash	Mode	Green	WSE Low Temp Cutout

Table 8: MT2310 I/O Expansion Board Status LEDs

LED Activity	Type	Color	Description
1 Flash	Mode ¹	Green	Variable Speed Fan OFF
2 Flash	Mode ¹	Green	Variable Speed Fan ON: 0 to 20%
3 Flash	Mode ¹	Green	Variable Speed Fan ON: 21 to 30%
4 Flash	Mode ¹	Green	Variable Speed Fan ON: 31 to 40%
5 Flash	Mode ¹	Green	Variable Speed Fan ON: 41 to 50%
6 Flash	Mode ¹	Green	Variable Speed Fan ON: 51 to 60%
7 Flash	Mode ¹	Green	Variable Speed Fan ON: 61 to 70%
8 Flash	Mode ¹	Green	Variable Speed Fan ON: 71 to 80%
9 Flash	Mode ¹	Green	Variable Speed Fan ON: 81 to 90%
10 Flash	Mode ¹	Green	Variable Speed Fan ON: 91 to 100%
Steady ON	Fault	Yellow	MCU Not Programmed
Steady ON	Fault	Red	MCU Hardware Failure
1 Flash	Fault	R-Y-G	Invalid Configuration
2 Flash	Fault	R-Y-G	Incompatible Software
1 Flash	Fault	R-Y	Base Board Communications Failure
Rapid Flash	Fault	Red	A2L Mitigation - Alarm Condition

NOTE 1: When the BACnet network is overriding the fan speed DIP switch selection, the LED interval color will be yellow instead of OFF.

Troubleshooting

MT2300 Unit Controller LED Faults

Microcontroller Not Programmed or Hardware Failure

LED Activity	Type	Color	Description
Steady ON	Fault	Red	Hardware Failure
Steady ON	Fault	Yellow	MCU Not Programmed

- Replace the controller.

Invalid Configuration

LED Activity	Type	Color	Description
1 Flash	Fault	R-Y-G	Invalid Configuration

- Verify configuration switch settings on both the main board and I/O expansion board. Configuration switch setting must be verified using the configuration switch setting outlined in this document, main board and I/O expansion board software must be compatible.

Incompatible Software

LED Activity	Type	Color	Description
2 Flash	Fault	R-Y-G	Incompatible Software

- Replace the controller.

I/O Expansion Board Communication Fail

LED Activity	Type	Color	Description
1 Flash	Fault	R-Y	I/O Exp Board Communications Fail

- Verify connection of 5 wire cable between H3 on the MT2300 main board and H3 on the MT2310 I/O expansion board is fully engaged in the connector.
- Confirm the low voltage supply is between 19-32VAC at the H1 terminal of the MT2310 I/O expansion board.
- Replace I/O expansion board.

Service Test Mode Enabled

LED Activity	Type	Color	Description
1 Flash	Mode	G-Y	Service / Test Mode Active

- Configuration switch SW1 is ON for test mode operation.

A2L Alarm – Refrigerant Leak

LED Activity	Type	Color	Description
Rapid Flash	Fault	Red	A2L Mitigation – Refrigerant Leak

- MT6210 mitigation controller has detected a A2L refrigerant leak.
- If no MT6210 mitigation controller is present, 5VDC is detected at H1-5 but 12VDC is not detected at H1-3 12V_ A2L input. Check connection at this terminal.
- Compressor and electric heat will be disabled and the fan will be forced to high speed during this alarm and for a minimum of 5 minutes after it has been resolved.

Compressor High Pressure

LED Activity	Type	Color	Description
1 Flash	Fault	Red	Compressor #1 High Pressure

- Verify high pressure switch is connected to terminal H7, pins 3 and 4 on the main board.
- Check for continuity of the high pressure switch.

If the high pressure fault resets when power is recycled:

- Check water flow (cooling operation)
- Check airflow (heating operation)
- Entering water and air temperatures should be within the operating limits.

Compressor Low Pressure

LED Activity	Type	Color	Description
2 Flash	Fault	Red	Compressor #1 Low Pressure

- Loose wire connection on low pressure circuit.
- Failed low pressure switch.
- Unit is low on charge.

Compressor Suction Temp Sensor Fail / Room Temp Sensor Fail (Room Sensor Control Only) / Leaving Water Temp Sensor Fail (FFD Units Only) / Return Air Sensor Failure (HGRH Units Only)

LED Activity	Type	Color	Description
3 Flash	Fault	Red	Compressor #1 Suction Temp Sensor Fail
5 Flash	Fault	Yellow	Leaving Water Temp Sensor Fail
8 Flash	Fault	Yellow	Space Temp Sensor Fail
9 Flash	Fault	Yellow	Return Air Temp Sensor Fail

- Check connection of low suction temperature sensor on terminal H2 pins 3 and 4.
- Check resistance of low suction temperature sensor, leaving water temperature sensor, room sensor, and return air sensor. All sensors are 10kohm thermistor at 77°F.

Compressor Low Suction Temp

LED Activity	Type	Color	Description
4 Flash	Fault	Red	Compressor #1 Low Suction Temp

- Check water flow (heating operation).
- Check airflow (cooling operation).
- Entering water and air temperatures should be within the operating limits.

A2L Alarm – Control Board Without Power

LED Activity	Type	Color	Description
9 Flash	Fault	Red	A2L Mitigation – Control Board Without Power

- MT6210 mitigation controller is not powered up. Check power connection to the MT6210 mitigation controller.
- If no MT6210 mitigation controller is present, 5VDC is not detected at H1-5 and 12VDC is not detected at H1-3 12V_ A2L input. Check connection at this terminal.

A2L Error – Refrigerant Sensor Fail

LED Activity	Type	Color	Description
Rapid Flash	Mode	Yellow	A2L Mitigation – Refrigerant Sensor Fail

- MT6210 mitigation controller has detected a A2L refrigerant sensor malfunction and one or more of the sensors need to be replaced.
- If the MT6210 does not indicated a A2L refrigerant sensor malfunction or no MT6210 mitigation controller is present, 5VDC is not detected at H1-5 but 12VDC is detected at H1-3 12V_A2L input. Check connection at this terminal.
- The fan will be forced to run at High Speed in this condition.

Low Voltage Brownout

LED Activity	Type	Color	Description
1 Flash	Fault	Yellow	Compressor Low Voltage Brownout

- Confirm the low voltage supply is between 19-32VAC at the H1 terminal of the MT2300 main board. If the low voltage supply is out of range, verify the unit supply voltage matches the nameplate voltage and the correct transformer primary wire has been selected.

Freeze Fault Detect

LED Activity	Type	Color	Description
2 Flash	Fault	Yellow	Freeze Fault Detect (FFD)

- Low leaving water temperature (below 35°F standard range or 13.5°F extended range)

Control Temp Sensor Failure

LED Activity	Type	Color	Description
3 Flash	Fault	Yellow	Control Temp Sensor Fail

- Room sensor control units only (MT2300 configuration switch SW6 is ON).
- Check connection of space temperature sensor on MT2300 terminal TB2 pins 4 (RM) and 5 (GND) and return air temperature sensor on MT2310 terminal H4 pins 3 (GND) and 4 (RAT).
- Check resistance of space sensor and return air sensor. All sensors are 10kohm thermistor at 77°F.

Entering Water Temp Sensor Fail (Boilerless Electric Heat, Hydronic Heat or Waterside Economizer Only)

LED Activity	Type	Color	Description
4 Flash	Fault	Yellow	Entering Water Temp Sensor Fail

- Check connection of entering water temperature sensor on MT2310 I/O expansion board terminal H4 pins 1 and 2.
- Check resistance of the entering water temperature sensor. All sensors are 10kohm thermistor at 77°F.

Leaving Water Temperature Sensor Failure

LED Activity	Type	Color	Description
5 Flash	Fault	Yellow	Leaving Water Temp Sensor Fail

- Freeze Fault Detect enabled (MT2300 configuration switch SW4 is ON).
- Check connection of leaving water temperature sensor on MT2300 terminal H2 pins 1 (LWT) and 2 (GND).
- Check resistance of leaving water temperature sensor. All sensors are 10kohm thermistor at 77°F.

Relative Humidity Sensor Failure

LED Activity	Type	Color	Description
6 Flash	Fault	Yellow	Relative Humidity Sensor Fail

- Relative Humidity Sensor Failure alarm has been enabled via network communications and the sensor is reporting out of range.
- Check connection of relative humidity sensor on MT2310 terminal TB1 pins 1 (REF) and 2 (RH).
- Check that relative humidity sensor has power.
- Check voltage output from relative humidity sensor (0-10VDC, 0-100% RH)

Condensate Overflow

LED Activity	Type	Color	Description
7 Flash	Fault	Yellow	Condensate Overflow

- Poor condensate drain.
- Check the resistance to ground on condensate wire. This should be open if there is no water in the pan.

Emergency Shutdown

LED Activity	Type	Color	Description
Rapid Flash	Mode	Green	Emergency Shutdown

- Verify the E terminal is not connected to common. Remove wire, if connected, and LED should change to solid green only (Occ, Bypass, Standby modes).

Occupied, Bypass, Standby Modes: Heating/ Cooling/Fan Only/Dehumidification

LED Activity	Type	Color	Description
1 Flash	Mode	Green	No Call for Heating / Cooling / Dehumidification
2 Flash	Mode	Green	Call for Cooling
3 Flash	Mode	Green	Call for Heating
4 Flash	Mode	Green	Call for Fan Only
6 Flash	Mode	Green	Call for Dehumidification

- Unit is operating normal. It may currently have a control signal or ready to operate when a control signal is active.

Unoccupied Mode

LED Activity	Type	Color	Description
5 Flash	Mode	Green	Unoccupied Mode Active

- Terminal U on main control board is connected to common from external source or commanded by network.

Low Entering Water Temperature (Heating) (No Display On Boilerless Electric Heat)

LED Activity	Type	Color	Description
7 Flash	Mode	Green	Low Entering Water Temp

- Verify entering water temperature is greater than set point.

HGR Low Return Air Temp Cutout

LED Activity	Type	Color	Description
8 Flash	Mode	Green	HGR Low Return Air Temp Cutout

- Unit is in the dehumidification mode and the return air temperature is below 68°F.

Waterside Economizer Low Temp Cutout (WSE Control & Call for Cooling)

LED Activity	Type	Color	Description
9 Flash	Mode	Green	WSE Low Temp Cutout

- Entering water temperature is below 45°F.

Troubleshooting the Water Source Heat Pump Unit

Compressor runs in short cycle

- Check wiring - loose or broken and check for faulty connection
- Check relays and contacts, also capacitor and wiring.
- Check high pressure switch, low pressure switch and low temperature switch to see if unit is cycling on the safety.
- Check to see if the reversing valve is not hung up and is operating correctly.
- Check condensate overflow switch in cool/dehumidification mode of operation.
- Check thermostat or room sensor for proper location

Neither fan, nor compressor runs and all LED lights are off

- Unit control, check thermostat for correct wiring or faulty thermostat.
- Wire may be loose or broken. Replace or tighten wires.
- Fuse may be blown, circuit breaker is open.
- Low voltage, check power supply voltage.

Fan operates, compressor does not

- For unit size 290, verify compressor protector fault status.
- Check wiring - loose or broken and check for bad connection.
- High or Low pressure lockout
 - a. Cool mode, check water flow
 - b. Heating mode, check air flow
 - c. Check reversing valve for proper valve position
- Check compressor overload - make sure it is closed.
- Check compressor to ground, or for internal short to ground.
- Compressor winding may be open. Check continuity with ohm meter.

Compressor attempts to start but does not

- Check compressor wiring for defective wiring or loose connection.
- Check for defective compressor internal windings with ohm meter.
- Check for faulty compressor capacitor.
- Check for lock rotor amp draw.

Insufficient cooling or heating

- Check thermostat for improper location.
- Check for proper air flow - filter could be dirty.
- Check blower assembly for dirt or faulty fan motor capacity.
- Check for low refrigerant charge.
- Check amp draw on blower assembly.
- Check for proper water flow and delta T (°F).

Start-Up

The MT2300 unit controller's valve or pump request terminal [IV/PR (H6)] is an output signal to external devices to allow water flow as required by the heat pump. The IV/PR (H6) terminal follows compressor operation inversely if connected to the normally open terminal and simultaneously when connected to the normally closed terminal. The IV/PR (H6) terminal can be used as a signal to an external pump or valve to enable flow to the unit. The compressor start is delayed for 60 seconds after the IV/PR (H6) output is energized.

Table 9: IV/PR(H6) terminal and compressor operation

IV/PR(H6)	Compressor On	Compressor Off
Normally Open	24 VAC	0 VAC
Normally Closed	0 VAC	24 VAC

Operation

Thermostat Inputs

Waterside Economizer/ Dehumidification

- The humidistat input (TB1-3, HST) on the I/O expansion board, when energized from the thermostat, enables Waterside Economizer or Dehumidification operation on units configured for one of the functions or the other.
- On units configured for both Waterside Economizer and Dehumidification, the humidistat input (TB1-3, HST) on the I/O expansion board, enables dehumidification and the Y1 input on the MT2300 baseboard (TB1-1), when energized from the thermostat, enables Waterside Economizer operation and the W4 input (TB1-5) on the MT2310 I/O expansion module will act as a Y3 third stage of cooling.

Electric Heat Controls

W3

The W3 (TB1-4) terminal in the MT2310 I/O expansion module enables the first stage of electric heat.

W4

The W4 (TB1-5) terminal on the MT2310 I/O expansion module enables the second stage of electric heat except on units configured for both Waterside Economizer and Dehumidification.

Supplemental Electric Heat Control

The supplemental electric heating option provides additional stages of heating that can be used in conjunction with compressor heating, or exclusively if the compressor is not available for heating.

General Rules

- Supplemental electric heater and the compressor may operate simultaneously.
- Minimum Compressor ON and OFF timers do not apply to electric heat control.

Operation

Fan Main Output: will turn ON and the Fan PWM signal will be at "Auxiliary Heat" duty cycle when:

- Any auxiliary heat output is energized.
- For 30 fixed seconds after all auxiliary heat outputs have been de-activated.

Electric Heat Outputs: are allowed to energize when either condition exists:

- Inter-Stage ON timer must be expired.
- Compressor is not available for heating.

When Compressor is Available

- Auxiliary Heat Stage #1 output energizes upon activation of Heating – Stage #3.
- Auxiliary Heat Stage #2 output energizes upon activation of Heating – Stage #4, except on units configured for both Waterside Economizer and Dehumidification.

When Compressor is Unavailable:

- Auxiliary Heat Stage #1 output energizes upon activation of "Heating – Stage #1.
- Auxiliary Heat Stage #2 output energizes upon activation of Heating – Stage #4, except on units configured for both Waterside Economizer and Dehumidification.

Boilerless Heat Control

- Turns on the heater when the entering water temperature is less than setpoint (default is 55°F), the temperature set point is adjustable through the network.
- For geothermal applications the heater turns on when the entering water temperature is less than setpoint (default 28°F).

NOTICE

In both cases, the compressor is shut down.

Heating Source Selection

Heating source selection provides a method to disable the compressor operation when in the heating mode.

Baseboard SW7 Configuration Switch operation

- OFF: Enables compressor operation in the heating mode.
- ON: Disables compressor operation in the heating mode.

When compressor operation is disabled in the heating mode and electric heat is available:

- Auxiliary Heat Stage #1: output energizes upon activation of the “Heating – Stage #1”.
- Auxiliary Heat Stage #2: output energizes upon activation of the “Heating – Stage #4”, except on units configured for both Waterside Economizer and Dehumidification.

When compressor operation is disabled in the heating mode electric and hydronic heat is unavailable:

- The unit will not provide any form of heating.

Hydronic Heat

General

The hydronic heating option provides control of a two position valve connected to a hot water coil when loop water temperature is warm enough for hydronic heating.

- Loop water temperature is sensed by a factory installed entering water temperature sensor located on the inlet water line.
- Hydronic heat circuit shall be independent and substitute the use of the compressor driven refrigeration circuit.

Operation

The Auxiliary Heat Stage #1 (H6-8) output on the MT2310 I/O expansion board is used to open the hydronic heating valve.

- Hydronic heating setpoint allowed range is 70°F to 158°F, with a 90°F default value.
- When Entering Water Temperature (EWT) rises above the hydronic heating on setpoint:
- Compressor will be locked out of heating (compressor minimum on timer applies).
- If hydronic heating is required: the pump request output is activated; the “wait for flow” timer is canceled because the EWT is adequate for hydronic heating; the hydronic heating output shall energize; and the fan will turn on 30 seconds after the hydronic heating output has been energized.
- The fan speed signal is based on the highest active heating stage (#1 or #2). Variable speed fan operates at the Hydronic Heat PWM speed.

Fan Speed Selection

The SW1-SW4 configuration switches on the MT2310 I/O expansion module allow CFM settings to be field adjustable with some fan options. Fan speed control optimizes unit fan speed based on thermostat/room sensor inputs.

The variable speed fan configuration switches allow for manually setting an optimal fan speed specific to the application requirements. The four primary speed profiles are selected using SW1 and SW2. SW3 reduces the heating and cooling speeds by 15%, and the SW4 switch selects the fan speed when in Fan Only mode (subject to the operational rules below).

Fan Only SW4

OFF = 20%

ON = Cool Stage 1 speed (Does not affect heat or cool mode fan speeds)

General Fan Operation Rules

50% minimum whenever heating or cooling

100% for Auxiliary Electric Heat

Hydronic heating/cooling = Heat Stage 1/Cool Stage 1

DEHUM = Cool Stage 1 minus 10% (50% minimum)

Table 10: I/O expansion module Configuration Switch

Fan Speed Row	Switch #1	Switch #2	Fan Only ¹	Cool Stage 1	Cool Stage 2	Heat Stage 1	Heat Stage 2
1	OFF	OFF	20%	80%	100%	80%	100%
2	ON	OFF	20%	70%	90%	70%	90%
3	OFF	ON	20%	60%	80%	60%	80%
4	ON	ON	20%	50%	70%	50%	70%

¹ See "Fan Only SW4" section above.

NOTE: Refer to [Figure 3](#) for configuration switch location.

BACnet Communication Module

On units with an optional BACnet communication module, fan speeds can be set through network communications to 1% resolution of duty cycle. For hydronic or compressorized modes, the range is 50-100%, and for fan only mode, the range is 10-100%. When enabled, the network fan speed settings will override the local configuration switches. When the MT2310 status LED interval is yellow instead of Off, this indicates that the network is overriding the fan speed settings.

Unit Options

Waterside Economizer

Application:

The MT2300 controls the waterside economizer. Upon a call for economizer operation via TB1-3, HST on the MT2310 I/O expansion board, for units without hot gas reheat or Y1 on the MT2300 baseboard for units with hot gas reheat), the output to the 3-way diverting valve and the fan motor are energized, allowing water flow through the economizer coil and fan operation.

Items Required

- Multi-stage thermostat or sensor

Unit Control Settings

- MT2310 I/O Expansion Module Jumper Settings:
 - SW8 = ON (WSE Enable)

Figure 10: Unit with WSE (no HGR) thermostat wiring diagram.

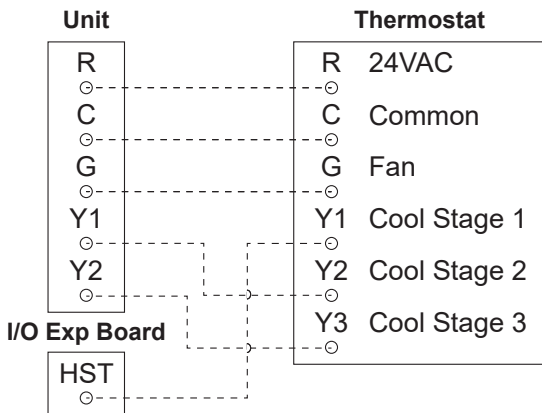
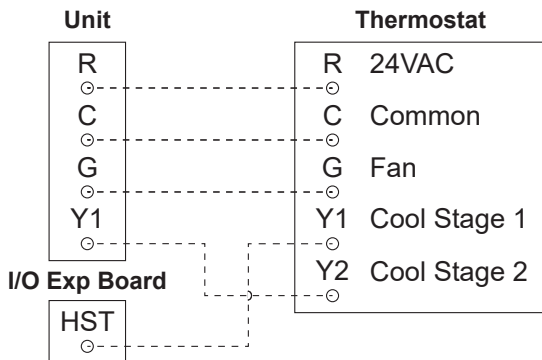

Figure 11: Unit with WSE (no HGR) thermostat wiring diagram.



Dehumidification

- Simplified Dehumidification
- Hot Gas Reheat Smart Dehumidification
- Humidistat Controlled Dehumidification
- Dehumidification Only

Simplified Dehumidification

Application

By utilizing a basic thermostat and configuring the MT2300 unit controller for this mode of operation, the WSHP will provide maximum latent capacity by optimizing blower fan speeds resulting in decreased humidity levels in the conditioned space.

Items Required

- Model SD, SN, ST, SL = 3 stage thermostat
- Model SC, SM, SS, SH, SR = 2 stage thermostat
- Return air sensor

NOTICE

This feature is not available if unit is controlled by a wall sensor.

Unit Control Settings

- MT2310 I/O Expansion Module Jumper Settings:
 - SW7 = ON (HGR Enabled)
 - SW8 = OFF (WSE Disable)

Wiring

Figure 12: Unit thermostat simplified dehumidification wiring diagram

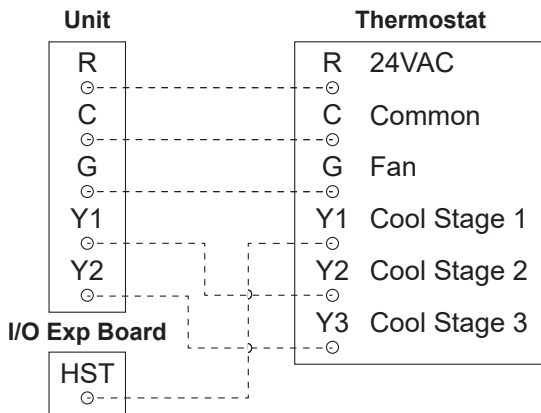
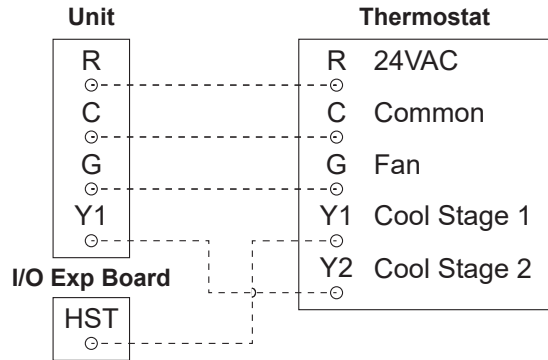

Figure 13: Unit thermostat simplified dehumidification wiring diagram



Operation

Unit will run at maximum compressor capacity with low CFM to maximize latent capacity.

Example: A 2-stage unit size 026, wired for Simplified Dehumidification:

- Upon a call for Y1, and the return air temperature is 68°F or greater. TB1-3, HST on the MT2310 I/O expansion board will be energized, allowing the compressor to operate at full load and the fan to operate at 600 CFM.
- Upon a call for Y2, Y1 on the unit control board will be energized, allowing the compressor to operate at part load and the fan to operate at 700 CFM. (Factory default fan speed setting #3)
- Upon a call for Y3, Y2 on the unit control board will be energized, allowing the compressor to operate at full load and the fan to operate at 800 CFM. (Factory default fan speed setting #3)

Hot Gas Reheat Smart Dehumidification

Application

By utilizing the factory installed hot gas reheat and smart air flow management; dehumidification can be achieved in applications where precise humidity control is required.

Items Required

- Unit with Hot Gas Reheat option
- Humidistat and a Thermostat OR Digitally Adjustable Wall Sensor
- Return air sensor

Unit Control Settings

- MT2310 I/O Expansion Module Jumper Settings:
 - SW7= ON (HGR Enabled)
 - SW8 = OFF (WSE Disabled)

Wiring

Figure 14: Thermostat and sensor combination hot gas reheat smart dehumidification wiring diagram

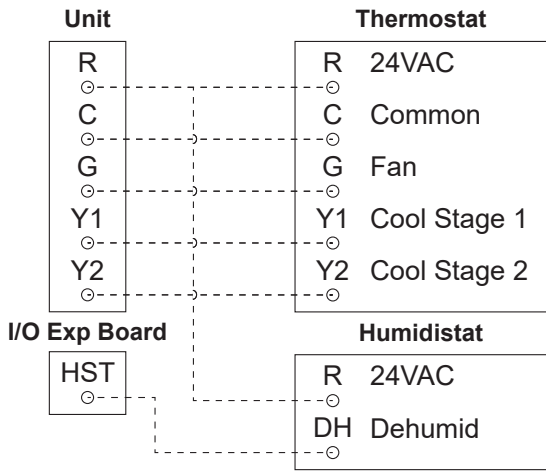
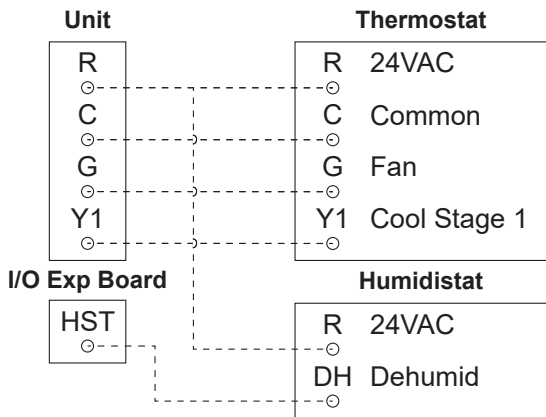

Figure 15: Thermostat and sensor combination hot gas reheat smart dehumidification wiring diagram



Operation

A call for heating or cooling has a higher priority than a call for dehumidification. Dehumidification is allowed only if the room temperature is satisfied and the return air temperature is 68°F or greater. If the controller detects the need for heating or cooling, or if the Humidistat is no longer calling for dehumidification, dehumidification mode will be suspended. Dehumidification mode will enable the 3-way hot gas bypass valve, sending hot superheated refrigerant to the hot gas reheat coil while running the compressor at full load and the fan at dehumidification speed.

NOTICE

See [Fan Performance](#) section in catalog for unit size specific fan speeds.

Figure 16: Unit with WSE and HGR thermostat Wiring Diagram

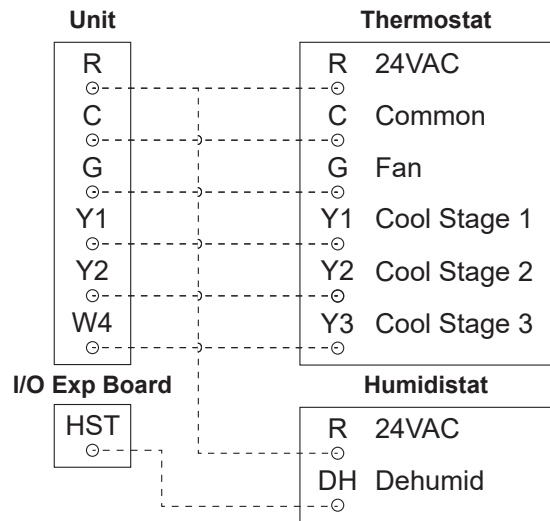

Figure 17: SmartSource MT2300 controller to digital room temperature sensor wiring

SmartSource Board	MT2300 Board								I/O Expansion Module	
Terminal Block Label	TB1-1	TB2-1	TB2-2	TB2-3	TB2-4	TB2-5	TB3-1	TB3-2	TB1-3	
Description	24VAC	Unit Status Output	Fan & Unit Mode	Setpoint Adjust	Room Temp Sensor & Tenant Override	DC Signal Common	Emergency Shutdown Input	Unoccupied Input	Dehumidification Input	
Terminal Label	R	LED	FM	SP	RM	GND	E	U	HST	
Typical Wiring	↕	↕	↕	↕	↕	↕	↗	↘	↖	
Terminal Label	R (24VAC)	1 (ST)	2 (FM)	3 (SP)	4 (UTS)	5 (GND)	6 (FC)	E	U	DH
Description	24VAC	Unit Status Output	Fan & Unit Mode	Setpoint Adjust	Room Temp Sensor & Tenant Override	DC Signal Common	Fan Speed Select - Fan Coil Version Only	Emergency Shutdown	Unoccupied	Dehumidification
Sensor	Digitally Adjustable Room Temperature Sensor (Part No. 910121754)									

Humidistat Controlled Dehumidification

Application

Similar to the simplified dehumidification option, this option also maximizes latent capacity by using a humidistat and thermostat. This option allows the room thermostat to control sensible cooling, while the independent humidistat controls room humidity levels

Items Required

- Humidistat combined with a...
- Model SD, SN, ST, SL = 3 stage thermostat
- Model SC, SM, SS, SH, SR = 2 stage thermostat
- Return air sensor

NOTE: This feature is not available if unit is controlled by wall sensor

Unit Control Settings

- MT2310 I/O Expansion Module Jumper Settings:
 - SW7 = ON (HGR Enabled)
 - SW8 = OFF (WSE Disabled)

Wiring

- Thermostat/Sensor combination:
- Field supplied sensor

Figure 18: Unit thermostat and humidistat combination - humidistat controlled dehumidification wiring diagram

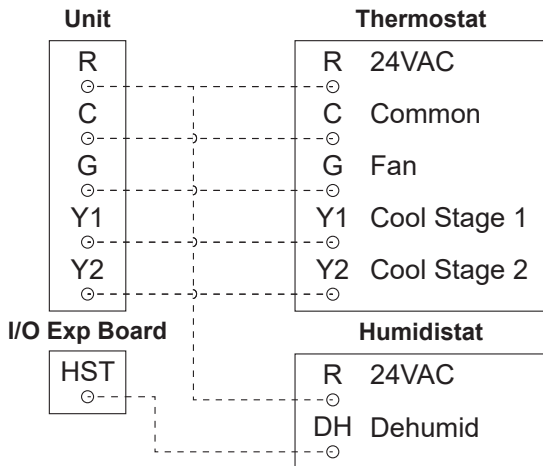

Figure 19: Unit thermostat and humidistat combination - humidistat controlled dehumidification wiring diagram

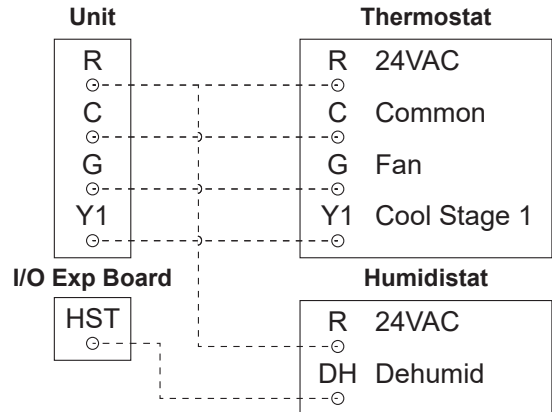

Figure 20: SmartSource MT2300 controller & I/O expansion module to field supplied return air temperature sensor and humidistat wiring

SmartSource Board	MT2300 Board		MT2300 Board	
Terminal Block Label	H4-3	H4-4	TB1-3	TB1-6
Description	Sensor Common	Return Air Temperature	Dehumidification Input	Humidistat Source Voltage (24VAC)
Terminal Label	GND	RAT	HST	R
Typical Wiring	↑ ↓ ↑ ↓ ↑ ↓ ↑ ↓			
Terminal Label	X	X	X	X
Description	DC Signal Common	Room Temp Sensor, 10K Ohm ATP Curve Z or equivalent	Dehumidification Output	Dehumidification Source Voltage
Sensor	Field Supplied Room Temperature Sensor			

Operation

- A call for heating or cooling has a higher priority than a call for dehumidification. Dehumidification is allowed only if the room temperature is satisfied and the return air temperature is 68°F or greater.
- If the controller detects the need for heating or cooling, or if the Humidistat is no longer calling for dehumidification, dehumidification mode will be suspended.
- Dehumidification mode will enable the 3-way hot gas bypass valve, sending hot superheated refrigerant to the hot gas reheat coil while running the compressor at full load and the fan at dehumidification speed.

NOTICE

See [Fan Performance](#) section in catalog for unit size specific fan speeds.

Dehumidification Only

Application

In applications where only dehumidification is needed, the humidistat can be wired to HST on the MT2300 unit controller, allowing the WSHP unit to operate in dehumidification mode only. The unit will only respond to a call for dehumidification whenever the return air temperature is 68°F or greater.

Items Required

- Humidistat
- Return air sensor

Unit Control Settings

- I/O Expansion Module Jumper Settings:
 - SW7 = ON (HGR Enabled)
 - SW8 = OFF (WSE Disabled)

Wiring

Figure 21: Unit and humidistat-dehumidification only wiring diagram

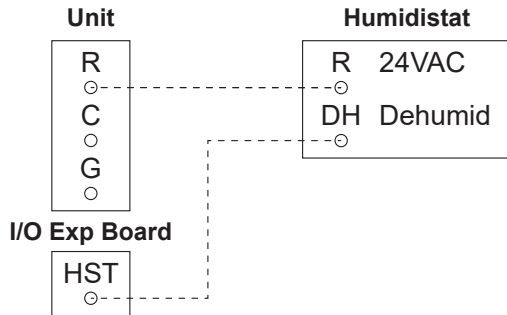

Operation

Upon a call for dehumidification, the unit will run in Cool Stage 1 compressor capacity and Dehumidification fan speed.

Example

A 2-stage model SD, unit size 026, wired for Dehumidification Only:

- Upon a call for dehumidification from the humidistat, HST on the unit control board will be energized, allowing the compressor to operate at full load and the fan to operate at dehumidification CFM.

NOTICE

See Fan Performance section in catalog for unit size specific fan speeds.

Analog Humidity Sensor Input

- Any of the dehumidification options described can also be used with an optional 0-10VDC relative humidity sensor.
- An analog humidity sensor is intended to be an option for units with BACnet communications to allow the relative humidity value to be viewed and the dehumidification setpoint to be adjusted via network communications.
- When an analog humidity sensor is used, and optional Humidity Sensor Failure alarm can be configured to indicate if the sensor reading has become unreliable. The Sensor Failure Alarm feature is disabled by default, and can be activated via network communications.
- While an analog humidity sensor can be used on units without network communications, there will be no way to the relative humidity or adjust the relative humidity setpoint, so a humidistat is recommended.

Figure 22: Analog Humidity Sensor Wiring

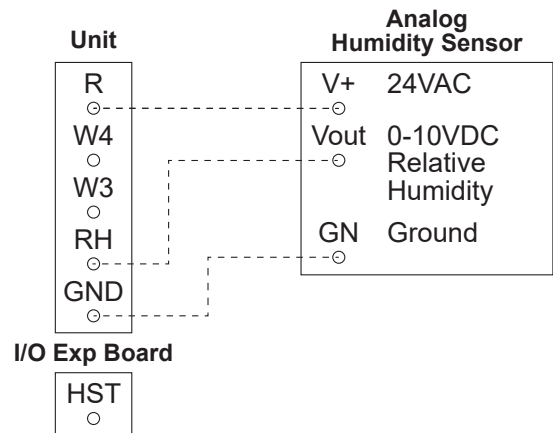

Controls

MT2300 Controller with an Optional BACnet® Communication Module



For installation and operation information on MT2300 unit controller and other ancillary components, see:

- IM 955 - MicroTech III Wall Sensor For use with Microtech III Unit Controller
- IM 1363 - MicroTech MT2300 Water Source Heat Pump Unit Controller BACnet® MS/TP Network Integration
- ED 19129 - MicroTech MT2300 Water Source Heat Pump Unit Controller BACnet® Protocol Information

Daikin water source heat pumps are available with an optional BACnet MS/TP communication module that is designed to communicate over a BACnet MS/TP communications network to a building automation system (BAS). It can be factory or field-installed.

The unit controller is programmed and tested with all the logic required to monitor and control the unit. An optional wall sensor may be used with the communication module to provide limited local control of the water source heat pump. The unit controller monitors water and air temperatures and passes information to the communication module. The module communicates with the BAS, to provide network control of the water source heat pump.

The module makes operational data and commands available on a communications network using BACnet objects and properties:

- The network cable is a shielded twisted-pair cable
- Network communications run up to 76.8 Kbps
- DIP switches on the controller enable the MS/TP MAC address to be set in the range 0-127
- Four green status LEDs on the communication module indicate communication activity on the MS/TP communication network and with the unit controller

Figure 23: MT2300 BACnet MS/TP Snap-in Communication Module

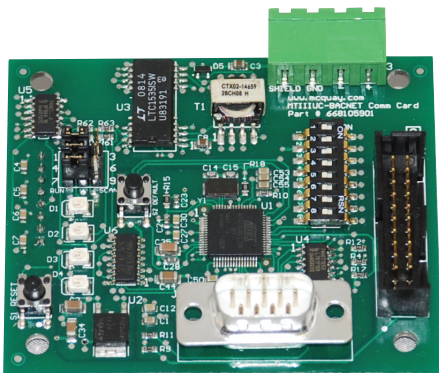

MT2300 Unit Controller with BACnet MS/TP Communication Module orchestrates the following unit operations

- Enable heating and cooling to maintain setpoint based on a room sensor
- Enable fan and compressor operation
- Monitors all equipment protection controls
- Monitors room and discharge air temperatures
- Monitors leaving water temperature
- Relays status of all vital unit functions

The MT2300 unit controller with an optional communication module includes

- Return Air Temperature sensor (RAT)(field-installed)
- Discharge Air Temperature sensor (DAT)(field-installed)
- Leaving Water Temperature sensor (LWT)

NOTICE

Refer to IM 956-X for details to install (RAT) & (DAT) sensors.

WARNING

When an optional wall-mounted room temperature sensor is connected to the unit controller, the Return Air Temperature (RAT) sensor must not be installed. A wall-mounted room temperature sensor and the return air temperature sensor must not be connected simultaneously or the unit will not operate properly.

The communication module provides access to setpoints for operational control

Available wall sensors include:

- Room sensor with LED status and tenant override button
- Room sensor with LED status, tenant override button, and ±5°F setpoint adjustment
- Room sensor with LED status, tenant override button, 55° to 95°F setpoint adjustment

COMPLETE HVAC SYSTEM SOLUTIONS

SELF-CONTAINED | ROOFTOPS | COILS | CONDENSING UNITS
AIR HANDLERS | WATER-COOLED CHILLERS | AIR-COOLED CHILLERS
MODULAR CENTRAL PLANTS | SITELINE BUILDING CONTROLS
UNIT HEATERS | FAN COILS | AIR PURIFIERS | WATER SOURCE HEAT PUMPS
VARIABLE AIR VOLUME UNITS | UNIT VENTILATORS



13600 INDUSTRIAL PARK BLVD. | MINNEAPOLIS, MN 55441
1-800-432-1342 | 763-553-5330

LEARN MORE AT
DAIKINAPPLIED.COM

PART NUMBER: OM1364

© 2024 DAIKIN APPLIED | (800) 432.1342 | WWW.DAIKINAPPLIED.COM