



Operations Manual

OM 1329

Group: Applied Air Systems

Part Number: OM 1329

Date: August, 2022

Vision®/Skyline® EC Fan Array with MicroTech® 4 Fan Controller

Models: CAH, CAC, OAH, OAC



Table of Contents

VISION/SKYLINE INTRODUCTION	4
CONTROL PANEL LOCATIONS.....	4
MICROTECH 4 FUNDAMENTALS.....	6
Getting Started	6
Passwords.....	6
Navigation Mode.....	7
Edit Mode	7
KEYPAD AND DISPLAY MENU STRUCTURE	8
CONNECTION FIELD WIRED INPUTS.....	12
Field Control Wiring.....	12
Fan Array Sensors.....	16
Duct Pressure Sensor.....	16
Ready Relay	16
Running Relay.....	16
Alarm Output.....	17
COMMISSIONING AND OPERATIONS.....	17
Unit Set-Up	17
Unit Set-Up Menu:	17
Date/Time Settings.....	17
Date/Time Menu:	18
ENABLE THE UNIT.....	18
Configure Unit Menu.....	18
Control Mode	18
Digital Inputs	18
Fan Tracking Menu	19
CFM Sensor Setup	20
CONFIGURE FANS MENU.....	21
QUICK MENU	22
UNIT STATUS	23
VIEW STATUS.....	23
FAN STATUS.....	24
Fan Menus	24
Alarm Status	25
Warn Status	25
OTHER CONFIGURATIONS.....	26

Damper Control.....	26
Manual Array Operation	27
BMS COMMUNICATIONS	27
BACnet IP Set-Up.....	27
BACnet MSTP Set-Up.....	28
SERVICE MENUS	28
Fan Service.....	28
Operating Hours Menu.....	28
Modbus.....	29
Air Flow.....	30
DSP Control.....	30
CFM Control.....	30
UNIT MAINTENANCE	31
ALARMS	31
Viewing Alarms.....	31
OTHER MENU ITEMS	31
About This Unit.....	31
MICROTECH 4 INPUTS/OUTPUTS	32
Main Control Board	32
APPENDIX	33
Modbus I/O	33

VISION/SKYLINE INTRODUCTION

This manual provides operating information about the Vision/Skyline Daikin EC Fan array with premium controls. This document includes controller operation sequences and start-up procedures. For overall unit installation and/or maintenance procedures, refer to the following IMs:

- Vision CAC/CAH – IM 672
- Vision Extended Sizes CAC/CAH – IM 915
- Skyline OAC/OAH – IM 777
- Non-Daikin: See vendor manuals



Example Delta Motor Label

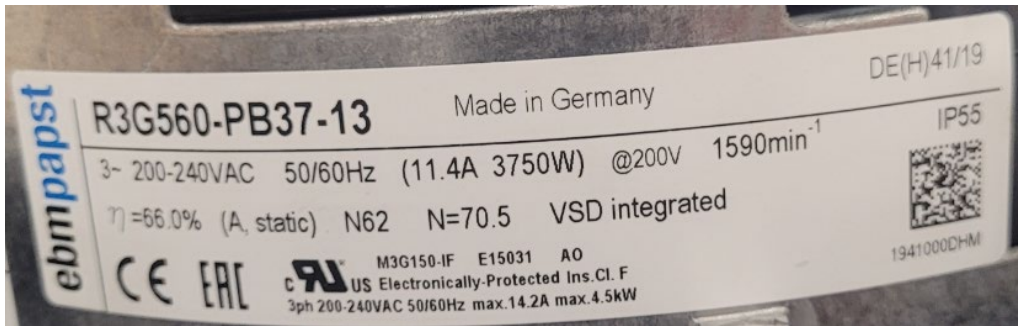

Figure 1: Example Motor Labels

CONTROL PANEL LOCATIONS

Figure 2 shows control and power panel locations on a typical section. Figures 3 and 4 show the layout of the components within the power box and low voltage control box, respectively.

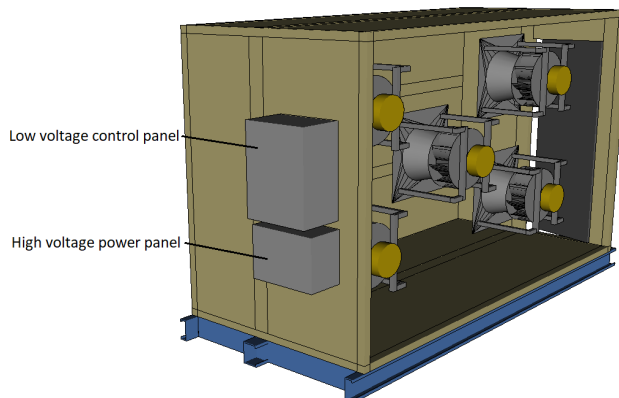

Figure 1: Panels Location Example

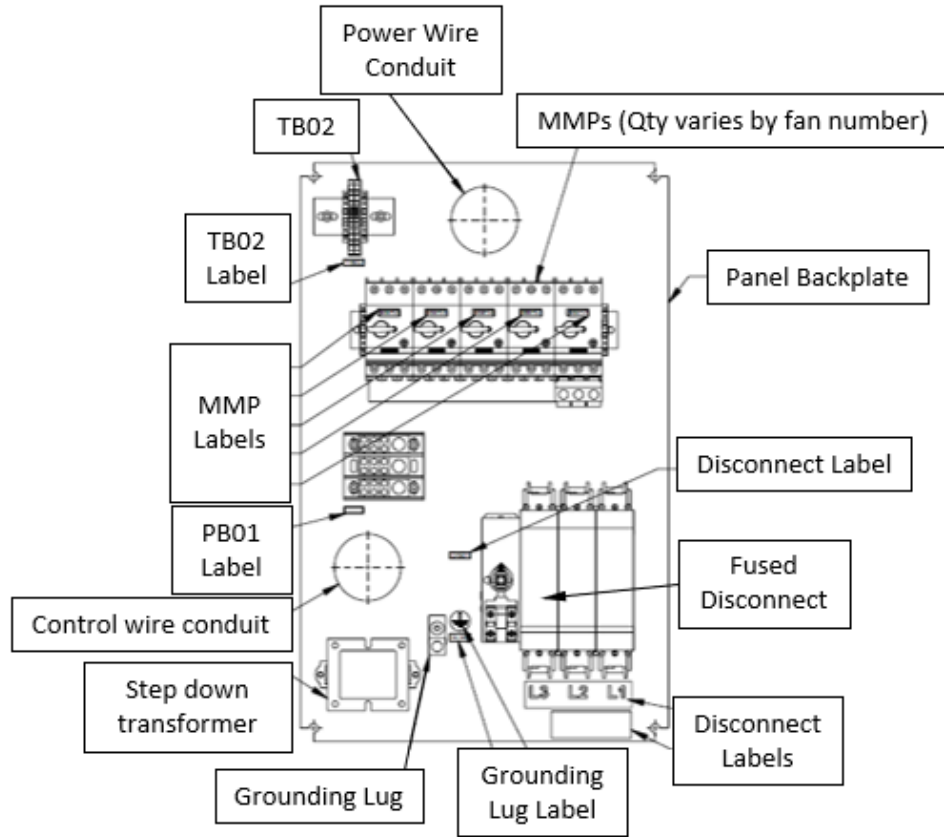

Figure 3: Example Power Box Control Panel

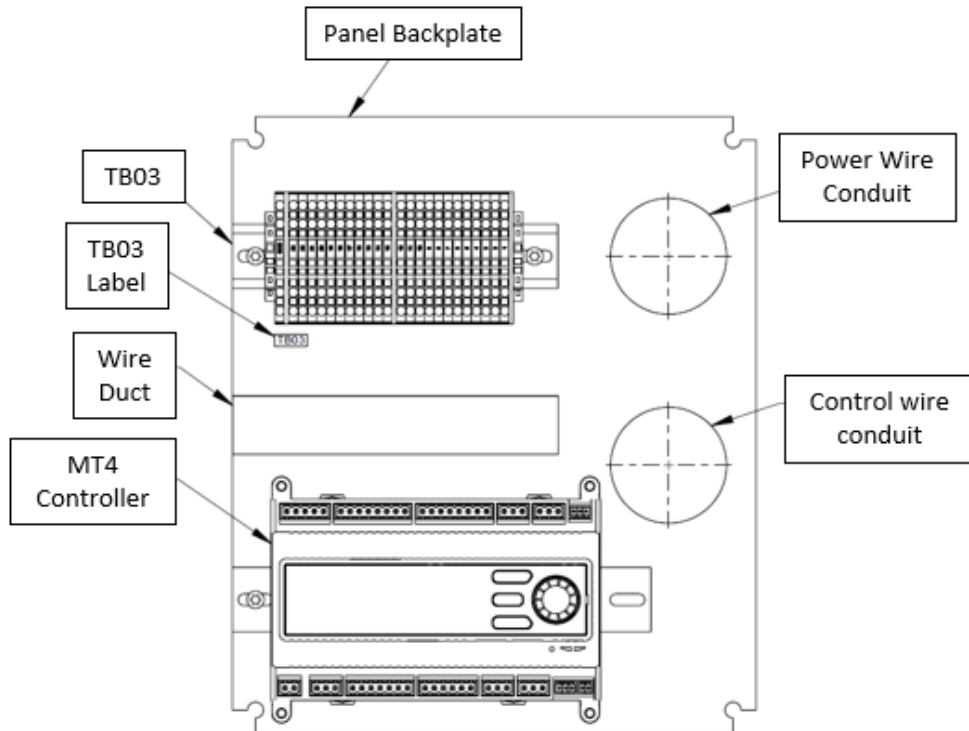

Figure 4: Example Low Voltage Control Panel

MICROTECH 4 FUNDAMENTALS

Getting Started

This manual contains information designed to assist the field technician with the Daikin EC fan array setup when premium controls are provided. The technician will need to be familiar with the following topics at a minimum to successfully set up the Daikin EC fan array operation.

- Keypad navigation/editing/passwords
- Control Mode
- Demand Source

The keypad/display consists of a 5 line by 22-character display, three keys and a “push and roll” navigation wheel. There is an Alarm Button, Menu (Home) Button, and a Back Button. The wheel is used to navigate between lines on a screen (page) and to increase and decrease changeable values when editing. Pushing the wheel acts as an Enter Button.

The first line on each page includes the page title and the line number to which the cursor is currently “pointing”. The line numbers are X/Y to indicate line number X of a total of Y lines for that page. The left most position of the title line includes an “up” arrow to indicate there are pages “above” the currently displayed items, a “down” arrow to indicate there are pages “below” the currently displayed items or an “up/down” arrow to indicate there are pages “above and below” the currently displayed page.

Each line on a page can contain status only information or include changeable data fields. When a line contains status only information and the cursor is on that line all but the value field of that line is highlighted meaning the text is white with a black box around it. When the line contains a changeable value and the cursor is at that line, the entire line is highlighted. Each line on a page may also be defined as a “jump” line, meaning pushing the navigation wheel will cause a “jump” to a new page. An arrow is displayed to the far right of the line to indicate it is a “jump” line and the entire line is highlighted when the cursor is on that line.

The keypad/display Information is organized into Menu groups; Main Menu, Quick Menu, View Status, Commission Unit, Manual Control, Service Menus, BMS Communications, Alarm List, and About This Unit.

NOTE: Only menus and items that are applicable to the specific unit configuration are displayed.

The Main Menu allows the user to enter a password, access the Quick Menu pages, view the current unit state, access the Alarm List Menu as well as access information about the fan array. The Quick Menu provides access to status information indicating the current operating condition of the fan array. The View Status Menus include basic fan array operating status menus and information about current operation. The Commission Unit menu includes commissioning/configuration menus to set up the fan array for operation. The Manual Control Menu allows service personnel to test fan array operation directly from the HMI. The Service Menus allow service personnel to review Modbus status and current fan operation hours. The BMS Communications menus allow service personnel to view and set building management system parameters such as the IP address. The Alarm List Menu includes active alarm and alarm log information. The About This Unit menu allows service personnel to view information about the fan array including SO Number and Software Build Version.

Passwords

Various menu functions are accessible or inaccessible, depending on the access level of the user, and the password they enter, if any. There are four access levels, including no password, Level 2, Level 4, and Level 6, with Level 2 having the highest level of access. Without entering a password, the user has access only to basic status menu items. Entering the Level 6 password (5321) allows access to the Alarm Lists Menu, Quick Menu, and the View Status Unit Menus group. Entering the Level 4 password (2526) allows similar access as Level 6 with the addition of the Commission Unit Menu, Manual Control, and Service Menu groups. Entering the Level 2 password (6363) allows similar access as Level 4 with the addition of the Unit Configuration Menu.

NOTE: Alarms can be acknowledged without entering a password.

The main password page is displayed when the keypad/display is first accessed, the Home Key is pressed, the Back Key is pressed multiple times, or if the keypad/display has been idle longer than the Password Timeout (default 10 minutes). The main password page provides access to enter a password, access the Quick Menu, view the current Unit State, access the alarm lists or view information about the unit.

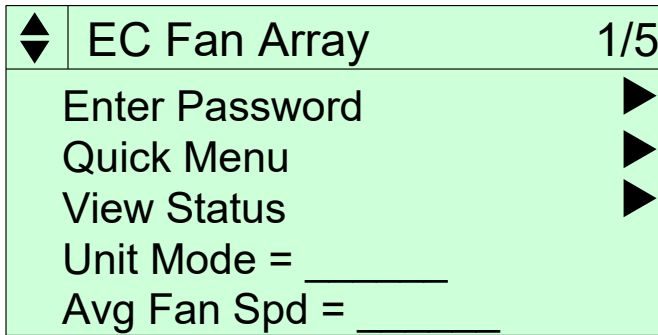

Figure 5: Password Main Page

The password field initially has a value **** where each * represents an adjustable field. These values can be changed by entering the Edit Mode described below.

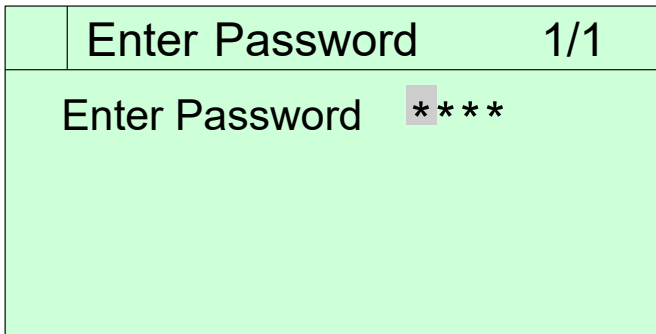

Figure 6: Password Entry Page

Entering an invalid password has the same effect as continuing without entering a password. Once a valid password has been entered, the controller allows further changes and access without requiring the user to enter a password until either the password timer expires or a different password is entered. The default value for this password timer is 10 minutes.

Navigation Mode

In the Navigation Mode, when a line on a page contains no editable fields, all but the value field of that line is highlighted, meaning the text is white with a black box around it. When the line contains an editable value field the entire line is inverted when the cursor is pointing to that line.

When the navigation wheel is turned clockwise, the cursor moves to the next line (down) on the page. When the wheel is turned counterclockwise the cursor moves to the previous line (up) on the page. The faster the wheel is turned the faster the cursor moves.

When the Back Button is pressed the display reverts to the previously displayed page. If the Back button is repeatedly pressed the display continues to revert one page back along the current navigation path until the “main menu” is reached.

When the Menu (Home) Button is pressed the display reverts to the “main page.”

When the Alarm Button is depressed, the Alarm Lists menu is displayed.

Edit Mode

The Editing Mode is entered by pressing the navigation wheel while the cursor is pointing to a line containing an editable field. Once in the edit mode pressing the wheel again causes the editable field to be highlighted. Turning the wheel clockwise while the

editable field is highlighted causes the value to be increased. Turning the wheel counterclockwise while the editable field is highlighted causes the value to be decreased. The faster the wheel is turned the faster the value is increased or decreased. Pressing the wheel again cause the new value to be saved and the keypad/display to leave the edit mode and return to the navigation mode

KEYPAD AND DISPLAY MENU STRUCTURE

The following is a description of the Vision/Skyline Fan-Only Controller menu structure. These menus and items can all be viewed on the keypad/display. Menu items displayed will change based on the unit configuration.

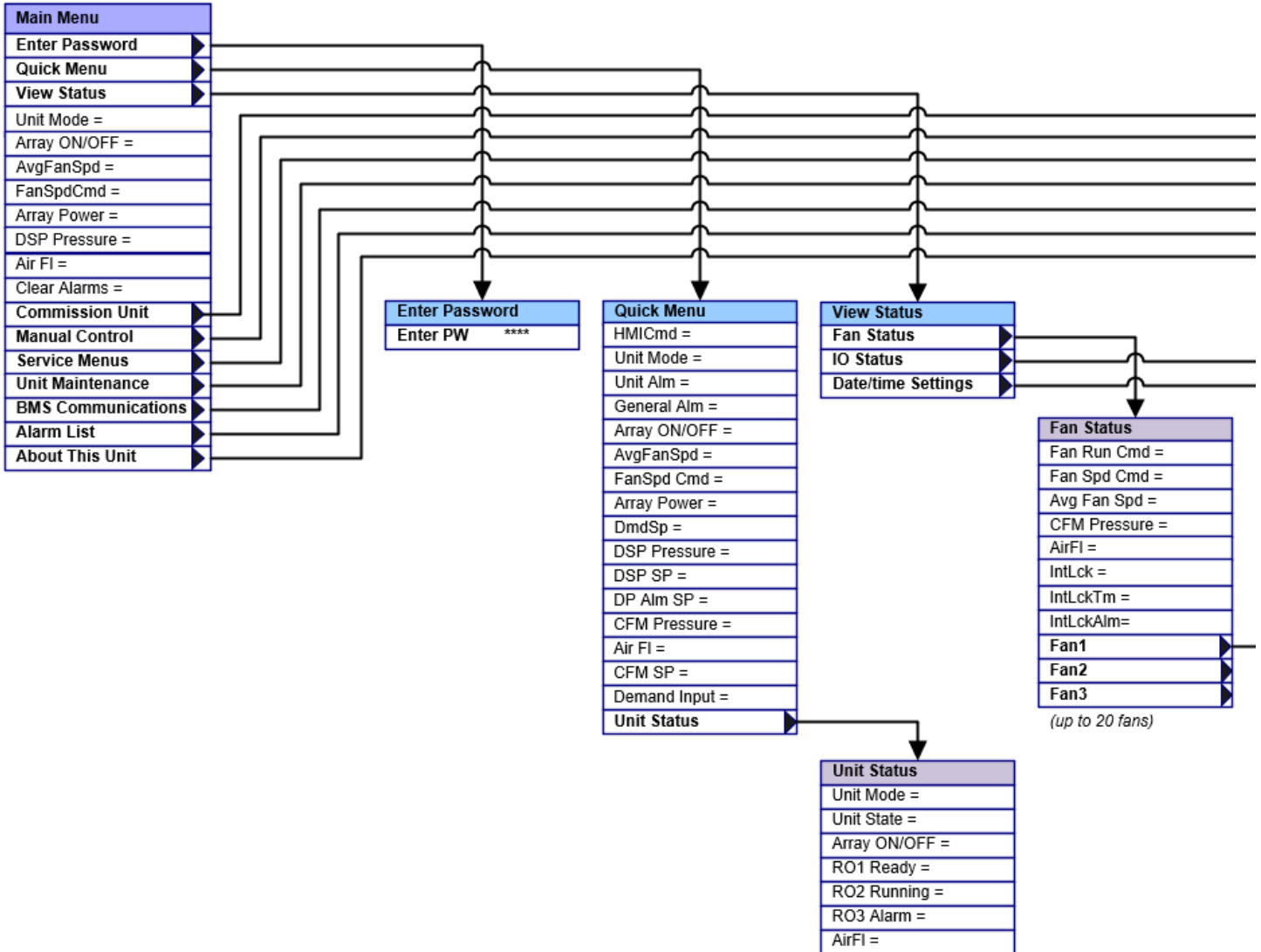

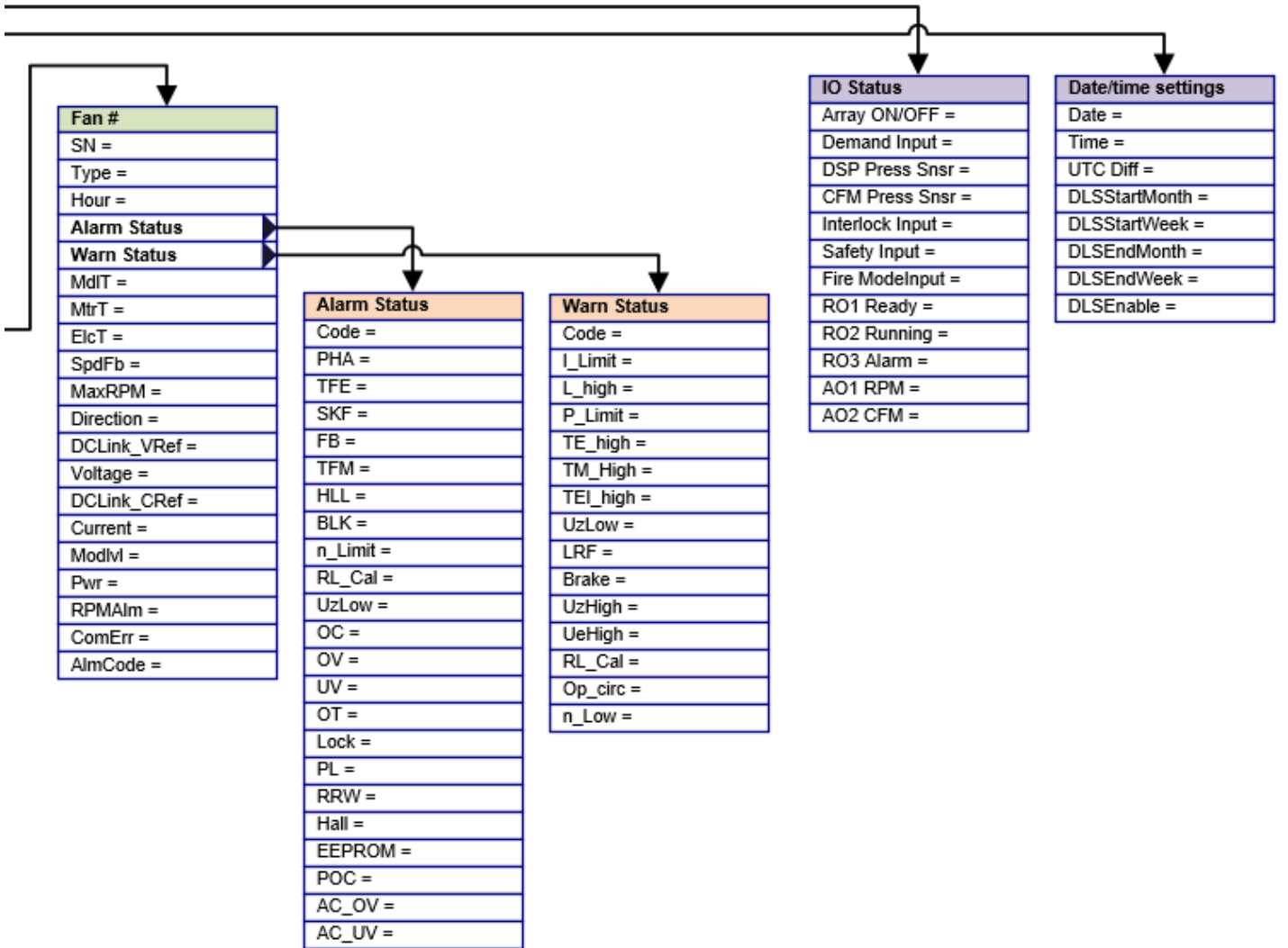

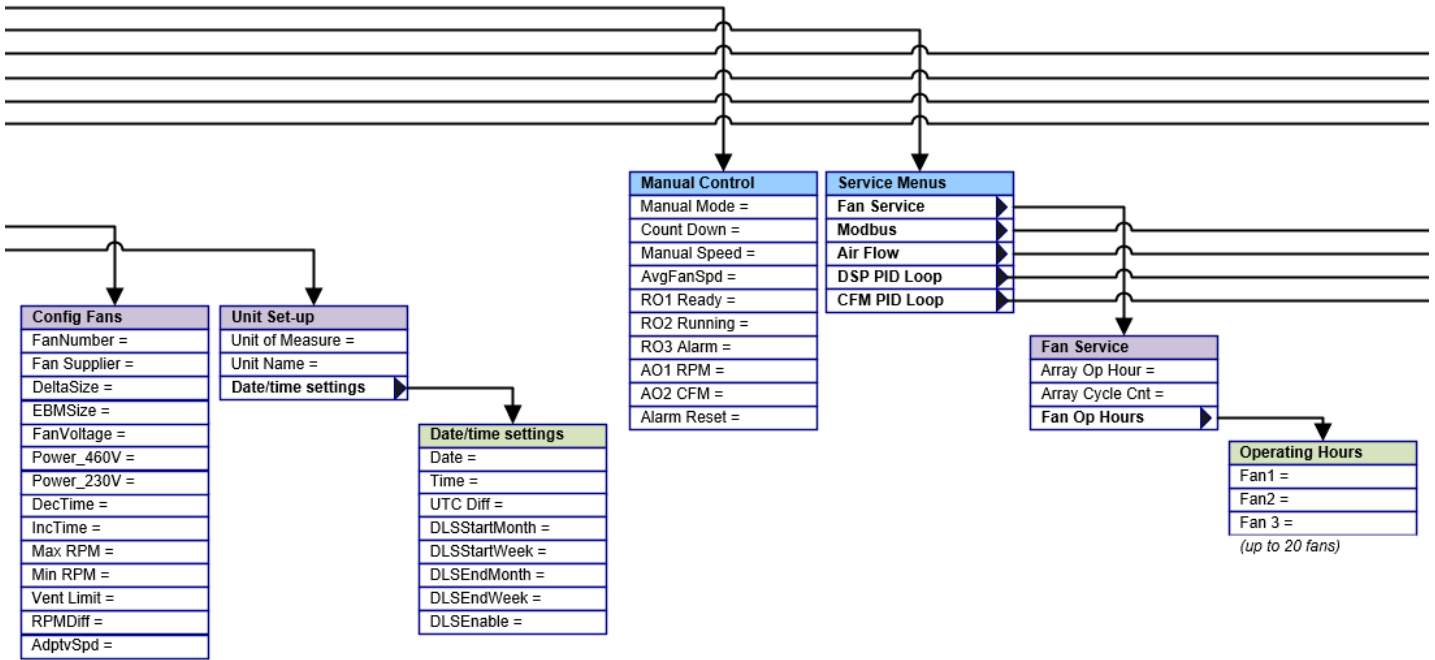
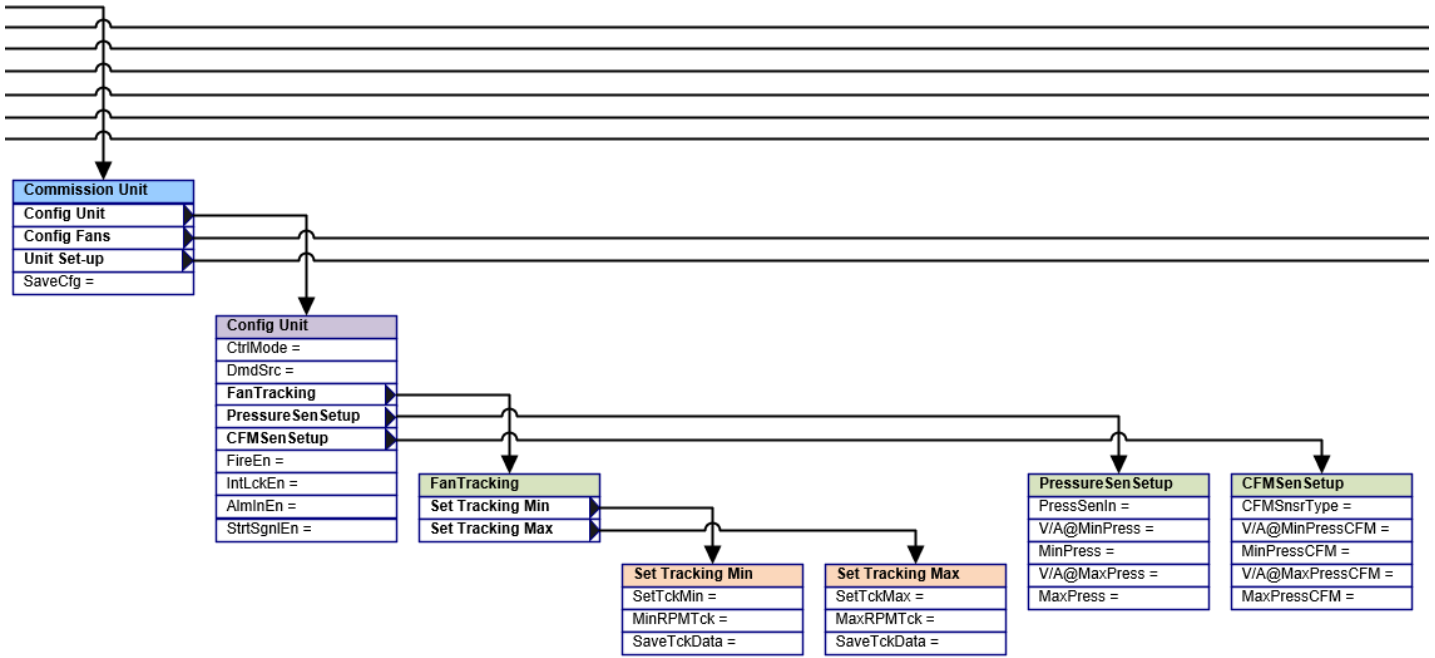

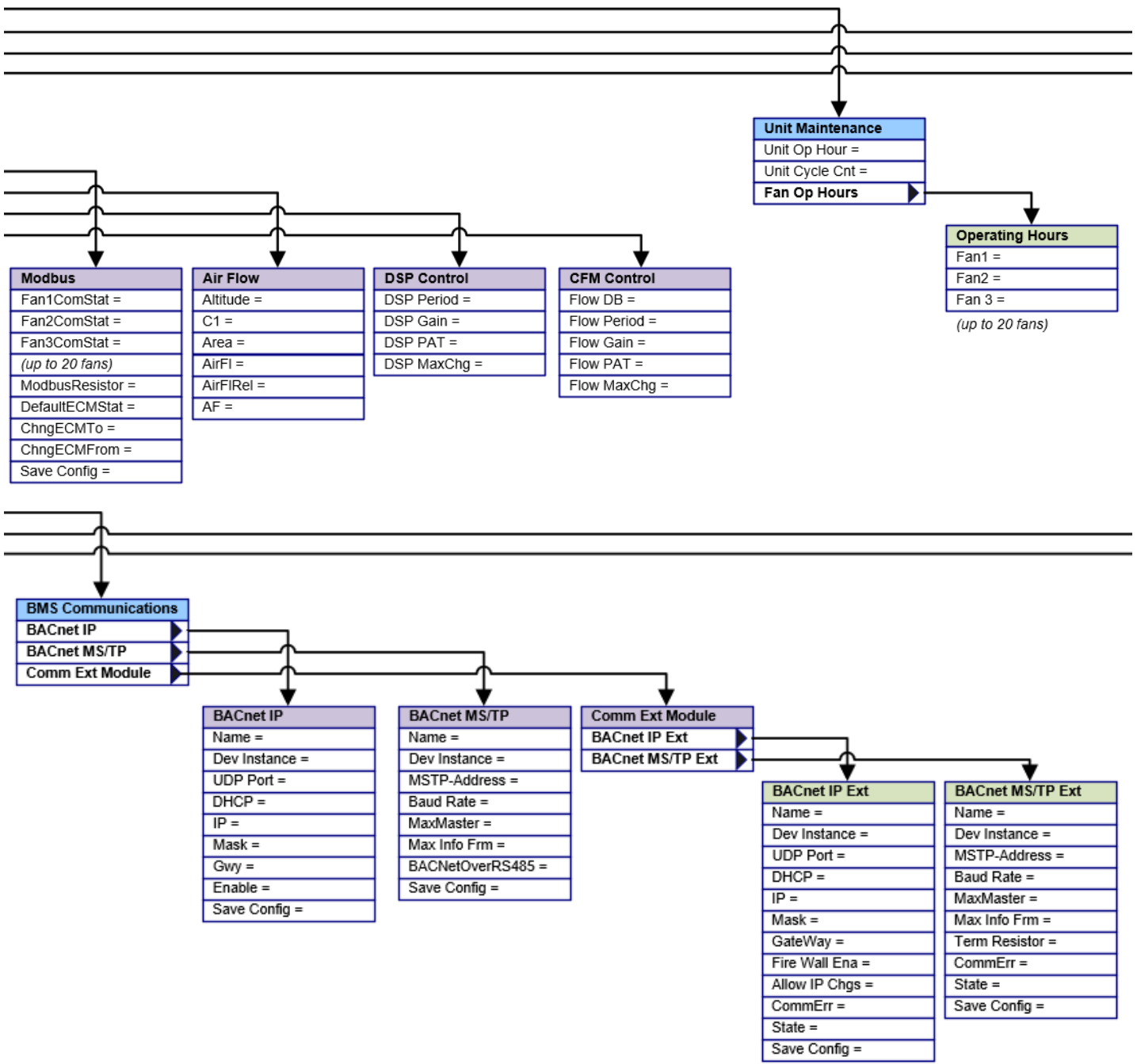

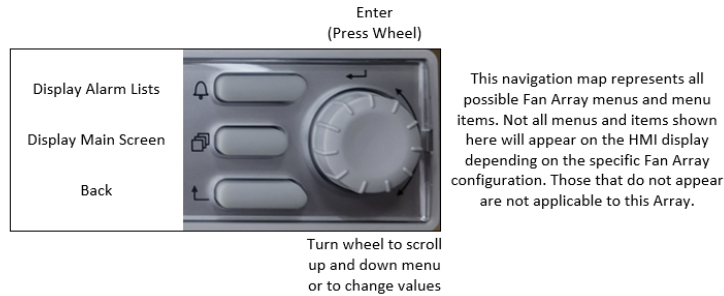
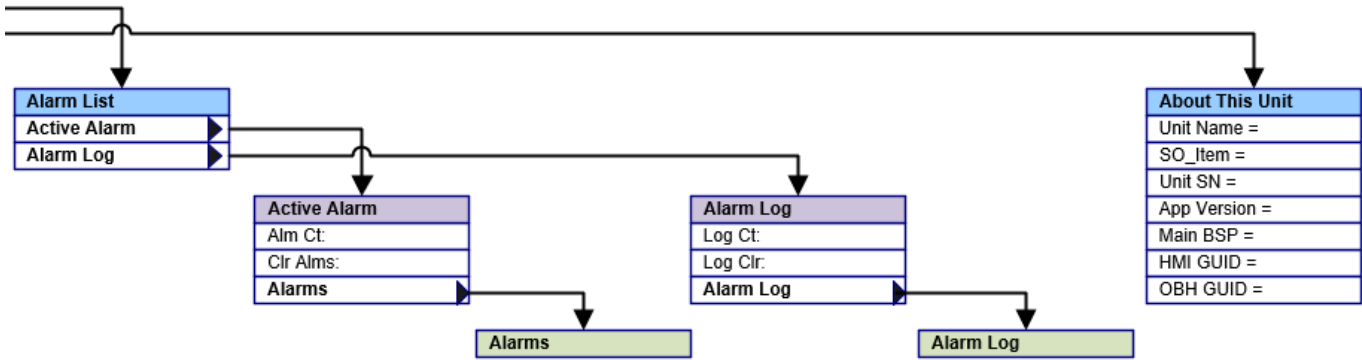

CONNECTION FIELD WIRED INPUTS

Field Control Wiring

After the unit has been installed, EC Fan Arrays may require low voltage field wiring to connect the BMS to the MicroTech 4 fan controller, along with any additional sensors that may be required. Use the schematic provided on the door of the control panel to determine where field control connections required for the application are located. Figure 7 is a graphical representation of TB03, and Table 1 shows the possible field connections that can be made.

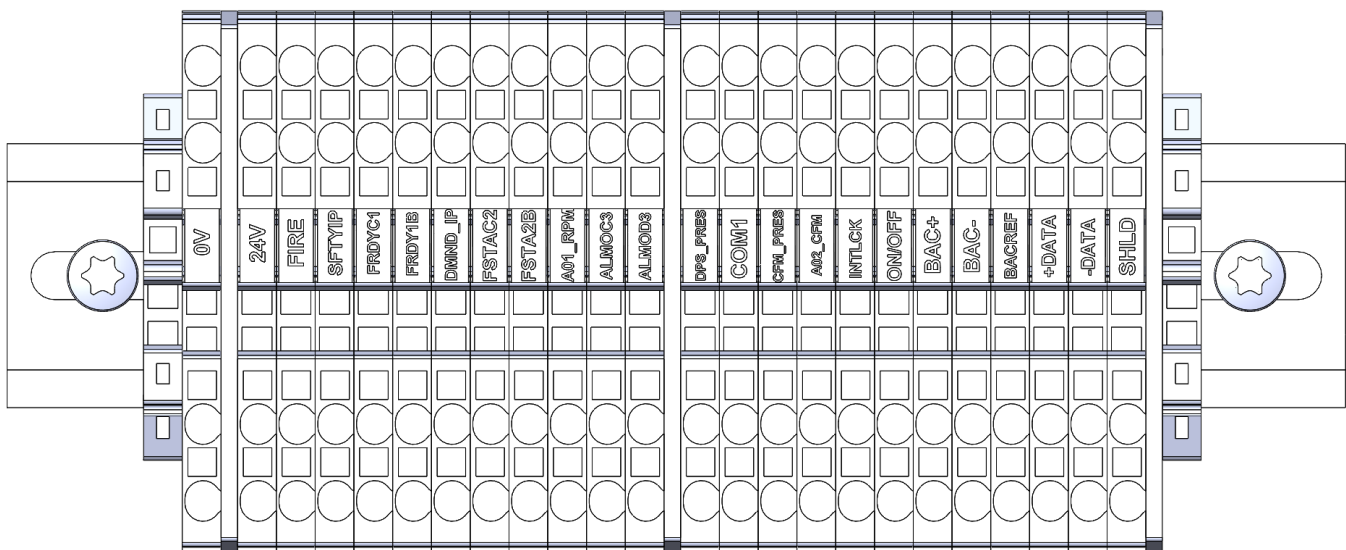

Figure 7: Graphical representation of TB03

Table 1: Potential Field Connections and Locations on TB03 (Terminal Block Label 1 is Rightmost Terminal Block)

Terminal Block Label	Terminal Block Name	Description	Signal
1	SHLD	MODBUS to Fans	RS485
2	-DATA	MODBUS to Fans	RS485
3	+DATA	MODBUS to Fans	RS485
4	BACREF	BACnet Ground	RS485
5	BAC-	BACnet Negative	RS485
6	BAC+	BACnet Positive	RS485
7	ON/OFF	Array ON/OFF	Contact Closure
8	INTLCK	Interlock Input	Contact Closure
9	A02_CFM	CFM Output	0-10V DC
10	CFM_PRES	CFM Pressure Sensor	Configurable (4-20mA/0-10V)
11	COM1	DC Ground	GND
12	DPS_PRES	DSP Pressure Sensor	Configurable (4-20mA/0-10V)
13	ALMOD3	Alarm	Contact Closure
14	ALMOC3	Alarm	Contact Closure
15	A01_RPM	RPM Output	0-10V DC
16	FSTA2B	Fan Status	Contact Closure
17	FSTAC2	Fan Status	Contact Closure
18	DMND_IP	Demand Input	Contact Closure
19	FRDY1B	Fan Ready	Contact Closure
20	FRDYC1	Fan Ready	Contact Closure
21	SFTYIP	Safety Input	Contact Closure
22	FIRE	Fire Mode Input	Contact Closure
23	24V	Power Supply	24V
GROUND	0V	GND	GND

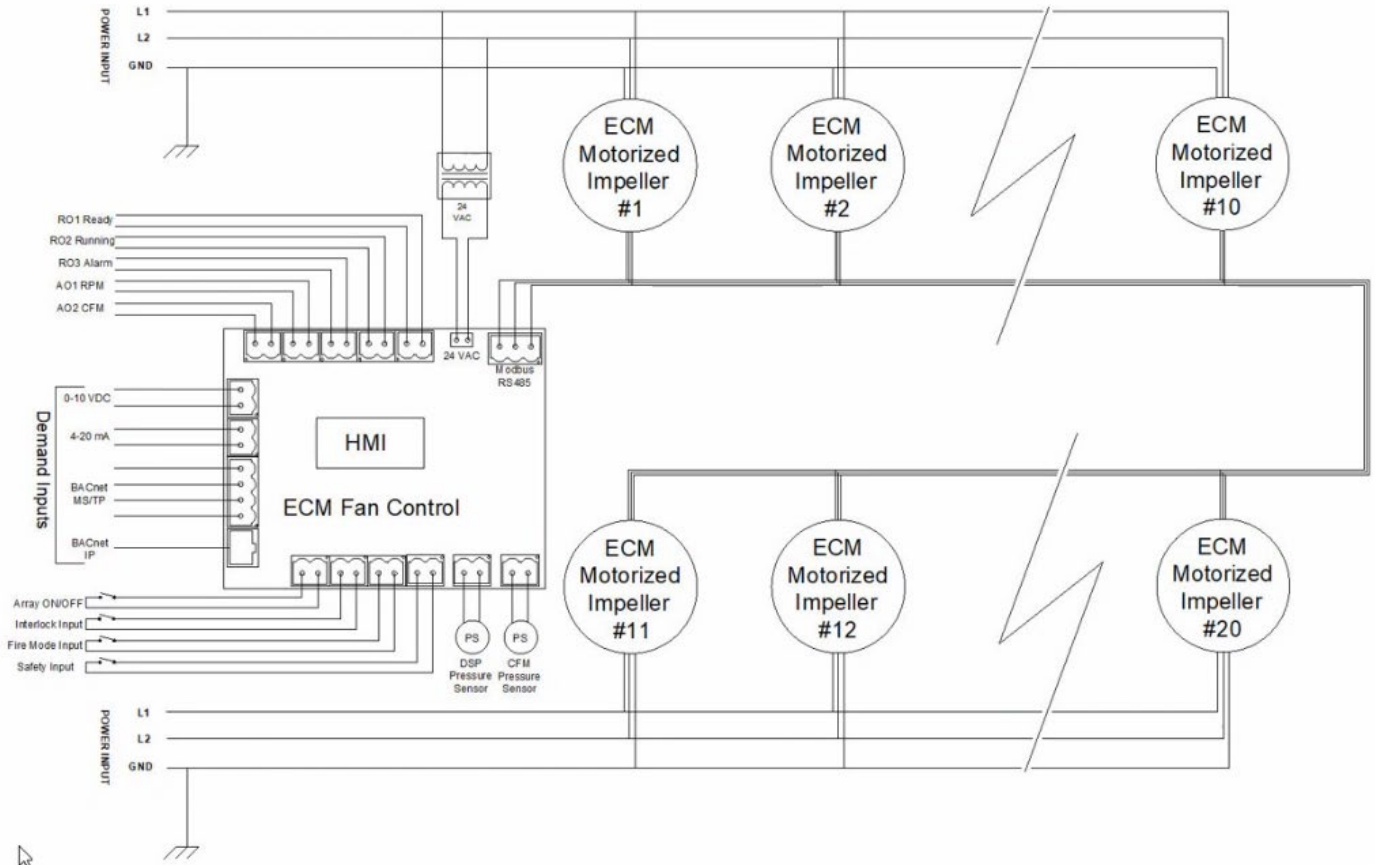

Figure 8: System Block Diagram

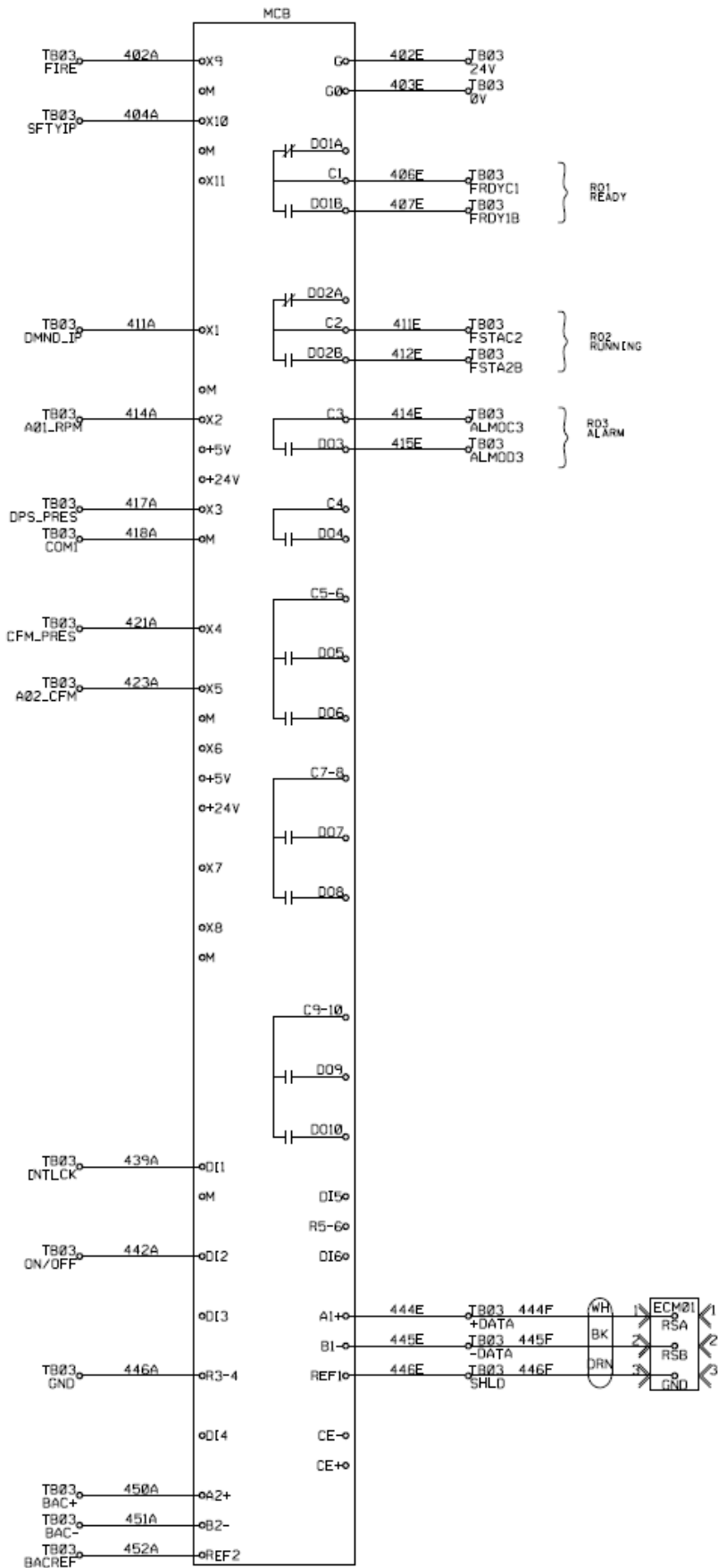

Figure 9: Control Schematic

Fan Array Sensors

The MicroTech 4 fan controller can be wired to the following sensors:

- Duct Pressure Sensor
 - Field provided and installed
- Array CFM Pressure Transducer
 - Factory Installed, Daikin PNs: 2061282 -04 through -07
 - (1) transducer per array

Duct Pressure Sensor

The Duct Pressure Sensor is used by the MicroTech 4 fan controller to calculate duct static pressure downstream of the fan. The Pressure Range Limit will be selected in the controller through the *Main Menu\Commission Unit\Configure Unit\PressureSensSetup* menu. The sensor measurement range can be entered into the controller in the Pressure Sensor Setup menu (up to 10" w.c.), and the pressure sensor output signal can be either in VDC or mA – the output range of the sensor can also be entered into the controller in the same menu.

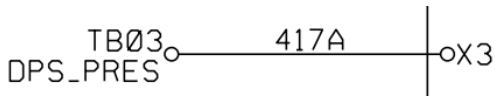

Main Menu \ Commission Unit \ Config Unit \ PressureSensSetup

Menu Display Name	Default	Range	Description
PressSnsrType	None	None mA VDC	PressSenIn is an adjustable item that selects the input signal type to the controller from the Duct Static Pressure sensor.
V/A@MinPress	0	0-20	V/A@MinPress is an adjustable item that informs the controller what the VDC or mA signal magnitude is at the sensor's minimum pressure threshold.
MinPress	0	0-10	MinPress is an adjustable item that informs the controller what the sensor's minimum pressure threshold is.
V/A@MaxPress	10	0-20	V/A@MaxPress is an adjustable item that informs the controller what the VDC or mA signal magnitude is at the sensor's maximum pressure threshold.
MaxPress	8	0-10	MaxPress is an adjustable item that informs the controller what the sensor's maximum pressure threshold is.

Ready Relay

The controller has a Ready Relay contact that provides a digital output that will close when the fan array is ready to run.

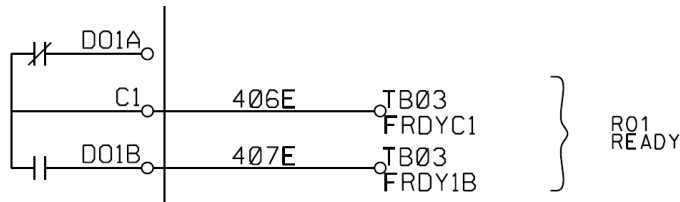

Running Relay

The controller has a Running Relay contact that provides a digital output that will close when the fan array receives a request to run from the specified demand input.

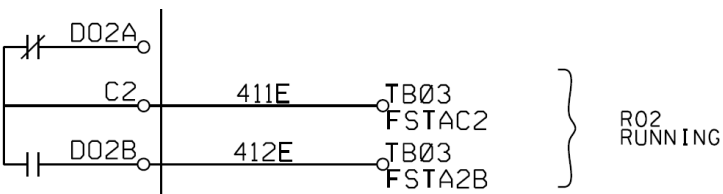

Alarm Output

The controller has an Alarm Output contact that provides a digital output anytime an alarm is active on the controller. The alarm output will close whenever there are any alarms on the MicroTech 4 fan controller.

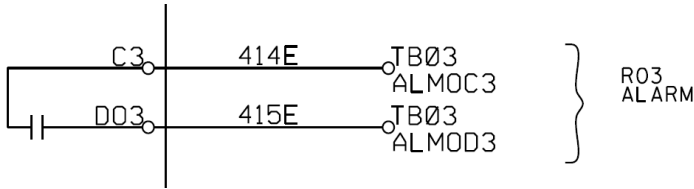

COMMISSIONING AND OPERATIONS

Unit Set-Up

General array set-up configurations are used to adjust the controller's units of measure and the array name.

Unit Set-Up Menu:

Main Menu \ Commission Unit \ Unit Set-Up

Menu Display Name	Default	Range	Description
Unit of Measure	US	US SI CA	Unit of Measure is an adjustable item to indicate if the unit is to display US, Metric, or Canadian units of measure.
Unit Name	-	-	Unit Name is an adjustable item that allows each controller to be given a unique name. This may be useful when multiple units are connected to a single remote HMI. The limit for this value is ten alphanumeric characters.

Units

The units of measure can be set to US, Metric, or Canadian units. For all units of measure, the units will be as follows:

Unit of Measure	English Units	Metric Units	Canadian Units
Weight	lb	kg	kg
Temperature	°F	°C	°C
CFM	ft ³ /min	m ³ /hr	l/s
Pressure	inWc	Pa	Pa
Electrical Power	kW	kW	kW

Date/Time Settings

Controller Date and Time

The controller uses the date and time to timestamp events. The current time and date will not be lost if the unit is turned off for up to forty-eight hours. The time and date can be set from the keypad. The time of day can be set by entering the hour (00-23), minute (00-59), and second (00-59) into the appropriate menu item. The current date can be set by entering the day (01-31), month (01-12) and year (2018-2100) into the appropriate menu item.

Date/Time Menu:

Main Menu \ Commission Unit \ Unit Set-up \ Date/Time Settings

Menu Display Name	Default	Range	Description
Date	-	-	Date is an adjustable item that details the current date
Time	-	0-23	Time is an adjustable item that details the time
UTC Diff	-1:00	-12:45 – 12:45	UTC-difference is an adjustable parameter that can be set to indicate how the local time where the unit is situated differs from the Coordinated Universal Time (adjustable in 15 minute increments).
DLSStartMonth	Mar	NA Jan-Dec	DLS Start Month is an adjustable item that sets the month for daylight savings time to begin.
DLSStartWeek	2ndWeek	1stWeek 2ndWeek 3rdWeek 4thWeek 5thWeek	DLS Strt Week is an adjustable item that sets the week of the month for daylight savings time to begin.
DLEndMonth	Nov	NA Jan-Dec	DLS End Month is an adjustable item that sets the month for daylight savings time to end.
DLEndWeek	1stWeek	1stWeek 2ndWeek 3rdWeek 4thWeek 5thWeek	DLS End Week is an adjustable item that sets the week of the month for daylight savings time to end.
DLEnable	Auto	Off Auto	DLS Enable is an adjustable item that sets whether daylight savings time is enabled.

ENABLE THE UNIT

Configure Unit Menu

The Configure Unit Menu is a commissioning menu that provides adjustable parameters to set the fan operating controls.

Control Mode

Daikin EC fan arrays will be controlled using a factory EC motor for each fan. Each motor is controlled via a Modbus interface when selected with the premium control package.

The fan array will control between an adjustable minimum and maximum fan capacity. The range is adjustable from 0-100%. The setpoints can be adjusted at the unit controller interface or via a network input signal.

- **RPM Control (RPM):** An RPM control type controls the fan array capacity to a fixed speed value.
- **Duct Pressure Control (DSP):** Duct pressure control operates the unit to maintain duct conditions. The fan array is modulated to maintain a duct static pressure setpoint, based on an external pressure sensor (field supplied and installed).
- **CFM Control:** The unit is equipped with a fan airflow measuring system. When the unit is configured to CFM control, the fan array capacity is modulated to maintain an adjustable airflow (CFM) setpoint.
- **Fan Tracking Control (Tracking):** When the unit is set to *Tracking*, the fan array is determined to be the Secondary Fan Array and its capacity is varied to maintain an adjustable offset between the Primary Fan Array capacity and the Secondary Fan Array capacity. The user specifies the offset at maximum primary fan array capacity and the offset at minimum primary fan array capacity, and the secondary fan array controls linearly between the two points. In this configuration the fan array that is set to *Tracking* will only operate off a 0-10V demand signal.

Digital Inputs

The MicroTech 4 fan controller has several digital inputs – a Start Signal Input, an Interlock Input, a Fire Input, and an Alarm Enable Input. Inputs can be landed on terminal block TB03 inside the low voltage control box as shown in the master wiring diagram shown in the Field Control Wiring section of this OM.

Main Menu \ Commission Unit \ Config Unit

Menu Display Name	Default	Range	Description
CtrlMode	RPM	DSP RPM CFM Tracking	CtrlMode is an adjustable item used to select how the fan array is to be controlled. The fan array can normally be controlled by a duct pressure (DSP), constant CFM setpoint (CFM), or RPM which allows the fans to either be set at constant speed or adjusted with a building automation system. The fan array can also be controlled with fan tracking (Tracking), which allows the speed of a Secondary fan array to be controlled based on the output of a Primary fan array.
DmdSrc	0-10 VDC	4-20 mA 0-10 VDC BACnet HMI	DmdSrc is an adjustable item that defines the demand input source. This will be fixed to 0-10 VDC if CtrlMode is set to Tracking.
FireEn	No	Yes No	FireEn is an adjustable item that allows the controller to ignore the Fire Mode Input when set to "No". When enabled, if a contact connected to this input is opened, all alarm contacts are closed and alarm signals are sent out through BACnet and the controller HMI.
IntLckEn	No	Yes No	IntLckEn is an adjustable item that allows the controller to ignore the Interlock Input when set to "No". When enabled, this input delays fan operation until an external contact is closed.
AlmInEn	No	Yes No	AlmInEn is an adjustable item that allows the controller to ignore the Safety Input when set to "No". When enabled, if a contact connected to this input is opened, the fan will not operate under any circumstances.
StrtSgnlEn	No	Yes No	StrtSgnlEn is an adjustable item allows the controller to ignore the Array ON/OFF Input when set to "No". When enabled, this input allows the fan array operation to be controlled on/off with an external contact closure.

Fan Tracking Menu

The Fan Tracking Menu is a commissioning menu that provides adjustable parameters to set the fan operating controls – this menu is only visible when the control mode is set to Tracking (**Main Menu \ Commission Unit \ Config Unit \ CtrlMode**).

Main Menu \ Commission Unit \ Configure Unit \ Fan Tracking \ Set Tracking Min

Menu Display Name	Default	Range	Description
SetTckMin	No	Yes No	SetTckMin is an adjustable item allows the user to change the Maximum Tracking RPM value when set to Yes
MinRPMTck	0	0-3300	MinRPMTck is an adjustable item that controls the speed of the secondary fan array to balance the secondary fan array when the primary fan array is at its maximum set point.
SaveTckData	No	Yes No	SaveTckData is a menu item that must be set to Yes after any adjustable items in this menu are changed to save those changes.

Main Menu \ Commission Unit \ Configure Unit \ Fan Tracking \ Set Tracking Max

Menu Display Name	Default	Range	Description
SetTckMax	No	Yes No	SetTckMax is an adjustable item allows the user to change the Maximum Tracking RPM value when set to Yes.
MaxRPMTck	2600	0-3300	MaxRPMTck is an adjustable item that controls the speed of the secondary fan array to balance the secondary fan array when the primary fan array is at its maximum set point.
SaveTckData	No	Yes No	SaveTckData is a menu item that must be set to Yes after any adjustable items in this menu are changed to save those changes.

Primary Fan - Secondary Fan Tracking

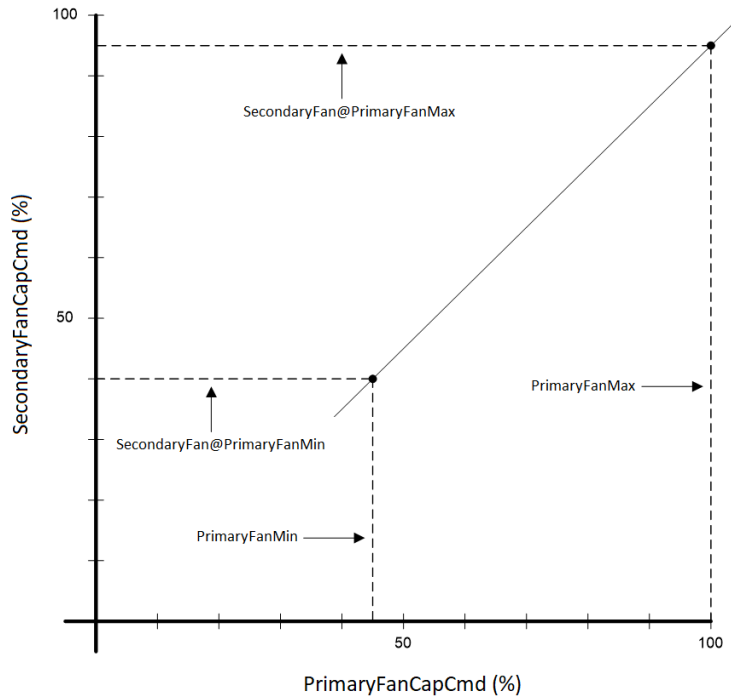

The field process for setting these parameters will be as follows:

1. The Primary fan array shall be set to maximum air flow conditions and allowed to stabilize.
2. The Secondary fan array shall be balanced while the Primary fan is at maximum airflow conditions as follows:
 - a. On the Secondary fan array, set the *SetTckMax* parameter to Yes.
 - b. The *MaxRPMTck* value will then be adjusted until the desired balance is obtained.
 - c. The parameters shall be saved by selecting *SaveTckData*.
3. The Primary fan array shall be set to minimum air flow conditions and allowed to stabilize.
4. The Secondary fan array shall be balanced while the Primary fan is at minimum airflow conditions as follows:
 - a. On the Secondary fan array, set the *SetTckMin* parameter to Yes.
 - b. The *MinRPMTck* value will then be adjusted until the desired balance is obtained.
 - c. The parameters shall be saved by selecting *SaveTckData*.

Note: Ideally the minimum and maximum conditions should be checked with the outdoor dampers (if present in the unit) at minimum and maximum positions to assure there are not significantly different requirements depending on the outdoor damper position. If the differences are significant then the parameters may be manually adjusted to compromise between the two conditions. If the differences are too great it may be necessary to change to a different control method for the application.

Note: Setting the minimum and maximum tracking points will not necessarily establish minimum and maximum Primary fan array air flow modulation ranges but rather simply establishes the slope of the tracking curve. The curve line will be projected up to effective max Primary fan array air flow capacity and down to the effective minimum Primary fan array air flow capacity.

CFM Sensor Setup

The CFM Sensor Setup Menu allows the user to set the parameters for the specific sensor installed in the array. The Array CFM Pressure Transducer is used by the MicroTech 4 fan controller to calculate the total CFM delivered by the array. The Pressure Range Limit will be selected in the controller through the *Main Menu\Commission Unit\Configure Unit\CFMSensSetup* menu. The sensor measurement range can be entered into the controller in the CFM Sensor Setup menu (up to 40" w.c.), and the pressure sensor output signal can be either in VDC or mA – the output range of the sensor can also be entered into the controller in the same menu.

Main Menu \ Commission Unit \ Config Unit \ CFMSenSetup

Menu Display Name	Default	Range	Description
CFMSnrType	mA	None mA VDC	CFMSnrType is an adjustable item that selects the input signal type to the controller from the CFM sensor.
V/A@MinPressCFM	4	0-20	V/A@MinPressCFM is an adjustable item that informs the controller what the VDC or mA signal magnitude is at the sensor's minimum pressure threshold.
MinPressCFM	0	0-40	MinPressCFM is an adjustable item that informs the controller what the sensor's minimum pressure threshold is.
V/A@MaxPressCFM	20	0-20	V/A@MaxPressCFM is an adjustable item that informs the controller what the VDC or mA signal magnitude is at the sensor's maximum pressure threshold.
MaxPressCFM	5	0-40	MaxPressCFM is an adjustable item that informs the controller what the sensor's maximum pressure threshold is.

Daikin PN	Pressure Range Limit
206128207	0-5" W.C.
206128204	0-10" W.C.
206128205	0-20" W.C.
206128206	0-40" W.C.

Table 2: Pressure Range Limits for Daikin Pressure Transducers

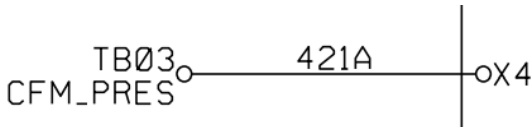

CONFIGURE FANS MENU

The Configure Fans Menu allows the user to configure the fan-specific settings for the array.

Main Menu \ Commission Unit \ Config Fans

Menu Display Name	Default	Range	Description
FanNumber	4	1-20	FanNumber is an adjustable item that informs the controller of the number of fans in the array.
Fan Supplier	Delta	EBM Delta	Fan Supplier is an adjustable item that informs the controller of the brand of fans installed in the array.
DeltaSize	355	355 450 560	DeltaSize is an adjustable item that informs the controller of the nominal diameter of the fan impellers installed in the array. Units are in mm.
EBMSize	355	355 450 560 630	EBMSize is an adjustable item that informs the controller of the nominal diameter of the fan impellers installed in the array. Units are in mm.
FanVoltage	460	208/230 460	FanVoltage is an adjustable item that informs the controller of the voltage of the fans installed in the fan array. Units are in VDC
Power_460V	1.9	1.7 1.9 2.7 2.9 3.0 3.3 4.4 4.58 4.95 5.2 5.9 6	Power_460V is an adjustable item that informs the controller of the nameplate 460V power rating of the fans installed in the fan array. Units are in kW.

		7.1 9.8	
Power_230V	1.9	1.3 1.4 1.7 1.9 2.7 3.0 3.1 3.3 3.8 4.58 4.95 5.5 5.9 6.3 6.3	Power_230V is an adjustable item that informs the controller of the nameplate 208/230V power rating of the fans installed in the fan array. Units are in kW.
DecTime	10	0-60	DecTime is an adjustable item that controls the time it will take to change the fan speed from maximum RPM to minimum RPM.
IncTime	10	0-60	IncTime is an adjustable item that controls the time it will take to change the fan speed from minimum RPM to maximum RPM.
MaxRPM	2600	0-3300	MaxRPM is an adjustable item that sets the maximum fan speed for the application.
MinRPM	0	0-3300	MinRPM is an adjustable item that sets the minimum fan speed for the application.
Vent Limit	0	0-3300	Vent Limit is an adjustable item that sets the fan speed when the vent limit is activated.
RPMDiff	300	0-3300	RPMDiff is an adjustable item that sets the maximum differential between the RPM setpoint and the actual RPM of the fans in the array. If this differential is exceeded, an alarm will be displayed.
AdptvSpd	Off	On Off	AdptvSpd is an adjustable item that enables or disables adaptive speed. If enabled, when a fan in the array is lost or disabled, the remaining fans will increase their RPM to compensate.

QUICK MENU

Items in the Quick Menu contain basic unit operating status and control set point parameters. The items shown in the Quick Menu are Read Only if a valid password has not been entered. The following are brief descriptions of the Quick Menu items. No password is required to view the Quick Menu.

Main Menu \ Quick Menu

Menu Display Name	Default	Range	Description
HMICmd	--	0-100%	HMICmd is an adjustable item that sets the HMI demand setpoint.
Unit Mode	--	Off Normal Manual Emergency	Unit Mode is a read only item that displays the status of operation in which the unit is currently operating. The unit mode can be any of the status values shown.
Unit Alm	No Alarm	No Alarm Fan #1 Alarm Fan #2 Alarm ... Fan #19 Alarm Fan #20 Alarm Sensor Error Fire Alarm External Safety Alarm Interlock Alarm Pressure Alarm	Unit Alm is a read only item which displays if, and what, alarm is active.
General Alm	Off	Off On	General Alm is a read only item that indicates the state of the Alarm Output relay contacts (AO3)

Array ON/OFF	Off	Off On	Array ON/OFF is a read only item that displays the current state of the array on/off digital input
AvgFanSpd	--	0-3300	AvgFanSpd is a read only item that displays the average speed of all fans in the array in RPM
FanSpd Cmd	0	0-100%	FanSpd Cmd is a read only item that displays the fan array speed demand setpoint
Array Power	--	--	Array Power is a read only item that displays the total power usage of the array in kilowatts
DmdSp	0	0-100%	DmdSp is an adjustable item that sets the demand setpoint for either CFM or DSP control mode
DSP Pressure	0	0.0-40.0	DSP Pressure is a read only item that displays the pressure reading when control mode is set to DSP
DSP SP	0	0.0-40.0	DSP SP is an adjustable item that sets the duct static pressure setpoint when control mode is DSP
DP Alm SP	0	0.0-40.0	DP Alm SP is an adjustable item that sets the static pressure setpoint that triggers an alarm
CFM Pressure	--	0.0-40.0	CFM Pressure is a read only item that displays the CFM pressure
Air Fl	--	--	Air Fl is a read only item that displays the total airflow of the fan array in CFM
CFM SP	0	0-200,000	CFM SP is an adjustable item that sets the CFM setpoint when control mode is CFM
Demand Input	0	0-100%	Demand Input is a read only item that displays the fan array speed command input

UNIT STATUS

The “Unit Status” menu provides a summary of basic unit status and control items. This menu summarizes the current operating state of the unit, giving the operating state the unit is in, along with the current capacity level of that operating state.

Main Menu \ Quick Menu \ Unit Status

Menu Display Name	Default	Range	Description
Unit Mode	--	Off Normal Manual Emergency	Unit Mode is a read only item that displays the status of operation in which the unit is currently operating. The unit mode can be any of the status values shown.
Unit State	--	Off Ready Running Manual Alarm Emergency	Unit State is a read only item that displays the current state of the unit. The unit state can be any of the values shown
Array ON/OFF	Off = 0	Off = 0 On = 1	Array ON/OFF is a read only item that displays the current state of the array on/off digital input
RO1 Ready	Off	Off On	RO1 Ready is a read only item displays the state of the Fan Ready relay
RO2 Running	Off	Off On	RO2 Running is a read only item that displays the state of the Fan Running relay
RO3 Alarm	Off	Off On	RO3 Alarm is a read only item that displays the state of the Fan Alarm relay
AirFl	--	--	Air Fl is a read only item that displays the total airflow of the fan array in CFM

VIEW STATUS

The “View Status” menu provides a series of read-only menus to observe the status of individual fans, IO status, and the current date and time settings.

FAN STATUS

The Fan Status Menu displays the fan operation and the relevant current control parameters.

Main Menu \ View Status \ Fan Status

Menu Display Name	Default	Range	Description
Fan Run Cmd	Off	On Off	Fan Run Cmd is a read only item that displays the fan array run command output
Fan Spd Cmd	--	0-100%	FanSpd Cmd is a read only item that displays the fan array speed command output
Avg Fan Spd	--	0-3300	AvgFanSpd is a read only item that displays the average speed of all fans in the array in RPM
CFM Pressure	--	0.0-40.0	CFM Pressure is a read only item that displays the CFM pressure
AirFl	--	0-200,000	Air Fl is a read only item that displays the total airflow of the fan array in CFM
IntLck	Off	Off On	Intlck is a read only item that displays the interlock switch status
IntLckTm	180s	0-180 seconds	IntLckTm is the timer delay between the interlock relay being activated and the interlock digital input being received before the interlock alarm timer is activated
IntLckAlm	Off = 0	Off = 0 On = 1	IntLckAlm indicates if the array is in interlock alarm status because the interlock timer ran down to 0 seconds

Fan Menus

The Fan Menus display each individual fan operation status.

Main Menu \ View Status \ Fan Status \ Fan# (1-20)

Menu Display Name	Default	Range	Description
SN	--	--	SN is a read only item that displays the fan motor serial number.
Type	--	--	Type is a read only item that displays the motor model number.
Hour	--	--	Hour is a read only item that displays the runtime of the fan in hours.
MdIT	--	--	MdIT is a read only item that displays the winding temperature within the motor.
MtrT	--	--	MtrT is a read only item that displays the motor temperature.
ElcT	--	--	ElcT is a read only item that displays the temperature of the internal electronics.
SpdFb	--	0-3300	SpdFb is a read only item that displays the RPM feedback from the motor.
MaxRPM	--	0-3300	MaxRPM is a read only item that displays the maximum RPM of the motor.
Direction	CW	CW CCW	Direction is a read only item that displays the rotational direction setting of the fan wheel.
DCLink_VRef	--	--	DCLink_VRef is a read only item that displays the DC Link reference voltage.
Voltage	--	--	Voltage is a read only item that displays the motor voltage.
DCLink_CRef	--	--	DCLinkCRef is a read only item that displays the DC Link reference current.
Current	--	--	Current is a read only item that displays the motor current.
Modlvl	--	0-100%	Modlvl is a read only item that displays the
Pwr	--	--	Pwr is a read only item that displays the motor power.
RPMAlm	--	OK Flt	RPMAlm is a read only item that displays whether there is a RPM alarm present.
ComErr	--	OK Flt	ComErr is a read only item that displays whether there is a communication error present.
AlmCode	Online	--	AlmCode is a read only item that displays the alarm code active (if any), otherwise will display "Online".

Alarm Status

The Alarm Status Menu displays alarm information for individual fans. Damage could occur if any alarms are ignored.

Main Menu \ View Status \ Fan Status \ Fan# (1-20) \ Alarm Status

Menu Display Name	Default	Range	Description
PHA	Inactive = 0	Active = 1 Inactive = 0	PHA is the phase failure (3-phase devices) or line undervoltage (single-phase devices) alarm for EBM fans
TFE	Inactive = 0	Active = 1 Inactive = 0	TFE is the output stage overheating alarm for EBM fans
SKF	Inactive = 0	Active = 1 Inactive = 0	SKF is the communication error between master controller and slave controller alarm for EBM fans
FB	Inactive = 0	Active = 1 Inactive = 0	FB is the fan bad alarm, which is a general error for EBM fans
TFM	Inactive = 0	Active = 1 Inactive = 0	TFM is is the motor overheating alarm for EBM fans
HLL	Inactive = 0	Active = 1 Inactive = 0	HLL is the hall sensor error alarm for EBM fans
BLK	Inactive = 0	Active = 1 Inactive = 0	BLK is the motor blocked alarm for EBM fans
n_Limit	Inactive = 0	Active = 1 Inactive = 0	n_Limit is the speed limit exceeded alarm for EBM fans
RL_Cal	Inactive = 0	Active = 1 Inactive = 0	RL_Cal is the rotor position sensor calibration error alarm for EBM fans
UzLow	Inactive = 0	Active = 1 Inactive = 0	UzLow is the DC-link undervoltage alarm for EBM fans
OC	Inactive = 0	Active = 1 Inactive = 0	OC is the DCbus average over protection current alarm for Delta fans
OV	Inactive = 0	Active = 1 Inactive = 0	OV is the DCbus average over protection voltage alarm for Delta fans
UV	Inactive = 0	Active = 1 Inactive = 0	UV is the DCbus average under protection voltage alarm for Delta fans
OT	Inactive = 0	Active = 1 Inactive = 0	OT is the EE over protection temperature alarm for Delta fans
Lock	Inactive = 0	Active = 1 Inactive = 0	Lock is the fan lock alarm for Delta fans
PL	Inactive = 0	Active = 1 Inactive = 0	PL is the 3~ AC lose phase alarm for Delta fans
RRW	Inactive = 0	Active = 1 Inactive = 0	RRW is the fan reverse run alarm for Delta fans
Hall	Inactive = 0	Active = 1 Inactive = 0	Hall is the hall signal abnormal alarm for Delta fans
EEPROM	Inactive = 0	Active = 1 Inactive = 0	EEPROM is the EEPROM read/write fail alarm for Delta fans
POC	Inactive = 0	Active = 1 Inactive = 0	POC is the DCbus peak over current alarm for Delta fans
AC_OV	Inactive = 0	Active = 1 Inactive = 0	AC_OV is the AC bus over protection voltage alarm for Delta fans
AC_UV	Inactive = 0	Active = 1 Inactive = 0	AC_UV is the AC bus under protection voltage alarm for Delta fans

Warn Status

The Warn Status Menu displays warning information for individual EBM fans. Damage could occur if any warnings are ignored.

Main Menu \ View Status \ Fan Status \ Fan# (1-20) \ Warn Status

Menu Display Name	Default	Range	Description
I_Limit	Inactive = 0	Active = 1 Inactive = 0	I_Limit is the current limitation is engaged

L_High	Inactive = 0 Active = 1 Inactive = 0	L_High is the line impedance too high (DC-link voltage unstable)
P_Limit	Inactive = 0 Active = 1 Inactive = 0	P_Limit is the power limiter is currently engaged
TE_high	Inactive = 0 Active = 1 Inactive = 0	TE_high is the output stage temperature is high
TM_High	Inactive = 0 Active = 1 Inactive = 0	TM_High is the motor temperature is high
TEI_high	Inactive = 0 Active = 1 Inactive = 0	TEI_high is the temperature inside electronics is high
UzLow	Inactive = 0 Active = 1 Inactive = 0	UzLow is the DC-link voltage is low
LRF	Inactive = 0 Active = 1 Inactive = 0	LRF is shedding function is active
Brake	Inactive = 0 Active = 1 Inactive = 0	Brake is triggered in instances where an external force causes the fan/motor to run in the wrong direction at high speed for a prolonged period of time, so the motor is unable to start properly
UzHigh	Inactive = 0 Active = 1 Inactive = 0	UzHigh is the DC-link voltage is high
UeHigh	Inactive = 0 Active = 1 Inactive = 0	UeHigh is the line voltage is high
RL_Cal	Inactive = 0 Active = 1 Inactive = 0	RL_Cal is the calibration of the rotor position sensor is in progress
Op_circ	Inactive = 0 Active = 1 Inactive = 0	Op_cir is triggered when the analog input voltage is less than the open circuit limit value
n_Low	Inactive = 0 Active = 1 Inactive = 0	n_Low is the actual speed is less than the speed limit set for speed monitoring

IO STATUS

The IO Status Menu displays the status of all the I/O variables.

Main Menu \ View Status \ IO Status

Menu Display Name	Default	Range	Description
Array ON/OFF	Off = 0	Off = 0 On = 1	Array ON/OFF is a read only item that displays the current state of the array on/off digital input
Demand Input	0	0-100%	Demand Input is a read only item that displays the fan array speed command input
DSP Press Snsr	0	--	DSP Press Snsr is a read only item that displays the DSP pressure sensor reading
CFM Press Snsr	0	--	CFM Press Snsr is a read only item that displays the CFM pressure sensor reading
Interlock Input	Off = 0	Off = 0 On = 1	Interlock Input is a read only item that displays the interlock switch status
Safety Input	Off = 0	Off = 0 On = 1	Safety Input is a read only item that displays the external safety alarm input status
Fire Mode Input	Off = 0	Off = 0 On = 1	Fire Mode Input is a read only item that displays the fire alarm input status
RO1 Ready	Off = 0	Off = 0 On = 1	RO1 Ready is a read only item displays the state of the Fan Ready relay
RO2 Running	Off = 0	Off = 0 On = 1	RO2 Running is a read only item that displays the state of the Fan Running relay
RO3 Alarm	Off = 0	Off = 0 On = 1	RO3 Alarm is a read only item that displays the state of the Fan Alarm relay
AO1 RPM	0%	0-100%	AO1 RPM is a read only item that reports the RPM value being sent from the controller to the fans in the array.
AO2 CFM	0%	0-100%	AO2 CFM is a read only item that reports the CFM value being sent from the controller to the fans in the array.

OTHER CONFIGURATIONS

Damper Control

When the unit is equipped with a set of dampers, the damper can be set up with an end switch that is connected to the MicroTech 4 fan controller Interlock Input. This can be used to signal the controller that the damper is in the proper position for fan startup. The RO2 Running can also be used to send a command signal to the damper actuator(s) to adjust the damper(s) between two positions. Reference the Field Control Wiring section of this OM for specific control locations on TB03.

Manual Array Operation

Manual Control can be initiated during start up to control individual features of the fan array independent of the control sequence. Place the unit into Manual Control mode through the controller keypad menu *Main Menu \ Manual Control \ Manual Mode = Manual*. Once in manual control, you can activate fans manually.

Note: Manual Operation is not intended for extended operation beyond troubleshooting or initial start-up. After 60 minutes, the controller will automatically revert to normal operation.

Main Menu \ Manual Control

Menu Display Name	Default	Range	Description
Manual Mode	Normal	Normal ManCtrl	Manual Ctrl is an adjustable item that allows the unit to enter manual control mode.
Count Down	0	0-60	Count Down is a ready only item that reports how many minutes are left before the controller reverts back to normal operation.
Manual Speed	0%	0-100%	Manual Speed is an adjustable item that manually drives the supply fan to a capacity.
AvgFanSpd	0 RPM	0-4000 RPM	AvgFanSpd is a read only item that reports the average speed of all fans in the array
RO1 Ready	On	Off On	RO1 Ready is an adjustable item that sets the output to the Ready Relay to the specified value (A value of On here will close the contact).
RO2 Running	On	Off On	RO2 Running is an adjustable item that sets the output to the Running Relay to the specified value (A value of On here will close the contact).
RO3 Alarm	Off	Off On	RO3 Alarm is an adjustable item that sets the output to the Alarm Relay to the specified value (A value of On here will close the contact).
AO1 RPM	0%	0-100%	AO1 RPM is a read only item that reports the RPM value being sent from the controller to the fans in the array.
AO2 CFM	0%	0-100%	AO2 CFM is a read only item that reports the CFM value being sent from the controller to the fans in the array.
Alarm Reset	Off	Off On	Alarm Reset is an adjustable item will reset all alarms on the controller when set to On.

BMS COMMUNICATIONS

Reference ED Protocol Document – ED 19122 Vision ECM Fan Controller for additional detail on BMS Communications.

BACnet IP Set-Up

Main Menu \ BMS Communications \ BACnet IP

Menu Display Name	Default	Range	Description
Name	MT4_DFA_#### '####' is the instance ID	-	Up to a 17 Character Device Object Name. Change this value as needed to match installation parameters
Dev Instance	####, default is the last 4 digits of the serial number	0-4194302	Device Instance of the BACnet communication module
UDP Port	47808	0-65535	UDP Port is the User Datagram Protocol. The UDP Port allows host to host communication via the IP network and is used to identify the application process in the destination unit. Only change the UDP Port if there are multiple subnets. See a network administrator before modification.
DHCP	On	On Off	DHCP is the Dynamic Host Configuration Protocol. The DHCP is a network protocol that enables a server to automatically assign an IP Address. Set to Off if a static IP address is needed.

IP	127.0.0.1	-	IP is the IP Address of the BACnet Communication module.
Mask	255.255.255.0	-	Mask is the Subnet Base of the BACnet Communication Module.
Gwy	127.0.0.1	-	Gwy is the gateway address.
Enable	Passive		
Save Config	No	No Yes	Save Config saves the configuration changes made in the menu items above

BACnet MSTP Set-Up

Main Menu \ BMS Communications \ BACnet MS/TP

Menu Display Name	Default	Range	Description
Name	MT4_DFA_### # '####' is the instance ID	-	Up to a 17 Character Device Object Name. Change this value as needed to match installation parameters
Dev Instance	####, default is the last 4 digits of the serial number	0-4194302	Device Instance of the BACnet communication module
MSTP Address	18	0-127	This is the MST/TP address of the BACnet communication module.
Baud Rate	76800	9600 19200 38400 76800	Baud Rate is an adjustable item that is the Data Transfer speed.
Max Master	127	1-127	Max Master is an adjustable item that specifies the highest possible address for master nodes and shall be less than or equal to 127.
Max Info Frm	1	1-32	Max Info Frm is an adjustable item that specifies the maximum number of information frames the BACnet communication module may send before it must pass the token.
BACnetOverRS485	Passive		
Save Config	No	No Yes	Save Config saves the configuration changes made in the menu items above

SERVICE MENUS

The Service Menus section covers several menus that will be useful while maintaining the equipment.

Fan Service

Main Menu \ Service Menus \ Fan Service

Menu Display Name	Default	Range	Description
Fan Array Op Hour	-	--	Fan Array Op Hour indicates the number of run hours on the array
Fan Array Cycle Cnt	-	--	Fan Array Cycle Cnt indicates the number of operational cycles on the array (number of times the array has been started/stopped)

Operating Hours Menu

Main Menu \ Service Menus \ Fan Service \ Operating Hours

Menu Display Name	Default	Range	Description
Fan1	-	0-999,999h	Fan Hours is a status only item that displays the number run hours on the Fan

Fan2	-	0-999,999h	Fan Hours is a status only item that displays the number run hours on the Fan
...	-	0-999,999h	Fan Hours is a status only item that displays the number run hours on the Fan
FanXX (max 20 fans)	-	0-999,999h	Fan Hours is a status only item that displays the number run hours on the Fan

Modbus

The Modbus menu is to be used for addressing the fans in the field.

Main Menu \ Service Menus \ Modbus

Menu Display Name	Default	Range	Description
Fan1CommStat	-	Fault OK	Fan1CommStat is a status only item that displays the current communication status for fan 1
Fan2CommStat	-	Fault OK	Fan2CommStat is a status only item that displays the current communication status for fan 2
....			
FanXX (max 20 fans)	-	Fault OK	FanXXCommStat is a status only item that displays the current communication status for fan XX
ModbusResistor	-	0x0000	ModbusResistor indicates the bus pull up/pull down resistor, termination resistor configuration
DefaultECMStat	-	No Yes N/A	DefaultECMStat indicates if there is a fan with a default factory address available
ChngECMTo	Default	Default 1-20	ChngECMTo is an adjustable item that sets which master fan address will be changed to during the field addressing process
ChngECMFrom	Default	Default 1-20	ChngECMFrom is an adjustable item that sets which master fan address will be changed from during the field addressing process
Save Config	No	No Yes	Save Config saves the configuration changes made in the menu items above

To address the fans in the field, follow the procedure below:

1. Ensure the controller has power (requires a 24V power supply if not powered from the transformer in the fan array power box).
2. Ensure the fan(s) have power - the fans can be powered one at a time, or the whole array can be powered simultaneously. If powered individually, the fans need a minimum of 15W @ 110V single phase power in order to to be addressed.
3. Confirm that the array is configured for the correct number of fans in the fan service menu (Main Menu \ Commission Unit \ Config Fans)
4. Disconnect the modbus communication harnesses from all of the fans in the array except for one (ideally the fan closest to the control panel), leaving that fan connected to the MT4 controller.
5. Navigate back to the Modbus menu (*Main Menu \ Service Menus \ Modbus*), and check to see if the fan is ready to be addressed – the DefaultECMStat should show “Yes” and all FanCommStat variables should say “Flt”
6. Reference the fan arrangement label (example shown below) to determine the fan number being addressed.

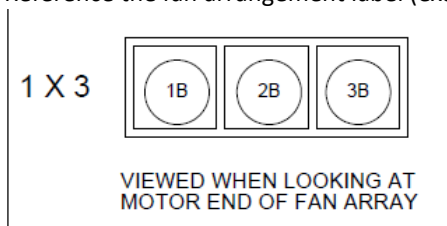

7. Set ChgnECMTo to be the number of the fan to be addressed, and set ChngECMFrom to “Default”.
8. Set Save Config to “Yes”. After a short delay, the FanCommStat entry corresponding to the fan being addressed should change from Flt to OK.
9. Cycle power to the fan that was just addressed (or the entire array).
10. The next fan to be addressed can be connected back into the Modbus control “daisy chain”.
11. Repeat steps 5-9 until all fans have been addressed.

Air Flow

The Air Flow menu is used to define the constants utilized when the fan array control mode is constant CFM. These values are used with the pressure sensor on the leading fan to calculate the airflow. The fan array total airflow is then calculated by multiplying the calculated airflow by the quantity of running fans. “Altitude” is the only field set item in this menu. The other variables are defined by other parameter inputs – e.g. fan size.

Main Menu \ Service Menus \ Air Flow

Menu Display Name	Default	Range	Description
Altitude	0	0-32,808 ft	Altitude should be set to the altitude of the jobsite
C1	--	355mm – 1372.74 450mm – 2226.07 560mm – 3224.71 630mm – 4058.68	C1 is the coefficient factor for free and ducted inlet, using the standard density method. The C1 value depends on the impeller size of the ECM fan
Area	--	355mm – 0.485 450mm – 0.778 560mm – 1.341 630mm – 1.667	Area is the inlet funnel throat area, defined by the fan impeller size
Airfl	--	0-200,000 CFM	Airfl is the airflow of the array
AirFlRel	--	0-100%	AirFlRel is the relative airflow of the array from 0-100%
AF	--	0.70-1.00	AF is the altitude factor, dependent on the defined altitude

DSP Control

Main Menu \ Service Menus \ DSP Control

Menu Display Name	Default	Range	Description
DSP Period	5s	0-999s	DSP Period is an adjustable item that sets the “sample time” used in the PI control function to vary the fan capacity when duct static pressure (DSP) control is selected.
DSP Gain	0.2	0.0-100.0	DSP Gain is an adjustable item that sets the “gain” used in the PI control function to vary the fan capacity when duct static pressure (DSP) control is selected.
DSP PAT	30s	0-999s	DSP PAT is an adjustable item that sets the “project ahead time” used in the PI control function to vary the fan speed when DSP Control is selected .
DSP MaxChg	4%	0-100%	DSP MaxChg is an adjustable item that sets the maximum value of increase or decrease of the fan capacity each period used in the PI control function to vary the fan capacity when duct static pressure (DSP) control is selected .

CFM Control

Main Menu \ Service Menus \ CFM Control

Menu Display Name	Default	Range	Description
Flow DB	3%	0-100%	Flow DB is an adjustable item that sets the “deadband” used in the PI control function to vary the supply fan speed when CFM control is selected.
Flow Period	30s	0-999s	Flow Period is an adjustable item that sets the “sample time” used in the PI control function to vary the supply fan speed when CFM control is selected.
Flow Gain	0.1	0.0-100.0	Flow Gain is an adjustable item that sets the “gain” used in the PI control function to vary the supply fan speed when CFM control is selected.
Flow PAT	60s	0-999s	Flow PAT is an adjustable item that sets the “project ahead time” used in the PI control function to vary the fan speed when CFMControl is selected .
Flow MxChg	5%	0-100%	Flow MxChg is an adjustable item that sets the maximum value of increase or decrease of the supply fan speed each period used in the PI control function to vary the supply fan speed when CFM control is selected.

UNIT MAINTENANCE

Main Menu \ Unit Maintenance

Menu Display Name	Default	Range	Description
Unit Op Hour	-	--	Unit Op Hour indicates the number of run hours on the unit
Unit Cycle Cnt	-	--	Unit Cycle Cnt indicates the number of cycles on the unit

Main Menu \ Unit Maintenance \ Operating Hours

Menu Display Name	Default	Range	Description
Fan 1		0.0-999999.0h	Fan Hours is a status only item that displays the number run hours on the Fan
Fan 2		0.0-999999.0h	Fan Hours is a status only item that displays the number run hours on the Fan
....			
Fan XX (Max 20 fans)		0.0-999999.0h	Fan Hours is a status only item that displays the number run hours on the Fan

ALARMS

Alarms provide the user with information about abnormal conditions that affect unit operation. The cause of the alarm should be investigated and eliminated before the unit or any disabled equipment in it is placed back into service.

Viewing Alarms

The Active Alarms menu displays up to 10 active alarms and is located in the menu at *Main Menu \ Alarm List \ Active Alarms*. Pushing the scroll wheel in, will show details about the alarm as well as when it occurred. The Alarm Log (located in the menu at *Main Menu \ Alarm List \ Alarm Log*), shows the same information, but up to 50 of the latest alarms both active and previous alarms.

All active alarms as well as the date and time that they were detected are displayed on the Active Alarm menu. The last fifty alarm "events" detected as well as the date and times that they were detected are displayed on the Alarm Log menu. An alarm "event" is either an alarm becoming active or being cleared. A "+" symbol precedes the active alarm event and a "-" symbol precedes the cleared alarm event. These alarms are displayed in the order that they were detected. The alarm that was detected most recently is displayed first. Multiple occurrences of the same alarm may appear.

OTHER MENU ITEMS

About This Unit

Main Menu \ About This Unit

Menu Display Name	Default	Range	Description
Unit Name	-	-	Unit Name is an adjustable field that allows the user to name the fan section
SO_Item	-	-	SO_Item displays the unit order number and is programmed from the factory
Unit SN	-	-	Unit SN displays the unit serial number and is programmed from the factory
App Version	-	-	App Version displays the installed version of the controller software code

Main BSP	-	-	Main BSP displays the installed version of the controller operating system
HMI GUID	-	-	HMI GUID displays the installed version of the controller HMI
OBH GUID	-	-	OBH GUID displays the installed version of the controller OBH

MICROTECH 4 INPUTS/OUTPUTS

The complete set of Inputs and Outputs that are possible on a Vision EC Fan Controller are listed below.

Main Control Board

I/O Location	Description	I/O Type	I/O Voltage	Module	Comments
D1	Interlock Input	DI	Dry Contact	MT4	Optional, if it's available, ON- Ready, OFF-Not ready;
D2	Array ON/OFF	DI	Dry Contact	MT4	Optional, if it's available, ON- Start, OFF-Stop;
DU1	Spare	DI	24VAC Active DI	MT4	
DU2	Spare	DI	24VAC Active DI	MT4	
DL1	Spare	DI	110VAC Active DI	MT4	
DL2	Spare	DI	110VAC Active DI	MT4	
X1	Demand Input	AI	0-10V / 4-20mA	MT4	depending on control method, get auto configured based on control method (RPM/Tracking) and control source.
X2	AO1 RPM	AO	0-10V Output	MT4	RPM output, fan speed command sending to the secondary controller
X3	DSP Pressure Sensor	AI	0-10V / 4-20mA	MT4	DSP pressure sensor, sensor signal type as well as sensor scaling shall be done in sensor config menu.
X4	CFM Pressure Sensor	AI	0-10V / 4-20mA	MT4	CFM pressure sensor sensor signal type as well as sensor scaling shall be done in sensor config menu.
X5	AO2 CFM	AO	0-10V Output	MT4	CFM output
X6	Spare	XIO		MT4	
X7	Spare	XIO		MT4	
X8	Spare	XIO		MT4	
X9	Fire Mode Input	XI	Dry Contact	MT4	Optional, if it's available, ON- alarm, OFF-OK;
X10	Safety Input	XI	Dry Contact	MT4	Optional, if it's available, ON- alarm, OFF-OK;
X11	Spare	XI		MT4	
Q1	RO1 Ready	DO	Relay Output	MT4	
Q2	RO2 Running	DO	Relay Output	MT4	
Q3	RO3 Alarm	DO	Relay Output	MT4	

Q4	Spare	DO	Relay Output	MT4	
Q5	Spare	DO	Relay Output	MT4	
Q6	Spare	DO	Relay Output	MT4	
Q7	Spare	DO	Relay Output	MT4	
Q8	Spare	DO	Relay Output	MT4	
DO1	Spare	DO	TRAIC	MT4	
DO2	Spare	DO	TRAIC	MT4	
Ethernet Port	BACnet IP		IP Port	MT4	Need to enable / config manually by technician
T6	BACnet MSTP		RS485	MT4	Need to enable / config manually by technician
T14	ECM Fan Modbus Control		RS485	MT4	Enabled by default

APPENDIX

Modbus I/O

The EC fans in the unit are controlled via an RS-485 bus built into the unit controller using Modbus protocol.

- One or more ECM Fans:

Modbus Network Configuration

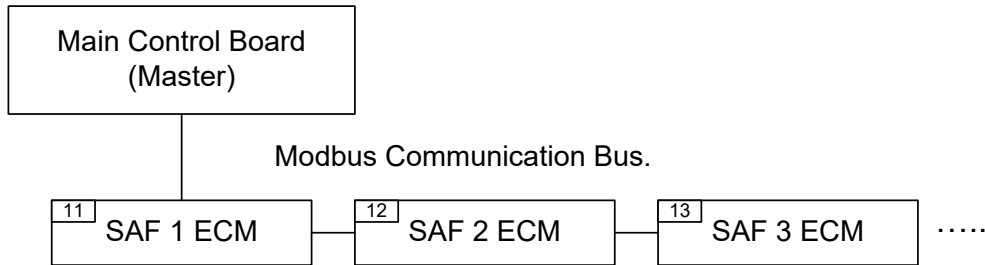



Daikin Applied Training and Development

Now that you have made an investment in modern, efficient Daikin equipment, its care should be a high priority. For training information on all Daikin HV1 and click on Training, or call 540-248-9646 and ask for the Training Department.

Warranty

All Daikin equipment is sold pursuant to its standard terms and conditions of sale, including Limited Product Warranty. Consult your local Daikin Applied representative for warranty details. To find your local Daikin Applied representative, go to www.DaikinApplied.com.

Aftermarket Services

To find your local parts office, visit www.DaikinApplied.com or call 800-37PARTS (800-377-2787). To find your local service office, visit www.DaikinApplied.com or call 800-432-1342.

This document contains the most current product information as of this printing. For the most up-to-date product information, please go to www.DaikinApplied.com.

Products manufactured in an ISO Certified Facility.