

ThinLine Horizontal Fan Coils

Type FCHC, FCHH and FCHR



Exposed Horizontal Cabinet



Recessed Horizontal Cabinet



Concealed Horizontal Model

Nomenclature and Certification	3	Performance Data	19
AHRI Certification	3	Two-Pipe Systems	19
Agency Listed	3	Four-Pipe Systems - Hot Water Preheat or Reheat (Standard or High Capacity)	20
Overview	4	Four-Pipe Systems - Steam Preheat or Reheat	21
The ThinLine Advantage	4	Performance Cooling and Heating – 2- and 4- Pipe	22
Features and Benefits	5	Air Volume Capacity Data	23
Options and Accessories	7	Electrical Data	24
Model Configurations	7	Physical Data	26
Options	8	Unit Data	26
Control Options	10	Unit Dimensions	27
Remote-Mounted Thermostats	10	Engineering Guide Specification	35
Sensors	12		
Customer-Supplied Controls	12		
Factory Valve & Piping Packages	13		
Control Valve Options	15		
Unit Selection	18		

Daikin Thinline Horizontal Fan Coils are intended for use in single zone applications. They are available in sizes from 200 to 1200 cfm. [Figure 2](#) and [Figure 3](#) describe the main features of these units and can be referred to for component placement. These units are available in two-pipe configurations with one hydronic coil, with or without electric heat for main or supplemental heating. They are also available in four-pipe configurations with a primary coil and a secondary reheat or preheat coil. A variety of factory-built piping packages are available, either factory or field-installed. Units are available with a variety of control options, including MicroTech® III controller board.

A choice of motors, PSC or ECM, is available. Fan Coil units can be provided with a fresh air damper option—manual or automatic.

AHRI Certification



Standard size units certified in accordance with the Room Fan-Coil Unit certification program, which is based on AHRI Standard 440.

Agency Listed



All standard units
All Canadian units

Figure 1: Nomenclature

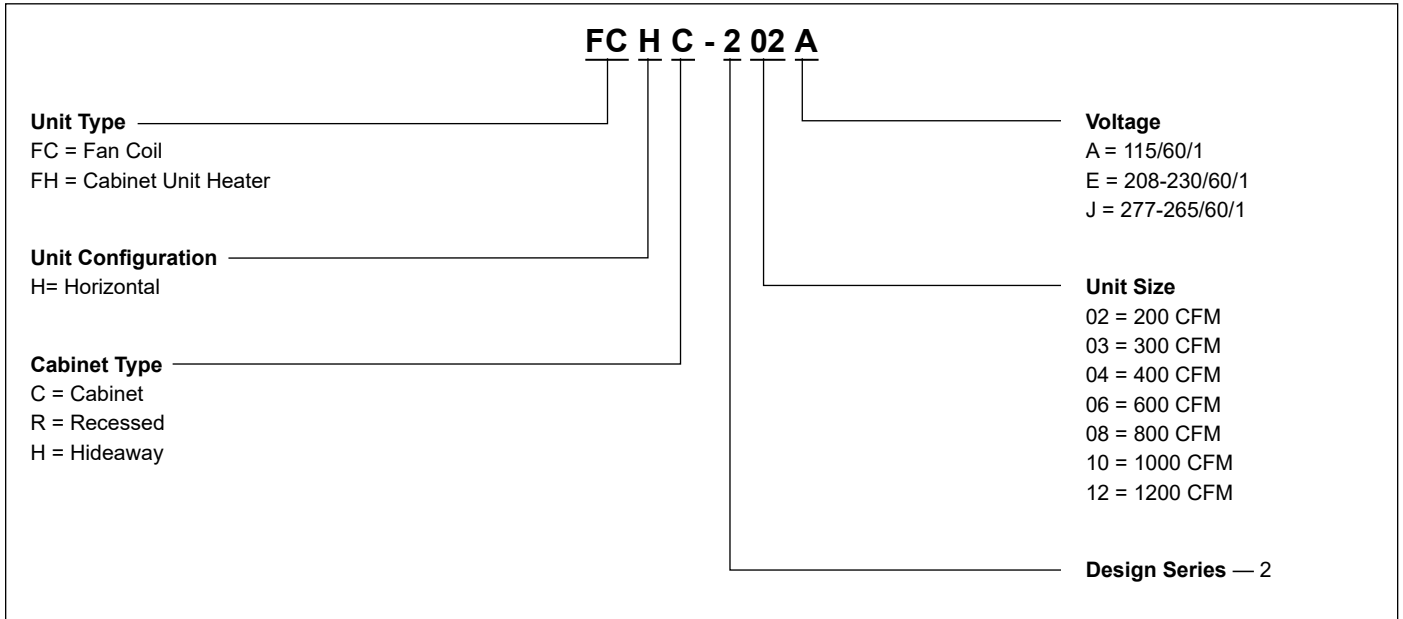

The ThinLine Advantage

ThinLine horizontal fan coils combine features most desired in a fan coil by building owners, specifying engineers and contractors alike. The result is a fan coil design that meets the needs of all three.

For building owners

ThinLine fan coils offer quiet and energy efficient operation. They fully comply with [ASHRAE 62.1-2010](#) standards for high indoor air quality. And they offer a range of control options including BAS controls that can enhance occupant comfort and reduce operating costs. These units are also easy to maintain, with easy access to filters, fan motors and control systems. Fully concealed, Recessed or Exposed type units are available. Tamper-proof style cabinets are offered. A total of five color options, both as standard and special requests are available for a variety of decor styles.

For specifying engineers

ThinLine fan coils provide great versatility. A variety of horizontal ceiling models are available with multiple arrangements and configurations.

- Coil options include two-, three-, and four-row primary coils to provide precise heating and cooling performance for any requirement. Separate, single-row standard or high capacity secondary heating coils (hot water or steam) are available in reheat or preheat arrangements. Preheat coils are also available with same or opposite-end coil connections.
- Multiple control options range from a simple wall or unit-mounted fan speed switch to a low-voltage interface board to a MicroTech controller board that can tie into most building automation systems. Non-communicating or communicating control options for LONTALK® and BACnet® are offered with the MicroTech option. Contact your Daikin representative for details.
- Discharge grille options include stamped or double-deflection louvers. Open return or ducted return air is available, as well as stamped louvers for cabinet type units. Rear or bottom returns, front and bottom supply locations are offered.
- Appearance options include cabinet units with a durable, powder paint finish and decorative ceiling panels for recessed units in Cupola White or Antique Ivory. Other colors such as Off White, Putty Beige and Soft Gray are available. Custom colors can be matched as a special item. Tamper-proof units are a selectable option, with special screw head that prevent unauthorized access to unit interiors.
- Units are ETL and cETL listed. Performance is AHRI certified.

For contractors

ThinLine fan coils feature Quick Ship options for fast delivery and a number of features that make installation fast and simple.

- Factory-mounted, wired and tested valve and piping packages for quick hookup to the building piping to reduce installation time. Packages can also be shipped loose with the unit for quick and easy field installation. Valve and piping packages are designed for entering water temperature sampling. This eliminates the need for inefficient bleed lines to sense automatic changeover on two-pipe units.
- Factory-mounted and tested controls minimize field setup. Depending on the option requested, controls can be wired with a 24 VAC transformer to provide a single-source power connection to the unit. Several options are available for wall-mounted thermostats and unit or wall-mounted sensors. All wall-mounted thermostat and zone sensors require only low-voltage control wiring from the device to the unit control box.
- Multiple convenient knockouts and easy bottom and end panel removal for hookup of electrical and piping connections minimizes field-labor time and cost.
- Opposite end connections minimize efforts for the replacement or retrofit process. Easy fan deck removal provides quick access for inspection, maintenance or repair.
- Both the main drain pan and optional secondary drain pan are easily accessed and removable for cleaning. Field reversible for ease of installation in every situation.

Figure 2: Model FCHC Features

Mixing Box Modules (Automated or Manual)

- Two-position fresh air damper control
- Full economizer option (with MicroTech)
- Top or rear fresh air inlet
- Rear or bottom return air inlet

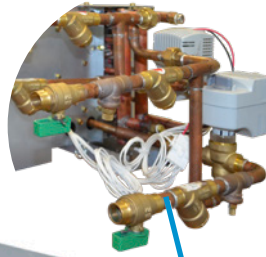

Diverse, Flexible Valve & Piping Packages

- Software selectable factory-mounted, wired and tested
- Or, factory-assembled and shipped loose
- Normally closed or open, two-position or modulating valves

Easily Removable Drain Pan & Motor Assembly

- For easy maintenance and service
- Sloped, galvanized drain pan standard
- Stainless steel drain pan for higher IAQ optional

Optional Secondary Drain Pan

- Included with factory-installed valve packages
- Easily removable
- Galvanized or stainless steel

Standard Color Options

- Antique White
- Cupola White

Special Color Options

- Off White
- Putty Beige
- Soft Gray

Multiple Control Options

- 3-speed switch, low voltage interface board or MicroTech® controller
- Remote thermostat
- 3-speed or staged fan control
- Factory-installed sensor options

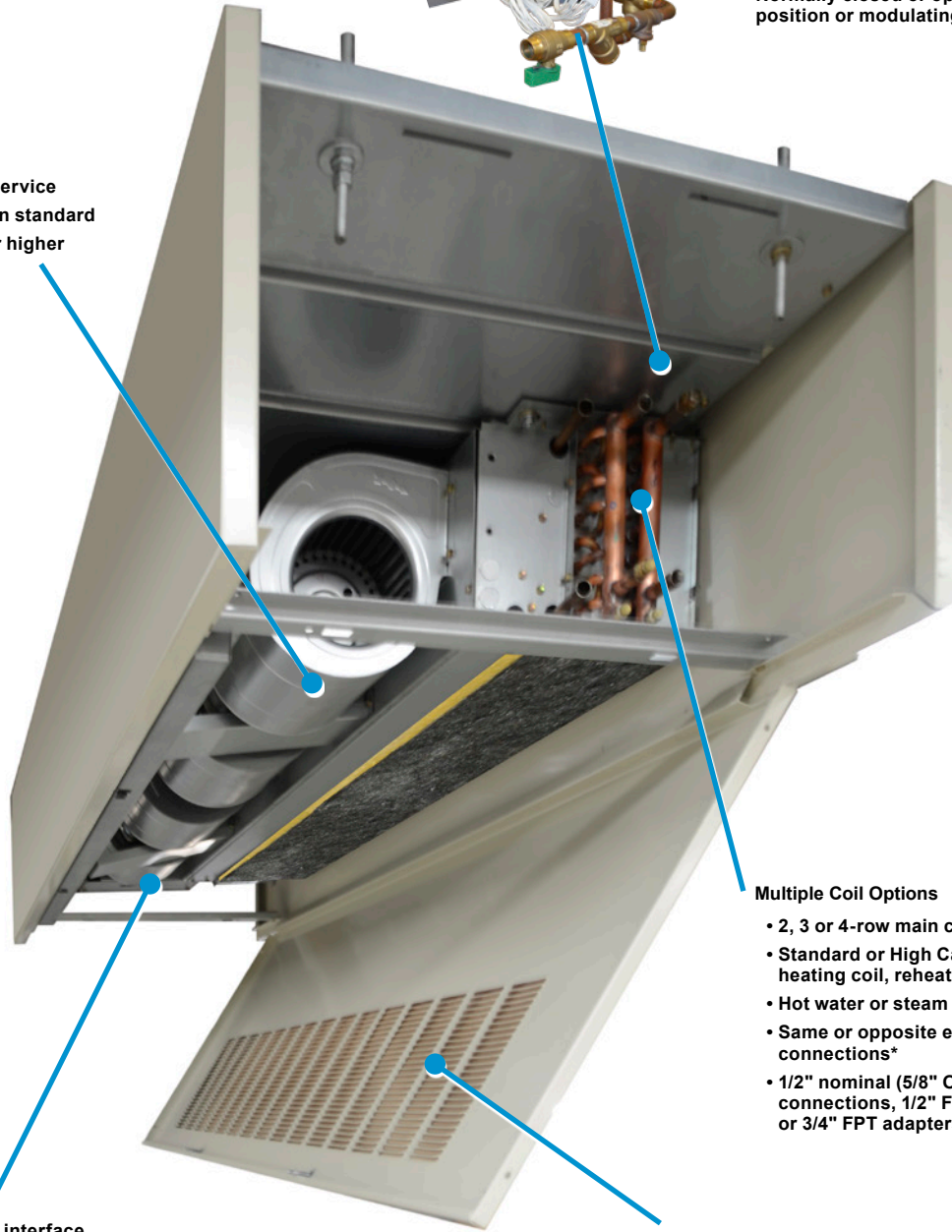

Multiple Coil Options

- 2, 3 or 4-row main coil
- Standard or High Capacity heating coil, reheat or preheat
- Hot water or steam
- Same or opposite end connections*
- 1/2" nominal (5/8" O.D.) sweat connections, 1/2" FPT adapters, or 3/4" FPT adapters.

Variety of Discharge and Return Options

- Duct collars
- Stamped grilles
- Double-deflection grilles

* Preheat coils available only in same-hand configuration

Figure 3: Model FCHH with Return Plenum Features

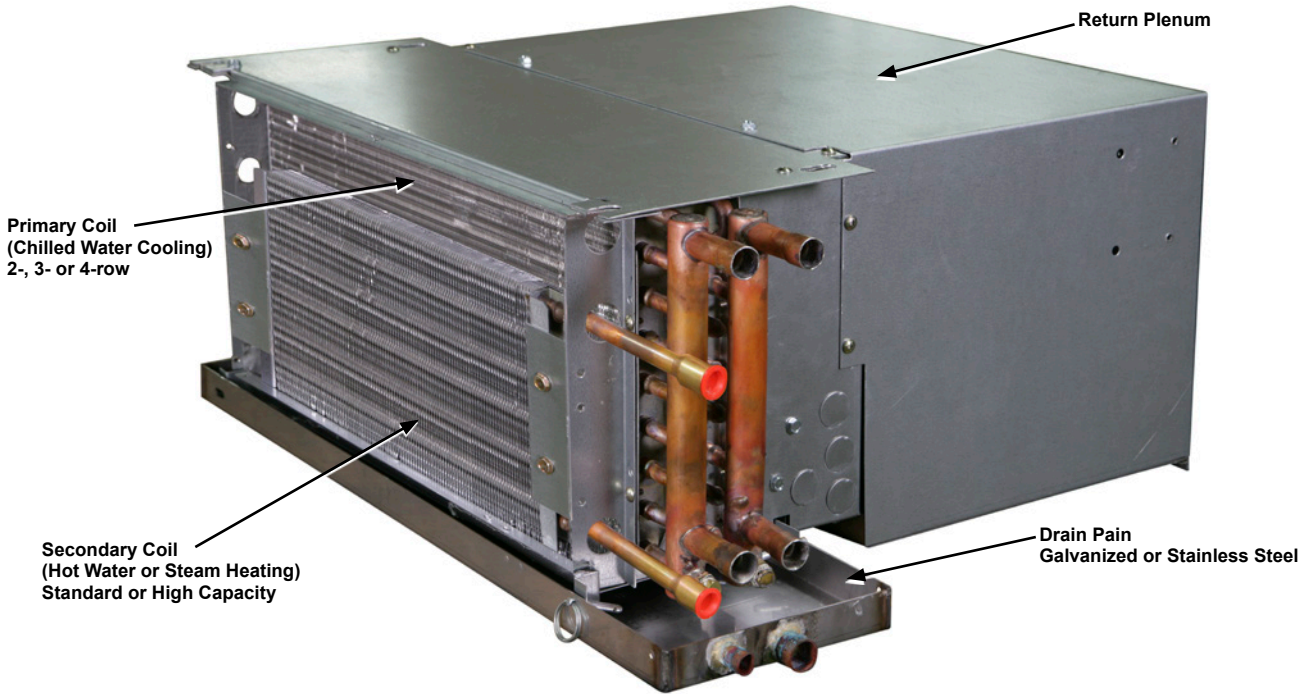

Model Configurations

Hideaway Units, Model FCHH



Concealed above-ceiling type fan coils can be supplied with or without factory-installed plenum. The low profile of a hideaway unit without a plenum makes it a perfect fit for applications where height is at a premium, for example drop-ceilings or over-closet projects. The return plenum is provided with an integral filter frame which is capable of carrying either 1" throwaway filter (MERV4), 1" permanent steel-mesh washable filter or higher efficiency filters to be used with ECM motors: 1" MERV8 and 1" MERV13 filters. Plenums may be supplied with rear or bottom return openings. Return connections are equipped with factory-installed duct collars. Open returns are also available. Supply connections are located at the unit front and equipped with duct collar for easy ducting. The plenums are made of heavy-duty steel and insulated with ½" thick Tuf-Skin® fiber glass insulation suitable for air stream applications. Optional ¼" antimicrobial-treated closed-cell insulation is software-selectable.

Cabinet Units, Model FCHC



Exposed ceiling type fan coils can be provided in a variety of attractive cabinet options suitable for any décor style, including 5 software-selectable paint colors. These fan coils are ideal for hotels, apartments, colleges, dormitories, etc. Rear and bottom return, front and bottom supply options are available. Return opening with integral filter frame may be provided in standard stamped louver option, open return or even with a duct collar. Discharge opening is offered with a stamped or double-deflection louver or with open or duct collar option. Cabinets are made of heavy-duty steel and insulated with ½" thick Tuf-Skin® fiber glass insulation suitable for air stream applications.

Optional ¼" antimicrobial-treated closed-cell insulation is software-selectable. Cabinets are of generous size allowing for all necessary appurtenances, including factory-installed controls and piping packages, to be covered and easily accessible. Bottom panel is equipped with a large-size hinged door providing easy access to components and simplifying maintenance process. Units with bottom discharge use two hinged doors and an enlarged bottom panel.

Recessed Units, Model FCHR



Fully- or partially recessed fan coils are available. Unpainted galvanized-steel finish or painted cabinet units will be supplied with a field-mounted fixed trim flange or floating ceiling panel to provide smooth transition to drywall ceiling. Recessed units with front discharge are provided with floating panel capable of telescoping 1.5" in height. These ceiling panels include bottom return with a filter frame and may be provided for back returns (ducted or open) as well. The panels are equipped with a large-size hinged door providing easy access to components and simplifying maintenance process. Units intended for use with bottom discharge will be supplied in painted cabinets with fixed ceiling trim flanges coated in paint of the same color as the unit.

For applications with height restrictions less than 14.5" cabinet units with fixed trim accessory is recommended. Contact your Daikin representative for more details.

Options

Cabinet Color Options

Exposed units are shipped in the standard color of Antique Ivory. Optional colors include: Cupola White, Off White, Putty Beige and Soft Gray. Custom colors are available as a special option. Please contact your Daikin representative. For details of paint colors and finishes, refer to Daikin publication Form [2F-1188](#). Metal samples are available upon request.

Tamper-proof Cabinet Option

This option can be factory-installed on cabinet units to prevent access to unit controls and unauthorized removal of cabinet panels. It includes torx head screws for cabinet panels. Stamped grille for return and supply air is standard with tamper-proof models.

Condensate Overflow Switch Option

With proper mounting, the condensate overflow switch will detect water collecting in the primary drain pan before an overflow can occur. This is a N.C. low voltage switch that opens when water levels rise and closes when water is no longer present. For units without MicroTech controllers, the switch should be field-wired to a controller to facilitate the fan and/or control valve shut-down when condensate starts collecting in the drain pan.

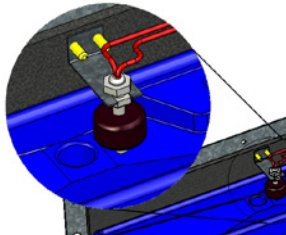

Discharge (supply) Air Grille

A stamped-steel supply air grilles are standard for both front and bottom discharge. Also available is a double deflection grille for front discharge units.

Motor option

Horizontal ThinLine fan coil units are equipped with standard three-tap Permanently-Split Capacitor (PCS) motors for 115/1/60, 208-230/1/60 and 277/1/60 volt applications. Optional brushless DC Electronically Commutated Motors (ECMs) are available for the above voltage ranges. These motors are also used for high-static applications. All motors are connected to a unit-mounted electric panel with Quick-Connect fitting for ease of maintenance.

Fresh Air Damper Options (Automatic or Manual)

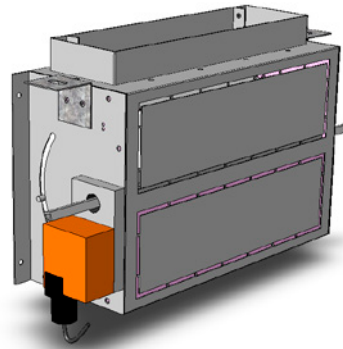

The fresh air damper module with top or rear fresh air inlets is available for concealed, recessed or exposed units. Fresh Air Damper control can be automated or manual. Automatic options include a 2-position control or a full economizer option (MicroTech controller only).

Manual Damper – The manual damper is field-adjustable to allow a zero to 25 percent fresh air position.

Auto Two-Position Damper – The auto two-position damper is factory set at 25 percent when open. The damper can be set in the field to allow a zero to 50 percent fresh air position.

Economizer Damper – The economizer damper is accompanied by a factory-installed and wired modulating actuator. The damper is factory set at 25 percent default minimum and 100 percent maximum opening. The damper is field adjustable using MicroTech III to allow a zero to 100 percent fresh air.

Electric heater options

Single-point power connection electric heaters are available for the following applications: 1) as total source of heat for the unit; 2) as supplementary (intermediate) source of heat between the seasons. Dual power connections are available when a motor and a heater are of different voltage.

The heater coils are fabricated of Nickel-Chromium high-grade resistance wire and are placed directly in front of the blower outlet. High limit thermal cut-out protects the heater in the event of insufficient air delivery.



Total electric heat

Primary coil is used for cooling only. A single-stage electric heater provides total heat for the system. Individual room control can be provided for manual or automatic changeover.



Intermediate (supplementary) electric heat

Primary coil is used for cooling or heating depending on the season and demand. In summer, while cold water is circulating in the system the fan coil unit will be cooling the space. In winter, the circulating hot water will make the fan coil unit heat the space. Between seasons, when the space control calls for heating, it will be provided by the electric heater.

Control Options

Manual 4-Position Fan Switch



Several styles of the four-position fan switch (OFF, High, Med, Low) are available for unit-mount, remote- or wall-mount. The remote-mount option operates on low-voltage or line-voltage power and can be provided with a factory-

mounted, low-voltage interface board, which contains (3) 24-volt relays with line-voltage contactors and terminal connections. The transformer is factory-installed and wired. The unit-mounted option operates on line voltage.

Sequence of operation

- **OFF:** Fan is turned OFF. The two-position, motorized fresh-air damper, when supplied, is closed.
- **High, Medium, Low:** Fan runs continuously at the selected speed. The two-position, motorized fresh-air damper, when supplied, is opened.

Remote-Mounted Thermostats

Analog Thermostats

MT155 Thermostat



The MT155 series thermostat provides ON-OFF control for low-voltage or line-voltage valves and fan motors. It is remote-mounted. Options include manual or automatic changeover and three-speed fan control for continuous or cycling fan operation.

Analog Thermostat with 3-Position Fan Switch

This option combines the three-position fan switch with an electronic analog thermostat. For two-pipe systems with a factory installed valve package, it can be provided with an automatic switch (MTB-155) to change from heating, or cooling. Or changeover can be a manual switch (MTA-155).



Sequence of operation

Two standard control options are available:

- **Continuous fan and ON-OFF valve cycle operation:** The thermostat cycles the valves ON and OFF. The fan runs continuously at the manually selected fan speed.

- **ON-OFF fan and ON-OFF valve cycle operation:** The thermostat cycles the fan from the manually-selected fan speed to OFF and it cycles the valves ON and OFF.

When the system switch is in the OFF position, the fan coil system, including the fan, is shut OFF.

Digital Thermostats

Daikin offers a broad range of remote wall-mounted digital thermostats with the capability to control ON-OFF, 3-wire floating and proportional modulating actuator, and Normally-Closed or Normally-Open valves. See [Table 1](#). For more information, refer to the Daikin publication [ED 18513-1](#) and Installation Manuals for the specific thermostat (also see [IM 1152](#)).



MT158 and MT168 Thermostat-Controllers with Digital Display

Series MT158 and MT168 microprocessor-based thermostat controllers combine a proportional integral (PI) control algorithm with adaptive logic.



Heating and cooling outputs for the MT158 are individually configurable for three-wire floating control valves or ON/OFF valves in the Normally-Open (NO) or Normally-Closed (NC) modes.

Heating and cooling outputs for the MT168 provide 0-10 Vdc or 4-20 mA. An integrated, three-speed fan control switch is line-voltage capable to allow direct connection to the fan motors. A manual or automatic changeover is provided with remote setback capability from a time clock or facility management system. Features include a Fahrenheit or Celsius digital display and built-in purge cycling which assists the controller to determine if the system is supplying hot water or cooling.

Standard Control Mode

- **ON-OFF fan cycle operation and modulating (or ON-OFF) valve operation.** The controller cycles the fan from the manually selected fan speed to OFF. The controller modulates the valves or, on the MT158, dip-switches can be set to cycle the valves ON and OFF. Used for remote-mount thermostats or with a remote room temperature sensor.

T170 Thermostat with Digital Display

Two thermostats are offered for remote installation only: TA170 for three-speed fan control and TB170 for staged fan operation. Both thermostats are used for ON-OFF control of low- or line-voltage valves with auto changeover. For detailed information refer to IM 1152



T180 Programmable Thermostat

Daikin offers two different 7-Day Programmable Digital Heating/Cooling Thermostat with constant fan or Fan cycled, ON/OFF Valve Control depending on the fan speed control. The thermostat interface contains buttons for use in navigation to accompanying menus/screens and for performing specific operations. Detailed installation instructions and modes of operation can be found in IM 1152



Table 1: Thermostat Summary Table

Thermostat Type	Model	Software Tabs
ON/OFF Switch with 3-speed Fan Switch with Hi/Med/Lo Settings and Switched Auxiliary Connection	MTE-155	Accessories
2-Pole Dead-Band Auto-Changeover Thermostat with Manual ON-OFF System Switch and Manual 3-Speed Fan Switch, ON/OFF Valve Control	MTB-155	Accessories
Thermostat with Manual Heat-OFF-Cool System Switch and Manual 3-speed Fan Switch, ON/OFF Valve Control	MTA-155	Accessories
Digital Thermostat 24 vac/120-277 vac with 3-speed Fan Control (Continuous or Fan Cycle)	MTA-170	Accessories
Digital Thermostat with 7-Day Programmable, 24 vac/120-277 vac with 3-speed Fan Control (Continuous or Fan Cycle)	MTA-180	Accessories
Digital Thermostat 24 vac/120-277 vac with Staged Fan (Continuous or Fan Cycle)	MTB-170	Accessories
Digital Thermostat with 7-Day Programmable, 24 vac/120-277 vac with 3-speed Fan Control (Continuous or Fan Cycle)	MTB-180	Accessories
Digital Thermostat with Dead Band Auto-Changeover for Heating/Cooling. ON/OFF or 3-wire Floating Valve Control and 3-speed Fan Switch	MTB-158	Accessories
Digital Thermostat with Dead Band Auto-Changeover for Heating/Cooling, ON/OFF, and Manual 3-speed Fan Switch	MTA-158	Accessories
Digital Thermostat with Auto-Changeover, Dead-Band, 0-10 vDC Proportional Modulating Valve Control.	MTB-168	Accessories
Digital Thermostat with Auto-Changeover, Dead-Band, 0-10 vDC Proportional Modulating Valve Control, and Manual 3-speed Fan Switch	MTA-168	Accessories

*Can be field-mounted on units with Low Voltage Interface Boards, refer to IM 1089

Low Voltage Interface Board

The Low-Voltage, Interface Board (LV board) is used with any remote (wall-mounted) Daikin thermostat. With a field-supplied controller, it can also be used with a BAS (Building Automation System) control where low voltage is needed to operate a fan coil.

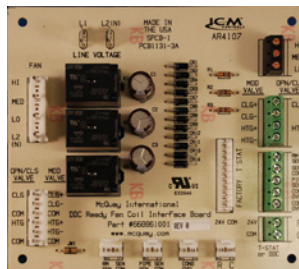

The LV interface board includes:

- Three 24-volt relays with line voltage contactors to operate fan motor speeds
- A factory wired and installed transformer
- Terminal connections for interfacing to:
 - An optional wall-mounted thermostat
 - Low-voltage actuators for heating and cooling valves
 - A return air sensor
 - A pipe temperature sensor for changeover from heating to cooling on two-pipe systems
 - An optional condensate overflow switch

MicroTech Controllers

ThinLine fan coils can be provided with unit-mounted MicroTech controllers and multiple unit- or room-mounted sensors.

MicroTech controllers can only be used with remote room sensors (described below) and not with remote thermostats.

A MicroTech controller is able to operate in either a stand-alone non-communicating environment or a communicating environment. To operate in a communicating environment, a board named *communication module*, is installed on the unit controller. There are two types of communication modules available with MicroTech controllers: LonWORKS and BACnet MSTP.

Unit controller sequences and controls: single- or multi-speed fans, two-position hydronic cooling and heating valves, floating three-wire hydronic cooling and heating valves, electric heat, ventilation dampers or economizers.

Unit controllers and/or I-O expansion boards have inputs for room or return temperatures, temperature setpoint adjustments, fan speed switches, entering water temperatures, discharge air temperatures, changeover auto switches, low temperature detection, emergency shutdown detection, condensate overflow detection, dirty air filter detection and occupancy. All sensors are software selectable and the controller is configured based on the selection.

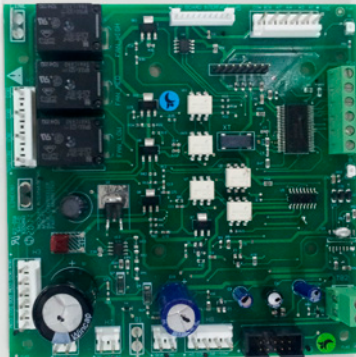

Sensors

Remote-mounted Room Temperature Sensor with Timed Override

The Basic Sensor provides simple room temperature sensing all applications. Unit status is provided through a flashing LED located on the sensor while timed tenant override and fault reset are provided through the Override button.



Room Temperature Sensor with Setpoint Adjustable Module and Fan Speed Control

The Digitally Adjustable sensor provides the ultimate of temperature control and display, simple user interface, alarm annunciation, and alarm reset. The easy to read LCD clearly identifies the system operating mode including occupied/unoccupied mode, fan operation and control, unit status, timed override status, alarm annunciation, and energy savings mode through a series of recognizable icons. Tactile response buttons initiate adjustments for temperature set points, system mode, fan mode, occupancy, tenant override and fault reset functions. The large numeric LCD will display space temperature (°F or °C) with the corresponding setpoint conditions. This sensor is designed for use with BACnet or LonWORKS applications. However, it can also be installed as a standalone sensor using factory default set points.



Customer-Supplied Controls

Your Daikin representative can work with engineers and/or contractors to factory install and wire other manufacturers' DDC controllers on the fan coil. Contact your local Daikin sales representative for assistance with your specific project.

Factory Valve & Piping Packages

Factory valve and piping packages are available for both two-pipe and four-pipe systems with either right or left hand connections. Four-pipe systems can be configured with the heating and cooling connections on the same or opposite sides of the unit. Packages can be either factory-installed or factory-assembled and shipped loose with the unit. All factory-assembled packages are fully leak tested. Units are also available without valve and piping packages in either a right-hand or left-hand configurations.

Factory-installed packages are welded to the coil and wired to the unit control box, MicroTech controller or LV Interface Board. For field-installed packages, chilled and hot water pipes are the only field connections required. Piping is 1/2" nominal copper (5/8" OD).

Figure 4: Four-pipe Deluxe Valve and Piping Package

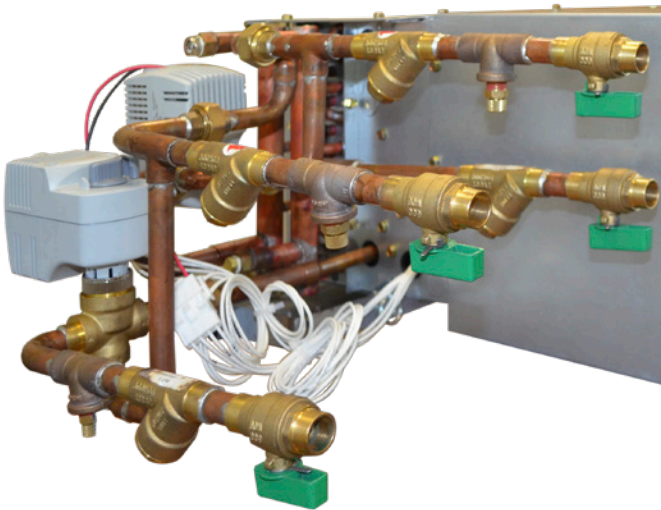

Pre-determined field connection points are located for easy access. The installing contractor can pre-pipe the building water connections before the units arrive on the jobsite. A label clearly identifies chilled and hot water connection points on every unit.

All chilled water piping and components are located to allow condensate to drain into the secondary drain pan supplied with the valve package. Insulation of the factory piping package is not required.

Available Packages

All factory-installed valve packages are flexible, configurable and fully software-selectable in our DaikinTools™ selection program. Custom valve packages are available also. Numerous piping packages are available to match design configurations. Additional components can be added to meet exact requirements, including P/T ports, unions, and flexible stainless steel hoses.

Shut-Off Only Packages

Shut-Off Only piping packages provide interconnecting copper piping and shut-off ball valves for ease in connecting supply and return lines to the unit. Four-pipe packages include a venting valve for the preheat or reheat coil. Primary coils on all units have an integral venting valve.

Figure 5: Shut-Off Only Package

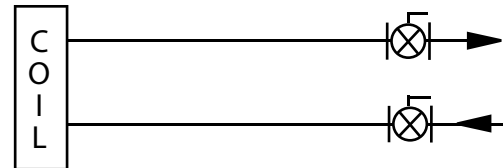

(See Figure 11 for components key)

Basic Packages

Basic valve and piping packages add control valves to the Shut-Off Only package. All Daikin control valves are factory-mounted in the supply water pipe. See [Control Valve Options on page 15](#) for more information on the variety of control valves available.

Figure 6: Basic Package

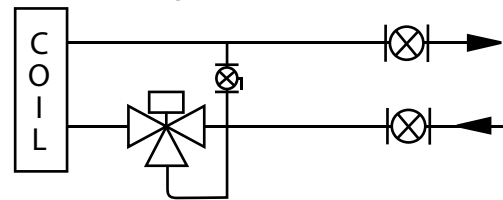

(See Figure 11 for components key)

Enhanced Packages

Enhanced valve and piping packages add a strainer to the Basic package supply water pipe. The strainer is attached to the supply water pipe at the coil connections. The strainer body is cast brass construction with a stainless steel mesh that is easy to remove for cleaning.

Figure 7: Enhanced Package

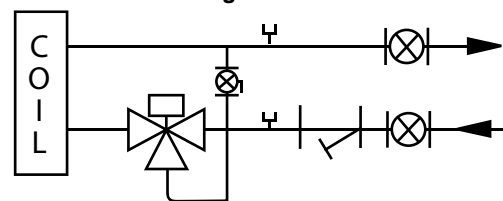

(See Figure 11 for components key)

Premium Packages

Premium valve and piping packages replace the Basic package a ball valve in the return line with a manual or automatic circuit setter. The manual circuit setter is also known as a manual flow control valve. The auto circuit setter acts as both a flow setting device and a shut-off valve. It allows water flow through the fan coil to be set quickly and accurately. The circuit setter includes a cartridge within the valve body that is sized to allow a specific flow rate through the coil without any action required by a system piping balancer.

P/T ports are included, which are used to measure the temperature or pressure drop across the valve. This pressure drop can be compared to factory supplied tables that relate the pressure drop to a specific flow rate. The manual circuit setter valve also has a memory stop so that the correct setting can be found quickly.

Figure 8: Premium Package

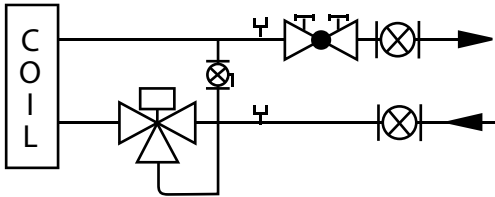

(See Figure 11 for components key)

Figure 9: Bypass Bleed Line

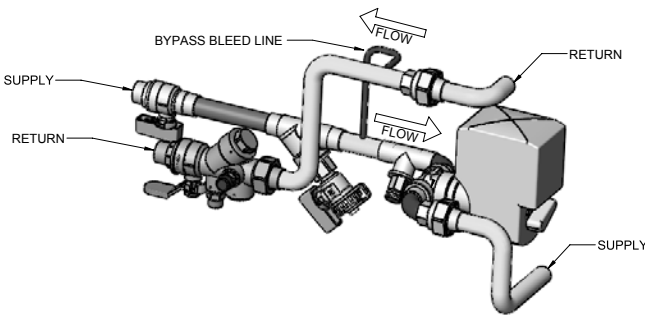

NOTE: A bypass bleed line is installed on all factory provided fan coil valve packages with a 2-way control valve to prevent stagnation of water near the changeover switch (aqua-stat) or changeover sensor (10K pipe sensor). The bleed line allows 3 – 4 gpm of flow to bypass the coil which is necessary for the proper function of the automatic changeover system. All valve packages, cooling and heating, with a 2-way control valve automatically include the bypass bleed line. If the bleed line is unwanted, it may be crimped by the installing contractor to prevent bypass flow.

Deluxe Packages

Deluxe valve and piping packages add a strainer to the Premium package. The strainer is available with or without an optional draining (blow-off) valve.

Figure 10: Deluxe Package

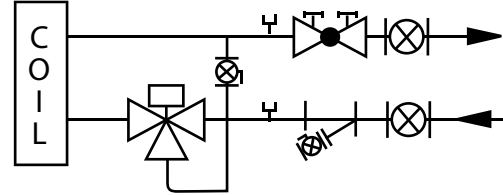

(See Figure 11 for components key)

Figure 11: Components Key for Schematics

		Manual Shutoff Ball Valve: Water shut-off. Handle rotates 90 degrees.
		Manual Shutoff Ball Valve with Memory Stop: Used on return line for limiting water flow.
		2-Way, N.C., ON/OFF Valve, Spring Return: Turn ON or OFF water flow to the coil in response to 24V or line voltage signal
		3-Way, N.C., ON/OFF Valve, Spring Return: Bypass water flow away from coil in response to 24V or line voltage signal. Includes fixed orifice for balancing.
		2-Way Modulating Valve (3-wire or proportional): Modulates water flow in response to 24V signal.
		3-Way Modulating Valve (3-wire or proportional): Modulates or bypass water flow in response to 24V signal. Includes fixed orifice for balancing.
		PT Port: For connecting a pressure or temperature gauge.
		Y-Strainer: Removable screen filters out small particles from supply line during normal system operation.
		Manually Adjustable Circuit Setter with Shutoff: Pressure-dependent, ball-type, manual flow control.
		Cartridge-Type, Auto-Fixed Circuit Setter: Pressure-compensated, automatic fixed-flow control.
		Union: For easy removal of piping from coil.
		Bypass Balancing Valve: Adjustable balancing of water flow through the bypass circuit on a 3-way control valve.

Note: Daikin 3-way valves are equipped with a fixed balance orifice in the bypass line, eliminating the need for a separate balancing valve

Control Valve Options

Except for Shut-off Only packages, all valve and piping packages include control valves for controlling water flow. All Daikin control valves are factory assembled and mounted in the supply water pipe downstream of the coil. Several options are available:

Two-Way/Two-Position Valves

These valves will be either Fully-Open or Fully-Closed in response to a line voltage (115, 208-230 or 265-277 VAC) or 24 VAC signal from the Daikin thermostat or controller. Some means of relieving pump head pressure should be applied when two-way valves are selected. Normally-Open or Normally-Closed valves are available, both spring-return type.

Three-Way Two-Position Valves

These valves either allow full water flow through the coil or divert the flow through a bypass line. The valves respond to a line voltage (115, 203-230 or 265-277 VAC) or to 24 VAC signal from the Daikin thermostat or controller. All standard three-way valves come with a fixed-balance orifice in a bypass line to compensate for flow balancing in the bypass position, eliminating the need for an additional balancing valve. Normally-Open or Normally-Closed valves are available.

Two-Way Modulating Valves

These valves modulate the water flow through the coil in response to a signal from the Daikin thermostat or controller. Standard Daikin modulating valves are three-wire floating point equal percentage valves. Zero to 10 VDC proportional valves are also available. The modulating valves are factory mounted in the supply water pipe upstream of the coil.

Three-Way Modulating Valves

These valves modulate water flow through a coil in response to a signal from a Daikin thermostat or controller. Three-way valves allow water that is directed through the coil to mix with water that is directed through the bypass line. This mixture exits through the leaving water pipe. Modulating valves are three-wire, floating-point equal percentage valves or 0-10 VDC proportional. The modulating valves are factory mounted in the supply water pipe upstream of the coil.

Selecting Correct Size Modulating Valves

DaikinTools software automatically selects the best modulating valve size for the unit and coil being considered. By combining the [AHRI](#) performance data, the coil flow rate and the DP across the water coil, the water coil Cv is calculated and the best matching modulating port size is selected. Valve and piping packages can easily be configured and automatically selected using Daikin Tools.

Figure 12: Factory-Installed Valve & Piping Packages (Right-Hand Shown)

Connecting Pipe Locations: 2-Pipe Cooling or Heating

Deluxe Package shown

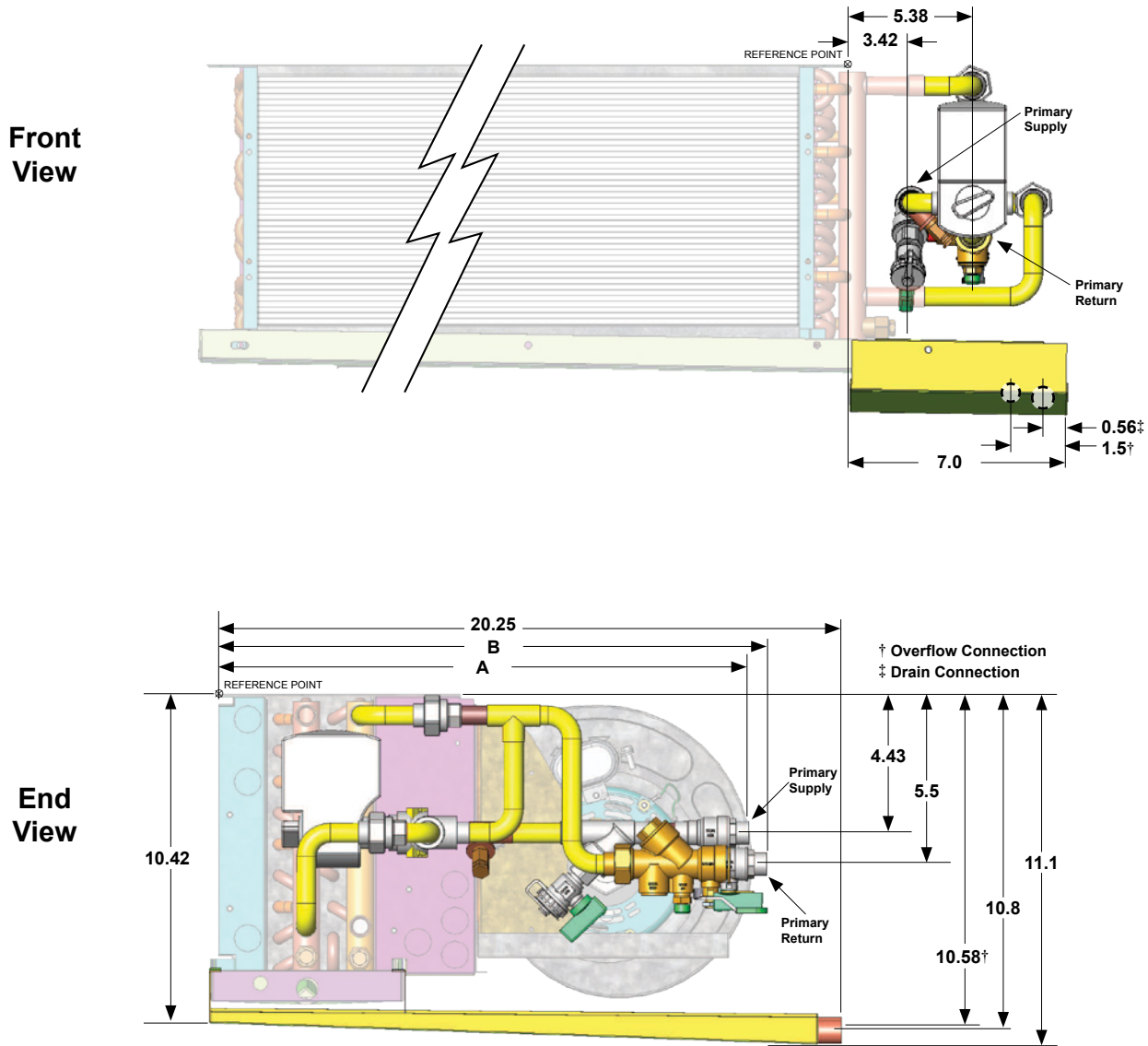

Name	Component Description	Primary Package Connections from Reference Point (2- & 3-row Coil)	
		Supply (A)*	Return (B)*
Basic 2W	2Way control valve, shut-off valves	12.2	16.2
Basic 3W	3Way control valve, shut-off valves	12.2	17.0
Enhanced 2W	2Way control valve, shut-off valves, strainer	15.8	16.3
Enhanced 3W	3Way control valve, shut-off valves, strainer	15.8	17.0
Premium 2W, auto flow	2Way control valve, shut-off valves, auto flow-setter	12.3	15.8
Premium 2W, manual flow	2Way control valve, shut-off valves, manual flow-setter	12.3	16.6
Premium 3W, auto flow	3Way control valve, shut-off valves, auto flow-setter	12.2	14.8
Premium 3W, manual flow	3Way control valve, shut-off valves, manual flow-setter	12.2	15.6
Deluxe 2W, auto flow	2Way control valve, shut-off valves, strainer, auto flow-setter	15.8	15.8
Deluxe 2W, manual flow	2Way control valve, shut-off valves, strainer, manual flow-setter	15.8	16.6
Deluxe 3W, auto flow	3Way control valve, shut-off valves, strainer, auto flow-setter	12.2	14.8
Deluxe 3W, manual flow	3Way control valve, shut-off valves, strainer, manual flow-setter	12.2	15.6

NOTE: For 4-row Primary Coils add 1" to the dimensions A and B shown

Figure 12 continued: Factory-Installed Valve & Piping Packages (Right-Hand Shown)

Connecting Pipe Locations: 4-Pipe Cooling and Heating, Same-side

Deluxe Package shown

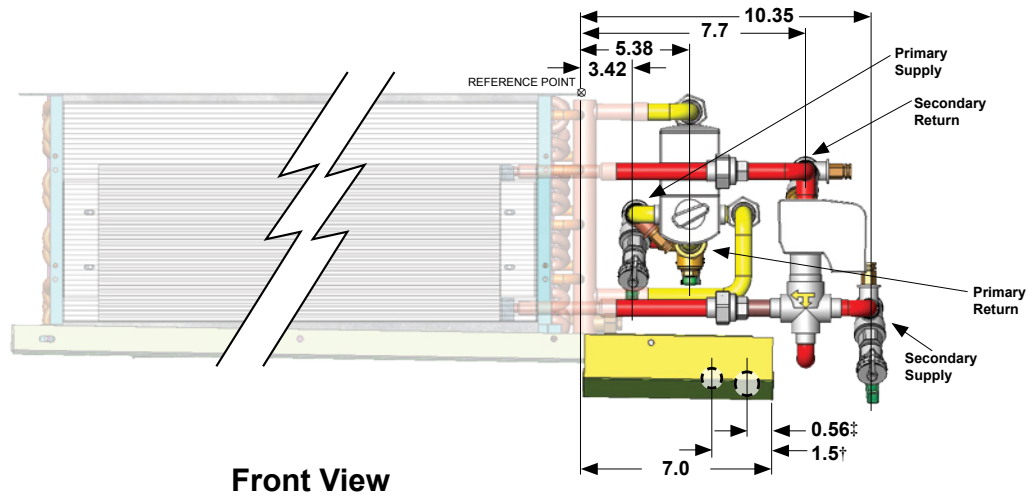

Front View

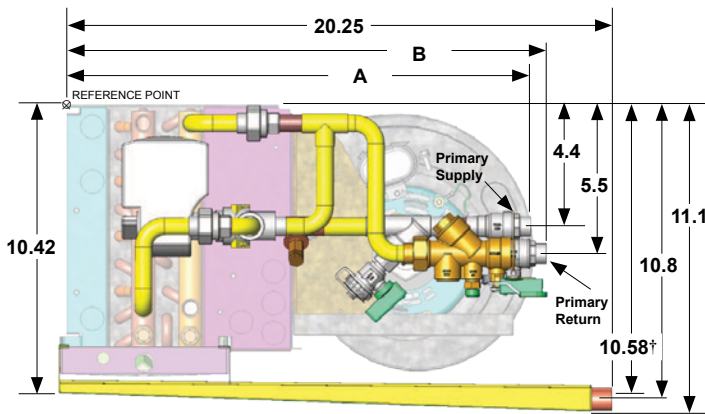

Primary Piping End View

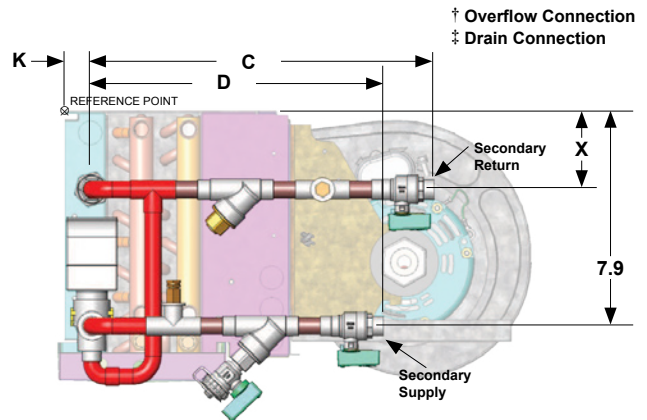

Secondary Piping End View

Name	Component Description	Primary Package Connections from Reference Point (2- & 3-row Coil)		Secondary Package Length		Secondary Coil Connection from Reference Point			
		Supply (A)*	Return (B)*	Return (C)	Supply (D)	Preheat (K)	Reheat (K)	High Capacity (X)	Standard Capacity (X)
Basic 2W	2Way control valve, shut-off valves	12.2	16.2	6.5	7.1	4.53	1.03	0.8	2.8
Basic 3W	3Way control valve, shut-off valves	12.2	17.0	9.0	7.1				
Enhanced 2W	2Way control valve, shut-off valves, strainer	15.8	16.3	6.5	10.7				
Enhanced 3W	3Way control valve, shut-off valves, strainer	15.8	17.0	9.0	10.7				
Premium 2W, auto flow	2Way control valve, shut-off valves, auto flow-setter	12.3	15.8	6.1	7.1				
Premium 2W, manual flow	2Way control valve, shut-off valves, manual flow-setter	12.3	16.6	10.6	7.1				
Premium 3W, auto flow	3Way control valve, shut-off valves, auto flow-setter	12.2	14.8	5.1	7.1				
Premium 3W, manual flow	3Way control valve, shut-off valves, manual flow-setter	12.2	15.6	9.6	7.1				
Deluxe 2W, auto flow	2Way control valve, shut-off valves, strainer, auto flow-setter	15.8	15.8	6.1	10.7				
Deluxe 2W, manual flow	2Way control valve, shut-off valves, strainer, manual flow-setter	15.8	16.6	10.6	10.7				
Deluxe 3W, auto flow	3Way control valve, shut-off valves, strainer, auto flow-setter	12.2	14.8	5.1	10.7				
Deluxe 3W, manual flow	3Way control valve, shut-off valves, strainer, manual flow-setter	12.2	15.6	9.6	10.7				

NOTE: For 4-row Primary Coils add 1" to the dimensions A and B shown

To achieve an efficient fan coil system, accurate system design and proper equipment selection is necessary. Variations, limitations/control of fan coil systems, design conditions and design load calculations are not described in detail in this catalog. More detailed information may be found in the [ASHRAE](#) Guide. This catalog contains AHRI-certified ratings and application ratings for ThinLine fan coil units from which a design engineer can make initial unit selections to meet system requirements.

A mechanical system designer must select the unit types best suited to the overall system before the actual unit sizes can be determined. The factors that generally influence this decision are: intended building usage, building layout, architectural and aesthetic values, economics, geographical location, and type of maintenance service available. The general results may be a mixture of unit types within a given system. Daikin Applied manufactures fan coil units to meet many needs including ThinLine, HiLine and Large Capacity models. For Daikin product information, please go to www.DaikinApplied.com.

Basic Design Data

Prior to selecting individual unit sizes, a design engineer must fix or determine the following factors:

- Inside and outside wet and dry bulb design temperatures
- Total and sensible heat gains and losses of the area to be served
- Ventilation air
- Properties of the heating and cooling medium
- Available electric power service
- Any special design requirements of the building or system

Unit Size

The capacity ratings presented in this catalog are provided for initial unit selection only. Water cooling and heating capacities, unit air flow, static pressure and glycol solutions are all incorporated into the program to provide the best possible selection. Consult your Daikin representative for a selection tailored to specific applications.

Unit sizes for the ideal system should be selected by calculating peak load requirements due to unusually high occupancy or severe climatic conditions and with fans operating at high speed. Ordinary day-to-day cooling and heating requirements are then achieved at low and medium speeds.

The initial unit selection should be checked for air volume in the design system and the cooling capacities checked against actual operating conditions. While units selected on the basis of sensible load will generally meet the total cooling load, total load should be checked in all cases.

The unit size is generally selected on the basis of matching the sensible cooling capacity of the unit with the calculated requirements when operating at high speed.

Coil Types

Standard coils are designed to meet both cooling and heating requirements in a typical system. Two additional levels of enhanced primary coils are available to meet the total and sensible requirements of any application.

Heating requirements for two-pipe systems are generally met by employing the same water flow rate as cooling and adjusting the entering hot water temperature to obtain a matching unit heat output at low fan speed.

Four-pipe systems are generally designed by specifying the flow rate through the separate heating coil to meet the required heat load with the fan operating at the desired fan speed. Daikin offers two coil options for preheat and one option for reheat.

Two-Pipe Systems

All performance measured on high speed tap, 115 V, at 0.05" ESP for hideaway fan coils and 0.0" ESP for cabinet fan coils. Cabinet units were tested with bottom return/front discharge configurations.

Cooling performance is based on 80/67°F (27/19°C) entering air temperature, 45°F (7°C) entering chilled water temperature with a 10°F (5.5°C) temperature rise.

Heating performance is based on 70°F (21°C) entering air temperature, 180°F (82°C) entering hot water temperature with a 30°F (17°C) temperature drop.

For other conditions and/or unit configurations, refer to DaikinTools™ selection program or talk to your local Daikin representative.

Table 2: Cooling and Heating Performance – Two-Pipe Systems

Unit Model	Unit Size	Nominal Air Flow SCFM	Number of Primary Rows	Number of Circuits	Cooling Performance		Heating Performance	Chilled Water Flow	CW Pressure Drop
					Total, MBH	Sensible, MBH	MBH	GPM	Ft
FCHH no plenum, free discharge fan	02	200	2	4	5.1	4.7	21.7	1.0	0.2
			3	4	8.9	7.0	28.1	1.8	1.0
			4	4	10.8	7.7	29.3	2.2	1.9
	03	300	2	4	5.5	5.1	25.0	1.1	0.3
			3	4	10.7	8.5	32.9	2.2	1.4
			4	4	12.8	9.3	35.0	2.6	2.3
	04	400	2	4	8.3	7.9	31.9	1.7	0.7
			3	4	13.9	10.6	40.5	2.8	2.7
			4	4	16.0	11.1	42.7	3.2	4.3
	06	600	2	4	14.9	12.9	50.4	3.0	2.4
			3	4	20.4	15.4	63.8	4.1	6.2
			4	4	22.5	16.0	67.8	4.5	9.9
			4	6	21.0	15.5	68.7	4.5	4.5
	08	800	2	4	17.9	15.0	57.4	3.6	3.5
			3	4	23.6	17.6	71.4	4.7	7.2
			4	4	25.7	18.1	74.5	5.2	10.4
			4	6	24.3	17.6	74.7	4.9	5.2
	10	1000	2	4	27.5	22.5	84.4	5.5	9.5
			3	4	34.7	26.1	100.6	7.0	7.5
			4	4	38.9	27.1	107.6	7.8	8.0
			4	9	24.2	24.2	116.1	7.7	8.0
	12	1200	2	4	35.6	29.1	102.2	7.1	10.7
			3	5	45.2	33.7	124.1	9.1	11.7
			4	6	50.7	34.4	134.8	10.1	11.8
3			6	52.6	36.4	128.0	8.5	6.9	
4			9	54.2	38.3	144.0	9.7	11.8	
FCHC cabinet (bottom return/front discharge)	02	200	2	4	5.0	4.6	20.9	1.0	0.2
			3	4	8.5	6.7	27.1	1.7	1.0
			4	4	10.3	7.3	28.1	2.1	1.8
	03	300	2	4	5.5	5.1	24.7	1.1	0.3
			3	4	10.6	8.3	32.5	2.1	1.4
			4	4	12.6	9.1	34.5	2.5	2.5
	04	400	2	4	8.0	7.6	30.9	1.6	0.7
			3	4	13.4	10.2	39.2	2.7	2.6
			4	4	15.4	10.7	41.2	3.1	4.2
	06	600	2	4	14.3	12.4	48.9	2.9	2.3
			3	4	19.7	14.9	61.6	4.0	6.0
			4	4	21.7	15.4	65.2	4.4	9.5
			4	6	21.0	15.5	68.7	4.5	4.5
	08	800	2	4	16.5	13.6	52.3	3.3	3.7
			3	4	21.5	15.8	64.2	4.3	8.8
			4	4	23.1	16.1	66.3	4.6	13.5
			4	6	24.3	17.6	74.7	4.9	5.4
	10	1000	2	4	25.0	20.0	75.1	5.0	6.0
			3	4	30.8	22.8	88.4	6.1	4.0
			4	4	34.0	23.4	92.8	6.8	3.7
			4	9	22.6	15.1	112.1	4.1	2.6
	12	1200	2	4	32.0	25.5	89.8	6.4	13.2
			3	4	39.5	28.9	107.2	7.9	19.6
			4	4	43.7	29.2	114.6	8.7	33.9
3			6	52.7	37.3	144.1	10.5	14.0	
4			9	50.8	34.6	142.2	9.7	13.1	

1. 115/1/60 PSC motor at high speed
 2. FCHH (without plenum) at 0.05" ESP
 3. Free Discharge

Four-Pipe Systems - Hot Water Preheat or Reheat (Standard or High Capacity)

All performance measured on high speed tap, 115 V, at 0.05" ESP for hideaway fan coils.

Cooling performance is based on 80/67°F (27/19°C) entering air temperature, 45°F (7°C) entering chilled water temperature with a 10°F (5.5°C) temperature rise.

Heating performance is based on 70°F (21°C) entering air temperature, 180°F (82°C) entering hot water temperature with a 30°F (17°C) temperature drop.

For other conditions and/or unit configurations, refer to DaikinTools selection program or talk to your local Daikin representative.

Table 3: Cooling and Heating Performance – Four-Pipe Systems, Hot Water Heat

Unit Model	Unit Size	Nominal Air Flow SCFM	Number of Primary Rows	Cooling Performance				Heating Performance					
				Total, MBH	Sensible, MBH	Chilled Water Flow GPM	CW Pressure Drop, Ft	1-Row				2-Row	
								Standard Capacity Coil, MBH	High Capacity Coil, MBH	Hot Water Flow (Hi Cap), GPM	Hot Water Pressure Drop (Hi Cap), Ft	Capacity Coil, MBH	Pressure Drop, Ft
FCHH no plenum, free discharge fan	02	200	2	5.1	4.7	1.0	0.2	13.0	15.5	0.9	1.8	23.2	2.9
			3	8.8	6.9	1.8	0.9	8.1	12.6	0.9	1.7	22.4	2.7
			4	10.6	7.6	2.1	1.7	12.3	14.8	0.8	1.6	21.7	2.6
	03	300	2	5.5	5.1	1.1	0.3	10.4	16.7	0.9	1.9	24.5	3.1
			3	10.5	8.3	2.1	1.3	10.1	15.8	0.9	3.4	23.8	2.9
			4	12.5	9.1	2.5	2.4	9.9	15.6	0.8	1.1	23.1	2.7
	04	400	2	7.8	8.0	1.7	0.6	13.9	21.5	1.5	6.9	32.1	2.1
			3	13.9	10.6	2.8	2.2	13.6	21.0	1.3	6.4	31.1	5.3
			4	15.8	11.0	3.2	4.1	13.2	20.6	1.3	6.4	30.2	5.0
	06	600	2	14.9	12.1	3.0	2.3	20.5	30.4	2.0	15.4	45.6	12.9
			3	19.9	15.1	4.0	5.6	18.6	27.8	1.9	5.9	48.6	15.1
			4	22.9	15.3	4.3	8.8	18.1	27.3	1.8	5.7	47.6	14.3
	08	800	2	17.3	14.3	3.4	3.2	23.5	32.6	2.2	6.5	46.6	14.4
			3	23.4	17.3	4.5	7.7	21.0	31.9	2.1	6.2	45.1	3.0
			4	25.1	17.7	5.0	12.3	20.4	31.3	2.1	6.2	45.1	3.0
	10	1000	2	26.2	21.2	5.3	8.1	34.6	43.8	2.9	11.1	74.4	6.7
			3	33.1	24.7	6.6	12.0	33.7	42.9	2.9	10.7	72.1	6.3
			4	37.5	26.0	7.5	3.5	32.9	42.0	2.8	10.3	69.9	6.0
	12	1200	2	34.0	27.5	6.8	14.7	41.6	59.0	4.0	23.8	99.1	12.6
			3	43.0	31.8	8.6	23.2	40.5	57.8	3.9	22.6	96.1	12.6
			4	48.8	33.0	9.8	14.3	39.5	56.7	3.8	21.8	93.2	11.9

115/1/60 PSC motor at High speed setting
FCHH (w/o plenum) at 0.05" ESP
Free discharge

Four-Pipe Systems - Steam Preheat or Reheat

All performance measured on high speed tap, 115 V. Medium and low-speed capacities are approximately 88% and 68% respectively of the high-speed capacity.

$$Q/ITD = \frac{MBh \text{ (kW)}}{\text{Saturated steam temp} - \text{Entering air temp}}$$

To determine heating capacities at different entering steam pressure or entering air temperature, compute the new Inlet Temperature Differential (ITD) and multiply it by the Q/ITD shown. See [Table 5](#) to determine the saturated steam temperatures at various entering steam pressures.

For more accurate values, use DaikinTools selection program available from your Daikin representative.

Table 4: Steam Coil Performance with Free-Discharge Motor

Unit Size	Steam Coil Size	Heating Capacity MBH (kW)		Q / ITD @ 2 PSIG
		2 PSIG (115 kPa)	5 PSIG (136 kPa)	MBH / °F
02	Standard Capacity	15.1	16.2	0.0952
03	Standard Capacity	16.4	17.6	0.1034
04	Standard Capacity	22.0	23.6	0.1386
06	Standard Capacity	27.9	34.7	0.1756
08	Standard Capacity	29.1	38.4	0.1827
10	Standard Capacity	32.1	44.2	0.2019
12	Standard Capacity	41.5	59.5	0.2610

Table 5: Steam Properties

Steam Pressure PSIG (kPa)	2 (13)	3 (20)	4 (27)	5 (34)
Sat. Steam Temp. °F (°C)	219 (104)	222 (106)	224 (107)	227 (108)
Latent Heat Btu/Lb (kJ/kg)	966 (2245)	964 (2242)	962 (2239)	961 (2233)

Performance Cooling and Heating – 2- and 4- Pipe

Air volumes shown in the table are measured at the motor speeds indicated with 115v/60/1 electrical power, with a 1" throwaway filter installed, and with a stamped discharge grille on a horizontal cabinet unit or a discharge duct collar on a hideaway unit at approximately 0.05 inch of pressure drop.

For other conditions and/or unit configurations, refer to DaikinTools selection program or talk to your local Daikin representative.

Table 6: Approximate Air Volume for Units with ECM Motors for 3-Row Coils and External Static Pressure up to 0.2"

Size	Horizontal		
	High	Medium	Low
02	295	228	160
03	355	260	174
04	477	346	231
06	714	527	353
08	839	634	431
10	1112	830	557
12	1401	1042	690

Air Volume Capacity Data

Air volumes shown in the table are measured with a dry coil at the motor speeds indicated with 115v/60/1 electrical power, with a 1" throwaway filter installed, and with a rear return/front discharge cabinet unit configuration.

For other unit configurations, use our DaikinTools selection program available from your local Daikin representative.

Table 7: Air Volume at Various Fan Speeds PSC Motors, SCFM

Unit model	Unit size	Number of primary rows	High Speed CFM at External Static						CFM at 0.0" ESP and Fan Speed			
			0.00"	0.05"	0.10"	0.15"	0.20"	0.25"	0.30"	High	Med	Low
FCHH no plenum, free discharge fan	02	2	364	337	303	271	229	170	111	364	301	239
		3	343	318	286	256	216	160	105	343	284	225
		4	321	298	268	240	202	150	98	321	266	211
	03	2	435	418	403	385	366	337	297	435	285	197
		3	410	394	380	363	345	318	280	410	269	186
		4	384	369	356	340	323	298	262	384	252	174
	04	2	510	472	432	388	338	264	180	510	401	280
		3	481	445	407	366	319	249	170	481	378	264
		4	451	417	381	343	299	233	159	451	354	247
	06	2	779	722	661	586	520	438	318	779	612	460
		3	734	681	623	552	490	413	300	734	577	434
		4	688	638	584	517	459	387	281	688	541	406
	08	2	844	783	765	707	639	554	439	844	643	475
		3	795	739	722	667	602	523	414	795	606	448
		4	745	692	676	625	564	490	388	745	568	420
	10	2	1226	1199	1102	992	867	725	547	1226	951	694
		3	1156	1131	1042	935	817	684	516	1156	897	655
		4	1083	1059	965	876	766	641	483	1083	841	614
	12	2	1610	1515	1410	1223	1102	942	707	1610	1249	911
		3	1518	1428	1326	1153	1039	888	666	1518	1178	859
		4	1422	1338	1244	1080	973	832	624	1422	1104	805

MCA (Minimum Circuit Ampacity), MOP (Maximum Overcurrent Protection) or MFS (Maximum Fuze Size) Calculations

The minimum circuit ampacity (MCA) is the minimum wire size required for a field-wired product. The maximum overcurrent protection (MOP), or maximum fuse size (MFS) is the maximum fuse or circuit breaker size required to properly protect the equipment.

Select a standard fuse size or HACR type circuit breaker equal to the MOP. Standard Fuse Sizes are: 15, 20, 25, 30, 35, 40, 45, 50, 60 amps. Use the next larger standard size if the MOP does not equal a standard size. See [Table 8](#) and [Table 9](#) for motor FLAs.

HACR (Heating, Air-Conditioning and Refrigeration) type circuit breakers are required in the branch circuit wiring for all fan coils with electric heat.

NOTE: MCA and MOP ratings are based on the unit and electric heat power supply having the same voltage. If the electric heat power supply is different, a separate circuit breaker may be required. Follow local codes.

$$\text{Heater Amps} = \frac{(\text{Heater kW} \times 1000)}{\text{Heater Voltage}}$$

NOTE: Use 120V heater voltage for 115V units. Use 240V heater voltage for 230V units.

$$\text{MCA} = 1.25 \times (\text{heater amps} + \text{all motor FLAs})$$

$$\text{MOP or MFS} = (2.25 \times \text{Largest Motor FLA}) + \text{Second Motor FLA} + \text{Heater Amps [If Applicable]}$$

Electric Heaters

Table 8: Electric Heat kW*

Unit Size	Unit Voltage	kW									
		1.0	1.5	2.0	2.5	3.0	4.0	5.0	6.0	7.0	8.0
02	115										
	230										
	277										
	208										
03	115										
	230										
	277										
	208										
04	115										
	230										
	277										
	208										
06	115										
	230										
	277										
	208										
08	115										
	230										
	277										
	208										
10	115										
	230										
	277										
	208										
12	115										
	230										
	277										
	208										

NOTE: *Electric heat MBh = (Heater kW) x(3.413)

Motor Electrical Data

Table 9: PSC Motor; Hideaway Plenum, Standard TA Filter; 3 Row Coil; 0.05 External Static Pressure

Motor Voltage	Motor Speed	Size 02			Size 03			Size 04			Size 06			Size 08			Size 10			Size 12		
		Amps	Watts	RPM	Amps	Watts	RPM	Amps	Watts	RPM	Amps	Watts	RPM	Amps	Watts	RPM	Amps	Watts	RPM	Amps	Watts	RPM
115	High	0.596	65.5	951	1.175	129	1190	0.747	79.2	928	1.45	147	1080	1.48	150	1072	2.53	263	1119	2.965	310.7	1068
	Medium	0.49	52.6	856	0.726	77.4	851	0.602	62.25	785	1.05	103.1	888	1.13	111	799	1.89	185	997	2.218	222.1	840
	Low	0.381	39.5	780	0.49	50.2	633	0.450	43.95	640	0.87	82	734	0.91	83	674	1.63	154	856	1.833	172.9	660
230	High	0.3	66	908	0.548	123.4	1152	0.372	86.2	909	0.657	150.6	1096	0.69	158	1085	1.19	269	1128	1.306	297.7	1105
	Medium	0.247	56.5	825	0.323	74	830	0.309	70.8	750	0.449	101.5	950	0.5	108	887	0.814	180.1	1024	0.86	195	969
	Low	0.2	46	704	0.211	46.2	628	0.251	55.9	628	0.358	76.5	777	0.38	77	720	0.663	142	840	0.69	154	844
277	High	0.303	65.1	988	0.431	110.1	1121	0.348	82.3	885	0.513	142.4	1091	0.54	151	1082	0.936	258	1124	0.997	280	1112
	Medium	0.228	57.2	866	0.24	65.5	838	0.259	67.6	762	0.371	101.6	945	0.39	106	877	0.66	178.5	1014	0.713	199	970
	Low	0.177	47.3	743	0.152	42.2	651	0.196	53.6	650	0.302	81.9	796	0.31	82	737	0.562	150	891	0.625	166	784

Table 10: ECM Motor; Hideaway Plenum, Standard TA Filter; 3 Row Coil; 0.30 External Static Pressure

Motor Voltage	Motor Speed	Size 02			Size 03			Size 04			Size 06			Size 08			Size 10			Size 12		
		Amps	Watts	RPM	Amps	Watts	RPM	Amps	Watts	RPM	Amps	Watts	RPM	Amps	Watts	RPM	Amps	Watts	RPM	Amps	Watts	RPM
115	High	1.20	65	1258	1.42	71.8	1294	1.64	89	1269	2.46	156	1363	2.92	196	1456	3.72	255	1407	4.54	321	1460
	Medium	0.94	46	1158	0.11	52	1240	1.14	62	1155	1.74	99	1220	2.24	152	1323	2.66	176	1294	3.12	208	1331
	Low	0.70	35	1099	0.86	38	1086	0.90	47	1106	1.14	67	1145	1.80	119	1263	2.00	126	1159	2.40	157	1260
230	High	0.60	65	1258	0.71	71.8	1294	0.82	89	1269	1.23	156	1363	1.46	196	1456	1.86	255	1407	2.27	321	1460
	Medium	0.47	46	1158	0.55	52	1240	0.57	62	1155	0.87	99	1220	1.12	152	1323	1.33	176	1294	1.56	208	1331
	Low	0.35	35	1099	0.43	38	1086	0.45	47	1106	0.58	67	1145	0.90	119	1263	1.00	126	1159	1.20	157	1260
277	High	0.50	65	1258	0.59	71.8	1294	0.68	89	1269	1.02	156	1363	1.21	196	1456	1.54	255	1407	1.88	321	1460
	Medium	0.39	46	1158	0.46	52	1240	0.47	62	1155	0.72	99	1220	0.93	152	1323	1.10	176	1294	1.30	208	1331
	Low	0.29	35	1099	0.36	38	1086	0.37	47	1106	0.48	67	1145	0.75	119	1263	0.83	126	1159	1.00	157	1260

Unit Data

Table 11: Physical Data: Coils, Fans, Motors and Filters

	Size 02	Size 03	Size 04	Size 06	Size 08	Size 10	Size 12
Primary Coil Data							
Face Area, ft ² (cm ²)	1.08 (1004)	1.08 (1004)	1.43(1323)	2.11(1962)	2.46(2281)	3.14(2917)	3.83(3559)
Fins/inch (cm)	12 (4.7)	12 (4.7)	12 (4.7)	12 (4.7)	12 (4.7)	12 (4.7)	12 (4.7)
Connection Size	1/2" Nominal Copper (5/8" OD)						
Coil Dimensions							
2-Row L x D x H, in (cm)	17.3 x 1.7 x 9 (43.9 x 4.4 x 22.9)	17.3 x 1.7 x 9 (43.9 x 4.4 x 22.9)	22.8 x 1.7 x 9 (57.9 x 4.4 x 22.9)	33.8 x 1.7 x 9 (85.9 x 4.4 x 22.9)	39.3 x 1.7 x 9 (99.8 x 4.4 x 22.9)	50.2 x 1.7 x 9 (127.6 x 4.4 x 22.9)	61.3 x 1.7 x 9 (155.7 x 4.4 x 22.9)
3-Row L x D x H, in (cm)	17.3 x 2.6 x 9 (43.9 x 6.6 x 22.9)	17.3 x 2.6 x 9 (43.9 x 6.6 x 22.9)	22.8 x 2.6 x 9 (57.9 x 6.6 x 22.9)	33.8 x 2.6 x 9 (85.9 x 6.6 x 22.9)	39.3 x 2.6 x 9 (99.8 x 6.6 x 22.9)	50.2 x 2.6 x 9 (127.6 x 6.6 x 22.9)	61.3 x 2.6 x 9 (155.7 x 6.6 x 22.9)
4-Row L x D x H, in (cm)	17.3 x 1.7 x 9 (43.9 x 8.8 x 22.9)	17.3 x 3.5 x 9 (43.9 x 8.8 x 22.9)	22.8 x 3.5 x 9 (57.9 x 8.8 x 22.9)	33.8 x 3.5 x 9 (85.9 x 8.8 x 22.9)	39.3 x 3.5 x 9 (99.8 x 8.8 x 22.9)	50.2 x 3.5 x 9 (127.6 x 8.8 x 22.9)	61.3 x 3.5 x 9 (155.7 x 8.8 x 22.9)
Coil Volume, Gal (Liters)							
2-Row	0.19 (0.7)	0.19 (0.7)	0.24(0.9)	0.32(1.2)	0.37(1.4)	0.46(1.7)	0.55(2.1)
3-Row	0.26 (1.0)	0.26 (1.0)	0.32(1.2)	0.45(1.7)	0.52(2.0)	0.64(2.4)	0.77(2.9)
4-Row	0.34 (1.3)	0.34 (1.3)	0.43(1.6)	0.61(2.3)	0.70(2.6)	0.87(3.3)	1.05(4.0)
Secondary Coil Data: 1-Row Standard Capacity, Hot Water or Steam							
Face Area, ft ² (cm ²)	0.61(567)	0.61(567)	0.84(780.1)	1.3(1208)	1.5(1421)	1.99(1845)	2.44(2267)
Fins/inch (cm)	12 (4.7)	12 (4.7)	12 (4.7)	12 (4.7)	12 (4.7)	12 (4.7)	12 (4.7)
L x D x H, in (cm)	14.7 x .86 x 6 (37.3 x 2.2 x 15.2)	14.7 x .86 x 6 (37.3 x 2.2 x 15.2)	20.2 x .86 x 6 (51.3 x 2.2 x 22.9)	31.2 x .86 x 6 (79.2 x 2.2 x 22.9)	36.7 x .86 x 6 (93.2 x 2.2 x 22.9)	47.7 x .86 x 6 (121.1 x 2.2 x 22.9)	58.7 x .86 x 6 (149.0 x 2.2 x 22.9)
Connection Size	1/2" Nominal Copper (5/8" OD)						
Connection Size Volume, Gal (Liters)	0.06 (0.23)	0.06 (0.23)	0.08 (0.30)	0.11 (0.42)	0.12 (0.45)	0.15 (0.57)	0.18 (0.70)
Secondary Coil Data: 2-Row High Capacity, Hot Water							
Face Area, ft ² (cm ²)	0.82 (762)	0.82 (762)	1.26 (1171)	1.73 (1607)	2.04 (1895)	2.65 (2460)	3.26 (3029)
Fins/inch (cm)	155.7 (1004.5)	155.7 (1004.5)	205.2 (1324)	304.2 (1963)	353.7 (2282)	452.7 (2921)	551.7 (3559)
L x D x H, in (cm)	17.3 x 1.73 x 9 (43.9 x 4.4 x 22.9)	17.3 x 1.73 x 9 (43.9 x 4.4 x 22.9)	22.8 x 1.73 x 9 (58.0 x 4.4 x 22.9)	33.8 x 1.73 x 9 (86.0 x 4.4 x 22.9)	39.3 x 1.73 x 9 (100.0 x 4.4 x 22.9)	50.3 x 1.73 x 9 (128.0 x 4.4 x 22.9)	61.3 x 1.73 x 9 (136.0 x 4.4 x 22.9)
Connection Size Volume, Gal (Liters)	0.16 (0.6)	0.16 (0.6)	0.22 (0.84)	0.28 (0.84)	0.32 (1.22)	0.40 (1.52)	0.36 (1.40)
Fan/Motor Data							
Fan Quantity	1	1	2	2	2	4	4
Motor Quantity	1	1	1	1	1	2	2
Filter Data							
1" (25.4 cm) Media	Throwaway (MERV 4), MERV 7*, MERV 13* and Aluminum Washable						
Quantity	1	1	1	1	1	2	2
Hideaway cm L x D x H, in. (.)	19.25 x 1.00 x 9.38 (48.90 x 2.54 x 23.83)	19.25 x 1.00 x 9.38 (48.90 x 2.54 x 23.83)	24.75 x 1.00 x 9.38 (62.87 x 2.54 x 23.83)	35.75 x 1.00 x 9.38 (90.81 x 2.54 x 23.83)	41.25 x 1.00 x 9.38 (104.78x2.54x23.83)	26.00 x 1.00 x 9.38 (66.04 x 2.54 x 23.83)	31.50 x 1.00 x 9.38 (80.01 x 2.54 x 23.83)
Cabinet L x D x H, in. (cm)	20.88 x 1.00 x 10.75 (53.04 x 2.54 x 27.31)	20.88 x 1.00 x 10.75 (53.04 x 2.54 x 27.31)	24.75 x 1.00 x 10.75 (62.87 x 2.54 x 27.31)	36.38 x 1.00 x 10.75 (92.41 x 2.54 x 27.31)	40.25 x 1.00 x 10.75 (102.24x2.54x27.31)	25.88 x 1.00 x 10.75 (65.74 x 2.54 x 27.31)	31.75 x 1.00 x 10.75 (80.65 x 2.54 x 27.31)

* For use with ECM only

Table 12: Dry Weights - lbs (kg)*

Unit Type	Unit Size						
	S02	S03	S04	S06	S08	S10	S12
FCHC/FCHR	108 (49)	110 (50)	124 (56)	139 (63)	151 (69)	184 (84)	196 (89)
FCHH	30 (14)	33 (15)	35 (16)	45 (20)	55 (25)	62 (28)	65 (30)

Note: *Approximate dry weights do not include plenums, valve packages, hot water coils, electric heaters or other options.

Unit Dimensions

Figure 13: Dimensions – Hideaway Fan Coil, Front Discharge – Free Return

Reheat coil shown

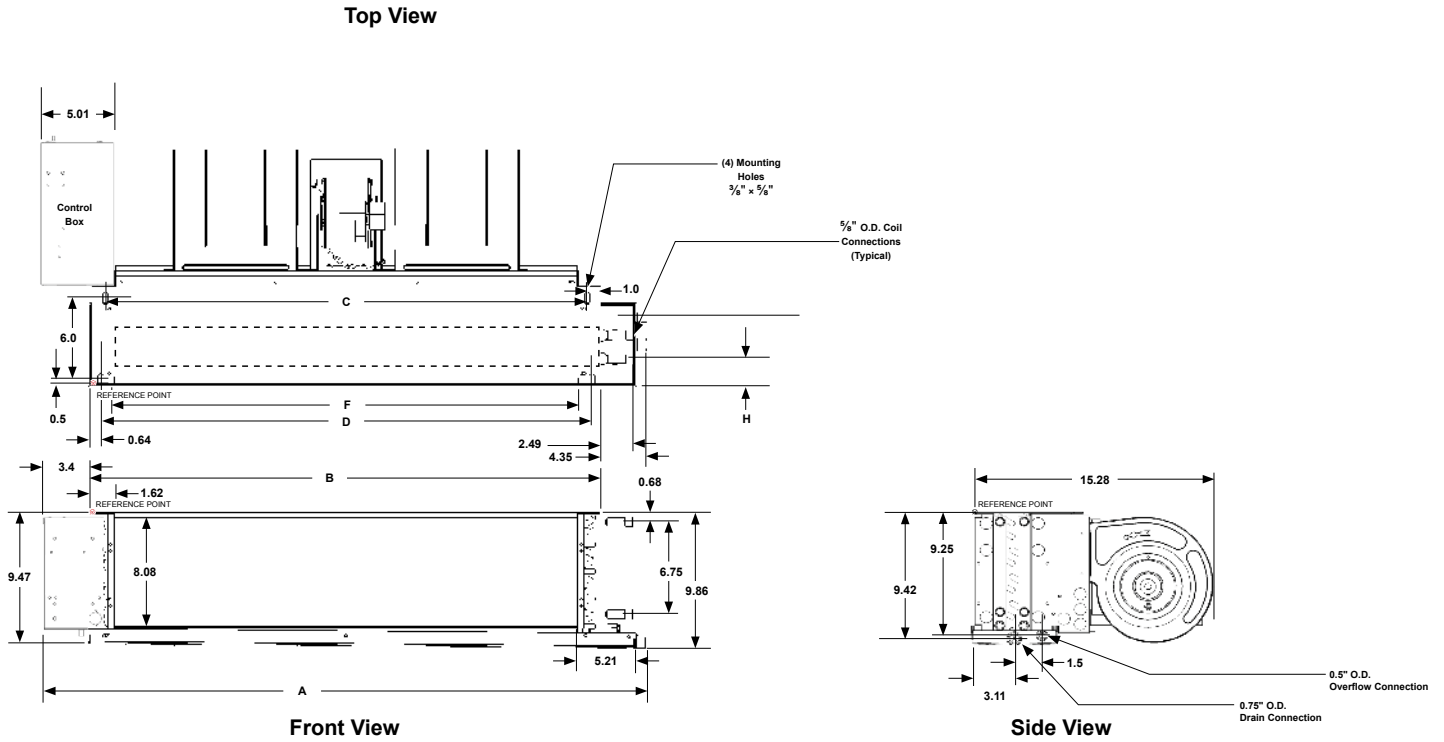

Dimension		S02	S03	S04	S06	S08	S10	S12
		inch (mm)	inch (mm)	inch (mm)	inch (mm)	inch (mm)	inch (mm)	inch (mm)
Overall Unit Width	A	28.48 (723)	28.48 (723)	33.98 (863)	44.98 (1142)	50.48 (1282)	61.48 (1562)	72.48 (1841)
Chassis Width	B	20.63 (524)	20.63 (524)	26.13 (664)	37.13 (943)	42.63 (1083)	53.63 (1362)	64.63 (1641)
Mounting Hole Distance (Rear)	C	18.64 (473)	18.64 (473)	24.14 (613)	35.14 (892)	40.64 (1032)	51.64 (1312)	62.44 (1702)
Mounting Slot Location (Front)	D	19.35 (491)	19.35 (491)	24.85 (631)	35.85 (911)	41.35 (1050)	52.35 (1330)	63.35 (1609)
Discharge Opening - Width	F	17.39 (442)	17.39 (442)	22.84 (581)	33.89 (867)	39.39 (1000)	50.39 (1280)	61.39 (1559)
Primary Coil Location	H	1.81 (46) for 2- or 3-row primary coil; 2.81 (71) for 4-row primary coil						
Secondary Coil - Standard Capacity	L	2.86 (73)						
Secondary Coil - High Capacity		0.86 (22)						
Secondary Coil - Standard Capacity	K	5.0 (127)						
Secondary Coil - High Capacity		7.0 (178)						

Figure 14: Dimensions – Hideaway Fan Coil with Plenum, Front Discharge – Rear Return

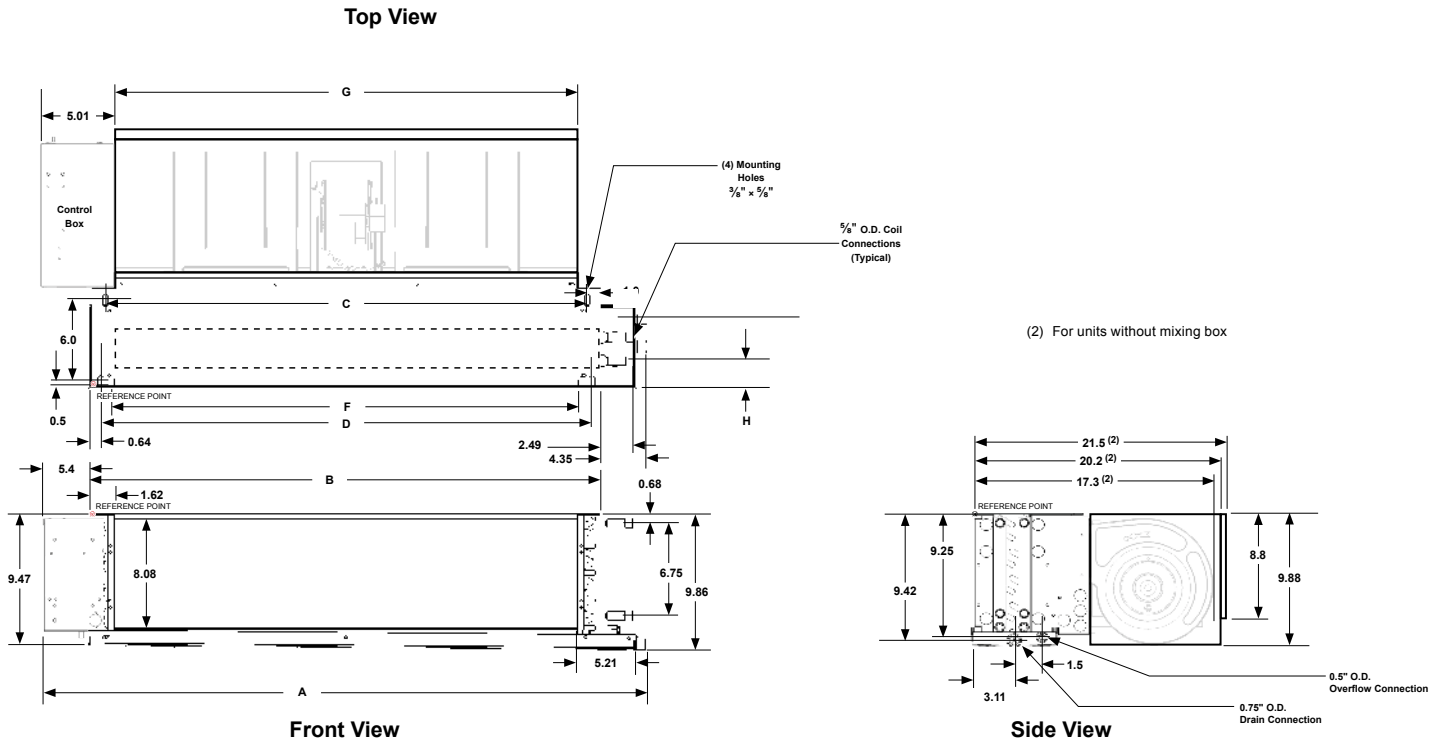

Dimension		S02	S03	S04	S06	S08	S10	S12
		inch (mm)	inch (mm)	inch (mm)	inch (mm)	inch (mm)	inch (mm)	inch (mm)
Overall Unit Width	A	30.48 (771)	30.48 (771)	35.98 (944)	46.98 (1193)	52.48 (1333)	63.48 (1612)	74.48 (1892)
Chassis Width	B	20.63 (524)	20.63 (524)	26.13 (664)	37.13 (943)	42.63 (1083)	53.63 (1362)	64.63 (1641)
Mounting Hole Distance (Rear)	C	18.64 (473)	18.64 (473)	24.14 (613)	35.14 (892)	40.64 (1032)	51.64 (1312)	62.44 (1702)
Mounting Slot Location (Front)	D	19.35 (491)	19.35 (491)	24.85 (631)	35.85 (911)	41.35 (1050)	52.35 (1330)	63.35 (1609)
Discharge Opening - Width	F	17.39 (442)	17.39 (442)	22.84 (581)	33.89 (867)	39.39 (1000)	50.39 (1280)	61.39 (1559)
Plenum/Return Air Opening - Width	G	21.5 (546)	21.5 (546)	27.0 (686)	38.0 (965)	43.5 (1105)	54.5 (1384)	65.5 (1664)
Primary Coil Location	H	1.81 (46) for 2- or 3-row primary coil; 2.81 (71) for 4-row primary coil						
Secondary Coil - Standard Capacity	L	2.86 (73)						
Secondary Coil - High Capacity		0.86 (22)						
Secondary Coil - Standard Capacity	K	5.0 (127)						
Secondary Coil - High Capacity		7.0 (178)						

Figure 15: Dimensions – Hideaway Fan Coil with Plenum, Front Discharge – Bottom Return

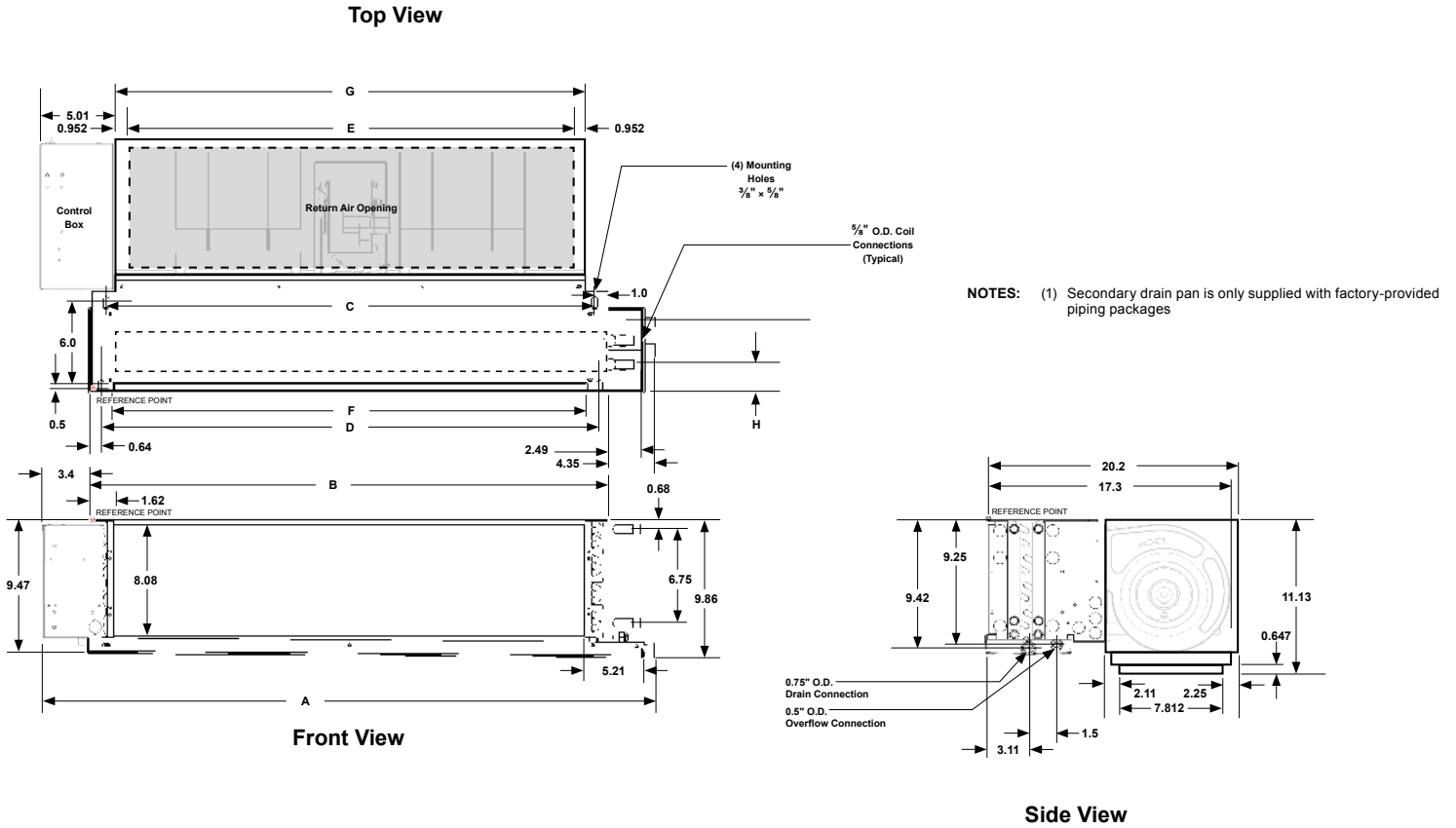

Dimension		S02	S03	S04	S06	S08	S10	S12
		inch (mm)	inch (mm)	inch (mm)	inch (mm)	inch (mm)	inch (mm)	inch (mm)
Overall Unit Width	A	30.48 (771)	30.48 (771)	35.98 (944)	46.98 (1193)	52.48 (1333)	63.48 (1612)	74.48 (1892)
Chassis Width	B	20.63 (524)	20.63 (524)	26.13 (664)	37.13 (943)	42.63 (1083)	53.63 (1362)	64.63 (1641)
Mounting Hole Distance (Rear)	C	18.64 (473)	18.64 (473)	24.14 (613)	35.14 (892)	40.64 (1032)	51.64 (1312)	62.44 (1702)
Mounting Slot Location (Front)	D	19.35 (491)	19.35 (491)	24.85 (631)	35.85 (911)	41.35 (1050)	52.35 (1330)	63.35 (1609)
Return Air Opening - Width	E	17.7 (450)	17.7 (450)	23.2 (589)	34.2 (869)	39.7 (1008)	50.7 (1288)	61.7 (1567)
Discharge Opening - Width	F	17.39 (442)	17.39 (442)	22.84 (581)	33.89 (867)	39.39 (1000)	50.39 (1280)	61.39 (1559)
Plenum Width	G	21.5 (546)	21.5 (546)	27.0 (686)	38.0 (965)	43.5 (1105)	54.5 (1384)	65.5 (1664)
Primary Coil Location	H	1.81 (46) for 2- or 3-row primary coil; 2.81 (71) for 4-row primary coil						
Secondary Coil - Standard Capacity	L	2.86 (73)						
Secondary Coil - High Capacity	L	0.86 (22)						
Secondary Coil - Standard Capacity	K	5.0 (127)						
Secondary Coil - High Capacity	K	7.0 (178)						

Figure 16: Dimensions – Cabinet Fan Coil, Front Discharge – Rear Return

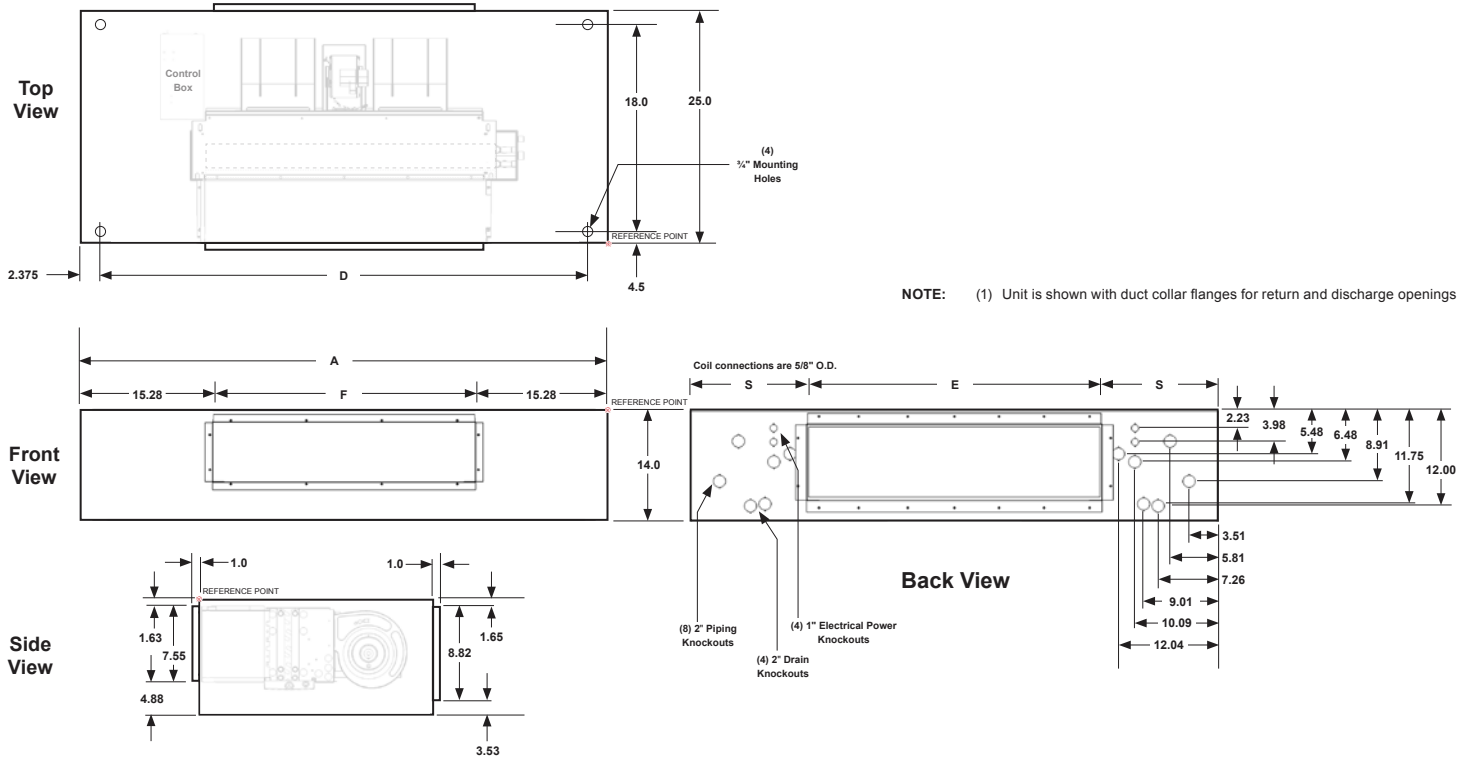

Dimension		S02	S03	S04	S06	S08	S10	S12
		inch (mm)	inch (mm)	inch (mm)	inch (mm)	inch (mm)	inch (mm)	inch (mm)
Overall Unit Width	A	47.64 (1210)	47.64 (1210)	53.14 (1350)	64.14 (1629)	69.64 (1769)	80.63 (2048)	91.64 (2328)
Mounting Hole Distance	D	40.64 (1032)	40.64 (1032)	46.14 (1172)	57.14 (1451)	62.64 (1591)	73.64 (1870)	84.64 (2150)
Return Air Opening - Width	E	19.0 (483)	19.0 (483)	22.9 (581)	34.5 (876)	38.4 (975)	50.0 (1270)	61.6 (1565)
Discharge Opening - Width	F	17.09 (434)	17.09 (434)	22.59 (574)	33.59 (853)	39.09 (993)	50.09 (1272)	61.09 (1552)
Return Air Opening Location	S	14.32 (364)	14.32 (364)	15.13 (384)	14.82 (376)	15.63 (397)	15.32 (389)	15.01 (381)

Figure 17: Dimensions – Cabinet Fan Coil, Front Discharge – Bottom Return

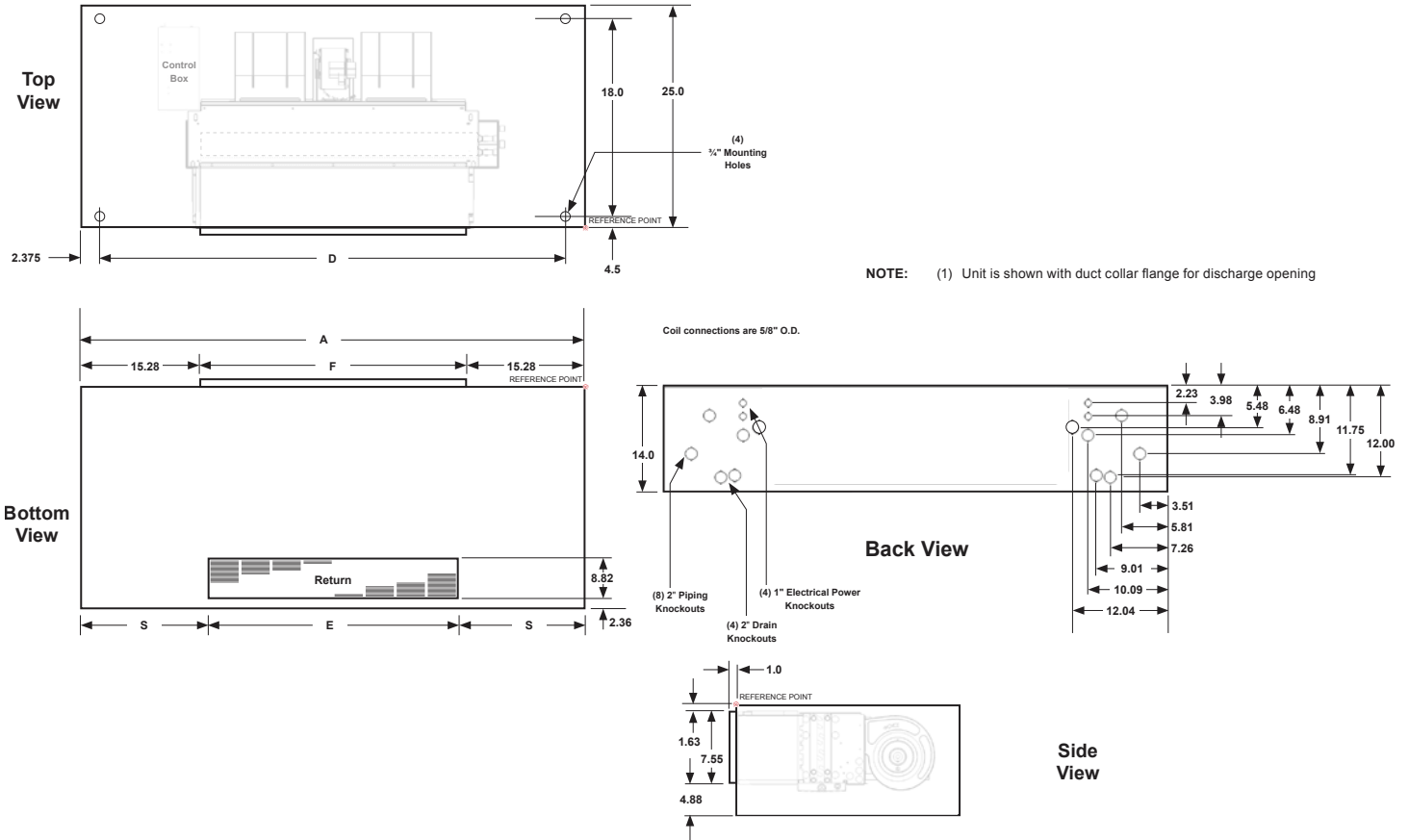

Dimension		S02	S03	S04	S06	S08	S10	S12
		inch (mm)	inch (mm)	inch (mm)	inch (mm)	inch (mm)	inch (mm)	inch (mm)
Overall Unit Width	A	47.64 (1210)	47.64 (1210)	53.14 (1350)	64.14 (1629)	69.64 (1769)	80.63 (2048)	91.64 (2328)
Mounting Hole Distance	D	40.64 (1032)	40.64 (1032)	46.14 (1172)	57.14 (1451)	62.64 (1591)	73.64 (1870)	84.64 (2150)
Return Air Opening - Width	E	16.22 (412)	16.22 (412)	21.7 (552)	32.72 (831)	38.22 (971)	49.22 (1250)	60.22 (1530)
Discharge Opening - Width	F	17.09 (434)	17.09 (434)	22.59 (574)	33.59 (853)	39.09 (993)	50.09 (1272)	61.09 (1552)
Return Air Opening Location	S	14.32 (364)	14.32 (364)	15.13 (384)	14.82 (376)	15.63 (397)	15.32 (389)	15.01 (381)

Figure 18: Dimensions – Cabinet Fan Coil, Bottom Discharge – Rear Return

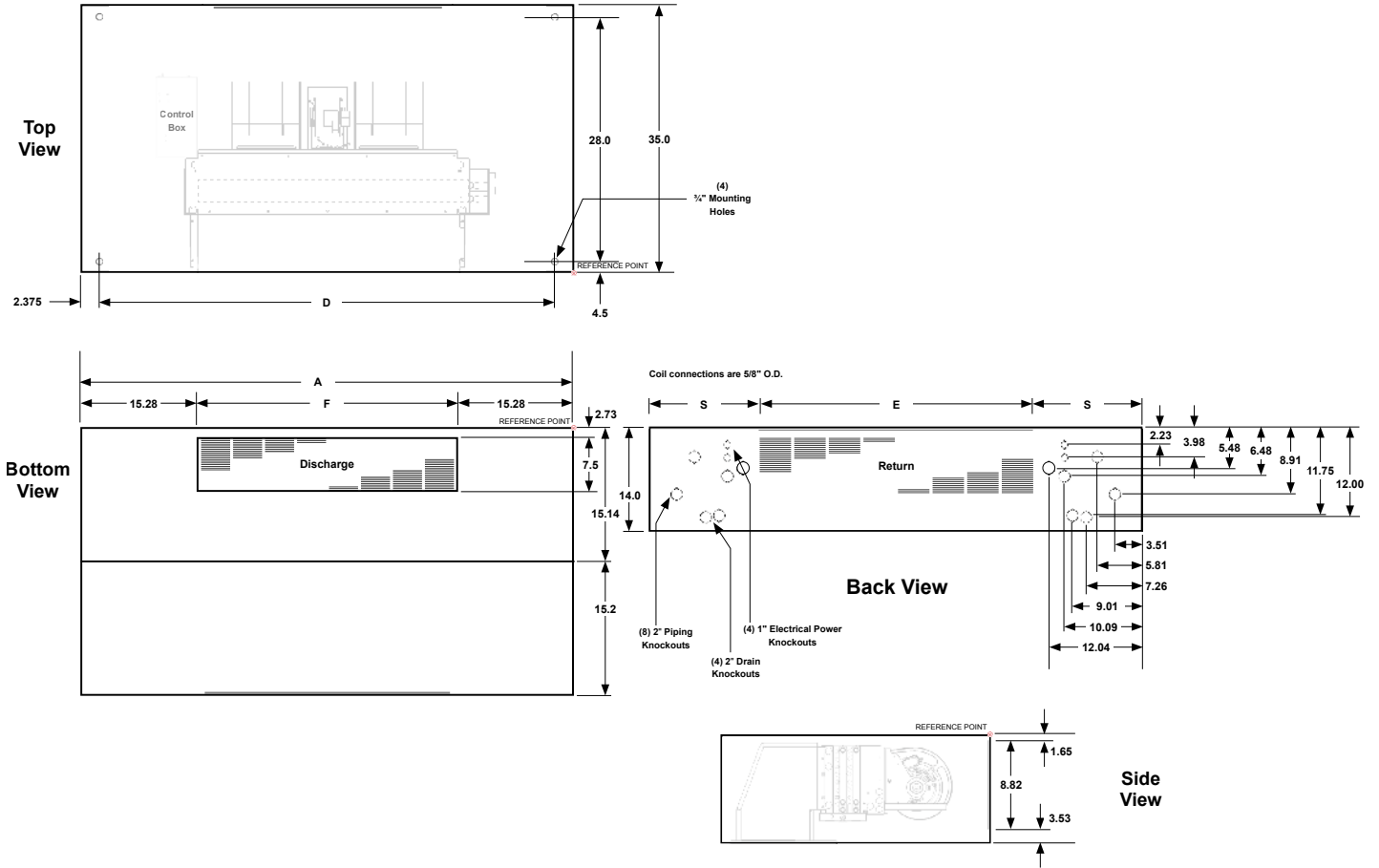

Dimension		S02	S03	S04	S06	S08	S10	S12
		inch (mm)	inch (mm)	inch (mm)	inch (mm)	inch (mm)	inch (mm)	inch (mm)
Overall Unit Width	A	47.64 (1210)	47.64 (1210)	53.14 (1350)	64.14 (1629)	69.64 (1769)	80.63 (2048)	91.64 (2328)
Mounting Hole Distance	D	40.64 (1032)	40.64 (1032)	46.14 (1172)	57.14 (1451)	62.64 (1591)	73.64 (1870)	84.64 (2150)
Return Air Opening - Width	E	16.22 (412)	16.22 (412)	21.7 (552)	32.72 (831)	38.22 (971)	49.22 (1250)	60.22 (1530)
Discharge Opening - Width	F	17.09 (434)	17.09 (434)	22.59 (574)	33.59 (853)	39.09 (993)	50.09 (1272)	61.09 (1552)
Return Air Opening Location	S	14.32 (364)	14.32 (364)	15.13 (384)	14.82 (376)	15.63 (397)	15.32 (389)	15.01 (381)

Figure 19: Dimensions – Cabinet Fan Coil, Bottom Discharge – Bottom Return

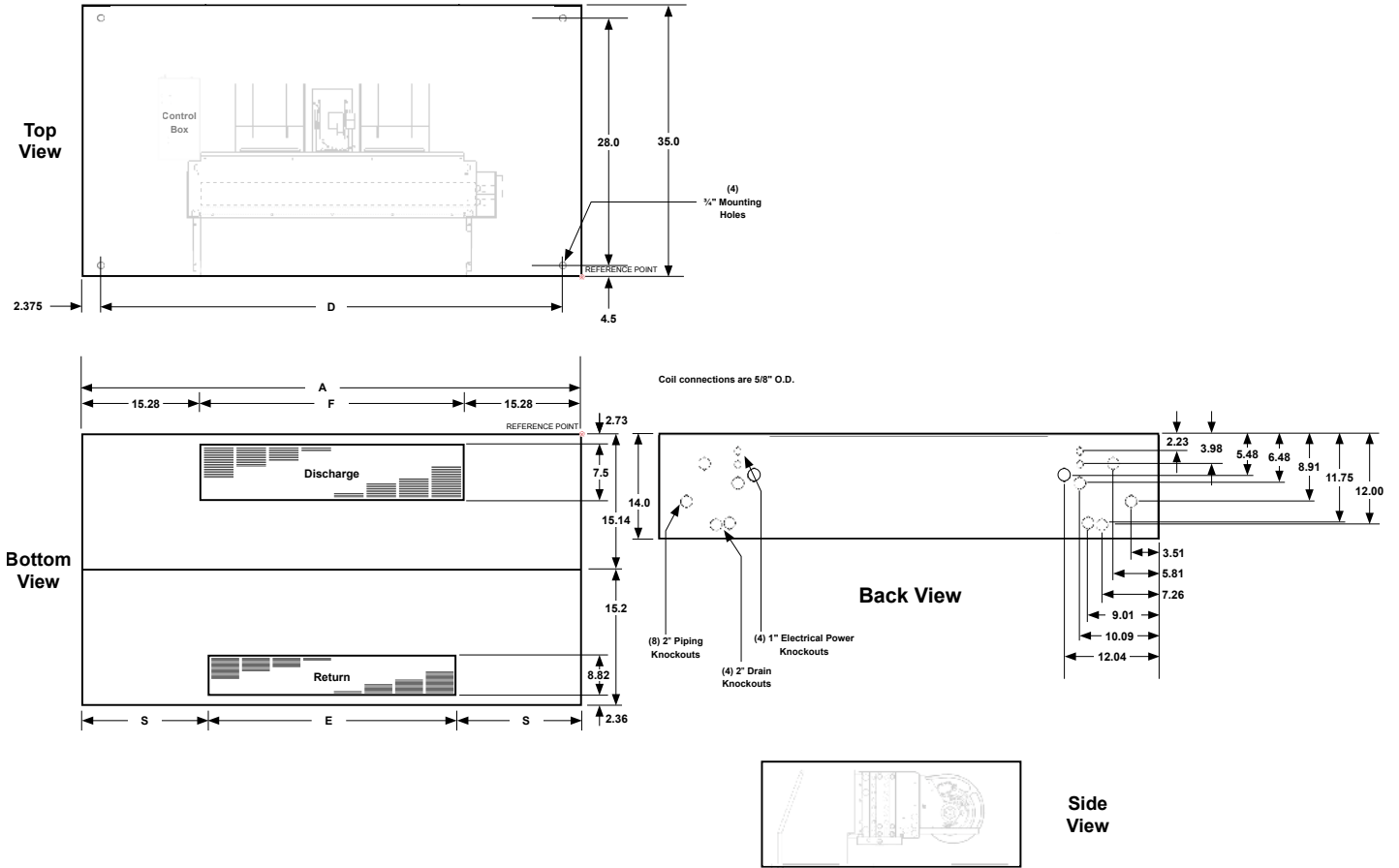

Dimension		S02	S03	S04	S06	S08	S10	S12
		inch (mm)	inch (mm)	inch (mm)	inch (mm)	inch (mm)	inch (mm)	inch (mm)
Overall Unit Width	A	47.64 (1210)	47.64 (1210)	53.14 (1350)	64.14 (1629)	69.64 (1769)	80.63 (2048)	91.64 (2328)
Mounting Hole Distance	D	40.64 (1032)	40.64 (1032)	46.14 (1172)	57.14 (1451)	62.64 (1591)	73.64 (1870)	84.64 (2150)
Return Air Opening - Width	E	16.22 (412)	16.22 (412)	21.7 (552)	32.72 (831)	38.22 (971)	49.22 (1250)	60.22 (1530)
Discharge Opening - Width	F	17.09 (434)	17.09 (434)	22.59 (574)	33.59 (853)	39.09 (993)	50.09 (1272)	61.09 (1552)
Return Air Opening Location	S	14.32 (364)	14.32 (364)	15.13 (384)	14.82 (376)	15.63 (397)	15.32 (389)	15.01 (381)

Figure 20: Dimensions – Recessed Cabinet Fan Coil with Ceiling Plate

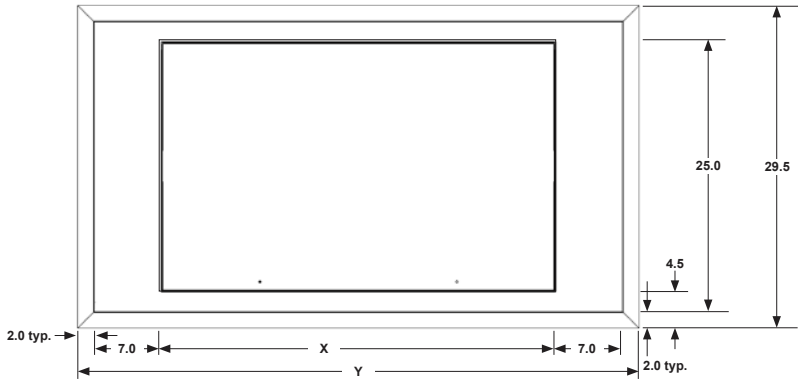

Bottom View



Side View

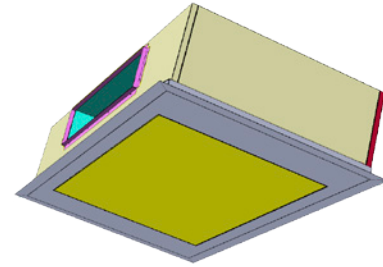

- NOTES: (1) See sheet #1 for unit dimensions
 (2) For installations with height restrictions below 14", use the fixed trim flange accessory

Unit Size	02-03	04	06	08	10	12
X	33.63	39.13	50.13	55.63	66.63	77.63
Y	51.64	57.14	68.14	74.64	84.64	95.64

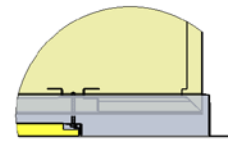

Detail A

Plate to cabinet connection for fully recessed units

Figure 21: Dimensions – Trim Flange Mount

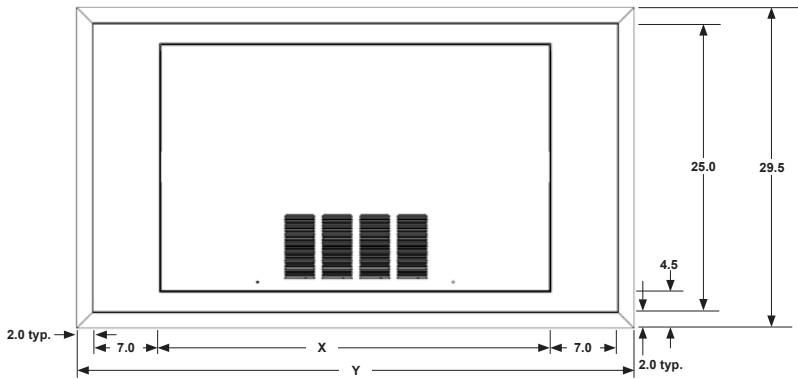

Bottom View



Side View

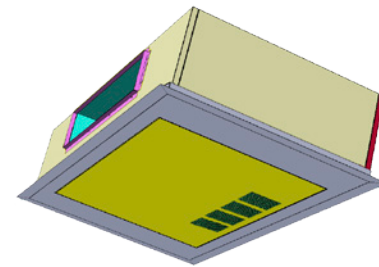

- NOTES: (1) See sheet #1 for unit dimensions
 (2) For installations with height restrictions below 14", use the fixed trim flange accessory

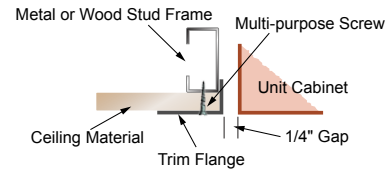

Trim Flange Securing Detail

PART 1: GENERAL

1.01 SECTION INCLUDES

- A. Horizontal Fan Coil

1.02 REFERENCES

- A. Load Ratings and Fatigue Life for Ball Bearings.
- B. Standards Handbook.
- C. Laboratory Methods of Testing Fans for Rating Purposes.
- D. Test Code for Sound Rating Air Moving Devices.
- E. Test Methods for Louver, Dampers, and Shutters.
- F. Room Fan Coil Unit.
- G. Standard Practice for Operating Salt Spray Apparatus.
- H. Motors and Generators.
- I. National Electrical Code.
- J. HVAC Duct Construction Standards - Metal and Flexible
- K. Test for Surface Burning Characteristics of Building Materials.
- L. Test Performance of Air Filter Units.
- M. Standard for Heating and Cooling Equipment.
- N. Test for Flammability of Plastic Materials for Parts in Devices and Appliances.

1.03 SUBMITTALS

- A. Shop Drawings: Indicate assembly, unit dimensions, weight loading, required clearances, construction details, field connection details, and electrical characteristics and connection requirements.
- B. Product Data
 - 1. Provide literature that indicates dimensions, weights, capacities, ratings, fan performance, gauges and finishes of materials, and electrical characteristics and connection requirements.

1.04 OPERATION AND MAINTENANCE DATA

- A. Maintenance Data: Include instructions for lubrication and filter replacement.

1.05 QUALIFICATIONS

- A. Manufacturer: Company specializing in manufacturing Air Handler products specified in this section must show a minimum five years documented experience and complete catalog data on total product.

1.06 DELIVERY, STORAGE, AND HANDLING

- A. Deliver, store, protect and handle products to site.
- B. Accept products on site wrapped in protective cardboard wrap. Inspect for damage.
- C. Store in a clean dry place and protect from weather and construction traffic. Handle carefully to avoid damage.

1.07 ENVIRONMENTAL REQUIREMENTS

- A. Do not operate units for any purpose, temporary or permanent, until ductwork is clean, filters are in place, bearings lubricated, and fan has been test run under observation.

PART 2: PRODUCTS

2.01 ACCEPTABLE MANUFACTURERS

- A. The following manufacturers are approved for use. No substitutions.
 - 1. Daikin Applied - 'ThinLine 3G' Fan Coil is the basis of design, including standard product features and all special features required per plans and specifications.
 - 2. ETI
 - 3. Greenheck

2.02 FAN COIL TYPE AND ARRANGEMENT

- A. The fan coil shall be furnished as a draw-through cooling coil with a heating coil in preheat/reheat position.

2.03 GENERAL CONSTRUCTION

- A. The units shall include a chassis, coil(s), fan deck with blower(s)/blower housing and motor(s). Steel parts exposed to moisture shall be galvanized and insulated to prevent condensation. The complete fan assembly shall be easily removable for service and maintenance. A quick-connect motor electric plug shall be provided.
- B. Hideaway
 - 1. Unit shall be supplied with return plenum complete with filter frame and filter. The plenum shall be fabricated of 18 gauge galvanized steel. The inside plenum surface shall be insulated with 1/2" matt-faced fiberglass insulation. Plenum insulation shall meet minimum K value of 0.24 (BTU-in)/(hr-ft²-F) and rated for maximum air velocity of 5000 fpm. Fiberglass insulation conforms to:
 - a. ASTM C1071 (including C665)
 - b. UL 181 for erosion
 - c. 25/50 rating for flame spread/smoke developed per ASTM E-84, UL 723 and NFPA 90A

2.04 SUPPLY FAN

- A. Supply fans shall be a DWDI forward-curved type. Fan assemblies including fan, motor and sheaves shall be dynamically balanced by the manufacturer on all three planes at all bearing supports. Manufacturer must ensure maximum fan RPM is below the first critical speed.
- B. The complete fan assembly, including motor and main drain pan shall be easily removable.
- C. Units shall be certified in accordance with the Room Fan Coil Unit certification program that is based on ARI Standard 440.
- D. An ECM blower motor shall be provided on all units. Factory motor wiring shall be set for optimum fan performance. The unit shall be shipped at one fixed setting. The ECM motor shall utilize a permanent magnet rotor, which is connected to the shaft through resilient rings to absorb high frequency torque ripple. ECM motor shall be programmed for constant CFM or constant torque.
- E. ECM blower motor shall be 3 speeds, single phase with means for proportional field adjustment of each speed.

2.05 ELECTRICAL

- A. Supply fans shall be driven by permanent split-capacitor motors that are run-tested in the assembled unit and permanently lubricated. All motors shall have integral thermal overload protection with a maximum ambient operating temperature of 104°F. Motors shall be capable of starting at 78 percent of rated voltage and operating at 90 percent of rated voltage on all speed settings. Motors can operate up to 10 percent overvoltage.
- B. Motor wires shall include a quick-disconnect motor plug.

2.06 COOLING AND HEATING

- A. Cooling Coils
 1. Cooling performance shall be as specified on the unit schedule.
 2. Water coil fins shall have full drawn collars to provide a continuous surface cover over the entire tube for maximum heat transfer. Seamless copper tubes shall be mechanically expanded into the fins to provide a continuous primary-to-secondary compression bond over the entire finned length for maximum heat transfer rates. Bare copper tubes shall not be visible between fins. Coil casing shall be constructed of galvanized steel.

3. Water coils shall be provided with headers of seamless copper tubing with intruded tube holes to permit expansion and contraction without creating undue stress or strain. Coil connections shall be copper sweat connections with connection size to be determined by manufacturer based upon the most efficient coil circuiting. Vent and drain connections shall be furnished on the coil connection, external to the cabinet. Vent connections provided at the highest point to assure proper venting. Drain connections shall be provided at the lowest point.
4. All steel parts exposed to moisture shall be galvanized.
5. Unit shall include a noncorrosive, galvanized steel main drain pan, positively sloped in every plane and insulated with closed-cell insulation. The drain pan shall be designed to ensure no pooling of condensate water per ASHRAE 62.2.
6. Unit shall include a noncorrosive, stainless steel main drain pan, positively sloped in every plane and insulated with closed-cell insulation. The drain pan shall be designed to ensure no pooling of condensate water per ASHRAE 62.2.
7. Water coils shall not exceed an internal pressure of 500 psig.

B. Water/Steam Heating Coil

1. Heating performance shall be as specified on the unit schedule.
2. Coil fins shall have full drawn collars to provide a continuous surface cover over the entire tube for maximum heat transfer. Seamless copper tubes shall be mechanically expanded into the fins to provide a continuous primary-to-secondary compression bond over the entire finned length for maximum heat transfer rates. Bare copper tubes shall not be visible between fins.
3. Coils shall be provided with headers of seamless copper tubing with intruded tube holes to permit expansion and contraction without creating undue stress or strain. Coil connections shall be copper sweat connections with connection size to be determined by manufacturer based upon the most efficient coil circuiting. Drain connections shall be furnished on the coil connection, external to the cabinet. Drain connections shall be provided at the lowest point.
4. Water coils shall not exceed an internal pressure of 500 psig.
5. Steam coils shall not exceed an internal pressure of 150 psig.

2.07 VALVE PACKAGES

- A. Fan coil units shall be provided with factory-installed valve / piping package(s) available for the primary and secondary coils. All piping packages shall be factory assembled and tested at 400 psig (2760 kPa) and re-tested for leak when factory soldered to the coil(s) at 300 psig (2069 kPa) Maximum Working Pressure of the piping package shall be 300 psig (2069 kPa).
- B. The valve package shall be designed so that any condensation is directed into the secondary drain pan. With the secondary drain pan provided, insulation of the piping package is not required.
- C. The valve package shall be provided with:
 1. Interconnecting copper piping and shut-off ball valves.
 2. Connecting supply and return lines to the unit. Four-pipe packages shall include a venting valve for the preheat or reheat coil.
 3. A manual circuit setter in the supply water pipe. The circuit setter acts as both a flow-setting device and a shut-off valve. It allows water flow through the fan coil to be set quickly and accurately. The valve shall have a memory stop so that the correct setting can be found quickly.
 4. An automatic circuit setter. The circuit setter includes a cartridge within the valve body that is sized to allow a specific flow rate through the coil. This valve sets flow through the coil without any action required by a system piping balancer.
 5. P/T ports to measure the temperature or pressure drop across the valve. This pressure drop can be compared to factory-supplied curves that relate the pressure drop to a specific flow rate.
 6. Unions at the coil connections.
 7. A 20 mesh strainer on the supply side that is easily removed for cleaning, with a blow-off valve. The strainer shall have a pressure rating of up to 400 psig (2,758 kPa).
 8. Isolating ball valve on the supply side.
 9. Balancing flow valve (auto-fixed or manual) with isolating ball valve on the return.
 10. Control valves in the supply water pipe.
 11. Two-Way/Two-Position Valves that are fully open or fully closed in response to a line voltage (115 or 265-277 VAC) or a 24 VAC signal from the Daikin Applied thermostat or controller. Some means of relieving pump head pressure should be accounted for when two-way valves are selected. Normally open or normally closed valves are available. Both are spring-return.

12. Three-Way, Two-Position Valves that either allow full water flow through the coil or divert the flow through a bypass line. The valves respond to a line voltage (115 or 265-277 VAC) or to a 24 VAC signal from the Daikin Applied thermostat or controller. All standard three-way valves come with a fixed-balance orifice in the bypass line to compensate for flow balancing in the bypass position, eliminating the need for an additional balancing valve. Normally open or normally closed valves are available.
13. Two-Way Modulating Valves that modulate the water flow through the coil in response to a signal from the Daikin Applied thermostat or controller. All standard Daikin Applied modulating valves are three-wire floating point equal percentage valves. The modulating valves are factory mounted in the supply water pipe upstream of the coil.
14. Three-Way Modulating Valves that modulate the water flow through the coil in response to a signal from the Daikin Applied thermostat or controller. Three-way valves allow water that is directed through the coil to mix with water that is directed through the bypass line. This mixture exits through the leaving water pipe. All modulating valves are three-wire, floating-point equal percentage valves.

2.08 FILTERS

- A. Filters shall be 1" (25 mm) throwaway. They shall be concealed from sight and easily removable.

2.09 MICROTECH CONTROLS

- A. The unit control board shall be the main component of the system and shall contain the required inputs/ outputs to operate a fan coil unit.
- B. Unit controller inputs/outputs: The MicroTech controller will be microprocessor-based and have capabilities, performance, and memory sufficient to execute the various functions detailed in this specification. This document will not specify a type, a manufacturer, or a family of microcontrollers to be considered for use. However, at a minimum, the following features are deemed essential:
 1. Analog Inputs: Room or Return Temperature & Timed Override Switch, Condensate Overflow, Set point Adjust, Fan Speed Switch, Heat/Cool/ Auto Switch, Entering Water Temperature, Discharge Air Temperature.
 2. Condensate Overflow. The presence of excessive condensate in the condensate drain pan is detected by a condensate sensor, which consists of a metal terminal ring mounted just below the top of the condensate pan. The analog input dedicated to condensate sensing must be capable of detecting the conductivity of water between the ring terminal and chassis ground. The conductivity trip point is 2.5 micro-ohms.

3. Set point Adjust. The Set point Adjust range will be interpreted by the base controller as an offset to the current temperature setpoint -5 to +5 degrees F or a range of 55 to 95 degrees F (software jumper selectable and scaled accordingly in software).
 4. Heat/Cool/Auto - The Room Sensor shall incorporate a voltage signal that present different values to a single analog input which correspond to the unit operating mode functions detailed below. The room sensor is designed with specific voltage values to coincide with the software in unit control module.
 5. Fan Speed Switch - The Room Sensor shall incorporate a voltage signal that present different voltage values to a single analog input which correspond to the fan speed mode functions detailed below. The room sensor is designed with specific voltage values to coincide with the software in unit control module.
 6. Temperature Input. Sensing element in the MicroTech room temperature sensor is equivalent to NTC Thermistor – 10K ohms @ 25°C, 0.2°C interchangeability. Advanced Thermal Products – Curve Z. NOTE: The Timed (Tenant) Override switch will short out the Room sensor thermistor. Sensing range shall be 0 to 158°F with a resolution of 1°F and an accuracy of +/- 1.5°F Maximum Total Error.
 7. Binary Inputs. 2 total (Freeze Fault Detection, Occupancy Sensor)
- C. Binary Outputs: 9 total (Fan Low Speed, Fan Medium Speed, Fan High Speed, Valve Output #1, Valve Output #2, Valve Output #3, or Electric Heat Stage 1, Valve Output #4 or Electric Heat Stage 2, 2 Position Damper, Room Sensor Status LED).
 1. Fan Speed Outputs -There are three fan speed outputs on baseboard. If all three outputs are de-energized, the fan motor is off. Only a single type (low, medium, high) of speed output shall be turned on when fan operation is required.
 2. Two-Position Damper Output: Binary output may be used to open a fresh air ventilation damper. If the output is de-energized, the damper is closed. If the output is energized, the damper is open.
 3. Room Sensor Status Output: Binary output may be used to energize and de-energize an indicator located on the room sensor. See Room Sensor Status Output Annunciation Table.
 - D. Automatic Fan speed selection.
 1. When the fan mode/speed switch is in the “Auto” position and capacity is required, the fan speed is determined automatically based on the amount of error from the respective heating or cooling on setpoint. If the room temperature error exceeds 4°F (2.22°C), the fan will be “forced on” in the highest available fan speed. Once the room temperature error falls below 3°F (1.67°C), the fan will no longer be “forced on” in the highest available fan speed. If the “Highest Speed Force On” is not active the fan will start at low speed, and fan speed changes are determined by whether the room temperature is above or below the effective controlling on setpoint.
 - E. Valve and Electric Heat Control
 1. The controller will be factory configurable for the following valve and electric heat control configurations.
 - F. Software Jumpers
 1. Software Jumpers will be designed into the MicroTech Fan Coil controller and used to modify controller configuration to match equipment configuration. The values of the jumper’s (zero or one) shall set valve operation, fan operation, etc. Software Jumper definitions are below

- G. Intelligent Reset: (Condensate Overflow Alarm). The “Fault Retry” feature helps to minimize nuisance trips of automatic lockouts caused by low-pressure or low temperature faults. This feature automatically clears these faults the first two times they occur within a 24-hour period and triggers an automatic lockout on the 3rd fault. The retry count is reset to zero every 24 hours. The fault retry feature does not apply to a high pressure fault – which causes an immediate lockout and requires a manual reset, or condensate overflow or brownout faults – which are self-clearing.
- H. MicroTech Unit Controller Status LED: Remote LED boards will provide visual feedback.
 - 1. Room Sensor Status LED: A 5VDC signal and shall operate as follows:
- I. Warranty - The contractor shall provide one full year warranty for furnishing parts on site which becomes defective in normal operation, from the date of start-up by the manufacturer’s representative, or first beneficial use of the unit.
 - 1. Manufacturer’s warranty time periods may or may not coincide with the contractor’s time period of obligation, but where the manufacturer’s warranty contains an expiration date based upon the equipment shipping date, the contractor shall not be relieved of responsibility for covering the full time periods listed above.
 - 2. The contractor shall be responsible for all shipping expenses not included by the manufacturer, both to procure the replacement part, and to return any defective parts to the manufacturer, as they may require.
 - 3. The contractor’s replacement warranty obligation after the first year shall be limited to furnishing of replacement parts only, and shall not include repair labor costs or materials such as refrigerant, oils, dehydration, refrigerant- moisture dryers, air filters, or drive belts.
 - 4. The owner shall be responsible for providing replacement filters beyond the spares provided in the original contract, and for filter installation labor.

PART 3: EXECUTION

3.01 INSTALLATION

- A. The Thinline Fan Coil unit shall be installed per manufacturer’s Installation & Maintenance Bulletin.
 - 1. Selected field mounted kits shall be specified on the unit schedule and installed per manufacturer’s instruction.



Daikin Applied Training and Development

Now that you have made an investment in modern, efficient Daikin equipment, its care should be a high priority. For training information on all Daikin HVAC products, please visit us at www.DaikinApplied.com and click on Training, or call 540-248-9646 and ask for the Training Department.

Warranty

All Daikin equipment is sold pursuant to its standard terms and conditions of sale, including Limited Product Warranty. Consult your local Daikin Applied Representative for warranty details. To find your local Daikin Applied Representative, go to www.DaikinApplied.com.

Aftermarket Services

To find your local parts office, visit www.DaikinApplied.com or call 800-37PARTS (800-377-2787). To find your local service office, visit www.DaikinApplied.com or call 800-432-1342.

This document contains the most current product information as of this printing. For the most up-to-date product information, please go to www.DaikinApplied.com.

Products manufactured in an ISO Certified Facility.